

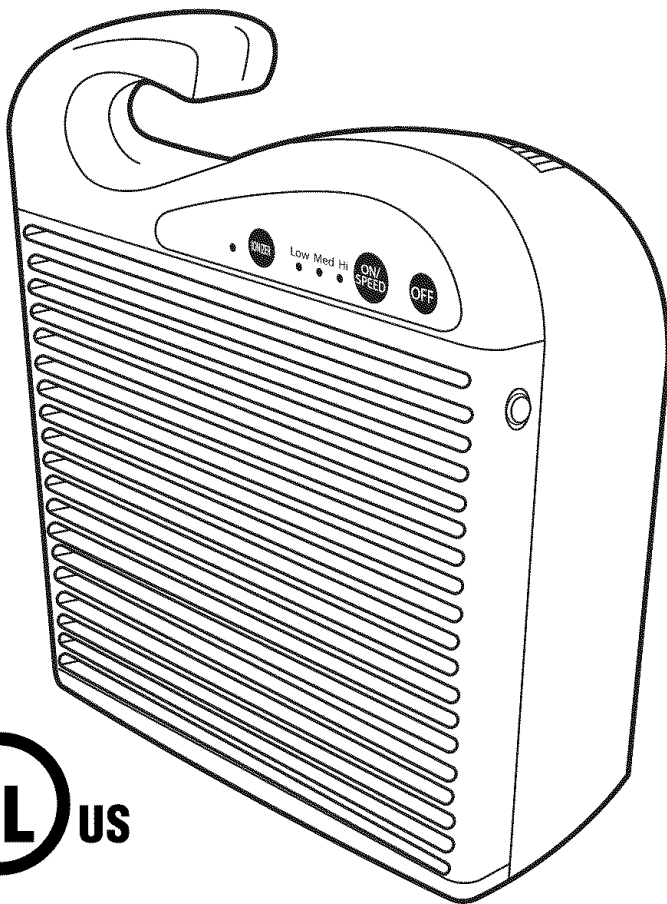

OWNER'S MANUAL FOR KENMORE AIR CLEANER MODEL 152.83244



INFO-LINE:

After reading this manual, if you have any questions or comments on your Kenmore air cleaner, call: 1-888-277-2810

- **Safety**
- **Warranty**
- **Operation**
- **Parts**

IMPORTANT SAFETY INSTRUCTIONS

Please read all instructions before using this product. Save these instructions for easy reference. When using electrical appliances, basic precautions should always be followed to reduce breakage, risk of fire, electric shock and injury to persons including the following:

- Read all instructions before operating the air cleaner.
- Place air cleaner where it is not easily knocked over by persons in the household.
- Always unplug air cleaner when not in use.
- Do not use any product with a damaged cord or plug or if product malfunctions, is dropped or damaged in any manner.
- Keep power cord away from heated surfaces.
- Do not use air cleaner outdoors.
- Never use air cleaner unless it is fully assembled.
- Do not run power cord under carpets, and do not cover with throw rugs. Arrange cord such that it will not be tripped over.
- Do not use air cleaner where combustible gases or vapors are present.
- Do not expose the air cleaner to rain, or use near water, in a bathroom, laundry area or damp location.
- To disconnect the air cleaner, first turn the speed control to OFF position and remove plug from the outlet.
- Do not allow foreign objects to enter ventilation or exhaust opening as this may cause electric shock or damage to the air cleaner. Do not block air outlets or intakes.
- Locate air cleaner near power outlet and avoid using extension cord.
- The air cleaner has a polarized plug (one blade is wider than the other). To reduce risk of shock, this plug is intended to fit in a polarized outlet only one way. If the plug does not fit fully in the outlet, reverse the plug. **DO NOT** attempt to defeat this safety feature.
- A loose fit between the plug and the AC outlet (receptacle) may cause overheating and a distortion of the plug. Contact a qualified electrician to replace loose or worn receptacles.
- Do not sit, stand or place heavy objects on the air cleaner.
- Disconnect power supply before servicing.
- **WARNING:** To reduce risk of fire or electric shock, do not use this product with any solid-state speed control device.

FULL ONE YEAR WARRANTY

If this air cleaner fails due to a defect in material or workmanship within one (1) year from the date of purchase, Sears will replace it free of charge.

This warranty DOES NOT cover the replacement of the HEPA filter which is an expendable item.

This warranty applies only while this product is in use in the United States or Canada.

This warranty gives you specific legal rights and you may also have other rights, which may vary from state to state.

Sears, Roebuck and Co., D/817WA, Hoffman Estates, IL 60179

INTRODUCTION

Congratulations on your choice of the Kenmore air cleaner. We highly recommend that you operate the air cleaner 24 hours a day, because indoor air can quickly be contaminated by activity or objects in a room and infiltration of outside air. Portable air cleaners are much more effective in rooms where all doors and windows are closed.

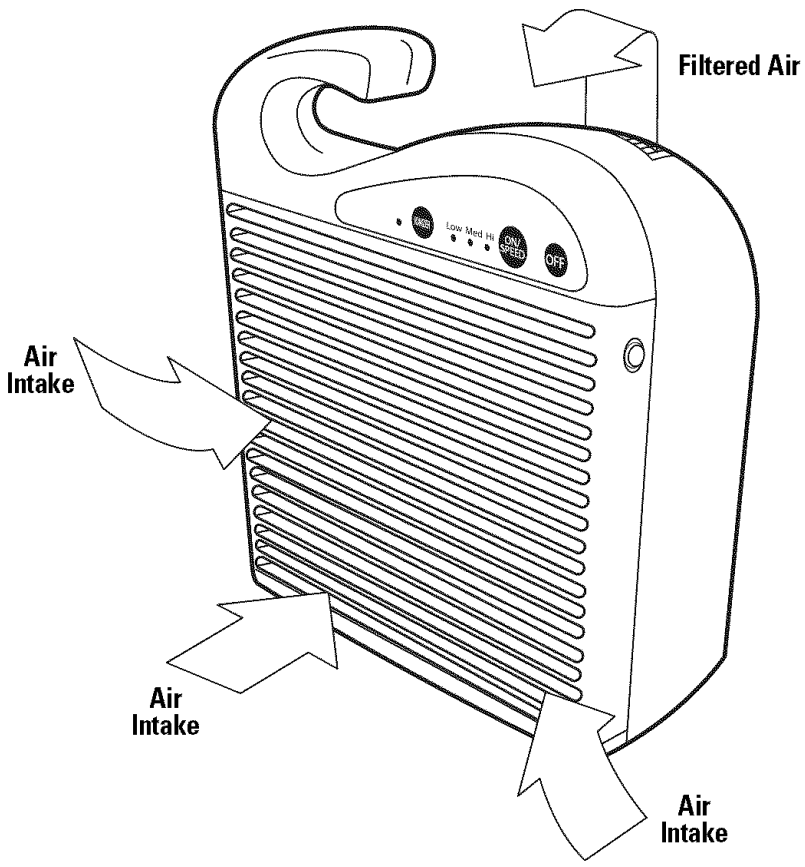

HOW IT WORKS

This air cleaner is equipped with a HEPA (High Efficiency Particulate Arrestor) filter. Room air is drawn into the air cleaner through the air intake grille and passes through the HEPA filter. The filtered air is released from the top of the unit and is dispersed upwards into the room.

The air cleaner has three operating speeds, HI, MED and LO. The indicator light is "ON" when the air cleaner is operating.

Your air cleaner has an ionizer with a red light indicating when it is turned "ON".

Use of ionizer boosts cleaning efficiency and revitalizes stale air.

Your air cleaner has a convenient carrying handle for easy portability.

SETUP

Your air cleaner was thoroughly inspected and tested at the factory prior to packaging.

Visually inspect it upon removal from its box. Remove and discard any packaging material. Return the unit if it shows any signs of damage or mishandling.

Note that there is a label on the side of the unit as a reminder of when the HEPA filter should be replaced. Using a ballpoint pen, write on the label a date six months away from the first operation date. See FILTER CHANGE SCHEDULE below.

ELECTRICAL HOOKUP

Plug the air cleaner into a polarized 120 volt AC wall outlet.

WARNING: To avoid fire or shock hazard, the air cleaner should ONLY be plugged into a polarized 120 Volt AC outlet.

OPERATION

CAUTION: Never operate the air cleaner without the filters properly installed.

Permanent motor damage could result.

Each time you operate the air cleaner, it is a good idea to run it at HI speed for fast initial cleaning, then set as desired.

- HI. Maximum Operation Fast Initial Cleaning
- MED. Daytime Operation
- LO Nighttime Use/Quieter operation
- On/Off Ionizer Operation Use for fast initial cleaning
- When the ionizer is activated it helps to further clean and freshen the air by precipitating out small airborne particles. When using ionizer, be sure to place air cleaner about one foot away from the walls. This will keep precipitated dust particles from depositing on the walls.

FILTER CHANGE SCHEDULE

HEPA Filter: The usable lifetime of the HEPA filter is 6 to 12 months depending upon the level of air contaminants in the room and the frequency of use. The HEPA filter will turn medium brown and air volume output will begin to decrease dramatically when the filter needs to be changed. Compare the color of HEPA filter to the “change filter” color chart label located near the filter frame and change the filter as necessary. You should have a spare filter available for later replacement.

FILTER REPLACEMENT

This HEPA filter is specially designed for easy replacement to ensure maximum performance. **THE HEPA FILTER IS NOT WASHABLE.**

1. Turn the air cleaner OFF and unplug the unit from the power outlet.
2. Carefully lay unit down on a flat surface with front grille facing up.
3. Using finger pressure on the two release buttons on the sides, pull front grille out and away.
4. Remove and discard the old HEPA filter.
5. Remove any protective plastic wrapping and packaging from the new HEPA filter.
6. Set new HEPA filter into the air cleaner.
7. Install the front grille by placing the bottom edge of the grille near the bottom of the air cleaner, lining up the grille tabs with the air cleaner slots.
8. Snap front grille into place by pushing down carefully near the top edges of the front grille.
9. Write the next filter change date - 6 months away - on the side label.
10. Turn the air cleaner upright and plug it into an outlet. The air cleaner is now ready for operation.

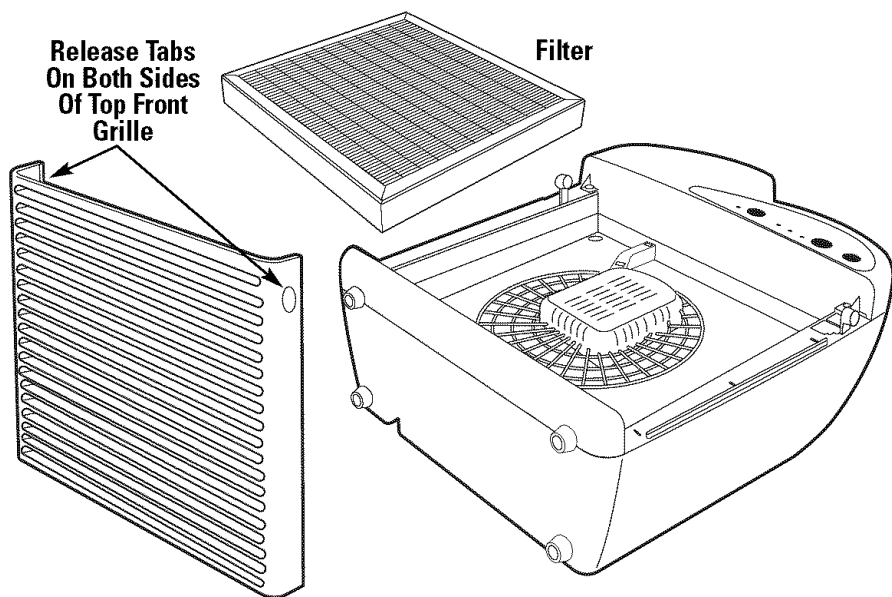

CLEANING THE UNIT

WARNING: To avoid serious injury from electric shock, the air cleaner must be turned OFF and unplugged from the power outlet prior to any cleaning operation.

1. Turn air cleaner OFF and unplug from power outlet.
2. Clean unit with moistened soft cloth only. DO NOT pour or splash water on the unit or use any abrasive type cleaner on it. Clean all external surfaces, especially the air intake grilles and air outlet.
3. **DO NOT** attempt to clean the HEPA filter; it is NOT washable and washing will damage it.
4. Reposition air cleaner, plug into power outlet and turn ON.

STORAGE

If you store your air cleaner for more than 30 days, you should:

1. Remove HEPA filter from the unit.
2. Wrap the HEPA Filter in an airtight plastic bag or plastic wrap. Be sure that the HEPA filter is totally sealed to protect it from its storage environment.
3. **DO NOT** put plastic-wrapped HEPA filter back into the air cleaner.

To restore the air cleaner to service:

1. Unwrap the HEPA Filter.
2. Install HEPA filter in the air cleaner. See "Filter Replacement" section for proper installation.

TECHNICAL SPECIFICATIONS

Model	83244
Length	15 in (38cm)
Width	6.7 in (17cm)
Height	14.4 in (36.5cm)
Weight	9.1 lb. (4.1kg)
Input Voltage	120 volts AC, 60 Hz

REPLACEMENT PARTS

Model	83244
Filter	83159

CUSTOMER ASSISTANCE LINE

If you experience a problem, please **DO NOT** attempt to repair this unit yourself. Doing so will void your warranty and could cause damage to the air cleaner or personal injury to yourself. If you have any questions concerning this appliance, please call toll free:

1-888-277-2810 / Monday - Friday — 8:30 a.m. to 5:00 p.m. EST

HOW TO ORDER REPLACEMENT PARTS

To order replacement filters or front grilles by phone, call toll free:

1-800-366-7278 / 7:00 a.m. to 7:00 p.m. — 7 days a week