

# OPERATOR'S MANUAL

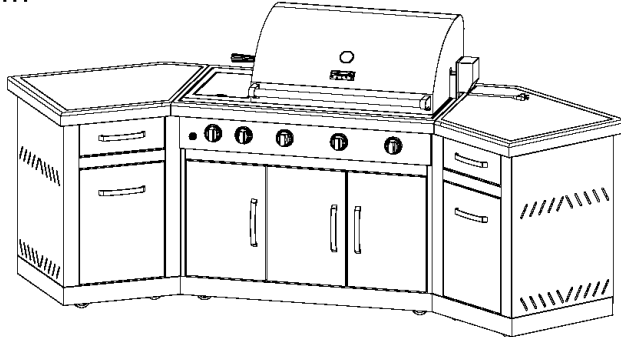

Liquid Propane Gas (LPG) Grill  
Model 119.166790  
Natural Gas (NG) Grill  
Model 119.176790  
2-Island Set (for both grills)  
Model 119.166830



- Safety
- Assembly
- Use and Care
- Cooking Guide
- Frequently Asked Questions



## Customer Support Center:

**Call us first** if you have any problem with this product. We can help you with questions about assembly and grill operation or if there are damaged or missing parts when you unpack this unit from the carton. Please call before returning to the store.

**1-800-933-0527**

8:30am-5:00pm CST, Monday through

## IMPORTANT:

- **NOTE TO ASSEMBLER/INSTALLER:**  
Leave this manual with the consumer.
- **NOTE TO CONSUMER:**  
Keep this manual for future reference.
- **RECORD YOUR SERIAL#** \_\_\_\_\_  
(see silver CSA label on main body of grill)
- **DATE OF PURCHASE:** \_\_\_\_\_
- **ATTACH YOUR SALES RECEIPT HERE:**  
\_\_\_\_\_



## WARNING



- Failure to comply with these instructions could result in a fire or explosion that could cause serious bodily injury, death or property damage.
- Whether this grill was assembled by you or someone else, you must read this entire manual before using your grill to ensure the grill is properly assembled, installed and maintained.
- **Use your grill at least 2 feet away from any wall or surface** . Use your grill at least 2 feet away from combustible objects that can melt or catch fire (such as vinyl or wood siding, fences and overhangs) or sources of ignition including pilot lights on water heaters and live electrical appliances.
- THIS GAS APPLIANCE IS DESIGNED FOR OUTDOOR USE ONLY.
- Combustion byproducts produced when using this product contain chemicals known to the State of California to cause cancer, birth defects, or other reproductive harm.

## Table of Contents

Primary Safety Warnings.....	1-3
Warranty Terms and Conditions.....	2
Pre-Assembly Instructions.....	3
Part Diagram and Lists.....	4-10
Assembly Instructions.....	11-17
LP Gas Tank Instructions.....	18-20
Natural Gas Instructions.....	21-22
Use and Care Instructions.....	23-26
Cleaning and Maintenance.....	26-27
Cooking Guide.....	28-29
Frequently Asked Questions.....	30-31
Sears Parts and Service Information .....	32

## Warranty Information

### Two-Year Full Warranty on Kenmore Elite Grill

If this grill fails due to a defect in material or workmanship within two years from the date of purchase, call 1-800-4-MY-HOME® to arrange for free repair (or replacement if repair proves impossible).

### Additional Limited Warranty on Specific Grill Parts

After the second year from date of purchase for the time periods listed below the following specific grill parts will be supplied free of charge if they fail due to defects in material or workmanship. You will pay any labor charges if you wish to have them installed.

- Stainless Steel Tube Burners – Unlimited
- Other Stainless Steel Parts – 3 years

### Warranty Restrictions

All warranty coverage excludes igniter batteries, grill paint loss, rusting or stainless steel discoloration, which are either expendable parts that can wear out from normal use in less than two years, or are conditions that can be the result of normal use, accident or improper maintenance.

All warranty coverage is void if this grill is ever used for commercial or rental purposes.

All warranty coverage applies only if this grill is used in the United States. This warranty gives you specific legal rights, and you may have other rights which vary from state to state.

**Sears, Roebuck and Co.,  
Hoffman Estates, IL 60179**



## DANGER



### IF YOU SMELL GAS:

1. **Shut off gas to the appliance.**
2. **Extinguish any open flame.**
3. **Open lid.**
4. **If odor continues, keep away from the appliance and immediately call your gas supplier or your fire department.**



## WARNING



1. **Do not store a spare LP cylinder within 10 feet (3m) of this appliance.**
2. **Do not store or use gasoline or other flammable liquids and vapors within 25 feet (8m) of this appliance.**
3. **When cooking with oil or grease, do not allow the oil or grease to get hotter than 350°F (177°C).**
4. **Do not leave oil/grease unattended.**

### Grill Installation Codes

The installation must conform with local codes or, in the absence of local codes, with either the National Fuel Gas Code, ANSI Z223.1/NFPA 54, or CAN/CGA- B149.1, Natural Gas and Propane Installation Code.

All electrical accessories (such as a rotisserie or light) must be electrically grounded in accordance with local codes, or, in the absence of local codes, with the National Electrical Code, ANSI/NFPA 70, or the Canadian Electrical Code, CSA C22.1. Keep any electrical cords and/or fuel supply hoses away from all hot surfaces.

## Pre-Assembly Instructions For Your Safety



### WARNING



Failure to comply with these instructions could result in a fire or explosion that could cause serious bodily injury, death or property damage.

Spiders and small insects can spin webs and nest in the grill burner tubes during transit and warehousing which can lead to a gas flow obstruction resulting in a fire in and around the burner tubes. This type of "FLASHBACK FIRE" can cause serious grill damage and create an unsafe operating condition for the user.

**To reduce the chance of a FLASHBACK FIRE you must clean the burner tubes as follows before initial use.** Also do this at least once a month in summer and fall or whenever spiders are active in your area, and if your grill has not been used for an extended period of time.

1. Remove the screw from the rear of each burner using a Phillips head screwdriver.
2. Carefully lift each burner up and away from the gas valve orifice.
3. Check and clean the burner tubes for insects and insect nests. A clogged tube can lead to a fire beneath the grill.
4. Refer to the figure below and perform one of these 2 cleaning methods:

- METHOD 1:** Use a bottle brush with a flexible handle and run the brush through the burner tube and inside the burner several times to remove any debris.
- METHOD 2:** Use an air hose to force air through each burner tube. The forced air should pass debris or obstruction through the burner and out the ports.

For safe operation ensure the gas valve assembly orifice is inside the burner tube before using your grill. See figure. If the orifice is not inside the burner tube, lighting the burner may cause an explosion and/or fire resulting in serious bodily injury and/or property damage.

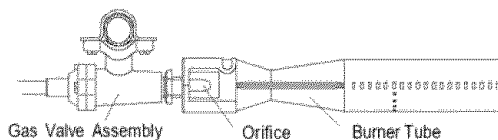

### WARNING



Liquid Propane Gas (LPG) grill models must be used with LP gas and the LP gas regulator assembly supplied. Natural Gas grill models must be used with Natural Gas only. Any attempt to convert the grill from one fuel type to another is extremely hazardous and will void the warranty.

**Never** use your gas grill in a garage, porch, shed, breezeway or any other enclosed area.

**Never** obstruct the flow of ventilation air around your gas grill cabinet.

**Never** disconnect the gas regulator assembly or any gas fitting while your grill is lit. A lit grill can ignite leaking gas and cause a fire or explosion which could result in property damage, personal injury or death.

Keep the gas regulator hose or natural gas hose away from any heated surface and dripping grease. Avoid unnecessary twisting of the hose. Visually inspect the hose prior to each use for cuts, cracks, excessive wear, or other damage. If the hose appears damaged, do not use the gas grill. Call Sears at 1-800-4-MY-HOME® (1-800-469-4663) for a Kenmore replacement gas hose assembly or natural gas hose depending on your model.

## PRE-ASSEMBLY

**Read and perform the following pre-assembly instructions:**

**Tools Required for Assembly include:**

- protective work gloves
- protective eyewear
- Phillips Head Screwdriver (included in hardware pack in Parts Box)

- You will need assistance from another person to handle the grill head and other large, heavy parts.
- Open lid of shipping carton and remove parts box and packing materials. Lay a cardboard sheet on floor and use as a work surface to protect floor and grill parts from scratches.
- Slice all four corners with a utility knife to lay open the carton. This allows you to remove the grill head and components packed inside.
- Use the Hardware and Part Diagrams to ensure all items are included and free of damage.
- Do not assemble or operate the grill if it appears damaged. If there are damaged or missing parts when you unpack the shipping box or you have questions during the assembly process, call the:

**Customer Support Center at 1-800-933-0527**  
8:30am-5:00pm CST, Monday through Friday.

# Detail Parts List for 119.166790/166830 & 119.176790/166830

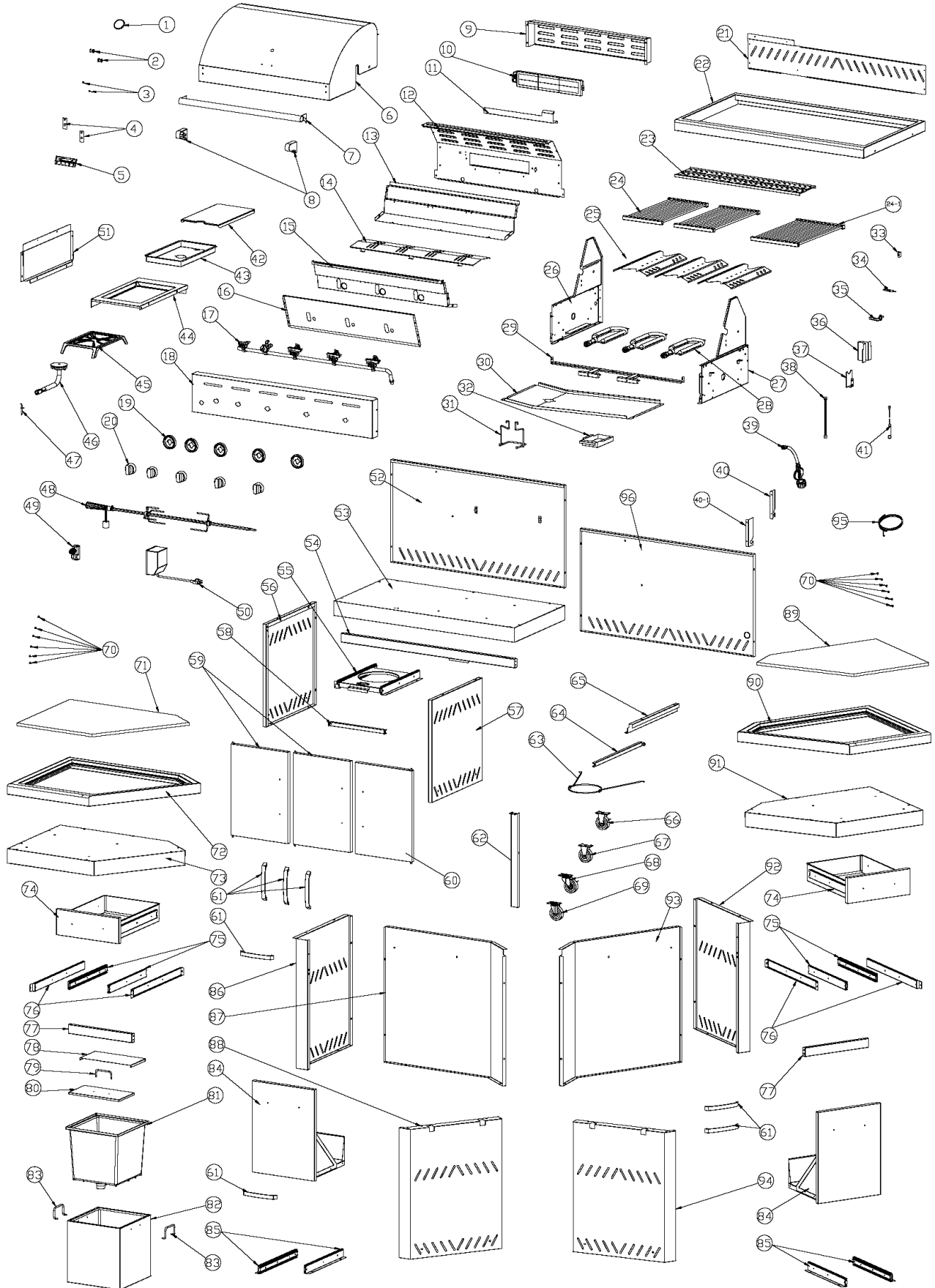

## Parts List for Models 119.166790/166830 & 119.176790/166830

KEY	DESCRIPTION	PART#	QTY
1	Thermometer	SE0076	1
2	Hood Bolt	SB0001-1/SB0002-1/SB0003-1	2
3	Silicon Stopper for Hood	FE0001	2
4	Heat Insulator for Hood Handle	FE0031	2
5	Name Plate	ZA0017	1
6	Hood	06W06-A	1
7	Hood Handle	RSA0001	1
8	Hood Handle Connector	ZA0016	2
9	Back Burner Cover	SA0029-1	1
10	Infrared Back Burner	SD0006	1
11	Back Burner Front Frame	SA0028-1	1
12	Firebox Back – Top Panel	SA0009-1	1
13	Firebox Back Panel	SA0434-1	1
14	Bottom Heat Shield	SA0018-1	1
15	Firebox Front Panel	SA0433-1	1
16	Heat Shield –Control Panel Inner	SA0436-3	1
17	Gas Manifold Assembly	SC0016(LP Only)/SC0024(NG Only)	1
18	Control Panel	SA0435-1	1
19	Control Knob Seat	ZA0003	5
20	Control Knob	ZA0011	5
21	Firebox Rear Panel	SA0434-1	1
22	Countertop Frame	RAC0003/RAC0026/RAC0027	1
23	Warming Rack	SA0015-1	1
24	Cooking Grate (Small)	SE0004	2
24-1	Cooking Grate (Big)	SE0005	1
25	Heat Diffuser	SA0021-1	3
26	Firebox Left Side Panel	SA0432-1	1
27	Firebox Right Side Panel	SA0432-1	1
28	“U” Main Burner	SD0001-1	3
29	Main Burner Support	SA0013-1	1
30	Grease Tray	SA0301-3	1
31	Grease Cup Hook	SE0077	1
32	Grease Cup	SA0375-1	1
33	Flame Sensor Support	SA0030-1	1
34	Flame Sensor	SC0016	1
35	Back Burner Electrode	SI1350	1
36	Rotisserie Motor Support	SA0031-1	1
37	Rotisserie Spit Support	SA0032-1	1
38	Back Burner Fuel Line	SH0870	1
39	Regulator and Hose (LP Only)	SE0034	1
40	Rotisserie - Left Storage Support	SA0033-1	1

## Parts List for Models 119.166790/166830 & 119.176790/166830

KEY	DESCRIPTION	PART#	QTY
40-1	Rotisserie – Right Storage Support	SA0033-1	1
41	Manual Igniter	SE00190	1
42	Side Burner Cover	SA0437-1	1
43	Side Burner Inside Frame	SA0038-1	1
44	Side Burner Shelf Frame	SA0035-1	1
45	Side Burner Grate	CI0001	1
46	Side Burner Cap and Stem	CI0002	1
47	Side Burner Electrode	SE0052	1
48	Rotisserie Spit w/Forks and Counterweight	SE0009	1
49	Electric Igniter	SE0010	1
50	Rotisserie Motor	SE0091	1
51	Side Burner Side Panel	SA0439-1	1
52	Cabinet Back Panel (LP only)	SA0304	1
53	Cabinet Bottom Panel	SA0302	1
54	Cabinet Crossbar	SA0440	1
55	Cylinder Tray (LP only)	SA0086	1
56	Cabinet - Left Side Panel	SA0303	1
57	Cabinet - Right Side Panel	SA0303	1
58	Cabinet Left Door Crossbar	SA0445	1
59	Cabinet – Left Door Assembly	SA0305-1/SA0306-1	2
60	Cabinet – Right Door Assembly	SA0305-1/SA0306-1	1
61	Door Handle	ZA0018	7
62	Cabinet Door Divider	SA0441	1
63	Cylinder Support Ring (LP only)	SE0092	1
64	Cabinet Rail Support	SA0448	1
65	Firebox Left Support	SA0444	1
66	Locking Caster	SE0057	1
67	Caster	SE0056	1
68	Locking Swivel Caster	SE0055	5
69	Swivel Caster	SE0054	5
70	Silicon Stopper For Countertop	FE0003	12
71	Left Island Granite Countertop Insert	RHA0011	1
72	Left Island Aluminum Top Frame	RAC0026/RAC0027/RAC0003	1
73	Left Island Bottom Panel	SA0311	1
74	Top Drawer Assembly	SA0309-1/SA0310-1/SA0059-1/SA0060-1	2
75	Glide Assembly	SE0018	4
76	Drawer Glide Support	SA0449	4
77	Side Table Crossbar	SA0450	2
78	Ice Chest Back Cover	SA0082-1	1
79	Ice Chest Cover Handle	SE0013	1
80	Ice Chest Front Cover	SA0081-1	1

## Parts List for Models 119.166790/166830 & 119.176790/166830

KEY	DESCRIPTION	PART#	QTY
81	Ice Chest Liner	FE0008	1
82	Ice Chest Exterior	58002-C-4	1
83	Ice Chest Side Handle	SE0015	2
84	Ice Chest Drawer	SA0083-1/SA0084-1/SA0307-1/SA0308-1	2
85	Ice Chest Glide Assembly	SA0088	4
86	Left Island Left Side Panel	SA0312	1
87	Left Island Back Panel	SA0313	1
88	Left Island Right Side Panel	SA0314	1
89	Right Island Granite Countertop Insert	RAH0012	1
90	Right Island Aluminum Top Frame	RAC0026/RAC0027/RAC0003	1
91	Right Island Bottom Panel	SA0311	1
92	Right Island Right Side Panel	SA0315	1
93	Right Island Back Panel	SA0316	1
94	Right Island Left Side Panel	SA0317	1
95	Gas Hose (NG Only)	SE0047	1
96	Cabinet Back Panel (NG Only)	SA0501	1

### Detail Part List – Not Show In Diagram

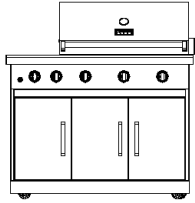
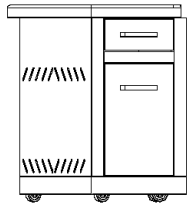
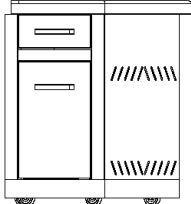
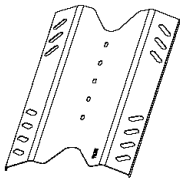
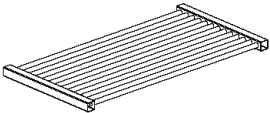
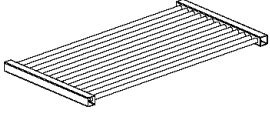

97	Grill Cover	F0005	1
----	-------------	-------	---

## Assembly Parts List for 119.166790/166830 & 119.176790/166830

Item No.	Description	Part #	Qty	Graphic
A	Grill Module Assembly	06W06-C	1	
B	Grill Island Left Assembly	06W06-D	1	
C	Grill Island Right Assembly	06W06-D	1	
D	Heat Diffuser	SA0021-1	3	
E	Small Cooking Grate 19" x 9.5"	SE0004	2	
F	Large Cooking Grate 19" x 11.5"	SE0005	1	

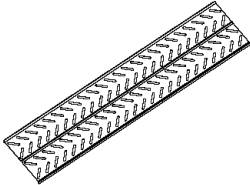
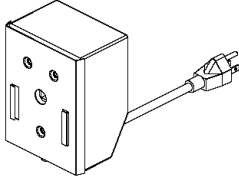

## Assembly Parts List for 119.166790/166830 & 119.176790/166830

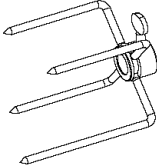
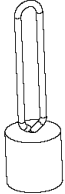
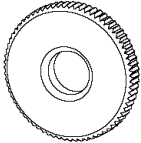
Item No.	Description	Part #	Qty	Graphic
<b>G</b>	Warming Rack	SA0015-1	1	
<b>H</b>	Rotisserie Motor	SE0091	1	
<b>I</b>	Rotisserie Spit with Handle	SE0009	1	
<b>J</b>	Meat Fork	SE0009	2	
<b>K</b>	Counterweight	SE0009	1	
<b>L</b>	Spit Washer	SE0009	2	

## Assembly Parts List for 119.166790/166830 & 119.176790/166830

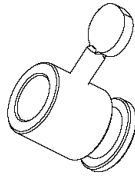
Item No.	Description	Part #	Qty	Graphic
M	Spit Bushing	SE0091	1	

## Hardware Pack Parts List 119.166790/166830 & 119.176790/166830

PART #	PART DESCRIPTION	QTY	PURPOSE OF PART
SB0064	Philips Head Bolt: M6 x 1-3/8"	4	To attach Grill Module and Islands
SB0004	Philips Head Bolt: M6 x 3/8"	4	To attach Grill Module and Islands
SB0005	Washer: M6	8	To attach Grill Module and Islands
SE0007	Battery Size AA	1	For the Electronic Igniter
SE9018+FE0014	Phillips Head Screwdriver	1	To secure all of the Bolts

## Hardware Pack Parts List 119.166790/166830 & 119.176790/166830



Philips Head Bolt: M6 x 1-3/8"  
Qty: 4  
Part # SB0064

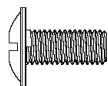

Philips Head Bolt: M6 x 3/8"  
Qty: 4  
Part # SB0004



Washer: M6  
Qty: 8  
Part # SB0005



Battery Size: AA  
Qty: 1  
Part # SE0007

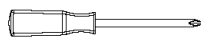

Phillips Head Screwdriver  
Qty: 1  
Part# SE9018+FE0014

# Assembly Instruction

Please refer to pages 8 through 10 for item graphics.

**1**

## Remove granite countertop.

- Remove the granite inserts from the island assemblies. Carefully push the inserts straight up out of the frame from underneath. Use caution as the granite is heavy and large in shape.

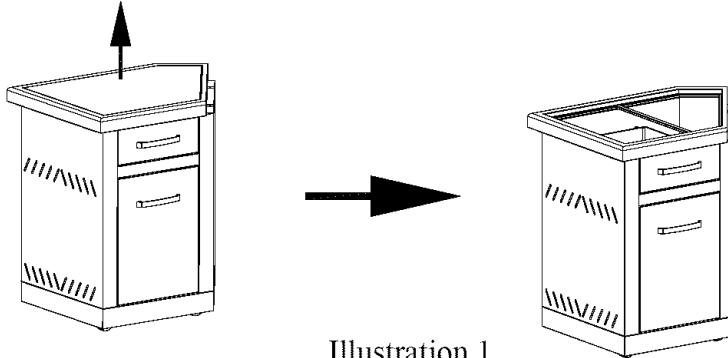

Illustration 1

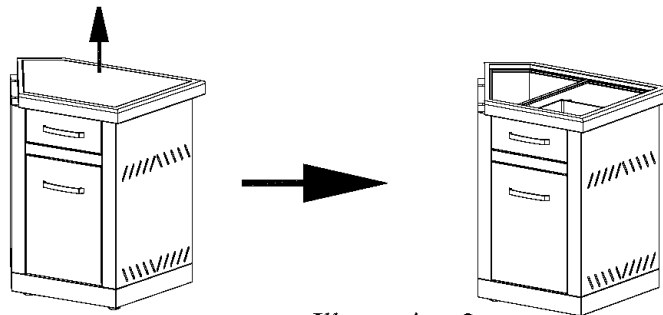
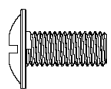

Illustration 2

**2**

## Attach Left Grill Island Assembly to Grill Module Assembly

- Attach the Left Grill Island (B) to Grill Module Assembly (A) using 2 M6 x 3/8" bolts and 2 washers. Insert the bolts from the lower inside cabinet of the Grill Module (A) into the Left Grill Island (B). See Inset 1.
- Use 2 M6 x 1-3/8" bolts and 2 washers to attach the tops of both Assemblies, this time inserting the bolts from the Left Grill Island (B) into the Grill Module (A) as shown in Inset 2.



Philips Head Bolt: M6 x 3/8"  
Qty: 2  
Part # SB0004



Philips Head Bolt: M6 x 1-3/8"  
Qty: 2  
Part # SB0064



Washer: M6  
Qty: 4  
Part # SB0005

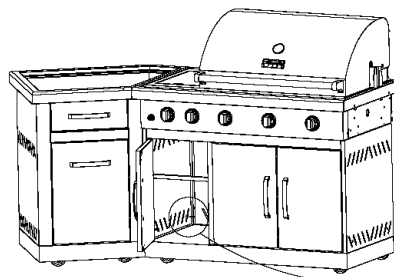

Inset 1

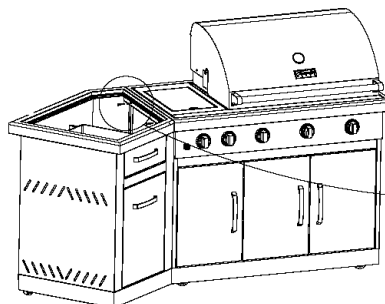

Inset 2

### 3

#### Attach Grill Island Set Right

- Attach the Grill Island Set Right (C) to Main Assembly by using 2 M6 x 3/8" bolts and 2 washers going from the Main Assembly cabinet underneath and into Grill Island Set Right as shown in Inset 1.
- Continue to attach the Grill Island Set Right (C) to the Main Assembly (A) by using 2 M6 x 1-3/8" bolts and 2 washers going from Grill Island Set Right into Main Assembly as shown in Inset 2.

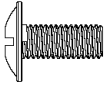

Philips Head Bolt: M6 x 3/8"  
Qty: 2  
Part # SB0004



Philips Head Bolt: M6 x 1-3/8"  
Qty: 2  
Part # SB0064



Washer: M6  
Qty: 4  
Part # SB0005

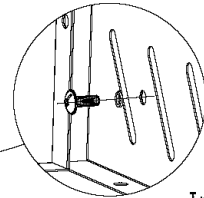
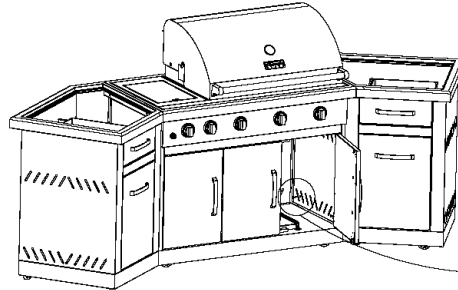

Inset 1

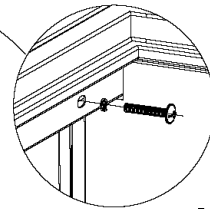
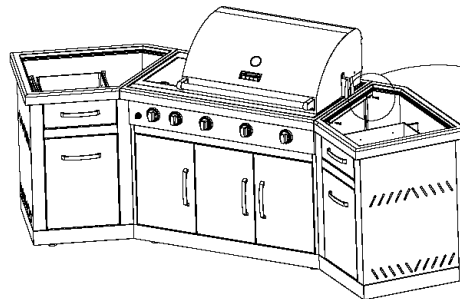

Inset 2

### 4

#### Insert the Granite Countertops for Left & Right Grill Island Assemblies.

- Replace the left and right granite countertop inserts using caution not to damage them.

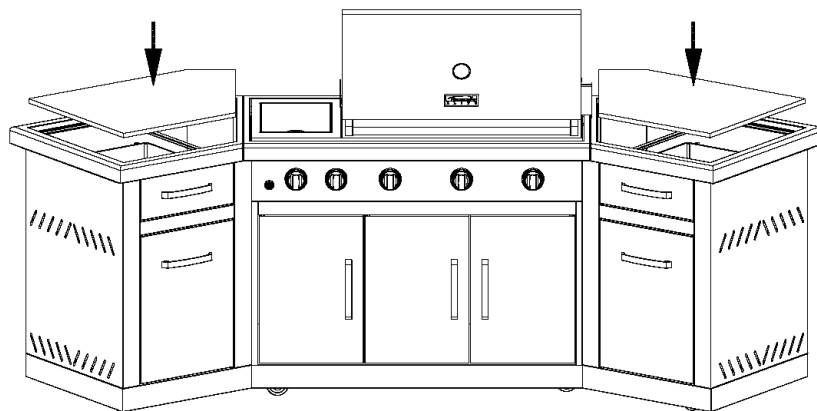

**5****Insert the Heat Diffusers into the Firebox**

- Insert the 3 Heat Diffusers (D) inside the firebox. Ensure the fronts of the Heat Diffusers, which are stamped "Front" on the Heat Diffusers, are at the front of the firebox. The sides of the Heat Diffusers fit down into slots on the front and back of the firebox to secure them in place. See the Inset.

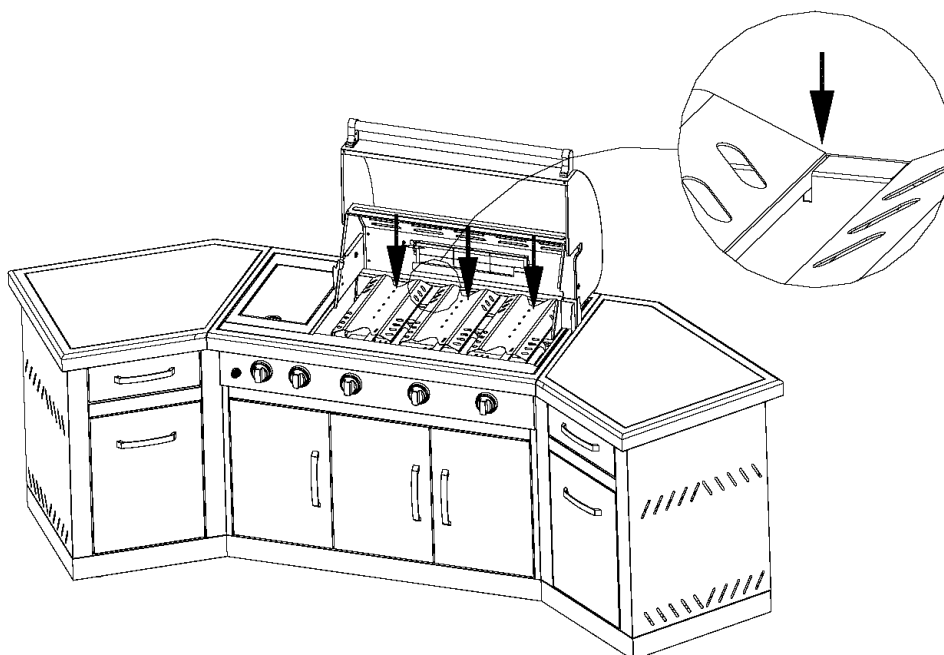
**6****Insert the Cooking Grates into the Firebox**

- Insert the 2 Small Stainless Steel Cooking Grates (E) and 1 Large Cooking Grate (F) into the firebox. The grates sit on the front and back lips of the firebox. There are 2 small and 1 large grates, which can be inserted in any order.

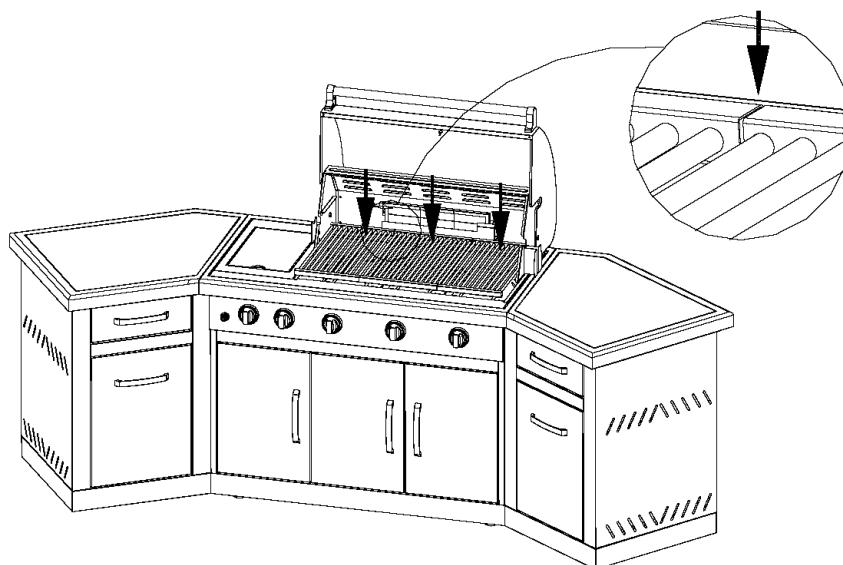

**7****Insert the Warming Rack into the Firebox**

- Place the Warming Rack (G) into the slots on the upper sides of the firebox. Be sure the sides of the Warming Rack fit down into the slots to secure it in place.

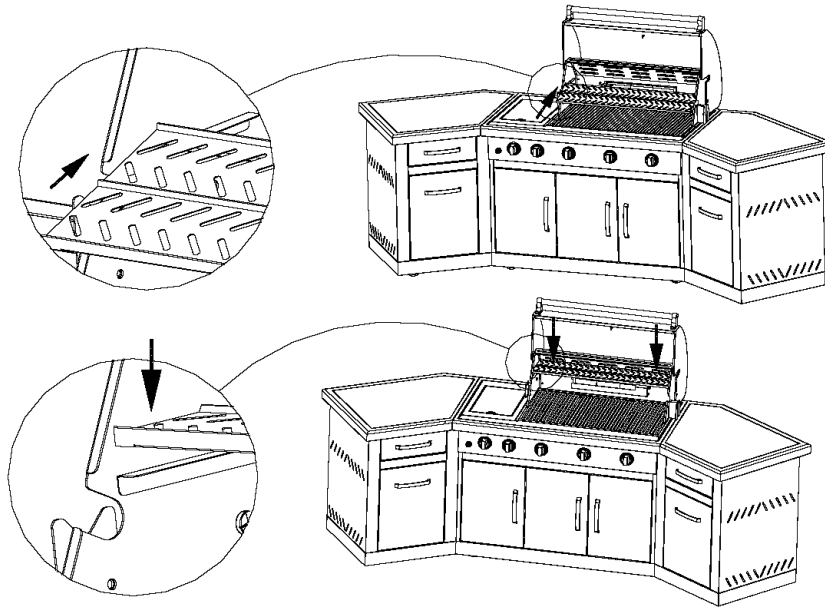
**8****Install Rotisserie Motor**

- Slide the Rotisserie Motor (H) onto the mounting bracket on the right side of the firebox sidewall
- Note: We recommend you store the Rotisserie Motor in one of the drawers when not in use.  
Do not use the Rotisserie Motor in rain or expose to moisture.

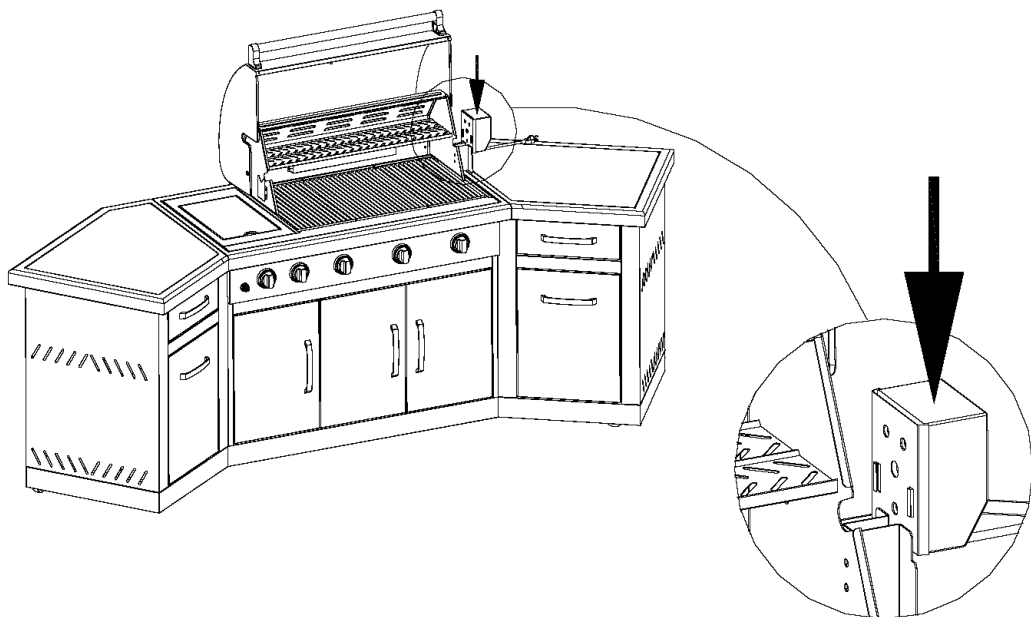

**9****Assemble the Rotisserie Spit Assembly**

- Slide one Washer (L) onto the handle end of the spit, followed by the counterweight (K), and the second Washer (L). Tighten the washers to secure the counterweight. See Inset 1. Then slide the Bushing (M) on the spit followed by the 2 Meat Forks (J). Tighten the thumbscrews on the Meat Forks. Use caution as the forks are sharp. See Inset 2.

Inset 1

Inset 2

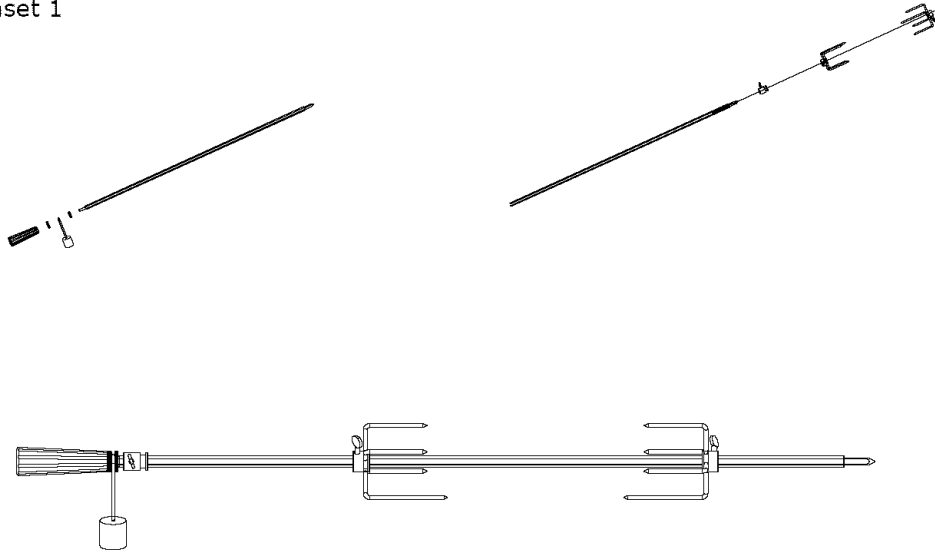
**10****Install Rotisserie Spit Assembly onto the Firebox**

- Slide the Spit Assembly into place by inserting the pointed end into the Rotisserie Motor (H), and placing the bushing into its bracket on the left firebox sidewall. See Insets 1 and 2.

Note: We recommend you store the Counterweight and Forks in a drawer when not in use. A holder is located on the back of the firebox for Spit storage.

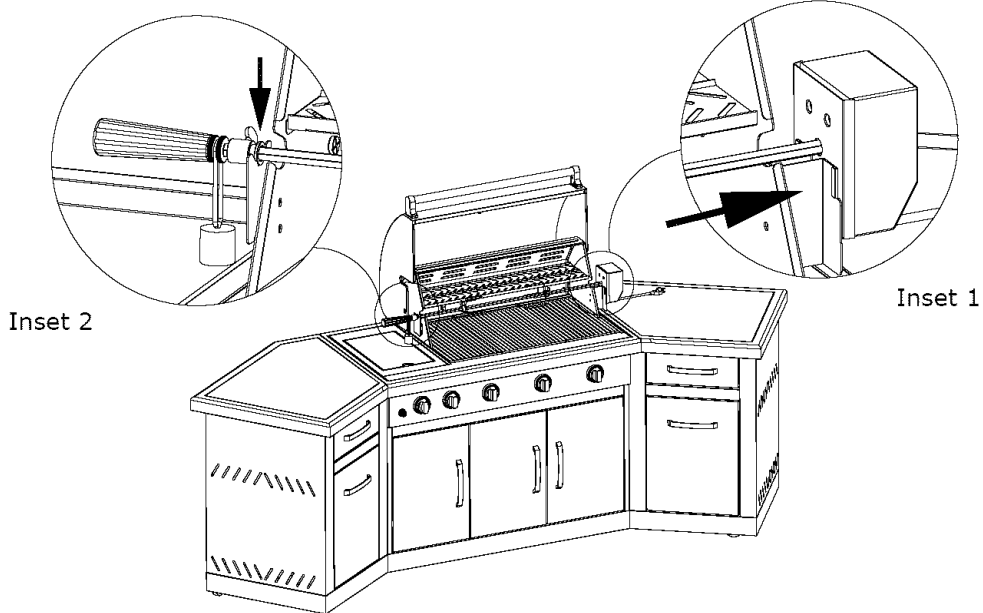

**11****Install Battery**

- Unscrew the electronic igniter cap. Place the "AA" Battery into the electronic igniter with the Positive (+) end facing up.
- Screw the electronic igniter cap back into place on the electronic igniter.

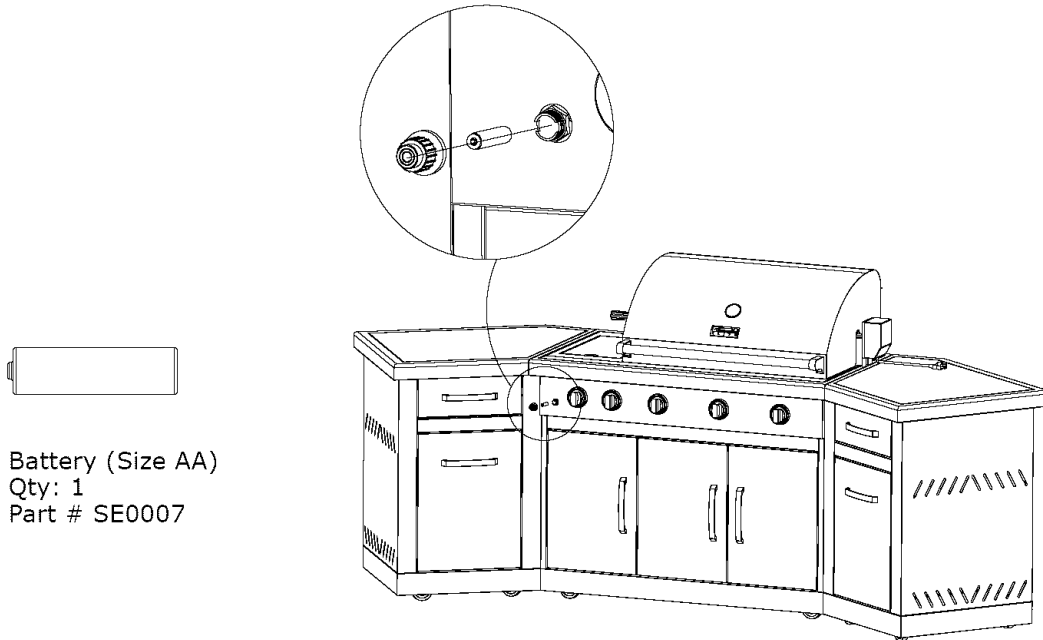
**12****Place LP Cylinder into the Cabinet (LP Model Only)**

- Pull the cylinder tray out from the cabinet. Place the LP cylinder down into the tank support hole. Ensure the valve faces toward the left. Raise the LP cylinder support ring and unhook as shown as you push the cylinder tray back into the cabinet. Lock the cylinder tray in place and lower the LP cylinder support ring over the top of the LP cylinder. Wrap around the neck of the cylinder and rehook to secure the LP cylinder in place.

**Do Not Hook Up the LP Cylinder to the Regulator Assembly at this time.**

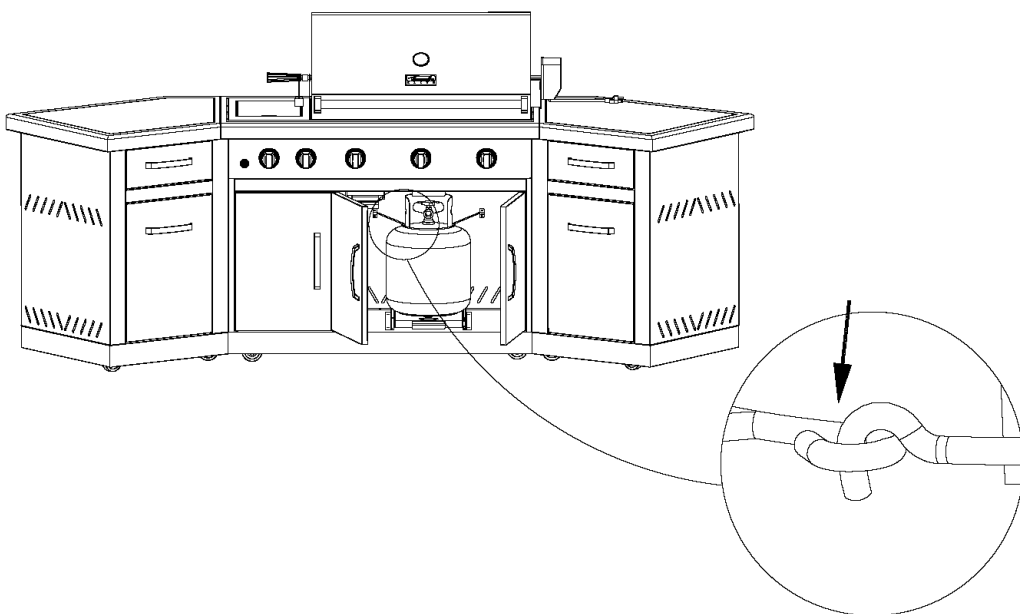



**13**

**Gas Hose Preparation (NG Model Only)**

- Feed the Nature Gas Hose out through the back of the cabinet.  
**Do Not Hook Up the Natural Gas Hose to your Gas Line at this time.**

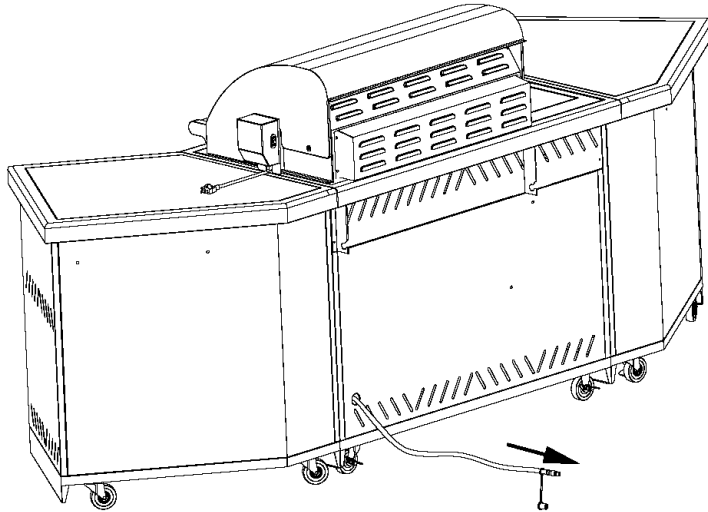

**14**

**Congratulations- Assembly is now Complete**

- Remove any additional packing from the grill. Be sure to clean all foam packing material out of all areas.

Congratulations! Your grill is now fully assembled. Please proceed and read the General Information and Operation portion of the Operator's Manual before attempting to hook up the LP cylinder (for LP model only) or a Gas supply (NG model only) or operating your grill.

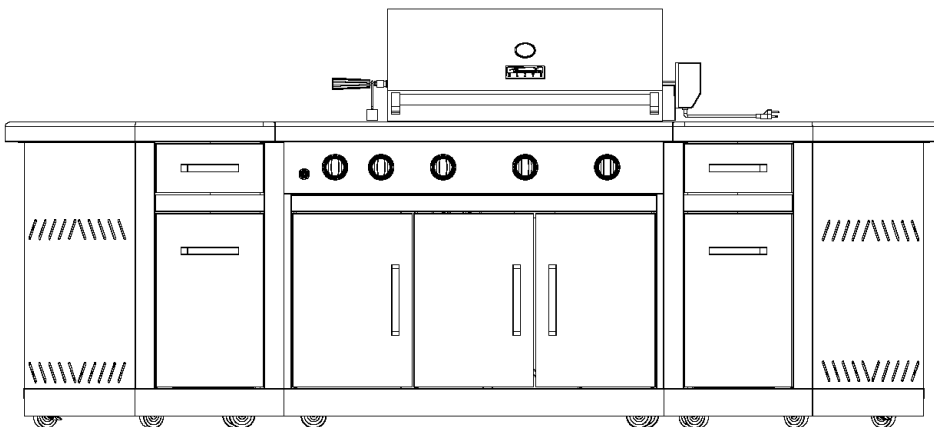



## LP Gas Tank Installation (For LP Model Only)

### CORRECT LP GAS TANK USE

- LP gas grill models are designed for use with a standard 20 lb. (9.1kg) Liquid Propane Gas (LP G) tank, which is not included with the grill. Never connect your gas grill to an LP gas tank that exceeds this capacity. A tank of approximately 12" (305mm) in diameter by 18-1/2"(472mm) high is the maximum size LP gas tank to use. You must use an "OPD" gas tank which offers a listed Overfill Prevention Device. This safety feature prevents tanks from being overfilled which can cause malfunction of the LP gas tank, regulator and grill.
- The LP gas tank must be constructed and marked in accordance with the Specifications for LP-Gas Cylinders of the U.S. Department of Transportation (D.O. T.) or the National Standard of Canada, CAN/CSA-B339, Cylinders, Spheres and Tubes for Transportation of Dangerous Goods; and Commission, as applicable.
- The LP gas tank must have a shutoff valve terminating in a LP gas supply tank valve outlet that is compatible with a Type 1 tank connection device. The LP gas tank must also have a safety relief device that has a direct connection with the vapor space of the tank.
- The tank supply system must have a means for vapor withdrawal.
- The LP gas tank used must have a collar to protect the tank valve.
- Never** connect an unregulated LP gas tank to your gas grill. The gas regulator assembly supplied with your gas grill is adjusted to have an outlet pressure of 11"water column (W.C.) for connection to an LP gas tank. Only use the regulator and hose assembly supplied with your gas grill. **Replacement regulators and hose assemblies must be those specified by Sears.** See the Parts List.
- Have your LP Gas dealer check the release valve after every filling to ensure it remains free of defects.
- Always keep the LP gas tank in an upright position. Do not subject the LP gas tank to excessive heat.
- Never** store an LP gas tank indoors. If you store your gas grill indoors, **always** disconnect the LP gas tank first and store it safely outside.
- LP gas tanks must be stored outdoors in a well-ventilated area and out of the reach of children.
- Disconnected LP gas tanks must not be stored in a building, garage, or any other enclosed area.
- The regulator and hose assembly can be seen after opening the door (if applicable) and must be inspected before each use of the grill. If there is excessive abrasion or wear or if the hose is cut, it must be replaced prior to using the grill.
- Never** light your gas grill with the lid closed or before checking to ensure the burner tubes are fully seated over the gas valve orifices.
- Never** allow children to operate your grill. Do not allow children or pets to play near your grill.



- Use of alcohol or drugs may impair the ability to assemble and operate the appliance.
- Keep a fire extinguisher readily accessible. In the event of an oil or grease fire, do not attempt to extinguish with water. Use a type B extinguisher or smother with dirt, sand, or baking soda.
- In the event of rain, cover the grill and turn off the burner and gas supply.
- Use your grill on a level, stable surface and ensure the locking casters are locked before use.
- Do not leave the grill unattended when in use.
- Do not move the appliance when in use.
- Allow the grill to cool before moving or storing.
- Do not use your grill as a heater.
- This grill is not intended to be installed in or on recreational vehicles and /or boats.

 **WARNING** 

A. Do not store a spare LP gas tank under or near this appliance.

B. Never fill the tank beyond 80 percent full;

C. If the information in "(A)" and "(B)" is not followed exactly, a fire causing death or serious injury may occur.

 **WARNING** 

- **Use your grill at least 2 feet away from any wall or surface .** Use your grill at least 2 feet away from combustible objects that can melt or catch fire (such as vinyl or wood siding, fences and overhangs) or sources of ignition including pilot lights on water heaters and live electrical appliances.
- **Never** use your gas grill in a garage, porch, shed, breezeway, or any other enclosed area.
- **Never** obstruct the flow of ventilation air around your gas grill housing.

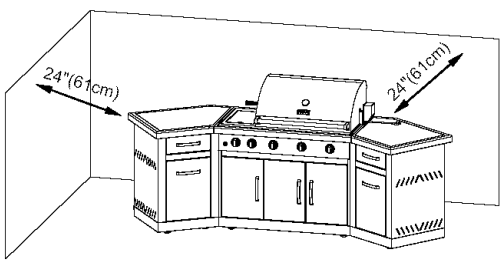

## LP Gas Tank Installation (For LP Model Only)

### Notes about LP Gas Tank Exchange Programs

- Many retailers that sell grills offer you the option of replacing your empty LP gas tank through an exchange service. Use only those reputable exchange companies that inspect, precision fill, test and certify their tanks. Exchange your tank only for an OPD safety feature equipped tank as described in the LP gas tank section of this manual.
- Always keep new and exchanged LP gas tanks in an upright position during use, transit or storage.
- Leak test new and exchanged LP gas tanks BEFORE connecting one to your grill.

### How to Leak Test your LP Gas Tank

#### For your safety:

- All leak tests must be repeated each time your LP gas tank is exchanged or refilled.
  - Do not smoke when checking for gas leaks.
  - Do not use an open flame to check for gas leaks.
  - Your grill must be leak tested outdoors in a well-ventilated area, away from ignition sources such as gas fired or electrical appliances. During the leak test, keep your grill away from open flames or sparks.
  - Do not use household cleaning agents as damage to gas assembly components can occur.
- Use a clean paintbrush and a 50/50 mild soap and water solution.
- Brush soapy solution onto the LP gas tank in the areas indicated by the arrows. See diagram.
- If growing bubbles appear do not use or move the LP Gas tank. Call an LP gas supplier or your fire department.

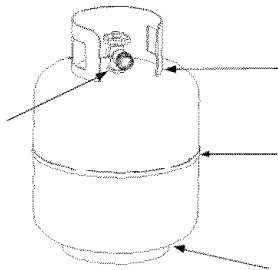

**WARNING**

If growing bubbles appear do not use or move the LP Gas tank. Contact an LP gas Supplier or your fire department!

### Regulator and LP Cylinder Connections

**WARNING**

The gas pressure regulator provided with this outdoor cooking appliance must be used. This regulator is set for an outlet pressure of 11 inches water column.

Your regulator is equipped with a Q.C.C. Type 1 quick connect system. It will not allow gas to flow until a positive seal has been made. It has a thermal element that will shut off the gas flow if the temperature reaches 240 degrees F (115 degrees C). It also has a flow-limiting device that will restrict the flow of gas to 10 cubic feet per hour (0.28 cubic meters per hour).

#### TO CONNECT THE CYLINDER TO THE REGULATOR AND HOSE

1. Be sure the LP cylinder is "OFF" by turning the hand wheel clockwise until it stops.
2. Place the cylinder into the base cabinet shelf of the grill with the valve facing outward and secure with the cylinder support ring.
3. Be sure all burner controls are turned to the "OFF" position.
4. Remove the safety cap from the cylinder valve.
5. Center the nipple of the regulator into the cylinder valve.
6. Turn the black nut clockwise until it stops.  
**Hand Tighten Only. Do Not Use A Wrench.**

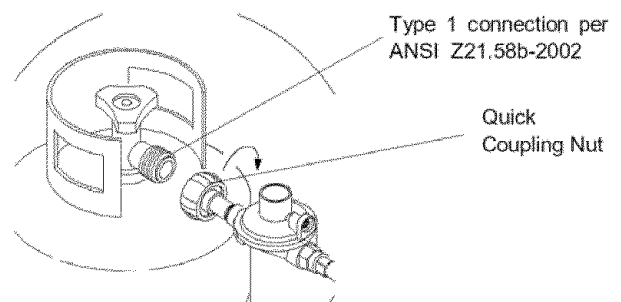

**CAUTION:** When the appliance is not in use the gas must be turned off at the tank.

## LP Gas Tank Installation (For LP Model Only)

### Flow Limiting Valves on LP Gas Tanks

Your LP gas tank is equipped with a flow limiting valve that will restrict the flow of gas due to a sudden change in pressure. This can often activate without your knowledge. You will notice among other things that your grill does not get as hot as it should, will take longer to heat up, or you may not be able to light all burners. If you notice any of the above, then you should reset the valve and clear your gas line.

To do this

1. Ensure the LP gas tank valve is OFF.
2. Disconnect the regulator from the LP gas tank.
3. Open all burner control knobs including the side burner to Hi/Light at the same time.
4. Close all burner control knobs to OFF.
5. Let the LP gas tank stand for at least 10 minutes.
6. Reconnect the regulator assembly to the LP gas tank.
7. Slowly, meaning about 1/4 turn at a time, turn on the LP gas valve.
8. Follow the burner lighting procedures to light the burner farthest away from the gas source.
9. The flow limiting valve should now be reset.

This flow limiting valve is triggered by sudden changes in pressure. This can be caused by a leak, faulty connection of the regulator to the LP gas tank, turning on the LP gas tank valve too quickly, or turning the burners off by turning the LP gas tank valve off before turning the burner control knobs to off. Note: always turn off your burners using the burner control knobs first before turning the LP gas tank valve off.

### Transportation and Storage

1. Place a dust cap on the cylinder valve outlet whenever the cylinder is not in use. Only install the type of dust cap on the cylinder valve outlet that is provided with the cylinder of propane valve. Other types of caps or plugs may result in leakage.
2. Always transport your cylinder in an upright position.
3. Do not smoke when transporting your cylinder.

### Check all connections for LP Gas Leaks

- Never** test for leaks with a flame. Prior to first use, at the beginning of each season or every time your LP Gas tank is changed you must check for gas leaks. Follow these three steps:
- Make a soap solution by mixing one part liquid detergent and one part water
- Turn the burner control knobs to the OFF position. Then turn the gas ON at the source.
- Apply the soap solution to all gas connections indicated by the arrows. See diagram. If bubbles appear in the soap solution the connections are not properly sealed. Check each fitting and tighten or repair as necessary

Gas Valve Manifold Assembly

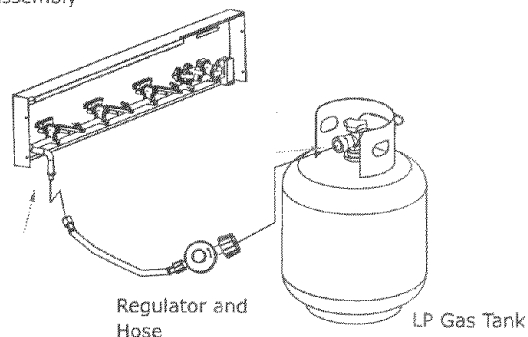

⚠ **WARNING** ⚠

If you have a gas leak that cannot be repaired by tightening, turn off the gas at the source, disconnect fuel line from your grill and call 1-800-4-MY-HOME® or your gas supplier for repair assistance.

### Disconnecting A Liquid Propane Gas (LPG) Tank From Your Grill

- Make sure the burner valves and LP gas tank valve are off. (Turn clockwise to close.)
- Detach the hose and regulator assembly from the LP gas tank valve by turning the quick coupling nut counterclockwise

## Natural Gas Information (For NG model only)

Your new gas grill operates on Natural Gas. It is colorless and odorless in its natural form. The form of natural gas that is delivered to your home is almost pure methane.

Your grill is designed to operate on natural gas only. Do not, for safety reasons, use any other type of fuel.

Your grill operates at 7" water column pressure. Contact your local gas utility for the gas pressure in your area.

Contact your local municipality for any building code requirements in your area.

### NATURAL GAS CONNECTION

A shut-off valve should already be installed at the gas source outside of the house or where the pipe exits the ground. If not, then one must be installed before installing the quick-disconnect hose for your grill.

Attach the quick-disconnect socket to the shut-off valve. Use pipe dope or pipe thread tape on the male pipe thread.

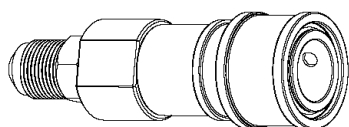

Push the male fitting from the gas hose into the quick-disconnect socket. Push in the plug until the sleeve from the socket snaps forward locking the plug in place. This will activate the flow of gas if the shut-off valve is turned on.

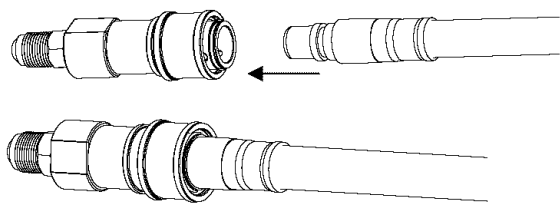

Disconnect the plug by pushing the sleeve back towards the socket.

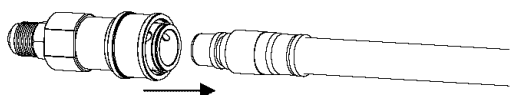

Use of alcohol or drugs may impair the ability to assemble and operate the appliance.

Keep a fire extinguisher readily accessible. In the event of an oil or grease fire, do not attempt to extinguish with water. Use a type B extinguisher or smother with dirt, sand, or baking soda.

In the event of rain, cover the grill and turn off the burner and gas supply.

Use your grill on a level, stable surface and ensure the locking casters are locked before use.

Do not leave the grill unattended when in use.

Do not move the appliance when in use.

Allow the grill to cool before moving or storing.

Do not use your grill as a heater.

This grill is not intended to be installed in or on recreational vehicles and /or boats.

### WARNING

- Do not store a gas tank under or near this appliance.
- If the information in "(a)" is not followed exactly, a fire causing death or serious injury may occur.

### WARNING

- Use your grill at least 2 feet away from any wall or surface .** Use your grill at least 2 feet away from combustible objects that can melt or catch fire (such as vinyl or wood siding, fences and overhangs) or sources of ignition including pilot lights on water heaters and live electrical appliances.
- Never** use your gas grill in a garage, porch, shed, breezeway, or any other enclosed area.
- Never** obstruct the flow of ventilation air around your gas grill housing.

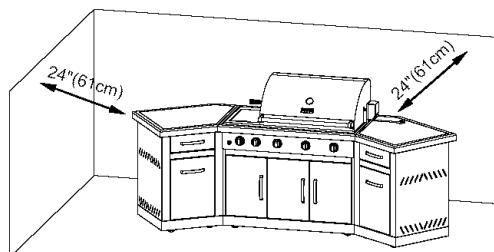

## Natural Gas Information (For NG model only)

### For your safety:

- A leak test must be repeated each time your NG gas line is connected
- Do not smoke when checking for gas leaks.
- Do not use an open flame to check for gas leaks.
- Your grill must be leak tested outdoors in a well-ventilated area, away from any ignition source such as gas fired or electrical appliances. During the leak test, keep your grill away from open flames or sparks.
- Do not use household cleaning agents as damage to gas components can occur.

### How to do Leak Test on your NG Grill

1. Ensure all burners are "Off"
2. Ensure the gas hose is connected to the gas source, and the shutoff valve is turned on.
3. Mix up a solution of 50% dish soap and 50% water. Do not use any household cleaner solution.
4. Spray or brush on the solution covering the following area: gas hose connections to the shut-off valve, gas hose, and the gas hose connection to the gas manifold assembly. Growing bubbles on any of the parts and connections listed above indicate a gas leak.

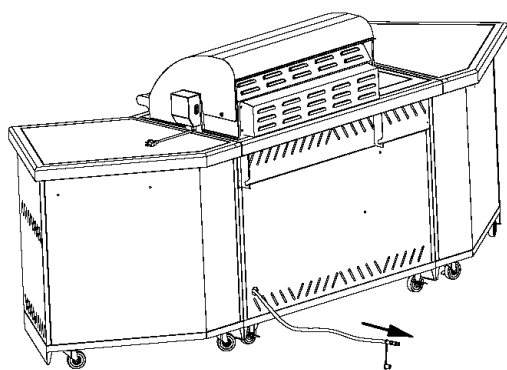

### WARNING

1. DO NOT USE THE GRILL if you cannot stop a leak.
2. Do not use any match or open flame, or smoke, during leak testing.
3. Do not light a burner during leak testing.

### WARNING

1. Before each use, check the natural gas hose for excessive abrasion, wear or cuts. Replace a gas hose showing those signs with the hose specified in the parts list before using the grill. Inspect the hose by opening the cabinet door underneath the right main burner and following the gas hose up to its connection to the gas manifold assembly.
2. Always perform the Leak Test listed above before using your grill for the first time, if the natural gas connection has been changed, any gas components have been changed, or after a long period of non-use.

### WARNING

1. This outdoor cooking gas appliance and its individual shutoff valve must be disconnected from the gas supply piping system during any pressure testing of that system at test pressures in excess of 0.5psi (3.5kPa).
2. This outdoor cooking gas appliance must be isolated from the gas supply piping system by closing its individual manual shutoff valve during any pressure testing of the gas supply piping system at test pressures equal to or less than ½ psi (3.5kPa).

### WARNING

If you have a gas leak that cannot be repaired by tightening, turn off the gas at the source, disconnect fuel line from your grill and call 1-800-4-MY-HOME® or your gas supplier for repair assistance.

# USE AND CARE INSTRUCTIONS

## Main Burner Instructions

### Lighting The Main Burners With Push And Turn Ignition

1. Before each use, check all hoses for cracks, nicks, cuts, or abrasions. If a hose is damaged in any way, do not use your grill before replacing the hose with an authorized part from the Parts List. Also make sure all gas supply connections are securely tightened.
2. Familiarize yourself with the Safety and Use and Care instructions in this manual. Do not smoke while lighting the grill or checking gas supply connections.
3. Be sure the LP gas tank has gas.
4. Open the grill lid.
5. Check that the end of each burner tube is properly located over each valve orifice.



## WARNING



Failure to replace a faulty hose, secure gas supply connections, or to open the lid before proceeding to the Lighting Procedures could result in a fire or explosion that could cause serious bodily injury, death, or property damage.

## Side Burner and Back Burner Lighting Instructions

### Lighting The Side Burner Or Back Burner With Electronic Ignition

Follow steps 1 through 5 of the Grill Lighting Instructions.

1. Open side burner or grill lid.
2. Set control knobs to OFF and open the LP gas tank valve SLOWLY or turn on the natural gas.
3. Push and turn the side or back burner control knob to "HI/LIGHT".
4. Immediately press the electric igniter button for 3-5 seconds to light the burner. You should hear a clicking sound which shows the electronic ignition is working.
5. If the burner does not light within 5 seconds, turn the burner control knob to "Off". Wait 5 minutes for the gas to clear, and repeat the above procedure.
6. For the back burner, continue to push and hold the burner control knob in for 5 to 7 seconds after the burner lights until the flame sensor begins operating. Letting up on the burner control knob before a high enough temperature has been reached may cause the flame sensor to shut off fuel to the back burner.

6. Set Control Knobs to OFF and open the LP gas tank valve SLOWLY or turn on the natural gas.

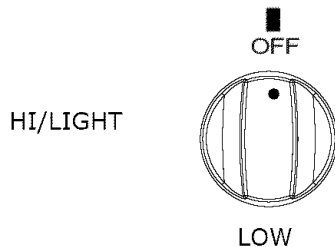

7. Push in the burner control knob of the burner you wish to light and turn left to "HI/LIGHT". You will hear a click as a spark is sent to the burner. If the burner does not light, then turn back to "OFF", and repeat this procedure. Continue this process until the burner lights.

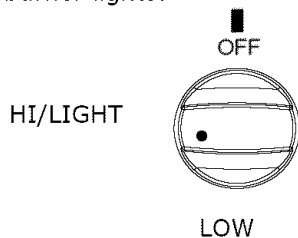

8. When lit, turn the burner control knob to its desired heat setting.

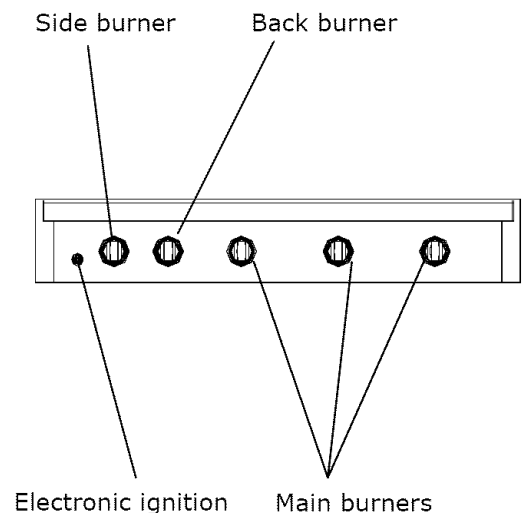

## USE AND CARE INSTRUCTIONS

### MANUALLY LIGHTING THE MAIN BURNERS WITH THE MATCH HOLDER

1. Open the lid.
2. Ensure all burners are in the "OFF" position.
3. Slowly turn on the gas at the LP cylinder valve or natural gas valve if it is not already on.
4. Place a match in the match light stick. This is located in the inner cabinet door.
5. Use the stick to slide the lit match through the cooking grates and the front of the heat diffuser to the burner you wish to light.
6. Press and turn the burner control knob to "HI/LIGHT". Continue to push in and hold up to 5 seconds or until the burner lights.
7. If the burner does not light within 5 seconds, turn the burner control knob to "OFF". Wait 5 minutes for gas to clear, and try again.
8. When lit, turn the control knob to the desired heat setting.

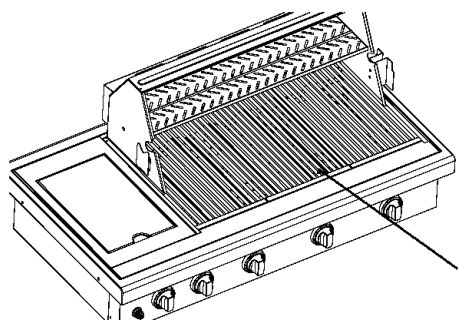

### MANUALLY LIGHTING THE SIDE BURNER OR BACK BURNER

1. Open the lid or the side burner cover.
2. Ensure the side and back burner control knob is in the "OFF" position as well as any main burner not in use.
3. Slowly turn on the gas if it is not already on.
4. Place a match in the match holder if lighting the back burner. This is located in the top center drawer of the grill cabinet underneath the center main burner.
5. Strike the match and place near the top of the burner if lighting the side burner or near the center of the back burner if lighting the back burner.
6. Push in and turn the appropriate burner control knob to "HI/LIGHT" and hold in.
7. If the burner does not light within 5 seconds, turn the burner control knob to "OFF". Wait 5 minutes for the gas to clear, and try again.
8. For the back burner, continue to push and hold the burner control knob in for 5 to 7 seconds after the burner lights until the flame sensor begins operating. Letting up on the burner control knob before a high enough temperature has been reached may cause the flame sensor to shut off fuel to the back burner.
9. When lit, turn the burner control knob to its desired setting.

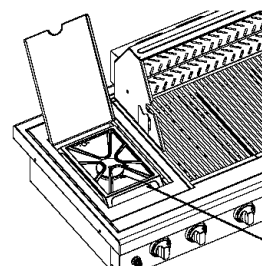

### WARNING



1. Do not use charcoal briquettes, lava rock, or any type of ceramic product in this grill.
2. Do not put a barbecue cover or other flammable material in the storage area of this grill.

**Never** lean over the grill cooking area while lighting your gas grill. Keep your face and body a safe distance (at least 18 inches) from the lighting hole and burners when lighting your grill with a match.

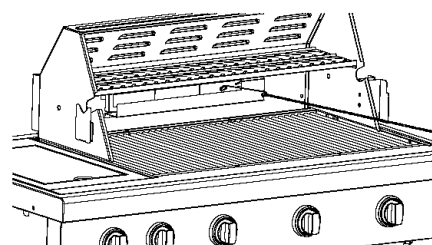



## USE AND CARE INSTRUCTIONS

### TROUBLESHOOTING

#### If the grill fails to light:

1. Turn gas off at source and turn control knobs to "OFF". Wait at least 5 minutes for gas to clear, and then retry
  2. If your grill still fails to light, check the gas supply and connections. Ensure gas supply is turned on (turn counterclockwise), there is gas in the tank, and the regulator is properly seated in the tank valve.
  3. Repeat lighting procedure. If your grill still fails to light, turn the gas off at the source, turn the control knobs to "OFF", and check the following:
- Obstruction in Gas Line  
**Correction:** Detach regulator hose assembly or natural gas hose. Do not smoke! Open all control knobs at the same time to "High". Close all burner control knobs to "OFF" and reattach the regulator hose assembly or natural gas hose to the grill.
  - Plugged Orifice or Burner Tube Obstruction  
**Correction:** Remove burners from grill and clean following the burner cleaning instructions later in this manual. Observe valve orifices to be sure there is no obstruction visible.
  - If an obstruction is suspected in a Gas Valve or Manifold, call the Customer Support Center.
  - Misalignment of Igniter and Burner  
**Correction:** Check for proper position of the electrode tip. The gap between the electrode tip and burner should be approximately 3/16 of an inch. Adjust if necessary. With the gas supply off and all control knobs set to "OFF" press the electric igniter button and check for the presence of a spark at the electrode.
  - Disconnected Electric Wires  
**Correction:** Inspect the electric igniter (see Parts List) found behind the control panel. Connect loose electric wires to ignition assembly.
  - Weak AA Battery  
**Correction:** Unscrew the igniter cap and replace the battery.



### WARNING

Do not dispose of batteries in fire! Batteries may explode or leak.

- If the grill still does not light you may need to reset the flow limiting valve in your LP tank.  
**Note:** This procedure should be done every time a new LP gas tank is connected to your grill.

#### Follow the steps below to reset the flow limiting device.

Turn LP gas tank valve "OFF".

Disconnect the regulator assembly from LP Gas tank.

Open all burner control knobs to "HI/LIGHT" at the same time.

Close all burner control knobs to "OFF"

Let the LP Gas tank stand for at least 10 minutes.

Reconnect the regulator assembly to the LP Gas tank.

Slowly turn on the LP Gas tank valve.

Follow the burner lighting procedures to light the burner farthest away from the gas source.



### WARNING



Should a FLASHBACK fire occur in or around the burner tubes, follow the instructions below. Failure to comply with these instructions could result in a fire or explosion that could cause serious bodily injury, death, or property damage.

- Shut off gas supply (turn the LP tank valve clockwise) to the gas grill.
- Turn the control knobs to the "OFF" position.
- Open the grill lid.  
Put out any flame with a Class B Fire extinguisher
- Once the grill has cooled down, clean the burner tubes and burners according to the cleaning instructions in this Operator's Manual.

#### Customer Support Center

Call 8:30 AM to 5:00 PM CST **1-800-933-0527** Monday through Friday.

## ELECTRONIC IGNITION MAINTENANCE

Your grill is equipped with electronic ignition for the back and side burners. It's powered by one "AA" size battery. Replace the battery when necessary. Unscrew the igniter top. Place the new battery into the igniter with the positive (+) end of the battery facing up. Screw the igniter top back into place. Also inspect for cracks and replace as necessary.

## GRILL STORAGE

- Clean your grill before storage.
- Storage of a gas grill indoors is permissible only if the cylinder is disconnected and removed from the gas grill.
- Cover the grill.
- Perform a Leak Test before use after storage.

## CLEANING AND MAINTENANCE

Proper care and maintenance will keep your grill in good operating condition and prolong its life. Follow these cleaning procedures on a timely basis and your grill will stay clean and operate with minimum effort.

**CAUTION:** Be sure your grill is off and cool before cleaning, and always wear protective gloves when cleaning your grill

### Cleaning The Cooking Grates

Wash your cooking grates in a mild soap and warm water solution. You can use a wash cloth, vegetable brush, or brass bristled brush. Never use any type of steel bristled brush. Dry them when finished.

### Cleaning the Heat Diffusers

Wash the heat diffusers periodically in a soap and warm water solution. Use a vegetable brush to remove stubborn burnt-on cooking residue. Dry the heat diffusers thoroughly before you reinstall them into the firebox.

### Cleaning the Grease Tray and Pan

To reduce the chance of fire, the grease tray and grease pan should be visually inspected before each grill use. Remove any grease and wash both with a mild soap and warm water solution.

### Cleaning the Inside of the Grill Lid

Grease can have a tendency to build up on the inside of the grill lid and could drip onto the deck or patio when the lid is opened. Visually inspect the inside of the grill lid before each grill use. Remove any grease and wash with a mild soap and warm water solution.

### Annual Cleaning of the Grill Interior

Burning-off excess food after every cookout will keep it ready for instant use. We recommend you periodically give the entire grill a thorough cleaning to minimize your risk of grease fire and keep the grill in good shape. Follow these steps:

1. Turn all burner valves to the "OFF" position.
2. Turn the LP gas tank valve to the "OFF" position or shut off the natural gas.
3. Disconnect the regulator assembly or gas hose. Inspect the hose for cracking, cuts or any other damage, and replace as necessary. Refer to the Parts List in this Operator's Manual.
4. Remove and clean the cooking grates, heat diffusers, warming rack, burners, and grease tray.
5. Cover each gas valve orifice with aluminum foil.
6. Brush the inside and bottom of the grill with a fiber pad or nylon brush and wash with a mild soap and warm water solution. Rinse thoroughly and let dry.
7. Remove aluminum foil from orifices and check each orifice for obstruction. Replace the burners, ensuring the burners fit down over each valve orifice.
8. Replace the burners, ensuring the burners fit down over each valve orifice.
9. Check and clean each electrode tip. Adjust the spacing between the tips and the burner as necessary. The space between the electrode tip and burner should be approximately 3/16".
10. Replace the heat diffusers, grates, warming rack, and grease tray.
11. Reconnect the gas source and observe the burner flame for correct operation.

### Cleaning Exterior Surfaces:

#### Cleaning Exterior Surfaces:

Wash with a mild dish soap and warm water solution. A cloth, soft brush, or plastic cleaning pad can be used. Rinse thoroughly and wipe dry.

#### Cleaning Exterior Stainless Steel Surfaces:

Wash with a mild dish soap and warm water solution. Clean and polish with a stainless steel cleaner. There are many good quality stainless steel cleaners and polishes available. Follow the manufacturer's directions. Always polish in the direction of the lines. Do not allow dirt and grease to accumulate. Do not use steel wool as it will scratch the surface. Do not use abrasive cleaners and scrubbers.

### CAUTION:

Heat, weathering, machine oils used in the manufacturing of stainless steel, and dirt can all cause exterior stainless steel surfaces to turn tan in color. In addition, the following products and naturally occurring substances in the outdoors will damage all stainless steel finishes. Use caution so they will not come in contact with your grill. Immediately wash them off and dry the stainless steel should they ever come in contact with your gas grill. They include, but are not limited to, pool chemicals (chlorine and bromine), lawn fertilizer, ice melting salts, sea or salt water, urine, bird droppings, and tree sap.

## CLEANING THE BURNER TUBES AND BURNER PORTS

To reduce the chance of **FLASHBACK FIRE** you must clean the burner tubes as follows periodically in summer and fall, wherever spiders are active in your area, and if your grill has not been used for an extended period of time.

1. Turn all burner control knobs to the "OFF" position.
2. Turn the LP Tank or Natural Gas valve to the "OFF" position.
3. Disconnect the regulator assembly or natural gas hose from the gas supply.
4. Remove the cooking grates, heat tents, grease cup, and grease tray from the grill.
5. Remove the screw from the rear of each burner using a Phillips head screwdriver.
6. Carefully lift each burner up and away from the gas valve orifice.
7. Check and clean burner tubes for insects and insect nests. A clogged tube can lead to a fire beneath the grill.

**METHOD 1:** Use a bottle brush with a flexible handle and run the brush through the burner tube and inside the burner several times to remove any debris.

**METHOD 2:** Use an air hose to force air through each burner tube. The forced air should pass debris or obstructions through the burner and out the ports. Always wear eye protection if using this method.

### **WARNING**

Small insects, such as spiders, are able to access the burner tubes. Sometimes they will build nests or spin webs. In either case, this can block or reduce the amount of gas flowing through the burner. You will usually see a smaller flame, or a flame that is mostly yellow rather than blue, coming from the burner when this happens. Other signs include the grill not heating evenly, not reaching temperature, or burners not igniting. In cases with severe blockage, this can cause the flame to burn backwards, and outside of the burner tubes, which can cause damage to your grill and/or personal injury. **IMMEDIATELY SHUT OFF THE FLOW OF GAS AT THE LP TANK OR NATURAL GAS VALVE SHOULD THIS HAPPEN.** Wait for the grill to cool, and then clean all burners.

Regardless of the burner cleaning procedure you use, we recommend you also complete the following steps to help prolong burner life.

1. Use a fiber pad or nylon brush to clean the entire outer surface of each burner until free of food residue and dirt.
2. Clean any clogged ports with a stiff wire, such as an open paper clip.
3. Inspect each burner for damage (cracks or holes) and if such damage is found, order and install a new burner. After installation, check to ensure that the gas valve orifices are correctly placed inside the ends of the burner tubes. Also check the position of your electrodes.
4. Never enlarge the burner ports during cleaning.

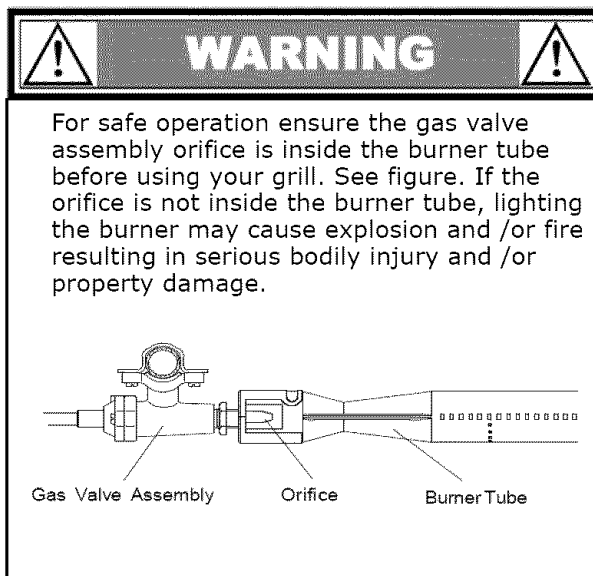

### BURNER FLAMES

Always inspect the burner flame after lighting. A good flame should be primarily blue with a yellow tip and have a minima amount of noise. Some yellow tips are OK if under one inch. New burners sometimes have oil residue, which will cause yellow flame when burning off. Variations in gas supply, altitude, weather, and other factors can all impact burner performance. Older grills can also show more yellow flame as food deposits, oils, and fats can build up

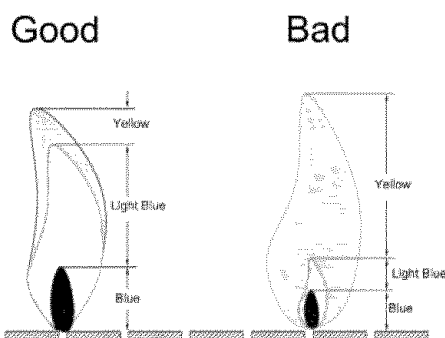

## Cooking Instructions

### Burn-Off

Some of the new parts of your grill could have residual oils. We recommend you ignite the burners, turn to "HI", and lower the lid for 3 to 5 minutes to burn any oils off before grilling for the first time.

**CAUTION:** Operating your grill on the "HI" setting for longer than five minutes may damage certain parts of your grill.

### Preheating

To preheat, light your grill on "HI/LIGHT", lower the lid and follow this timetable: for high temperature cooking, preheat grill 3 to 5 minutes. for low temperature cooking, preheat grill 3 minutes. To slow cook, preheating is not necessary.

### Cooking Temperature

**High Setting:** The "HI" control knob setting should only be used to sear some meats, pre-heat your grill the first 3-5 minutes and for burning food residue off the grill for 3-5 minutes after cooking is complete. Never use the "HI" setting for extended cooking.

**Medium to Low Settings:** Most recipes specify medium to low settings, including all smoking and rotisserie cooking, lean cuts of meat, chicken, and fish.

### An Important Note About Cooking Temperature

The outside grilling area is not the controlled environment that your indoor kitchen is. Many variables can impact the cooking performance of your grill, including outside air temperature, wind, humidity, and altitude. Allow more cooking time for cold, wind, and higher altitudes. We recommend you place the grill in an area protected from wind. Monitor your grill closely and rotate foods as needed to prevent overcooking and ensure the most delicious results every time. Experimenting makes grilling more fun and interesting!

The middle and back primary cooking areas offer the highest heat for searing and grilling.

The warming rack offers medium heat for preparing breads and firm vegetables like potatoes and corn and keeping food warm.

The front primary cooking area offers less heat and is ideal for preparing delicate foods and also for keeping cooked foods warm.

### Direct Cooking

The direct cooking method is used when food is placed directly over the lit grill burners. This method is ideal for searing, grilling, deep frying and whenever you want foods to have an open-flame barbecued taste. The lid can be open or closed depending on your preference.

### Indirect Cooking

The indirect cooking method is used for most foods. Do not place the food directly over a burner to use this method. Instead, the food should be placed on the left or right side of your grill with the burner lit on the opposite side or in the center with the center burners off. Indirect cooking must be done with the lid down.

### Prepare Cooking Grates for Grilling

Greasing the cooking surface will help keep foods from sticking and reduce the amount of cleanup required. Use a brush to apply a thin layer of cooking oil or vegetable shortening onto each cooking grate. We do not suggest spray type oils unless they are specified for high-temperature cooking. Be sure to coat the entire cooking surface including edges and any areas with chipped porcelain.

### Flare-Ups

The fats and juices dripping from grilled food can cause flare-ups. Flare-ups work to color and flavor your foods, so some flare-ups are preferred. Too many can work against you though. Reduce flare-ups by trimming away excess fat, using the indirect method of grilling, and grilling using lower temperatures.

### USING THE REMOVABLE ICE CHEST

Your gas grill comes with a removable stainless steel ice chest with a plastic liner. This ice chest is designed to keep beverages and product in sealed containers cool for a short period of time. We recommend you do not store food in this ice chest.



Failure to comply with these instructions may result in a hazardous situation which, if not avoided, may result in injury.

Keep grill area clear and free from combustible materials, gasoline and other flammable vapors and liquids.

Do not obstruct the flow of air for combustion and ventilation.

Keep the ventilation openings of the tank enclosure cabinet free and clear of debris.

## Cooking Instructions

### OPERATING THE ROTISSERIE

1. Install the rotisserie motor onto the mounting bracket.
2. Slide the counterweight on the spit rod between 2 washers next to the handle, followed by the bushing. Then slide one meat fork on with the tongs pointing towards the tip of the spit.
3. Skewer the meat onto the spit rod, and slide to the center. You want to balance the weight as evenly as possible.
4. Slide on the second meat fork with the prongs facing the meat.
5. Center the meat and slide both meat forks into the meat. Tighten the setscrews on the forks.
6. Check the balance of the food on the spit by rotating it loosely in your hands. The spit rod should rotate evenly with little effort. Adjust the food on the spit to balance as necessary.
7. Place the spit into the motor and support bracket. Be sure the bushing rests on the support bracket. Note that you will need to remove the warming rack and possibly the grates depending on the size of the food you are cooking.
8. Plug in the rotisserie motor, and turn "On". Ensure the spit is rotating freely and evenly. Adjust the meat and counterweight as necessary. Turn "Off" once balanced.
9. Place a pan under the food to catch the drippings from rotisserie cooking. Do not allow the drippings to fall down into the firebox. Again, it may be necessary to remove the cooking grates.
10. Open the hood and light the back burner following the instructions earlier in this Grill Guide.  
**DO NOT USE ANY OF THE MAIN BURNERS WHEN USING THE BACK BURNER.**
11. Close the hood and adjust the burner control knob for the back burner to the setting you prefer.
12. Turn the motor "Off" when opening the hood to inspect the meat or when done before removing the spit.
13. When finished, clean the spit and meat forks with warm water and dish soap and dry. Store the meat forks and motor in a drawer where they will not get wet. Storage hooks for the spit are located on the back of the firebox.

### USING THE ROTISSERIE

The Rotisserie Motor that comes with this grill must be grounded in accordance with local codes, or in the absence of local codes, with the National Electrical Code, ANSI/NFPA 70-1990.

#### ELECTRICAL GROUNDING INSTRUCTIONS

This appliance is equipped with a three-prong grounded plug for your protection. It should be plugged directly into a properly grounded three-prong receptacle. Do not cut or remove the grounding prong from this plug.

#### **WARNING**

1. Do not operate your Rotisserie Motor in the rain, or expose it to moisture. Store it in a dry place when not in use.
2. Use caution when handling the spit rod and meat forks, as their ends are sharp. Use insulated protective mitts or potholders as rotisserie parts and food become hot during use.
3. Keep out of reach of children.
4. Do not operate with a damaged cord or plug.
5. Turn motor switch to "OFF" before removing from outlet.
6. Unplug the rotisserie motor when not in use.
7. Do not use the main burners or side burner when using the rotisserie.

#### **WARNING**

Do not use the infrared back burner when the main burners are in use. Remove the warming rack when the back burner and rotisserie are in use.

## FREQUENTLY ASKED QUESTIONS

**Question:**

**Can I convert my gas grill from one fuel type to another, such as LP to NG (natural gas) or vice versa?**

**Answer:**

No, your gas grill is manufactured to specific standards developed by CSA and ANSI for your safety and is certified for LPG (Liquid Propane Gas) or NG (Natural Gas) use only.

**Question:**

Are the serial and model numbers of my grill listed somewhere for reference?

**Answer:**

The serial and model numbers are listed on a silver CSA label placed on the grill. Depending on the grill model, the silver CSA label generally will be located on the back panel of the cart.

**Question:**

**My grill will not light properly. Why?**

**Answer:**

Check these possibilities:

1. The gas supply is turned off at the LP Cylinder or Natural Gas valve. Turn on LP Cylinder or the gas at the Natural Gas source.
2. Your LP Cylinder is out of propane.
3. Crimped fuel supply hose. Inspect and straighten.
4. Regulator failure or damaged hose assembly. Inspect and order a replacement part. Do not use your grill if you find a damaged hose assembly.
5. Gas not getting to the burners. Inspect the burners under the control panel to be sure they are aligned with the valve orifices.
6. Blockage in the gas system. Inspect burners and valve orifices for blockages, such as spider webs, insects, etc. Clean as necessary.

**Question:**

**My electronic ignition is not working.**

**Answer:**

Listen to hear the electronic igniter clicking. If not, check these possibilities:

1. Replace the AA battery. Ensure the "+" end is facing up and out.
2. Ensure the battery is centered and fits into the electronic igniter button properly.
3. Be sure the wires are all attached to the electronic ignition assembly behind the control panel and the individual burner electrodes.
4. Inspect the electrodes to be sure they are not coated with grease or dirt. If so, clean with rubbing alcohol.

If you hear a clicking sound, then:

1. Inspect the electrodes to be sure they are not coated with grease and dirt. Clean with rubbing alcohol.
2. Inspect the distance from the electrode to the burner. It should be 1/8 to 1/4 inch from the main burner and 1/8 to 3/16 inch from the side burner.

**Question:**

Sometimes I hear a humming sound coming from my regulator. What causes this?

**Answer:**

The humming sound is gas flowing through the regulator. This is more likely to occur in periods of high gas flow. A low volume of sound is normal and will not interfere with the operation of your grill.

**Question:**

My grill has a low flame on some burners, or some burners will not light at all. What can cause this?

**Answer:**

This can be caused by the flow limiting device, which is generally triggered by a sudden change in pressure. Opening the tank valve too fast or shutting the burners off using the tank valve can cause this. To reset:

1. Close the LP Tank valve and disconnect the regulator assembly from the tank.
2. Let the LP Tank sit for 10 minutes.
3. Open all burner control knobs, including the side burner, to "HI" at the same time.
4. Close all burner control knobs.
5. Reconnect the gas regulator to the LP tank.
6. Follow the burner lighting procedures and light the burner farthest from the LP tank.

**Question:**

Where do I use my grill for safer operation and better performance?

**Answer:**

Strong winds and low temperatures can affect the heating and performance of your gas grill so factor in these elements when positioning your grill outdoors for cooking.

Use your grill at least 2 feet away from any wall or surface.

## FREQUENTLY ASKED QUESTIONS

Use your grill at least 2 feet away from combustible objects that can melt or catch fire (such as vinyl or wood siding, fence and overhangs) or sources of ignition including pilot lights on water heaters and live electrical appliances.

Never use your gas grill in a garage, porch, shed, breezeway or any other enclosed area.

Never obstruct the flow of ventilation air around your gas grill housing.

### Question:

The Regulator and Hose supplier with my gas grill does not fit the older LP Gas Tank I've used for years. Why not?

### Answer:

The U.S. Government regulates gas appliances and LP gas tanks. When regulations are changed the LP gas tank fittings are altered to insure compliance. If your LP gas tank does not fit the regulator and hose assembly supplied with your new grill, then the tank is outdated and must be replaced. Note: Effective April 1, 2002 all LP gas tanks sold must include an "OPD" Overfill Prevention Device. The OPD tanks are identified by their triangular-shaped valve wheel. This internal device prevents the LP gas tank from being overfilled. Tanks without an OPD valve can no longer be refilled.

### Question:

**Is it safe to clean my porcelain coated cooking grates in the dishwasher?**

### Answer:

No. We recommend you clean all parts of your grill, including the cooking grates by hand.

### Question:

**Can I clean parts of my grill, such as the cooking grates and heat tents, in a self-cleaning oven?**

### Answer:

No. You should not clean any part of your grill in a self-cleaning oven.

### Question:

**What can I do to keep my cast iron grates from rusting?**

### Answer:

Cast iron grates do require special care. We recommend you first season new grates. Wash new grates with dishwashing liquid, rinse, and dry completely with a soft cloth. Never wash them in a dishwasher. We recommend you use a solid vegetable shortening over the grates to season them the first time. Spread a thin coating

with a paper towel over the entire surface, corners, and edges. Preheat your grill to 500 degrees. Turn half your burners to "LOW" and half "OFF", and place the grates in the firebox for about an hour. Shut off all burners and allow the grates to cool. We recommend you coat the grates with a liquid vegetable oil before each use. We do not suggest spray type oils unless they are specified for high temperature cooking.

### Repair Protection Agreements

Congratulations on making a smart purchase. Your new Kenmore® product is designed and manufactured for years of dependable operation. But like all products, it may require repair from time to time. That's when having a Repair Protection Agreement can save you money and aggravation.

### Purchase a Repair Protection Agreement now and protect yourself from unexpected hassle and expense.

Here's what's included in the Agreement:

- ☑ **Expert service** by our 12,000 professional repair specialists
- ☑ **Unlimited service and no charge** for parts and labor on all covered repairs
- ☑ **Product replacement** if your covered product can't be fixed
- ☑ **Discount of 10%** from regular price of service and service-related parts not covered by the agreement; also, 10% off regular price of preventive maintenance check
- ☑ **Fast help by phone** – phone support from Sears technician on products requiring in-home repair, plus convenient repair scheduling

Once you purchase the Agreement, a simple phone call is all that it takes for you to schedule service. You can call anytime day or night, or schedule a service appointment online.

Sears has over 12,000 professional repair specialists, who have access to over 4.5 million quality parts and accessories. That's the kind of professionalism you can count on to help prolong the life of your new purchase for years to come. Purchase your Repair Protection Agreement today!

**Some limitations and exclusions apply. For prices and additional information call 1-800-827-6655.**

For Sears professional installation of home appliances, garage door openers, water heaters, and other major home items, in the U.S.A. call **1-800-4-MY-HOME®**

# Get it fixed, at your home or ours!

## Your Home

For repair – **in your home** – of **all** major brand appliances, lawn and garden equipment, or heating and cooling systems, **no matter who made it, no matter who sold it!**

For the replacement parts, accessories and owner's manuals that you need to do-it-yourself.

For Sears professional installation of home appliances and items like garage door openers and water heaters.

**1-800-4-MY-HOME®** (1-800-469-4663)

Call anytime, day or night (U.S.A. and Canada)

[www.sears.com](http://www.sears.com)      [www.sears.ca](http://www.sears.ca)

---

## Our Home

For repair of carry-in items like vacuums, lawn equipment, and electronics, call or go on-line for the location of your nearest

**Sears Parts & Repair Service Center**

**1-800-488-1222**

Call anytime, day or night (U.S.A. only)

[www.sears.com](http://www.sears.com)

---

To purchase a protection agreement (U.S.A.)  
or maintenance agreement (Canada) on a product serviced by Sears:

**1-800-827-6655** (U.S.A.)

**1-800-361-6665** (Canada)

---

Para pedir servicio de reparación  
a domicilio, y para ordenar piezas:

**1-888-SU-HOGAR®**  
(1-888-784-6427)

Au Canada pour service en français:

**1-800-LE-FOYER<sup>MC</sup>**  
(1-800-533-6937)  
[www.sears.ca](http://www.sears.ca)



® Registered Trademark / ™ Trademark / SM Service Mark of Sears Brands, LLC  
© Marca Registrada / ™ Marca de Fábrica / SM Marca de Servicio de Sears Brands, LLC  
MC Marque de commerce / MD Marque déposée de Sears Brands, LLC

© Sears Brands, LLC