



# Zoneline<sup>®</sup> Air Conditioners

*Safety Instructions* .....2

*Operating Instructions*

Air Direction .....4  
Auxiliary Controls .....5-9  
Controls .....3  
To Remove the Room Cabinet ..4  
Vent Control .....4

*Care and Cleaning*

Air Filters .....11  
Base Pan .....10  
Outdoor Coils .....10  
Room Cabinet and Case .....10  
Vent Filter .....10

*Installation Instructions*

Electrical Connection .....14-17  
Installing the Zoneline .....18, 19  
Optional Drain Kit .....20  
Preparation .....12  
Replacing an Existing Unit? ...13

*Troubleshooting Tips* ....21, 22

Normal Operating Sounds ...23

*Consumer Support*

Consumer Support ...Back Cover  
Product Registration .....25, 26  
Warranty .....27

**Owner's Manual and  
Installation Instructions**

*Heat/Cool Model 2800  
Heat Pump Model 3800*

**Español**

For a Spanish version of this manual, visit our Website at ge.com.

Para consultar una version en español de este manual de instrucciones, visite nuestro sitio de internet ge.com.

**Française**

For a French version of this manual, visit our Website at www.electromenagersge.ca.

Pour une version française de ce manuel d'utilisation, veuillez visiter notre site web à l'adresse www.electromenagersge.ca.

**Write the model and serial numbers here:**

**Model #** \_\_\_\_\_

**Serial #** \_\_\_\_\_

Find these numbers on a label behind the room cabinet on the base pan.



## **IMPORTANT SAFETY INFORMATION. READ ALL INSTRUCTIONS BEFORE USING.**

### **⚠ WARNING!**

*For your safety, the information in this manual must be followed to minimize the risk of fire or explosion, electric shock, or to prevent property damage, personal injury, or loss of life.*



### **SAFETY PRECAUTIONS**

- This Zoneline must be properly installed in accordance with the Installation Instructions before it is used. See the Installation Instructions in the back of this manual.
- Replace immediately all electric service cords that have become frayed or otherwise damaged. A damaged power supply cord must be replaced with a new power supply cord obtained from the manufacturer and not repaired. Do not use a cord that shows cracks or abrasion damage along its length or at either the plug or connector end.
- Unplug or disconnect the Zoneline at the fuse box or circuit breaker before making any repairs.

**NOTE:** We strongly recommend that any servicing be performed by a qualified individual.

#### ***Replacing an existing unit?***

For details, see the Installation Instructions in this manual.



***READ AND FOLLOW THIS SAFETY INFORMATION CAREFULLY.***

**SAVE THESE INSTRUCTIONS**

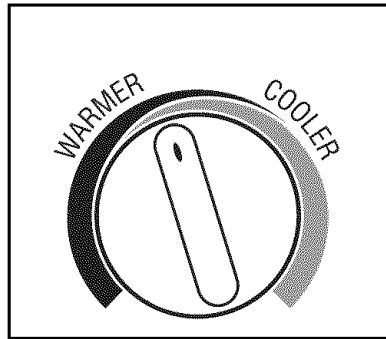

**TEMP CONTROL**

1

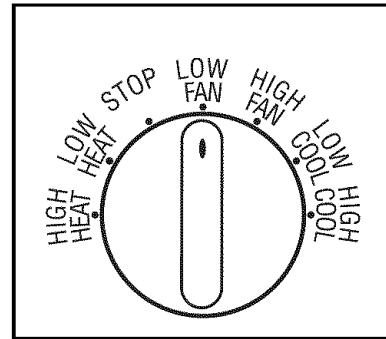

**MODE CONTROL**

2



## Controls

### 1 Temp Control

The temp control is used to maintain the room temperature. The compressor will cycle on and off to keep the room at the same comfort level. When you turn the knob to **COOLER** (blue), the indoor air will become cooler. Turn the knob to **WARMER** (red) and the indoor air will become warmer.

#### 3800 Series only

When the outdoor temperature is lower than 20°F, heat is provided by the electric heater in the air conditioner instead of by the heat pump.

### 2 Mode Control

**HIGH COOL** and **LOW COOL** provide cooling with different fan speeds.

**HIGH HEAT** and **LOW HEAT** provide heating with different fan speeds.

**LOW FAN** or **HIGH FAN** provides air circulation and filtering without cooling or heating.

**NOTE:** If you move the switch from a cool or heat setting to **STOP** or to a fan setting, the unit has an automatic 3-minute delay before allowing the compressor to restart in the cool or heat mode.

## About Your Heat Pump (3800 Series only)

Heat pumps can save money by removing heat from the outside air—even when the outside temperature is below freezing—and releasing that heat indoors.

To get the best performance from your heat pump, don't change the room thermostat very often. Raising the heat setting 2–3 degrees will cause the Zoneline to use its electric heating elements in order to reach the new temperature setting quickly.

There is a three minute minimum compressor run time at any setting to prevent short cycling.

The indoor fan motor starts before the compressor and stops after the compressor cycles off.

The electric heating elements use much more electricity than heat pumps and cost more to operate.

## Quick Heat Recovery

Activates each time the thermostat is switched from **STOP** or a **COOL** mode to a **HEAT** mode. Electric heaters are energized until the thermostat set point is reached. On heat pump models, the heat pump operation will resume at the next call for heat.

## Other features of your Zoneline.

### Ventilation Control

The ventilation control lever is located at the upper left side of the Zoneline unit, behind the room cabinet.

When set at the closed position, only the air inside the room is circulated and filtered.

When set at the open position, some outdoor air will be drawn into the room. This will reduce the heating or cooling efficiency.

**Energy Tip:** Keep the vent control at the closed position. The room air will be filtered and circulated.

**NOTE:** Two shipping screws must be removed from the vent door before use. See the Installation Instructions in the back of this manual.

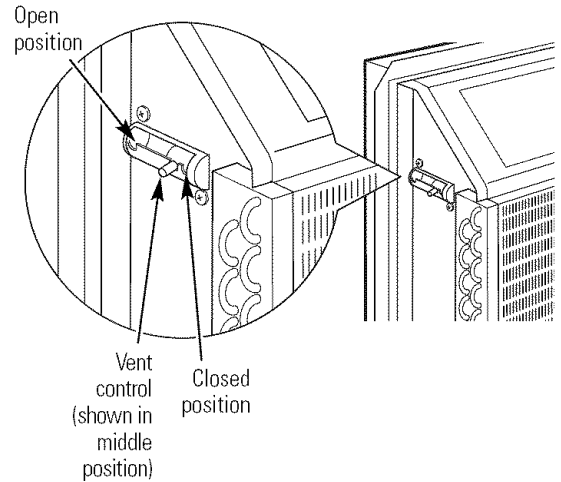

### To Remove the Room Cabinet

Additional controls are located behind the room cabinet.

**To remove:** Pull out at the bottom to release it from the tabs (1). Then lift up (2).

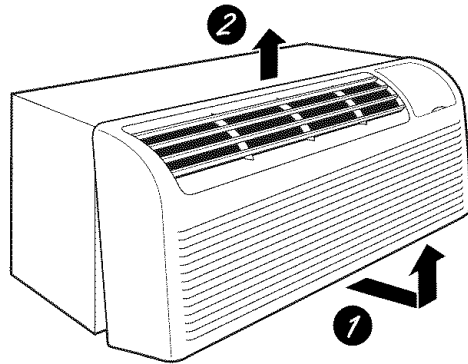

**To replace:** Place the tabs over the top rail (1). Push inward at the bottom until it snaps into place (2).

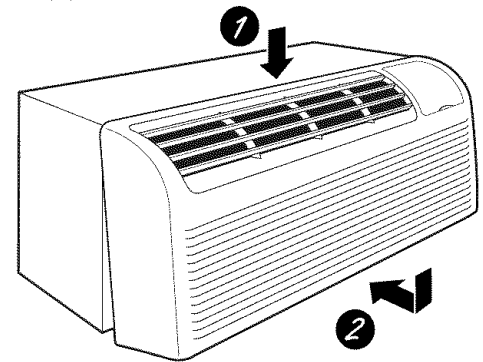

### Air Direction

To adjust the air direction, remove the room cabinet. Remove the 7 louver screws that hold the louver insert in place. Flip the louver insert 180°, replace the screws and the room cabinet.

Remove the room cabinet and flip the louver insert to change the air direction.

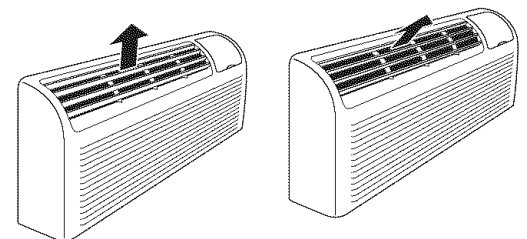
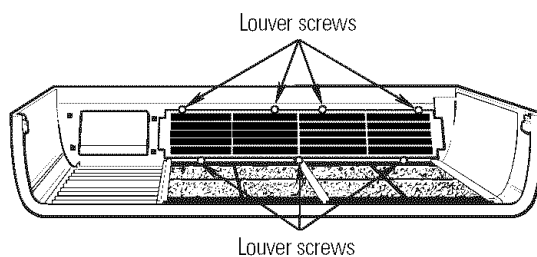

# Auxiliary Controls on your Zoneline.

ge.com

## Auxiliary Controls—Dip Switches

The auxiliary dip switch controls are located behind the room cabinet, through an opening in the control panel.

Remove the room cabinet. See the *To Remove the Room Cabinet* section.

The owner is responsible for checking switches and ensuring they are in the desired position.

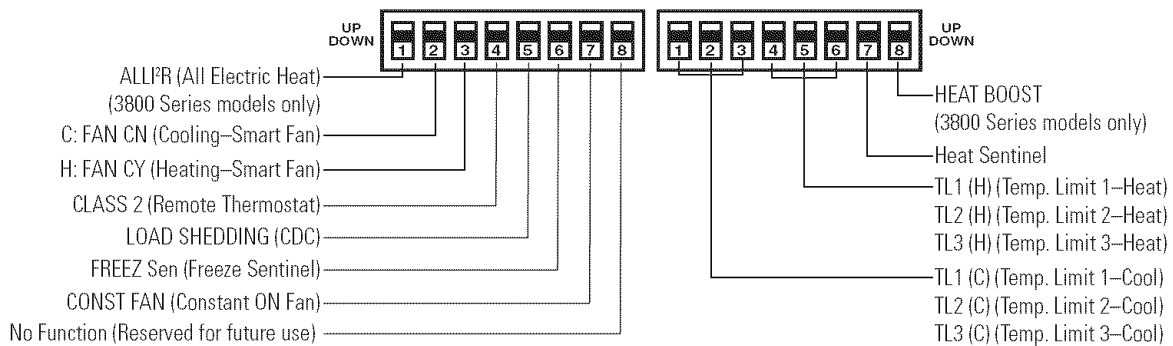
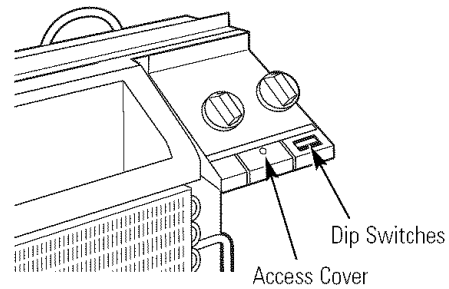

## All Electric Heat

This electric heat option functions only on the 3800 Series models. When this switch is enabled (**UP**), heat pump operation is locked out, causing the unit to provide only electric resistance heat.

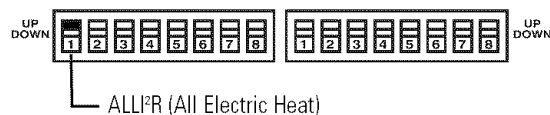

## Cooling—Smart Fan

When this switch is enabled (**UP**), it allows the indoor fan to cycle on/off with the compressor. When this switch is disabled (**DOWN**), it allows the indoor fan to run continuously.

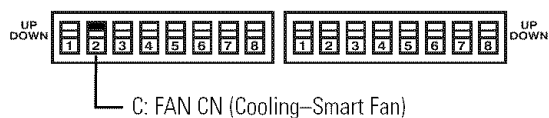

## Heating—Smart Fan

When this switch is enabled (**UP**), it allows the indoor fan to run continuously. When this switch is disabled (**DOWN**), it allows the indoor fan to cycle on/off with the heat pump or heater operation.

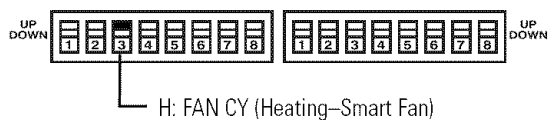

Safety Instructions

Operating Instructions

Care and Cleaning

Troubleshooting Tips

Consumer Support

## Auxiliary controls on your Zoneline.

### Remote Thermostat—Class 2

When this switch is enabled (**UP**), it allows the unit to operate with a Class 2 Remote Control Wall Thermostat. The unit controls are disabled.

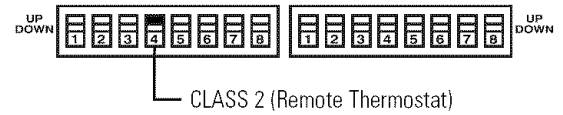

### Load Shedding (Central Desk Control)

This feature is active only if the unit is in CDC mode. When this switch is enabled (**UP**), the indoor fan can be turned ON or OFF with the unit controls.

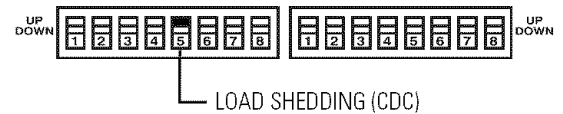

### Freeze Sentinel

When this switch is enabled (**UP**), it turns OFF the freeze sentinel protection feature. With the switch disabled (**DOWN**), the freeze sentinel is activated, which automatically provides heat without user interface. This helps to prevent plumbing damage by turning the heater and indoor fan ON at 41°F and OFF at 46°F.

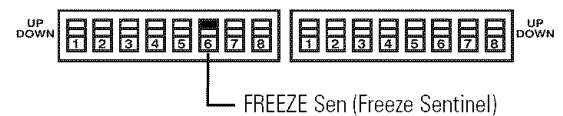

### Constant ON Fan

When this switch is enabled (**UP**), it allows the indoor fan to run continuously, at high speed, even if the unit is in the STOP position.

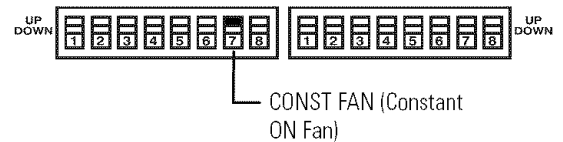

### Temperature Limiting

Temperature limiting can reduce energy costs by limiting the lowest temperature that can be set for cooling and the highest temperature that can be set for heating. Temperature limiting is controlled by the second six auxiliary switches.

The first three switches are used to select the cooling limits, and the remaining three switches are used to control the heating limits. This feature is not available with the Remote Thermostat—Class 2.

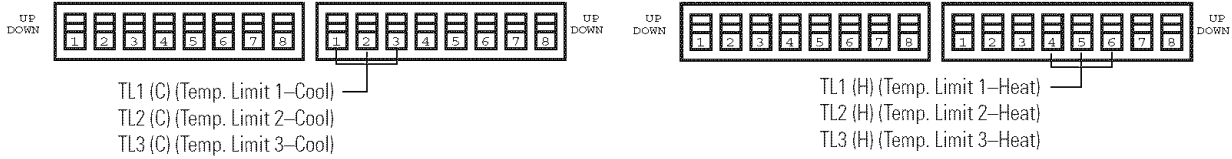

Temperature limiting during COOL mode (all temperatures shown in °F)			
UP	DOWN	Minimum	Maximum
NONE	1, 2, 3	60°	85°
1	2, 3	64°	85°
1, 2	3	66°	85°
2	1, 3	68°	85°
2, 3	1	70°	85°
1, 2, 3	NONE	72°	85°
1, 3	2	74°	85°
3	1, 2	76°	85°

Temperature limiting during HEAT mode (all temperatures shown in °F)			
UP	DOWN	Minimum	Maximum
NONE	4, 5, 6	60°	85°
4	5, 6	60°	80°
4, 5	6	60°	78°
5	4, 6	60°	76°
5, 6	4	60°	74°
4, 5, 6	NONE	60°	72°
4, 6	5	60°	70°
6	4, 5	60°	65°

### Heat Sentinel

When this switch is enabled (**UP**), it turns ON the heat sentinel protection feature. With the switch disabled (**DOWN**), the heat sentinel is de-activated. This feature automatically provides cooling without user interface. This helps to prevent an excessively hot room by turning the air conditioner ON at 85°F and OFF at 80°F.

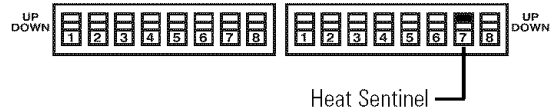

### Heat Boost (AZ3800 only)

When this switch is enabled (**UP**) and outdoor temperatures are between 20°F and 46°F, heat pump only operation is locked out. This setting is used to provide supplementary heat to the heat pump operation in conditions where the heat pump only operation is not sufficient to maintain a consistent, comfortable room temperature.

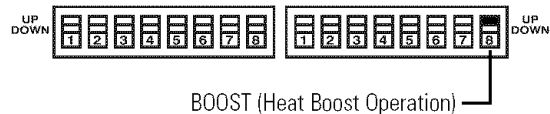

**NOTE:** This is an auxiliary switch for AZ2800 models and must remain in the (**DOWN**) position.

## Auxiliary controls on your Zoneline.

### Auxiliary Controls—Terminal Connections

The auxiliary controls are located behind the room cabinet beneath the access cover.

- 1 Remove the room cabinet. See the *To Remove the Room Cabinet* section.
- 2 Remove the screw from the access cover.
- 3 To make wiring connections, insert the wires into the bottom of the terminals and tighten screws securely.
- 4 After all desired connections have been made, replace the access cover and room cabinet.

The owner is responsible for making all connections and setting the appropriate dip switches.

### ⚠ CAUTION:

Improper wiring may damage the Zoneline electronics. No common busing is permitted. Damage or erratic operation may result. A separate wire pair must be run from each separate controlling switch to each individual Zoneline.

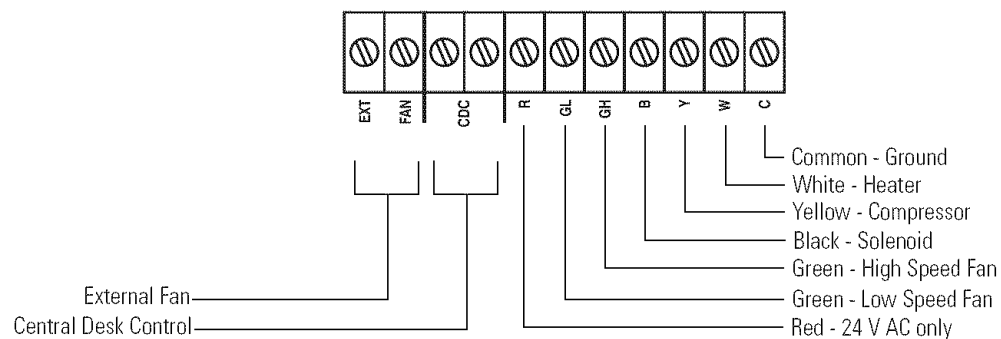



### External Fan (Obtained locally)

When connected, an auxiliary or external fan can be controlled with the indoor fan motor on the Zoneline. Connections provide 24 V AC to energize a remote relay, turning on the external fan.

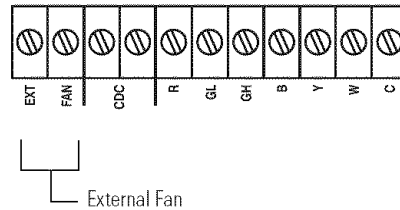

### Central Desk Control

When connected, the unit can be turned ON or OFF with a switch located at the Central Control Panel. A separate wire pair must be run from each separate controlling switch to each individual Zoneline.

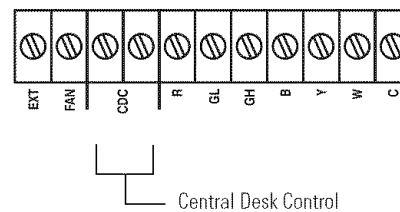

### Remote Thermostat

When connected, the unit will be controlled by a remote thermostat.

**NOTE:** The number 4 dip switch must be in the enabled (**UP**) position to activate the remote thermostat. (See the installation instructions supplied with the remote thermostat).

### IMPORTANT:

The Zoneline thermostat connections provide 24 V AC only.

If using a digital/electronic wall thermostat, you must set it to the 24 V AC setting. See the Installation Instructions for the wall thermostat.

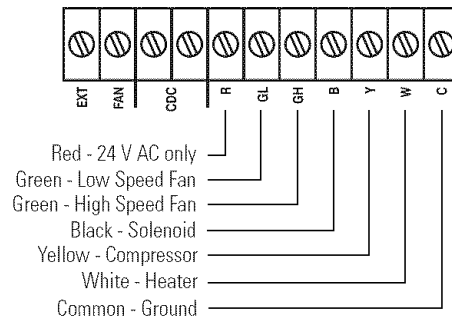

### CAUTION:

Damage to a wall thermostat or to the Zoneline electronics can result from improper connections. Special care must be used in connecting the wires. No line voltage connections should be made to any circuit. Isolate all wires in building from line voltage.

## Care and cleaning.

### Room Cabinet and Case

Turn the Zoneline off and disconnect the power supply.

To clean, use water and a mild detergent. Do not use bleach or abrasives. Some commercial cleaners may damage the plastic parts.

### Outdoor Coils

The coils on the outdoor side of the Zoneline should be checked regularly. If they are clogged with dirt or soot, they may be professionally steam cleaned, a service available through your GE service outlet. You will need to remove the unit to inspect the coils because the dirt buildup occurs on the inside.

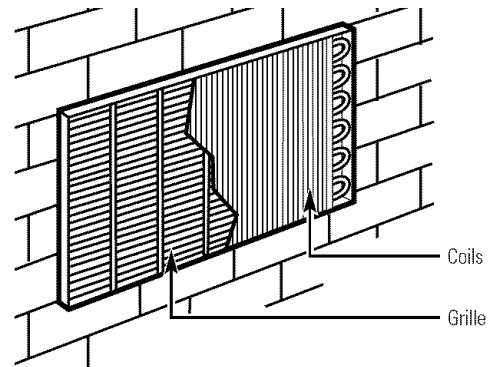

*Clean the outside coils regularly.*

### Base Pan

In some installations, dirt or other debris may be blown into the unit from the outside and settle in the base pan (the bottom of the unit).

In some areas of the United States, a “gel-like” or “slime-like” substance may be seen in the base pan. Check it periodically and clean, if necessary.

### Ventilation Filter

*If the vent door is open, clean the vent filter twice a year or as required.*

*Turn the Zoneline off before cleaning.*

#### **To remove the vent filter:**

- Remove the room cabinet. See the *To Remove the Room Cabinet* section.
- Remove the four screws securing the unit flanges to the case.
- Slide the unit from the wall case.
- Grasp the vent filter tab and pull the filter out by sliding it to the right.

#### **To clean the vent filter:**

- Run water through the filter from the back side.
- Dry thoroughly before replacing.

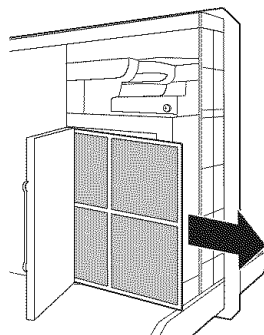

To maintain optimum performance, clean the filters at least every 30 days.

## Air Filters

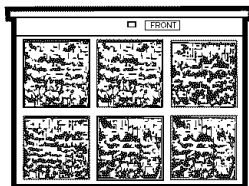

Dirty filter—Needs cleaning

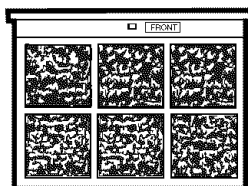

Clogged filter—Greatly reduces cooling, heating and airflow.

### Turn the Zoneline off before cleaning.

The most important thing you can do to maintain the Zoneline is to clean the filter at least every 30 days. Clogged filters reduce cooling, heating and air flow.

### Keeping these filters clean will:

- Decrease cost of operation.
- Save energy.
- Prevent clogged heat exchanger coils.
- Reduce the risk of premature component failure.

### To clean the air filters:

- Vacuum off the heavy soil.
- Run water through the filters from the back side.
- Dry thoroughly before replacing.

**NOTE:** The air filters are interchangeable and will fit in either the right or left side.

### To remove the air filters:

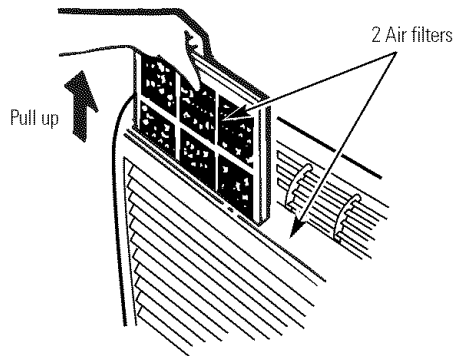

### To replace the air filters:

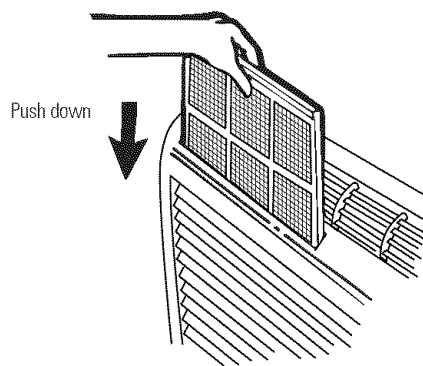

**CAUTION:** Do not operate the Zoneline without the filters in place. If a filter becomes torn or damaged, it should be replaced immediately.

Operating without the filters in place or with damaged filters will allow dirt and dust to reach the indoor coil and reduce the cooling, heating, airflow and efficiency of the unit.

Replacement filters are available from your salesperson, GE dealer, GE Service and Parts Center or authorized Customer Care® servicers.

# Installation Instructions

# Zoneline Air Conditioners

Questions? Call 800.GE.CARES (800.432.2737) or Visit our Website at: [ge.com](http://ge.com)

## BEFORE YOU BEGIN

Read these instructions completely and carefully.

- **IMPORTANT** — Save these instructions for local inspector's use.
- **IMPORTANT** — Observe all governing codes and ordinances.
- **Note to Installer** — Be sure to leave these instructions with the owner.
- **Note to Owner** — Keep these instructions for future reference.
- Proper installation is the responsibility of the installer.
- Product failure due to improper installation is not covered under the Warranty.

## TOOLS YOU WILL NEED



Phillips screwdriver

## IMPORTANT ELECTRICAL SAFETY—READ CAREFULLY

### ⚠ CAUTION:

- Follow the National Electrical Code (NEC) or local codes and ordinances.
- For personal safety, this Zoneline must be properly grounded.
- Protective devices (fuses or circuit breakers) acceptable for Zoneline installations are specified on the nameplate of each unit.
- Do not use an extension cord with this unit.
- Aluminum building wiring may present special problems—consult a qualified electrician.
- When the unit is in the OFF position, there is still voltage to the electrical controls.
- Disconnect the power to the unit before servicing by:
  - 1 Removing the power cord (if it has one) from the wall receptacle.OR
  - 2 Removing the branch circuit fuses or turning the circuit breakers off at the panel.

## ZONELINE COMPONENTS

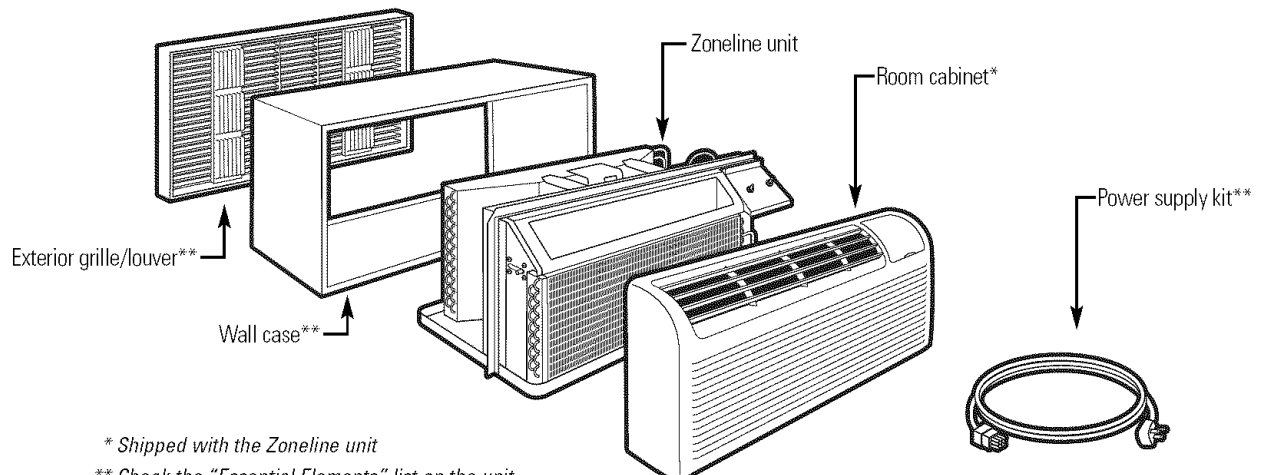

\* Shipped with the Zoneline unit

\*\* Check the "Essential Elements" list on the unit

# Installation Instructions

## REPLACING AN EXISTING UNIT?

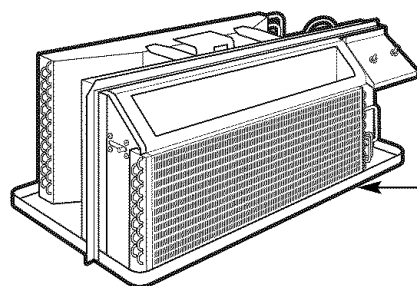

Check the "Essential Elements" label for important information.

### Use the correct wall case

This unit is designed to be installed in a GE plastic or insulated metal wall case. This minimizes condensation from forming on the room side of the case.

If the current wall case is not insulated, you can reduce the possibility of condensation forming by installing insulation kit RAK901L, available where you purchased the unit.

**NOTE:** There are several extra holes in the unit side flanges for installation in wall cases other than GE. To avoid damaging the flange insulation, the installer should use an awl or other sharp tool to puncture the insulation in the appropriate holes before installing the attachment screws.

### Use the correct outdoor grille

You should use the outdoor grilles shown on the "Essential Elements" label on the top of the unit.

- If an existing grille is not replaced, capacity and efficiency will be reduced and the unit may fail to operate properly or fail prematurely. A deflector kit, RAK40, may be used with grilles that were not designed for your new GE Zonelines. The RAK40 contains air deflectors and gaskets that mount to the unit to direct the hot exhaust air away from the air intake to allow the unit to function properly. The grille must have a 65% minimum free area.
- Any vertical deflectors in the existing rear grille should be removed to decrease condenser air recirculation that can cause the unit to "short-cycle" and lead to premature component failure.

### Use the correct power cord

Local codes may require the use of arc fault or leakage current detection devices on 230/208 volt installations.

### Replacing a ducted unit

#### New ducted installation:

If this unit is to be installed in a new ducted application using a duct adapter kit, the kit must be installed before the unit is placed in the wall case. The installation instructions are packed with the kit.

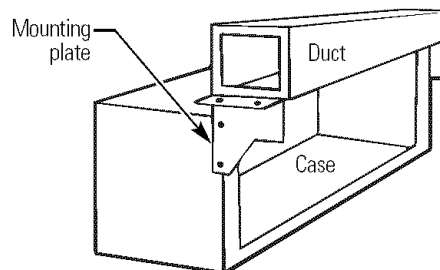

#### Existing ducted installation:

Replacement of an existing ducted unit may require different components. Request this information from your sales representative.

- **Replacing 230/208 volt units:**  
See page 14.
- **Replacing 265 volt units:**  
See pages 15 and 16.

# Installation Instructions

## 230/208 VOLT ELECTRICAL CONNECTION OPTIONS

### HOW TO CONNECT

- 1 Remove the room cabinet.
- 2 Connect to electrical power.
- 3 Review the following steps for applicable supply voltages.
- 4 Reinstall the room cabinet.

Power cords may include an arc fault interruption or a leakage current detection interruption device. A test and reset button is provided on the plug case or the inline case. The device should be tested on a periodic basis by first pressing the TEST button and then the RESET button. If the TEST button does not trip or if the RESET button will not stay engaged, discontinue use of the Zoneline and contact a qualified service technician.

### POWER CORD CONNECTION

A power supply kit must be used to supply power to the Zoneline unit. The appropriate kit is determined by the voltage, the means of electrical connection and the amperage of the branch circuit.

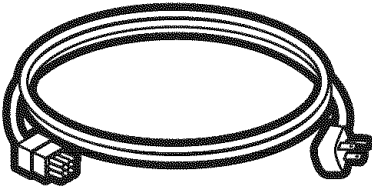

Power supply kit

Connections of 208 or 230 volt circuits may be with a power supply kit or a junction box kit.

All wiring, including installation of the receptacle, must be in accordance with the NEC and local codes, ordinances and regulations. Local codes may require the use of an arc fault or leakage current detection device on the power cord. Be sure to select the correct cord for your installation.



**Tandem**  
15 Amp.



**Perpendicular**  
20 Amp.



**Large Tandem**  
30 Amp.

230/208 volt receptacle configuration.

Branch Circuit and Unit Amperage Rating	Proper GE Power Cord with LCDI Device
15	RAK3153
20	RAK3203
30	RAK3303*

\*Not approved for use on 7000 BTU models.

### ELECTRICAL SUBBASE CONNECTION

230/208 volt models may be installed using one of the following electrical subbases:

Branch Circuit and Unit Amperage Rating	Proper GE Subbase Kit
15	RAK204D15P
20	RAK204D20P
30	RAK204D30P*

\*Not approved for use on 7000 BTU models.

Electrical subbases provide an enclosure for direct connection or enclosed receptacles. The subbase kit includes the power cord.

The instructions provided with the selected subbase kit must be carefully followed. It is the responsibility of the installer to ensure the connection of components is done in accordance with these instructions and all electrical codes.

### DIRECT CONNECTION

Order the following Kit for 230/208 volt direct connection as required:

Branch Circuit and Unit Amperage Rating	Power Supply Accessory	Power Supply Kit
15	RAK4002A	RAK4157
20	RAK4002A	RAK4207
30	RAK4002A	RAK4307

Skip to the "MAKE ELECTRICAL CONNECTION TO THE UNIT" section.

# Installation Instructions

## 265 VOLT ELECTRICAL CONNECTION OPTIONS

### **⚠ WARNING:**

Connection of this 265 V AC product to a branch circuit **MUST** be done by direct connection in accordance with the National Electrical Code. Plugging this unit into a building mounted exposed receptacle is not permitted by code.

These models must be installed using the appropriate GE power supply kit for the branch circuit amperage and the electrical resistance heater wattage desired. Use the POWER CONNECTION CHART on page 17 to determine the correct kit required. One of the following installation methods (**A** or **B**) must be used.

### **A. FOR SUBBASE INSTALLATION**

Electrical subbase kits are available to provide a flexible enclosure for direct connection.

<b><i>Branch Circuit and Unit Amperage Rating</i></b>	<b><i>Proper GE Subbase Kit</i></b>	<b><i>Power Supply Kit</i></b>
15	RAK204E15	RAK5172
20	RAK204E20	RAK5202
30	RAK204E30	RAK5302

The instructions provided with the selected subbase kit must be carefully followed. It is the responsibility of the installer to ensure the connection of components is done in accordance with these instructions and all electrical codes.

### **B. FOR DIRECT CONNECT INSTALLATION**

If an electrical subbase is not used, direct connection to branch circuit wiring inside the provided junction box must be done in accordance with the following steps.

Order the following Kit for 265 volt direct connection as required:

<b><i>Branch Circuit and Unit Amperage Rating</i></b>	<b><i>Power Supply Kit</i></b>
15	RAK5157
20	RAK5207
30	RAK5307

Proceed to the "MAKE ELECTRICAL CONNECTION TO THE UNIT" section.

# Installation Instructions

## MAKE ELECTRICAL CONNECTION TO THE UNIT

### 1 REMOVE JUNCTION BOX

- 1 Remove the junction box cover by removing the front two screws.
- 2 Remove the junction box by removing the top and bottom rear screws. Note how the tabs on the lower left side of the junction box serve to hold the side in place. This will help when the box is being reinstalled.

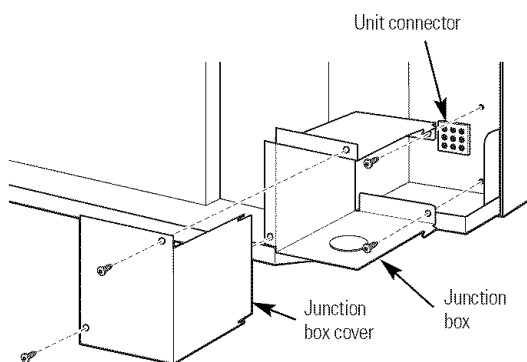

### 2 CONNECT THE CORDSET

Plug the connector, provided in the Direct Connect Kit, fully into place in the unit mating connector. Be sure the locking tabs at the sides are engaged.

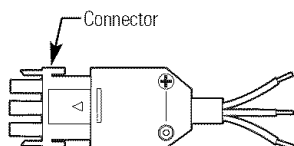

**NOTE:** Order Kit RAK4002CW to enable a quick disconnect inside the junction box.

### 3 ATTACH CONDUIT

- 1 Use the round knockout at the bottom of the junction box to attach conduit coming from the branch circuit. Remove the knockout, attach the conduit and bring wires into the junction box. Leave 6" of wire free at the end of the conduit to allow connections to be made.

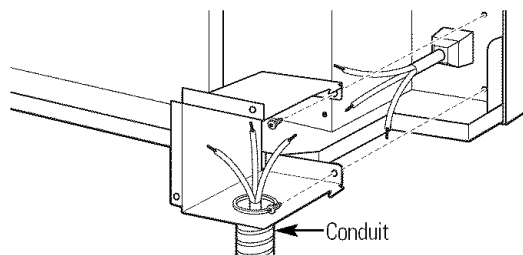

- 2 If a fuse and fuseholder are to be used, the knockout at the top of the box is for mounting a Buss Fuseholder. Be sure the fuse and fuseholder are of the same rating as the branch circuit. Leadwires at the fuse can be either soldered in place or attached using UL-listed 1/4" female (receptacle) crimp connectors.

### 4 REINSTALL JUNCTION BOX

- Reinstall the junction box by engaging the left tabs on the lower right face of the unit, aligning the screw holes at the top and bottom and driving the two screws until secure. Be sure that all wire leads are inside the box and not pinched between the box and the unit. The green insulated ground wire from the unit **MUST** be connected to the branch circuit ground wire.

Make all wire connections by using appropriate UL-listed electrical connectors and techniques (black to black, white to white and green to green).

### 5 REINSTALL JUNCTION BOX COVER

- 1 Carefully tuck all wires and connections back inside the junction box. Be sure there are no loose connections or stray uninsulated wires exposed.
- 2 Place the junction box cover in place. Replace the two screws removed earlier and tighten securely.

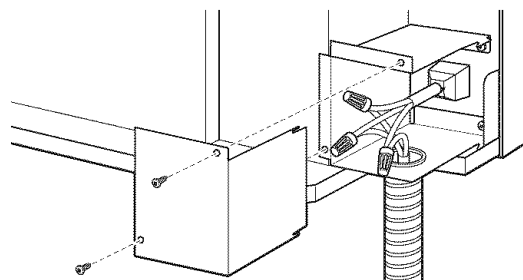



# Installation Instructions

## POWER CONNECTION CHART

### Power Cord Connections

230/208 Volt Power Supply Kits with Current Leakage Detection Device	Wall Plug Configuration	Circuit Protective Device	Heater Wattage @ 230/208 Volts
RAK3153	Tandem	15 Amp Time-Delay Fuse or Breaker	2.55/2.09 KW
RAK3203	Perpendicular	20 Amp Time-Delay Fuse or Breaker	3.45/2.82 KW
RAK3303*	Large Tandem	30 Amp Time-Delay Fuse or Breaker	5.00/4.10 KW

### Direct Connections

230/208 Volt Power Supply Kits	Heater Wattage @ 230/208 Volts	Circuit Protective Device
RAK4157	2.55 KW/2.09 KW	15 Amp Time-Delay Fuse or Breaker
RAK4207	3.45 KW/2.82 KW	20 Amp Time-Delay Fuse or Breaker
RAK4307	5.00 KW/4.10 KW	30 Amp Time-Delay Fuse or Breaker

265 Volt Power Supply Kits	Heater Wattage @ 265 Volts	Circuit Protective Device
RAK5172	2.55 KW	15 Amp Time-Delay Fuse or Breaker
RAK5202	3.45 KW	20 Amp Time-Delay Fuse or Breaker
RAK5302*	5.00 KW	30 Amp Time-Delay Fuse or Breaker

\* Not approved for use on 7000 BTUH units.

# Installation Instructions

## INSTALLING THE ZONELINE

### 1 INSTALL THE WALL CASE AND EXTERIOR GRILLE

The RAB71 series or RAB77 wall case must be properly installed per instructions packed with the case.

- Remove the corrugated stiffener and the outdoor protective panel. Use the slit in the outdoor panel as a handhold and push out.

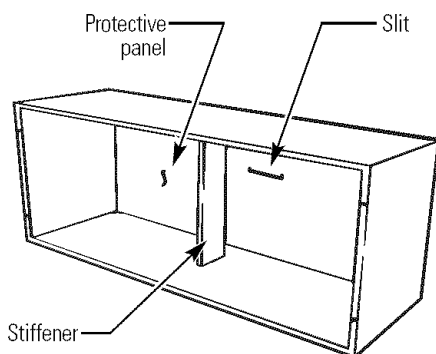

- Install the exterior grille from the room side following instructions packed with the grille.

#### Insulated Wall Case

This unit is designed to be installed in a GE plastic or an insulated steel wall case. This minimizes condensation from forming on the room side of the case.

The RAB71 series wall cases are insulated. Insulation kit RAK901L is available for use with RAB77 or existing uninsulated wall cases when needed.

**NOTE:** For installation with a subbase or duct adapter, see the instructions packed with those kits.

### 2 PREPARE THE UNIT

- Carefully remove shipping tape and foam shipping blocks from the room cabinet, compressor and vent door. There may be multiple blocks and pieces of shipping tape that need to be removed.

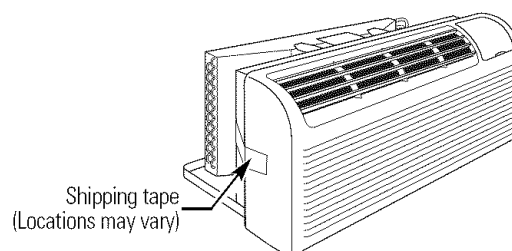

- Remove the room cabinet by pulling it out at the bottom to release it (1), then lift it up to clear the rail along the unit top (2).

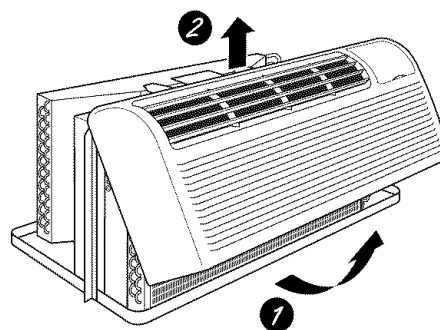

- If vent door is to be operational, remove shipping screws from the front side of the vent door, if present.

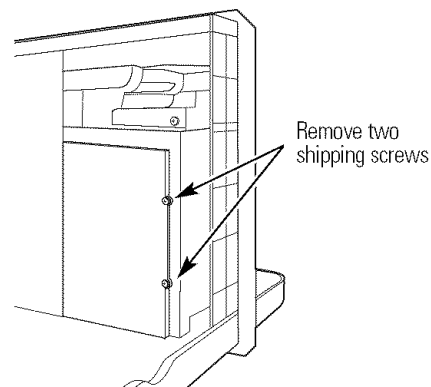

# Installation Instructions

## 3 INSTALL THE UNIT INTO THE WALL CASE

Slide the unit into the wall case and secure with four screws through the unit flange holes.

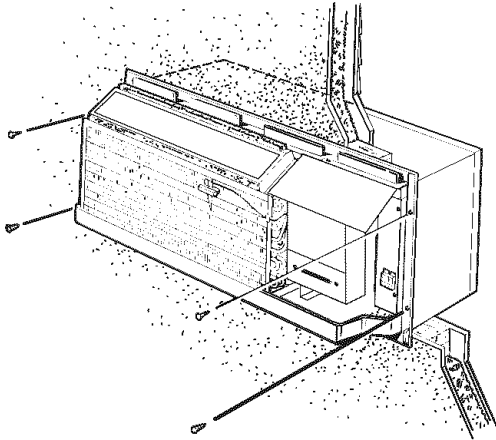

**NOTE:** There are several extra holes in the unit side flanges for installation in wall cases other than GE. To avoid damaging the flange insulation, the installer should use an awl or other sharp tool to puncture the insulation in the appropriate holes before installing the attachment screws.

## 4 REPLACE THE ROOM CABINET

Reinstall the room cabinet by hooking the top over the rail along the unit top (1), then pushing it in at the bottom (2).

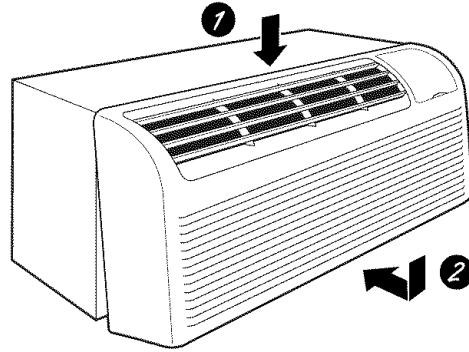

# Installation Instructions

## OPTIONAL—DRAIN KIT INSTALLATION

Dry Air 25 Series models are designed to improve dehumidification by 25%. Since more moisture will be removed from the air, there is a greater possibility that water will drip from the wall case than with a standard unit. To prevent this water from dripping onto external building walls, we recommend the use of RAD10 Drain Kit.

### External Drain

See the Installation Instructions in the RAD10 kit.

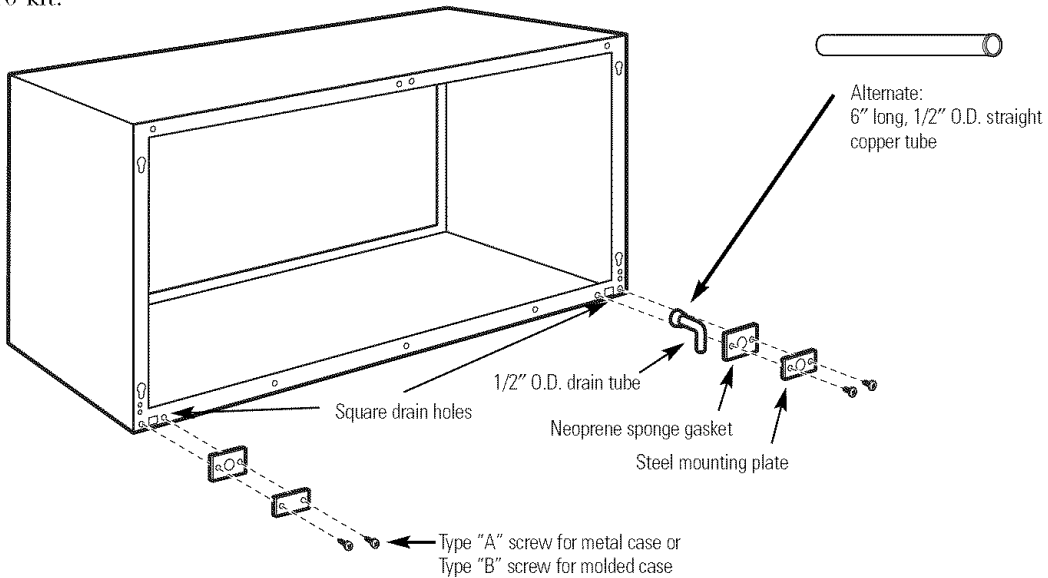

### Internal Drain

See the Installation Instructions in the RAD10 kit.

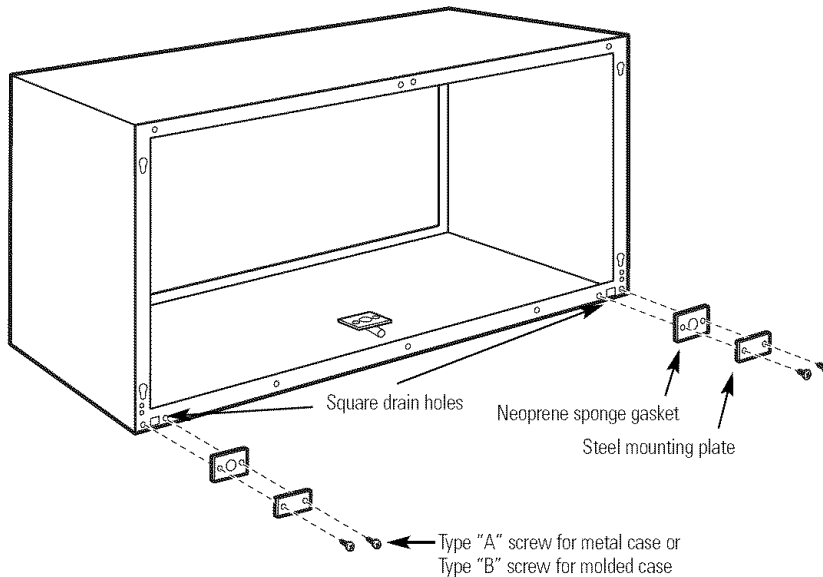

# Before you call for service...

ge.com



**Troubleshooting Tips**  
Save time and money! Review the charts on the following pages first and you may not need to call for service.

<b>Problem</b>	<b>Possible Causes</b>	<b>What To Do</b>
<b>Zoneline does not start</b>	The unit is unplugged.	<ul style="list-style-type: none"> <li>Make sure the Zoneline plug is pushed completely into the outlet.</li> </ul>
	The power cord is not firmly attached.	<ul style="list-style-type: none"> <li>Remove the room cabinet and make sure that the yellow connector on the end of the power cord is firmly engaged.</li> </ul>
	The fuse is blown/circuit breaker is tripped.	<ul style="list-style-type: none"> <li>Check the house fuse/circuit breaker box and replace the fuse or reset the breaker.</li> </ul>
	The unit is waiting for the compressor overload protector to reset.	<ul style="list-style-type: none"> <li>This is normal. The Zoneline will start again after it resets.</li> </ul>
	Power failure.	<ul style="list-style-type: none"> <li>If power failure occurs, set the mode control to <b>STOP</b>. When power is restored, set the mode control to the desired setting.</li> <li>There is a protective time delay (up to 3 minutes) to prevent tripping of the compressor overload. For this reason, the unit may not start normal heating or cooling for 3 minutes after it is turned back on.</li> </ul>
The current interrupter device is tripped.	<ul style="list-style-type: none"> <li>Press the <b>RESET</b> button located on the power cord plug or the box near the plug.</li> <li>If the <b>RESET</b> button will not stay engaged, discontinue use of the Zoneline and contact a qualified service technician.</li> </ul>	
<b>Zoneline does not cool or heat as it should</b>	Indoor airflow is restricted.	<ul style="list-style-type: none"> <li>Make sure there are no curtains, blinds or furniture blocking the front of the Zoneline.</li> </ul>
	Outdoor airflow is restricted or recirculated.	<ul style="list-style-type: none"> <li>Make sure the rear grille is not restricted. This can cause the unit to cycle off due to the compressor overload protector.</li> <li>Outdoor grille must have a minimum of 65% free area. Non-GE grilles may be too restrictive for proper performance. Consult your salesperson for assistance.</li> </ul>
	The temp control may not be set properly.	<ul style="list-style-type: none"> <li>Turn the control to a lower or higher setting.</li> <li><b>NOTE:</b> The temperature limiter may be limiting the temperature range.</li> </ul>
	The air filter is dirty.	<ul style="list-style-type: none"> <li>Clean the filter at least every 30 days. See the <i>Operating Instructions</i> section.</li> </ul>
	The room may have been hot or cold.	<ul style="list-style-type: none"> <li>When the Zoneline is first turned on you need to allow time for the room to cool down or warm up.</li> </ul>
	Outdoor air is entering the room.	<ul style="list-style-type: none"> <li>Set the vent control to the closed position.</li> </ul>
<b>Burning odor at the start of heating operation</b>	Dust is on the surface of the heating element.	<ul style="list-style-type: none"> <li>This can cause a "burning" odor at the beginning of the heating operation. This odor should quickly fade.</li> </ul>

Safety Instructions

Operating Instructions

Care and Cleaning

Troubleshooting Tips

Consumer Support

## Before you call for service...

<i>Problem</i>	<i>Possible Causes</i>	<i>What To Do</i>
<i>The air is not always cool or hot during operation</i>	The heat pump is not producing hot air.	<ul style="list-style-type: none"> <li>This is normal. The heat pump will produce warm air but not as hot as air produced when the higher-cost electric heat is used.</li> </ul>
	The fan switches may be set at continuous fan.	<ul style="list-style-type: none"> <li>This causes the fan to blow room temperature air even when the compressor or heater cycles off. The continuous air movement provides better overall temperature control in the cool mode.</li> <li>There is one switch for cooling and one switch for heating.</li> </ul>
<i>The air does not feel warm enough during heating operation</i>	The heat pump alone produces air that feels cooler than desired.	<ul style="list-style-type: none"> <li>Use the Electric Heat Option. This turns off the heat pump and warms with electric heat only. <b>NOTE:</b> Use of this option will result in increased energy consumption.</li> </ul>
<i>The unit is not blowing out air</i>	The fan dip switch may be set to <b>CYCLE</b> .	<ul style="list-style-type: none"> <li>See the <i>Auxiliary Controls</i> section.</li> </ul>
<i>The electric heating feature does not work</i>	The power cord is not firmly attached.	<ul style="list-style-type: none"> <li>Remove the room cabinet and make sure that the yellow connector on the end of the power cord is firmly engaged.</li> </ul>

**Normal Operating Sounds**



You may hear a pinging noise caused by water being picked up and thrown against the condenser on rainy days or when the humidity is high. This design feature helps remove moisture and improve efficiency.

**"CLICK"**

You may hear relays click when the controls cycle on and off or are adjusted to change the room temperature.



Water will collect in the base pan during high humidity or on rainy days. The water may overflow and drip from the outdoor side of the unit.



The indoor fan runs continuously when the unit is operating in the cooling mode, unless the fan switch behind the room cabinet is set at fan cycle (up). This will cause the fan to cycle on and off with the compressor. You may also hear a fan noise stop and start.

**3-Minute Delay**

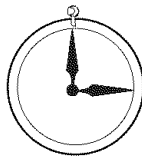

You may notice a few minutes delay in starting if you try to restart the Zoneline too soon after turning it off or if you adjust the thermostat right after the compressor has shut off. This is due to a built-in restart protector for the compressor that causes a 3-minute delay.

**SILENCE**

During the defrost cycle, both indoor and outdoor fans stop and the compressor will operate in the cooling mode to remove frost from the outdoor coil. After defrost, the unit will restart in electric heat to quickly warm the room to the desired comfort level.

**COMPRESSOR PROTECTION**

To protect the compressor and prevent short cycling, the unit is designed to run for a minimum of 3 minutes after the compressor starts at any thermostat setting.

Safety Instructions

Operating Instructions

Care and Cleaning

Troubleshooting Tips

Consumer Support

<i>Consumer Support</i>	<i>Troubleshooting Tips</i>	<i>Care and Cleaning</i>	<i>Operating Instructions</i>	<i>Safety Instructions</i>
-------------------------	-----------------------------	--------------------------	-------------------------------	----------------------------

**Notes.**

---





Please place in envelope and mail to:

***General Electric Company***  
**Warranty Registration Department**  
**P.O. Box 32150**  
**Louisville, KY 40232-2150**

# Consumer Product Ownership Registration

Dear Customer:

Thank you for purchasing our product and thank you for placing your confidence in us. We are proud to have you as a customer!

Follow these three steps to protect your new appliance investment:

# 1

Complete and mail your Consumer Product Ownership Registration today. Have the peace of mind of knowing we can contact you in the unlikely event of a safety modification.

# 2

After mailing the registration below, store this document in a safe place. It contains information you will need should you require service. Our service number is 800.GE.CARES (800.432.2737).

# 3

Read your Owner's Manual carefully. It will help you operate your new appliance properly.

Model Number

Serial Number

**Important: If you did not get a registration card with your product, detach and return the form below to ensure that your product is registered, or register online at ge.com.**

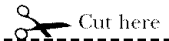

## Consumer Product Ownership Registration



Model Number

Serial Number

Mr.  Ms.  Mrs.  Miss

First Name

Last Name

Street Address

Apt. #

E-mail Address\*

City  State  Zip Code

Date Placed In Use Month  Day  Year  Phone Number --



**GE Consumer & Industrial Appliances**  
General Electric Company  
Louisville, KY 40225  
ge.com

\* Please provide your e-mail address to receive, via e-mail, discounts, special offers and other important communications from GE Appliances (GEA).

Check here if you do not want to receive communications from GEA's carefully selected partners.

**FAILURE TO COMPLETE AND RETURN THIS CARD DOES NOT DIMINISH YOUR WARRANTY RIGHTS.**

For more information about GEA's privacy and data usage policy, go to ge.com and click on "Privacy Policy" or call 800.626.2224.

# Zoneline Warranty.



All warranty service provided by our Factory Service Centers, or an authorized Customer Care<sup>®</sup> technician. To schedule service, on-line, 24 hours a day, visit us at [ge.com](http://ge.com), or call 800.GE.CARES (800.432.2737). For service in Canada, call 1.800.361.3400. Please have serial number and model number available when calling for service.

Staple your receipt here. Proof of the original purchase date is needed to obtain service under the warranty.

For The Period Of:	GE Will Replace:
<b>One Year</b> From the date of the original purchase	<b>Any part</b> of the Zoneline which fails due to a defect in materials or workmanship. During this <b>limited one-year warranty</b> , GE will also provide, <b>free of charge</b> , all labor and related service to replace the defective part.
<b>Five Years</b> From the date of the original purchase	<b>Any part of the sealed refrigerating system</b> (the compressor, condenser, evaporator and all connecting tubing) which fails due to a defect in materials or workmanship. During this <b>four-year limited additional warranty</b> , GE will also provide, <b>free of charge</b> , all labor and related service to replace the defective part.
<b>Five Years</b> From the date of the original purchase	For the <b>second through the fifth year</b> from the date of original purchase, GE will replace <b>certain parts</b> that fail due to a defect in materials or workmanship. Parts covered are fan motors, switches, thermostats, heater, heater protectors, compressor overload, solenoids, circuit boards, auxiliary controls, thermistors, frost controls, ICR pump, capacitors, varistors and indoor blower bearing. During this <b>four-year limited additional warranty</b> , you will be responsible for any labor or on-site service costs.

## What GE Will Not Cover:

- Service trips to your site to teach you how to use the product.
- Improper installation, delivery or maintenance.  
If you have an installation problem, or if the air conditioner is of improper cooling capacity for the intended use, contact your dealer or installer. You are responsible for providing adequate electrical connecting facilities.
- In commercial locations, labor necessary to move the unit to a location where it is accessible for service by an individual technician.
- Failure or damage resulting from corrosion due to installation in an environment containing corrosive chemicals.
- Replacement of fuses or resetting of circuit breakers.
- Failure of the product resulting from modifications to the product or due to unreasonable use, including failure to provide reasonable and necessary maintenance.
- Failure or damage resulting from corrosion due to installation in a coastal environment, except for models treated with special factory-applied anti-corrosion protection as designated in the model number.
- Damage to product caused by improper power supply voltage, accident, fire, floods or acts of God.
- Incidental or consequential damage to personal property caused by possible defects with this air conditioner.
- Damage caused after delivery.
- Product not accessible to provide required service.

**EXCLUSION OF IMPLIED WARRANTIES**—Your sole and exclusive remedy is product repair as provided in this Limited Warranty. Any implied warranties, including the implied warranties of merchantability or fitness for a particular purpose, are limited to one year or the shortest period allowed by law.

This warranty is extended to the original purchaser and any succeeding owner for products purchased for use within the USA and Canada. If the product is located in an area where service by a GE Authorized Servicer is not available, you may be responsible for a trip charge or you may be required to bring the product to an Authorized GE Service location for service. In Alaska, the warranty excludes the cost of shipping or service calls to your site.

Some states or provinces do not allow the exclusion or limitation of incidental or consequential damages. This warranty gives you specific legal rights, and you may also have other rights which vary from state to state or province to province. To know what your legal rights are, consult your local, state or provincial consumer affairs office or your state's Attorney General.

## Consumer Support.

---



### *GE Appliances Website*

***ge.com***

Have a question or need assistance with your appliance? Try the GE Appliances Website 24 hours a day, any day of the year! For greater convenience and faster service, you can now download Owner's Manuals, order parts or even schedule service on-line.

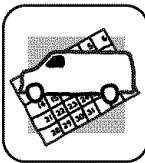

### *Schedule Service*

***ge.com***

Expert GE repair service is only one step away from your door. Get on-line and schedule your service at your convenience 24 hours any day of the year! Or call 800.GE.CARES (800.432.2737) during normal business hours.

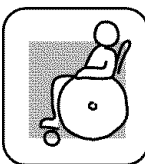

### *Real Life Design Studio*

***ge.com***

GE supports the Universal Design concept—products, services and environments that can be used by people of all ages, sizes and capabilities. We recognize the need to design for a wide range of physical and mental abilities and impairments. For details of GE's Universal Design applications, including kitchen design ideas for people with disabilities, check out our Website today. For the hearing impaired, please call 800.TDD.GEAC (800.833.4322).

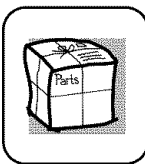

### *Parts and Accessories*

***ge.com***

Individuals qualified to service their own appliances can have parts or accessories sent directly to their homes (VISA, MasterCard and Discover cards are accepted). Order on-line today, 24 hours every day or by phone at 800.626.2002 during normal business hours.

***Instructions contained in this manual cover procedures to be performed by any user. Other servicing generally should be referred to qualified service personnel. Caution must be exercised, since improper servicing may cause unsafe operation.***



### *Contact Us*

***ge.com***

If you are not satisfied with the service you receive from GE, contact us on our Website with all the details including your phone number, or write to: General Manager, Customer Relations  
GE Appliances, Appliance Park  
Louisville, KY 40225



### *Register Your Appliance*

***ge.com***

**Register your new appliance on-line—at your convenience!** Timely product registration will allow for enhanced communication and prompt service under the terms of your warranty, should the need arise. You may also mail in the pre-printed registration card included in the packing material, or detach and use the form in this Owner's Manual.