

SONY®

3-085-733-12(1)

Digital Still Camera

Operating Instructions

Before operating the unit, please read this manual thoroughly, and retain it for future reference.

Owner's Record

The model and serial numbers are located on the bottom. Record the serial number in the space provided below. Refer to these numbers whenever you call upon your Sony dealer regarding this product.

Model No. DSC-T1

Serial No. _____

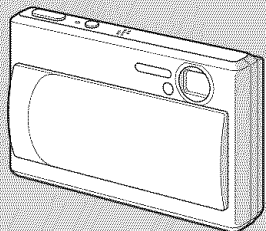

Cyber-shot
Digital Still Camera



MEMORY STICK™

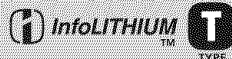

DSC-T1

Getting started _____

Shooting still images _____

Viewing still images _____

Deleting still images _____

Before advanced operations _____

Advanced still image shooting _____

Advanced still image viewing _____

Still image editing _____

Enjoying movies _____

Enjoying images on your computer _____

Troubleshooting _____

Additional information _____

Index _____

WARNING

To prevent fire or shock hazard, do not expose the unit to rain or moisture.

For the Customers in the U.S.A.

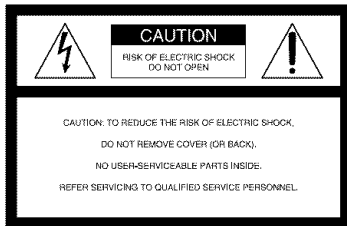

This symbol is intended to alert the user to the presence of uninsulated “dangerous voltage” within the product’s enclosure that may be of sufficient magnitude to constitute a risk of electric shock to persons.



This symbol is intended to alert the user to the presence of important operating and maintenance (servicing) instructions in the literature accompanying the appliance.

If you have any questions about this product, you may call:

Sony Customer Information Services Center
1-800-222-SONY (7669)

The number below is for the FCC related matters only.

Regulatory Information

Declaration of Conformity

Trade Name: SONY
Model No.: DSC-T1
Responsible Party: Sony Electronics Inc.
Address: 16450 W. Bernardo Dr,
San Diego, CA 92127
U.S.A.
Telephone No.: 858-942-2230

This device complies with Part 15 of the FCC Rules. Operation is subject to the following two conditions: (1) This device may not cause harmful interference, and (2) this device must accept any interference received, including interference that may cause undesired operation.

Note:

Model DSC-T1 is to be used with USB cradle Model UC-TA and AC Adaptor Model AC-LM5.

CAUTION

You are cautioned that any changes or modifications not expressly approved in this manual could void your authority to operate this equipment.

Note:

This equipment has been tested and found to comply with the limits for a Class B digital device, pursuant to Part 15 of the FCC Rules. These limits are designed to provide reasonable protection against harmful interference in a residential installation. This equipment generates, uses, and can radiate radio frequency energy and, if not installed and used in accordance with the instructions, may cause harmful interference to radio communications. However, there is no guarantee that interference will not occur in a particular installation. If this equipment does cause harmful interference to radio or television reception, which can be determined by turning the equipment off and on, the user is encouraged to try to correct the interference by one or more of the following measures:

- Reorient or relocate the receiving antenna.
- Increase the separation between the equipment and receiver.
- Connect the equipment into an outlet on a circuit different from that to which the receiver is connected.
- Consult the dealer or an experienced radio/TV technician for help.

The shielded interface cable must be used with the equipment in order to comply with the limits for a digital device pursuant to Subpart B of Part 15 of FCC Rules.

For the Customers in the U.S.A. and Canada

RECYCLING LITHIUM-ION BATTERIES

Lithium-Ion batteries are recyclable.

You can help preserve our environment by returning your used rechargeable batteries to the collection and recycling location nearest you.



For more information regarding recycling of rechargeable batteries, call toll free 1-800-822-8837, or visit <http://www.rbc.org/>

Caution: Do not handle damaged or leaking Lithium-Ion batteries.



CAUTION

TO PREVENT ELECTRIC SHOCK, MATCH WIDE BLADE OF PLUG TO WIDE SLOT, FULLY INSERT.

Never expose the battery pack to temperature above 60°C (140°F), such as in a car parked in the sun or under direct sunlight.

Notice for the customers in the United Kingdom

A moulded plug complying with BS 1363 is fitted to this equipment for your safety and convenience.

Should the fuse in the plug supplied need to be replaced, a fuse of the same rating as the supplied one and approved by ASTA or BSI to BS 1362, (i.e., marked with  or  mark) must be used.

If the plug supplied with this equipment has a detachable fuse cover, be sure to attach the fuse cover after you change the fuse. Never use the plug without the fuse cover. If you should lose the fuse cover, please contact your nearest Sony service station.

Attention for the Customers in Europe

This product has been tested and found compliant with the limits sets out in the EMC Directive for using connection cables shorter than 3 meters (9.8 feet).

Attention

The electromagnetic field at the specific frequencies may influence the picture and sound of this camera.

Notice

If static electricity or electromagnetism causes data transfer to discontinue midway (fail), restart the application or disconnect and connect the USB cable again.

“Memory Stick”



For the Customers in the U.S.A.

THIS DEVICE COMPLIES WITH PART 15 OF THE FCC RULES. OPERATION IS SUBJECT TO THE FOLLOWING TWO CONDITIONS:

- (1) THIS DEVICE MAY NOT CAUSE HARMFUL INTERFERENCE, AND
- (2) THIS DEVICE MUST ACCEPT ANY INTERFERENCE RECEIVED, INCLUDING INTERFERENCE THAT MAY CAUSE UNDESIRED OPERATION.

For the Customers in Canada

THIS CLASS B DIGITAL APPARATUS COMPLIES WITH CANADIAN ICES-003.

Notice

Certain countries and regions may regulate disposal of the battery used to power this product. Please consult with your local authority.

Before using your camera

Trial recording

Before you record one-time events, you may want to make a trial recording to make sure that the camera is working correctly.

No compensation for contents of the recording

Contents of the recording cannot be compensated for if recording or playback is not possible due to a malfunction of your camera or recording media, etc.

Back up recommendation

To avoid the potential risk of data loss, always copy (back up) data to a disk.

Notes on image data compatibility

- This camera conforms with the Design rule for Camera File system universal standard established by the JEITA (Japan Electronics and Information Technology Industries Association).
- Playback of images recorded with your camera on other equipment and playback of images recorded or edited with other equipment on your camera are not guaranteed.

Precaution on copyright

Television programs, films, video tapes, and other materials may be copyrighted. Unauthorized recording of such materials may be contrary to the provision of the copyright laws.

Do not shake or strike the camera

In addition to malfunctions and inability to record images, this may render the “Memory Stick Duo” unusable or image data breakdown, damage or loss may occur.

LCD screen, LCD finder (only models with an LCD finder) and lens

- The LCD screen and the LCD finder are manufactured using extremely high-precision technology so over 99.99% of the pixels are operational for effective use. However, there may be some tiny black points and/or bright points (white, red, blue or green in color) that constantly appear on the LCD screen and the LCD finder. These points are normal in the manufacturing process and do not affect the recording in any way.
- Be careful when placing the camera near a window or outdoors. Exposing the LCD screen, the finder or the lens to direct sunlight for long periods may cause malfunctions.
- Do not press the LCD screen hardy. The screen may be uneven and that may cause a malfunction.
- Do not press the lens portion hard, or it may cause the malfunction of the lens.
- Images may be trailed on the LCD screen in a cold location. This is not a malfunction.

Carl Zeiss lens

This camera is equipped with a Carl Zeiss lens which is capable of reproducing sharp images with excellent contrast.

The lens for this camera has been produced under a quality assurance system certified by Carl Zeiss in accordance with the quality standards of Carl Zeiss in Germany.

Clean the flash surface before use

The heat of flash emission may cause dirt on the flash surface to become discolored or to stick to the flash surface, resulting in insufficient light emission.

Do not get the camera wet

When taking pictures outdoors in the rain or under similar conditions, be careful not to get the camera wet. Water entering the inside of the camera may cause malfunctions which in some cases may not be repairable. If moisture condensation occurs, see page 108 and follow the instructions on how to remove it before using the camera.

Do not expose the camera to sand or dust

Using the camera in sandy or dusty locations may cause malfunction.

Do not aim the camera at the sun or other bright light

This may cause irrecoverable damage to your eyes. Or it may cause the malfunction of your camera.

Note on the camera locations

Do not use the camera near a location that generates strong radio wave or emits radiation. The camera may not be able to record or play back properly.

The pictures used in this manual

The photographs used as examples of pictures in this manual are reproduced images, and are not actual images shot using this camera.

Trademarks

- “Memory Stick Duo” and **MEMORY STICK DUO** are trademarks of Sony Corporation.
- “Memory Stick PRO Duo” and **MEMORY STICK PRO DUO** are trademarks of Sony Corporation.
- “MagicGate Memory Stick Duo” is a trademark of Sony Corporation.
- “Memory Stick,”  and “MagicGate Memory Stick” are trademarks of Sony Corporation.
- “Memory Stick PRO” and **MEMORY STICK PRO** are trademarks of Sony Corporation.
- “MagicGate” and **MAGICGATE** are trademarks of Sony Corporation.
- “InfoLITHIUM” is a trademark of Sony Corporation.
- Microsoft and Windows are registered trademarks of the U.S. Microsoft Corporation in the United States and other countries.
- Macintosh, Mac OS and QuickTime are trademarks or registered trademarks of Apple Computer, Inc.

- Pentium is a trademark or a registered trademark of Intel Corporation.
- In addition, system and product names used in this manual are, in general, trademarks or registered trademarks of their respective developers or manufacturers. However, the ™ or ® marks are not used in all cases in this manual.

Table of contents

Before using your camera	4
Identifying the parts	8
Camera	8
USB cradle	10
Connecting and disconnecting your camera	10

Getting started

Charging the battery pack	11
Using the AC Adaptor	15
Using your camera abroad	15
Turning on/off your camera	16
How to use the control button	16
Setting the date and time	17

Shooting still images

Inserting and removing a “Memory Stick Duo”	19
Setting the still image size	20
Image size	21
Basic still image shooting	
— Using auto adjustment mode	22
Checking the last image you shot	
— Quick Review	24
Indicators on the LCD screen during shooting	25
Using the zoom feature	25
Shooting close-ups	
— Macro	27
Using the self-timer	28

Selecting a flash mode	29
Inserting the date and time on a still image	30
Shooting according to scene conditions	
— Scene Selection	32

Viewing still images

Viewing images on the LCD screen of your camera	35
Viewing images on a TV screen	37

Deleting still images

Deleting images	39
Formatting a “Memory Stick Duo”	41

Before advanced operations

How to setup and operate your camera	43
Changing the menu settings	43
Changing the items on the Setup screen	44
Deciding the still image quality	44
Creating or selecting a folder	45
Creating a new folder	45
Changing the recording folder	46

Advanced still image shooting

Choosing an auto focus method	47
Choosing a focus range finder frame	
— AF range finder	47
Choosing a focus operation	
— AF Mode	48
Setting the distance to the subject	
— Focus preset	49
Adjusting the exposure	
— EV adjustment	50
Displaying a histogram	51
Selecting the metering mode	52
Shooting three images with the exposure shifted — Exposure Bracket	52
Adjusting color tones	
— White Balance	54
Adjusting the flash level	
— Flash Level	55
Shooting images continuously	
— Burst	55
Shooting in Multi Burst mode	
— Multi Burst	56
Shooting still images for e-mail	
— E-Mail	57
Shooting still images with audio files	
— Voice	58
Adding special effects	
— Picture Effect	58

Advanced still image viewing

Selecting the folder and playing back images	
— Folder	60
Enlarging a portion of a still image	61
Enlarging an image	
— Playback zoom	61
Recording an enlarged image	
— Trimming	62
Playing back successive images	
— Slide Show	62
Rotating still images	
— Rotate	63
Playing back images shot in Multi Burst mode	64
Playing back continuously	64
Playing back frame by frame	65

Still image editing

Protecting images	
— Protect	66
Changing image size	
— Resize	67
Choosing images to print	
— Print (DPOF) mark	68

Enjoying movies

Shooting movies	70
Viewing movies on the LCD screen	71
Deleting movies	72
Editing movies	73
Cutting movies	74
Deleting unnecessary portions of movies	74

Enjoying images on your computer

Copying images to your computer	
— For Windows users	75
Copying images to your computer	
— For Macintosh users	86

Troubleshooting

Troubleshooting	88
Warnings and messages	97
Self-diagnosis display	99

Additional information

Number of images that can be saved or shooting time	100
Menu items	102
Setup items	106
Precautions	108
On “Memory Stick”	109
On “InfoLITHIUM” battery pack	111
Specifications	112
The LCD screen	114

Index

Index	118
-------	-----

Identifying the parts

See the pages in parentheses for details of operation.

Camera

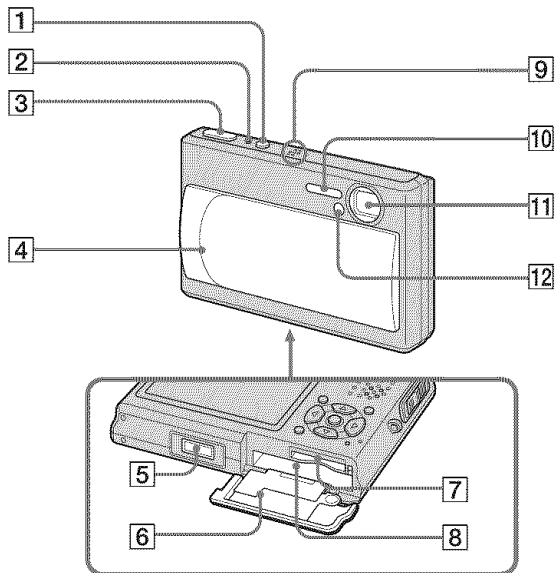

- 1 POWER button (16)
- 2 POWER lamp (16)
- 3 Shutter button (22)
- 4 Lens cover (16)
- 5 Multi connector (13, 15)
- 6 Battery/"Memory Stick Duo" cover
- 7 "Memory Stick Duo" insertion slot (19)
- 8 Battery insertion slot (11)
- 9 Microphone
- 10 Flash (29)
- 11 Lens
- 12 Self-timer lamp (28)/AF illuminator (30, 106)

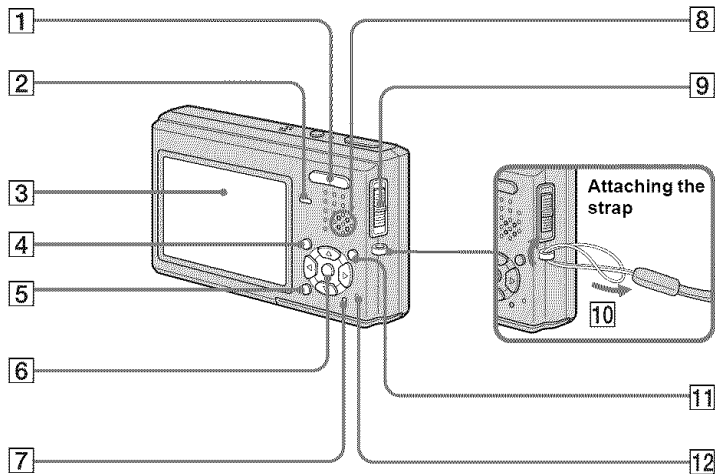

- 1** For shooting: Zoom (W/T) button (25)
For viewing: / (Playback zoom) button (61) / (Index) button (36)
- 2** / CHG lamp (orange) (12, 29)
- 3** LCD screen
- 4** MENU button (43, 102)
- 5** (Display/LCD backlight on/off) button (25)
- 6** Control button
Menu on: / / / / (16)
Menu off: / / / (29/28/24/27)
- 7** RESET button (88)
- 8** Speaker
- 9** Mode switch (17, 102)
 : To shoot movies
 : To shoot still images
 : To view or edit images
- 10** Hook for wrist strap
- 11** / (Image Size/Delete) button (20, 39)
- 12** Access lamp (19)

USB cradle

This is used when charging the battery pack or connecting the camera to a TV or a computer, etc.

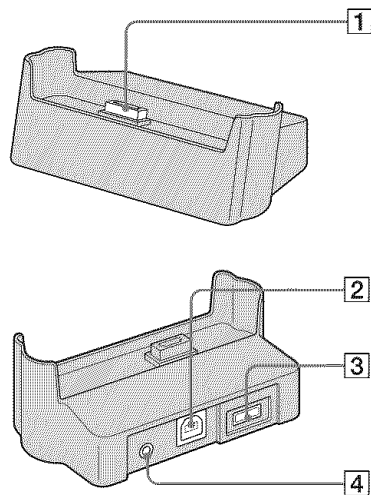

- 1 Camera connector
- 2 Ψ (USB) jack (79)
- 3 DC IN jack (11)
- 4 A/V OUT (MONO) jack (37)

Connecting and disconnecting your camera

How to connect

Connect the camera as illustrated.

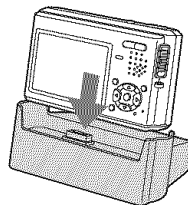



- Make sure the camera is securely connected to the USB cradle.

How to disconnect

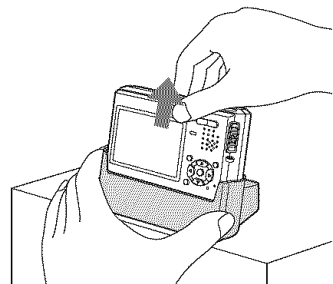
Grasp the camera and the USB cradle (supplied) as illustrated and disconnect the camera.



- Be sure to turn off the camera before you connect the camera to the USB cradle or disconnect the camera from the USB cradle.
- **Do not disconnect the camera from the USB cradle during the USB connection, as the data may be corrupted. To cancel the USB connection, see  on page 80 (Windows) or  on page 86 (Macintosh).**

Charging the battery pack

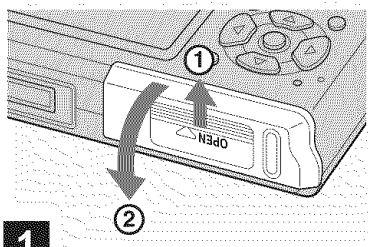

1

- ➔ Open the battery/"Memory Stick Duo" cover.

Slide the cover in the direction of the arrow.

- Be sure to turn off your camera when charging the battery pack (page 16).
- Your camera operates with the "InfoLITHIUM" NP-FT1 battery pack (T type) (supplied). You can use only T type battery pack (page 111).

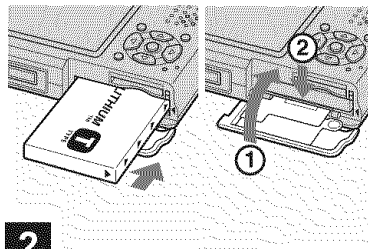

2

- ➔ Install the battery pack, then close the battery/"Memory Stick Duo" cover.

Make sure the battery pack is firmly inserted all the way, then close the cover.

Battery insertion slot

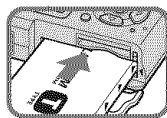

Insert the battery pack so that the ▲ marks on the side of the battery pack face the same direction as the ▲ mark on the battery insertion slot.

- Be careful not to drop the battery pack when installing it.

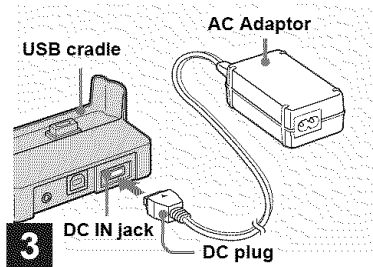

3

- ➔ Connect the AC Adaptor (supplied) to the DC IN jack of the USB cradle (supplied).

Connect the plug with the ▲ mark facing up.

- Do not short the DC plug of the AC Adaptor with a metallic object, as this may cause malfunction.

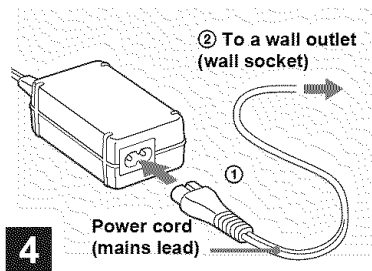

- 4** → Connect the power cord (mains lead) to the AC Adaptor and to a wall outlet (wall socket).

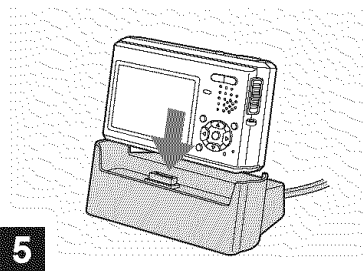

- 5** → Connect the camera to the USB cradle.

Connect the camera as illustrated. Make sure the camera is securely connected to the USB cradle.

The $\text{⚡}/\text{CHG}$ lamp lights up when charging begins, and goes off when charging is completed. When charging is completed, remove the camera from the USB cradle.

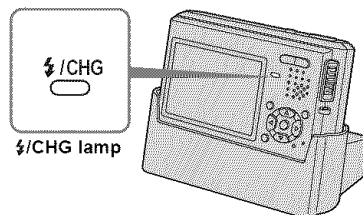

Disconnecting the AC Adaptor from the USB cradle

Hold the DC plug itself and the USB cradle as illustrated and disconnect the cable.

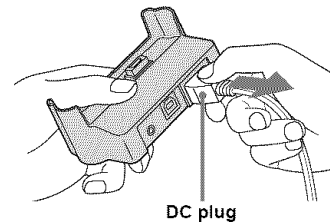

To charge the battery pack only using the AC Adaptor

You can charge the battery pack without the USB cradle, such as during your travels. Connect the DC plug of the AC Adaptor to the camera with ▲ mark facing as illustrated.

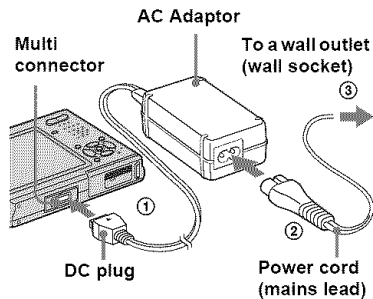

- Be sure to turn off your camera when charging the battery pack (page 16).
- When placing the camera, make sure the LCD screen is facing up.
- After charging the battery pack, disconnect the AC Adaptor both from the multi connector of the camera and from a wall outlet (wall socket).

To remove the battery pack

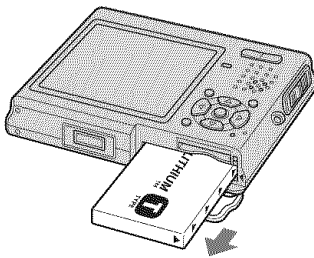

Open the battery/“Memory Stick Duo” cover, then hold the camera so that it faces downward and remove the battery pack.

- Be careful not to drop the battery pack when removing it.

Battery remaining indicator

The battery remaining indicator on the upper left side of the LCD screen shows the remaining shooting/viewing time and the battery remaining charge.

Remaining indicator



- The displayed time remaining may not be correct under certain circumstances or conditions.

Charging time

Approximate time to charge a completely discharged battery pack using the AC Adaptor at a temperature of 25°C (77°F).

Battery pack	Charging time (min.)
NP-FT1 (supplied)	Approx. 150

Number of images and battery life that can be recorded/ viewed

The tables show the approximate number of images and the battery life that can be recorded/viewed when you shoot images in normal mode with a fully charged battery pack at a temperature of 25°C (77°F). The numbers of images that can be recorded or viewed take into account changing the “Memory Stick Duo” as necessary. Note that the actual numbers may be less than indicated depending on the conditions of use.

Shooting still images

Under the average conditions¹⁾

Image size	NP-FT1 (supplied)		
	LCD back-light	No. of images	Battery life (min.)
5M	On	Approx. 170	Approx. 85
	Off	Approx. 200	Approx. 100
VGA	On	Approx. 170	Approx. 85
	Off	Approx. 200	Approx. 100

¹⁾ Shooting in the following situations:

-  (P.Quality) is set to [Fine]
- Shooting one time every 30 seconds
- The zoom is switched alternately between the W and T ends
- The flash strobes once every two times
- The power turns on and off once every ten times
- [AF Mode] is set to [Single] on the Setup screen

Viewing still images²⁾

Image size	NP-FT1 (supplied)	
	No. of images	Battery life (min.)
5M	Approx. 2600	Approx. 130
VGA	Approx. 2800	Approx. 140

²⁾ Viewing single images in order at about three second intervals

Shooting movies³⁾

	NP-FT1 (supplied)	
	LCD backlight	Battery life (min.)
Continuous shooting	On	Approx. 80
	Off	Approx. 100

³⁾ Shooting movies continuously with the image size [160]

- The number of images and the battery life that can be recorded/viewed are decreased under the following conditions:
 - The surrounding temperature is low
 - The flash is used
 - The camera has been turned on and off many times
 - The zoom is used frequently
 - [LCD Backlight] is set to [Bright] on the Setup screen
 - The battery power is low.
The battery capacity decreases as you use it more and more and as time passes (page 111).
 - [AF Mode] is set to [Monitor] or [Cont] on the Setup screen

Using the AC Adaptor

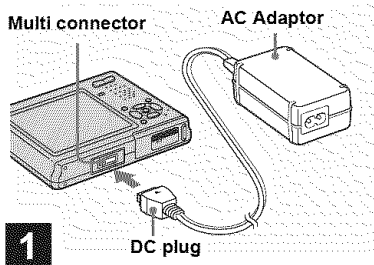

- 1** → Connect the AC Adaptor (supplied) to the multi connector of the camera.

When placing the camera, make sure the LCD screen is facing up.

Connect the plug with the ▲ mark facing up.

- Connect the AC Adaptor to an easily accessible wall outlet (wall socket) close by. If any trouble occurs while using the adaptor, immediately shut off the power by disconnecting the plug from the wall outlet (wall socket).

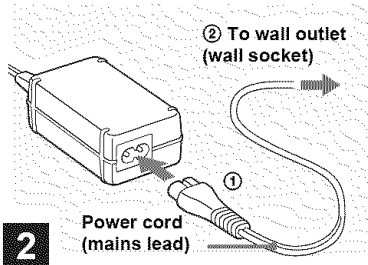

- 2** → Connect the power cord (mains lead) to the AC Adaptor and then to a wall outlet (wall socket).

- After using the AC Adaptor, disconnect it both from the multi connector of the camera and from a wall outlet (wall socket).
- The set is not disconnected from the AC power source (mains) as long as it is connected to the wall outlet (wall socket) even if the set itself has been turned off.

Using your camera abroad

Power sources

You can use your camera in any country or region with the AC Adaptor (supplied) within 100 V to 240 V AC, 50/60 Hz. Use a commercially available AC plug adaptor [a], if necessary, depending on the design of the wall outlet (wall socket) [b].

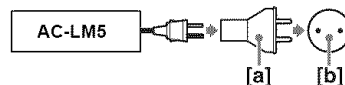

- Do not use an electronic transformer (travel converter), as this may cause a malfunction.

Turning on/off your camera

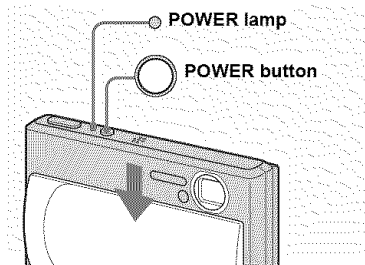

- ➔ Slide the lens cover in the direction of arrow or press the POWER button.

The POWER lamp (green) lights up and the power is on. When you turn on your camera for the first time, the Clock Set screen appears (page 17).

Turning off the power

Slide the lens cover in the opposite direction of the arrow or press the POWER button again. The POWER lamp goes out, and the camera turns off.

- If you open the lens cover too quickly, the camera might not turn on. If this happens, close the cover and then open it again more slowly.
- When opening the lens cover, be careful not to touch the lens.

Auto power-off function

If you do not operate the camera for about three minutes during shooting or viewing or when performing the Setup, the camera turns off automatically to prevent wearing down the battery. The auto power-off function only operates when the camera is operating using a battery pack. The auto power-off function also will not operate in the following circumstances.

- When viewing movies
- When playing back a slide show
- When a connector is plugged into the ψ (USB) jack or the A/V OUT (MONO) jack with the camera connected to the USB cradle.

How to use the control button

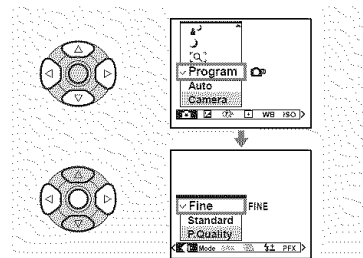



To change the current settings of the camera, bring up the menu or the Setup screen (page 44), and use the control button to make the changes.

For each item, press $\blacktriangle/\blacktriangledown/\blacktriangleleft/\blacktriangleright$ to select the desired value, then press \bullet or $\blacktriangle/\blacktriangledown/\blacktriangleleft/\blacktriangleright$ to make the setting.

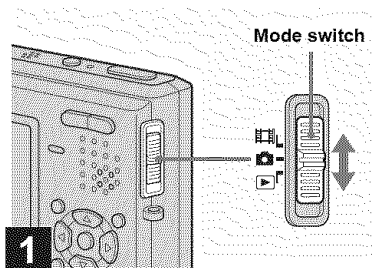
Setting the date and time



➔ Set the mode switch to .

- You can also carry out this operation when the mode switch is set to  or .
- To change the date and time on the Setup screen, select [Clock Set] in  (Setup 2) (pages 44 and 107), and perform the procedure from step **3**.

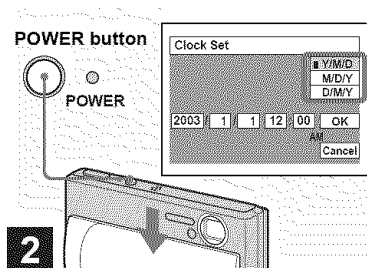

➔ Slide the lens cover or press the **POWER** button to turn on the camera.

The POWER lamp (green) lights up and the Clock Set screen appears on the LCD screen.

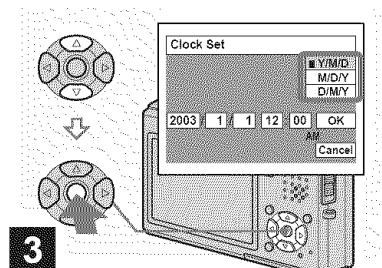

➔ Select the desired date display format with **▲/▼** on the control button, then press **●**.

Select from [Y/M/D] (year/month/day), [M/D/Y] (month/day/year) or [D/M/Y] (day/month/year).

- If the rechargeable button battery (page 109), which provides the power for saving the time data, ever becomes low, the Clock Set screen will appear again. When this happens, reset the date and time, by starting from step **3** above.

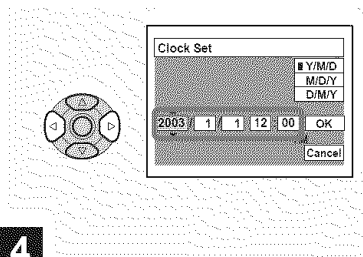

4

→ Select the year, month, day, hour or minute item you want to set with ◀/▶ on the control button.

The item to be set is indicated with ▲/▼.

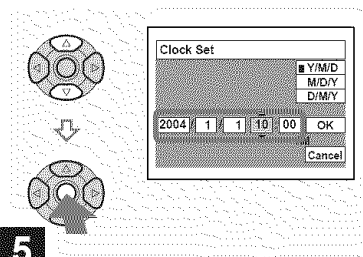

5

→ Set the numeric value with ▲/▼ on the control button, then press ● to enter it.

After entering the number, ▲/▼ moves to the next item. Repeat steps 4 and 5 until all of the items are set.

- If you selected [D/M/Y] in step 3, set the time on a 24-hour cycle.
- Midnight is indicated as 12:00 AM, and noon as 12:00 PM.

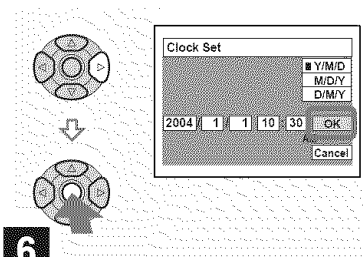

6

→ Select [OK] with ▶ on the control button, then press ●.

The date and time are entered and the clock starts to keep time.

- To cancel the date and time setting, select [Cancel] with ▲/▼/◀/▶ on the control button, then press ●.

Inserting and removing a "Memory Stick Duo"

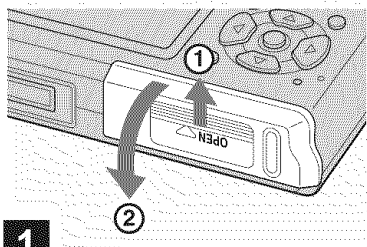

1

➔ Open the battery/"Memory Stick Duo" cover.

Slide the cover in the direction of the arrow.

- When using this camera, the Memory Stick Duo Adaptor (supplied) is not necessary.
- Be careful not to drop the battery pack when opening or closing the battery/"Memory Stick Duo" cover.
- For details on "Memory Stick Duo," see page 109.

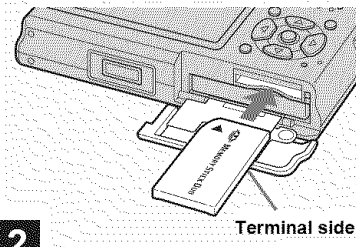

2

➔ Insert the "Memory Stick Duo."

Insert a "Memory Stick Duo" all the way in until it clicks as illustrated.

- When inserting a "Memory Stick Duo," make sure of the direction and insert it all the way to the connector. If the "Memory Stick Duo" is not inserted correctly, you may not be able to record or display images with the "Memory Stick Duo." And also it may result in malfunction of both the camera and "Memory Stick Duo."

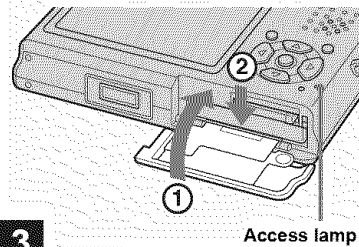

3

➔ Close the battery/"Memory Stick Duo" cover.

To remove a "Memory Stick Duo"

Open the battery/"Memory Stick Duo" cover, then push the "Memory Stick Duo" to pop it out.

- Whenever the access lamp is lit, the camera is recording or reading an image. Never open the battery/"Memory Stick Duo" cover or turn off the power at this time. The data may be corrupted.

Setting the still image size

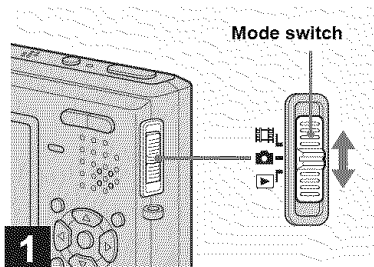

- ➔ Set the mode switch to , and slide the lens cover to turn on the power.

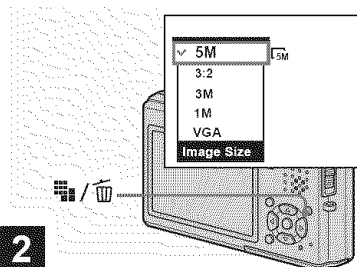



- ➔ Press  /  (Image Size).

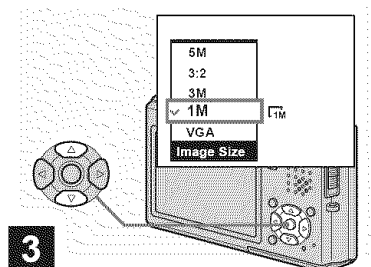

The Image Size setup appears.

- For details on the image size, see page 21.



- ➔ Select the desired image size with  /  on the control button.

The image size is set.

When the setting is complete, press  /  (Image Size) so that the Image Size setup disappears from the LCD screen.



- The image size selected here is maintained even when the power is turned off.

Image size

You can choose image size (number of pixels) and image quality (compression ratio) based on the kind of images you want to shoot. The larger you make the image size and the higher you make the image quality, the better your image, but also the larger the amount of data needed to preserve your image. This means you can save fewer images in your “Memory Stick Duo.”

Choose an image size and quality appropriately for the kind of images you want to shoot.

- When images recorded using earlier Sony models are played back on this camera, the display may differ from the actual image size.
- When the images are viewed on the LCD screen of the camera, they all look the same size.
- Number of shooting images can differ from these values according to shooting conditions.
- When the number of remaining shooting images is greater than 9999, the “>9999” indicator appears on the LCD screen.
- You can resize the images later (Resize function, see page 67).

Image size		Usage guidelines
5M ¹⁾ (2592×1944)	Large   Small	<ul style="list-style-type: none"> • For saving important images, printing in A4 size or printing A5 size high density images • For printing in postcard size • For recording a larger number of images • For attaching images to e-mail or creating home pages
3:2 ²⁾ (2592×1728)		
3M (2048×1536)		
1M (1280×960)		
VGA (640×480)		

¹⁾ The factory setting is [5M]. It is the highest image quality on this camera.

²⁾ Images are recorded in the same 3:2 aspect ratio as photograph printing paper or postcards, etc.

The number of images that can be saved in a “Memory Stick Duo”³⁾

The number of images that can be saved in Fine (Standard)⁴⁾ mode are shown below.

(Units: number of images)

Image size \ Capacity	16MB	32MB	64MB	128MB	MSX-M256	MSX-M512
	5M	6 (11)	12 (23)	25 (48)	51 (96)	92 (174)
3:2	6 (11)	12 (23)	25 (48)	51 (96)	92 (174)	188 (354)
3M	10 (18)	20 (37)	41 (74)	82 (149)	148 (264)	302 (537)
1M	24 (46)	50 (93)	101 (187)	202 (376)	357 (649)	726 (1320)
VGA	97 (243)	196 (491)	394 (985)	790 (1975)	1428 (3571)	2904 (7261)

³⁾ When [Mode] (REC Mode) is set to [Normal]

For the number of images that can be saved in other modes, see page 100.

⁴⁾ For more information about the image quality (compression ratio), see page 44.

Basic still image shooting — Using auto adjustment mode

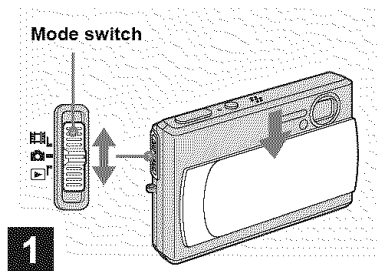

- ➔ Set the mode switch to , and slide the lens cover to turn on the power.

The name of the folder where the image will be recorded appears on the LCD screen for approximately five seconds.

- This camera can create new folders and select folders to be stored in the “Memory Stick Duo” (page 45).

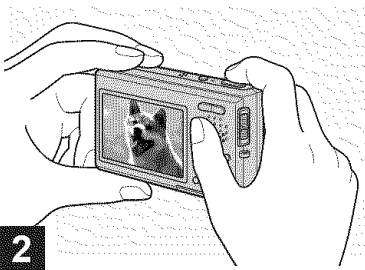

- ➔ Hold the camera steadily with both hands and position the subject in the center of the focus frame.

Do not touch the lens portion, flash portion, or microphone (page 8) when you hold the camera.

- The minimum focal distance to a subject is approx. 50 cm (19 3/4 inches). To shoot subjects at distances closer than this, use close-ups (Macro) mode (page 27).

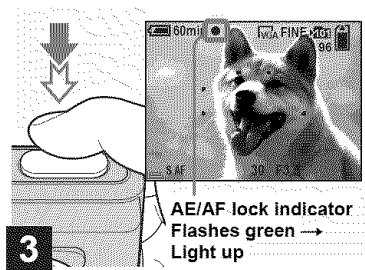

- ➔ Press and hold the shutter button halfway down.

The beep sounds but the image is not yet recorded. When the AE/AF lock indicator changes from flashing to steadily lit, the camera is ready for shooting. (The LCD screen may be frozen for a split second depending on the subject.)

- If you release the shutter button, shooting will be canceled.
- When the camera does not beep, the AF adjustment is not complete. You can continue to shoot, but the AF is not set properly (except in Continuous AF, page 48).

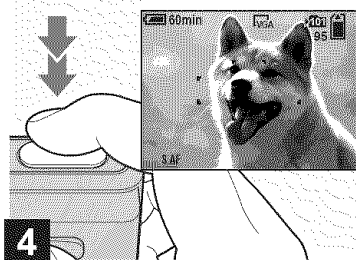



4

→ Press the shutter button fully down.

The shutter sounds. The image will be recorded in the “Memory Stick Duo.” When “Recording” disappears from the LCD screen, you can shoot the next image.

- The frame indicated on the LCD screen shows the focus adjustment range (AF range finder, page 47).
- When operating the camera using a battery pack, if you do not operate the camera for a while during recording or playback, the camera turns off automatically to prevent wearing down the battery (page 16).

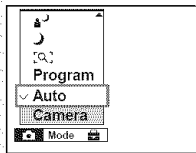

Mode switch

When you set the mode switch to , the functions that can be used change as follows according to  (Camera) in the menu.



Still image auto shooting [Auto]

The focus, exposure and white balance are automatically adjusted as needed to allow easy shooting. In addition, the image quality is set to [Fine] (page 44), the AF range finder frame is set to [Multi AF], and the metering mode is set to [Multi] (pages 47 and 52).

Only , [Mode] (REC Mode) and  (Setup) appear in the menu.

Still image program shooting [Program]

The necessary adjustments are made automatically like still image auto shooting, but you can also change the focus and other adjustments as desired. In addition, you can also set the desired shooting functions using menus (pages 43 and 102).

 (Magnifying glass mode) (page 32)

 (Twilight mode) (page 32)

 (Twilight portrait mode) (page 32)

 (Landscape mode) (page 33)





 (Snow mode) (page 33)

 (Beach mode) (page 33)

 (High-speed shutter mode) (page 33)

 (Fireworks mode) (page 33)

To switch the shooting method

- 1 Set the mode switch to .
- 2 Press MENU.
- 3 Select  (Camera) with  on the control button.
- 4 Select the desired shooting mode with  on the control button.

Auto Focus

When you try to shoot a subject that is difficult to focus on, the AE/AF lock indicator changes to flashing slowly. The Auto Focus function may have difficulty working under the following conditions. In such cases, release the shutter button, then recompose the shot and focus again.

- The subject is distant from the camera and dark.
- The contrast between the subject and its background is poor.
- The subject is seen through glass, such as a window.
- A fast-moving subject.
- The subject reflects or has a lustrous finish, such as a mirror or a luminous body.
- A flashing subject.
- A backlit subject.

There are two Auto Focus functions: “AF range finder frame” which sets the focus position according to the subject position and size, and “AF mode” which sets the focus start/finish timing according to the AF response and the battery consumption. See page 47 for details.

Checking the last image you shot — Quick Review

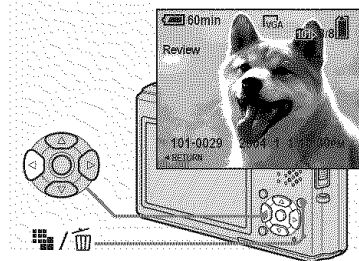

➔ Press ◀ (◁) on the control button.

To return to the normal shooting mode, press lightly on the shutter button or press ◀ (◁) again.

To delete the image displayed on the LCD screen

- 1 Press / (Delete).
- 2 Select [Delete] with ▲ on the control button, then press ●.
The image is deleted.

- The image may appear rough right after playback starts due to the image processing.

Indicators on the LCD screen during shooting

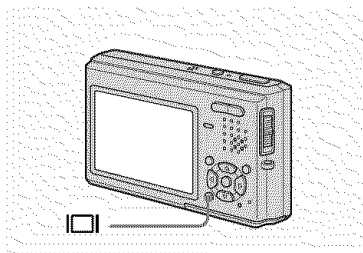

Indicators on

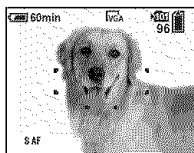

Histogram on (Image information can also be displayed during playback.)

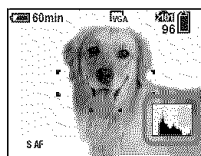

Indicators off

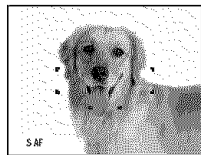

LCD backlight off

Each time you press , the display changes in the following order.

- For a detailed description of the indicators, see page 114.
- For a detailed description of the histogram, see page 51.
- You can extend the battery remaining time by turning off the LCD backlight.
- When shooting/viewing movies, the status of the LCD screen changes as follows: Indicators on → Indicators off → LCD backlight off
- This setting is maintained even when the power is turned off.

Using the zoom feature

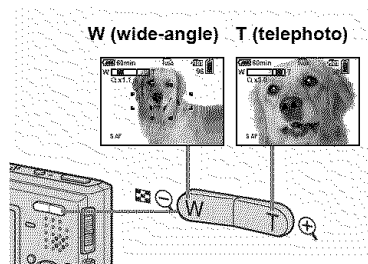

➔ Press the zoom button to choose the desired image size for shooting.

The minimum focal distance to the subject

Approx. 50 cm (19 3/4 inches) from the lens surface

- You cannot change the zoom scale while shooting movie.



Zoom

Your camera is equipped with zoom functions that enlarge the image using optical zoom and two types of digital processing. Digital zoom can be selected from smart zoom or precision digital zoom. When digital zoom is set, the zoom method switches from optical zoom to digital zoom when the zoom scale exceeds 3×

To use only the optical zoom, set [Digital Zoom] to [Off] on the Setup screen (page 106). In this case, the digital zoom area does not appear in the zoom scale display bar on the LCD screen, and the maximum zoom is 3×. The enlargement method and the zoom scale differ according to the image size and the zoom type, so select the zoom to match the shooting purpose.

When digital zoom is set and you press the zoom button, the zoom scaling indicator appears on the LCD screen as follows.

The W side of this line is optical zoom, and the T side is digital zoom

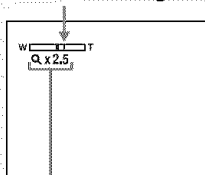

Zoom scaling indicator

- The **Q** indicator differs according to the zoom type.
 - Optical zoom: **Q** ×
 - Smart zoom: **5Q** ×
 - Precision digital zoom: **PQ** ×
- The AF range finder frame does not appear when using the digital zoom. The **AF**, **AF** or **AF** indicators flashes, and AF operates with priority on subjects located near the center.

Smart zoom

The image is enlarged with almost no distortion. This lets you use smart zoom with the same feeling as optical zoom. To set smart zoom, set [Digital Zoom] to [Smart] on the Setup screen (page 106).

When you purchase your camera, it is set to smart zoom.

The maximum zoom scale depends on the selected image size as follows.

Image size	Maximum zoom scale
3M	3.8×
1M	6.1×
VGA	12×

When you purchase your camera, the image size is set to [5M]. Smart zoom cannot be used when the image size is set to [5M] or [3:2], so set a different image size.

- When using the smart zoom, the image on the LCD screen may look rough. However, this phenomenon has no effect on the recorded image.
- You cannot use the smart zoom in the Multi Burst mode.

Precision digital zoom

All image sizes are enlarged up to a maximum 6×. This function cuts out and enlarges a certain portion of the image, so the image quality deteriorates. To set precision digital zoom, set [Digital Zoom] to [Precision] on the Setup screen (page 106).

Shooting close-ups — Macro

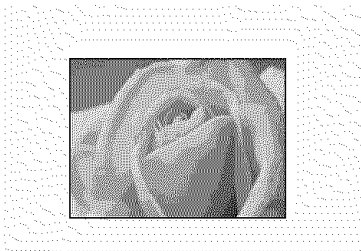

The close-ups (Macro) recording mode is used when zooming up subjects such as flowers or insects. Setting the zoom all the way to the W side lets you shoot subjects at distances as close as 8 cm. However, the minimum focus distance varies according to the zoom position. Therefore, shooting with the zoom set all the way to the W side is recommended.

When the zoom is set all the way to the W side:

Approx. 8 cm (3 1/4 inches) from the lens surface

When the zoom is set all the way to the T side:

Approx. 25 cm (9 7/8 inches) from the lens surface

- Using Spot AF is recommended (page 47).
- To shoot at even closer distances than close-ups (Macro) recording, use (Magnifying glass mode) (page 32).

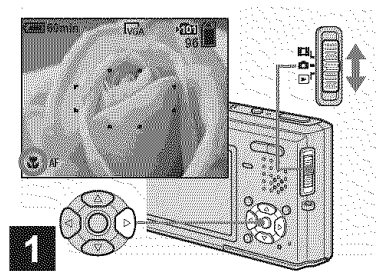

- ➔ Set the mode switch to , and press on the control button.

The (macro) indicator appears on the LCD screen.

- If the menu is currently displayed, press MENU first so that the menu disappears.
- You can also carry out this operation when the mode switch is set to .
- You cannot use this function when (Camera) in the menu is set to (Magnifying glass mode), (Twilight mode), (Landscape mode) and (Fireworks mode).

Using the self-timer

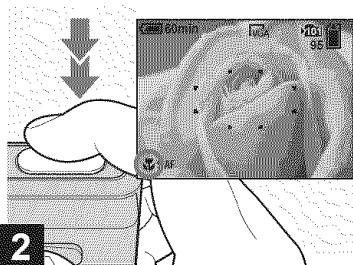



- 2** → Center the subject in the frame. Press and hold the shutter button halfway down, then press the shutter button fully down.

To return to normal recording mode

Press **▶** (👁) on the control button again. The 👁 indicator disappears from the LCD screen.

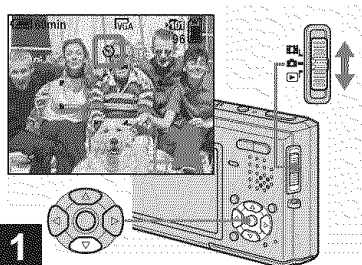
- When shooting in close-ups (Macro) mode, the focus depth becomes extremely shallow, and the entire subject may not be in focus.
- When shooting in close-ups (Macro) mode, the AF speed drops in order to focus accurately on close subjects.



- 1** → Set the mode switch to , and press **▼** (😊) on the control button.

The 😊 (self-timer) indicator appears on the LCD screen.

- When recording with the self-timer, place the camera in a stable location. If you place the camera in an unstable location for recording, the camera may fall and become damaged or malfunction.
- If the menu is currently displayed, press MENU first so that the menu disappears.
- You can also carry out this operation when the mode switch is set to .

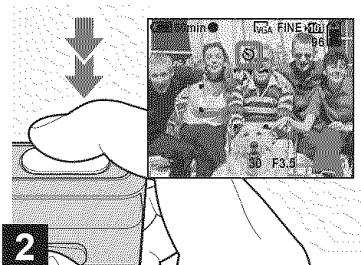

- 2** → Center the subject in the frame. Press and hold the shutter button halfway down, then press the shutter button fully down.

The self-timer lamp (page 8) flashes and a beep sounds after you press the shutter button until the shutter operates (approximately 10 seconds later).



To cancel the self-timer in the middle of the operation

Press **▼** (😊) on the control button again. The 😊 indicator disappears from the LCD screen.

- If you press the shutter button while standing in front of the camera, the focus and the exposure may not be correctly set.

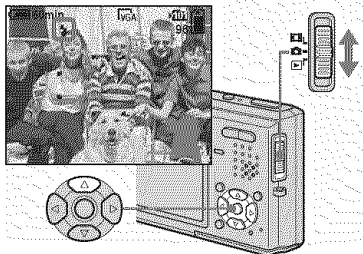
Selecting a flash mode





➔ Set the mode switch to , and press  (⚡) on the control button repeatedly to select a flash mode.





Each time you press  (⚡), the indicator changes as follows.

No indicator (Auto): The flash automatically strobos when shooting images in a dark place. The factory setting is Auto.

 (Forced flash): The flash strobos regardless of the surrounding brightness.

 (Slow synchro): The flash strobos regardless of the surrounding brightness. The shutter speed is slow in a dark place, so you can clearly shoot the background that is out of flash light.

 (No flash): The flash does not strobe regardless of the surrounding brightness.

- If the menu is currently displayed, press MENU first so that the menu disappears.
- When [ISO] is set to [Auto] in the menu, the recommended shooting distance using the flash is approx. 0.3 m to 1.5 m (11 7/8 inches to 59 1/8 inches) (W)/0.5 m to 1.5 m (19 3/4 inches to 59 1/8 inches) (T).
- You can change the brightness of the flash with  (Flash Level) in the menu (page 55). (You cannot change the brightness of the flash while  (Camera) is set to [Auto] in the menu.)
- When using the  (Slow synchro) or  (No flash) mode, the shutter speed becomes slower in dark places. Be careful not to allow your hand to shake while holding the camera.
- While charging the flash, the  /CHG lamp flashes. After the charging is complete, the lamp goes out.
- This setting is maintained even when the power is turned off.

To prevent subjects' eyes from appearing red

Set [Red Eye Reduction] to [On] on the Setup screen (page 106). The  indicator appears on the LCD screen, and the flash pre-strobes before shooting to reduce the red-eye phenomenon.

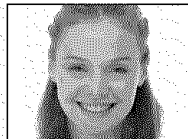
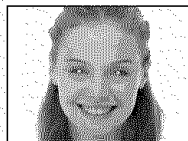

- Red-eye reduction may not produce the desired effects depending on individual differences, the distance to the subject, if the subject does not see the pre-strobe, or other conditions.

Shooting images with the AF illuminator

The AF illuminator is fill light to focus more easily on a subject in dark surroundings. The **AF-ON** appears on the LCD screen and the AF illuminator emits red light when the shutter button is pressed halfway until the focus is locked.

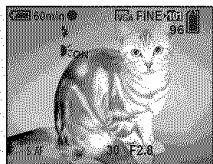

When this function is not needed, set [AF Illuminator] to [Off] on the Setup screen (page 106).

- If AF illuminator light does not reach the subject sufficiently or the subject has no contrast, focus will not be achieved. (A distance up to approximately 2.2 m (86 5/8 inches) is recommended.)
- Focus is achieved as long as AF illuminator light reaches the subject, even if the light is slightly off the center of the subject.
- When the focus preset distance is set (page 49), the AF illuminator does not function.

- The AF range finder frame does not appear. The **[AF]**, **[AF]** or **[AF]** indicators flashes, and AF operates with priority on subjects located near the center.
- The AF illuminator operates only when **[CAMERA]** (Camera) is set to [Auto], [Program], [Q] (Magnifying glass mode), [M] (Twilight portrait mode), [S] (Snow mode) or [B] (Beach mode) in the menu.
- The AF illuminator emits very bright light. Although there are no problems with safety, directly looking into the AF illuminator emitter at close range is not recommended, as you may see residual spots for several minutes afterwards, such as after looking into a flashlight.

Inserting the date and time on a still image

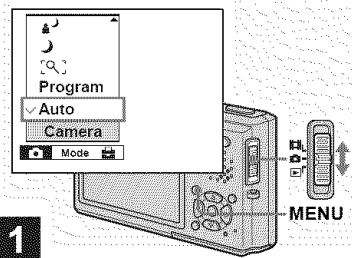

➔ Set the mode switch to **[CAMERA]**, then press **MENU**.

The menu appears.

- When images are shot with the date and time superimposed, the date and time cannot be removed later.
- The date and time do not appear on the LCD screen during shooting, instead, the **DATE** indicator appears on the LCD screen. The actual date and time appear in red during playback only.
- The date and time is not inserted in Multi Burst mode.
- You can also carry out this operation with the mode switch set to **[M]** or **[P]**.

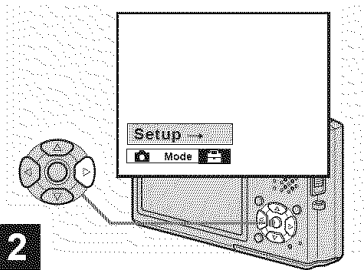

2

→ Press **▶** on the control button to advance to , then press **▶** again.

The Setup screen appears.

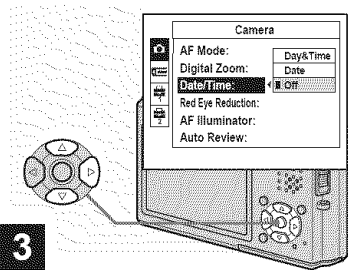

3

→ Select  (Camera) with **▲** on the control button, then press **▶**.
Select **[Date/Time]** with **▲/▼**, then press **▶**.

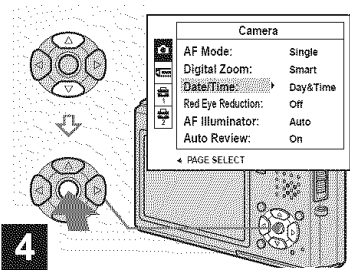

4

→ Select the date and time setting with **▲/▼** on the control button, then press **●**.

Day&Time: Superimposes the date, hour, and minute onto the image.

Date: Superimposes the year, month and day onto the image.

Off: Does not superimpose the date and time onto the image.

After the setting has been completed, press **MENU** first so that the menu disappears, and shoot the image.

- If you select **[Date]**, the date is superimposed onto the image in the order selected in “Setting the date and time” (page 17).
- This setting is maintained even when the power is turned off.

Shooting according to scene conditions — Scene Selection



You can select from eight different shooting modes (magnifying glass, twilight, twilight portrait, landscape, snow, beach, high-speed shutter and fireworks) in accordance with the shooting conditions. The camera automatically makes the optimum settings to match the scene, making it easy to shoot high quality images even under difficult conditions.

[Q] Magnifying glass mode

The subject appears on the LCD screen magnified by up to 3.3×. This lets you see details that would otherwise be difficult to confirm with the naked eye.

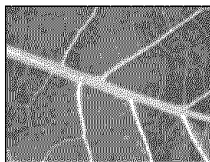
Distance to the subject	Magnification scale
1 cm (13/32 inch)	3.3×
2 cm (13/16 inch)	2.1×
5 cm (2 inches)	1.0×
10 cm (4 inches)	0.5×
20 cm (7 7/8 inches)	0.3×



- The close-ups (Macro) function does not work.
- You cannot shoot in Exposure Bracket, Burst and Multi Burst mode.
- The flash is set to  (Forced flash) or  (No flash).
- The focal distance to a subject is approx. 1 cm to 20 cm (13/32 inch to 7 7/8 inches).
- The optical zoom is locked to the W side and cannot be used.
- When you press the zoom button, the image is enlarged using the digital zoom.

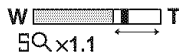

☾ Twilight mode

Allows you to shoot night scenes at far distance without losing the dark atmosphere of the surroundings. The shutter speed becomes slower, so be careful not to allow your hand to shake while holding the camera.



- The close-ups (Macro) function does not work.
- You cannot shoot in Exposure Bracket, Burst and Multi Burst mode.
- You cannot use the flash.
- Place the camera in a stable location and secure it before shooting.

☾ Twilight portrait mode

Suitable for shooting portraits in dark places. Allows you to shoot sharp images of people in dark places without losing the dark atmosphere of the surroundings. The shutter speed becomes slower, so be careful not to allow your hand to shake while holding the camera.





- You cannot shoot in Exposure Bracket, Burst and Multi Burst mode.
- The flash is set to  (Slow Synchro).

Landscape mode

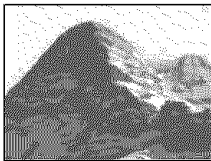
Focuses only on a distant subject to shoot landscapes, etc.





- The close-ups (Macro) function does not work.
- The flash is set to  (Forced flash) or  (No flash).

Snow mode

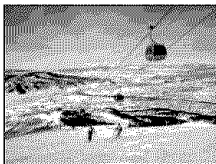
When shooting snowy scenes or other places where the whole screen appears white, use this mode to prevent sunken colors and record clear and sharp images.





- The flash is set to  (Forced flash) or  (No flash).

Beach mode

When shooting seaside or lakeside scenes, the blue of the water is clearly recorded.





- The flash is set to  (Forced flash) or  (No flash).

High-speed shutter mode

Use this mode to shoot moving subjects outdoors or in other bright places.



- The shutter speed becomes faster, so images shot in dark places become darker.
- The flash is set to  (Forced flash) or  (No flash).

Fireworks mode

Fireworks are recorded in all their splendor by setting the focus distance to infinity. The shutter speed becomes slower, so be careful not to allow your hand to shake while holding the camera.

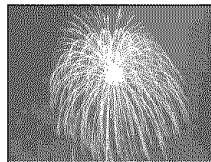

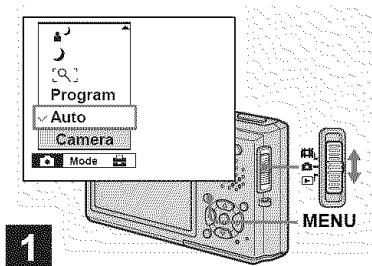

- The close-ups (Macro) function does not work.
- You cannot use the flash.
- You can change the shutter speed by setting an EV adjustment value (page 50).
- You cannot set the white balance.
- You cannot shoot in Exposure Bracket, Burst and Multi Burst mode.
- Place the camera in a stable location and secure it before shooting.

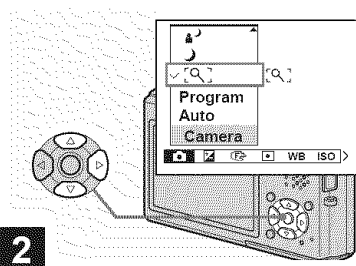

- 1** → Set the mode switch to , then press MENU.

The menu appears.





- 2** → Select  (Camera) with ◀ on the control button, then select the desired mode with ▲/▼.

To return to normal mode

Select [Auto] or [Program] with ▲/▼ on the control button.

- The setting is maintained even when the power is turned off.

NR slow shutter

The NR slow shutter mode removes noise from recorded images, providing clear images. When the shutter speed is 1/6 second or slower in ,  (Twilight portrait mode) and  (Fireworks mode), the camera automatically enters the NR slow shutter function and “NR” is indicated next to the shutter speed indicator.



Press the shutter button fully down.



Then the screen turns black.



Finally, when “Processing” disappears, the image has been recorded.

- When the NR slow shutter function is activated, be careful not to allow your hand to shake while holding the camera.

Viewing an index screen (nine-image or sixteen-image)

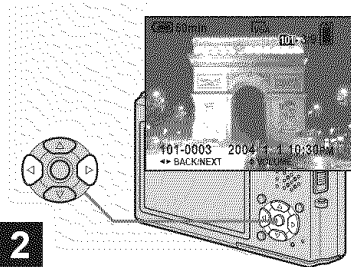

➔ Select the desired still image with ◀/▶ on the control button.

- ◀ : To display the preceding image
- ▶ : To display the next image

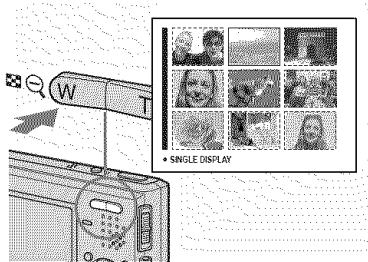

➔ Press  (Index) once.

The display switches to the **index (nine-image) screen**.

To display the next (previous) index screen

Press ▲/▼/◀/▶ on the control button to move the yellow frame up/down/left/right.

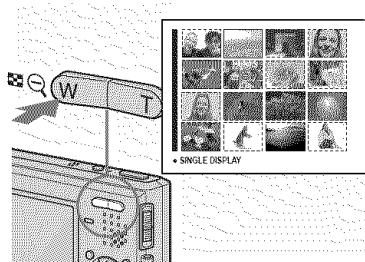

➔ Press  (Index) once more.

The display switches to the **index (sixteen-image) screen**.

To display the next (previous) index screen

Press ▲/▼/◀/▶ on the control button to move the yellow frame up/down/left/right.

To return to the single-image screen

Press  (Index) T side repeatedly, or press ● on the control button.

Viewing images on a TV screen

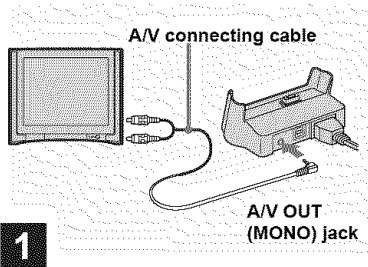

- ➔ Connect the A/V connecting cable (supplied) to the A/V OUT (MONO) jack of the USB cradle (supplied) and the audio/video input jacks of the TV.

If your TV has stereo type input jacks, connect the audio plug (black) of the A/V connecting cable to the left audio input jack.

- When the USB cable is connected to the USB cradle, remove the USB cable from the USB cradle.
- Turn off both the camera and the TV before connecting the camera and the TV with the A/V connecting cable.

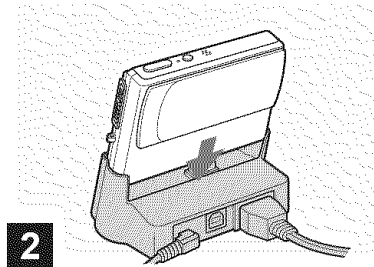

- ➔ Connect the camera to the USB cradle.

Connect the camera as illustrated.

- Make sure the camera is securely connected to the USB cradle.

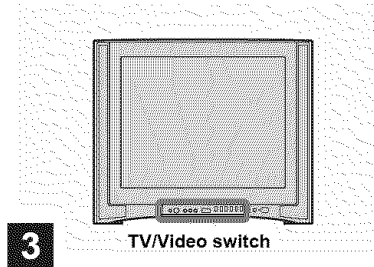

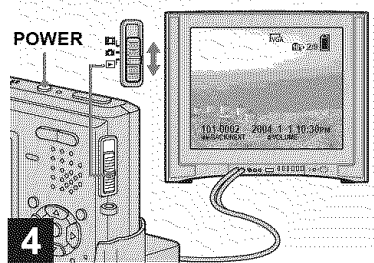

- ➔ Turn on the TV and set the TV/Video switch to “Video”.

- The name and location of this switch may differ depending on your TV. For details, see the operating instructions supplied with the TV.



➔ **Set the mode switch to , and turn on the camera.**

Press   on the control button to select the desired image.

- When using your camera abroad, it may be necessary to switch the video output signal to match that of your TV system (page 107).

Viewing images on a TV screen

If you want to view images on a TV screen, you need a TV with a video input jack and the A/V connecting cable (supplied). The color system of the TV must match that of your digital still camera. Check the following lists:

NTSC system

Bahama Islands, Bolivia, Canada, Central America, Chile, Colombia, Ecuador, Jamaica, Japan, Korea, Mexico, Peru, Surinam, Taiwan, the Philippines, the U.S.A., Venezuela, etc.

PAL system

Australia, Austria, Belgium, China, Czech Republic, Denmark, Finland, Germany, Holland, Hong Kong, Italy, Kuwait, Malaysia, New Zealand, Norway, Portugal, Singapore, Slovak Republic, Spain, Sweden, Switzerland, Thailand, United Kingdom, etc.

PAL-M system

Brazil

PAL-N system



Argentina, Paraguay, Uruguay

SECAM system

Bulgaria, France, Guiana, Hungary, Iran, Iraq, Monaco, Poland, Russia, Ukraine, etc.

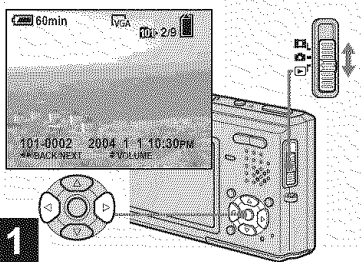
Deleting images



- 1** → Set the mode switch to , and turn on the camera. Press  on the control button to select the image you want to delete.

- Note that you cannot restore deleted images.

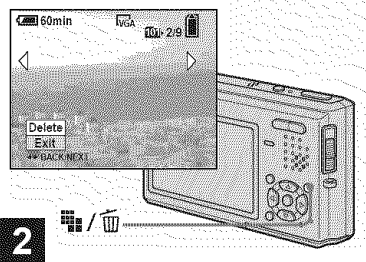



- 2** → Press  (Delete).

The image has not yet been deleted at this point.

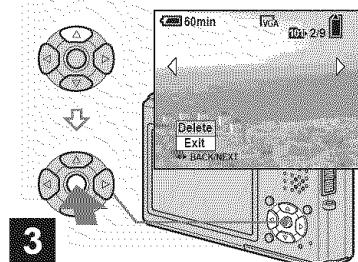



- You cannot delete the protected image (page 66).





- 3** → Select [Delete] with  on the control button, then press .

The message “Access” appears, and the image has been deleted.

To continue and delete other images



Display the image to be deleted with  on the control button. Then, select [Delete] with  and press .

To cancel deleting

Select [Exit] with  on the control button, then press .

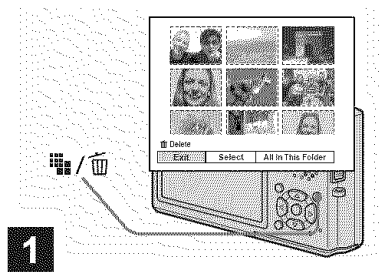

Deleting images in index (nine-image or sixteen-image) mode





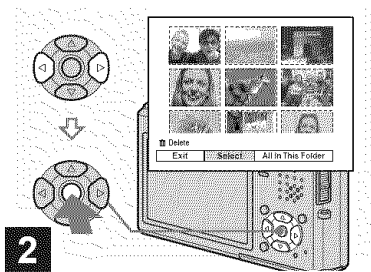

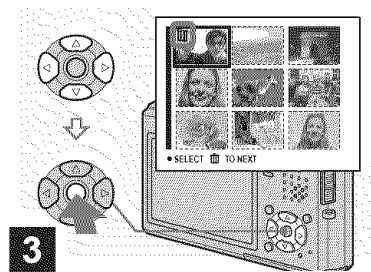

- 1** → While an index (nine-image/sixteen-image) screen (page 36) is displayed, press  /  (Delete).

- Note that you cannot restore deleted images.





- 2** → Select [Select] with  /  on the control button, then press .



- 3** → Select an image you want to delete with  /  /  /  on the control button, then press .

The  (Delete) indicator appears on the selected image. At this point, the image has not yet been deleted. Repeat this step for all of the images you want to delete.

- To cancel a selection, select the image, then press  again so that the  indicator disappears.

Formatting a "Memory Stick Duo"

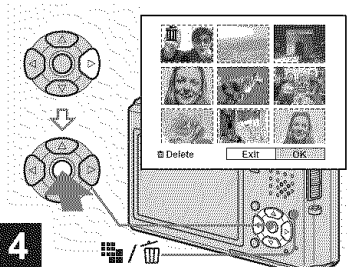

- 4** → Press / (Delete) and select [OK] with on the control button, then press .

The message "Access" appears, and the images have been deleted.

To cancel deleting

Select [Exit] with on the control button, then press .

To delete all the images in the folder

Select [All In This Folder] with on the control button in step **2**, then press . Select [OK], then press . All of the unprotected images in the folder are deleted. To cancel deleting, select [Cancel], then press .

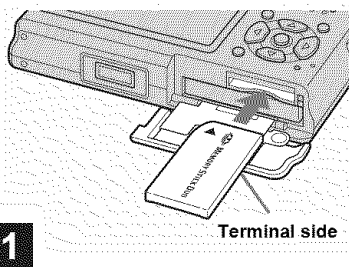

- 1** → Insert the "Memory Stick Duo" you want to format into the camera.

- The term "formatting" means preparing a "Memory Stick Duo" to record images; this process is also called "initialization." The "Memory Stick Duo" provided with this camera, and those available commercially, are already formatted, and can be used immediately.
- **When you format a "Memory Stick Duo," be aware that all data including protected images in the "Memory Stick Duo" will be permanently erased.**

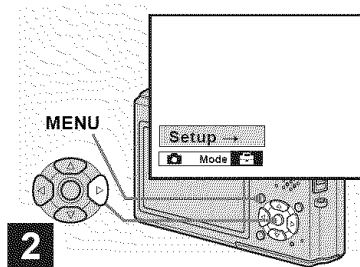

- 2** → Turn on the camera, then press MENU. Press on the control button to advance to , then press again.

The Setup screen appears.

- This operation is available no matter what position the mode switch is in.



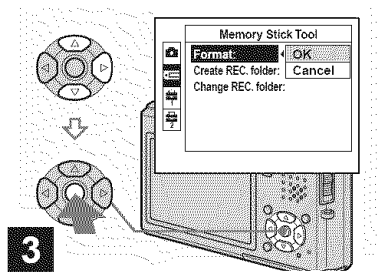

- Select **[Memory Stick Tool]** with **▲/▼** on the control button. Select **[Format]** with **▶**, then press **▶**. Select **[OK]** with **▲**, then press **●**.

To cancel the formatting

Select **[Cancel]** with **▼** on the control button, then press **●**.

- Using the AC Adaptor is recommended to prevent the power from turning off partway through formatting.

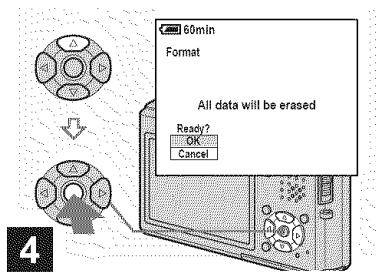

- Select **[OK]** with **▲** on the control button, then press **●**.

The message "Formatting" appears. When this message disappears, the format is complete.

How to setup and operate your camera

The usage of the menus and Setup screen items that are most frequently used for “Advanced operations” is described below.

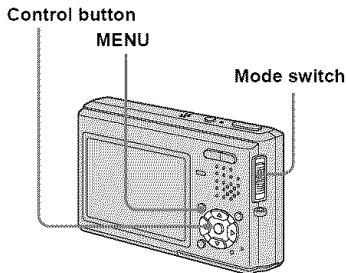

Changing the menu settings

1 Press MENU.

The menu appears.

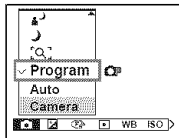

2 Press ◀/▶ on the control button to select the item you want to set.

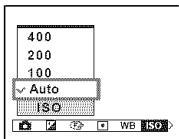

3 Press ▲/▼ on the control button to select the desired setting.

The selected setting is enlarged and the setting is entered.

When a ▲ or ▼ mark is displayed next to a setting item

This means that there are also other setting items. To display these other items, scroll the screen with ▲/▼.

To turn off the menu display

Press MENU again.

- You cannot select items displayed in gray.
- For a detailed description of the menu items, see page 102.

Changing the items on the Setup screen

1 Press MENU.

The menu appears.

2 Press **▶** on the control button to advance to , then press **▶** again.

The Setup screen appears.

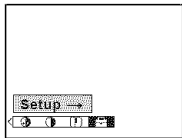

3 Press **▲/▼/◀/▶** on the control button to select the item you want to set.

The frame of the selected item turns yellow.

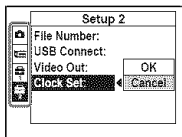

4 Press **●** on the control button to enter the setting.

To cancel the Setup screen

Press MENU again.

To return to the menu from the Setup screen

Press **◀** on the control button to return to the position enclosed by the frame in step **3**, then press **◀** again.

- For a detailed description of the Setup items, see page 106.

Deciding the still image quality

Mode switch:

You can select the still image quality from [Fine] or [Standard].

Before operation

Set  (Camera) in the menu to other than [Auto] (pages 43 and 102).

Control button

MENU

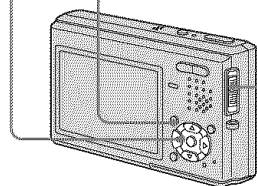

Mode switch



1 Set the mode switch to .

2 Press MENU.

The menu appears.

3 Select  (P.Quality) with , then select the desired image quality with .

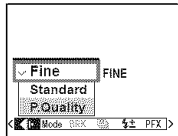

Creating or selecting a folder

Mode switch: / / 

Your camera can create multiple folders within a “Memory Stick Duo.” You can select the folder used to store images. When not creating a new folder,

“101MSDCF” folder is selected as the recording folder.

You can create folders up to “999MSDCF.”

Before operation

Set the menu to the Setup screen (pages 44 and 106).

Control button



MENU

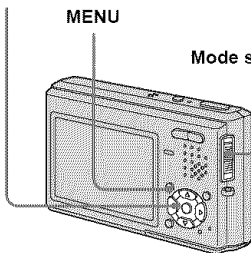



Mode switch



- Up to 4000 images can be stored in one folder. When the folder capacity is exceeded, a new folder is automatically created.



Creating a new folder

1 Select  (Memory Stick Tool) with / .

2 Select [Create REC. Folder] with , , and [OK] with , then press .

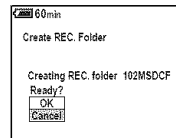
The creating folder screen appears.



3 Select [OK] with , then press .

A new folder is created with a number one higher than the largest number in the “Memory Stick Duo”, and the folder becomes the recording folder.

To cancel folder creation

Select [Cancel] in step **2** or **3**.

- Once you create a new folder, you cannot delete the new folder with the camera.
- Images are recorded in the newly created folder until a different folder is created or selected.

Changing the recording folder

- 1 Select  (Memory Stick Tool) with $\blacktriangle/\blacktriangledown$.
- 2 Select [Change REC. Folder] with $\blacktriangleright/\blacktriangledown$, and [OK] with $\blacktriangleright/\blacktriangle$, then press \bullet .

The recording folder selection screen appears.

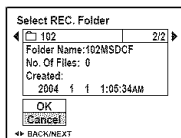

- 3 Select the desired folder with $\blacktriangle/\blacktriangleright$, and [OK] with \blacktriangle , then press \bullet .

To cancel changing the recording folder

Select [Cancel] in step **2** or **3**.

- You cannot select the “100MSDCF” folder as a recording folder.
- The image is stored in the newly selected folder. You cannot move images to a different folder with this camera.

Choosing an auto focus method

Mode switch: /

You can set the AF range finder frame and the AF mode.



AF range finder frame

The AF range finder frame selects the focus position according to the subject position and size.

AF Mode

The AF mode sets the focus start/finish timing according to the AF response and the battery consumption.

Before operation

When shooting still images, set  (Camera) in the menu to other than [Auto] or  (Fireworks mode) (pages 43 and 102).

Control button

MENU

Mode switch

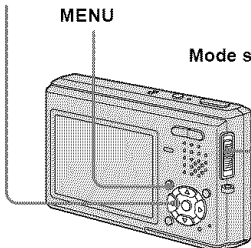

Choosing a focus range finder frame

— AF range finder

Multipoint AF

The camera calculates the distance in five places to the left, right, top, bottom and in the center of the image, letting you shoot using the auto focus function without worrying about the image composition. This is useful when it is difficult to focus on the subject because it is not in the center of the frame. You can check the position where the focus was adjusted using the green frame.



The Multipoint AF is the factory setting.

Center AF

This is useful for focusing on a subject near the center of the frame. Use together with the AF lock function lets you shoot in the desired image composition.





Spot AF

This is useful when focusing on an extremely small subject or a narrow area. Use together with the AF lock function lets you shoot in the desired image composition. Take care to hold the camera steady so that the subject does not deviate from the range finder frame.

1 Set the mode switch to  or .

2 Press MENU.



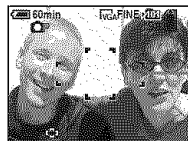

The menu appears.

3 Select  (Focus) with , , then select the desired AF range with , .



AF range finder frame

The focus is adjusted automatically. When you press and hold the shutter button halfway down and the focus is adjusted, the color of the AF range finder frame changes from white to green.

- When you are shooting movies and you choose Multipoint AF, the distance to the center of the screen is estimated as an average, so the AF works even with a certain amount of vibration. The AF range finder frame is . Center AF and Spot AF automatically focus only on selected frame, so these are convenient when you want to focus only on what you aim at.
- When you use the digital zoom or AF illuminator, priority AF movement is given to subjects in or near the center of the frame. In this case the ,  or  indicator flashes and the AF range finder frame is not displayed.

Choosing a focus operation

— AF Mode

Single AF (S AF)

This mode is useful for shooting stationary subjects. The focus is not adjusted before the shutter button is pressed and held halfway down. When the shutter button is pressed and held halfway down and AF lock is complete, the focus is locked.

The factory setting is Single AF.

Monitoring AF (M AF)

This shortens the time needed for focusing. The camera automatically adjusts the focus before the shutter button is pressed and held halfway down, letting you compose images with the focus already adjusted. When the shutter button is pressed and held halfway down and AF lock is complete, the focus is locked.

- Battery consumption may be faster than in Single AF mode.

Continuous AF (C AF)

The camera adjusts the focus before the shutter button is pressed and held halfway down, and then continues to adjust the focus even after AF lock is completed. This allows shooting of moving subjects with continued focus.

- The focus is not adjusted after the lock is completed in the following cases, and the C AF indicator flashes. The camera operates in Monitoring AF mode.
 - When shooting in the dark place
 - When shooting with a slow shutter speed
- The AF range finder frame is set to Center AF.
- Focus adjustment may not be able to keep up when shooting fast moving subjects.
- There is no lock sound when the focus is adjusted.
- When recording with the self timer, the focus is locked when you press the shutter button all the way down.
- Battery consumption may be faster than in any other AF mode.

Before operation

Set the menu to the Setup screen (pages 44 and 106).

- 1 Select  (Camera) with ▲.
- 2 Select [AF Mode] with ►/▲, and select the desired mode with ►/▲/▼.

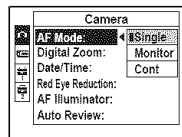

When you select [Single] or [Monitor], also select the AF range finder frame (page 47).

Shooting techniques

When shooting with the subject at the edge of the frame, or when using Center AF or Spot AF, the camera may focus on the center instead of on the subject at the edge of the frame. In a case like this, use AF lock to focus on the subject, and then recompose the picture and shoot (except in Continuous AF mode).

Compose the shot so that the subject is centered in the AF range finder, and press the shutter button halfway down.

When the AE/AF lock indicator stops flashing and remains on, return to the fully composed shot, and press the shutter button fully down.

AE/AF lock indicator



AF range
finder frame

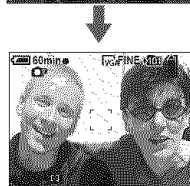

- When you are using AF lock, you can capture an image with the correct focus even if the subject is at the edge of the frame.
- You can carry out the AF lock adjustment process before you press the shutter button fully down.



Setting the distance to the subject

— Focus preset

Mode switch:  

When shooting an image using a previously set distance to the subject, or when shooting a subject through a net or through window glass, it is difficult to get the proper focus in auto focus mode. In these cases, use of the Focus preset is convenient.

Before operation

When shooting still images, set  (Camera) in the menu to other than [Auto] or  (Magnifying glass mode) (pages 43 and 102).

Control button

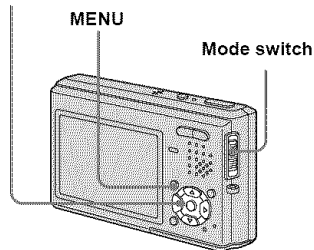

1 Set the mode switch to or .

2 Press MENU.

The menu appears.

3 Select (Focus) with / , then select the distance to the subject with / .

You can select from the following distance settings.

0.5m, 1.0m, 3.0m, 7.0m, ∞ (unlimited distance)

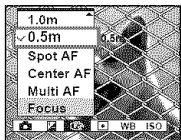

To return to auto focus mode

Select [Multi AF], [Center AF] or [Spot AF] in step **3**.

- Focal point information may not show the exact distance.
- When (Camera) in the menu is set to (Landscape mode) or (Fireworks mode), the focus preset is restricted to ∞ (unlimited distance).

Adjusting the exposure

— EV adjustment

Mode switch: /

You can manually change the exposure set by the camera. This function lets you obtain the proper exposure when the contrast (difference between bright and dark) between the subject and the background is extremely large. You can select values ranging from +2.0EV to -2.0EV in steps of 1/3EV.

Before operation

When shooting still images, set (Camera) in the menu to other than [Auto] (pages 43 and 102).

Control button

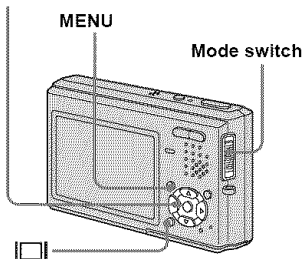

1 Set the mode switch to or .

2 Press MENU.

The menu appears.

3 Select (EV) with / .

The value of the exposure adjustment is displayed.

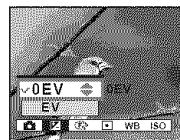

4 Select the desired exposure value.

Select the value with / . Adjust the exposure value while checking the brightness of the background.

To reactivate auto exposure



Select [0EV] in step **4**.

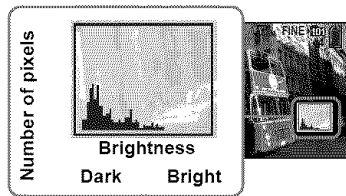

- If a subject is being shot in extremely bright or dark conditions, or the flash is used, the exposure adjustment may not be effective.

Displaying a histogram

A histogram is a graph showing the brightness of an image. The horizontal axis shows the brightness, and the vertical axis shows the number of pixels. The graph display indicates a dark image when skewed to the left side, and a bright image when skewed to the right side. The histogram is useful to check the exposure during recording and playback when the screen is difficult to see.



- 1 Set the mode switch to .
- 2 Press  to display the histogram.
- 3 Press MENU.
The menu appears.
- 4 Adjust the exposure based on the histogram.

- The histogram also appears when the  (Camera) in the menu is set to [Auto], but you cannot adjust the exposure.
- The histogram also appears when you press  while playing back a single image (page 35) or during Quick Review (page 24).
- The histogram does not appear in the following cases:
 - During Quick Review of an image recorded in Exposure Bracket mode
 - When using playback zoom
 - When viewing and shooting movies
-  appears in the following cases:
 - When recording in the digital zoom range
 - When the image size is [3:2]
 - When rotating a still image
 - When viewing Multi Burst images
- The histogram before recording represents the histogram of the image displayed on the LCD screen at that time. A difference occurs in the histogram before and after you press the shutter button. When this happens, check the histogram while playing back a single-image or during Quick Review.
In particular a large difference may appear in the following cases:
 - When the flash strobes
 - When [PFX] (PEffect) is set to [Solarize]
 - When the shutter speed is slow or high
- The histogram may not appear for images recorded using other cameras.

Shooting techniques

Normally, the camera automatically sets the exposure. If the image is too dark or too bright as shown below, we recommend that you adjust the exposure value manually with viewing the histogram. When shooting a back-lit subject or a subject against a white (e.g. snowy) background, adjust the exposure toward the + side. When shooting a black subject that fills the screen, adjust the exposure toward the – side.



Underexposed → Adjust toward +



Appropriate exposure

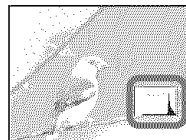

Overexposed → Adjust toward –

Selecting the metering mode

Mode switch:  

The camera measures the brightness to determine the exposure. This function lets you select the following two metering modes to determine which portion of the subject to use for measuring the brightness.

Multi-pattern metering (no indicator)

The image is divided into multiple regions and metering is performed for each region. The camera judges the subject position and background brightness, and determines a well-balanced exposure. The factory setting is multi-pattern metering.

Spot metering ()

Metering is performed for only a portion of the subject. This lets you adjust the exposure to the subject even when the subject is backlit or there is strong contrast between the subject and the background. Position the spot metering cross hair on one point of the subject you want to shoot. To focus on the metering position, setting  (Focus) to [Center AF] is recommended (page 47).

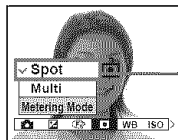





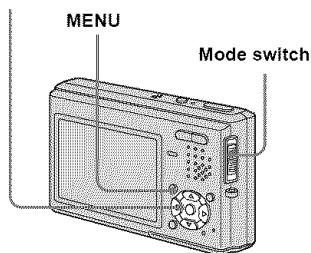

Spot metering cross hair

Before operation

When shooting still images, set  (Camera) in the menu to other than [Auto] (pages 43 and 102).

Control button



- 1** Set the mode switch to  or .
- 2** Press MENU.
The menu appears.
- 3** Select  (Metering Mode) with , then select the desired metering mode with .





Shooting three images with the exposure shifted

— Exposure Bracket

Mode switch: 

The Exposure Bracket function records a series of three images with the exposure values automatically shifted. This lets you select the image with the appropriate exposure after recording when you are unable to shoot good pictures depending on the brightness of the subject.

Before operation

Set  (Camera) in the menu to other than [Auto],  (Magnifying glass mode),  (Twilight mode),  (Twilight portrait mode) or  (Fireworks mode) (pages 43 and 102).

Control button

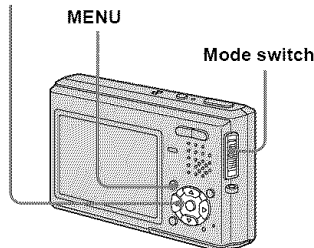

1st image (shifted in the + direction)



2nd image (appropriate exposure for the camera)



3rd image (shifted in the - direction)



1 Set the mode switch to .

2 Press MENU.

The menu appears.

3 Select [Mode] (REC Mode) with \leftarrow/\rightarrow , then select [Exp Brktg] with $\blacktriangle/\blacktriangledown$.

4 Select [BRK] (Bracket Step) with \leftarrow/\rightarrow , then select the desired exposure adjustment value with $\blacktriangle/\blacktriangledown$.

$\pm 1.0\text{EV}$: Shifts the exposure value by plus or minus 1.0EV.

$\pm 0.7\text{EV}$: Shifts the exposure value by plus or minus 0.7EV.

$\pm 0.3\text{EV}$: Shifts the exposure value by plus or minus 0.3EV.

5 Shoot the image.

To return to normal mode

Select [Normal] in step **3**.

- You cannot use the flash in this mode.
- During shooting in this mode, the images are not displayed on the LCD screen. Compose the image before pressing the shutter button.
- The focus and white balance are adjusted for the first image, and these settings are also used for the other images.
- When the exposure is manually adjusted (page 50), the exposure is shifted based on the adjusted brightness.
- The recording interval is approximately 0.36 second.
- If the subject is too bright or too dark, you may be unable to shoot properly with the selected bracket adjustment value.

Adjusting color tones

— White Balance

Mode switch: 

When the white balance is set to Auto, the white balance is automatically set and the overall color balance is adjusted according to the shooting conditions. However, when you shoot under fixed conditions or special lighting conditions, you can manually adjust the white balance.

Auto (no indicator)

Adjusts the white balance automatically. The factory setting is [Auto].

(Daylight)

Shooting outdoors, shooting night scenes, neon signs, fireworks or sunrise, or shooting just before and after sundown

(Cloudy)

Shooting under a cloudy sky

(Fluorescent)

Shooting under fluorescent lighting

(Incandescent)

- Places where the lighting conditions change quickly
- Under bright lighting such as photography studios

WB (Flash)

Adjusts the white balance only to the flash conditions (It does not appear when the mode switch is set to .)

Before operation



When shooting still images, set  (Camera) in the menu to other than [Auto] (pages 43 and 102).

Control button

MENU

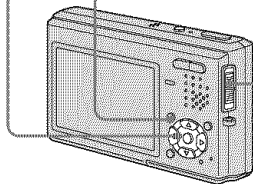

Mode switch



1 Set the mode switch to  or .







2 Press MENU.

The menu appears.

3 Select [WB] (White Bal) with , then select the desired setting with /▼.

To reactivate auto adjustment

Select [Auto] in step **3**.

- Under fluorescent lights that flicker, the white balance adjustment function may not work correctly even though you select .
- When the flash strobes, the manual setting is canceled, and the image is recorded in [Auto] mode (except in WB mode).
- The available White Balance settings are limited as follows according to the  (Camera) setting in the menu:
 -  (Twilight Portrait mode): [Auto] or WB (Flash) only
 -  (Fireworks mode):  (Daylight) only

Shooting techniques

The subject coloring is affected by the lighting conditions. For example, the entire image appears blue under sunlight in the summer, and white items gain a reddish tint under incandescent light bulbs, etc. The human eye can resolve these problems, but digital still cameras cannot recognize the correct colors without adjustments. Normally, the camera makes these adjustments automatically, but if recorded image colors appear unnatural, we recommend that you adjust the white balance.



Adjusting the flash level

— Flash Level

Mode switch: 

You can adjust the amount of flash light.

Before operation

Set  (Camera) in the menu to other than [Auto],  (Twilight mode) or  (Fireworks mode) (pages 43 and 102).

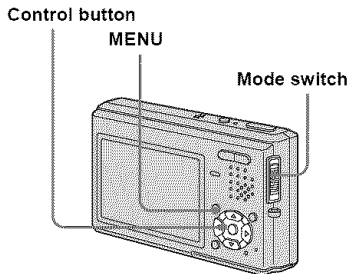

- 1 Set the mode switch to .
- 2 Press MENU.
The menu appears.
- 3 Select \pm (Flash Level) with \blacktriangleleft / \blacktriangleright , then select the desired setting with \blacktriangleup / \blacktriangledown .
High: Makes the flash level higher than normal.
Normal: Normal setting.
Low: Makes the flash level lower than normal.

- You may not be able to shoot with the set flash level depending on the shooting conditions.

Shooting images continuously

— Burst

Mode switch: 

This mode is used for continuous shooting. Each time you press and hold the shutter button in this mode, the camera records maximum four images in succession.

Speed priority burst ()





The images are shot with a short interval (approx. 0.33 second). During shooting in this mode, the images are not displayed on the LCD screen. Compose the image before pressing the shutter button.

Framing priority burst ()

Shooting is performed while displaying the images on the LCD screen. The shooting interval (approx. 0.36 second) becomes longer than speed priority burst.

- When a “Memory Stick Duo” becomes full, shooting stops even if you continue to hold down the shutter button.

Before operation

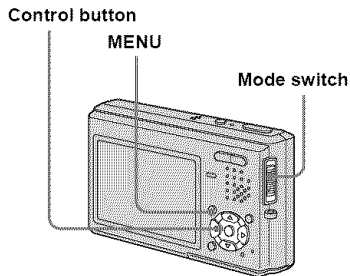

Set  (Camera) in the menu to other than  (Magnifying glass mode),  (Twilight mode),  (Twilight portrait mode) or  (Fireworks mode) (pages 43 and 102).



1 Set the mode switch to .

2 Press MENU.

The menu appears.

3 Select [Mode] (REC Mode) with , then select from [Speed Burst] or [Framing Burst] with .

4 Shoot the image.

You can also shoot only two or three images by releasing the shutter button partway.

When the message “Recording” disappears, you can shoot the next image.

To return to normal mode

Select [Normal] in step **3**.

- You cannot use the flash in this mode.
- When recording with the self timer, a series of four images are recorded each time you press the shutter button.





Shooting in Multi Burst mode

— Multi Burst

Mode switch: 

This mode records 16 frames in succession each time you press the shutter button. This is convenient for checking your form in sports, for example.

Before operation

Set  (Camera) in the menu to other than  (Magnifying glass mode),  (Twilight mode),  (Twilight portrait mode) or  (Fireworks mode) (pages 43 and 102).

Control button

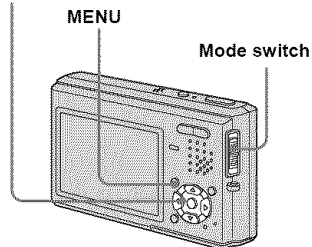

1 Set the mode switch to .

2 Press MENU.

The menu appears.

- 3** Select [Mode] (REC Mode) with ◀/▶, then select [Multi Burst] with ▲/▼.

- 4** Select [M] (Interval) with ◀/▶, then select the desired frame interval with ▲/▼.

You can choose the frame interval from [1/7.5], [1/15] or [1/30].

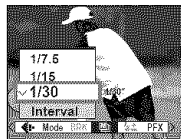

- 5** Shoot the image.

A continuous burst of 16 frames are recorded within a single still image (image size 1M).

- You cannot use the following functions in Multi Burst mode:
 - Smart zoom
 - Flash
 - Inserting the date and time
- When [Camera] (Camera) in the menu is set to [Auto], the frame interval is fixed to [1/30].
- See page 64 to play back Multi Burst images using this camera.
- For the number of images that can be recorded in Multi Burst mode, see page 100.

Shooting still images for e-mail

— E-Mail

Mode switch: 

In E-mail mode, a small-size image (320×240) that is suitable for e-mail transmission is also recorded at the same time as recording a normal still image. (See page 20 for the normal still image sizes.)

Control button

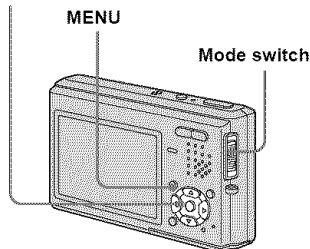

- 1** Set the mode switch to .
- 2** Press MENU.
The menu appears.
- 3** Select [Mode] (REC Mode) with ◀/▶, then select [E-Mail] with ▲/▼.

- 4** Shoot the image.

When the message “Recording” disappears, you can shoot the next image.

To return to normal mode

Select [Normal] in step **3**.

- For instructions on how to attach images to an e-mail message, consult the User's Manual for your e-mail software.
- For the number of images you can record in E-mail mode, see page 100.

Shooting still images with audio files

— Voice

Mode switch: 

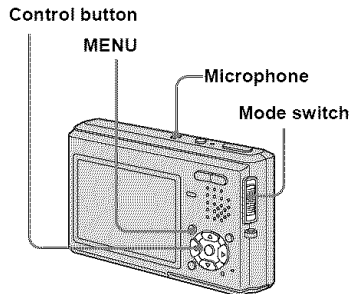

In Voice mode, an audio track is also recorded at the same time as recording a normal still image.



1 Set the mode switch to .

2 Press MENU.

The menu appears.

3 Select [Mode] (REC Mode) with , then select [Voice] with .

4 Shoot the image.

If you press and release the shutter button, sound is recorded for five seconds.

If you hold down the shutter button, sound is recorded until you release the shutter button for up to 40 seconds.

To return to normal mode

Select [Normal] in step **3**.

- To view images recorded in Voice mode, carry out the same procedure described in “Viewing movies on the LCD screen” (page 71).
- Do not touch the microphone during shooting images in this mode.
- For the number of images you can record in Voice mode, see page 100.

Adding special effects

— Picture Effect

Mode switch:  

You can digitally process images to obtain special effects.

Solarize



The light contrast is clearer and the picture looks like an illustration.

Sepia



The picture is sepia-toned like an old photograph.

Neg.Art





The color and brightness of the picture are reversed as in a negative.

Before operation

When shooting still images, set  (Camera) in the menu to other than [Auto] (pages 43 and 102).

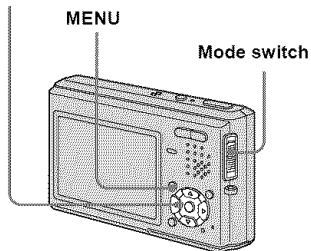
Control button



- 1** Set the mode switch to  or .
- 2** Press MENU.
The menu appears.
- 3** Select [PFX] (P.Effect) with ◀/
▶, then select the desired mode with ▲/▼.
- 4** Shoot the image.

To cancel Picture Effects

Select [Off] in step **3**.

Selecting the folder and playing back images

— Folder

Mode switch: 

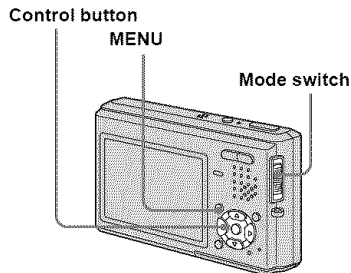

Select the folder that images you want to playback are stored.



1 Set the mode switch to .

2 Press MENU.

The menu appears.

3 Select  (Folder) with , then press .

4 Select the desired folder with

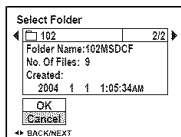

5 Select [OK] with , then press





To cancel the selection

Select [Cancel] in step **5**.

When multiple folders are created in the “Memory Stick Duo”

When the first or last image in the folder is displayed, the following indicators appear on the LCD screen.

: Moves to the previous folder.

: Moves to the next folder.

: Moves to both the previous and next folders.

Single screen



Index (nine-image) screen

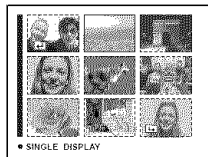

Index (sixteen-image) screen

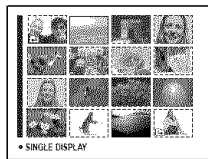

- When no images are stored in the folder, “No file in this folder” appears.
- You can playback images from a last-shot one without selecting the folder.

Enlarging a portion of a still image





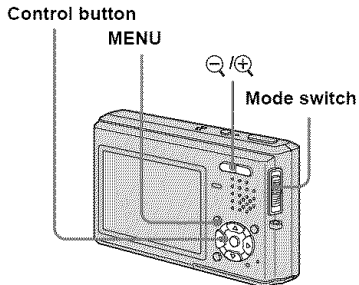



Mode switch: 

You can enlarge a part of an image up to five times the original size. You can also record the magnified image as a new file.



Enlarging an image

— Playback zoom

- 1 Set the mode switch to .
- 2 Display the image to be enlarged with  .
- 3 Press  (playback zoom) to zoom in on the image.
- 4 Select the desired portion of the image with    .



- ▲: To view more of the top of the image
- ▼: To view more of the bottom of the image
- ◀: To view more of the left side of the image
- ▶: To view more of the right side of the image

- 5 Adjust the image size with

  (playback zoom).



To cancel playback zoom

Press .

- You cannot use playback zoom for movies and Multi Burst images.
- If you press  (playback zoom) while a non-enlarged image is displayed, the LCD screen switches to the index screen (page 36).
- You can enlarge the images displayed with the Quick Review function (page 24) by performing steps **3** to **5**.

Recording an enlarged image — Trimming

- 1 Press MENU after playback zoom.

The menu appears.

- 2 Select [Trimming] with \blacktriangleright , then press \bullet .

- 3 Select the image size with $\blacktriangle/\blacktriangledown$, then press \bullet .

The image is recorded, and the image on the LCD screen returns to the normal size after recording.

- The trimmed image is recorded as the newest file in the selected recording folder, and the original image is retained.
- The quality of trimmed images may deteriorate.
- You cannot trim an image size of 3:2.
- You cannot trim images displayed with Quick Review.

Playing back successive images

— Slide Show

Mode switch: \blacktriangleright

You can play back recorded images in order. This function is useful for checking your images or for presentations, etc.

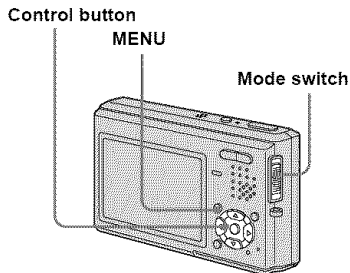

- 1 Set the mode switch to \blacktriangleright .

- 2 Press MENU.

The menu appears.

- 3 Select \blacktriangleright (Slide) with $\blacktriangle/\blacktriangledown$, then press \bullet .

Set the following items with $\blacktriangle/\blacktriangledown/\blacktriangleleft/\blacktriangleright$.

Interval

3 sec/5 sec/10 sec/30 sec/1 min

Image

Folder: Plays back all images in the selected folder.

All: Plays back all images stored in the "Memory Stick Duo."

Repeat

On: Plays back images in a continuous loop.

Off: After all the images have been played back, the slide show ends.

- 4 Select [Start] with $\blacktriangledown/\blacktriangleright$, then press \bullet .

The slide show begins.

To cancel the slide show setting

Select [Cancel] in step 3.

To stop slide show playback

Press ●, select [Exit] with ►, then press ● again.

To skip to the next/previous image during the slide show

Press ► (next) or ◀ (previous).

- The interval setting time is approximate, and may vary according to the playback image size.

Rotating still images

— Rotate

Mode switch: ►

You can rotate an image recorded in portrait orientation and display it in landscape orientation.

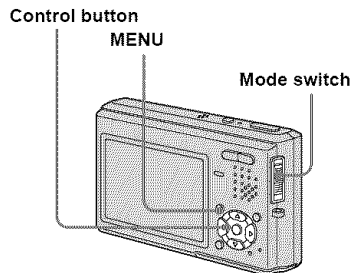
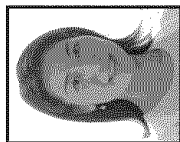

- 1 Set the mode switch to ►, and display the image to rotate.
- 2 Press MENU.
The menu appears.
- 3 Select [Rotate] with ◀/►, then press ●.
- 4 Select ◀/► with ▲, then rotate the image with ◀/►.
- 5 Select [OK] with ▲/▼, then press ●.

To cancel rotation

Select [Cancel] in step **4** or **5**, then press ●.

- You cannot rotate protected images, movies and Multi Burst images.
- You may not be able to rotate images shot with other cameras.
- When viewing images on a computer, the image rotation information may not be reflected depending on the application software.

Playing back images shot in Multi Burst mode

Mode switch: ▶

You can play back Multi Burst images continuously or play them back frame by frame. This function is used for checking the image.

Control button

MENU

Mode switch

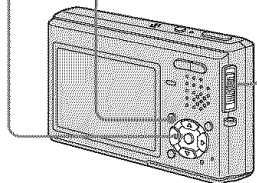

- When Multi Burst images are played back on a computer or on a camera without the Multi Burst function, the 16 frames you shot will be displayed at the same time as part of one image.
- You cannot cut the Multi Burst image.

Playing back continuously

- 1** Set the mode switch to ▶.
- 2** Select the Multi Burst image with ◀/▶.

The selected Multi Burst image is played back continuously.





To pause playback

Press ●. To resume playback, press ● again. The playback starts from the frame displayed on the LCD screen.

Playing back frame by frame

1 Set the mode switch to .

2 Select the Multi Burst image with / .



The selected Multi Burst image is played back continuously.



3 Press  when the desired frame is displayed.

“Step” appears.



4 Advance the frame with / .

: A next frame is displayed. When you keep and press , the frame advances.



: A previous frame is displayed. When you keep and press , the frame advances in the reverse direction.

To return to the normal playback

Press  in step **4**. The playback starts from the frame displayed on the LCD screen.

To delete shot images

When using this mode, you cannot delete only certain frames. When you delete images, all 16 of the frames are deleted at the same time.

- 1 Display the desired Multi Burst image to delete.
- 2 Press  /  (Delete).
- 3 Select [Delete], then press . All of the frames are deleted.

Protecting images

— Protect

Mode switch: 



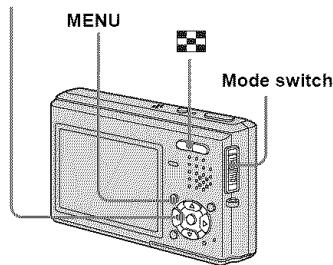

This function protects images against accidental erasure.

Control button



- Note that when you format a "Memory Stick Duo," even protected images are deleted and cannot be restored.



In single-image mode

- 1 Set the mode switch to .
- 2 Display the image you want to protect with .
- 3 Press MENU.
- 4 Select  (Protect) with , then press .

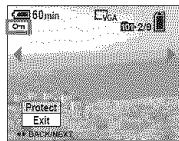

The menu appears.

The displayed image is protected. The  (protect) indicator appears on the image.





- 5 To continue and protect other images, select the desired image with , then press .









To cancel the protection

Press  again in step **4** or **5**. The  indicator disappears.

In index (nine-image/ sixteen-image) mode

- 1 Set the mode switch to , then press  (Index) to display the index (nine-image) screen.

Press  (Index) twice to display a sixteen-image index screen.

- 2 Press MENU.
 - 3 Select , then press .
 - 4 Select [Select] with , then press .
 - 5 Select the image you want to protect with /, then press .
- The green  indicator appears on the selected image.

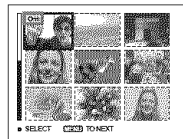

- 6 Repeat step **5** to protect other images.

7 Press MENU.

8 Select [OK] with **▶**, then press **●**.

The **⏏** indicator turns white. The selected images are protected.

To exit the Protect function

Select [Cancel] in step **4** or select [Exit] in step **8**, then press **●**.

To cancel individual protection

Select the image to be unprotected with **▲/▼/◀/▶**, then press **●** in step **5**. The **⏏** indicator turns gray. Repeat this operation for all images that are to be unprotected. Press MENU, select [OK], and then press **●**.

To protect all images in the folder

Select [All In This Folder] in step **4**, and press **●**. Select [On], then press **●**.

To cancel all protection of all images in the folder

Select [All In This Folder] in step **4**, and press **●**. Select [Off], then press **●**.

Changing image size

— Resize

Mode switch: **▶**

You can change the image size of a recorded image, and save it as a new file.

You can resize to the following sizes:

5M, 3M, 1M, VGA

The original image is retained even after resizing.

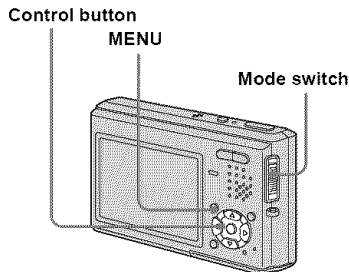

1 Set the mode switch to **▶**.

2 Display the image you want to resize with **◀/▶**.

3 Press MENU.

The menu appears.

4 Select **◻◻◻◻** (Resize) with **◀/▶**, then press **●**.

5 Select the desired size with **▲/▼**, then press **●**.

The resized image is recorded in the recording folder as the newest file.

To cancel resizing

Select [Cancel] in step **5**.

- You cannot change the size of movies or Multi Burst images.
- When you change from a small size to a large size, the image quality deteriorates.
- You cannot resize to an image size of 3:2.
- When you resize a 3:2 image, the upper and lower black portions will be displayed on the image.

Choosing images to print

— Print (DPOF) mark





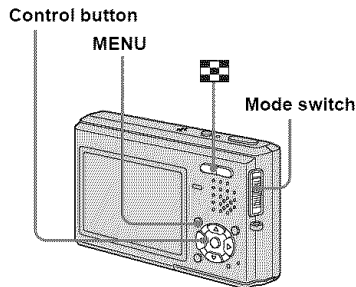

Mode switch: 

You can use your camera to mark still images that you want to have printed. This function is convenient when you have images printed at a shop that supports the DPOF (Digital Print Order Format) standard or using a printer that conforms to the DPOF standard.







- You cannot mark movies.
- In E-mail mode, a print (DPOF) mark is marked on the normal size image that is recorded at the same time.
- When you mark images shot in Multi Burst mode, all the images are printed on one image divided into 16 frames.
- You cannot set the number of prints.

In single-image mode

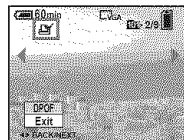

- 1** Set the mode switch to .
- 2** Display the image you want to mark with  .
- 3** Press MENU.
The menu appears.
- 4** Select DPOF (DPOF) with  , then press .

The  mark is marked on the displayed image.





- 5** To continue and mark other images, display the desired image with  , then press .

To unmark the  mark

Press  again in step **4** or **5**. The  mark disappears.



In index (nine-image/ sixteen-image) mode



- 1 Set the mode switch to , then press  (Index) to display the index (nine-image) screen.

Press  (Index) twice to display a sixteen-image index screen.





- 2 Press MENU.

The menu appears.

- 3 Select DPOF (DPOF) with , then press .

- 4 Select [Select] with , then press .

- When marking  marks, you cannot select [All In This Folder].



- 5 Select the image you want to mark with //, then press .

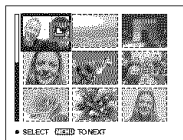

The green  mark appears on the selected image.







- 6 Repeat step 5 to mark other images.

- 7 Press MENU.



- 8 Select [OK] with , then press .

The  mark turns white. The  mark setting is completed.

To unmark marks

Select the images to be unmarked with // in step 5, then press .

To unmark all the marks in the folder

Select [All In This Folder] in step 4, then press . Select [Off], then press .

To exit the mark function

Select [Cancel] in step 4, or select [Exit] in step 8.



Shooting movies

Mode switch: 

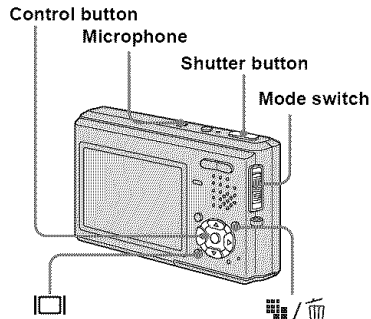

You can shoot movies with sound using your camera.



1 Set the mode switch to .

2 Press  /  (Image Size).

The Image Size setup appears.

3 Select the desired size with  / .

You can choose from [640(Fine)], [640(Standard)] and [160].

- [640(Fine)] can be recorded only on "Memory Stick PRO Duo."

4 Press the shutter button fully down.

"REC" appears on the LCD screen and the camera starts recording the image and sound.

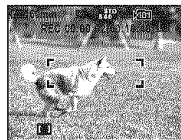

Recording stops when the "Memory Stick Duo" is full.

5 Press the shutter button fully down again to stop recording.

Indicators during shooting

The screen indicators are not recorded. Each time you press , the status of the LCD screen changes as follows: Indicators off → LCD backlight off → Indicators on. A histogram is not displayed. For a detailed description of the indicators, see page 115.

Shooting close-ups (Macro)

Set the mode switch to  and follow the procedure on page 27.

Using the self-timer

Set the mode switch to  and follow the procedure on page 28.

- Do not touch the microphone during shooting movies.
- You cannot use the following functions during shooting movies:
 - Changing the zoom scale
 - Flash
 - Inserting the date and time
- When you set the image size to [640(Fine)] while connecting the A/V connecting cable to A/V OUT (MONO) jack, the subject does not appear on the LCD screen. The LCD screen turns blue.
- For the recording time in each movie mode, see page 101.



Viewing movies on the LCD screen

Mode switch: 

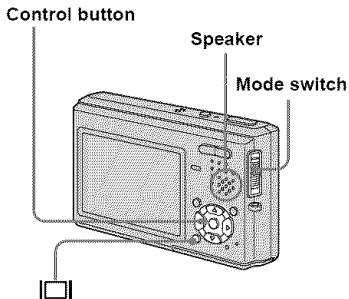
You can view movies on the LCD screen with sound from the speaker.



1 Set the mode switch to .

2 Select the desired movie with  .

Movies with the image size [640(Fine)] or [640(Standard)] are displayed on the full screen.



Movies with the image size [160] are displayed a size smaller.

3 Press .

The movie and sound are played back. During playback,  (Playback) appears on the LCD screen.





Playback bar



To stop playback

Press  again.

To adjust the volume

Press   to adjust the volume.

To advance or rewind the movie

Press   during playback.

To return to the normal playback, press .

Indicators during viewing movies

Each time you press , the status of the screen changes as follows: Indicators off → LCD backlight off → Indicators on.

A histogram is not displayed.

For a detailed description of the indicators, see page 117.

- The procedure for viewing movies on a TV is the same as that for viewing still images (page 37).
- The movies recorded using earlier Sony models may be also displayed a size smaller.

Deleting movies

Mode switch: 





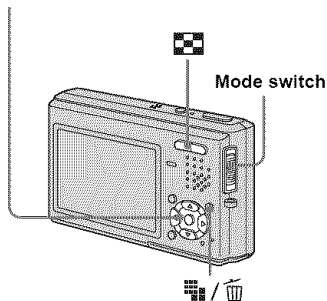



You can delete unwanted movies.

Control button



- You cannot delete protected movies.
- Note that you cannot restore deleted movies.











In single-image mode

- 1** Set the mode switch to .
- 2** Display the movie you want to delete with / .
- 3** Press  /  (Delete).
The movie has not yet been deleted at this point.
- 4** Select [Delete] with , then press .
- 5** To continue and delete other movies, display the movie you want to delete with / , and repeat step **4**.

To cancel deletion

Select [Exit] in step **4** or **5**.

In index (nine-image/ sixteen-image) mode

- 1** Set the mode switch to , then press  (Index) to display an index (nine-image) screen.
Press  (Index) twice to display a sixteen-image index screen.
- 2** Press  /  (Delete).
The movie has not yet been deleted at this point.
- 3** Select [Select] with , then press .
- 4** Select the movie you want to delete with / , then press .

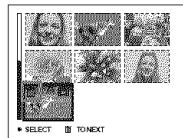

The green  (Delete) indicator appears on the selected movie.



The movie has not yet been deleted at this point.

- 5** Repeat step **4** to delete other movies.

6 Press  (Delete).





7 Select [OK] with , then press .

The message “Access” appears, and the movies have been deleted.

To cancel deletion

Select [Exit] in step **3** or **7**.

To delete all images in the folder

Select [All In This Folder] in step **3**, then press . Select [OK] with , then press . To cancel deletion, select [Cancel] with , then press .

Editing movies

Mode switch: 

You can cut movies, or delete unnecessary portions of movies. This is the recommended mode to use when the “Memory Stick Duo” capacity is insufficient, or when you attach movies to your e-mail messages.

The file numbers assigned when movies are cut

The cut movies are assigned new numbers and recorded as the newest files in the selected recording folder. The original movie is deleted, and that number is skipped.

Control button

MENU

Mode switch

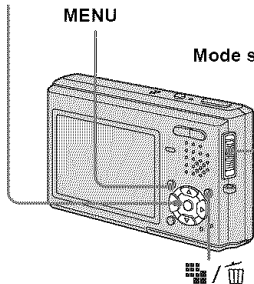

<Example> Cutting a movie numbered 101_0002

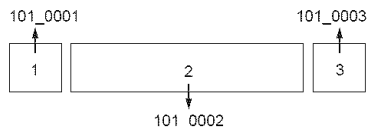

1. Cutting scene A.

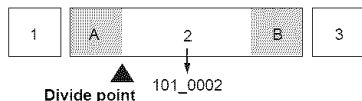

2. Cutting scene B.

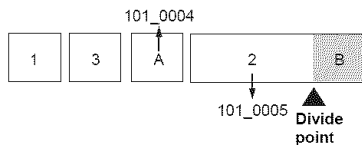

3. Deleting scenes A and B if they are unnecessary.

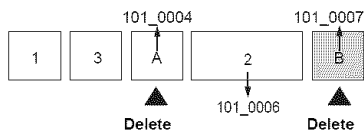

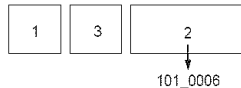

4. Only the desired scenes remain.







Cutting movies

1 Set the mode switch to .

2 Select the movie you want to cut with / .

3 Press MENU.

The menu appears.





4 Select  (Divide) with , then press . Next, select [OK] with , then press .

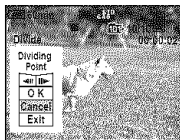

The playback of the movie starts.



5 Decide on a cutting point.

Press  at the desired cutting point.



When you want to adjust the cutting point, use [/ / ] (frame forward/rewind) and adjust the cutting point using / . If you want to change the cutting point, select [Cancel]. The playback of the movie starts again.

6 When you have decided on a cutting point, select [OK] with / , and press .

7 Select [OK] with , then press .

The movie is cut.

To cancel cutting

Select [Exit] in step **5** or **7**. The movie appears on the LCD screen again.

- You cannot cut the following images.
 - Still images
 - Movie files not long enough to cut
 - Protected movie files
- You cannot restore files once you cut them.
- The original movie is deleted when you cut it.
- The cut movies are recorded as the newest files in the selected recording folder.



Deleting unnecessary portions of movies

1 Cut an unnecessary portion of a movie (page 74).

2 Display the portion of the movie you want to delete.

3 Press /  (Delete).

The movie has not yet been deleted at this point.

4 Select [Delete] with , then press .

The movie currently displayed on the LCD screen is deleted.

- Note that you cannot restore deleted portions of movies.

Copying images to your computer

— For Windows users

Recommended computer environment

OS: Microsoft Windows 98, Windows 98SE, Windows 2000 Professional, Windows Millennium Edition, Windows XP Home Edition or Windows XP Professional

The above OS must be installed at the factory. Operation is not assured in an environment upgraded to the operating systems described above or in a multi-boot environment.

CPU: MMX Pentium 200 MHz or faster

USB connector: Provided as standard

Display: 800 × 600 dots or more
High Color (16-bit color, 65,000 colors) or more

- This camera conforms to USB 2.0.
- Use with a USB 2.0 (High-Speed USB) compatible computer environment allows high-speed data transfer.
- If you connect two or more USB equipment to a single computer at the same time, some equipment, including your camera, may not operate depending on the type of USB equipment.

- Operations are not guaranteed when using a USB hub.
- Operations are not guaranteed for all the recommended computer environments mentioned above.

USB mode

There are two modes for connecting to a computer, [Normal] and [PTP]* modes. The factory setting is the [Normal] mode. This section describes the [Normal] mode as an example.

* Compatible only with Windows XP. When connected to a computer, only the data in the folder selected by the camera is copied to the computer. To select a folder, perform the procedure on page 60.

Communication with your computer

When your computer resumes from the suspend or sleep mode, communication between your camera and your computer may not recover at the same time.

When a USB connector is not provided on your computer

When neither a USB connector nor a “Memory Stick” slot is provided, you can copy images using an additional device. See the Sony Website for details.
<http://www.sony.net/>

Contents of the CD-ROM

■ USB Driver

This driver is needed in order to connect the camera to a computer.

- When using Windows XP, you need not install the USB driver.

■ Image Transfer

This application is used to easily transfer images from the camera to a computer.

■ ImageMixer

This application is used to display and edit images that are stored in a computer.

- The required operations may differ depending on your OS.
- **Close down all applications running on the computer before installing the USB driver and application.**
- When using Windows XP or Windows 2000, log on as Administrators.
- The display settings should be 800 × 600 dots or more and High Color (16-bit color, 65,000 colors) or more. When set to less than 800 × 600 dots or 256 colors or less, the model selection screen does not appear.



Installing the USB driver

When using Windows XP, you need not install the USB driver.

Once the USB driver is installed, you need not install the USB driver again.

- 1 Start up your computer, and insert the CD-ROM (supplied) into the CD-ROM drive.

Do not connect your camera to your computer at this time.

The model selection screen appears. If it does not appear, double-click  (My Computer) →  (ImageMixer) in that order.

- 2 Click [Cyber-shot] on the model selection screen.



The installing menu screen appears.

- 3 Click [USB Driver] on the installing menu screen.



The “InstallShield Wizard” screen appears.

- 4 Click [Next]. When the “Information” screen appears, click [Next].



The USB driver installation starts. When the installation is completed, the screen informs you of completion.

- 5 Click [Yes, I want to restart my computer now], then click [Finish].

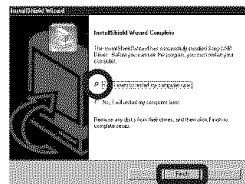

Your computer restarts. Then, you can establish USB connection.

Installing "Image Transfer"

You can use the "Image Transfer" software to copy images to your computer automatically when you connect the camera to your computer with the supplied USB cable.

- 1 Click [Cyber-shot] on the model selection screen.



The installing menu screen appears.

- 2 Click [Image Transfer] on the installing menu screen. Select the desired language, then click [OK].

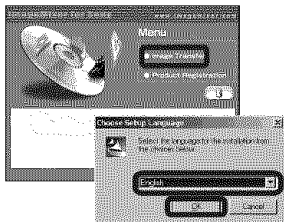

The "Welcome to the InstallShield Wizard for Image Transfer" screen appears.

- This section describes the English screen.

- 3 Click [Next]. When "Licence Agreement" screen appears, click [Yes].

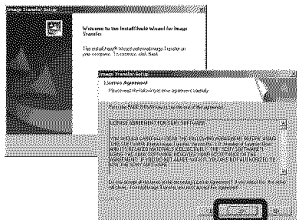

Read the agreement carefully. If you accept the terms of the agreement, proceed with the installation. The "Information" screen appears.

- 4 Click [Next].

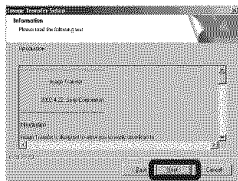

- 5 Select the folder to be installed, then click [Next]. Select the program folder, then click [Next].

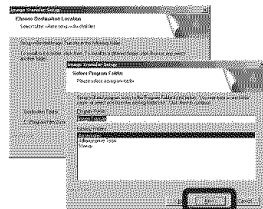

- 6 Confirm if the checkbox is checked on the "Image Transfer Settings" screen, then click [Next].

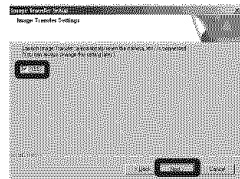

When the installation is completed, the screen informs you of completion.



7 Click [Finish].

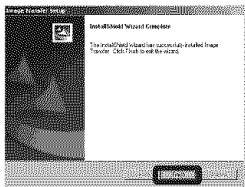

The “InstallShield Wizard” screen closes. If you wish to continue with the installation of “ImageMixer,” click [ImageMixer] on the installing menu screen and then follow the procedure.

- The USB driver is needed in order to use “Image Transfer.” If the necessary driver is not already installed on your computer, a screen that asks if you want to install the driver will appear. Follow the instructions that appear on the screen.

Installing “ImageMixer”

You can use the “ImageMixer Ver. 1.5 for Sony” software to copy, view and edit images, and create video CDs. For details, see the software’s help files.

- 1 Click [ImageMixer] on the installing menu screen. Select the desired language, then click [OK].

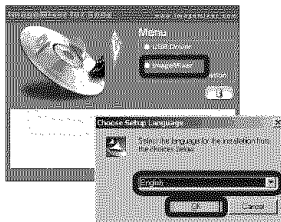

The “Welcome to the InstallShield Wizard” screen appears.

- This section describes the English screen.

- 2 Follow instructions on each succeeding screen.

Install “ImageMixer” according to the screen.

- When you use Windows 2000 or Windows XP, install “WinASPI”.
- If DirectX8.0a or a later version is not installed in your computer, the “Information” screen appears. Follow the procedure on the screen.

- 3 Restart your computer according to the screen.

- 4 Remove the CD-ROM.

Connecting the camera to your computer

- 1 Turn on your computer.
- 2 Insert the “Memory Stick Duo” with the images you want to copy into the camera.
 - For further details on the “Memory Stick Duo,” see page 19.
- 3 Connect the USB cradle (supplied) and the AC Adaptor (supplied), and plug the adaptor into a wall outlet (wall socket).

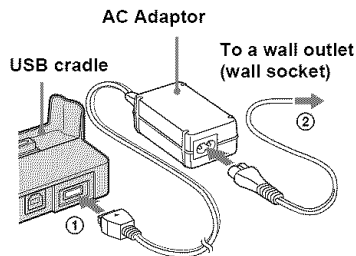

- When you copy images to your computer using the battery pack, battery shutoff may cause copying to fail or data corruption. In addition, power is not supplied from the USB cable, so we recommend that you use the AC Adaptor.

- 4 Connect the USB cable to the Ψ (USB) jack of the USB cradle.

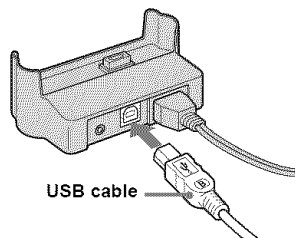

- 5 Connect the USB cable to your computer.

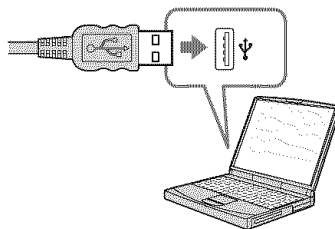

- When you use a desktop computer, we recommend that you connect the USB cable to the USB connector on the rear panel.
- When using Windows XP, the AutoPlay wizard automatically appears on the desktop. Proceed to page 82.

- 6 Connect the camera to the USB cradle and turn on the camera.

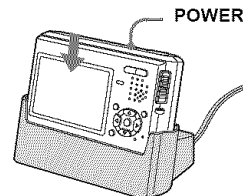

- Make sure the camera is securely connected to the USB cradle.

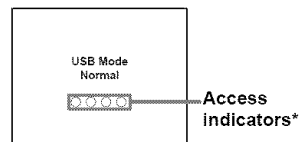

“USB Mode Normal” appears on the LCD screen of the camera. When a USB connection is established for the first time, your computer automatically runs the used program to recognize the camera. Wait for a while.

- * During communication, the access indicators turn red.
- If “USB Mode Normal” does not appear in step 6, confirm that [USB Connect] is set to [Normal] on the Setup screen (page 107).
- **Do not remove the camera from the USB cradle during USB connection, as the image data may be destroyed. To end the USB connection, see the note \blacksquare on page 80.**

❏ Disconnecting the USB cable from your computer, removing the “Memory Stick Duo” from your camera or turning off the power during USB connection

For Windows 2000, Me or XP users

- 1 Double-click  on the taskbar.



Double-click here

- 2 Click  (Sony DSC), then click [Stop].
- 3 Confirm the device on the confirmation screen, then click [OK].
- 4 Click [OK].
Step 4 is unnecessary for Windows XP users.
- 5 Disconnect the USB cable, remove the “Memory Stick Duo” or turn off the power.

For Windows 98 or 98SE users

Confirm that the access indicators (page 79) on the LCD screen are turned white and carry out only step 5 above.

Copying images using “Image Transfer”

— Windows 98/98SE/2000/Me

Connect the camera and your computer with the USB cable and the USB cradle.

“Image Transfer” launches and the images are automatically copied to the computer. When copying is complete, “ImageMixer” automatically launches and images appear.

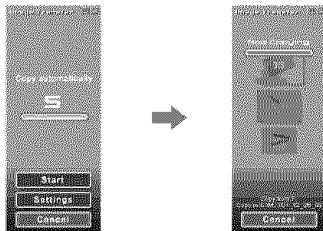

- Normally “Image Transfer” and “Date” folders are created inside the “My Documents” folder, and all of the image files recorded with the camera are copied into these folders.
- You can change the “Image Transfer” settings (page 81).

— Windows XP

Connect the camera and your computer with the USB cable and the USB cradle.

“Image Transfer” starts up automatically and the images are automatically copied to the computer.

Windows XP is set so that the OS AutoPlay Wizard activates.

If you want to cancel the setting, follow the procedure below.

- 1 Click [Start], then click [My Computer].
- 2 Right-click [Sony MemoryStick], then click [Properties].
- 3 Cancel the setting.
 - ① Click [AutoPlay].
 - ② Set [Content type] to [Pictures].
 - ③ Check [Select an action to perform] under [Actions], select [Take no action], then click [Apply].
 - ④ Set [Content type] to [Video files] and proceed step ③. Set [Content type] to [Mixed content] and proceed step ③.
 - ⑤ Click [OK].

The [Properties] screen closes.

The OS AutoPlay Wizard does not start up automatically even if the USB connection is made next time.

Changing "Image Transfer" settings

You can change "Image Transfer" settings. Right-click the "Image Transfer" icon on the taskbar, select [Open Settings]. The settings you can set are as follows: [Basic], [Copy], and [Delete].



Right-click here

When the "Image Transfer" starts, the below window appears.



When you select [Settings] from the above window, you can only change the [Basic] setting.

Copying images without using "Image Transfer"

— Windows 98/98SE/2000/Me

If you do not set to launch "Image Transfer" automatically, you can copy images as following procedure.

1 Double-click [My Computer], then double-click [Removable Disk].

The contents of the "Memory Stick Duo" inserted in your camera appear.

- This section describes an example of copying images to the "My Documents" folder.
- When the "Removable Disk" icon is not shown, see page 82.
- When using Windows XP, see page 82.

2 Double-click [DCIM], then double-click the folder which contains the desired images.

The folder opens.

3 Right-click the image, then click [Copy].

4 Double-click the "My Documents" folder. Right-click the inside of the folder, then click [Paste].

The image files are copied to the "My Documents" folder.



When an image with the same file name exists in the copy destination folder

The overwrite confirmation message appears. When you overwrite the existing image with the new one, the original file data is deleted.

To change the file name

To copy an image file to the computer without overwriting, change the file name to the desired name. However, note that if you change the file name, you may not be able to play back that image with your camera. To play back images with the camera, perform the operation on page 85.

When a removable disk icon is not shown

- 1 Right-click [My Computer], then click [Properties].
The “System Properties” screen appears.
- 2 Display [Device Manager].
 - ① Click [Hardware].
 - ② Click [Device Manager].
- When using Windows 98, 98SE or Me, skip step ①. Click [Device Manager] tab.
- 3 Delete “ Sony DSC” if it appears.
 - ① Right-click [ Sony DSC].
 - ② Click [Uninstall]. (When using Windows 98, 98SE or Me, click [Remove].)
The “Confirm Device Removal” screen appears.
 - ③ Click [OK].
The device is deleted.

Try the USB driver installation again using the CD-ROM (supplied) (page 76).

— Windows XP

Copying images using the Windows XP AutoPlay Wizard

- 1 Make a USB connection (page 79). Click [Copy pictures to a folder on my computer using Microsoft Scanner and Camera Wizard], then click [OK].**

The “Scanner and Camera Wizard” screen appears.

- 2 Click [Next].**

The images stored on the “Memory Stick Duo” are displayed.

- 3 Click the checkbox of images that you do not want to copy to your computer and remove the checkmark, then click [Next].**

The “Picture Name and Destination” screen appears.

- 4 Select a name and destination for your pictures, then click [Next].**

Image copying starts. When the copying is completed, the “Other Options” screen appears.

- 5 Select [Nothing. I'm finished working with these pictures], then click [Next].**

The “Completing the Scanner and Camera Wizard” screen appears.

- 6 Click [Finish].**

The wizard closes.

- To continue copying other images, follow the procedure given under **1** on page 80 to disconnect the USB cable and reconnect it. Then, perform the procedure from step **1** again.

Viewing images on your computer

1 Click [Start] → [My Documents] in that order.

The “My Documents” folder contents are displayed.

- This section describes the procedure for viewing copied images in the “My Documents” folder.
- Except for Windows XP, double-click [My Documents] on the desktop.
- You can use the “ImageMixer Ver. 1.5 for Sony” software to view and edit images on your computer. For details, see the software’s help files.

2 Double-click the desired image file.

The image is displayed.

Image file storage destinations and file names

Image files recorded with your camera are grouped as folders in the “Memory Stick Duo.”

Example: For Windows XP users

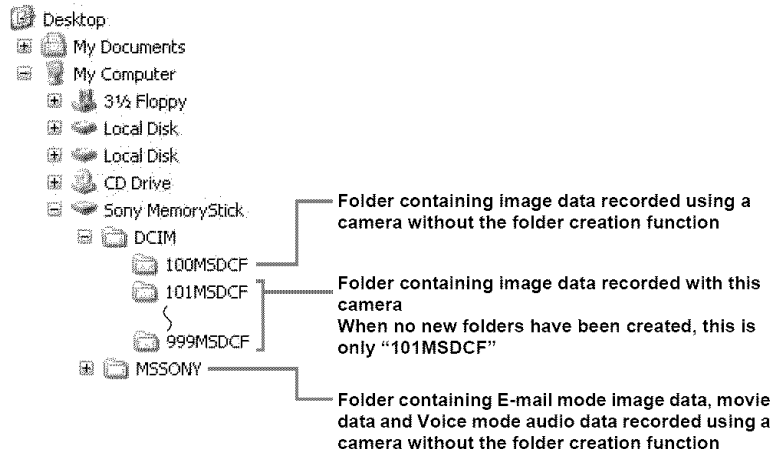

- Data in the “100MSDCF” or “MSSONY” folders is for playback only, and your camera cannot record images in these folders.
- For more information about the folder, see page 45.

Folder	File name	File meaning
101MSDCF up to 999MSDCF	DSC0□□□□.JPG	<ul style="list-style-type: none"> • Still image files shot in <ul style="list-style-type: none"> – Normal mode – Exposure Bracket mode (page 52) – Burst mode (page 55) – Multi Burst mode (page 56) • Still image files recorded simultaneously in <ul style="list-style-type: none"> – E-Mail mode (page 57) – Voice mode (page 58)
	DSC0□□□□.JPE	• Small-size image files shot in E-Mail mode (page 57)
	DSC0□□□□.MPG	• Audio files shot in Voice mode (page 58)
	MOV0□□□□.MPG	• Movie files (page 70)
	MOV0□□□□.THM	• Index image file recorded simultaneously in movie mode (page 70)

- □□□□ stands for any number within the range from 0001 to 9999.
- The numerical portions of the following files are the same.
 - A small-size image file shot in E-Mail mode and its corresponding image file
 - An audio file shot in Voice mode and its corresponding image file
 - A movie file shot in movie mode and its corresponding index image file

Viewing image files once copied to a computer with your camera

When an image file copied to a computer no longer remains in a “Memory Stick Duo,” you can view that image again on your camera by copying the image file in the computer to a “Memory Stick Duo.”

- Step **1** is not necessary when the file name set with your camera has not been changed.
- You may be unable to play back some images depending on the image size.
- When an image file has been processed by a computer or when the image file was recorded using a model other than your camera, playback on your camera is not guaranteed.

1 Right-click the image file, then click [Rename]. Change the file name to “DSC0□□□□.”

Enter a number from 0001 to 9999 for □□□□.

- An extension may be displayed depending on the computer settings. The extension for still images is JPG, and the extension for moving images is MPG. Do not change the extension.

2 Copy the file to the “Memory Stick Duo” folder.

- ① Right-click the image file, then click [Copy].
- ② Select the “DCIM” folder within the [Removable Disk] or [Sony MemoryStick] from [My Computer].
- ③ Right-click the [□□□MSDCF] folder in the “DCIM” folder and click [Paste]. □□□ is a number from 100 to 999.

- When the overwrite confirmation message appears, enter a different number in step **1**.
- When there is no folder, first create a folder with your camera and then copy the image file (page 45).

Copying images to your computer

— For Macintosh users

Recommended computer environment

OS: Mac OS 9.1, 9.2 or Mac OS X (v10.0/v10.1/v10.2)

The above OS must be installed at the factory.

USB connector: Provided as standard

Display: 800 × 600 dots or more
32,000-color mode or more

- If you connect two or more USB equipment to a single computer at the same time, some equipment, including your camera, may not operate depending on the type of USB equipment.
- Operations are not guaranteed when using a USB hub.
- Operations are not guaranteed for all the recommended computer environments mentioned above.

USB mode

There are two modes for connecting to a computer, [Normal] and [PTP]* modes. The factory setting is the [Normal] mode. This section describes the [Normal] mode as an example.

* Compatible only with Mac OS X. When connected to a computer, only the data in the folder selected by the camera is copied to the computer. To select a folder, perform the procedure on page 60.

Communication with your computer

When your computer resumes from the suspend or sleep mode, communication between your camera and your computer may not recover at the same time.

When a USB connector is not provided on your computer

When neither a USB connector nor a “Memory Stick” slot is provided, you can copy images using an additional device. See the Sony Website for details.
<http://www.sony.net/>

1 Connecting your camera to your computer

For details, see page 79.

Disconnecting the USB cable from your computer, removing the “Memory Stick Duo” from your camera or turning off the power during a USB connection

Drag and drop the drive icon or the “Memory Stick” icon to the “Trash” icon, then remove the USB cable or “Memory Stick Duo” or turn off the power.

- If you are using Mac OS X v10.0, remove the USB cable, etc., after you have turned your computer off.

2 Copying images

- 1 Double-click the newly recognized icon on the desktop.
The contents of the “Memory Stick Duo” inserted in your camera appear.
 - 2 Double-click [DCIM].
 - 3 Double-click the folder containing the desired image file.
 - 4 Drag and drop the image files to the hard disk icon.
The image files are copied to your hard disk.
- See pages 83 and 84 for details about the image file storage destinations and file names.

3 Viewing the images on your computer

- 1 Double-click the hard disk icon.
 - 2 Double-click the desired image file in the folder containing the copied files. The image file opens.
- **Close down all applications running on the computer before installing the application.**
 - You can use the “ImageMixer Ver. 1.5 for Sony” software to copy, view and edit images, and create video CDs. See the operation manual supplied with the CD-ROM for details about the installation method, or see the software’s help files for the operation method.
 - When images cannot be displayed, increase the virtual memory capacity of the computer.
 - “ImageMixer” is not compatible with Mac OS X.
 - “Image Transfer” cannot be used with Macintosh.

For Mac OS X users

If the “There is no application available to open the document “DSC0□□□□.JPE”.” screen appears when you click an E-mail mode image file, make the following setting.

The screen display may differ depending on the version.

- 1 Click [Choose Application...] at the “There is no application available to open the document “DSC0□□□□.JPE”.” screen.
- 2 Change “Show” from [Recommended Applications] to [All Applications].
- 3 Select [QuickTime Player] from the displayed list of applications, and click [Open].

Troubleshooting

If you experience trouble with your camera, try the following solutions.

- 1 First check the items on the tables below.
If code displays "C:□□:□□" appear on the LCD screen, the self-diagnosis display function is working (page 99).

- 2 Should your camera still not work properly, press the RESET button on the lower right side of the control button using a fine-tipped object, then turn on the power again. (All the settings including date and time are cleared.)

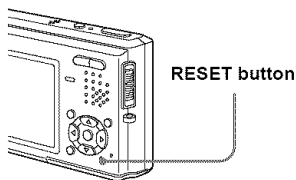







- 3 Should your camera still not work properly, consult your Sony dealer or local authorized Sony service facility.

Battery pack and power











Symptom	Cause	Solution
You cannot charge the battery pack.	<ul style="list-style-type: none"> • The camera is turned on. • The battery pack is not installed correctly. 	<ul style="list-style-type: none"> → Turn the camera off (page 16). → Install the battery pack correctly (page 11).
The $\frac{1}{2}$/CHG lamp flashes when charging a battery pack.	<ul style="list-style-type: none"> • The battery pack is not installed correctly. • The battery pack has malfunctioned. 	<ul style="list-style-type: none"> → Install the battery pack correctly (page 11). → Consult your Sony dealer or local authorized Sony service facility.
The $\frac{1}{2}$/CHG lamp does not light up when charging a battery pack.	<ul style="list-style-type: none"> • The AC Adaptor is disconnected. • The AC Adaptor has malfunctioned. • The battery pack is not installed correctly. • The battery pack is completely charged. • The camera is not properly installed to the USB cradle. 	<ul style="list-style-type: none"> → Properly connect the AC Adaptor (page 11). → Consult your Sony dealer or local authorized Sony service facility. → Install the battery pack correctly (page 11). — → Properly install the camera (page 10).

























Symptom	Cause	Solution
The battery remaining indicator is incorrect, or sufficient battery remaining indicator is displayed but the power runs out soon.	<ul style="list-style-type: none"> You have used the camera for a long time in an extremely hot or an extremely cold location. A deviation has occurred in the remaining battery time. The battery pack is discharged. The battery pack is dead (page 111). 	<ul style="list-style-type: none"> → See page 111. → Fully discharge and then charge the battery pack so that the battery remaining indicator functions correctly (page 13). → Install a charged battery pack (page 11). → Replace the battery pack with a new one.
The battery pack runs down too quickly.	<ul style="list-style-type: none"> You are shooting/viewing images in an extremely cold location. The battery terminal is dirty. The battery pack is dead (page 111). 	<ul style="list-style-type: none"> → Clean the battery terminal with a cotton swab, etc., and charge the battery pack. → Replace the battery pack with a new one.
You cannot turn on the camera.	<ul style="list-style-type: none"> The battery pack is not installed correctly. The AC Adaptor is disconnected. The AC Adaptor has malfunctioned. The battery pack is discharged. The battery pack is dead (page 111). The camera is not properly installed to the USB cradle. 	<ul style="list-style-type: none"> → Install the battery pack correctly (page 11). → Properly connect the AC Adaptor (page 15). → Consult your Sony dealer or local authorized Sony service facility. → Install a charged battery pack (page 11). → Replace the battery pack with a new one. → Properly install the camera (page 10).
The power turns off suddenly.	<ul style="list-style-type: none"> If you do not operate the camera for about three minutes when using a battery pack, the camera turns off automatically to prevent wearing down the battery (page 16). The battery pack is discharged. The camera is not properly installed to the USB cradle. 	<ul style="list-style-type: none"> → Turn on the camera again (page 16) or use the AC Adaptor (page 15). → Install a charged battery pack (page 11). → Properly install the camera (page 10).

Shooting still images/movies

Symptom	Cause	Solution
The LCD screen is not turned on even when the power is turned on.	<ul style="list-style-type: none"> The LCD backlight is turned off with  in the dark place. 	<ul style="list-style-type: none"> → Turn on the LCD backlight with  (page 25).
The subject is not visible on the LCD screen.	<ul style="list-style-type: none"> The mode switch is not set to  or . 	<ul style="list-style-type: none"> → Set it to  or  (pages 22 and 70).







Symptom	Cause	Solution
The LCD screen turns blue and the subject does not appear when recording movies.	<ul style="list-style-type: none"> The image size is set to [640(Fine)] while an A/V connecting cable is connected to the A/V OUT (MONO) jack. 	<ul style="list-style-type: none"> → Disconnect the A/V connecting cable. → Set the image size to other than [640(Fine)].
The image is out of focus.	<ul style="list-style-type: none"> The subject is too close. When shooting still images,  (Camera) in the menu is set to  (Magnifying glass mode),  (Twilight mode),  (Landscape mode) or  (Fireworks mode). The focus preset function is selected. 	<ul style="list-style-type: none"> → Use close-up (Macro) function and set the lens position farther away from the subject than the shortest shooting distance (page 27). Or, set  (Camera) in the menu to  (Magnifying glass mode) and focus within the range of 1 cm to 20 cm (13/32 inch to 7 7/8 inches) from the subject (page 32). → Set it to other settings (page 32). → Cancel the function (page 49).
Zoom does not function.	<ul style="list-style-type: none"> You cannot change the zoom scale when shooting movies. 	—
Optical zoom does not function.	<ul style="list-style-type: none"> When shooting still images,  (Camera) in the menu is set to  (Magnifying glass mode). 	<ul style="list-style-type: none"> → Set it to other settings (page 32).
Digital zoom does not function.	<ul style="list-style-type: none"> [Digital Zoom] is set to [Off] on the Setup screen. The image size is set to [5M] or [3:2] (only when using the smart zoom). You are shooting in Multi Burst mode (only when using the smart zoom). 	<ul style="list-style-type: none"> → Set [Digital Zoom] to [Smart] or [Precision] (pages 44 and 106). → Set image size to other settings except [5M] and [3:2] (page 20). → Set [Digital Zoom] to [Precision] (pages 44 and 106).
The image is too dark.	<ul style="list-style-type: none"> You are shooting a subject with a light source behind the subject. The brightness of the LCD screen is too low. The LCD backlight is turned off. 	<ul style="list-style-type: none"> → Adjust the exposure (page 50). → Adjust the brightness of the LCD screen (pages 44 and 107). → Turn on the LCD backlight with  (page 25).
The image is too bright.	<ul style="list-style-type: none"> You are shooting a spotlighted subject in a dark location such as on a stage. The brightness of the LCD screen is too bright. 	<ul style="list-style-type: none"> → Adjust the exposure (page 50). → Adjust the brightness of the LCD screen (pages 44 and 107).
Vertical streaks appear when you are shooting a very bright subject.	<ul style="list-style-type: none"> The smear phenomenon is occurring. 	<ul style="list-style-type: none"> → This is not a malfunction.

Symptom	Cause	Solution
Noise appears in the image when you view the LCD screen in a dark place.	<ul style="list-style-type: none"> The camera is functioning to increase the visibility of the LCD screen by temporarily brightening the image under conditions of low illumination. 	<ul style="list-style-type: none"> → There is no effect on the recorded image.
Your camera cannot record images.	<ul style="list-style-type: none"> No “Memory Stick Duo” has been inserted. The “Memory Stick Duo” is full. You are using a “Memory Stick Duo” with a write-protect switch, and the write-protect switch is set to the LOCK position. You cannot record images while charging the flash. The mode switch is not set to  when shooting a still image. The mode switch is not set to  when shooting a movie. The image size is set to [640(Fine)] when recording movies. 	<ul style="list-style-type: none"> → Insert a “Memory Stick Duo” (page 19). → Delete unnecessary images (pages 39 and 72). → Change the “Memory Stick Duo.” → Set it to the recording position (page 109). — → Set it to  (page 22). → Set it to  (page 70). → Insert a “Memory Stick PRO Duo” (pages 70 and 109). → Set the image size to other than [640(Fine)].
The flash does not work.	<ul style="list-style-type: none"> The mode switch is not set to . The flash is set to . When shooting still images,  (Camera) in the menu is set to  (Twilight mode) or  (Fireworks mode).  (Camera) in the menu is set to  (Magnifying glass mode),  (Landscape mode),  (Snow mode),  (Beach mode) or  (High-speed shutter mode). [Mode] (REC Mode) in the menu is set to [Multi Burst], [Exp Brktg], [Speed Burst] or [Framing Burst]. 	<ul style="list-style-type: none"> → Set it to  (page 22). → Set the flash to auto (No indicator),  (Forced flash) or  (Slow synchro) (page 29). → Set it to other settings (page 32). → Set the flash to  (Forced flash) (page 29). → Set it to other settings.
The close-ups (Macro) function does not work.	<ul style="list-style-type: none"> When shooting still images,  (Camera) in the menu is set to  (Magnifying glass mode),  (Twilight mode),  (Landscape mode) or  (Fireworks mode). 	<ul style="list-style-type: none"> → Set it to other settings (page 32).



Symptom	Cause	Solution
The eyes of the subject come out red.	—	→ Set [Red Eye Reduction] on the Setup screen to [On] (pages 29 and 106).
The date and time are recorded incorrectly.	• The date and time are not set correctly.	→ Set the correct date and time (pages 17 and 107).
The F value and shutter speed flash when you press and hold the shutter button halfway down.	• The exposure is incorrect.	→ Correct the exposure (page 50).

Viewing images

Symptom	Cause	Solution
Your camera cannot play back images.	<ul style="list-style-type: none"> • The mode switch is not set to . • The folder/file name has been changed on your computer. • Your camera cannot play back image files copied from the hard disk of your computer if the image has been modified. • The camera is set to USB mode. 	<ul style="list-style-type: none"> → Set it to  (page 35). → See page 85. <p>—</p> <ul style="list-style-type: none"> → Finish the USB connection (pages 80 and 86).
The image appears rough right after playback starts.	• The image may appear rough right after playback starts due to the image processing.	→ This is not a malfunction.
The image does not appear on the TV screen.	<ul style="list-style-type: none"> • The video output signal setting of your camera on the Setup screen is incorrect. • The connection is not correct. • The USB jack is connected. 	<ul style="list-style-type: none"> → Change the setting (pages 44 and 107). → Check the connection (page 37). → Follow the procedure of the note  on page 80 (Windows) or  on page 86 (Macintosh) and disconnect the USB cable.
The image cannot be played back on a computer.	—	→ See page 93.

Deleting/Editing Images

Symptom	Cause	Solution
Your camera cannot delete an image.	<ul style="list-style-type: none">The image is protected.You are using a "Memory Stick Duo" with a write-protect switch, and the write-protect switch is set to the LOCK position.	<ul style="list-style-type: none">→ Cancel the protection (page 66).→ Set it to the recording position (page 109).
You have deleted an image by mistake.	<ul style="list-style-type: none">Once you have deleted an image, you cannot restore it.	<ul style="list-style-type: none">→ Marking  (protect) will prevent you from deleting images by mistake (page 66).→ Accidental deletion can be prevented by setting the write-protect switch of a "Memory Stick Duo" that has a write-protect switch to the LOCK position (page 109).
The resizing function does not work.	<ul style="list-style-type: none">You cannot resize movies and Multi Burst images.	—
You cannot display a print (DPOF) mark.	<ul style="list-style-type: none">You cannot display print (DPOF) marks on movies.	—
You cannot cut images.	<ul style="list-style-type: none">The movie is not long enough to cut.Protected movie cannot be cut.Still images cannot be cut.	<ul style="list-style-type: none">—→ Cancel the protection (page 66).—

Computers

Symptom	Cause	Solution
You do not know if the OS of your computer is compatible.	—	→ Check "Recommended computer environment" (pages 75 and 86).
You cannot install the USB driver.	—	→ In Windows 2000, log on as Administrator (authorized Administrators) (page 75).

Symptom	Cause	Solution
Your computer does not recognize your camera.	<ul style="list-style-type: none"> • The camera is turned off. • The battery level is low. • You are not using the supplied USB cable. • The USB cable is not connected firmly. • The camera is not properly installed to the USB cradle. • [USB Connect] is set to [PTP] on the Setup screen. • The USB connectors on your computer are connected to other equipment besides the keyboard, the mouse and the USB cradle. • The camera is not connected directly to your computer. • The USB driver is not installed. • Your computer does not properly recognize the device because you connected the camera and your computer with the USB cable before you installed the “USB Driver” from the CD-ROM (supplied). 	<ul style="list-style-type: none"> → Turn on the camera (page 16). → Use the AC Adaptor (page 15). → Use the supplied USB cable (page 79). → Disconnect the USB cable from both the computer and the USB cradle, and connect it again firmly. Make sure that “USB Mode” is displayed on the LCD screen (page 79). → Properly install the camera (page 10). → Set it to [Normal] (pages 44 and 107). → Disconnect all equipment other than the keyboard, the mouse and the USB cradle from the USB connectors. → Connect the camera directly to your computer without passing through a USB hub or other device. → Install the USB driver (page 76). → Delete the incorrectly recognized device from your computer (page 82), then install the USB driver (page 76).
You cannot copy images.	<ul style="list-style-type: none"> • The camera is not correctly connected to your computer. • You are not using the correct copy procedure for your OS. — — 	<ul style="list-style-type: none"> → Connect the camera and your computer correctly using the USB cable (page 79). → Follow the designated copy procedure for your OS (pages 81, 82 and 86). → If you use the “Image Transfer” software, see page 80. → If you are using the “ImageMixer Ver. 1.5 for Sony” application software, click on HELP.
After making a USB connection, “Image Transfer” does not automatically start.	<ul style="list-style-type: none"> — — 	<ul style="list-style-type: none"> → Select [Launch Image Transfer automatically when your camera, etc., is connected.] at [Basic] setting (page 81). → Make a USB connection when the computer is turned on (page 79).
The image cannot be played back on a computer.	<ul style="list-style-type: none"> — — 	<ul style="list-style-type: none"> → If you are using the “ImageMixer Ver. 1.5 for Sony” application software, click on HELP. → Consult the computer or software manufacturer.

Symptom	Cause	Solution
The image and sound are interrupted by noise when you view a movie on a computer.	<ul style="list-style-type: none"> You are playing back the file directly from the "Memory Stick Duo." 	→ Copy the file to the hard disk of your computer and then play back the file from the hard disk (pages 80, 81, 82 and 86).
You cannot print an image.	— —	→ Check the printer settings. → Click on HELP for the "ImageMixer Ver. 1.5 for Sony" application software.
An error message appears when you set the CD-ROM (supplied) in your computer.	<ul style="list-style-type: none"> The computer display is not set correctly. 	→ Set the computer display as follows: Windows: 800 × 600 dots or more High Color (16-bit color, 65,000 colors) or more Macintosh: 800 × 600 dots or more 32,000-color mode or more

"Memory Stick Duo"



Symptom	Cause	Solution
You cannot insert a "Memory Stick Duo."	<ul style="list-style-type: none"> You are inserting it incorrectly. 	→ Insert it from the right side (page 19).
You cannot record on a "Memory Stick Duo."	<ul style="list-style-type: none"> You are using a "Memory Stick Duo" with a write-protect switch, and the write-protect switch on the "Memory Stick Duo" is set to the LOCK position. The "Memory Stick Duo" is full. The image size is set to [640(Fine)] when recording movies. 	→ Set it to the recording position (page 109). → Delete unnecessary images (pages 39 and 72). → Insert a "Memory Stick PRO Duo" (pages 70 and 109). → Set the image size to other than [640(Fine)].
You cannot format a "Memory Stick Duo."	<ul style="list-style-type: none"> You are using a "Memory Stick Duo" with a write-protect switch, and the write-protect switch on the "Memory Stick Duo" is set to the LOCK position. 	→ Set it to the recording position (page 109).
You have formatted a "Memory Stick Duo" by mistake.	<ul style="list-style-type: none"> All the data on the "Memory Stick Duo" are deleted by formatting. You cannot restore them. 	→ We recommend that you set the "Memory Stick Duo" write-protect switch to the LOCK position to prevent accidental erasure (page 109).



Others

Symptom	Cause	Solution
Your camera does not work.	<ul style="list-style-type: none"> • You are not using an “InfoLITHIUM” battery pack. • The battery level is low. (The  indicator appears.) • The AC Adaptor is not connected securely. • The camera is not properly installed to the USB cradle. 	<ul style="list-style-type: none"> → Use an “InfoLITHIUM” battery pack (page 111). → Charge the battery pack (page 11). → Connect it securely to the multi connector of your camera and to a wall outlet (wall socket) (page 15). → Properly install the camera (page 10).
The power is on, but the camera does not work.	<ul style="list-style-type: none"> • The built-in microcomputer is not working properly. 	<ul style="list-style-type: none"> → Disconnect, and then, after one minute, reconnect all power sources and turn on the camera. If this does not work, press the RESET button on the lower side of the control button using a fine-tipped object, then turn on the power again. (All the settings including date and time are cleared.)
You cannot identify an indicator on the LCD screen.	—	<ul style="list-style-type: none"> → Check the indicator (pages 114 to 117).
The lens gets fogged.	<ul style="list-style-type: none"> • Moisture condensation has occurred. 	<ul style="list-style-type: none"> → Turn off the camera and leave for about an hour at room temperature for the moisture to evaporate before use (page 108).
The camera becomes warm when you use it for a while.	—	<ul style="list-style-type: none"> → This is not a malfunction.

Warnings and messages

The following messages may appear on the LCD screen.

Message	Meaning/Corrective Action
No Memory Stick	<ul style="list-style-type: none">• Insert a “Memory Stick Duo” (page 19).
System error	<ul style="list-style-type: none">• Turn the power off and on again (page 16).
Memory Stick error	<ul style="list-style-type: none">• The inserted “Memory Stick Duo” cannot be used in your camera (page 109).• The “Memory Stick Duo” is damaged, or the terminal section of the “Memory Stick Duo” is dirty.• Insert the “Memory Stick Duo” correctly (page 19).
Memory Stick type error	<ul style="list-style-type: none">• The inserted “Memory Stick Duo” cannot be used in your camera (page 109).
Format error	<ul style="list-style-type: none">• Failed to format the “Memory Stick Duo.” Format the “Memory Stick Duo” again (page 41).• Re-insert the “Memory Stick Duo” several times (page 19).
Memory Stick locked	<ul style="list-style-type: none">• You are using a “Memory Stick Duo” with a write-protect switch, and the write-protect switch on the “Memory Stick Duo” is set to the LOCK position. Set it to the recording position (page 109).
No memory space	<ul style="list-style-type: none">• The capacity of the “Memory Stick Duo” is insufficient. You cannot record images. Delete unnecessary images or data (pages 39 and 72).
Read only memory	<ul style="list-style-type: none">• Your camera cannot record or delete images to this “Memory Stick Duo.”
No file in this folder	<ul style="list-style-type: none">• No images have been recorded in this folder.
Folder error	<ul style="list-style-type: none">• A folder with the same first three digits number already exists in the “Memory Stick Duo.” (For example: 123MSDCF and 123ABCDE) Select other folders, or create a new folder.
Cannot create more folders	<ul style="list-style-type: none">• The folder whose first three digits of the name is “999” exists in the “Memory Stick Duo.” You cannot create any folders.
Cannot record	<ul style="list-style-type: none">• The camera cannot record images in the selected folder. Select a different folder (page 45).
Lens cover closed	<ul style="list-style-type: none">• The lens cover is closed when the mode switch is set to  or .
File error	<ul style="list-style-type: none">• An error occurred while playing back the image.
For "InfoLITHIUM" battery only	<ul style="list-style-type: none">• The battery pack is not the “InfoLITHIUM” type.
Image size over	<ul style="list-style-type: none">• You are playing back an image of a size that cannot be played back on your camera.

Message	Meaning/Corrective Action
Cannot divide	<ul style="list-style-type: none"> • The movie is not long enough to be divided. • The file is not a movie.
Invalid operation	<ul style="list-style-type: none"> • You are playing back a file that was created on equipment other than this camera.
	<ul style="list-style-type: none"> • The battery level is low or zero. Charge the battery pack (page 11). Depending on the conditions of use or the type of battery pack, the indicator may flash even though there are still 5 to 10 minutes of remaining battery time left.
	<ul style="list-style-type: none"> • The amount of lights is not sufficient, so you are not holding the camera steady enough. Use the flash, secure the camera in place. But the vibration warning indicator does not disappear. • The camera is unsteady, so vibration easily occurs. Hold the camera steady with both hands and shoot the image. However, note that the vibration warning indicator does not disappear.
640(Fine) is not available	<ul style="list-style-type: none"> • Insert a “Memory Stick PRO Duo.”

Self-diagnosis display

– If a code starting with an alphabet letter appears

Your camera has a self-diagnosis display. This function displays the camera condition on the LCD screen with a combination of a letter and four numerical digits. If this occurs, check the following code chart and attempt the corresponding corrective actions. The last two digits (indicated by □□) will differ depending on the state of the camera.

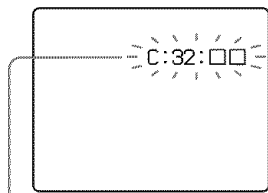

Self-diagnosis display

Code	Cause	Corrective action
C:32: □□	There is trouble with your camera's hardware.	Turn the power off and on again (page 16).
C:13: □□	The camera cannot read or write data on the "Memory Stick Duo."	Re-insert the "Memory Stick Duo" several times.
	An unformatted "Memory Stick Duo" is inserted.	Format the "Memory Stick Duo" (page 41).
	The inserted "Memory Stick Duo" cannot be used with your camera, or the data is damaged.	Insert a new "Memory Stick Duo" (page 19).
E:61: □□ E:91: □□	A camera malfunction that you cannot reverse has occurred.	Press the RESET button (page 88) located on the lower right side of the control button, then turn on the power again.

If you are unable to solve the problem even after trying the corrective actions a few times, contact your Sony dealer or local authorized Sony service facility.

Number of images that can be saved or shooting time

The number of images that can be saved and the shooting time differ, depending on the capacity of the “Memory Stick Duo,” the image size, and the image quality. Refer to the following charts when you choose a “Memory Stick Duo.”

- The number of images is listed in Fine (Standard) order.
- The values for the number of images that can be saved and the shooting time may vary, depending on the shooting conditions.
- For normal shooting times and numbers of images that can be saved, see page 21.
- When the number of remaining shooting images is greater than 9999, the “>9999” indicator appears on the LCD screen.

E-Mail

(Units: images)

	16MB	32MB	64MB	128MB	MSX-M256	MSX-M512
5M	6 (11)	12 (23)	25 (46)	50 (94)	91 (170)	186 (345)
3:2	6 (11)	12 (23)	25 (46)	50 (94)	91 (170)	186 (345)
3M	9 (17)	20 (35)	40 (71)	80 (143)	145 (255)	296 (518)
1M	23 (42)	47 (85)	96 (171)	192 (343)	340 (595)	691 (1210)
VGA	81 (162)	163 (327)	328 (657)	658 (1317)	1190 (2381)	2420 (4841)

Voice

(Units: images)

	16MB	32MB	64MB	128MB	MSX-M256	MSX-M512
5M	6 (11)	12 (22)	25 (45)	50 (91)	90 (166)	183 (337)
3:2	6 (11)	12 (22)	25 (45)	50 (91)	90 (166)	183 (337)
3M	9 (17)	19 (34)	39 (69)	79 (138)	142 (246)	290 (500)
1M	22 (38)	45 (78)	91 (157)	183 (316)	324 (549)	660 (1117)
VGA	69 (121)	140 (245)	281 (492)	564 (987)	1020 (1785)	2074 (3630)

When the recording time is five seconds

Multi Burst

(Units: images)

	16MB	32MB	64MB	128MB	MSX-M256	MSX-M512
1M	24 (46)	50 (93)	101 (187)	202 (376)	357 (649)	726 (1320)

Movie

	16MB	32MB	64MB	128MB	MSX-M256	MSX-M512
640(Fine)	—	—	—	—	0:02:57	0:06:02
640(Standard)	0:00:42	0:01:27	0:02:56	0:05:54	0:10:42	0:21:47
160	0:11:12	0:22:42	0:45:39	1:31:33	2:51:21	5:47:05

Recording time notation

The time is indicated as hours, minutes, seconds in order from the left. Example:

[1:10:28] → 1 hour, 10 minutes, 28

















seconds









Menu items

Menu items that can be modified differ depending on the position of the mode switch.

Factory settings are indicated with ■.





When the mode switch is set to



Item	Setting	Description
 (Camera)	 /  /  /  /  /  /  / Program / ■Auto	Selects the camera mode (page 23).
 (EV) ¹⁾	+2.0EV / +1.7EV / +1.3EV / +1.0EV / +0.7EV / +0.3EV / ■0EV / -0.3EV / -0.7EV / -1.0EV / -1.3EV / -1.7EV / -2.0EV	Adjusts the exposure (page 50).
 (Focus) ^{1) 5)}	∞ / 7.0m / 3.0m / 1.0m / 0.5m / Spot AF / Center AF / ■Multi AF	Chooses the auto focus method (page 47), or sets the focus preset distance (page 49).
 (Metering Mode) ¹⁾	Spot / ■Multi	Adjusts the exposure to the subject you are shooting (page 52). Sets the metering region.
WB (White Bal) ^{1) 5)}	 /  /  /  /  / ■Auto	Sets the white balance (page 54).
ISO ¹⁾	400 / 200 / 100 / ■Auto	Selects the ISO sensitivity. Select a large number when shooting in dark locations or shooting a subject moving at high speed, or select a small number to obtain high image quality. • Note that the image tends to become noisier as the ISO sensitivity number increases.
 (P.Quality) ¹⁾	■Fine / Standard	Records images with fine/standard quality (page 44).

Item	Setting	Description
Mode (REC Mode)⁵⁾	Voice E-Mail Multi Burst Exp Brktg Framing Burst Speed Burst ■Normal	– Records an audio file (with a still image) in addition to the JPEG file (page 58). – Records a small-size (320×240) JPEG file in addition to the selected image size (page 57). – Records a continuous burst of 16 frames within a single still image in a single press of the shutter button (image size 1M) (page 56). – Records three images with the exposure value of each image slightly shifted (page 52). – Records a Multi Burst series of images while displaying the images on the LCD screen (page 55). – Records a Multi Burst series of images with a short shooting interval (page 55). – Records an image using the normal recording mode.
BRK (Bracket Step)³⁾	±1.0EV / ■±0.7EV / ±0.3EV	Sets the exposure compensation value when recording three images with each exposure adjustment value (page 52). (This setting cannot be made when [Mode] (REC Mode) in the menu is set to other than [Exp Brktg].)
 (Interval)³⁾	1/7.5 / 1/15 / ■1/30	Selects the Multi Burst shutter interval (page 56). (This setting cannot be made when [Mode] (REC Mode) in the menu is set to other than [Multi Burst].)
 (Flash Level)⁴⁾	High / ■Normal / Low	Selects the amount of flash light (page 55).
PFX (P.Effect)¹⁾	Solarize / Sepia / Neg. Art / ■Off	Sets the image special effects (page 58).
 (Saturation)²⁾	+ / ■Normal / -	Adjusts the saturation of the image. The  indicator appears (except when the setting is Normal).
 (Contrast)²⁾	+ / ■Normal / -	Adjusts the contrast of the image. The  indicator appears (except when the setting is Normal).
 (Sharpness)²⁾	+ / ■Normal / -	Adjusts the sharpness of the image. The  indicator appears (except when the setting is Normal).

¹⁾ This does not appear when  (Camera) in the menu is set to [Auto].













²⁾ This does not appear when  (Camera) in the menu is set to other than [Program].

³⁾ This does not appear when  (Camera) in the menu is set to [Auto],  (Magnifying glass mode),  (Twilight mode),  (Twilight portrait mode) or  (Fireworks mode).









⁴⁾ This does not appear when  (Camera) in the menu is set to [Auto],  (Twilight mode) or  (Fireworks mode).

⁵⁾ The available settings are limited according to the  (Camera) setting in the menu.



When the mode switch is set to

Item	Setting	Description
 (EV)	+2.0EV / +1.7EV / +1.3EV / +1.0EV / +0.7EV / +0.3EV /  0EV / -0.3EV / -0.7EV / -1.0EV / -1.3EV / -1.7EV / -2.0EV	Adjusts the exposure (page 50).
 (Focus)	∞ / 7.0m / 3.0m / 1.0m / 0.5m / Spot AF / Center AF /  Multi AF	Chooses the auto focus method (page 47), or sets the focus preset distance (page 49).
 (Metering Mode)	Spot /  Multi	Adjusts the exposure to the subject you are shooting (page 52). Sets the metering region.
WB (White Bal)	 /  /  /  /  Auto	Sets the white balance (page 54).
PFX (P.Effect)	Solarize / Sepia / Neg. Art /  Off	Sets the image special effects (page 58).

When the mode switch is set to







Item	Setting	Description
 (Folder)	OK / Cancel	Selects the folder containing the image you want to play back (page 60).
 (Protect)	—	Protects and unprotects images against accidental erasure (page 66).
DPOF (DPOF)	—	Marks and unmarks the print (DPOF) mark on still images you want to print (page 68).
 (Slide)	Interval Image Repeat Start Cancel	<ul style="list-style-type: none"> – Sets the slide show interval (page 62). (Only in single-image mode) <ul style="list-style-type: none"> ■ 3 sec / 5 sec / 10 sec / 30 sec / 1 min – Sets the range of the playback images. <ul style="list-style-type: none"> ■ Folder / All – Plays back images repeatedly. <ul style="list-style-type: none"> ■ On / Off – Starts the slide show. – Cancels the slide show.
 (Resize)	5M / 3M / 1M / VGA / Cancel	Changes the recorded still image size (page 67). (Only in single-image mode)
 (Rotate)	 (counter clockwise) /  (clockwise) / OK / Cancel	Rotates the still image (page 63). (Only in single-image mode)
 (Divide)	OK / Cancel	Divides movie (page 74). (Only in single-image mode)

Setup items

The Setup screen appears when you advance to  in the menu and press  again.

Factory settings are indicated with .

(Camera)

Item	Setting	Description
AF Mode	 Single / Monitor / Cont	Selects the focus operation mode (page 48).
Digital Zoom	 Smart / Precision / Off	Selects the digital zoom mode (page 26).
Date/Time	Day & Time / Date /  Off	Selects whether to superimpose the date or time onto the image (page 30). The date and time are not inserted in movie or Multi Burst mode. Also, the date and time appear only during playback, and do not appear during recording.
Red Eye Reduction	On /  Off	Reduces the red-eye phenomenon when using a flash (page 29).
AF Illuminator	 Auto / Off	Selects whether to emit an AF assist light in the dark. Helps when it is hard to focus on the subject under dark lighting (page 30).
Auto Review	On /  Off	Selects whether to automatically display the recorded image on the LCD screen immediately after shooting a still image. When set to [On], the recorded image is displayed for approximately two seconds. You cannot shoot the next image during this period.

(Memory Stick Tool)

Item	Setting	Description
Format	OK / Cancel	Formats the “Memory Stick Duo.” Note that formatting erases all data on a “Memory Stick Duo,” including even protected images (page 41).
Create REC. Folder	OK / Cancel	Creates a folder for recording images (page 45).
Change REC. Folder	OK / Cancel	Changes a folder for recording images (page 46).

 (Setup 1)

Item	Setting	Description
LCD Brightness	Bright / <input checked="" type="checkbox"/> Normal / Dark	Selects the LCD brightness. This has no effect on the recorded images.
LCD Backlight	Bright / <input checked="" type="checkbox"/> Normal	Selects the brightness of the LCD backlight. Selecting [Bright] makes the screen bright and easy to see when using the camera outdoors or in other bright locations, but also uses up the battery charge faster. Displayed only when using your camera with the battery pack.
Beep	Shutter <input checked="" type="checkbox"/> On Off	<ul style="list-style-type: none">– Turns on the shutter sound. (The shutter sound is heard when you press the shutter button.)– Turns on the beep/shutter sound when you press the control button/shutter button.– Turns off the beep/shutter sound.
Language	—	Displays the menu items, warnings and messages in selected language.

 (Setup 2)

Item	Setting	Description
File Number	<input checked="" type="checkbox"/> Series Reset	<ul style="list-style-type: none">– Assigns numbers to files in sequence even if the “Memory Stick Duo” is changed or the recording folder is changed.– Resets the file numbering and starts from 0001 each time the folder is changed. (When the recording folder contains a file, a number one higher than the largest number is assigned.)
USB Connect	PTP / <input checked="" type="checkbox"/> Normal	Switches the USB mode (page 79).
Video Out	NTSC PAL	<ul style="list-style-type: none">– Sets the video output signal to NTSC mode (e.g., USA, Japan).– Sets the video output signal to PAL mode (e.g., Europe).
Clock Set	OK / Cancel	Sets the date and time (pages 17 and 44).

Precautions

Do not leave the camera in the following places

- In extremely hot place, such as in a car parked in the sun. The camera body may become deformed or this may cause a malfunction.
- Under direct sunlight or near a heater. The camera body may become deformed or this may cause a malfunction.
- On rocking vibration
- Near strong magnetic place
- In sandy or dusty places, be careful not to let sand or dust get into the camera. This may cause the camera to malfunction, and in some cases this malfunction cannot be repaired.

On carrying

Do not sit down in a chair or other place with the camera in the back pocket of your trousers or skirt, as this may cause malfunction or damage the camera.

On cleaning

Cleaning the LCD screen

Wipe the screen surface with an LCD cleaning kit (not supplied) to remove fingerprints, dust, etc.

Cleaning the DC plug

Clean the DC plug of the AC Adaptor. Do not use the dirty plug. Use of the dirty plug may not properly charge the battery pack.

Cleaning the lens

Wipe the lens with a soft cloth to remove fingerprints, dust, etc.

Cleaning the camera surface

Clean the camera surface with a soft cloth slightly moistened with water, then wipe the surface with a dry cloth. Do not use the following as this may damage the finish or the casing.

- Thinner
- Benzine
- Alcohol
- Disposable cloth
- Volatile insecticide
- Contact with rubber or vinyl for a long time

On operating temperature

The camera is designed for use between the temperatures of 0°C and 40°C (32°F and 104°F). Shooting in extremely cold or hot places that exceed this range is not recommended.

On moisture condensation

If the camera is brought directly from a cold to a warm location, or is placed in a very damp room, moisture may condense inside or outside the camera. This moisture condensation may cause a malfunction of the camera.

Moisture condensation occurs easily when:

- The camera is brought from a cold location such as a ski slope into a warmly heated room.
- The camera is taken from an air-conditioned room or car interior to the hot outdoors, etc.

How to prevent moisture condensation

When bringing the camera from a cold place to a warm place, seal the camera in a plastic bag and allow it to adapt to conditions at the new location over a period of time (about an hour).

If moisture condensation occurs

Turn off the camera and wait about an hour for the moisture to evaporate. Note that if you attempt to shoot with moisture remaining inside the lens, you will be unable to record clear images.

On internal rechargeable button battery

This camera has an internal rechargeable button battery for maintaining the date and time and other settings regardless of whether the power is on or off.

This rechargeable button battery is continually charged as long as you are using the camera. However, if you use the camera for only short periods it discharges gradually, and if you do not use the camera at all for about one month it becomes completely discharged. In this case, be sure to charge this rechargeable button battery before using the camera.

However, even if this rechargeable button battery is not charged, you can still use the camera as long as you do not record the date and time.

Charging method

Connect the camera to a wall outlet (wall socket) using the AC Adaptor, or install a charged battery pack, and leave the camera for 24 hours or more with the power off.

- The internal rechargeable button battery is located inside the cover in the left side of battery insertion slot of the camera. Never remove the rechargeable button battery.

Rechargeable button battery

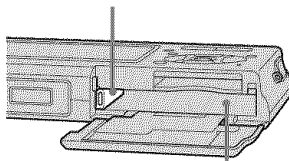

Battery insertion slot

On "Memory Stick"

"Memory Stick" is a compact, portable IC recording medium with a data capacity that exceeds the capacity of a floppy disk.

The types of "Memory Stick" that can be used with this camera are listed in the table below. However, proper operation cannot be guaranteed for all "Memory Stick" functions.

"Memory Stick" type	Recording/Playback ³⁾
Memory Stick	—
Memory Stick Duo	○
Memory Stick Duo (MagicGate/high-speed data transfer) ¹⁾	○ ²⁾
MagicGate Memory Stick	—
MagicGate Memory Stick Duo ¹⁾	○
Memory Stick PRO	—
Memory Stick PRO Duo ¹⁾	○ ²⁾

¹⁾ "MagicGate Memory Stick Duo" and "Memory Stick PRO Duo" are equipped with MagicGate functions. MagicGate is copyright protection technology that uses encryption technology. Data recording/playback that requires MagicGate functions cannot be performed with this camera.

²⁾ Supports high-speed data transfer using a parallel interface.

3) 640(Fine) size movies can be recorded and played back only using “Memory Stick PRO Duo.”

- “Memory Stick Duo” formatted with a computer is not guaranteed to operate with this camera.
- Data read/write speeds differ depending on the combination of the “Memory Stick Duo” and the equipment used.

Notes on using “Memory Stick Duo”

- You cannot record, edit or delete images if you slide the write-protect switch⁴⁾ to LOCK with a fine-tipped object.

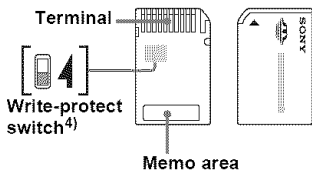

The position or the shape of the write-protect switch⁴⁾ may differ depending on the “Memory Stick Duo” you use.

⁴⁾ The “Memory Stick Duo” supplied with this camera does not have a write-protect switch. When using the supplied “Memory Stick Duo,” be careful not to edit or delete data by mistake.

- Do not remove the “Memory Stick Duo” while reading or writing data.
- Data may be corrupted in the following cases:
 - When the “Memory Stick Duo” is removed or the camera is turned off during read or write operation
 - When the “Memory Stick Duo” is used in locations subject to static electricity or electrical noise
- We recommend backing up important data.
- Do not press down hard when you write down on the memo area.
- Do not attach a label on the “Memory Stick Duo” itself nor on a Memory Stick Duo Adaptor.
- When you carry or store the “Memory Stick Duo,” put it in the case supplied with it.
- Do not touch the terminal of the “Memory Stick Duo” with your hand or a metal object.
- Do not strike, bend or drop the “Memory Stick Duo.”
- Do not disassemble or modify the “Memory Stick Duo.”
- Do not expose the “Memory Stick Duo” to water.
- Do not leave the “Memory Stick Duo” within the reach of small children. They might accidentally swallow it.
- Do not use or keep the “Memory Stick Duo” under the following conditions:
 - High temperature locations such as the hot interior of a car parked in direct sunlight
 - Locations exposed to direct sunlight
 - Humid locations or locations with corrosive substances

Notes on using a Memory Stick Duo Adaptor (supplied)

- When using a “Memory Stick Duo” with a “Memory Stick” compliant device, be sure to insert the “Memory Stick Duo” into a Memory Stick Duo Adaptor.
If you insert a “Memory Stick Duo” into a “Memory Stick” compliant device without a Memory Stick Duo Adaptor, you might not be able to remove it from the device.
- When inserting a “Memory Stick Duo” into a Memory Stick Duo Adaptor, make sure the “Memory Stick Duo” is inserted facing in the correct direction, then insert it all the way in. Incorrect insertion may result in a malfunction.
- When using a “Memory Stick Duo” inserted into a Memory Stick Duo Adaptor with a “Memory Stick” compliant device, make sure that the “Memory Stick Duo” is inserted facing the correct direction. Note that improper use may damage the equipment.
- Do not insert a Memory Stick Duo Adaptor into a “Memory Stick” compliant device without a “Memory Stick Duo” attached. Doing so may result in malfunction of the unit.

Note on using “Memory Stick PRO Duo” (not supplied)

“Memory Stick PRO Duo” with a capacity up to 512MB have been confirmed to operate properly with this camera.

On "InfoLITHIUM" battery pack

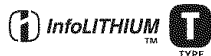

What is the "InfoLITHIUM" battery pack?

The "InfoLITHIUM" battery pack is a lithium-ion battery pack that has functions for communicating information related to operating conditions of your camera. The "InfoLITHIUM" battery pack calculates the power consumption according to the operating conditions of your camera, and displays the remaining battery time in minutes.

Charging the battery pack

We recommend charging the battery pack in an ambient temperature of between 10°C to 30°C (50°F to 86°F). You may not be able to efficiently charge the battery pack outside of this temperature range.

Effective use of the battery pack

- Battery performance decreases in low-temperature surroundings. So, the time that the battery pack can be used is shorter in cold places. We recommend the following to ensure longer battery pack use:
 - Put the battery pack in a pocket close to your body to warm it up, and insert it in your camera immediately before you start shooting.
- Frequently operating the zoom or flash wears out the battery charge faster.
- We recommend having spare battery packs handy for two or three times the expected shooting time, and making trial shots before taking the actual shots.
- Do not expose the battery pack to water. The battery pack is not water-resistant.

Remaining battery time indicator

The power may go off although the battery remaining indicator shows there is enough power to operate. Use the battery pack up and charge the battery pack fully again so that the indication on the battery remaining indicator is correct. Note, however, that the correct battery indication sometimes will not be restored if the camera is used in high temperatures for a long time or left in a fully charged state, or the battery pack is frequently used.

How to store the battery pack

- If the battery pack is not to be used for a long time, do the following procedure once per year to maintain proper function.
 - 1 Fully charge the battery.
 - 2 Discharge on your camera.
 - 3 Remove the battery from your camera and store it in a dry, cool place.
- To use the battery pack up on your camera, leave the POWER button to on in slide show playback mode (page 62) until the power goes off.
- Always carry and store the battery pack in the battery case to prevent the battery terminals from becoming dirty or short circuited.

Battery life

- The battery life is limited. Battery capacity decreases little by little as you use it more and more, and as time passes. When the battery operating time is shortened considerably, a probable cause is that the battery pack has reached the end of its life. Buy a new battery pack.
- The battery life varies according to how it is stored and the operating conditions and environment for each battery pack.

Specifications

■ Camera

[System]

Image device

7.66 mm (1/2.4 type) color CCD
Primary color filter

Total pixels number of camera

Approx. 5 255 000 pixels

Effective pixels number of camera

Approx. 5 090 000 pixels

Lens

Carl Zeiss Vario-Tessar
3× zoom lens
f = 6.7 – 20.1 mm (38 – 114 mm when
converted to a 35 mm still camera)
F3.5 – 4.4

Exposure control

Automatic exposure, Scene selection
(8 modes)

White balance

Automatic, Daylight, Cloudy,
Fluorescent, Incandescent, Flash

File format (DCF compliant)

Still images: Exif Ver. 2.2 JPEG
compliant, DPOF compatible
Audio with still image: MPEG1
compliant (Monaural)
Movies: MPEG1 compliant
(Monaural)

Recording media

“Memory Stick Duo”

Flash

Recommended distance (ISO set to
Auto):
0.3 m to 1.5 m (11 7/8 inches to
59 1/8 inches) (W)
0.5 m to 1.5 m (19 3/4 inches to
59 1/8 inches) (T)

[Input and Output connectors]

Multi connector

[LCD screen]

LCD panel

6.2 cm (2.5 type) TFT drive

Total number of dots

211 200 (960×220) dots

[General]

Used battery pack

NP-FT1

Power requirements

3.6 V

Power consumption (during shooting)

1.6 W

Operating temperature

0°C to +40°C (+32°F to +104°F)

Storage temperature

–20°C to +60°C (–4°F to +140°F)

Dimensions

91×60×21 mm
(3 5/8×2 3/8×2 7/32 inches)
(W/H/D, excluding maximum
protrusions)

Mass

Approx. 180 g (6.3 oz) (including
battery pack NP-FT1, “Memory Stick
Duo” and wrist strap)

Built-in microphone

Electret condenser microphone

Built-in speaker

Piezo-electric speaker

Exif Print

Compatible

PRINT Image Matching II

Compatible

■ UC-TA USB cradle

[Input and Output connectors]

A/V OUT (MONO) jack (Monaural)

Minijack

Video: 1 V_{p-p}, 75 Ω unbalanced,
sync negative

Audio: 327 mV (at a 47 kΩ load)
Output impedance 1 kΩ

USB jack B

USB connection

High-Speed USB
(USB 2.0 High-Speed compatible)

DC IN jack

Camera connector

■ AC-LM5 AC Adaptor

Power requirements

100 to 240 V AC, 50/60 Hz

Current consumption

0.2 A

Power consumption

10 W

Rated output voltage

4.2 V DC, 1.5 A

Operating temperature

0°C to +40°C (+32°F to +104°F)

Storage temperature

–20°C to +60°C (–4°F to +140°F)

Dimensions

Approx. 47×30×80 mm
(1 7/8×1 3/16×3 1/4 inches)
(W/H/D, excluding projecting parts)

Mass

Approx. 170 g (6.0 oz) excluding
power cord (mains lead)

■ NP-FT1 battery pack

Used battery

Lithium-ion battery

Maximum voltage

DC 4.2 V

Nominal voltage

DC 3.6 V

Capacity 2.4 Wh (680 mAh)

■ Accessories

- AC-LM5 AC Adaptor (1)
- Power cord (mains lead) (1)
- UC-TA USB cradle (1)
- USB cable (1)
- NP-FT1 battery pack (1)
- A/V connecting cable (1)
- Wrist strap (1)
- "Memory Stick Duo" (32 MB) (1)
- Memory Stick Duo Adaptor (1)
- CD-ROM (USB driver SPVD-013) (1)
- Operating instructions (1)

Design and specifications are subject to change without notice.

The LCD screen

When shooting still images

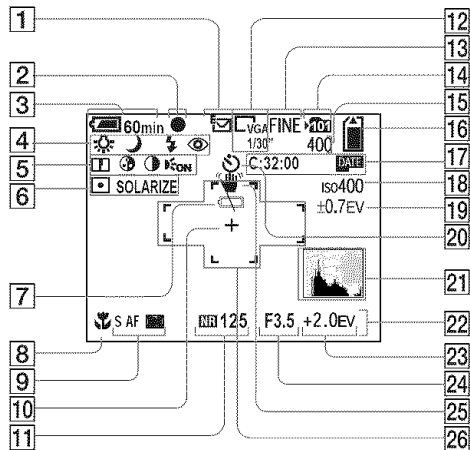

- 1 Recording mode indicator (52, 55-58)
- 2 AE/AF lock indicator (22, 49)
- 3 Battery remaining indicator (13)
- 4 White balance indicator (54)/Camera mode indicator (23)/Flash mode indicator (29)/Red-eye reduction indicator (29)

- 5 Sharpness indicator (103)/Saturation indicator (103)/Contrast indicator (103)/AF illuminator (30, 106)
- 6 Metering mode indicator (52)/Picture effect indicator (58)
- 7 Low battery warning indicator (98)
- 8 Macro indicator (27)
- 9 AF mode (48)/AF range finder frame indicator (47)/Focus preset value (49)

- 10 Spot metering cross hair (52)
- 11 NR slow shutter indicator (34)/Shutter speed indicator
- 12 Multi Burst interval indicator (56)/Image size indicator (20)
- 13 Image quality indicator (44)
- 14 Recording folder indicator (45)
- 15 Remaining number of recordable images indicator (21)
- 16 Remaining "Memory Stick" capacity indicator
- 17 Self-diagnosis display (99)/Date/Time indicator (17)
- 18 ISO number indicator (102)
- 19 Bracket step value indicator (52)
- 20 Self-timer indicator (28)
- 21 Histogram indicator (51)
- 22 Menu/Guide menu (43)
- 23 EV level indicator (50)
- 24 Aperture value indicator
- 25 Vibration warning indicator (98)
- 26 AF range finder frame (47)

Page numbers in parentheses indicate the location of additional important information.

When shooting movies

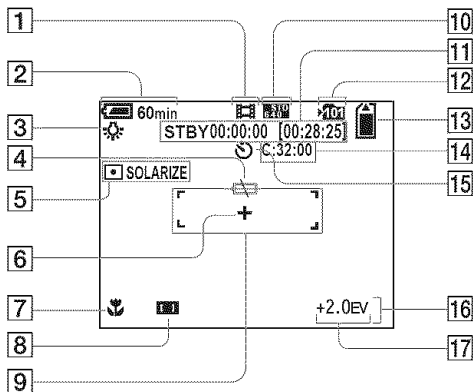

- | | |
|--|--|
| 1 Recording mode indicator (70) | 12 Recording folder indicator (45) |
| 2 Battery remaining indicator (13) | 13 Remaining "Memory Stick" capacity indicator |
| 3 White balance indicator (54) | 14 Self-diagnosis display (99) |
| 4 Low battery warning indicator (98) | 15 Self-timer indicator (28) |
| 5 Metering mode indicator (52)/ Picture effect indicator (58) | 16 Menu/Guide menu (43) |
| 6 Spot metering cross hair (52) | 17 EV level indicator (50) |
| 7 Macro indicator (27) | |
| 8 AF range finder frame indicator (47)/Focus preset value (49) | |
| 9 AF range finder frame (47) | |
| 10 Image size indicator (70) | |
| 11 Recording time [maximum recordable time] indicator (101) | |

Page numbers in parentheses indicate the location of additional important information.

When playing back still images

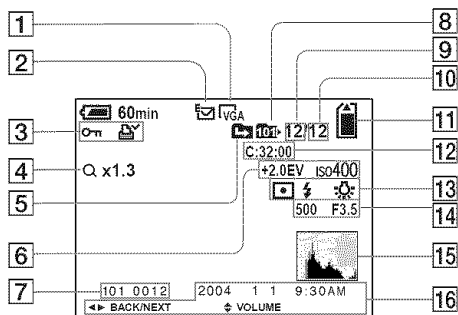

- 1 Image size indicator (20)
- 2 Recording mode indicator (52, 55-58)
- 3 Volume indicator (58)/Protect indicator (66)/Print (DPOF) mark indicator (68)
- 4 Zoom scaling indicator (61)/Jog playback indicator (65)
- 5 Change folder indicator (46)
- 6 EV level indicator (50)/ISO number indicator (102)
- 7 Folder-file number (83)
- 8 Playback folder indicator (60)
- 9 Image number
- 10 Number of images recorded in selected folder
- 11 Remaining "Memory Stick" capacity indicator
- 12 Self-diagnosis display (99)
- 13 Metering mode indicator (52)/Flash indicator/White balance indicator (54)
- 14 Shutter speed indicator/Aperture value indicator
- 15 Histogram indicator (51)
- 16 Recording date of the playback image (30)/Menu/Guide menu (43)

Page numbers in parentheses indicate the location of additional important information.

When playing back moving images

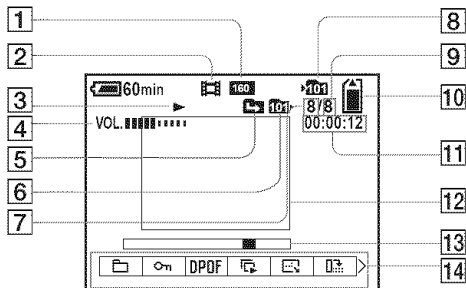

- 1 Image size indicator (70)
- 2 Recording mode indicator (70)
- 3 Playback indicator (71)
- 4 Volume indicator (71)
- 5 Change folder indicator (60)
- 6 Playback folder indicator (60)
- 7 Image number
- 8 Recording folder indicator (45)
- 9 Number of images recorded in selected folder
- 10 Remaining "Memory Stick" capacity indicator
- 11 Counter (71)
- 12 Playback image (71)
- 13 Playback bar (71)
- 14 Menu/Guide menu (43)

- Pressing MENU switches the menu on/off.

Page numbers in parentheses indicate the location of additional important information.

Index

A

AC Adaptor	11, 15
Access lamp	19
AE/AF lock	22, 24, 49
AF illuminator	30, 106
AF lock	49
AF Mode	48
AF range finder frame	47
Auto adjustment mode	22
Auto Focus	24, 47
Auto power-off function	16
Auto Review	106
A/V connecting cable	37

B

Battery life	14, 111
Battery remaining indicator	13, 111
Beep/shutter sound	107
Burst	55

C

CD-ROM	75
Center AF	47
Charging battery pack	11, 111
Charging time	13
Cleaning	108
Clock Set	17, 44, 107
Close-ups (Macro) shooting	27
Continuous AF	48
Contrast	103

Control button	16
Copying images to your computer	80, 81, 82, 86
Cutting movies	74

D

DC plug	11, 15
Deleting movies	72
Deleting still images	39
Digital zoom	26
Divide	74
DPOF	68

E

E-mail	57
Enlarging an image	61
EV adjustment	50
Exposure Bracket	52

F

File names	83
File storage destinations	83
Flash	29
Flash Level	55
Focus preset	49
Folder	45, 60
Format	41
Framing priority burst	55

H

Histogram	51
-----------------	----

I

Image quality	44
Image size	20, 21, 100
Image Transfer	77
ImageMixer	78
Index screen	36
“InfoLITHIUM” battery pack	111
Inserting “Memory Stick Duo”	19
Install	76, 77, 78
ISO	102

J

JPG	84
-----------	----

L

LCD backlight on/off	25
LCD screen brightness	107

M

Macro	27
Memory Stick Duo	19, 109
Menu settings	43, 102
Metering mode	52
Mode switch	9, 17, 23
Moisture condensation	108
Monitoring AF	48
MPG	84
Multi Burst	56, 64
Multi-pattern metering	52
Multipoint AF	47

N

NR slow shutter	34
NTSC system	38, 107
Number of images that can be shot or viewed	14, 21, 100

P

PAL system	38, 107
Picture effect	58
Playback zoom	61
Power on/off	16
Precautions	108
Precision digital zoom	26
Print (DPOF) mark	68
Program auto shooting mode	23
Protect	66
PTP	75, 86, 107

Q

Quick Review	24
--------------------	----

R

Red Eye Reduction	29
Remaining shooting/viewing time	14, 100
RESET button	88
Resize	67
Rotate	63

S

Saturation	103
Scene Selection	32
Screen display	25, 114
Self-diagnosis display	99
Self-timer	28
Setting date and time	17, 107
Setup	44, 106
Sharpness	103
Shooting movies	70
Shooting still images	22
Single AF	48
Single screen	35
Slide show	62
Smart Zoom	26
Speed priority burst	55
Spot AF	47
Spot metering	52
Superimposing date and time	30, 106

T

Trimming	62
TV color system	38

U

USB connection	79, 107
USB cradle	10
USB driver	76, 86
USB jack	10, 79
USB mode	75, 86
Using your camera abroad	15

V

VGA	21, 100
Viewing images on TV	37
Viewing images on your computer	87
Viewing movies on the LCD screen	71
Viewing still images on the LCD screen	35
Voice	58

W

Warnings and messages	97
White Balance	54

Z

Zoom	25
------------	----

3085733120



Printed on 100% recycled paper
using VOC (Volatile Organic
Compound)-free vegetable oil
based ink.

<http://www.sony.net/>
Sony Corporation Printed in Japan

Additional information on this product and answers to frequently
asked questions can be found at our Customer Support Website.