

# INSTALLATION INSTRUCTIONS

These instructions must be affixed on or adjacent to the boiler

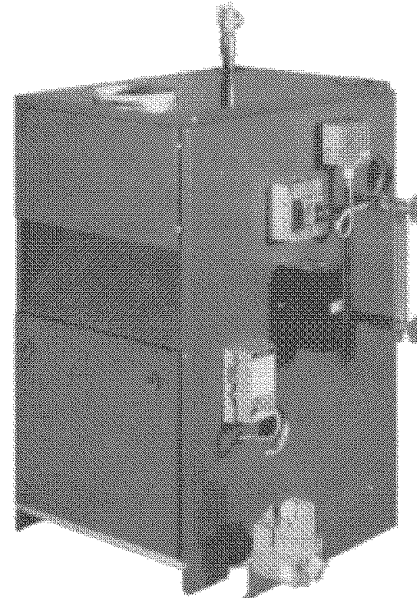
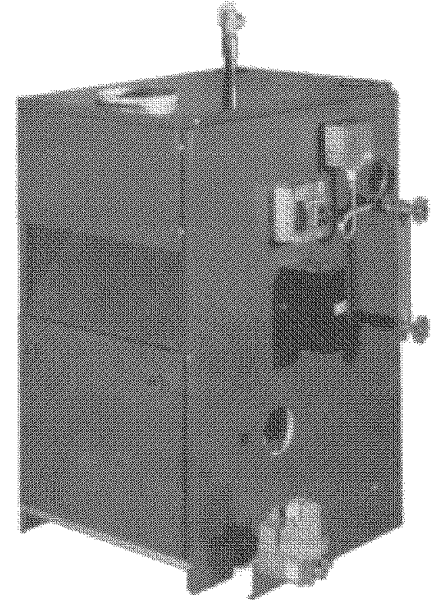
## Dunkirk

# PLYMOUTH STEAM SERIES 2

## Gas-Fired Steam Boilers

These Gas-Fired Water Boilers are low pressure, sectional cast iron boilers Designed Certified by C.S.A. (Canadian Standards Association) for use with Natural and Propane Gases. They are constructed and hydrostatically tested for a maximum working pressure of 50 psi (pounds per square inch) in accordance with A.S.M.E. (American Society of Mechanical Engineers) Boiler and Pressure Vessel Code Section IV Standards for cast iron heating boilers.

**MODEL PVSB**  
Continuous Pilot



**MODEL PSB**  
Electronic  
Intermittent  
Ignition

**Warning:** Improper installation, adjustment, alteration, service or maintenance can cause injury or property damage. Refer to this manual. For assistance or additional information consult a qualified installer, service agency or the gas supplier

## DUNKIRK BOILERS

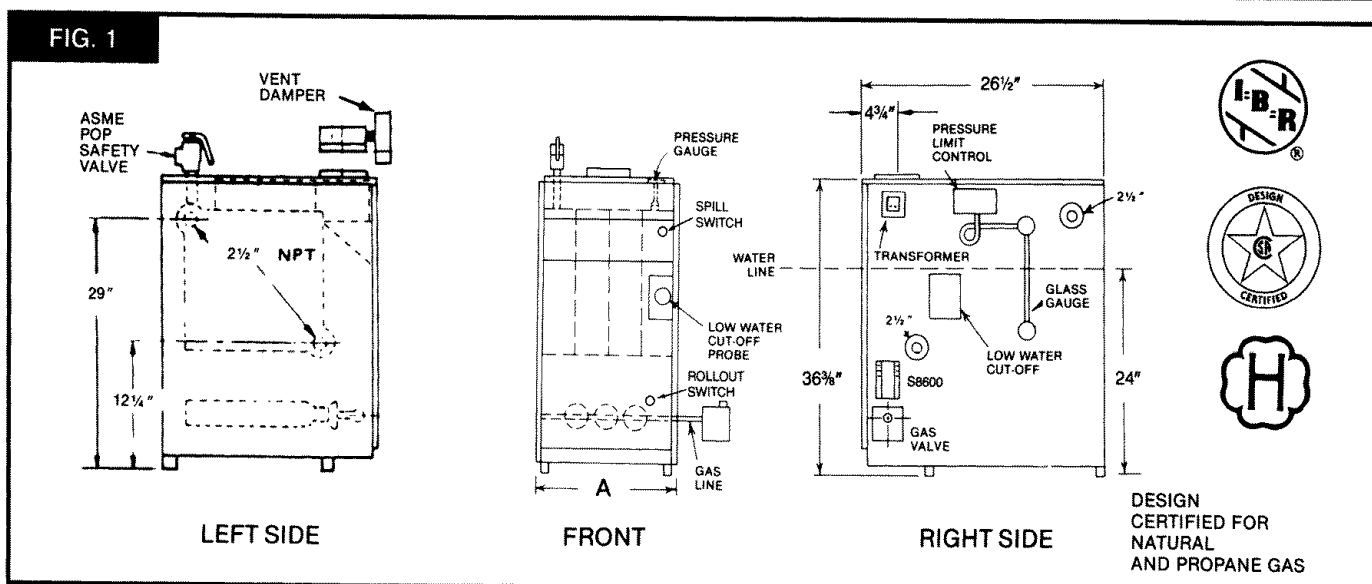
DUNKIRK, NEW YORK 14084 • AREA CODE 716 366-5500

*MEMBER: The Hydronics Institute*

# Contents

Boiler Ratings and Capacities .....	2	Controls and Accessories - What They Do .....	17
Before You Start.....	3	For Your Safety - Read Before Operating .....	18
Locating the Boiler .....	3	Operating Your Boiler .....	20
Fresh Air for Combustion .....	4	Checking and Adjusting .....	21
Installation - System Piping .....	5	Cleaning Your Boiler .....	22
Chimney and Vent Pipe Connection .....	8	Maintaining Your Boiler .....	23
Vent Damper Operation.....	9	Service Hints .....	24
Gas Supply Piping .....	10	Repair Parts.....	25
Electrical Wiring .....	11		

## Boiler Ratings and Capacities



### GAS-FIRED STEAM BOILERS

BOILER MODEL NUMBER		NO. OF SECTIONS	†NATURAL GAS				†PROPANE GAS				DIMENSIONS (Inches)	
INTERMITTENT IGNITION WITH VENT DAMPER	STANDING PILOT WITH VENT DAMPER		AGA INPUT *MBH	HEATING CAPACITY *MBH	NET I=B=R RATING *MBH	NET I=B=R RATING SQ. FT. RADIATION	AGA INPUT *MBH	HEATING CAPACITY *MBH	NET I=B=R RATING *MBH	NET I=B=R RATING SQ. FT. RADIATION	FLUE DIAMETER	"A" WIDTH
PSB-3D	PVSB-3D	3	75	62	47	196	70	58	44	183	5	11 1/4
PSB-4D	PVSB-4D	4	112	91	68	283	105	85	64	267	6	14 1/2
PSB-5D	PVSB-5D	5	150	122	92	383	140	114	86	358	6	17 3/4
PSB-6D	PVSB-6D	6	187	153	115	479	175	143	107	446	7	21
PSB-7D	PVSB-7D	7	225	183	137	571	210	171	128	533	7	24 1/4
PSB-8D	PVSB-8D	8	262	214	161	671	245	200	150	625	7	27 1/2
PSB-9D	PVSB-9D	9	299	245	184	767	280	229	172	717	7	30 3/4

\* MBH = 1,000 Btu/h. Btu/h = British Thermal Unit Per Hour.  
 \*\*Add 5 1/2" to height for Vent Damper.

† For altitudes above 2,000 ft. ratings should be reduced at the rate of 4% for each 1,000 ft. above sea level.  
 Heating Capacity is based on D.O.E. (Department of Energy) test procedure.

The City of New York MEA Number 77-91-E.

The Ratings marked "Net I=B=R Ratings" indicate the amount of equivalent direct cast iron radiation each boiler will take care of under normal conditions and thermostatic control. The Net I=B=R Steam Ratings shown are based on an allowance of 1.333 in accordance with the factors shown in the I=B=R Code as published by The Hydronics Institute.

Selection of boiler size should be based upon "Net I=B=R Rating" being equal to or greater than installed radiation in square feet. Consult manufacturer before selecting a boiler for installations having unusual piping and pickup requirements.

Specifications and dimensions are subject to change without notice.

# Before You Start

Check to be sure you have the right size boiler before starting the installation. See rating and capacity table on previous page. Also be sure the new boiler is for the type of gas you are using. Check the rating plate on the right side of the boiler.

You must see that the boiler is supplied with the correct type of gas, fresh air for combustion, and a suitable electrical supply. Also, the boiler must be connected to a suitable venting system and an adequate piping system. Finally, a thermostat, properly located, is needed for control of the heating system. If you have any doubts as to the various requirements, check with local authorities and obtain professional help where needed. Take the time to complete all of the steps for SAFE and PROPER operation of the heating system.

If this boiler is installed in a building under construction, special care must be taken to insure a clean combustion air supply during the construction process. Airborne particulates such as from drywall dust and from fiberglass insulation can clog the burner ports and cause incomplete combustion and sooting.

These boilers are designed for use in closed heating systems where all of the

steam is returned to the boiler as condensate and the amount of make-up water required is minimal. These boilers are not designed for or intended for use in open systems of process applications using 100% make-up water. Damage to the boiler resulting from such use shall not be covered under the warranty.

Where required by the authority having jurisdiction, the installation must conform to American Society of Mechanical Engineers Safety Code for Controls and Safety Devices for Automatically Fired Boilers, No. CSD-1.

The installation must conform to the requirements of the authority having jurisdiction or, in the absence of such requirements, to the National Fuel Gas Code, ANSI Z223.1-latest revision.

The following steps are all necessary for proper installation and safe operation of your boiler.

1. LOCATING THE BOILER
2. FRESH AIR FOR COMBUSTION
3. INSTALLATION - SYSTEM PIPING
4. CHIMNEY & VENT PIPE CONNECTION
5. GAS SUPPLY PIPING
6. ELECTRICAL WIRING
7. CHECKING & ADJUSTING

**KEEP BOILER AREA CLEAN AND FREE FROM COMBUSTIBLE MATERIALS, GASOLINE AND OTHER FLAMMABLE VAPORS AND LIQUIDS**

## Locating the Boiler

1. Select level location as centralized with piping system, and as near chimney as possible.
2. Place crated boiler at selected location, remove crate by pulling crate sides from top and bottom boards. Combustible floors: When boiler is to be installed on a combustible floor, a Special Base Plate must be used - 146-14-031 (2-6 Section) or 146-14-032 (7-9 Section). This boiler must not be installed on carpeting.
3. If this boiler is equipped with cast iron burners, it is also equipped with stainless steel wire ties to hold the back end of the cast iron burners in place during shipping. In order to remove the burners for cleaning or inspection, the wire ties must be cut and removed. The wire ties are accessed through the combustion air opening on the back side of the boiler at the bottom of the rear jacket panel, and may be cut with any wire cutting pliers. If the boiler is installed at its minimum clearances it may be difficult to reach the wire ties after the boiler is installed, and the wire ties should be cut now. The wire ties are only needed during shipping, and do not need to be replaced. **Boilers equipped with stainless steel burners do not have wire ties and this information does not apply.**
4. Boiler is to be level. Metal shims may be used under base legs for final leveling.
5. Equipment shall be installed in a location in which the facilities for ventilation permit satisfactory combustion of gas, proper venting, and maintenance of ambient temperature at safe limits under normal conditions of use. Equipment shall be located so as not to interfere with proper circulation of air. When normal infiltration does not provide the necessary air, outside air shall be introduced (See Page 4 - "Fresh Air for Combustion").
6. Advise owner to keep air passages free of obstructions. Ventilating and combustion air must enter boiler room without restrictions.

7. The boiler shall be installed such that the automatic gas ignition system components are protected from water (dripping, spraying, rain, etc.) during appliance operation and service (condensate trap, control replacement, etc.).

**FIG. 2 - MINIMUM CLEARANCE DIMENSIONS**

	Alcove, or Room Not Large In Comparison With Boiler	Room Large In Comparison With Boiler
Top	6"	6"
Rear	6"	6"
Control Side	7"	6"
Opposite Side	6"	6"
Front	18"	18"
Flue/Vent Connector	6"	6"
Near Boiler Piping	1"	1"

Boiler Size	Boiler Volume (Cu. Ft.)	Minimum Room Volume Required To Be Large Room (Cu. Ft.) *
3 sect.	6.3	100.4
4 sect.	8.1	129.4
5 sect.	9.9	158.4
6 sect.	11.7	187.4
7 sect.	13.5	216.4
8 sect.	15.3	245.4
9 sect.	17.2	274.5

\* FOR ROOM WITH SINGLE BOILER ONLY

THIS UNIT MUST BE SET ON A CONCRETE OR OTHER NON-COMBUSTIBLE MATERIAL BASE OR FLOOR.

# Fresh Air for Combustion

Provision for combustion and ventilation air must be in accordance with Section 5.3, Air for Combustion and Ventilation, of the National Fuel Gas Code, ANSI Z223.1-latest revision, or applicable provisions of the local building codes.

## WARNING

Be sure to provide enough fresh air for combustion. Enough air insures proper combustion and **assures that no hazard will develop due to the lack of oxygen.**

You must provide for enough fresh air to assure proper combustion. The fire in the boiler uses oxygen. It must have a continuous supply. The air in a house contains only enough oxygen to supply the burner for a short time. Outside air must enter the house to replace that used by the burner. Study following examples 1 and 2 to determine your fresh air requirements.

### EXAMPLE 1: Boiler Located in Unconfined Space

An unconfined space is defined as a space whose volume is not less than 50 cubic feet per 1,000 Btu per hour of the total input rating of all appliances installed in that space.

If your boiler is in an open area (unpartitioned basement) in a conventional house, the air that leaks through the cracks around doors and windows will usually be adequate to provide air for combustion. The doors should not fit tightly. Do not caulk the cracks around the windows.

Equipment located in buildings of unusually tight construction shall be provided with air for combustion, ventilation, and dilution of flue gases using the methods described in example 2B or shall be specially engineered. The authority having jurisdiction must approve specially engineered installations.

### EXAMPLE 2: Boiler Located in Confined Space

**A. All Air from Inside the Building:** The confined space shall be provided with two permanent openings communicating directly with an additional room(s) of sufficient volume so that the combined volume of all spaces meets the criteria for an unconfined space. The total input of all gas utilization equipment installed in the combined space shall be considered in making this determination. Each opening shall have a minimum free area of one square inch per 1,000 Btu per hour of the total input rating of all gas utilization equipment in the confined space, but not less than 100 square inches. One opening shall be within 12 inches of the top and one within 12 inches of the bottom of the enclosure. The minimum dimension of air openings shall not be less than 3 inches.

**B. All Air from Outdoors:** The confined space shall communicate with the outdoors in accordance with methods 1 or 2. The minimum dimension of air openings shall not be less than 3 in. Where ducts are used, they shall be of the same cross-sectional area as the free area of the openings to which they connect.

1. Two permanent openings, one commencing within 12 inches of the top, and one commencing within 12 inches of the bottom, of the enclosure shall be provided. The openings shall communicate directly, or by the ducts, with the outdoors or spaces (crawl or attic) that freely communicate with the outdoors.
  - a) Where directly communicating with the outdoors or where communicating to the outdoors through vertical ducts, each opening shall have a minimum free area of 1 sq. in. per 4000 Btu per hour of total input rating of all equipment in the enclosure. (See Figure 3A.)
  - b) Where communicating with the outdoors through horizontal ducts, each opening shall have a minimum free area of 1 sq. in. per 2000 Btu per hour of total input rating of all equipment in the enclosure. (See Figure 3B.)
2. One permanent opening commencing with 12 inches of the top of the enclosure, shall be permitted where the equipment has clearance of at

## NOTE

If you use a fireplace or a kitchen or bathroom exhaust fan, you should install an outside air intake. These devices will rob the boiler and water heater of combustion air.

least 1 inch from the sides and back and 6 inches from the front of the appliance. The opening shall directly communicate with the outdoors or shall communicate through a vertical or horizontal duct to the outdoors or spaces (crawl or attic) that freely communicate with the outdoors, and shall have a minimum free area of:

- a) 1 sq. inch per 3000 Btu per hour of the total input of all equipment located in the enclosure (See Figure 4), and
- b) Not less than the sum of the areas of all vent connectors in the confined space.

**Figure 3A - FRESH AIR DUCT CAPACITIES (Btuh)**

1 Square Inch per 4,000 Btuh

	100% Free Area	75% Free Area	25% Free Area
Fresh Air Duct Size	¼" Wire Mesh	Metal Louvers	Wood Louvers
3" x 12"	144,000	108,000	36,000
8" x 8"	256,000	192,000	64,000
8" x 12"	384,000	288,000	96,000
8½" x 16"	512,000	384,000	128,000

**Figure 3B - FRESH AIR DUCT CAPACITIES (Btuh)**

1 Square Inch per 2,000 Btuh

	100% Free Area	75% Free Area	25% Free Area
Fresh Air Duct Size	¼" Wire Mesh	Metal Louvers	Wood Louvers
3" x 12"	72,000	54,000	18,000
8" x 8"	128,000	96,000	32,000
8" x 12"	192,000	144,000	48,000
8½" x 16"	256,000	192,000	64,000

**Figure 4 - FRESH AIR DUCT CAPACITIES (Btuh)**

1 Square Inch per 3,000 Btuh

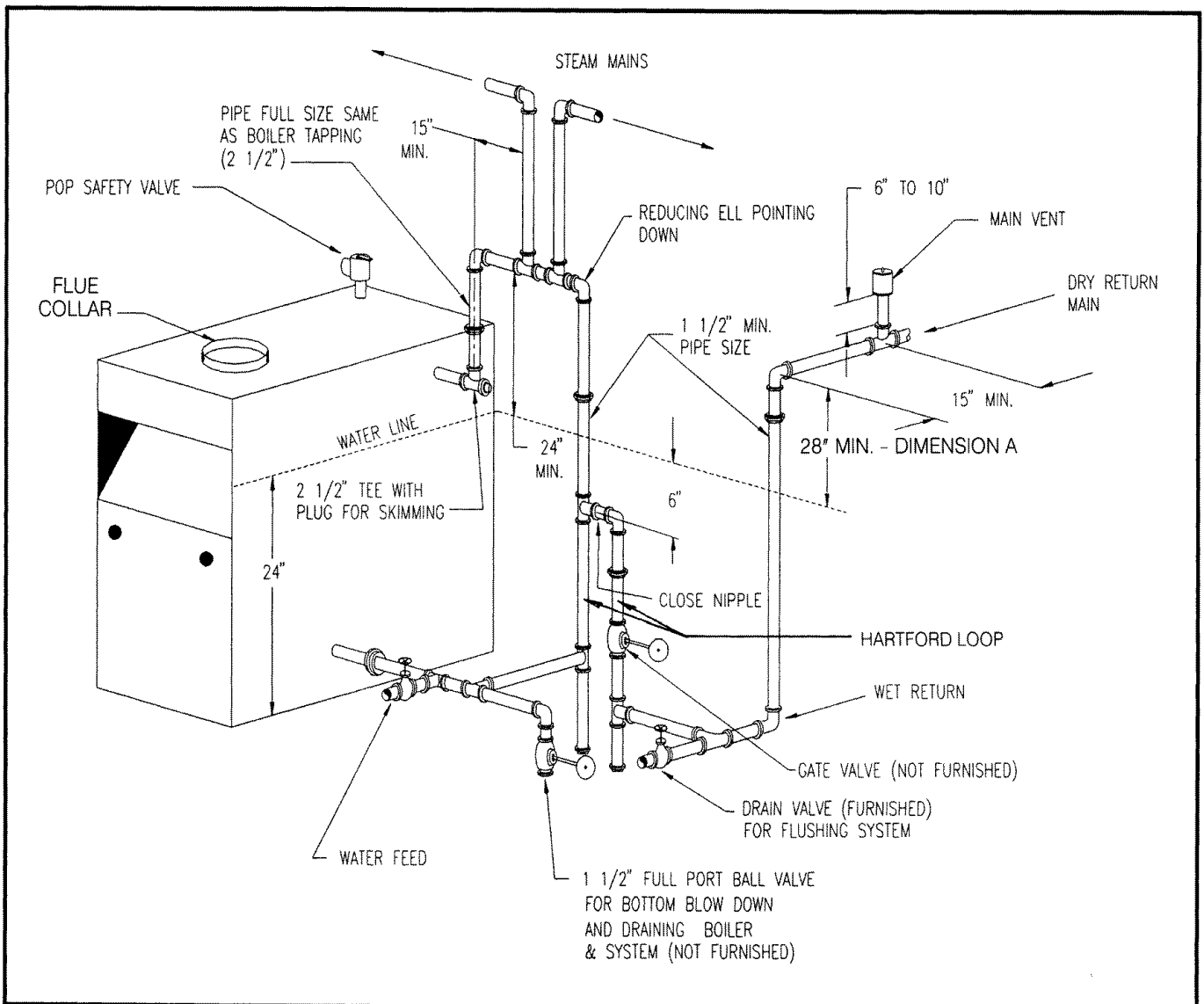
	100% Free Area	75% Free Area	25% Free Area
Fresh Air Duct Size	¼" Wire Mesh	Metal Louvers	Wood Louvers
3" x 12"	108,000	81,000	27,000
8" x 8"	192,000	144,000	48,000
8" x 12"	288,000	216,000	72,000
8½" x 16"	384,000	288,000	96,000

# Installation - System Piping

The near boiler piping, that is the piping around the boiler, must be considered as part of the boiler for proper water level control, and to produce dry steam. Correct near boiler piping is crucial to the proper operation of the boiler and the heating system. Follow these recommendations carefully.

1. Place boiler in selected location, as near chimney as possible.
2. Install the pop safety valve, using the furnished 3/4" coupling, into the 3/4" pipe nipple on the top of the boiler. Make a discharge pipe, using 3/4" pipe (not furnished) to carry the water or steam to a nearby drain. Do not connect the discharge pipe directly to a drain but leave an air gap. The downstream end of the discharge pipe must be unthreaded. No shutoff of any description shall be placed between the pop safety valve and the boiler,
- or on discharge pipes between such safety valves and the atmosphere. Installation of the pop safety valve shall conform to the requirements of the ANSI/ASME Boiler and Pressure Vessel Code, Section IV. The manufacturer is not responsible for any water damage.
3. This boiler is equipped with two 2 1/2" supply connections and two 2 1/2" return connections, one each on both the left and right sides of the boiler. Unused connections must be plugged with the 2 1/2" plugs (furnished).
4. Recommended near boiler piping for gravity return systems is shown in Figure 5. This configuration uses one supply and one return tapping. This setup can be used on any size boiler in this series. The supply and return connections may be piped both into the same side (either left or right) or one into each side of the boiler.

FIG. 5 - RECOMMENDED NEAR BOILER PIPING USING ONE SUPPLY TAPPING



5. For installers choosing to use both supply tappings, Figure 6A shows the **correct** way to pipe this system. Figure 6B shows the **wrong** way to pipe a header with two risers.
  - Headers must be fitted with header offsets or swing joints, or be equipped with expansion joints, so that thermal expansion and contraction of the header will not damage the boiler. Headers shall not be welded.
  - System takeoffs from the header must be between the equalizer and the riser to the header nearest the equalizer. System takeoffs must never be between two risers.
6. System takeoffs from the header must never be bul-headed. If the steam main goes in two directions, there must be two takeoffs from the header, one for each main.
7. All boilers in gravity return systems **must** be equipped with a Hartford Loop as shown in Figures 5 and 6A.
8. When piping the vertical risers from the boiler to the header, the bottom of the header must be a minimum of 24 inches above the water level line on the right side of the boiler.
9. Steam riser(s) and header shall be 2½" pipe size.
10. Equalizer line shall be minimum 1½" pipe size.
11. The near boiler piping shall include a 2½" tee with a plug located on the supply line as shown for skimming (i.e. surface blowdown).

FIG. 6A - RECOMMENDED NEAR BOILER PIPING USING TWO SUPPLY TAPPINGS

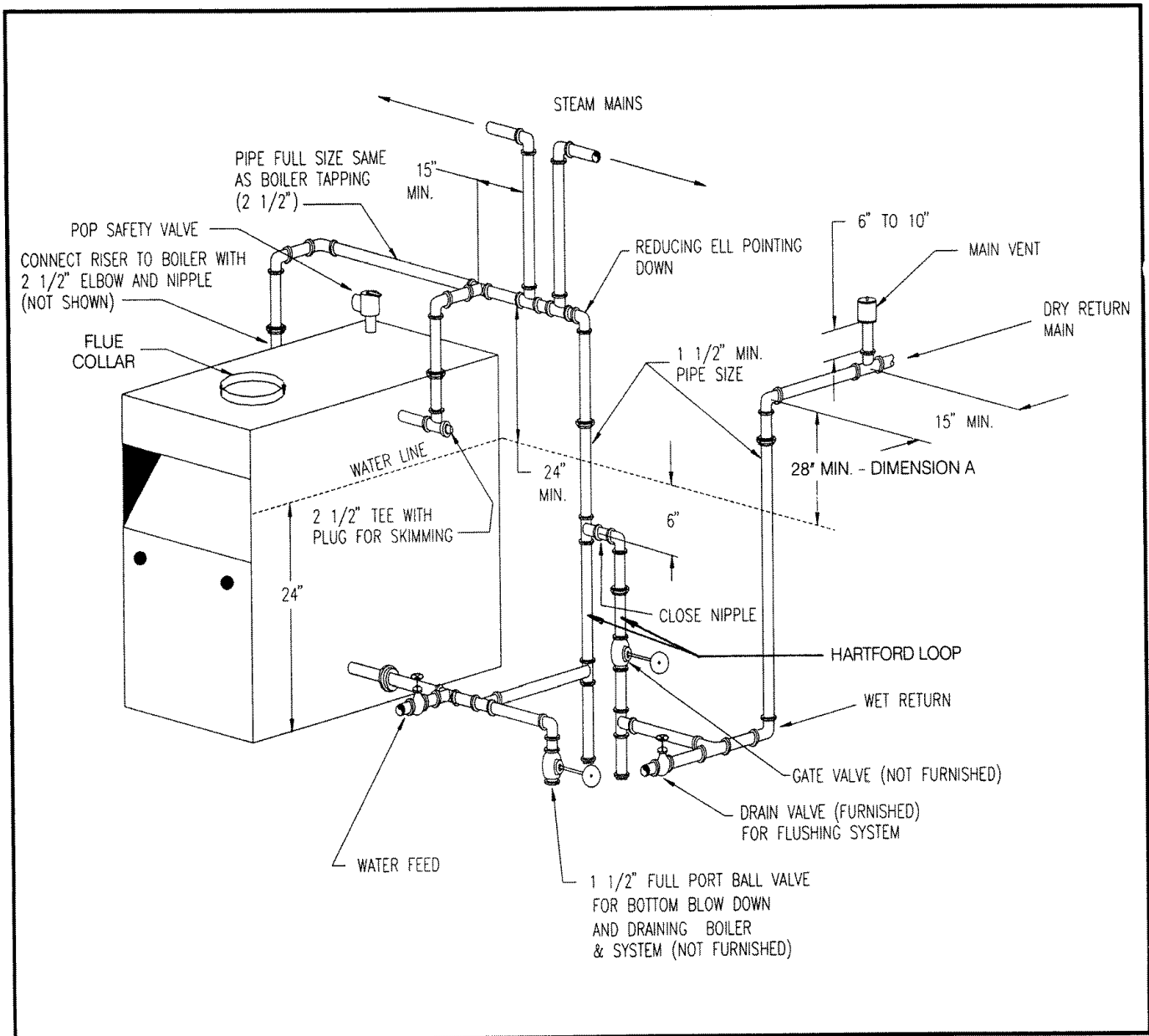
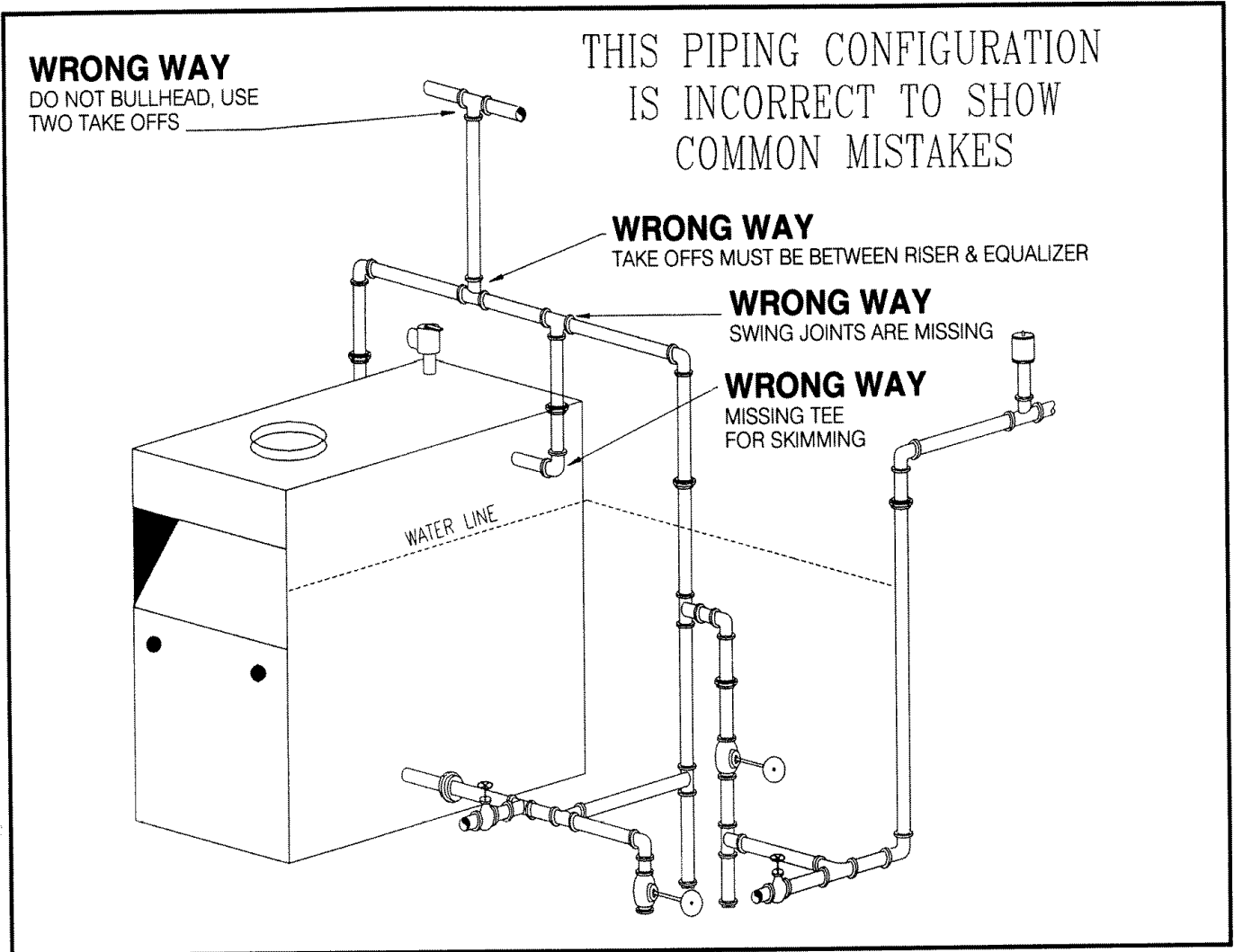


FIG. 6B - COMMON NEAR BOILER PIPING MISTAKES



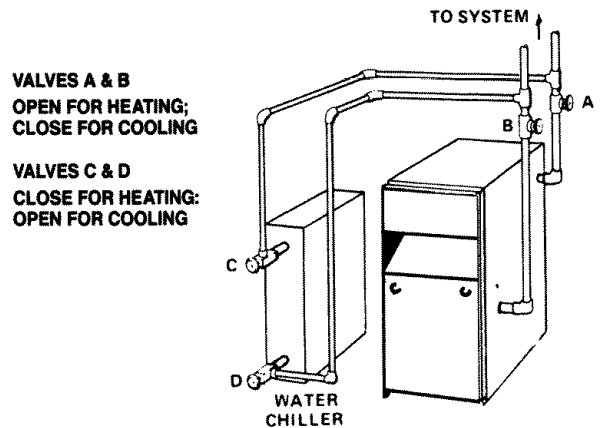
12. The near boiler piping shall include a 1½" ball valve in the return piping as shown for bottom blowdown and draining.
13. For gravity return systems, the bottom of the lowest steam carrying pipe, be it a dry return, or the end of the steam main, must be at least 28" above the normal water level line on the right side of the boiler. This is known as "Dimension A."
14. For pumped return systems, follow the condensate pump or boiler feed pump manufacturer's instructions for proper installation and hookup.
15. In connecting the cold water supply to the water inlet valve, make sure that a clean water supply is available. When the water supply is from a well or pump, a sand strainer should be installed at the pump.

**FOR USE WITH COOLING UNITS**

A. This boiler, when used in connection with chilled water systems, must be installed so that the chilled water is piped in parallel with the heating boiler. Appropriate valves must be used to prevent the chilled water from entering the heating boiler (Fig. 7).

B. When this boiler is connected to heating coils located in air handling units where they may be exposed to refrigerated air circulation, the piping system shall be equipped with flow control valves or other automatic means to prevent gravity circulation of the boiler water during the cooling cycle.

FIG. 7 - CHILLED WATER PIPING



# Chimney and Vent Pipe Connection

**For boilers for connection to gas vents or chimneys, vent installations shall be in accordance with Part 7, Venting of Equipment, of the National Fuel Gas Code, ANSI Z223.1-latest revision and applicable provisions of the local building codes.**

## CHECK YOUR CHIMNEY

This is a very important part of your heating system. It must be clean, the right size, properly constructed and in GOOD CONDITION. No boiler can function properly with a bad chimney. Inspect the chimney and verify that the construction and size of the chimney meets all applicable provisions of the National Fuel Gas Code and local building codes. Fig. 8 gives you an idea how a boiler might be vented to a chimney. Note that the height (HT) is measured from the vent pipe to the top.

## CHIMNEY SIZING

Chimney sizing and all other aspects of the vent installation must be in accordance with Part 7 of the National Fuel Gas Code, ANSI Z223.1-latest revision, and applicable provisions of the local building codes.

## CONNECTING THE VENT DAMPER AND VENT CONNECTOR

Refer to Fig. 1 flue diagram for the size and location of the vent (flue opening). Use a 28 gauge (minimum) galvanized pipe to connect to the chimney.

**IMPORTANT** – The damper blade on the furnished vent damper has a ½ square inch hole (approximately ¾" diameter). On boilers equipped with standing pilot, the hole **must** be left open. On boilers equipped with intermittent ignition, the hole should be plugged by using the plug supplied with the vent damper.

1. Position furnished vent damper on top of flue outlet collar. Fasten damper securely to flue outlet collar with sheet metal screws. Make sure damper blade has clearance to operate inside of diverter.

### As An Option

The damper may be installed in any horizontal or vertical position, closer to the flue outlet collar preferred. Follow the diagrams – Figures 9, 10 and 11.

2. Install the vent damper to service only the single boiler for which it is intended. The damper position indicator shall be in a visible location following installation. Locate the damper so that it is accessible for servicing.
3. The damper must be in the open position when appliance main burners are operating.
4. The boiler is equipped with a factory wired harness that plugs into the vent damper. The thermostat must be connected to the black wires marked 24 volt thermostat on the boiler.
5. Vent pipe must be same size as the flue outlet collar.
6. Slope pipe up from boiler to chimney not less than ¼" per foot.

7. Run pipe as directly as possible with as few elbows as possible.
8. Do not connect to fireplace flue.
9. End of vent pipe must be flush with inside face of chimney flue. Use a sealed-in thimble for the chimney connection.
10. Horizontal run should not be longer than ¾ the chimney height (HT) (Fig. 8).

The sections of vent pipe should be fastened with sheet metal screws to make the piping rigid. Horizontal portions of the vent system must be supported to prevent sagging. Use stovepipe wires every 5' to support the pipe from above. If the vent pipe must go through a crawl space, double wall vent pipe should be used. Where vent pipe passes through a combustible wall or partition, use a ventilated metal thimble. The thimble should be 4 inches larger in diameter than the vent pipe.

## MINIMUM VENT PIPE CLEARANCE

Wood and other combustible materials must not be closer than 6" from any surface of single wall metal vent pipe. Listed Type B vent pipe or other listed venting systems shall be installed in accordance with their listing.

## REMOVING EXISTING BOILER FROM COMMON VENTING SYSTEM

When an existing boiler is removed from a common venting system, the common venting system is likely to be too large for proper venting of the appliances remaining connected to it.

At the time of removal of an existing boiler, the following steps shall be followed with each appliance remaining connected to the common venting system placed in operation, while the other appliances remaining connected to the common venting system are not in operation.

1. Seal any unused openings in the common venting system.
2. Visually inspect the venting system for proper size and horizontal pitch and determine there is no blockage or restriction, leakage, corrosion and other deficiencies which could cause an unsafe condition.
3. Insofar as is practical, close all building doors and windows and all doors between the space in which the appliances remaining connected to the common venting system are located and other spaces of the building. Turn on clothes dryers and any appliance not connected to the common venting system. Turn on any exhaust fans, such as range hoods and bathroom exhausts, so they will operate at maximum speed. Do not operate a summer exhaust fan. Close fireplace dampers.

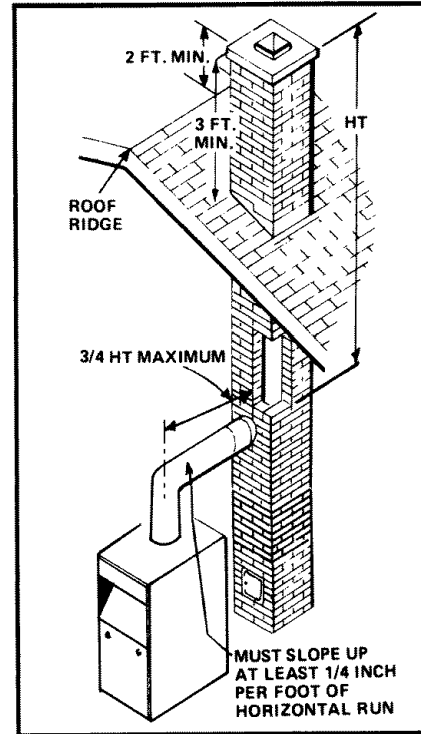


4. Place in operation the appliance being inspected. Follow the lighting instructions. Adjust thermostat so appliance will operate continuously.
5. Test for spillage at the draft hood relief opening after 5 minutes of main burner operation. Use the flame of a match or candle, or smoke from a cigarette, cigar or pipe.
6. After it has been determined that each appliance remaining connected to the common venting system properly vents when tested as outlined above, return doors, windows, exhaust fans, fireplace dampers and any other gas-burning appliance to their previous conditions of use.
7. Any improper operation of the common venting system should be corrected so the installation conforms with the National Fuel Gas Code, ANSI Z223.1-latest revision. When resizing any portion of the common venting system, the common venting system should be resized to approach the minimum size as determined using the appropriate tables in Part 11 in the National Fuel Gas Code, ANSI Z223.1-latest revision.

**For boilers for connection to gas vents or chimneys, vent installations shall be in accordance with Part 7, Venting of Equipment, of the National Fuel Gas Code, ANSI Z223.1-latest revision and applicable provisions of the local building codes.**

**Vent connectors serving appliances vented by natural draft shall not be connected into any portion of mechanical draft systems operating under positive pressure.**

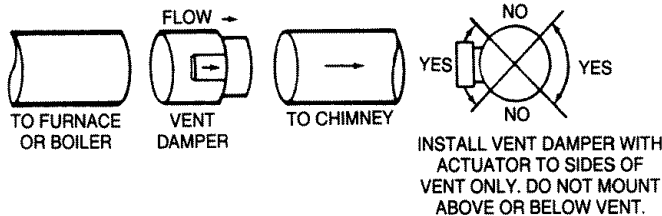
**FIG. 8  
TYPICAL MASONRY CHIMNEY REQUIREMENTS**



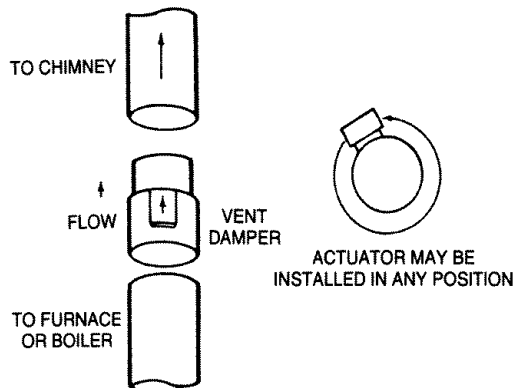
## Vent Damper Operation

**FIG. 9**

### HORIZONTAL INSTALLATION

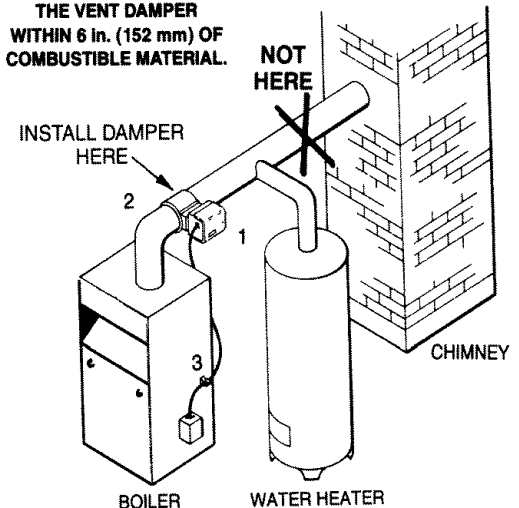


### VERTICAL INSTALLATION



**FIG. 10**

**CAUTION: DO NOT INSTALL THE VENT DAMPER WITHIN 6 in. (152 mm) OF COMBUSTIBLE MATERIAL.**



### TYPICAL INSTALLATION FOR VENT DAMPER NOTE CAUTION AND FOOTNOTES

1. Install the vent damper to service only the single appliance for which it is intended. If improperly installed, a hazardous condition, such as an explosion or carbon monoxide poisoning, could result.
2. Do not install the vent damper on vent pipe curve.
3. Do not run wires near high temperature surfaces. Use stand-off brackets if necessary.

For safe, efficient operation, the vent damper and all flue product carrying areas of the appliance must be checked annually by you, with particular attention given to deterioration from corrosion or other sources. If you see corrosion or other deterioration, contact your heating contractor for repairs. Check vent damper operation as follows:

1. When the boiler is off, check that the vent damper positions indicator points to the closed position, Fig. 11.
2. Turn the thermostat or controller up to call for heat and check the vent damper indicator points to the open position, Fig. 11.
3. Turn the thermostat or controller down again and check that the damper position indicator returns to the closed position.
4. If you have central air conditioning, set the thermostat to COOL and turn it down to call for cooling. Cooling system should operate.
5. Return thermostat to desired position.

**The vent damper must be inspected at least once a year by a trained, experienced service technician. The name of the person who originally installed your vent damper is shown on the installation label.**

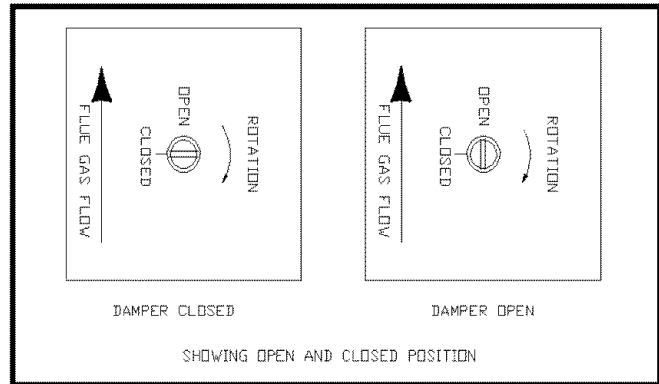
### MANUAL OPERATION OF THE VENT DAMPER

The vent damper may be placed in the open position to permit burner operation by using the "HOLD DAMPER OPEN" switch, located on the damper controller. The thermostat will control the burner firing as before, while the damper will remain open.

**DO NOT** turn damper open manually or motor damage will result. Set switch to "AUTOMATIC OPERATION" to close vent damper during burner off cycle.

For further information, and for a vent damper troubleshooting guide, refer to the manual that was packaged with the vent damper.

**FIG. 11  
VENT DAMPER POSITION INDICATOR**



## Gas Supply Piping

### CHECK GAS SUPPLY

The gas pipe to your boiler must be the correct size for the length of the run and for the BTU per hour input of all gas utilization equipment connected to it. See Fig. 12 for the proper size. Be sure your gas line complies with local codes and gas company requirements.

The boiler and its individual shut-off valve must be disconnected from the gas supply piping system during any pressure testing of that system at test pressures in excess of ½ psig (3.5 kPa).

This boiler must be isolated from the gas supply piping system by closing its individual manual shut-off valve during any pressure testing of the gas supply piping system at test pressures equal to or less than ½ psig (3.5 kPa).

### CONNECTING THE GAS PIPING

Refer to Fig. 13 for the general layout at the boiler. It shows the basic fittings you will need. The gas line enters the boiler from the right side.

The following rules apply:

1. Use only those piping materials and joining methods listed as acceptable by the authority having jurisdiction, or in the absence of such requirements, by the National Fuel Gas Code, ANSI Z223.1-latest revision.
2. Use pipe joint compound suitable for LP gas on male threads only.

3. Use ground joint unions.
4. Install a sediment trap upstream of gas controls.
5. Use two pipe wrenches when making the connection to the gas valve to keep it from turning.
6. Install a manual shut-off valve in vertical pipe about 5 feet above floor.
7. Tighten all joints securely.
8. Propane - gas connections should only be made by a licensed propane installer.
9. Two-stage regulation should be used by the propane installer.
10. Propane - gas piping should be checked out by the propane installer.

### CHECKING THE GAS PIPING

Upon completion of piping, check immediately for gas leaks. Open the manual shut-off valve. Test for leaks by applying soap suds (or a liquid detergent) to each joint. Bubbles forming indicate a leak. **CORRECT EVEN THE SMALLEST LEAK AT ONCE.**

### WARNING

Never use a match or open flame to test for leaks

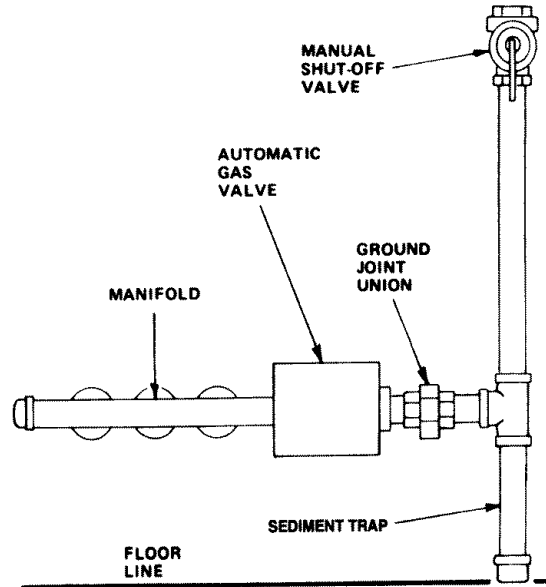
**FIG. 12 - GAS PIPE SIZES**

NATURAL GAS				
Length of Pipe - Ft.	Pipe Capacity - BTU Per Hour Input Includes Fittings			
	1/2"	3/4"	1"	1 1/4"
20	92,000	190,000	350,000	625,000
40	63,000	130,000	245,000	445,000
60	50,000	105,000	195,000	365,000

PROPANE GAS				
Length of Pipe - Ft.	Pipe Capacity - BTU Per Hour Input Includes Fittings			
	Copper Tubing*		Iron Pipe	
	5/8"	3/4"	1/2"	3/4"
20	131,000	216,000	189,000	393,000
40	90,000	145,000	129,000	267,000
60	72,000	121,000	103,000	217,000

\*Outside diameter  
The length of pipe or tubing should be measured from the gas meter or propane second stage regulator.

**FIG. 13 - GAS PIPING AT BOILER**



# Electrical Wiring

## ELECTRIC POWER SUPPLY

All electrical work must conform to local codes, as well as the National Electrical Code, ANSI/NFPA-70, latest revision.

Run a separate 120 volt circuit from a separate overcurrent protective device in your electrical service entrance panel. This should be a 15 ampere circuit. Locate a shut-off switch at the boiler. It must be turned off during any maintenance. Connect 120 volt electrical supply to the primary leads on the 24 volt transformer. Solder and tape or securely fasten these connections with wire nuts.

The boiler, when installed, must be electrically grounded in accordance with the requirements of the authority having jurisdiction or, in the absence of such requirements, with the National Electrical Code, ANSI/NFPA No. 70-latest revision. Run a 14 gauge or heavier copper wire from the boiler to a grounded connection in the service panel or a properly driven and electrically grounded ground rod.

### WARNING

Turn off electric power at fuse box before making any line voltage connections. Follow local electrical codes.

## INSTALL YOUR THERMOSTAT

The thermostat location has an important effect on the operation of your boiler system. BE SURE TO FOLLOW THE INSTRUCTIONS INCLUDED WITH YOUR THERMOSTAT.

Locate the thermostat about five feet above the floor on an inside wall. It may be mounted directly on the wall or on a vertically mounted outlet box. It should be sensing average room temperature, so avoid the following:

### DEAD SPOTS:

- Behind doors
- Corners and alcoves

### HOT SPOTS:

- Concealed pipes
- Fireplace
- TV sets
- Radios
- Lamps
- Direct sunlight
- Kitchens

### COLD SPOTS:

- Concealed pipes or ducts
- Stairwells - drafts
- Doors - drafts
- Unheated rooms on other side of wall

Set heat anticipator at 0.4 amps for boilers equipped with standing pilot, and at 0.6 amps for boilers equipped with intermittent ignition. The 24 volt thermostat leads shall be connected to the two wires tagged "24 volt thermostat" on the boiler. For boilers with 67D-1 float type low water cut-off, the two wires are black. One wire is located on the secondary of the 24 volt transformer, the second wire is located on the pressure limit control. For boilers with PS-802 probe type low water cut-off, one wire is green and is located on terminal B of the PS-802, the second wire is black and located on the pressure limit control.

## ELECTRONIC THERMOSTATS

Certain types of electronic thermostats may lose their memory or shut down. With 67D-1 float type low water cut offs, this may occur each time the thermostat calls for heat, due to the internal circuit in the vent damper. With PS-802

probe type low water cut offs, this may occur each time the low water cut off detects a low water condition. If this is the case, an isolation relay is required for the thermostat circuit. A 24 volt single pole single throw (SPST) normally open (N.O.) relay is required, such as the Honeywell R8222A or equivalent. Wire as shown in Fig. 14A or Fig. 14B.

### VENT DAMPER

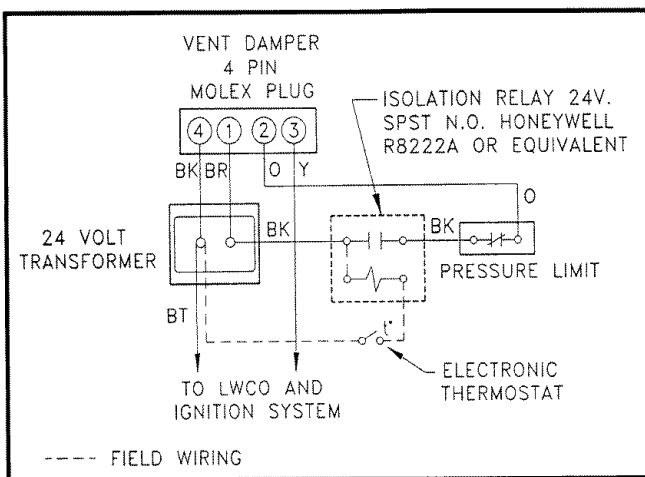
The boiler is equipped with a factory wired harness with 4 pin molex plug, that plugs into the 4 pin molex receptacle inside the vent damper operator.

The vent damper must be connected for the boiler to operate. Wiring diagrams follow for the various different models.

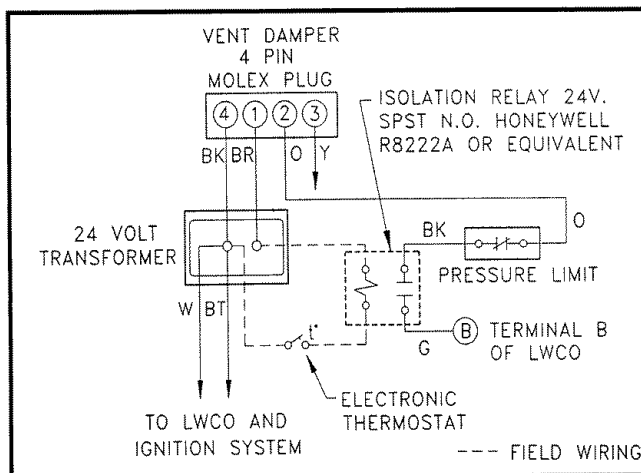
### CAUTION

**Label all wires prior to disconnection when servicing controls. Wiring errors can cause improper and dangerous operation. Verify proper operation after servicing.**

**FIG 14A - ISOLATION RELAY WIRING FOR STEAM BOILERS WITH FLOAT TYPE LOW WATER CUT OFF AND USING AN ELECTRONIC THERMOSTAT**

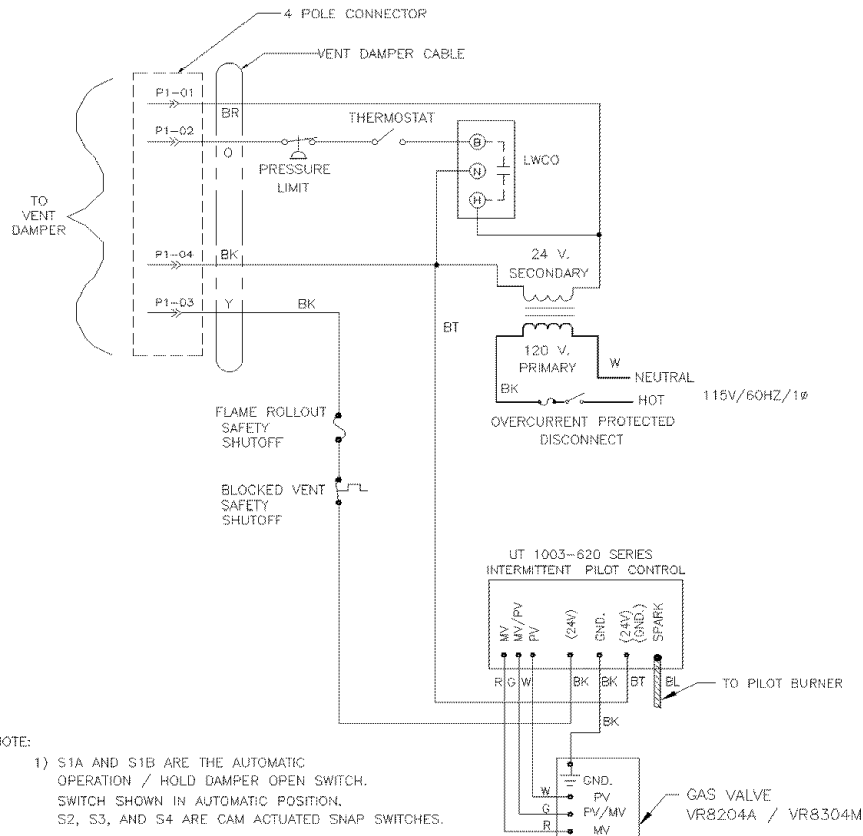
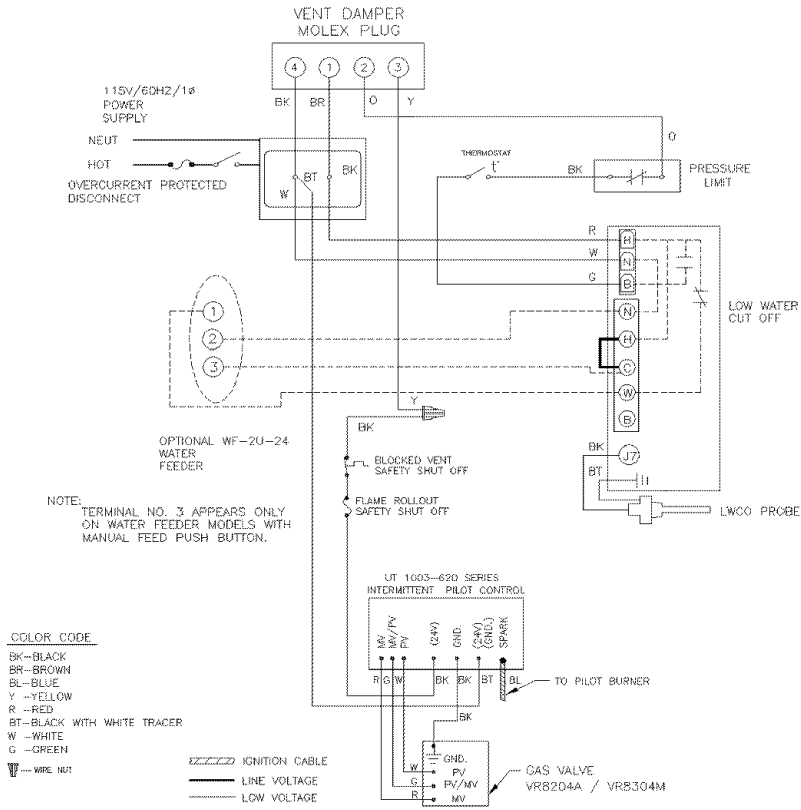


**FIG 14B - ISOLATION RELAY WIRING FOR STEAM BOILERS WITH PROBE TYPE LOW WATER CUT OFF AND USING AN ELECTRONIC THERMOSTAT**



# WIRING DIAGRAMS FOR BOILERS WITH PS-802 PROBE TYPE LOW WATER CUT-OFF

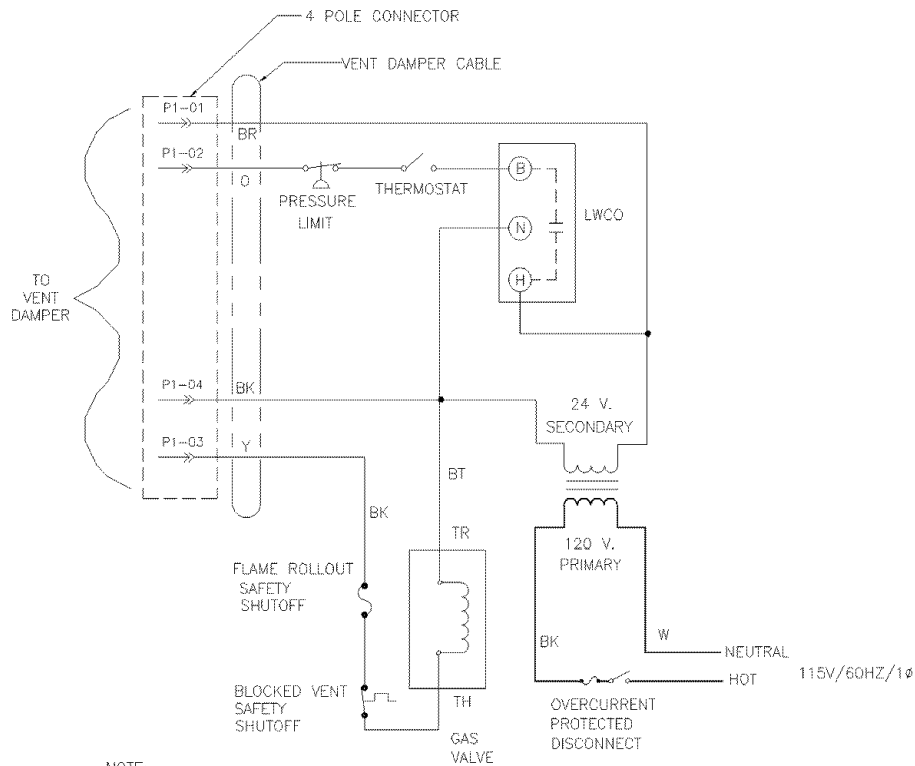
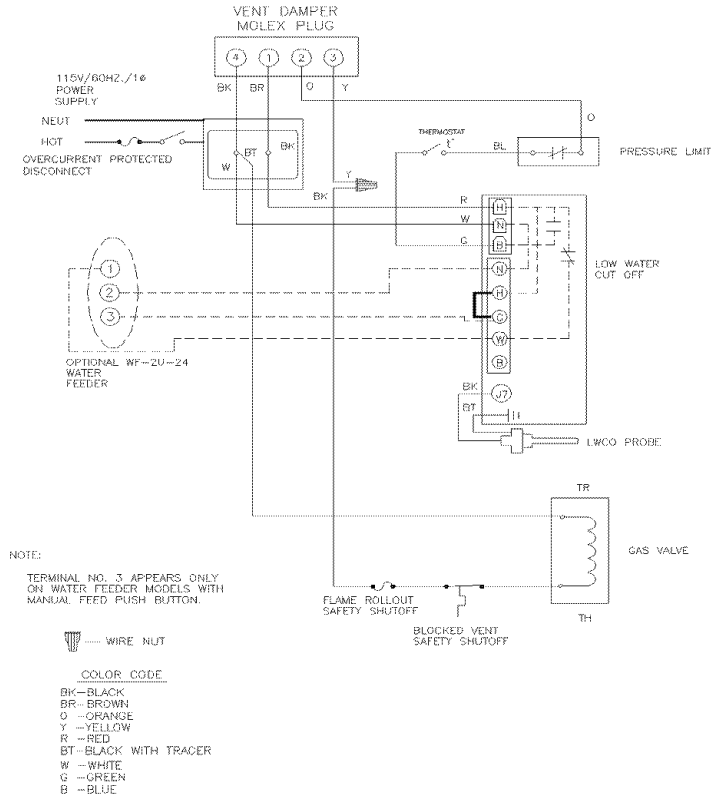
## INTERMITTENT IGNITION



**IF ANY OF THE ORIGINAL WIRE AS SUPPLIED WITH THIS APPLIANCE MUST BE REPLACED, IT MUST BE REPLACED WITH TYPE 105°C THERMOPLASTIC WIRE OR ITS EQUIVALENT.**

# WIRING DIAGRAMS FOR BOILERS WITH PS-802 PROBE TYPE LOW WATER CUT-OFF

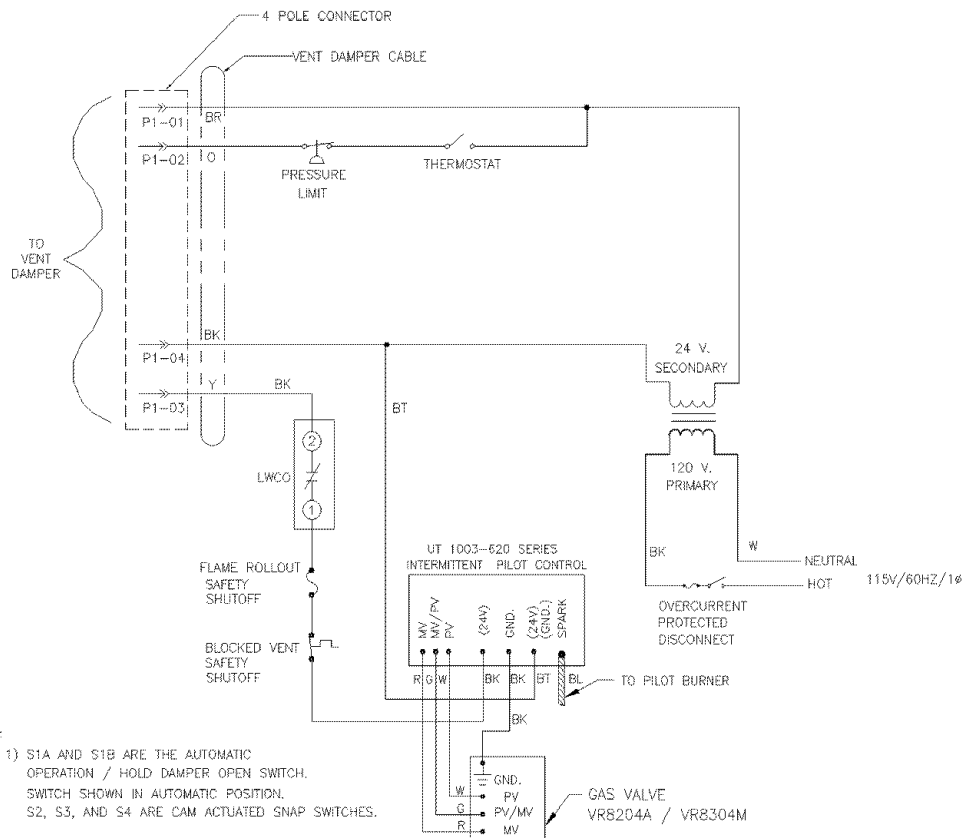
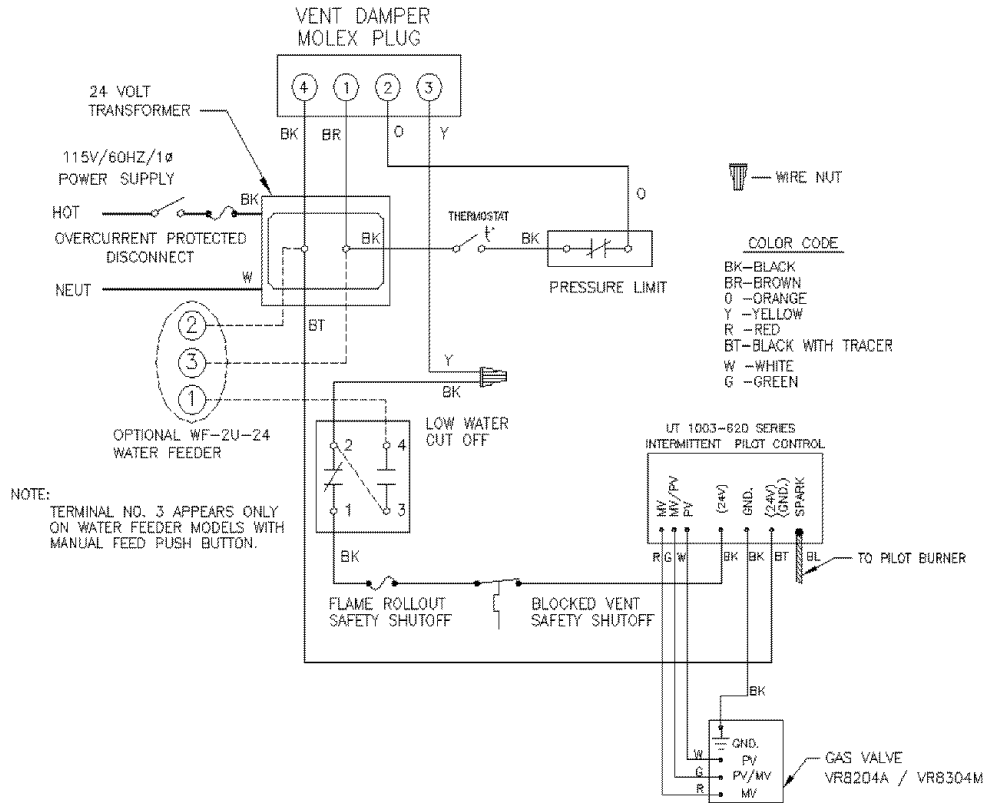
## STANDING PILOT



**IF ANY OF THE ORIGINAL WIRE AS SUPPLIED WITH THIS APPLIANCE MUST BE REPLACED, IT MUST BE REPLACED WITH TYPE 105°C THERMOPLASTIC WIRE OR ITS EQUIVALENT.**

# WIRING DIAGRAMS FOR BOILERS WITH 67D-1FLOAT TYPE LOW WATER CUT-OFF

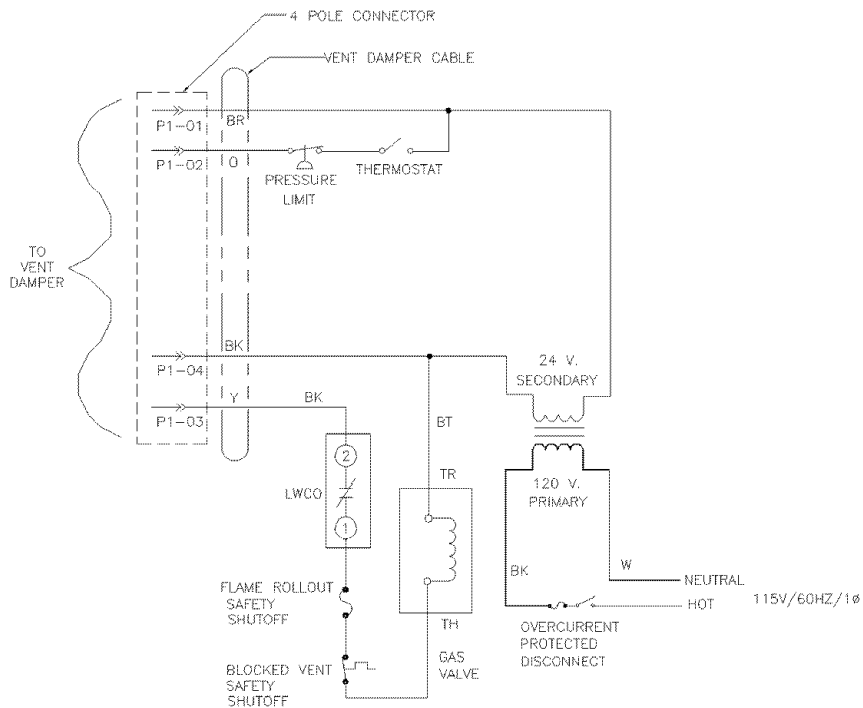
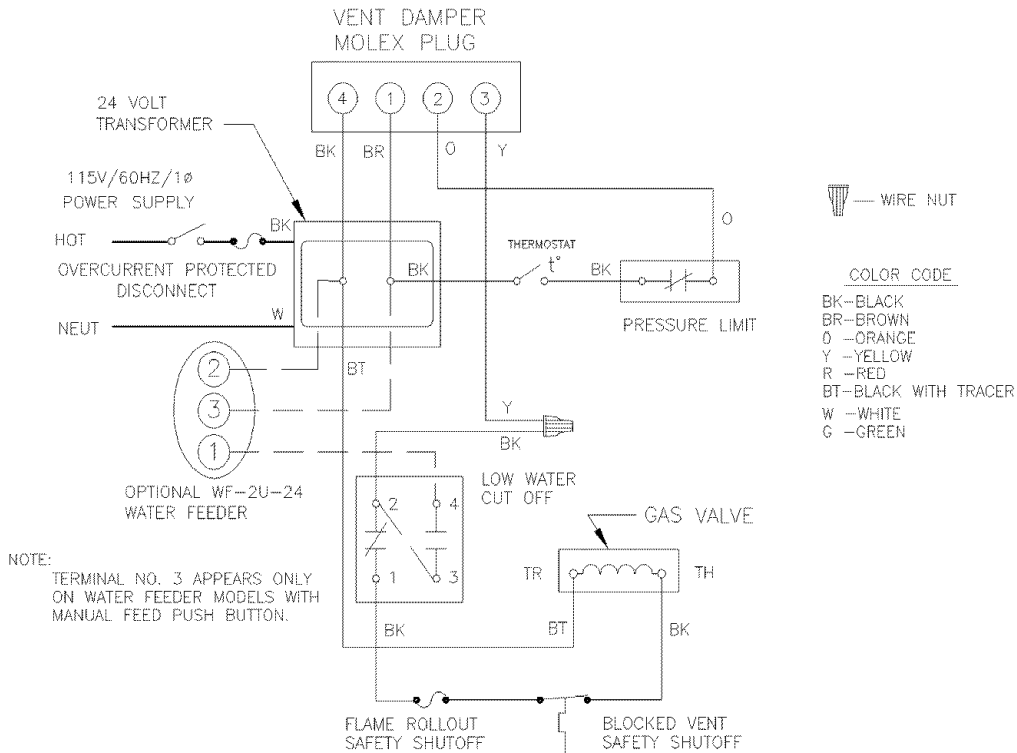
## INTERMITTENT IGNITION



**IF ANY OF THE ORIGINAL WIRE AS SUPPLIED WITH THIS APPLIANCE MUST BE REPLACED, IT MUST BE REPLACED WITH TYPE 105°C THERMOPLASTIC WIRE OR ITS EQUIVALENT.**

# WIRING DIAGRAMS FOR BOILERS WITH 67D-1FLOAT TYPE LOW WATER CUT-OFF

## STANDING PILOT



NOTE:

- 1) S1A AND S1B ARE THE AUTOMATIC OPERATION / HOLD DAMPER OPEN SWITCH. SWITCH SHOWN IN AUTOMATIC POSITION.
- 2, 3, AND 4 ARE CAM ACTUATED SNAP SWITCHES.

**IF ANY OF THE ORIGINAL WIRE AS SUPPLIED WITH THIS APPLIANCE MUST BE REPLACED, IT MUST BE REPLACED WITH TYPE 105°C THERMOPLASTIC WIRE OR ITS EQUIVALENT.**



# Controls and Accessories — What They Do

## POP SAFETY VALVE

The pop safety valve should open automatically if the boiler steam pressure exceeds the pressure rating of the valve (15 psig). Should it ever fail to open under this condition, shut down your boiler. If valve discharge occurs, or valve fails to open as described above, contact an authorized contractor or qualified service technician to replace the pop safety valve and inspect the heating system to determine the cause, as this may indicate an equipment malfunction.

Run a pipe from the safety valve outlet (pipe must be same size as outlet and open end must not be threaded) to an open drain, tub or sink, or other suitable drainage point not subject to freezing. Failure to do so may cause water damage or injury should relief valve release. Do not cap off the drain line from this valve!

## STEAM PRESSURE GAUGE

Every system should have a pressure gauge installed in the boiler. This gauge enables you to monitor the pressure in the system. If the safety devices fail to shut off your boiler at the proper settings, notify your serviceman immediately.

## WATER LEVEL GAUGE

The water level in the boiler can be seen through the glass tube in the water level gauge at side of boiler. Correct cold boiler water level is stamped on side jacket panel. The water level should be checked regularly for the proper level.

On the right side jacket panel of the boiler, there are three holes for the glass water level gauge. The top hole is common for both types of low water cut off, and is used for the upper gauge glass fitting. The middle hole, 9" down from the top hole, is used for the bottom gauge glass fitting for the Model 67D-1 and 47-2 float type low water cut off. The lowest hole, 12¼" down from the top hole, is used for the bottom gauge glass fitting for the Model PS-802 probe type low water cut off. The hole that is not being used is covered with a sheet metal knockout.

## STEAM PRESSURE CONTROL

The steam pressure limit control (pressuretrol) shuts off the gas to the main burners when the steam pressure in the boiler reaches the cut-off setpoint (i.e. the sum of the cut-in and the differential setpoints). Burners refire when the steam pressure drops to the cut-in setpoint. System pressure requirements are based on the size and condition of the pipes, and the load.

## LOW WATER CUT-OFF

### 1. Model 67D-1

This is a float operated switch which shuts down the gas burner if water falls below the visible bottom of the gauge glass.

### 2. Model PS-802

This is an electronic probe type LWCO. The probe is located inside the boiler. The LWCO will shut down the burners if the water loses contact with the probe for a period of 10 seconds.

Refer to manufacturer's instructions (enclosed) for more information.

## WATER FEEDER (Optional)

The Model WF-2U-24 water feeder may be used with either of the available low water cut-offs. The water feeder's job is to maintain a safe minimum water level. It's used to keep the boiler running by compensating for minor evaporative steam leaks, and to prevent freeze-ups if the homeowners are away and a return line should spring a leak.

McDonnell and Miller Model 101 water feeders may be used, however the water feed rates are too high and need to be regulated or throttled, and wiring will have to be revised. Consult the boiler manufacturer before using these or any other non-standard types of controls.

The automatic water feeder is a safety device, not a convenience item. It is not designed to maintain a "normal" water line. The water feeder does not take the place of a responsible person monitoring and maintaining the normal water line. Steam boilers require personal attention.

## VENT DAMPER

This is an automatic, motorized stack damper that has been developed to increase the efficiency of heating systems by reducing standby losses from the boiler and the conditioned air space. The damper closes the chimney vent when the burner is off and fully opens it when combustion is required.

## ROLLOUT SWITCH (FLAME ROLLOUT SAFETY SHUTOFF)

The rollout switch is a temperature-sensitive fuse link device. It is located on the boiler base just outside the fire box. In the event of heat exchanger flueway blockage causing flame to roll out of the fire box, the fuse will blow, shutting down the flow of gas to the main burners. The fuse does not change in appearance when blown.

If the rollout switch blows, it must be replaced with an exact replacement. Check heat exchanger flueways for blockage when restoring system to operating condition. Do not operate system without a rollout switch.

## SPILL SWITCH (BLOCKED VENT SAFETY SHUTOFF)

The spill switch is a manual reset disc thermostat with a fixed setpoint (280° F), and normally closed contacts. It is located at the relief opening of the draft diverter. In the event of chimney or venting system blockage causing products of combustion to spill out of the relief opening, the spill switch disc heats up and the spill switch contacts will open, shutting down the flow of gas to the main burners by removing power to the gas valve.

In the event that the spill switch contacts open, the reset button on the back of the switch will pop up. The spill switch must be reset manually, after the switch has cooled off, by pushing the reset button down. Check the venting system and chimney for blockage when restoring the system to operating condition. **DO NOT** operate the boiler without a spill switch.

# For Your Safety Read Before Operating

**WARNING: If you do not follow these instructions exactly, a fire or explosion may result causing property damage, personal injury or loss of life.**

- A. Some boilers are equipped with an intermittent ignition device which automatically lights the pilot. Do **not** try to light the pilot by hand.

Some boilers are equipped with a continuous pilot and must be manually lighted. (See lighting instructions on page 18-19.) A match holder is included in the parts bag.

- B. BEFORE OPERATING smell all around the appliance area for gas. Be sure to smell next to the floor because some gas is heavier than air and will settle on the floor.

#### WHAT TO DO IF YOU SMELL GAS

- Do not try to light any appliance.
- Do not touch any electric switch; do not use any phone in your building.

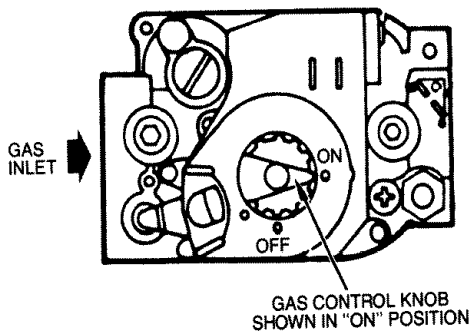
- Immediately call your gas supplier from a neighbor's phone. Follow the gas supplier's instructions.
- If you cannot reach your gas supplier, call the fire department.

- C. Use only your hand to push in or turn the gas control knob. Never use tools. If the knob will not push in or turn by hand, don't try to repair it, call a qualified service technician. Force or attempted repair may result in a fire or explosion.

- D. Do not use this appliance if any part has been under water. Immediately call a qualified service technician to inspect the appliance and to replace any part of the control system and any gas control which has been under water.

## Intermittent Ignition Boiler – VR8204A/VR8304M Gas Valve Operating Instructions

1. STOP! Read the safety information on this page.
2. Set the thermostat to lowest setting.
3. Turn off all electric power to the appliance.
4. This appliance is equipped with an ignition device which automatically lights the pilot. Do **not** try to light the pilot by hand.



5. Remove lower front panel.
6. Rotate the gas control knob clockwise to "OFF."

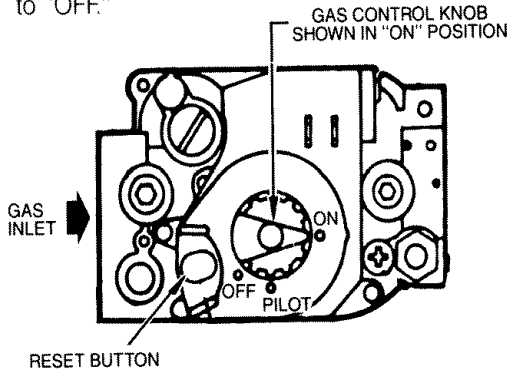
7. Wait five (5) minutes to clear out any gas. Then smell for gas, including near the floor. If you smell gas, STOP! Follow "B" in the safety information on this page. If you don't smell gas, go to next step.
8. Rotate the gas control knob counterclockwise to "ON."
9. Replace lower front panel.
10. Turn on all electric power to the appliance.
11. Set thermostat to desired setting.
12. If the appliance will not operate, follow the instructions "To Turn Off Gas To Appliance" and call your service technician or gas supplier.

#### TO TURN OFF GAS TO APPLIANCE

1. Set the thermostat to lowest setting.
2. Turn off all electric power to the appliance if service is to be performed.
3. Push in gas control knob slightly and turn clockwise to "OFF." Do not force.

# Continuous Pilot Boiler – VR8200A/VR8300A Gas Valve Operating Instructions

1. STOP! Read the safety information on page 18.
2. Set the thermostat to lowest setting.
3. Turn off all electric power to the appliance.
4. Remove lower front panel.
5. Rotate gas control knob slightly and turn clockwise to "OFF."



6. Wait five (5) minutes to clear out any gas. Then smell for gas, including near the floor. If you smell gas, STOP! Follow "B" in the safety information on page 18. If you don't smell gas, go to next step.
7. Find pilot – follow metal tube from gas control. The pilot is between two burner tubes as shown in Fig. 15.
8. Turn knob on gas control counterclockwise to "PILOT."

9. Rotate the gas control knob counterclockwise to "PILOT." Push down and hold the red reset button while you light pilot burner with a match. After about one minute, release reset button. Pilot should remain lit. If it goes out, turn gas control knob clockwise to OFF. To relight, repeat steps 5-9.

- If button does not pop up when released, stop and immediately call your service technician or gas supplier.
- If the pilot will not stay lit after several tries, turn the gas control knob to "OFF" and call your service technician or gas supplier.

10. After pilot remains lit when red reset button is released, turn gas control knob counterclockwise to "ON."
11. Replace lower front panel.
12. Turn on all electric power to the appliance.
13. Set thermostat to desired setting.

## TO TURN OFF GAS TO APPLIANCE

1. Set the thermostat to lowest setting.
2. Turn off all electric power to the appliance if service is to be performed.
3. Push in gas control knob slightly and turn clockwise to "OFF." Do not force.

FIG. 15 - LIGHTING PILOT

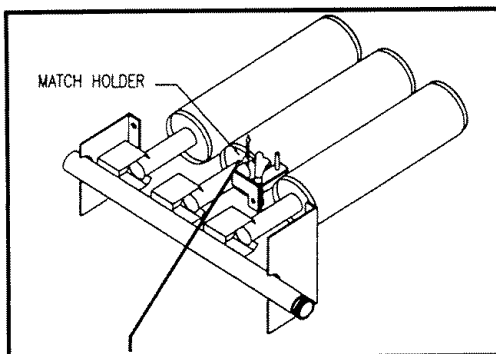


FIG. 16 - VR8200A VR8300A AUTOMATIC GAS VALVE

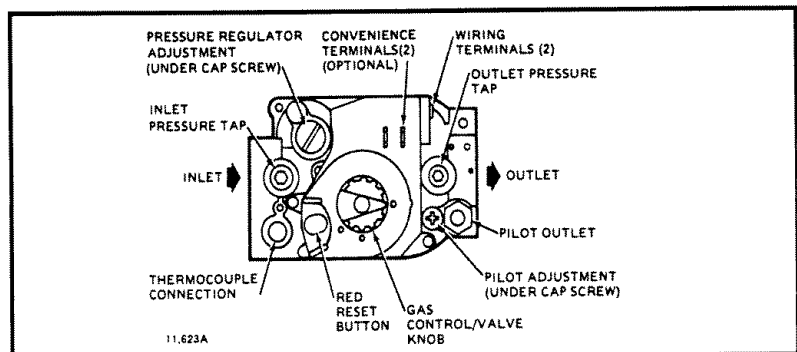
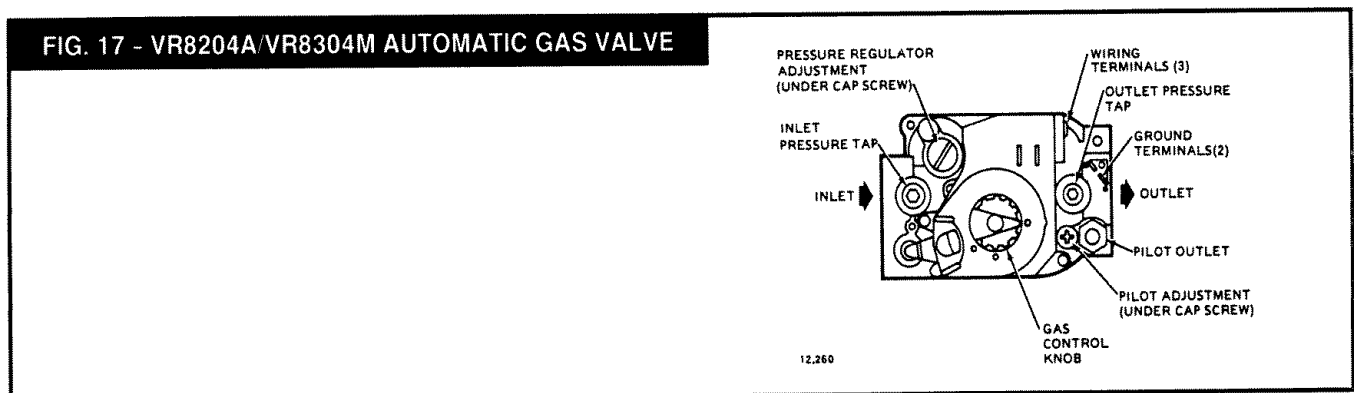


FIG. 17 - VR8204A/VR8304M AUTOMATIC GAS VALVE



# Operating Your Boiler

## HOW A STEAM SYSTEM OPERATES

The water in the boiler is heated until it reaches the boiling point. As the water boils it turns into steam. The steam rises from the top of the water through the supply main to the radiation units. As it passes through the radiators it releases its heat and condenses into water. The water returns to the boiler through the return main. Most residential systems operate at less than 1 pound steam pressure.

## FILLING SYSTEM WITH WATER

On steam heating systems the boiler is partially filled with water. It is very important to the proper operation of the entire system that your boiler be filled to the proper level. The correct water level is about halfway up the glass water level gauge as marked on the boiler jacket. To fill:

1. Close the boiler drain valve.
2. Open the valves at the top and bottom of the glass water level gauge. Also open the drain valve at the bottom of the gauge.
3. Open the fill valve and allow water to run into the boiler.

**WARNING - Never run water into a hot empty boiler.**

4. Allow boiler to fill until water runs out the gauge drain valve. Then close the gauge drain valve.
5. Continue to fill boiler until water reaches the indicated water line. This is about halfway up the glass tube.

## WATER LEVEL

The normal water level is shown on the right side of the boiler and is 24" above the floor. The normal water level is determined when the boiler is off and cold, i.e. when all of the water in the system is inside the boiler and the return piping below the water line, and everything above the water line is air, no steam. When the boiler is making steam, the water level will drop two to three inches below the normal water line.

## AUTOMATIC GAS VALVE

The Automatic Gas Valve opens or closes according to the heat requirements of the thermostat and temperature limit control. It closes if the pilot goes out. Each individual control must be operating correctly before any gas can pass to the burners. Any one control can hold the gas supply from burner regardless of the demand of any other control.

## THERMOSTAT

Keep it set at a desired room temperature. If windows are to be opened or heat is not needed, move thermostat pointer to a lower setting.

### NOTE

In the event of failure of any component, the system will not operate or will go into safety lockout. The system is completely self-checking. On every call for heat, each component must be functioning properly to permit operation. On safety lockout the system has to be reset by turning the thermostat to the lowest setting for one minute, then back to the normal setting.

Safe lighting and other performance criteria were met with the gas manifold and control assembly provided on the boiler when the boiler underwent tests specified in ANSI Z21.13 - latest revision.

# Checking and Adjusting

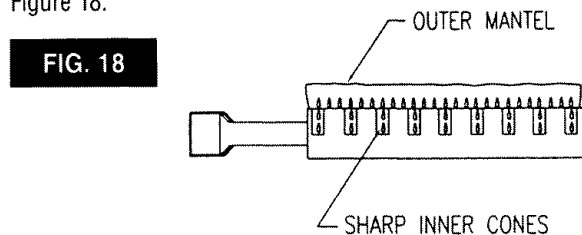
## ADJUST PILOT BURNER

Pilot flame should surround 3/8" to 1/2" of the pilot sensor. Refer to Fig. 19. If flame needs adjusting, do it as follows:

1. Remove screw cover over pilot adjusting screw.
2. Insert small screwdriver and adjust flame as needed. Turn screw counterclockwise to increase flame, clockwise to decrease.
3. Replace screw cover over pilot adjusting screw.

## MAIN BURNER(S)

The main burners do not require primary air adjustment and are not equipped with primary air shutters. Main burner flames should form sharp blue inner cones in a softer blue outer mantel, with no yellow. Puffs of air from blowing on the flame or stamping on the floor will cause the flames to turn orange momentarily. This is not unusual. Remain still when observing the main burner flames. If the flame appearance is not correct, check main burner orifices and the burner throat and flame ports for dust and lint obstruction. It may be necessary to remove the rollout shield to observe the main burner flames. Replace rollout shield after observation. Refer to Figure 18.



## GAS VALVE SAFETY SHUTDOWN TEST

1. For boilers equipped with continuous pilot, with main burners firing, disconnect the thermocouple from the gas valve. The gas valve should immediately shut off the main burners and the pilot.
2. For boilers equipped with intermittent ignition, with main burners firing, disconnect the ignition cable from the intermittent pilot control box. The gas valve should shut off the main burners. TURN OFF ELECTRIC POWER to boiler before reconnecting ignition cable, to prevent electric shock.

## ADJUST STEAM PRESSURE CONTROL

The steam pressure limit control (pressuretrol) shuts off the gas to the main burners when the steam pressure in the boiler reaches the cut-off setpoint (i.e. the sum of the cut-in and the differential setpoints). Burners refire when the steam pressure drops to the cut-in setpoint. System pressure requirements are based on the size and condition of the pipes, and the load.

For good system operation, the cut-in setting of the pressuretrol should never be less than twice the system pressure drop. In a typical single family residence with a clean one pipe heating system and cast iron radiation, this means that the cut-in will usually be set at the minimum setting, i.e. 1/2 psi.

Steam radiation is usually sized based on square feet of equivalent direct radiation (EDR). This is based on a steam pressure in the radiator of just less than 1 psi. Therefore, in our example system from above, we would set the

differential adjustment at 1 psi, i.e. the steam pressure required in the radiators. This will give us a cut-off setpoint of 1 1/2 psi.

The above is an example of a typical one pipe system. For larger systems or other types of systems such as two pipe systems, or systems with convectors or fan coil units, the pressuretrol settings will need to be determined on a system-by-system basis.

The cut-in setpoint is determined by the system pressure drop to the furthest radiator or terminal unit. Double the system pressure drop as a safety factor, resulting in the rule that the cut-in setting should never be less than twice the system pressure drop.

The differential setpoint is the steam pressure required at the terminal heating units.

Now your boiler will operate in the correct pressure range. It will maintain enough steam pressure to send the steam out to the furthest radiator, and not go over the optimum steam pressure that is required at the radiators.

## CHECKING CONTROLS

To check the Low Water Cut-Off, turn off power to the boiler or turn the thermostat down to the lowest setting. Drain water to below the visible bottom of the water gauge glass. Turn power on and turn the thermostat to call for heat. When the boiler is equipped with the float type LWCO, the gas valve should not open on a call for heat when the water is low. When the boiler is equipped with a probe type LWCO, the gas control should be powered for approximately 10 seconds (the time delay on the probe type LWCO), then the gas valve will close and the red indicator will illuminate on the LWCO.

If your boiler is equipped with the optional WF-2U-24 water feeder, continue to keep the thermostat calling for heat after the low water cut off recognizes the low water condition. After a one minute time delay, the water feeder should start feeding water to the boiler. The feeder should feed for one minute, and then go into another one minute waiting period. This cycle of alternately waiting and feeding should repeat until:

1. For Model 67D-1 float type low water cut offs - as the water level raises the float above the burner cut off switch level, the burners should ignite. The water feeder remains powered until the water level raises the float to the water feeder switch level, satisfying the water feeder.
2. For Model PS-802 probe type low water cut offs - the water level will rise until water in the boiler makes contact with the probe, satisfying the water feeder, and igniting the burners.

In either case, there should be between one and two inches of water visible in the gauge glass when both the water feeder is satisfied, and the burners are allowed to ignite.

The time delays in the feed cycles are designed to prevent the boiler from flooding due to slow return lines.

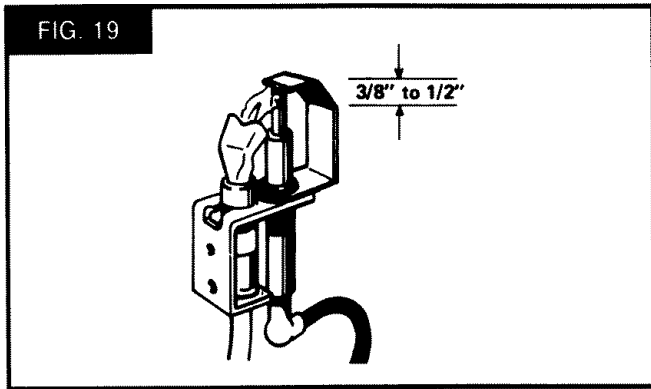
To check the pressure limit, run the boiler until the pressure reaches system demand. Then turn the pressure screw and

drop the pressure setting until the boiler shuts down. This will show that the pressure limit is operating properly.

Refer to control manufacturer's instructions (enclosed) for more information.

Check thermostat operation. When set above temperature indicated on the thermometer, boiler should ignite. Make certain the thermostat turns off the boiler when room temperature reaches the selected setting and starts the boiler operating when room temperature falls a few degrees.

Finally, set the thermostat for the desired temperature. Special conditions in your home and the location of the thermostat will govern this setting.



## Cleaning Your Boiler

It is very important to clean a new steam boiler after it has been installed and put into continuous operation. This must be done to remove any accumulation of oil, grease, sludge, etc., that may have been present in the system. These substances may cause the boiler water to foam and surge, thus producing a very unsteady water line, throwing water into the steam header, and possibly preventing steam generation. Follow these steps in order to remove these contaminants.

### SKIMMING AND BLOWDOWN

New boilers must be skimmed at the time of installation to remove threading oil and other impurities that float on the surface of the water.

1. Remove the plug from the skimmer tapping and pipe to a floor drain or bucket.
2. Raise the water level to the skimmer tapping.
3. Fire the boiler to maintain a water temperature of 180-200 degrees.
4. Feed water to the boiler to maintain the water level. Adjust the water feed rate to keep water continuously flowing out of the skimmer tapping without the water level going above or falling below the tapping. Cycle the burners to prevent boiling.
5. Continue skimming until the water runs clear. This may take several hours.
6. Float type low water cut offs must be blown down after skimming. The float chamber of the low water cut off must be flushed clean and maintained clear of sediment to allow free movement of the float. This must be done frequently during initial operation of the boiler, and at least once a week thereafter. Follow the instructions on the tag attached to the control.

Probe type low water cut offs require no maintenance at this time.

7. After blowing down the low water cut off and before blowing down the boiler, fill the boiler to the water line. Fire the burners and allow normal steam pressure to build up. Run a connection from the boiler blowdown valve to a nearby sewer or floor drain or to a safe discharge point outside. **Shut off the gas burners**, open the blowdown valve, and allow all of the water in the boiler to drain out.

Close the blowdown valve. Allow the boiler to cool thoroughly, and then slowly refill the boiler to the water line. Repeat this step as many times as necessary until the blowdown water is clear.

8. Following the final blow down, allow the boiler to thoroughly cool, and then add fresh water slowly up to the normal water line. Start the burners and maintain at least 180 degrees for 15 minutes to remove dissolved gasses from the fresh water. Shut off burners.

Now, let the boiler steam for a few days, to give the majority of the system dirt a chance to work its way back to the boiler. Then check the water in the gauge glass. The gauge glass should be dry above the water line. The water line should not bounce more than one inch when the boiler is steaming. If you see water droplets carrying over from the top of the gauge glass, or excessive bouncing of the water line, the boiler needs further cleaning. Take a water sample and boil it on the stove, to see if it foams. If it does, this also indicates the boiler needs to be cleaned.

If cleaning is necessary, repeat the skimming and blow down procedure from above. Usually, a long skim will be all you need to clean the boiler.

In more troublesome cases it may be desirable to flush the system as well. This is accomplished by closing the gate valve in the Hartford Loop, and opening the drain(s) at the end of the wet return(s). Run a hose from the drain valve on the wet return to a nearby floor drain or bucket. Run the boiler at two pounds of steam pressure. Feed just enough water to compensate for the waste condensate going down the drain, and to keep the boiler from going off on low water cut off. Run the boiler until all waste condensate runs clear.

### NOTE

Boiler cleaners and chemical cleaning additives are not recommended. If used and not rinsed properly, they will do more harm than good. The cleaning procedures laid out above will clean out the typical oils and impurities found in new boilers and in residential heating systems. The best thing for your boiler and heating system is clean water with no additives.

In very extreme cases it may be necessary to chemically clean and flush the heating system. Consult the boiler manufacturer before introducing any chemicals into the boiler.

# Maintaining Your Boiler

Check the water level every day or two. Verify the water line shown by operating the drain valve on the gauge. **BE SURE TOP AND BOTTOM VALVES ON GAUGE ARE ALWAYS OPEN SO THAT ACTUAL WATER LEVEL WILL BE SHOWN AT ALL TIMES.**

The gauge glass should be dry above the water line. The water line should not bounce more than about one inch when the boiler is steaming. If you see water droplets carrying over through the top of the gauge glass, or excessive bouncing of the water line, the boiler needs to be cleaned. Follow the instructions under "Cleaning Your Boiler."

## POP SAFETY VALVE

Before testing, make certain discharge pipe is properly connected to valve outlet and arranged to contain and safely dispose of boiler discharge. Under normal operating conditions a "try lever test" must be performed every month. A "try lever test" must also be performed at the end of any non-service period. Test at normal system operating pressure by holding the test lever fully open for at least five seconds to flush the valve seat free of sediment and debris. Then release lever and permit the valve to snap shut. If lift lever does not activate, or there is no evidence of discharge, turn off boiler immediately and contact a licensed contractor or qualified service personnel.

## LOW WATER CUT-OFF

The Low Water Cut-Off will interrupt the electrical current to the burner when the water line in the boiler drops to a low level.

On float type low water cut-offs, it is very important to keep the float chamber free from sediment, a condition essential to dependability. To keep any accumulation from interfering with float action is to "BLOW DOWN" or flush out the control regularly. This must be done two to three times during the first week after installation and once a week thereafter during the heating season. Do it while the boiler is in operation. First note water level in gauge glass. Open blow-off valve at bottom of control; water will pour out, flushing away sediment. Drain until water is clear, about a pailful, then close valve. If water level in gauge glass has dropped, add water to boiler to restore level. Consult low water cut-off manufacturer's instructions included with boiler.

**NOTE:** Opening blow-off valve checks cut-off operation too. As float drops with falling water level, burners will shut off. After valve is closed and normal operating conditions are restored, burners will resume firing.

For probe type Low Water Cut-Offs, check action of the Low Water Cut-Off monthly to make sure it is providing the proper protection. See "Checking and Adjusting" on page 19. Low Water Cut-Off remote probes must be removed for periodic inspection and cleaning, preferably at the beginning of each heating season. More frequent cleaning may be required on boilers requiring constant or very frequent additions of make up water.

## BURNERS

A visual check of the pilot and main burner flames should be made at least once each year, preferably at the beginning of the heating season. See page 19.

## BOILER FLUE PASSAGES

Under normal operating conditions, with the burners properly adjusted, it should not be necessary to clean the boiler flue gas passages. However, to assure trouble-free operation, we recommend that you have the flue passages, burner adjustment, and operation of the controls checked *once each year* by a competent Service Technician.

*Before the start of each season* (or whenever system has been shut down for some time) recheck the whole system for leaks . . . and recheck the boiler and vent pipe for leaks.

## VENT PIPE

The venting of this unit is very important and the piping should be checked at least once a season. If the vent piping shows any sign of leaking, replace it immediately.

## CLEANING YOUR BOILER FLUE PASSAGES AND BURNERS

Flue Passages between sections should be examined yearly and cleaned, if necessary. To clean, remove burners, pilot, and vent pipe. Remove top and front jacket panels. Remove the two screws attaching the intermediate front panel to the left and right side jacket panels. Remove the draft diverter and intermediate front panel as a unit. Carefully remove the cerafelt gasket strips. Clean passageways between sections with a flexible handle wire brush. Remove dirt from bottom of boiler and from between sections by vacuuming. Make sure all flame ports in burners are open and clear. Shake out or blow out all loose dirt in burners. Reseal seams between adjacent sections as necessary with 400F RTV silicone sealant. Reassemble all parts. Be sure to check tightness of pilot connections and condition of burner flames after reassembly (see Figures 18 and 19). Be sure vent pipe connections to chimney are secure and no obstructions are present.

## FOAMING, PRIMING OR SURGING

These terms are used to describe a fluctuating water line – when water leaves the boiler with the steam.

It is caused by any combination of the following:

1. Threading oil and organic matter in the boiler water. (Mineral oil, or core sand does not cause surging.) Follow instructions under "Cleaning Your Boiler."
2. Faulty quick vents that do not release air until a sizeable pressure is built up – if old style, replace – if dirty, clean so you can easily blow through valve.
3. Improper header design – when steam flows in opposite direction of equalizer line on "Hartford Loop." Generally a 15" horizontal run between riser and main takeoff will allow entrained water to fall out of the steam vapor so it can return to boiler. (See Figures 5, 6A & 6B on pages 5 and 6).
4. Adjustment of steam limit control to a wide differential increases difficulty if quick vents are old style, slow-releasing type or dirty. Always set steam limit control differential as low as possible.
5. Soap and detergents in the boiler water cause extreme surging. Boiler cleaners and chemical cleaning additives are not recommended. If used and not rinsed properly, they will do more harm than good. The cleaning procedures laid out in these instructions will clean out the typical oils and impurities found in new boilers and in residential heating systems. The best thing for your boiler and heating system is clean water with no additives.

### CAUTION

Never refill a hot boiler with cold water – the danger of thermal shock may crack a section.

## BOILER WATER TREATMENT (Other Than Cleaners)

In steam systems where the system is tight, free from leaks, and all the steam is returned to the boiler as condensate, the amount of make up water is small. Water treatment is generally not required.

In steam systems with less than 90% of the steam being returned as condensate, or with very hard or corrosive make up water, treatment may be desirable. Follow the recommendations of your local boiler water treatment specialist.

## BETWEEN HEATING SEASONS

Boilers should not be drained between heating seasons. Steam boilers should be entirely filled with water during the summer months to exclude air.

# Service Hints

You may avoid inconvenience and service calls by checking these points before you call for service.

## FOR YOUR SAFETY WHAT TO DO IF YOU SMELL GAS

1. Do Not try to light any appliance.
2. Do not touch any electric switch, do not use the phone.
3. Leave the building immediately, then call your gas supplier.
4. If you cannot reach the gas supplier, call the fire department.

### IF YOUR SYSTEM IS NOT HEATING OR NOT GIVING ENOUGH HEAT . . .

Possible Cause	What to do
Thermostat is not set correctly Burner is not operating properly	Reset thermostat above room temperature. Check flame. If it is yellow, the burner is not getting enough air. Or, if flame is blue and noisy and seems to lift off the burner, the burner is getting too much air. Contact your service technician.
No electric power to boiler	Check overcurrent protection. Check to be sure electric power supply circuit is "ON."
Controls out of adjustment Radiators not heating	Reset according to instructions. Steam air vents are not operating properly. Check flow control valve (if used). It may be in closed position.
Poor electrical contact Rollout switch blown	Check all control terminals and wire joints. Have your service technician check heat exchanger for blockage. Replace rollout switch with exact replacement.
Chimney flue is blocked	Spill switch contacts open, requiring manual reset of spill switch. Have your service technician check and correct chimney problem.
Vent damper not operating	Consult troubleshooting guide in Effikal manual, packaged with vent damper.

### IF BURNER IS NOISY . . .

Possible Cause	What to do
Gas input amount is incorrect	Contact your service technician.

### IF WALLS OR WINDOWS SWEAT . . .

Possible Cause	What to do
Not enough ventilation Chimney flue is blocked	Contact your service technician. Have your service technician check and correct, if necessary.

### IF RADIATORS ARE NOISY . . .

Possible Cause	What to do
Air in system	Refer to "Radiators Not Heating Properly" above

### POP SAFETY VALVE LEAKING . . .

Possible Cause	What to do
Dirt on seat	Open valve manually. Allow steam to blow and clear valve seat.

**HAVE YOUR SERVICE TECHNICIAN CHECK ANY PROBLEM YOU ARE UNABLE TO CORRECT.**



# Repair Parts

## GAS – FIRED HOT WATER BOILERS

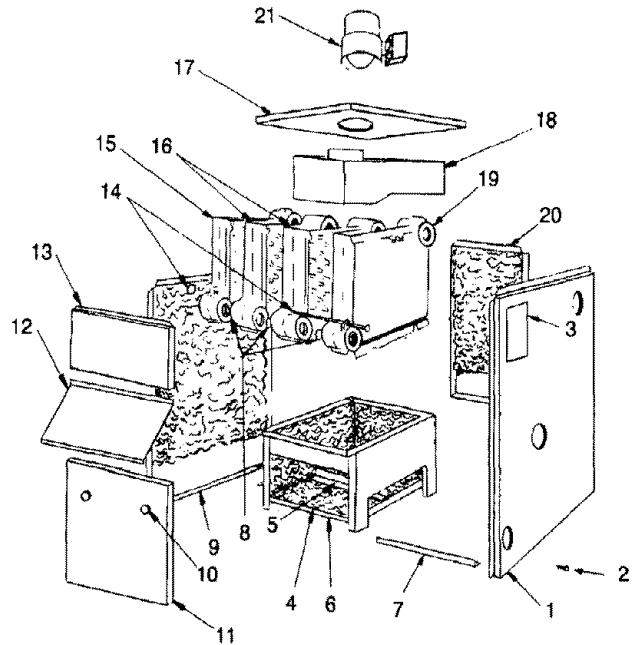
– IMPORTANT –

### READ THESE INSTRUCTIONS BEFORE ORDERING

All parts are listed in the following Parts List may be ordered through your nearest supplier.

When ordering parts, first obtain the Model Number from the data plate on your boiler, than determine the Part No. (not the Key No.) and the Description of each part from the following illustrations and list. Be sure to give us all this information:

The Part No. – The Part Description – The Boiler Model No.



## JACKET - SECTION AND BASE PARTS

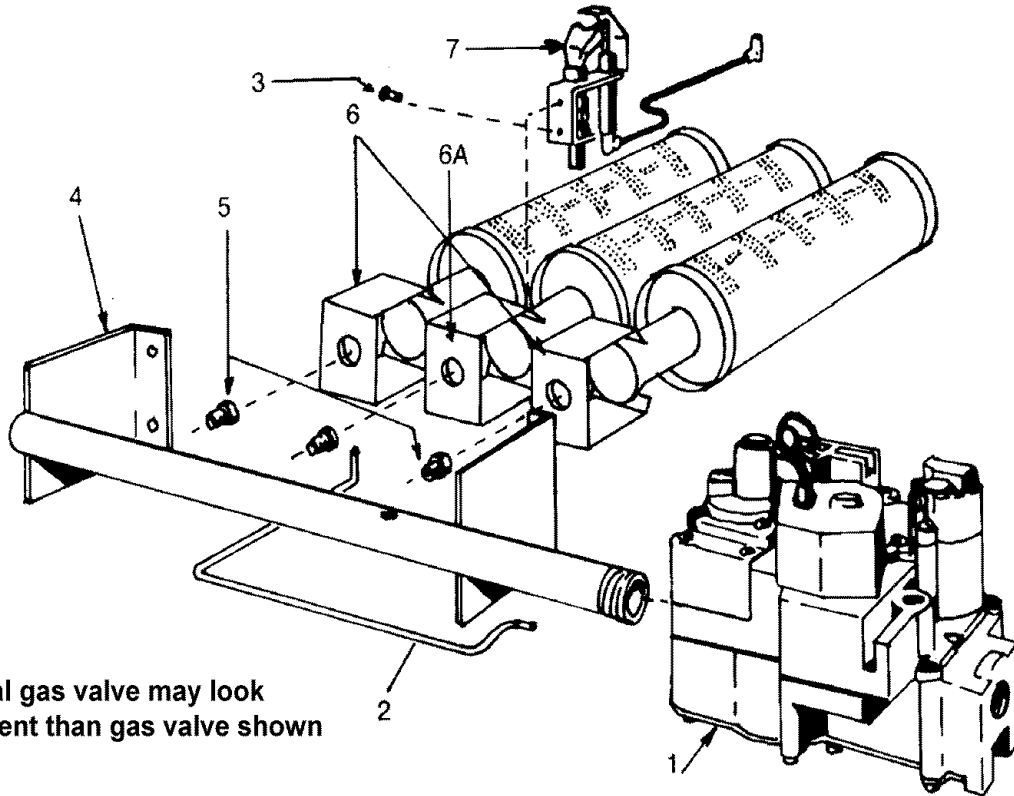
THIS IS A REPAIR PARTS LIST - NOT A PACKAGING LIST

KEY NO.	DESCRIPTION	3 SECTION	4 SECTION	5 SECTION	6 SECTION	7 SECTION	8 SECTION	9 SECTION
		Part No.	Part No.	Part No.	Part No.	Part No.	Part No.	Part No.
1	Jacket, Right Side Panel	425-00-802	425-00-802	425-00-802	425-00-802	425-00-802	425-00-802	425-00-802
2	#10 x 1/2 Sheet Metal Screw	146-95-074	146-95-074	146-95-074	146-95-074	146-95-074	146-95-074	146-95-074
3	Rating Plate	146-80-901	146-80-901	146-80-901	146-80-901	146-80-901	146-80-901	146-80-901
4	Base Insulation - Base Sides (2)	146-14-130	146-14-130	146-14-130	146-14-130	146-14-130	146-14-130	146-14-130
	- Base Front	146-14-113	146-14-114	146-14-115	146-14-116	146-14-117	146-14-118	146-14-119
	- Base Rear	146-14-123	146-14-124	146-14-125	146-14-126	146-14-127	146-14-128	146-14-129
5	Base Baffle	425-00-643	425-00-644	425-00-645	425-00-646	425-00-647	425-00-648	425-00-649
6	Base	425-00-663	425-00-664	425-00-665	425-00-666	425-00-667	425-00-668	425-00-669
7	Jacket Tie Bar	425-00-653	425-00-654	425-00-655	425-00-656	425-00-657	425-00-658	425-00-659
8	Push Nipple	433-00-976	433-00-976	433-00-976	433-00-976	433-00-976	433-00-976	433-00-976
9	Jacket, Left Side Panel	425-00-801	425-00-801	425-00-801	425-00-801	425-00-801	425-00-801	425-00-801
10	Knob, Service Door (Pair)	137-02-153	137-02-153	137-02-153	137-02-153	137-02-153	137-02-153	137-02-153
11	Jacket, Service Door	425-00-823	425-00-824	425-00-825	425-00-826	425-00-827	425-00-828	425-00-829
12	Jacket, Int'd. Panel	425-00-813	425-00-814	425-00-815	425-00-816	425-00-817	425-00-818	425-00-819
13	Jacket, Front Panel	425-00-811	425-00-804	425-00-805	425-00-806	425-00-807	425-00-808	425-00-809
14	1/4" Tie Rod, Nut	146-05-001	146-05-002	146-05-051	146-05-053	146-05-005	146-05-007	146-05-009
15	Boiler Section, Left	410-00-013	410-00-013	410-00-013	410-00-013	410-00-013	410-00-013	410-00-013
16	Boiler Section, Middle	410-00-015	410-00-015	410-00-015	410-00-015	410-00-015	410-00-015	410-00-015
17	Jacket, Top Panel	425-00-843	425-00-844	425-00-845	425-00-846	425-00-847	425-00-848	425-00-849
18	Draft Diverter	425-00-673	425-00-674	425-00-675	425-00-676	425-00-677	425-00-678	425-00-679
19	Boiler Section, Right	410-00-014	410-00-014	410-00-014	410-00-014	410-00-014	410-00-014	410-00-014
20	Jacket, Back Panel	425-00-833	425-00-834	425-00-835	425-00-836	425-00-837	425-00-838	633-00-1029
‡	Jacket Complete	425-00-873	425-00-874	425-00-875	425-00-876	425-00-877	425-00-878	425-00-879
‡	Block Assembly (19, 16, 15, 14, 8)	410-00-330	410-00-430	410-00-530	410-00-630	410-00-730	410-00-830	410-00-930
‡	Combustible Floor Plate	146-14-031	146-14-031	146-14-031	146-14-031	146-14-032	146-14-032	146-14-032
‡	Cerafelt Gasket	146-14-018	146-14-018	146-14-018	146-14-018	146-14-018	146-14-018	146-14-018
21	Vent Damper	118-20-05	118-20-06	118-20-06	118-20-06	118-20-07	118-20-07	118-20-07
‡	Base Assembly (6, 5, 4)	433-00-663	433-00-664	433-00-665	433-00-666	433-00-667	433-00-668	433-00-669
‡	Rollout Switch Bracket (Nat. Gas Only)	425-00-604	425-00-605	425-00-606	425-00-607	425-00-608	425-00-609	425-00-610

‡ Not illustrated

# Repair Parts

FOR USE WITH NATURAL GAS ONLY



NOTE: Actual gas valve may look different than gas valve shown

## NATURAL GAS BURNERS AND MANIFOLD PARTS

THIS IS A REPAIR PARTS LIST - NOT A PACKING LIST

### ELECTRONIC INTERMITTENT IGNITION (Shown)

KEY NO.	DESCRIPTION	3 SECTION	4 SECTION	5 SECTION	6 SECTION	7 SECTION	8 SECTION	9 SECTION
		Part No.	Part No.	Part No.	Part No.	Part No.	Part No.	Part No.
1	24 Volt Gas Valve, Elect. Inter. Ignition	146-62-052	146-62-052	146-62-052	146-62-058	146-62-058	146-62-058	146-62-058
2	Pilot Tube	146-15-005	146-15-005	146-15-005	146-15-005	146-15-005	146-15-005	146-15-005
3	10-32 3/16 Hex Hd. Screw	146-95-301	146-95-301	146-95-301	146-95-301	146-95-301	146-95-301	146-95-301
4	Gas Manifold	146-16-033	146-16-034	146-16-035	146-16-013	146-16-014	146-16-015	146-16-016
5	Main Burner Orifice*	146-15-031	146-15-031	146-15-031	146-15-035	146-15-035	146-15-035	146-15-035
6	Main Burner, Regular**	146-15-532	146-15-532	146-15-532	146-15-532	146-15-532	146-15-532	146-15-532
6A	Main Burner, Pilot Mount	146-15-531	146-15-531	146-15-531	146-15-531	146-15-531	146-15-531	146-15-531
7	Pilot Burner	146-62-092	146-62-092	146-62-092	146-62-092	146-62-092	146-62-092	146-62-092
‡	Rollout Shield	425-00-933	425-00-934	425-00-935	425-00-936	425-00-937	425-00-938	425-00-939

### ALTERNATE PARTS FOR CONTINUOUS PILOT - 24 VOLT

1	24 Volt Gas Valve, Continuous Pilot	146-62-051	146-62-051	146-62-051	146-62-060	146-62-060	146-62-060	146-62-060
3	10-32 3/16 Hex Hd. Screw (2 req'd)	146-95-301	146-95-301	146-95-301	146-95-301	146-95-301	146-95-301	146-95-301
7	Pilot Burner	146-62-098	146-62-098	146-62-098	146-62-098	146-62-098	146-62-098	146-62-098
‡	Thermocouple	152-00-01	146-62-039	146-62-039	146-62-039	146-62-039	146-62-039	146-62-039

Quantity is 1 unless otherwise noted.

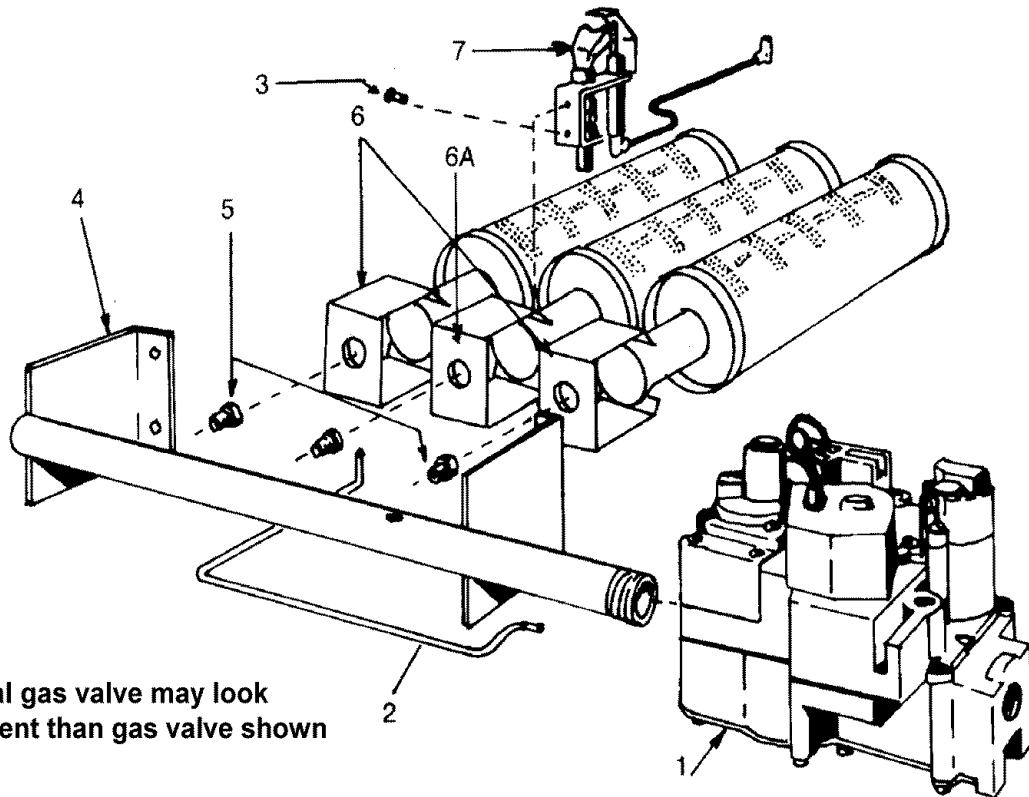
\* Requires 1 less than the number of sections.

\*\* Requires 2 less than the number of sections

‡ Not Illustrated

# Repair Parts

FOR USE WITH PROPANE GAS ONLY



NOTE: Actual gas valve may look different than gas valve shown

## PROPANE GAS BURNERS AND MANIFOLD PARTS

THIS IS A REPAIR PARTS LIST - NOT A PACKING LIST

### ELECTRONIC INTERMITTENT IGNITION (Shown)

KEY NO.	DESCRIPTION	3 SECTION	4 SECTION	5 SECTION	6 SECTION	7 SECTION	8 SECTION	9 SECTION
		Part No.	Part No.	Part No.	Part No.	Part No.	Part No.	Part No.
1	24 Volt Gas Valve, Elect. Inter. Ignition	146-62-062	146-62-062	146-62-062	146-62-062	146-62-062	146-62-062	146-62-062
2	Pilot Tube	146-15-005	146-15-005	146-15-005	146-15-005	146-15-005	146-15-005	146-15-005
3	10-32 3/16 Hex Hd. Screw	146-95-301	146-95-301	146-95-301	146-95-301	146-95-301	146-95-301	146-95-301
4	Gas Manifold	146-16-010	146-16-011	146-16-012	146-16-013	146-16-014	146-16-015	146-16-016
5	Main Burner Orifice*	146-15-036	146-15-036	146-15-036	146-15-036	146-15-036	146-15-036	146-15-036
6	Main Burner, Regular**	146-15-532	146-15-532	146-15-532	146-15-532	146-15-532	146-15-532	146-15-532
6A	Main Burner, Pilot Mount	146-15-531	146-15-531	146-15-531	146-15-531	146-15-531	146-15-531	146-15-531
7	Pilot Burner	146-62-094	146-62-094	146-62-094	146-62-094	146-62-094	146-62-094	146-62-094
‡	Rollout Shield	425-00-933	425-00-934	425-00-935	425-00-936	425-00-937	425-00-938	425-00-939

### ALTERNATE PARTS FOR CONTINUOUS PILOT - 24 VOLT

1	24 Volt Gas Valve, Continuous Pilot	146-62-061	146-62-061	146-62-061	146-62-061	146-62-061	146-62-061	146-62-061
3	10-32 3/16 Hex Hd. Screw (2 req'd)	146-95-301	146-95-301	146-95-301	146-95-301	146-95-301	146-95-301	146-95-301
7	Pilot Burner	146-62-098	146-62-098	146-62-098	146-62-098	146-62-098	146-62-098	146-62-098
‡	Thermocouple	152-00-01	146-62-039	146-62-039	146-62-039	146-62-039	146-62-036	146-62-036

Quantity is 1 unless otherwise noted.

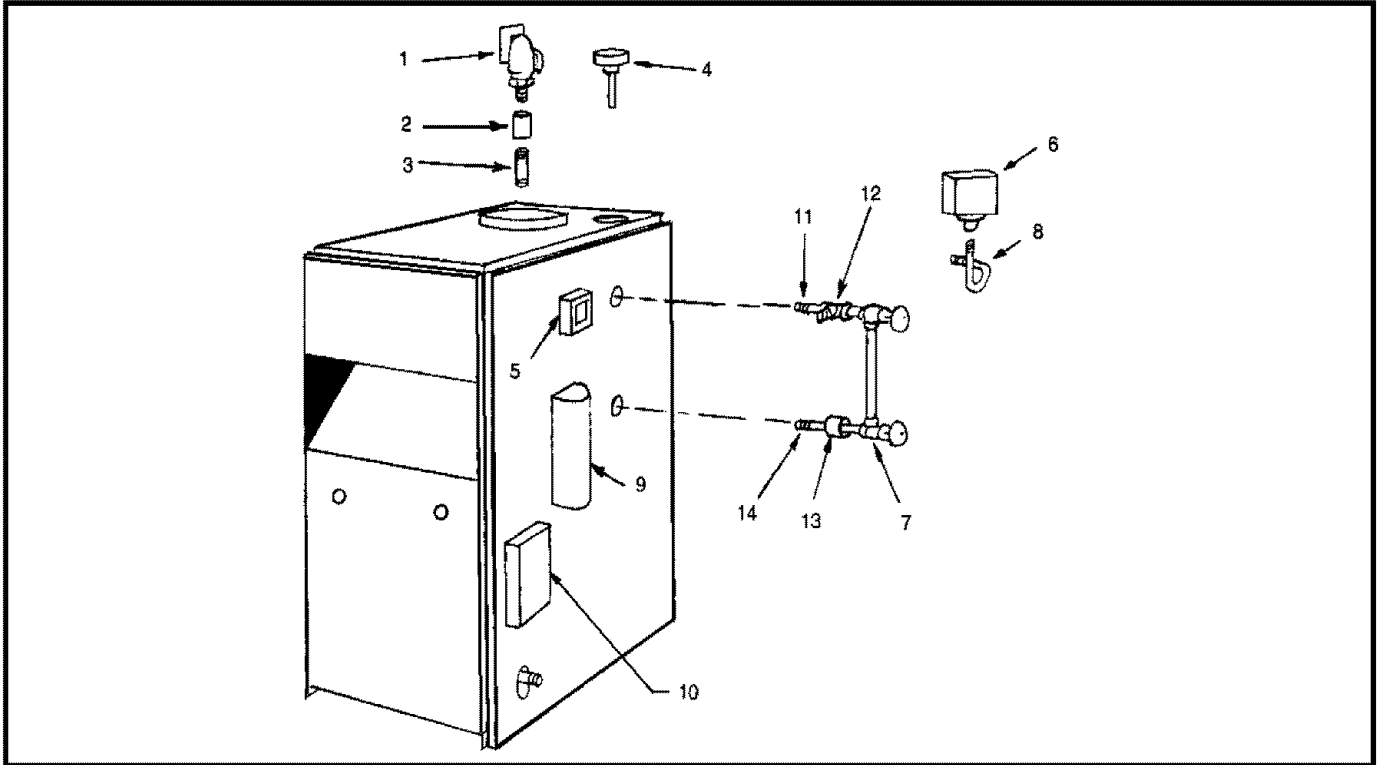
\* Requires 1 less than the number of sections.

\*\* Requires 2 less than the number of sections

‡ Not Illustrated

# Repair Parts

## BOILER CONTROLS AND PIPING



Key No.	Description	Part No.
1	3/4" Pop Safety Valve	157-00-01
2	3/4" Coupling	115-00-01
3	3/4" x 6 1/2" Nipple	146-07-002
4	Steam Pressure Gauge	146-23-005
5	AT-150D Transformer	146-62-305
6	PA-404A Pressretrol	146-62-015
7	Glass Water Gauge Set (used with PS-802 LWCO)	146-22-005
‡	Glass Water Gauge Set (used with 67D-1 LWCO)	146-22-010
8	90° Pigtail (used with PS-802 LWCO)	146-43-004
‡	180° Pigtail (used with 67D-1 LWCO)	146-43-005
9	PS-802 Low Water Cut-Off	128-00-02
‡	67D-1 Low Water Cut Off	146-26-042
10	Intermittent Pilot Control	146-62-070
11	1/2" x 3" Brass Nipple (PS-802 only)	131-00-03
12	1/2" x 1/2" x 1/4" Brass Tee (PS-802 only)	146-93-051
13	1/2" Brass Coupling (PS-802 only)	146-93-052
14	1/2" x 3 1/2" Brass Nipple (PS-802 only)	146-07-024
‡	3/4" Drain Valve	146-22-001
‡	WF-2U-24 Water Feeder (Optional)	163-00-01
‡	Rollout Switch	146-29-002
‡	Spill Switch (36TX16-6282) 280°F	146-60-002
‡	5" Vent Damper (3 Section Boilers)	118-20-05
‡	6" Vent Damper (4, 5 Section Boilers)	118-20-06
‡	7" Vent Damper (6, 7, 8, 9 Section Boilers)	118-20-07
‡	Vent Damper Operator (Motor)	114-00-02
‡	400°F Black Silicone Rubber Adhesive Sealent (10.3 oz. Cartridge)	146-06-020

‡ Not Illustrated