

INSTALLATION INSTRUCTIONS

Fan Coils

AHX3

These instructions must be read and understood completely before attempting installation.

Safety Labeling and Signal Words

DANGER, WARNING, CAUTION, and NOTE

The signal words **DANGER**, **WARNING**, **CAUTION**, and **NOTE** are used to identify levels of hazard seriousness. The signal word **DANGER** is only used on product labels to signify an immediate hazard. The signal words **WARNING**, **CAUTION**, and **NOTE** will be used on product labels and throughout this manual and other manuals that may apply to the product.

DANGER - Immediate hazards which **will** result in severe personal injury or death.

WARNING - Hazards or unsafe practices which **could** result in severe personal injury or death.

CAUTION - Hazards or unsafe practices which **may** result in minor personal injury or product or property damage.

NOTE - Used to highlight suggestions which **will** result in enhanced installation, reliability, or operation.

Signal Words in Manuals

The signal word **WARNING** is used throughout this manual in the following manner:



The signal word **CAUTION** is used throughout this manual in the following manner:



Signal Words on Product Labeling

Signal words are used in combination with colors and/or pictures on product labels.

TABLE OF CONTENTS

Introduction	2
Location	2
Position Unit	4
Air Ducts	5
Electrical Connections	5
Refrigerant Tubing	6
Refrigerant Metering Device	6
Condensate Drains	6
Schematic	8
Sequence of Operation	10
Care and Maintenance	10
Parts	11

DEATH, PERSONAL INJURY, AND/OR PROPERTY DAMAGE HAZARD

Failure to carefully read and follow this warning could result in equipment malfunction, property damage, personal injury and/or death.

Installation or repairs made by unqualified persons could result in equipment malfunction, property damage, personal injury and/or death.

The information contained in this manual is intended for use by a qualified service technician familiar with safety procedures and equipped with the proper tools and test instruments.

Installation must conform with local building codes and with the National Electrical Code NFPA70 current edition.

Figure 1 Clearances and Unit Dimensions

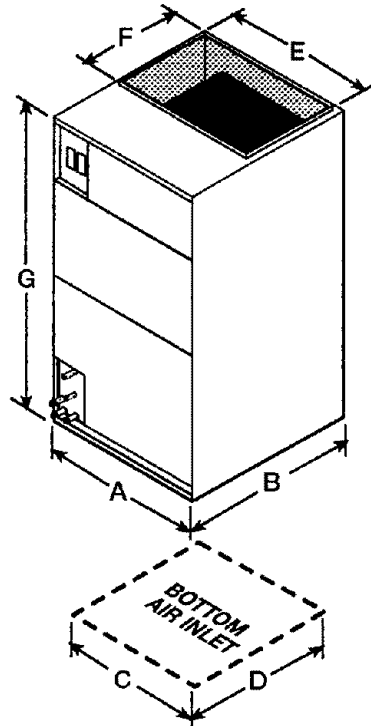

REQUIRED CLEARANCES (inches)		
All Models	All Sides	0
	Serviceability from the front	30
	From Supply Duct	0

DIMENSIONAL DATA												
Model	Size (tons)	all dimensions inches									Coil Type	Ship. Weight (lbs)
		A	B	C	D	E	F	G	Liquid	Suct.		
AHX32400	2	17 ¹ / ₂	21	15	17 ¹ / ₂	16	12 ⁵ / ₈	40 ³ / ₄	³ / ₈	³ / ₄	"A"	144
AHX33600	3	17 ¹ / ₂	21	15	17 ¹ / ₂	16	12 ⁵ / ₈	40 ³ / ₄	³ / ₈	³ / ₄	"A"	144
AHX34800	4	21 ¹ / ₂	25	19 ¹ / ₄	22 ¹ / ₄	19 ⁵ / ₈	17 ¹ / ₄	49 ³ / ₄	³ / ₈	⁷ / ₈	"A"	192
AHX36000	5	21 ¹ / ₂	25	19 ¹ / ₄	22 ¹ / ₄	19 ⁵ / ₈	17 ¹ / ₄	49 ³ / ₄	³ / ₈	⁷ / ₈	"A"	192

INTRODUCTION

Models AHX3 are designed for an upflow vertical applications.

All models are available for system sizes 2 - 5 tons (24,000 - 60,000 BTUH) nominal cooling capacity.

All models have a factory installed 15% bleed port TXV designed for use with R-22 refrigerant. AHX3 are for

R-22 refrigerant ONLY. Use only with outdoor units designed for R-22

An accessory R410A TXV kit is available through the distributor. AHTXV153 (2 - 3 ton) or AHTXV355 (4 - 5 ton)

LOCATION

Select the best position which suits the installation site conditions. The location should provide adequate structural support, space in the front of the unit for service access, clearance for return air and supply duct connections, space for refrigerant piping connections and

condensate drain line connections. **See Clearances in Figure 1.**

If the unit is located in an area of high humidity, nuisance sweating of casing may occur. On these installations a

wrap of 2" fiberglass insulation with a vapor barrier is recommended.

NOTE: Internal filter can be accessed from separate filter door. If the filter can **NOT** be easily accessed, a remote filter is recommended. Refer to ACCA Manual D for remote filter sizing.

⚠ WARNING

FIRE HAZARD

Failure to maintain proper clearances could result in personal injury, death, and/or property damage.

When heaters are installed, maintain clearances from combustible materials as specified on unit rating plate. Do not use plastic lined or combustible flexible ducting within 36 inches of the supply end of the fan coil.

Figure 2	Blower Data												
Model No	Airflow Tonnage Range	Motor @ 230V 1 Ph 60 Hz		DD Blower Wheel	3-Spd Motor	Duty	SCFM vs. ESP (1) (2)						
		HP	FLA				.1	.2	.3	.4	.5		
AHX32400	1.5-2.0	1/4	1.7	10x6			H	Cool	950	900	850	790	720
							M	Cool	950	900	850	790	720
							L	Heat	950	900	850	790	720
AHX33600	2.5-3.0	1/3	2.8	10x7			H	Cool	1250	1200	1120	1060	1000
							M	Cool	1070	1020	970	920	860
							L	Heat	900	870	840	790	720
AHX34800	3.0-4.0	1/3	3.1	10x8			H	Cool	1850	1700	1650	1500	1410
							M	Cool	1750	1650	1450	1330	1180
							L	Heat	1150	1060	1000	920	810
AHX36000	4.0-5.0	3/4	4.8	11x9			H	Cool	2160	2100	2000	1940	1880
							M	Cool	2110	1980	1810	1750	1650
							L	Heat	2000	1860	1670	1340	1200

Notes: (1) Based upon unit with nominal tannage dry coil and filter installed.
 (2) Use .96 as approximate SCFM correction factor for wet coil.

Figure 3		Electric Heat Performance Data							
Fan Coil Model AHX3	Heater Model No.	Nominal SCFM	Nominal Cooling BTUH	KW Electric		Min. Circuit		240V	208V
				240V	208V	240V	208V		
2400	None	800	18,000	0	0	2.2	1.9	15	15
	HTR05BS1	to	to	5	3.8	30	27	30	30
	HTR10BS1	900	24,000	10	7.5	56	49	60	50
3600	None	1020	30,000	0	0	3.1	3.0	15	15
	HTR05BS1			5	3.8	30	27	30	30
	HTR10BS1			10	7.5	56	49	60	60
	HTR15BS1			15	11.3	56/26	49/23	60/30	50/30
4800	None	1250	42,000	0	0	3.1	3.0	15	15
	HTR05BL1			5	3.8	30	27	30	30
	HTR10BL1			10	7.5	59	52	60	60
	HTR15BL1			15	11.3	53/27	46/24	60/30	50/30
	HTR20BL1			20	15	59/53	52/46	60/60	60/50
6000	None	1980	48,000	0	0	6.0	5.9	15	15
	HTR10BL1			10	7.5	59	52	60	60
	HTR15BL1			15	11.3	56/27	49/24	60/30	50/30
	HTR20BL1			20	15	59/53	52/46	60/60	60/50
				2100	60,000				

POSITION UNIT

Unit is designed to be installed in a closet or flush mounted. Can be serviced entirely from the front, including replacing the filter. Allow space for wiring, piping, and servicing unit.



CAUTION

PROPERTY DAMAGE HAZARD

Failure to follow this caution may result in property damage

A field fabricated auxiliary drain pan, with a separate drain is REQUIRED for all installations over a finished living space or in any area that may be damaged by overflow from a restricted main drain pan. In some localities, local codes require an auxiliary drain pan for ANY horizontal installation.

A. UPFLOW INSTALLATION

If return air is to be ducted through a floor, set unit on floor over opening and use 1/8 to 1/4 inch thick fireproof resilient gasket between duct, unit, and floor.

Exterior surface may sweat when unit is installed in non-conditioned space. Installer must provide protection such as full size auxiliary drain pan on all units installed in non-

AIR DUCTS

Connect supply-air duct over the outside of 3/4" flanges provided on supply-air opening. Secure duct to flange using proper fasteners for type of duct used, and seal duct-to-unit joint. If return-air flanges are required, install factory authorized accessory kit.

Use flexible connectors between duct work and unit to prevent transmission of vibration. Duct work passing through unconditioned space must be insulated and covered with vapor barrier to prevent formation of condensate to prevent formation of condensate.

ELECTRICAL CONNECTIONS

Refer to the unit's nameplate for specific electrical data. Before proceeding with electrical connections, make certain that supply voltage, frequency, phase, and circuit ampacity are as specified on the unit rating plate. Make all electrical connections in accordance with the NEC and any local codes or ordinances that may apply. Use copper wire rated for 75 degrees C minimum wire in the unit wiring compartment only. A single power supply may be connected directly to terminal block provided in the unit.

conditioned space to prevent damage from condensation runoff. It is recommended that units be insulated with 1" thick fiberglass with the vapor barrier on the outside.

B. HORIZONTAL APPLICATION

Units are shipped in right to left configuration. Horizontal applications require a return air duct be attached to the furnace inlet. The opposite end of the return air duct is attached to a return air filter grill through the ceiling or wall.

For left to right applications:

1. Remove and set aside front panels.
2. Remove the coil support bracket (4 screws).
3. Remove horizontal drain pan retaining clip (1 screw).
4. Carefully remove coil assembly and bottom drain pan.
5. Move Horizontal drain pan from left hand side of coil to right.
6. Install modified coil assembly back into unit.
7. Reinstall coil support bracket and horizontal drain pan retaining clip.
8. Determine drain holes being used and reposition knockout caps.
9. Reinstall doors.

Duct work Acoustical Treatment

Metal duct systems that do not have a 90 degree elbow and 10 feet of main duct before first branch takeoff may require internal acoustical insulation lining. As an alternative, fibrous duct work may be used if constructed and installed in accordance with the latest edition of SMACNA construction standard on fibrous glass ducts. Both acoustical lining and fibrous duct work shall comply with National Fire Protection Association as tested by UL Standard 181 for Class 1 air ducts.



WARNING

ELECTRICAL SHOCK or UNIT DAMAGE HAZARD

Failure to follow this warning could result in personal injury, death, and/or unit damage.

If a disconnect switch is to be mounted on unit, select a location where drill and fasteners will not contact electrical or refrigeration components.

⚠ WARNING

ELECTRICAL SHOCK HAZARD
 Failure to follow this warning could result in personal injury or death.

Turn off the main (remote) disconnect device before working on incoming (field) wiring . Incoming (field) wires on the line side of the disconnect found in the fan coil unit remain live, even when the pull-out is removed. Service and maintenance to incoming (field) wiring cannot be performed until the main disconnect switch (remote to the unit) is turned off.

A. LINE VOLTAGE CONNECTIONS

This Fan Coil is not electric heat compatible.

1. Connect 208/240V power leads from field disconnect to units high voltage terminal block.
2. Connect ground wire to unit ground lug.

B. 24V CONTROL SYSTEM

Connection to Unit

Wire low voltage in accordance with wiring label on the unit. Use 18 AWG color-coded, insulated (35 degrees C minimum) wire to make the low-voltage connections between the thermostat, the unit, and the outdoor equipment. If the thermostat is located more than 100 feet from the unit (as measured along the low voltage wire), use 16 AWG color-coded, insulated (35 degrees C minimum) wire. All wiring must be NEC Class 2 and must be separated from incoming power leads. Refer to outdoor unit wiring instructions for additional wiring recommendations.

NOTE: Before proceeding with electrical connections, make certain that supply voltage, frequency, phase, and circuit ampacity are as specified on the unit rating plate. See unit wiring label for proper field high and low voltage wiring. Make all electrical connections in accordance with the NEC and any local codes or ordinances that may apply. Use copper wire only. The unit must have a separate branch electric circuit with a field-supplied disconnect switch located within sight from, and readily accessible from the unit.

Transformer Information

Transformer is factory wired for 208/240V operation.

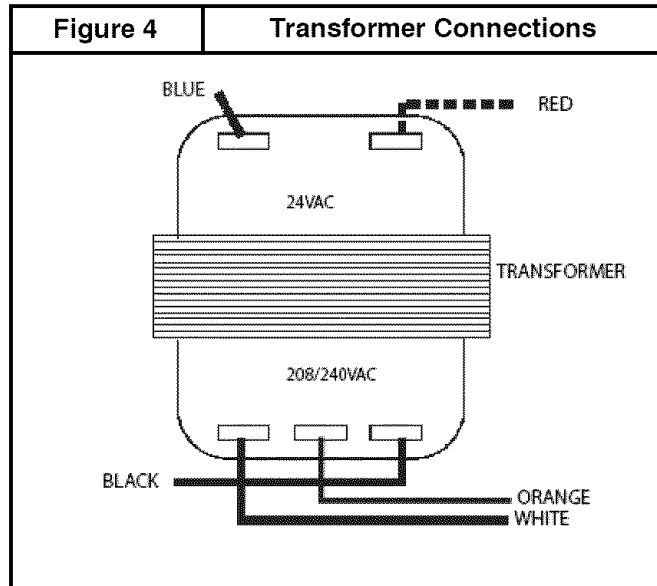

C. GROUND CONNECTIONS

⚠ WARNING

ELECTRICAL SHOCK HAZARD
 Failure to establish uninterrupted or unbroken ground could result in personal injury and/or death.

According to NEC, ANSI/NFPA 70, and local codes, the cabinet must have an uninterrupted or unbroken ground in order to minimize potential for personal injury or death if an electrical fault should occur. The ground may consist of electrical wire or metal conduit when installed in accordance with existing electrical codes. If conduit connection uses reducing washers, a separate ground wire must be used.

NOTE: Use UL listed conduit and conduit connectors for connecting supply wire(s) to unit to obtain proper grounding. Grounding may also be accomplished by using grounding lugs provided in control box.

D. MINIMUM CFM AND MOTOR SPEED SELECTION

Units require a minimum CFM. Refer to the unit wiring label to ensure that the fan speed selected is not lower than the minimum fan speed indicated.

Fan speed selection is done at the fan relay. To change motor speeds, disconnect fan lead used on relay terminal (FR) and replace with motor speed lead desired (refer to Figure 8). Save insulating cap and place on motor lead removed from relay.

NOTE: In low static applications, lower motor speed tap should be used to reduce possibility of water being blown off coil.

All units have three (3) motor speed taps. Low speed (red or 4) is designed for mismatch outdoor unit applications.

Medium speed (blue or 3) is designed for straight matched operations. High speed (black or 2) is used with high external static duct situations on straight matched systems.

REFRIGERANT TUBING

Size and install refrigerant lines according to information provided with outdoor unit. Route refrigerant lines to the fan coil in a manner that will not obstruct service access to the unit or removal of the filter.

1. Find the liquid tube grommet in the small-parts bag and slide it onto the liquid refrigerant line (field line-set).
2. Remove the lower door. Remove the tubing plate (with suction tube grommet) and slide the plate with grommet onto the refrigerant lines (field line-set), away from braze joints.
3. Using a tubing cutter, carefully cut approximately 1/2" off of the suction and liquid line stubs. **These coils are pressurized with a nitrogen holding charge.** Cut the first stub, either the suction or liquid line slowly to allow the pressure to escape before cutting all the way through the entire stub.

4. Wrap TXV and nearby tubing with a heat-sinking material such as a wet cloth.
5. Fit refrigerant lines into coil stubs. Wrap a heat-sinking material such as a wet cloth behind braze joints.
6. Braze using a Sil-Fos or Phos-copper alloy.
7. After brazing, allow joints to cool. Slide tubing plate back into place and position grommets around suction and liquid tubes to ensure air seal.

 **CAUTION**

PRODUCT DAMAGE HAZARD

Failure to follow this caution may result in product damage.

Braze with Sil-Fos or Phos-copper alloy on copper-to-copper joints and wrap a wet cloth around rear of fitting to prevent damage to TXV.

REFRIGERANT METERING DEVICE

These Fan Coils have a factory installed 15% bleed port TXV designed for use with R-22 refrigerant. Use only with outdoor units designed for R-22.

TXV is factory set and not field adjustable.

 **CAUTION**

PRODUCT DAMAGE HAZARD

Failure to follow this caution may result in product damage.

This Fan Coil has a hard shut-off TXV metering device. A compressor Hard Start Kit is REQUIRED in all applications where the matching outdoor unit has a single-phase reciprocating compressor.

CONDENSATE DRAINS

Unit is provided with primary and secondary 3/4" NPT drain connections. Refer to Figure 7 to identify the primary and secondary locations. To prevent property damage and achieve optimum drainage performance, BOTH primary and secondary drain lines should be installed and include properly sized condensate traps. Factory approved condensate traps are available (accessory part number EBAC01CTK).

Install traps in the condensate lines as close to the coil as possible (refer to Figure 7), but avoid blocking filter access panel.

Install drain lines below the bottom of the drain pan and pitch the drain lines down from the coil at least 1/4 inch per foot of run. Horizontal runs over 15 feet long must also have an anti-siphon air vents (stand pipes), installed ahead of the horizontal runs. Extremely long horizontal runs may require oversized drain lines to eliminate air trapping.

Route primary drain line to the outside or to a floor drain. Check local codes before connecting to a waste (sewer) line.

Route the secondary drain line to a place in compliance with local installation codes where it will be noticed when unit is operational. Condensate flowing from secondary (overflow) drain indicates a plugged primary drain - unit requires service or water damage will occur.

 **CAUTION**

PRODUCT or PROPERTY DAMAGE HAZARD

Failure to follow this caution may result in product or property damage.

Use only full size P-traps in the condensate line (refer to Figure 5). Shallow, running traps are inadequate and DO NOT allow proper condensate drainage (refer to Figure 6).

Prime all traps, test for leaks, and insulate drain lines where sweating could cause water damage. Consult local codes for additional requirements or precautions.

If a gravity drain cannot be used, install a condensate pump. Install the pump as close to the indoor section as possible.

Be sure to install plastic push-in plugs in unused condensate drain holes.

⚠ CAUTION

PRODUCT DAMAGE HAZARD

Failure to follow this caution may result in poor unit performance and/or product damage.

Never operate unit without a filter. Factory authorized filter kits must be used when locating the filter inside the unit. For those applications where access to an internal filter is impractical, a field-supplied filter must be installed in the return duct system.

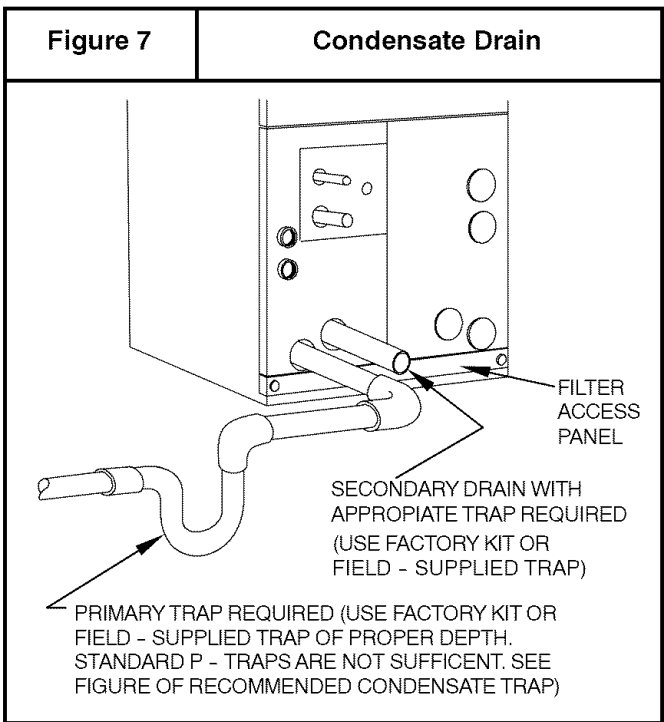
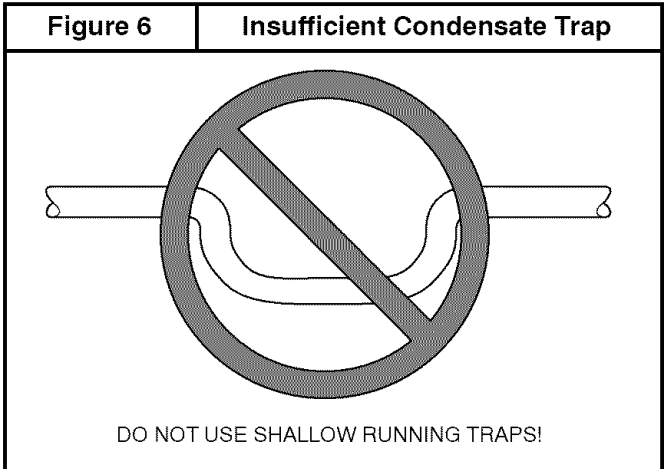
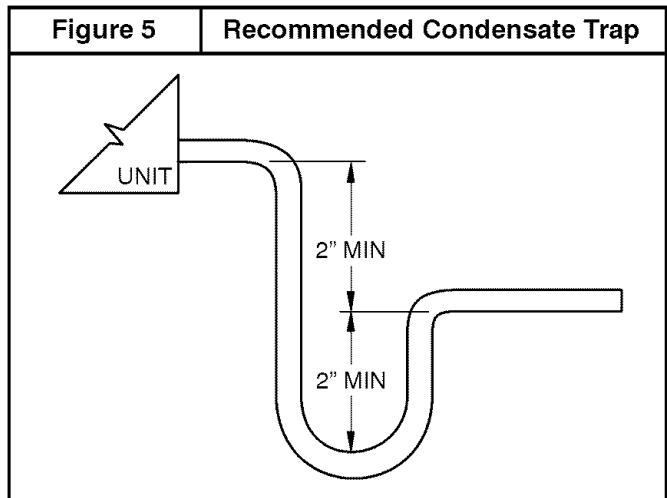

Figure 8

Wiring Layout - Cooling

- LEGEND
- 0 - AIRFLOW UNIT COMPONENT
 - ▭ 1A - INDICATOR
 - ▭ 1B - CONNECTION TERMINAL BOARD
 - ▭ 1C - A/C REFR. FLOW
 - ▭ 1D - LINE VOLTAGE TERMINAL BOARD
 - ▭ 1E - FIELD WINDING RELAY
 - ▭ 1F - TRANSFORMER
- AHX2400A1/3600A1
- FIELD WINDING REFRIGERATION CODE
- 1/4.0A THREE PHASE 60HZ 150V 1/5 C
 - 1/6.0A THREE PHASE 60HZ 150V 1/5 C
 - N/A

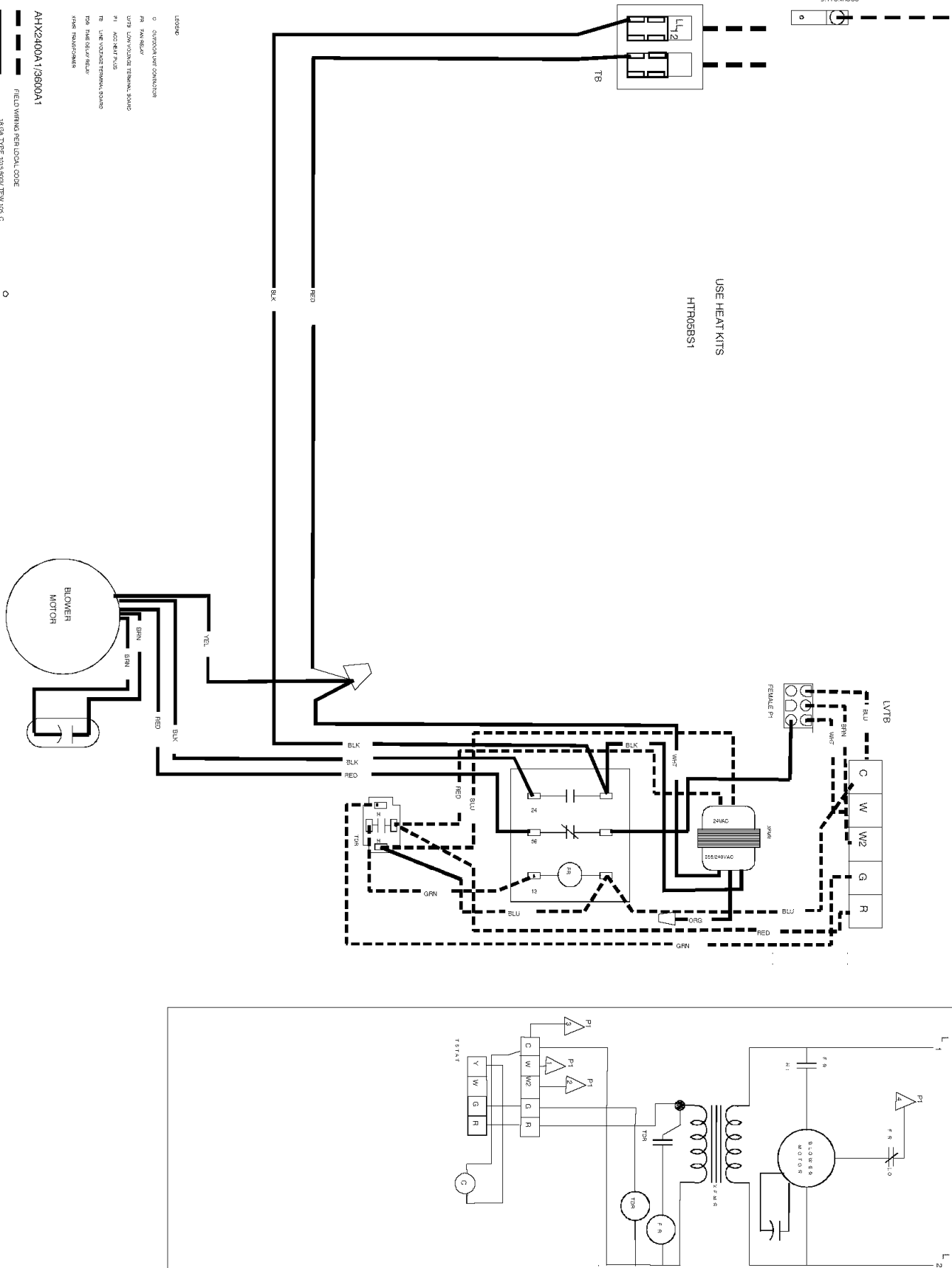
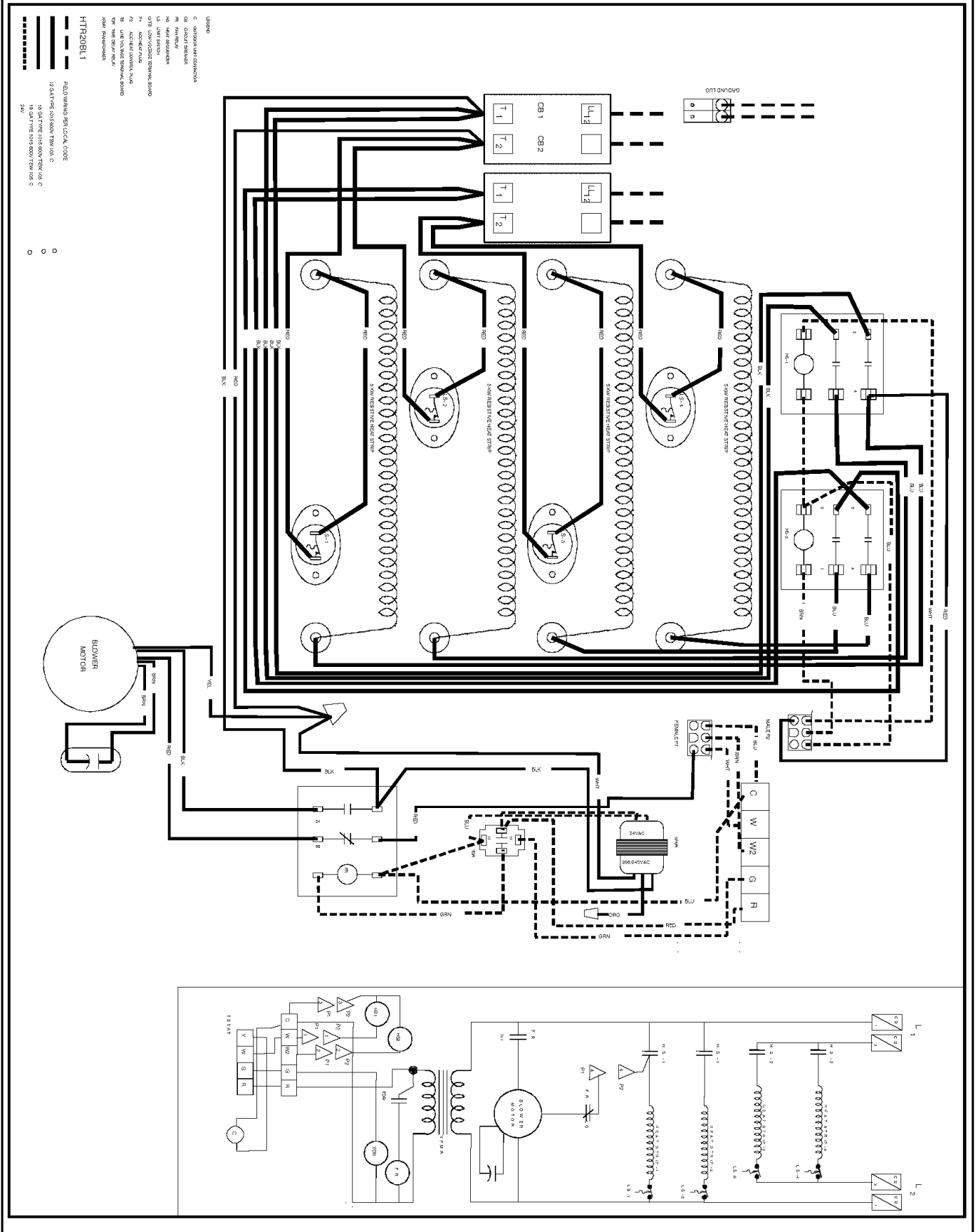

Figure 9

Wiring Layout - Electric Heating



SEQUENCE OF OPERATION

A. CONTINUOUS FAN

Thermostat closes R to G.

G energizes Time Delay Relay (TDR).

Time Delay Relay (TDR) energizes Fan Relay (FR) within 30 seconds.

When Fan Relay (FR) is energized, circuit is complete to Indoor Blower Motor.

When G is de-energized, there is a 3 second delay before Fan Relay (FR) opens.

B. COOLING MODE

Thermostat closes R to G, R to Y, and R to O (heat pump only).

G energizes Time Delay Relay (TDR). Y energizes Condense contactor, and O energizes the reversing valve (heat pump only)

Time Delay Relay (TDR) energizes Fan Relay (FR) within 30 seconds.

When Fan Relay (FR) is energized, circuit is complete to Indoor Blower Motor.

When G is de-energized, there is a 3 second delay before Fan Relay (FR) opens.

SAFETY SWITCHES

Unit is equipped with a limit switch for each separate heating element.

These switches are normally closed and are set to open at 170° F.

Blower continues running until unit has cooled enough (below set point) for switches to automatically reset.

C. HEATING MODE

Thermostat closes R to W and R to G.

W closes the Heat Sequencer(s) to switch line voltage from Terminals 1 and 4 to Terminals 3 and 5, which energizes the Heating Elements.

G energizes the Time Delay Relay (TDR).

Time Delay Relay (TDR) energizes Fan Relay (FR) within 30 seconds.

When Fan Relay (FR) is energized, circuit is complete to Indoor Blower motor.

When G is de-energized there is a 3 second delay.

CARE AND MAINTENANCE

The system should be regularly inspected by a qualified service technician. Consult the servicing dealer for recommended frequency.

Between visits, the only consumer service recommended or required is air filter maintenance and condensate drain operation.

Air Filter

Air handlers are factory equipped with an air filter. If the return grille has its own filter, it is not recommended to install a filter in the Air handler.

Inspect air filters at least monthly and replace or clean as required. Disposable type filters should be replaced. Reusable type filters may be cleaned by soaking in mild detergent and rinsing with cold water. Install filters with the arrows on the side pointing in the direction of air flow.

Condensate Drain

During the cooling season check at least monthly for free flow of drainage and clean if necessary.

AHX3 Series

NOTE: This illustration is for reference only. Your unit may differ in appearance or may not include all components shown.

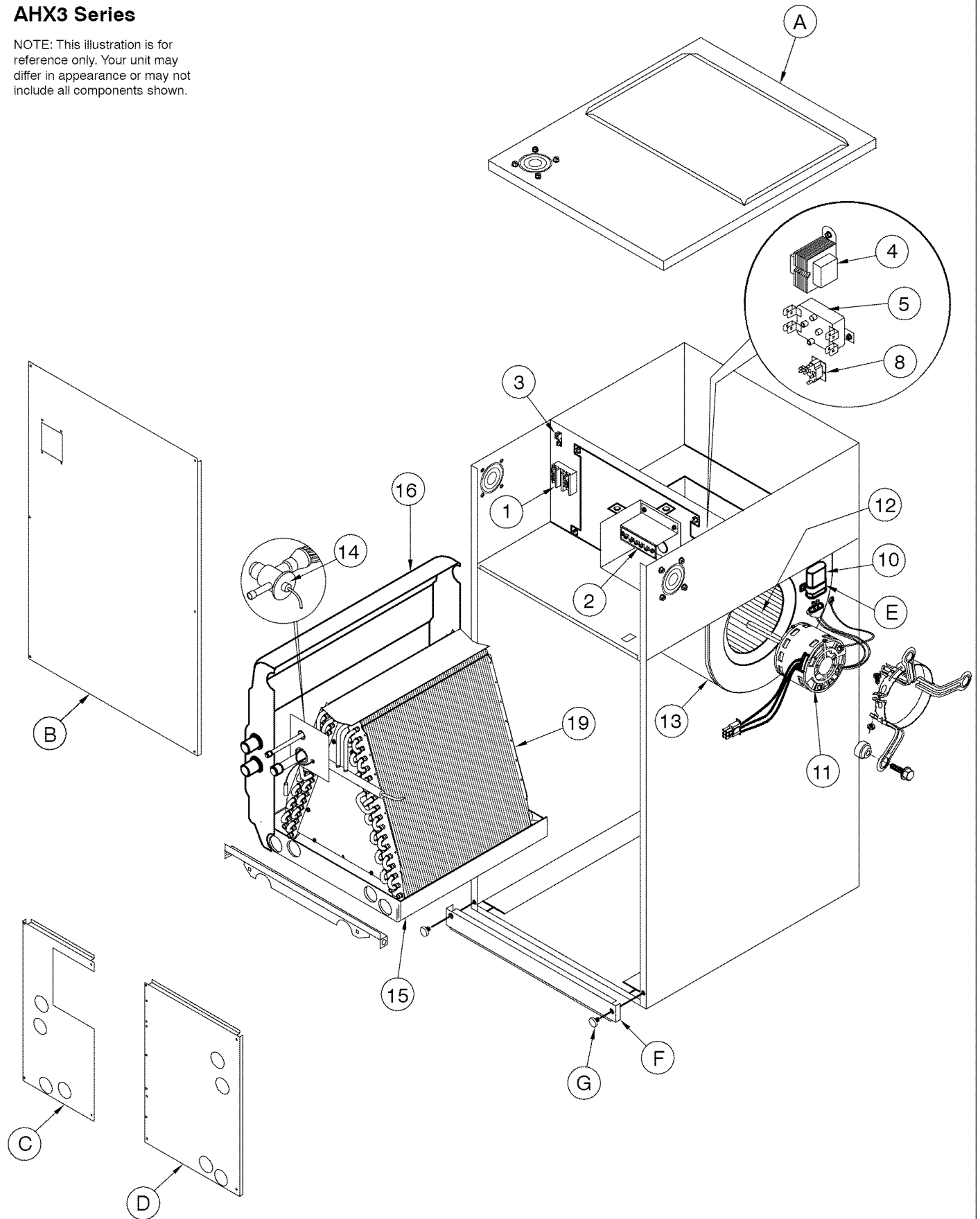

38-11-87a

REPLACEMENT PARTS - AHX3

AHX3 PARTS LIST

KEY NO.	DESCRIPTION	PART NO.	AHX32400A1	AHX33600A1	AHX34800A1	AHX36000A1
1	BOARD TERMINAL LINE VOLT	R68DC0018	1	1	1	1
2	BOARD TERMINAL LO VOLT	R68DC0017	1	1	1	1
3	GROUND LUG	R68DC0001	1	1	1	1
4	TRANS 208/240 24 40VA	R68AA0003	1	1	1	1
5	RELAY BLOWER DPDT	R68AB0001	1	1	1	1
8	RELAY TIME DELAY	R68AC0003	1	1	1	1
10	CAPACITOR 370 V 10 MFD	R68DE0001	-	1	1	-
10	CAPACITOR 370 V 15 MFD	R68DE0002	-	-	-	1
10	CAPACITOR 370 V 5 MFD	R68DE0003	1	-	-	-
11	MOTOR BLR 1/230 1/3	R65BP0014	-	1	1	-
11	MOTOR BLR 1/230 3/4	R65BP0006	-	-	-	1
11	MOTOR BLR 1/230 1/4	R65BP0016	1	-	-	-
12	WHEEL DD 10 X 6	R69AC0001	1	-	-	-
12	WHEEL DD 10 X 7	R69AC0002	-	1	-	-
12	WHEEL DD 10 X 8	R69AB0001	-	-	1	-
12	WHEEL DD 11 X 9	R69AC0003	-	-	-	1
13	BLOWER ASSY	BRA3441	-	1	-	-
13		BRA4541	1	-	-	-
13		BRA5515	-	-	1	-
13		BRA51-15	-	-	-	1
14	VALVE TXV 1.5-3.0	R72DB0005	1	1	-	-
14	VALVE TXV 3.0 - 5.0	R72DB0006	-	-	1	1
15	PAN DRAIN VERTICAL	R71AA0015	-	-	1	-
15		R71AA0026	1	1	-	-
15		R71AA0028	-	-	-	1
16	PAN DRAIN HORIZONTAL	R71AA0029	1	1	-	-
16		R71AA0031	-	-	1	-
16		R71AA0045	-	-	-	1
19	EVAP. COIL	CA024A862T41A	1	-	-	-
19		CA036A8E2T41A	-	1	-	-
19		CA048A6E5X15A	-	-	1	-
19		CA060A6E5X15A	-	-	-	1
*	GASKET/WASHER TEFLON	R72BA0003	1	1	1	1
*	STUB KIT 3/8"	R86FJ0202	1	1	1	1
A	TOP PANEL	R87IAE017	1	1	-	-
A		R87IX0013	-	-	1	1
B	BLOWER/CONT. BOX DOOR	R87IFC001	1	1	-	-
B		R87IXB001	-	-	1	1
C	CLOSURE DOOR	R87IFBX07	1	1	-	-
C		R87IXA004	-	-	1	1
D	ACCESS DOOR	R87IFBX08	1	1	-	-
D		R87IXA005	-	-	1	1
E	CAPACITOR CLAMP	R87NBK001	1	1	1	1
F	FILTER DOOR	R87IBA012	1	1	-	-
F		R87IZ0010	-	-	1	1
G	THUMB SCREW	R66AB0022	2	2	2	2

* Part not shown, available through FAST