



BCC/BCQ 018, 024 Duct Free Systems

Installation, Start-Up and Service Instructions

CONTENTS

	Page
SAFETY CONSIDERATIONS	1
GENERAL	1-6
INSTALLATION	6-13
Indoor Unit Installation	6
Outdoor Unit Installation	8
Power Supply	9
Leak Test	9
Wiring Diagrams	11-12
START-UP	13
System Checks	13
CARE AND MAINTENANCE	13
Outdoor Units	13
Indoor Units	13
To Clean the Indoor Unit Front Panel	13
To Clean Indoor Coil	13
Air Filters for Indoor Units	13
SERVICE	13
TROUBLESHOOTING	14-17

SAFETY CONSIDERATIONS

Installing, starting up, and servicing air-conditioning equipment can be hazardous due to system pressures, electrical components, and equipment location (roofs, elevated structures, etc.).

Only trained, qualified installers and service mechanics should install, start-up, and service this equipment.

Untrained personnel can perform basic maintenance functions such as cleaning coils. All other operations should be performed by trained service personnel.

When working on the equipment, observe precautions in the literature and on tags, stickers, and labels attached to the equipment.

Follow all safety codes. Wear safety glasses and work gloves. Keep quenching cloth and fire extinguisher nearby when brazing. Use care in handling, rigging, and setting bulky equipment.

WARNING

Before installing or servicing system, always turn off main power to system and install lockout tag on disconnect. There may be more than one disconnect switch. Electrical shock can cause personal injury.

GENERAL

These instructions cover the installation, start-up and servicing of 38BCC/BCQ outdoor and 40BNC/BNQ indoor units cooling only and heat pump duct free systems. See Table 1 for parts included. See Tables 2 and 3 for Physical Data.

System Requirements

IMPORTANT: The Indoor units & the inter units cable voltage is 30 VDC.

IMPORTANT: Each refrigerant line must be insulated Separately. See line sizing requirements in tabel 2.

- Consult local building codes and National Electrical Code (NEC, U.S.A.) for special installation requirements.

Max. cable length. Total voltage drop should not exceed 1V. Therefore max. length:

For #18 AWG	24.3 Feet (7.4 m)
For #16 AWG	37.7 Feet (11.5 m)
For #14 AWG	50.0 Feet (18 m)

- Use only type "G" or "C" fuses. Use single length power cable without extension. Allow sufficient space for airflow clearance on condensing units for wiring, refrigerant piping, and servicing unit. See Fig. 1 and 2 for minimum required distances between unit and walls or ceilings.
- **Indoor and outdoor units should be installed at a Minimum length of 10 ft. apart. Maximum line length of 50 ft. and vertical separation of 30 ft.**
- Do not install indoor units near a direct source of heat such as direct sunlight, steam or flame.

CAUTION

Do not bury more than 36 in. of refrigerant pipe in the ground. If any section of pipe is buried, there must be a 6 in. vertical rise to the valve connections on the outdoor units. If more than the recommended length is buried, refrigerant may migrate to the cooler buried section during extended periods of system shutdown. This causes refrigerant slugging and could possibly damage the compressor at start-up.

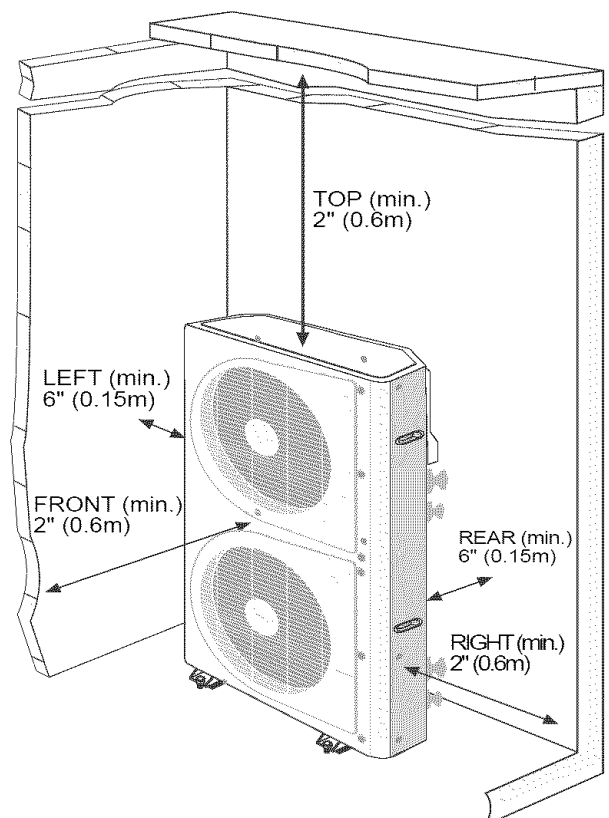

Fig. 1 — 38BCC/BCQ 018, 024 Outdoor Unit Clearances

Table 1 — Parts List — High Wall Units





ITEM	QTY	DIAGRAM
Mounting Bracket	2 X 1	 <p>40BNC/BNQ 009, 012</p>
Long Screws	2 X 8	
Outdoor Sensor Connecting Cable	2 X 1	 <p>(Available for HEAT PUMP ONLY)</p>
Absorption Cushions	4	
Electric Terminals	2 X 8	
Remote Controller Mounting Bracket	2 X 1 Mounting Bracket with 2 screws	
Remote Controller and Batteries	2 X 1	
Insulation for indoor Fittings	2 X 1	
Owner's Manual	2 X 1	
Wall mounted Receiver RTX	1 (OPTIONAL) (Not included)	

Table 2 - Physical Data - Cooling Only

INDOOR UNIT	2 X 40BNC009	2 X 40BNC012
COOLING CAPACITY (Btuh)	2 X 9,000	2 X 11,400
SEER	13.0	13.0
SYSTEM CHARGE (lb)*	2 X 2.4	2 X 3.1
MOISTURE REMOVAL (pt/hr)	2 X 2.6	2 X 4.5
AIRFLOW (3 Speeds) High / Med. / Low Cfm	2 X 350 / 2 X 280 / 2 X 220	2 X 370 / 2 X 280 / 2 X 220
DIMENSIONS LxHxW (in.)	32 3/32x10 15/64x7 9/32	32 3/32x10 15/64x7 9/32
REFRIGERANT TYPE	R-22	R-22
NET WEIGHT (lb)	2 X 19.0	2 X 19.0
OUTDOOR UNIT		
	38BCC018	38BCC024
TUBE CONNECTIONS Vert Lift/Vert Drop/Max Length (ft)	30/30/50	30/30/50
NOMINAL LINE SIZING Mixed Phase...Suction (in.)	1/4...1/2	1/4...1/2
COMPRESSOR TYPE	Panasonic-2R13S126A6F	Panasonic-2P17SR126B1A
DIMENSIONS LxHxW(in.)	35.5 X 49.5 X 12.6	35.5 X 49.5 X 12.6
NET WEIGHT (lb)	226	228
METERING TYPE	Piston (Accurator)	Piston (Accurator)
LEGEND	Accurator is non-serviceable	

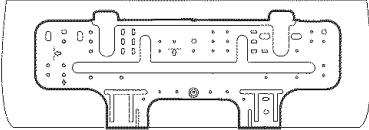
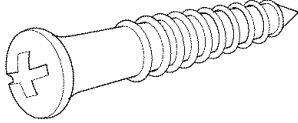
SEER — Seasonal Energy Efficiency Ratio

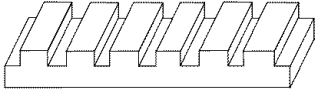
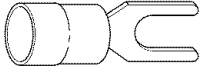
*Units are shipped with a factory charge based on 25 ft of refrigerant lines.

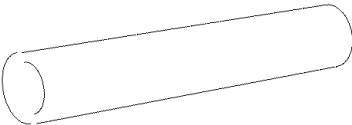
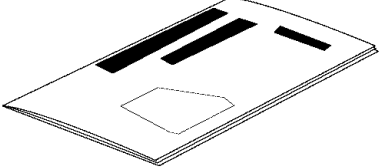
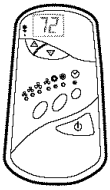
Table 3 - Physical Data - Heat Pump

INDOOR UNIT	2 X 40BNQ009	2 X 40BNQ012
COOLING CAPACITY (Btuh)	2 X 9,000	2 X 11,400
SEER	13.0	13.0
HEATING CAPACITY (Btuh)	17,200	23,600
HSPF	7.7	7.7
SYSTEM CHARGE* (lb)	2 X 2.4	2 X 3.1
MOISTURE REMOVAL (pt/hr)	2 X 2.6	2 X 4.5
AIRFLOW (3 Speeds) High / Med. / Low Cfm	2 X 350 / 2 X 280 / 2 X 220	2 X 370 / 2 X 280 / 2 X 220
DIMENSIONS LxHxW (in.)	32 3/32x10 15/64x7 9/32	32 3/32x10 15/64x7 9/32
REFRIGERANT TYPE	R-22	R-22
NET WEIGHT (lb)	2 X 19.0	2 X 19.0
OUTDOOR UNIT		
	38BCQ018	38BCQ024
TUBE CONNECTIONS Vert Lift/Vert Drop/Max Length (ft)	30/30/50	30/30/50
NOMINAL LINE SIZING Mixed Phase...Suction (in.)	1/4...1/2	1/4...1/2
COMPRESSOR TYPE	Panasonic-2R13S126A6F	Panasonic-2P17SR126B1A
DIMENSIONS LxHxW (in.)	35.5 X 49.5 X 12.6	35.5 X 49.5 X 12.6
SHIPPING WEIGHT (lb)	226	228
METERING TYPE	Piston (Accurator)	Piston (Accurator)
LEGEND	Accurator is non-serviceable	

HSPF - Heating Seasonal Performance Factor

SEER - Seasonal Energy Efficiency Ratio

*Units are shipped with a factory charge based on 25 ft of refrigerant lines.

NOTE: Standard Ambient Operating Limitations - 55 °F to 125 °F (12.7 °C to 51.6 °C).



UNITED TECHNOLOGIES
CARRIER

P O BOX 4808
SYRACUSE N. Y.
13221

THIS DOCUMENT IS THE PROPERTY OF CARRIER CORPORATION AND IS DELIVERED UPON THE EXPRESS CONDITION THAT THE CONTENTS WILL NOT BE DISCLOSED OR USED WITHOUT CARRIER CORPORATION'S WRITTEN CONSENT.

SUBMISSION OF THESE DRAWINGS OR DOCUMENTS DOES NOT CONSTITUTE PART PERFORMANCE OR ACCEPTANCE OF CONTRACT

UNIT		A	B	C	D	E	F	G	H	L	K	Weight
40BNC009	[Inch]	32.08	10.23	7.28	25	9.06	1.57	1/2	1/4	1.06	1.96	18.7 lb
40BNQ009	[mm]	(815)	(260)	(185)	(635)	(230)	(40)	(12.7)	(6.35)	(27)	(50)	(8.5) Kg
40BNC012	[Inch]	32.08	10.23	7.28	25	9.06	1.57	1/2	1/4	1.06	1.96	18.7 lb
40BNQ012	[mm]	(815)	(260)	(185)	(635)	(230)	(40)	(12.7)	(6.35)	(27)	(50)	(8.5) Kg

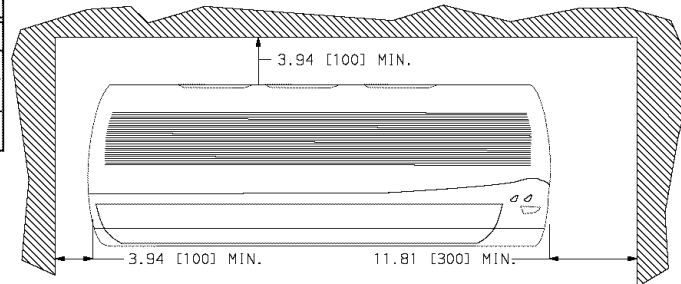

TOP VIEW

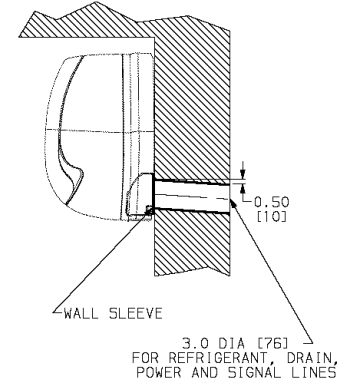

MINIMUM CLEARANCE FOR SERVICE AND AIR FLOW

- NOTES:
1. DIMENSIONS IN INCHES, [] ARE IN MILLIMETERS - DO NOT SCALE.
 2. DIRECTION OF AIR FLOW.
 3. REFRIGERANT, DRAIN AND POWER CONNECTIONS MAY BE MADE REAR (LEFT OR RIGHT), LEFT SIDE, RIGHT SIDE, OR BOTTOM LEFT.

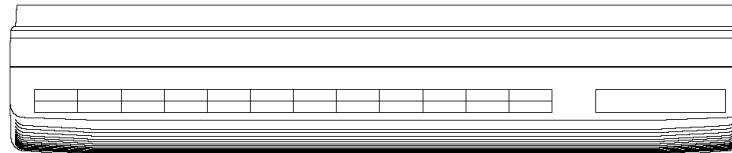

FRONT VIEW

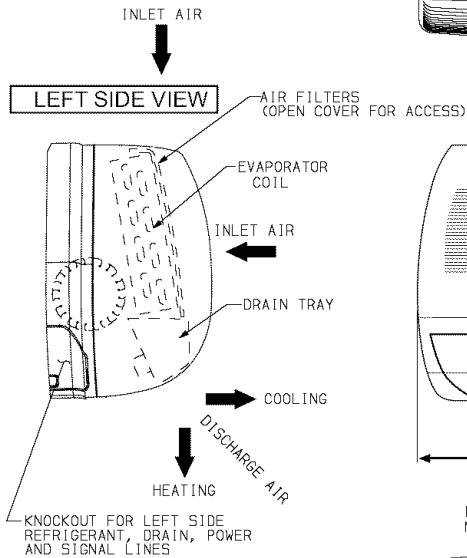

LEFT SIDE VIEW

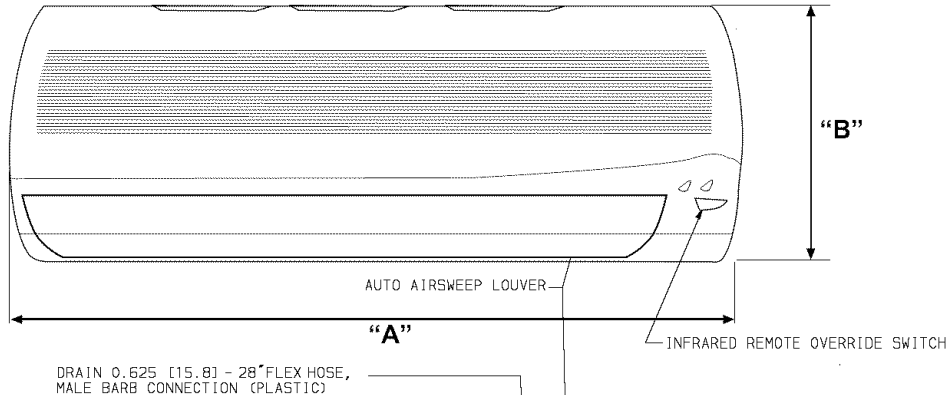

BOTTOM VIEW

RIGHT SIDE VIEW

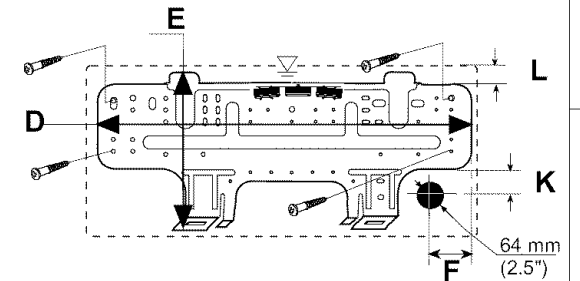
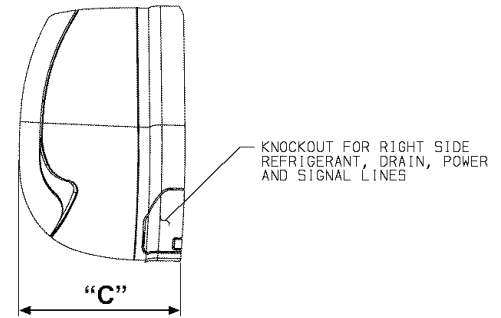

DATE: 20/06/2006
ENGINEER: GAD L
DRAFTER: EITANO
SUPERVISOR: NEW
TITLE:

4



UNITED TECHNOLOGIES CARRIER

P O BOX 4809
SYRACUSE N. Y.
13221

THIS DOCUMENT IS THE PROPERTY OF CARRIER CORPORATION AND IS DELIVERED UPON THE EXPRESS CONDITION THAT THE CONTENTS WILL NOT BE DISCLOSED OR USED WITHOUT CARRIER CORPORATION'S WRITTEN CONSENT.

SUBMISSION OF THESE DRAWINGS OR DOCUMENTS DOES NOT CONSTITUTE PART PERFORMANCE OR ACCEPTANCE OF CONTRACT

UNIT SIZE	A		B		C		D		E		F		G		J1		J2		K1		K2		L		M		N		P (SUCTION FLARE)		R (LIQUID FLARE)		OPERATING WGT.		DATE 30/06/06
	INCHES.	[mm]	INCHES.	[mm]	INCHES.	[mm]	INCHES.	[mm]	INCHES.	[mm]	INCHES.	[mm]	INCHES.	[mm]	INCHES.	[mm]	INCHES.	[mm]	INCHES.	[mm]	INCHES.	[mm]	INCHES.	[mm]	INCHES.	[mm]	INCHES.	[mm]	INCHES.	[mm]	LBS.	[kg]			
38BCC018101 38BCQ018101	49.5	1257	35.4	900	12.6	320	14.0	355	24.7	628	14.9	378	5.35	136	4.3	109	28.6	726	7.75	197	32.0	813	2.12	54	37.7	957	39.7	1008	1/2	12.7	1/4	6.35	226	102.5	
38BCC024101 38BCQ024101	49.5	1257	35.4	900	12.6	320	14.0	355	24.7	628	14.9	378	5.35	136	4.3	109	28.6	726	7.75	197	32.0	813	2.12	54	37.7	957	39.7	1008	1/2	12.7	1/4	6.35	228	103.4	

ENGINEER
ETANIC

DRAWER
ETANIC

SUPERSEDES
NEW

38BCC/BCQ 018/024 101
CONDENSING UNITS

REV

NOTES:

- REQUIRED CLEARANCES, WITH COIL FACING WALL - ALLOW 6" MINIMUM
 - WITH COIL FACING WALL - ALLOW 6" MINIMUM CLEARANCE ON COIL SIDE & END, AND 2 FEET MINIMUM CLEARANCE ON COMPRESSOR END FAN SIDE.
 - WITH FAN FACING WALL - ALLOW 2" MINIMUM CLEARANCE ON FAN SIDE AND 6" ON COIL END, AND 2 FEET MINIMUM CLEARANCE ON COMPRESSOR END COIL SIDE.
 - ALLOW 2 FEET MINIMUM CLEARANCE OVER THE TOP OF UNIT.
 - WITH MULTI-UNIT APPLICATION, ARRANGE UNITS SO DISCHARGE OF ONE DOES NOT ENTER INLET OF OTHER.
- DIMENSIONS IN PARENTHESIS ARE IN METRIC.
- BRACKET WITH 1.125" DIA. HOLE FOR FIELD POWER SUPPLY.

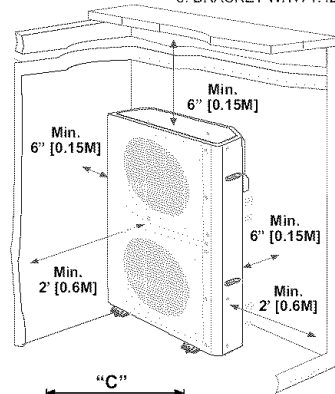
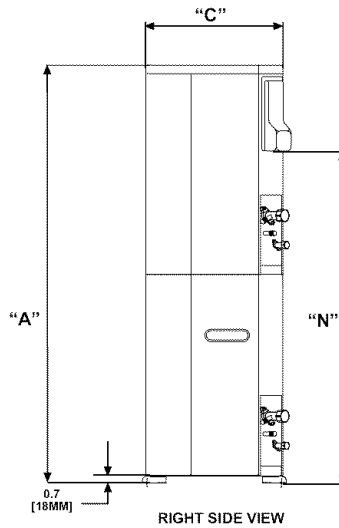
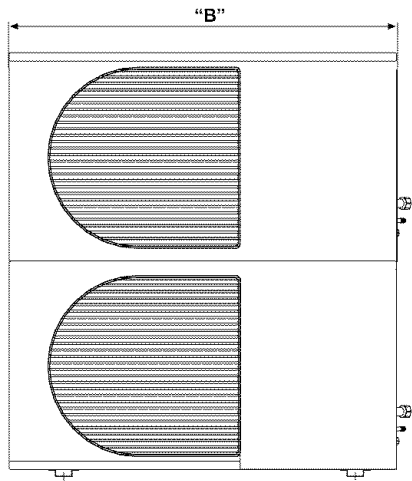
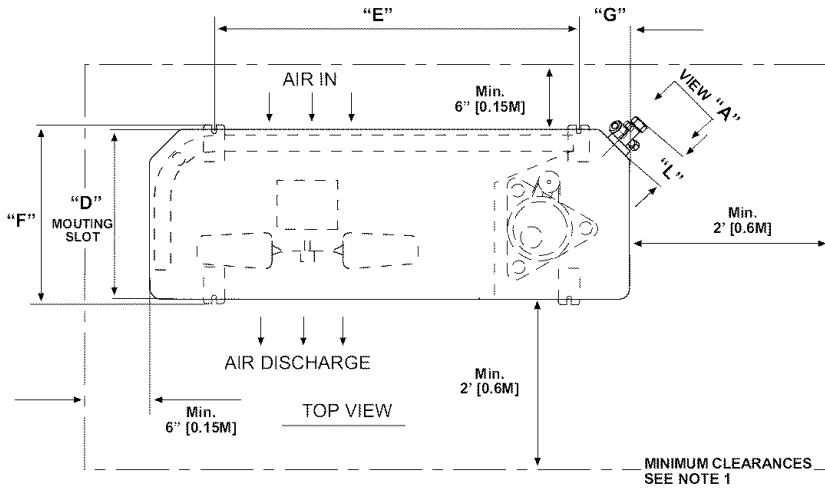

FIELD POWER CONNECTION & CONTROL CONNECTION UNDER THIS COVER

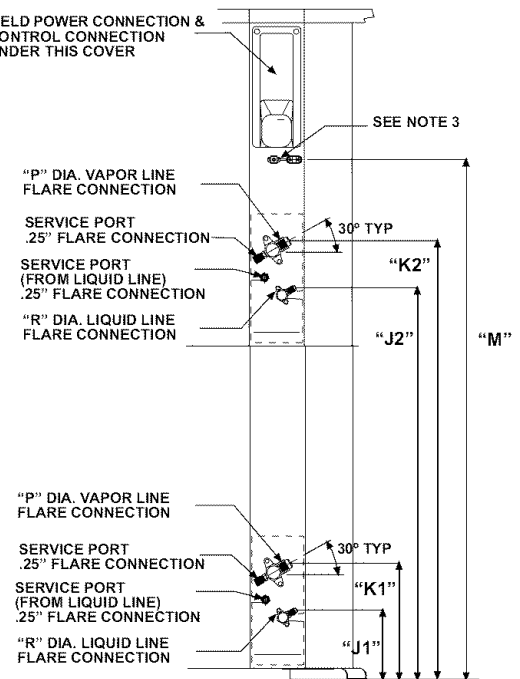

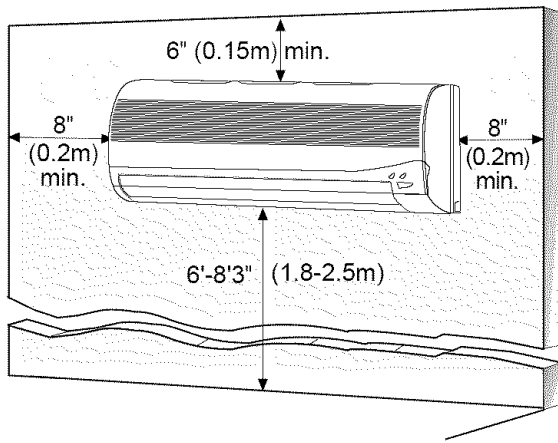

Fig. 2 — Indoor Unit Clearances

INSTALLATION

Plan the installation carefully to avoid component failures and make installation easier.

Indoor Unit Installation

REFRIGERANT LINE ROUTING — The refrigerant lines may be routed in any of the four directions shown in Fig. 3.

INSTALL THE MOUNTING BRACKET

1. Carefully remove the mounting bracket, which is connected to the back of the indoor unit's base with screws.
2. Position the mounting bracket on the wall and level it using a spirit level (see Fig. 2 for minimum required clearance distances).
3. Mark the four drilling holes on the wall, as they appear in Fig. 4.
4. Drill the holes, insert the wall plugs and use four long screws to attach the mounting bracket to the wall.
5. Check that the bracket is leveled and securely fastened to the wall.

DRILL A HOLE IN THE WALL FOR DRAINAGE AND INTER-UNIT CONNECTIONS-

To make the connections between the indoor and outdoor units, drill a 2.5-in. hole through the wall for the refrigerant lines, drainage hose and control cable passage as shown in Fig. 5.

1. Mark the center of the hole to be drilled according to the refrigerant line routing used and dimensions shown in Fig. 4.
2. Make sure to drill outwards and downwards, so that the opening in the outside wall is at least 1/2" lower than the opening on the inside.
3. Make sure the drainage hose is at the bottom side of the hole.
4. If refrigerant line route no. 1,2 or 4 are used, use a small saw blade to carefully remove the corresponding plastic covering on the side panel.
5. Run the outdoor sensor cable, electrical cable, refrigerant lines, and drainage tube through the hole.
6. Fill the remaining wall hole gap with an appropriate sealant material.

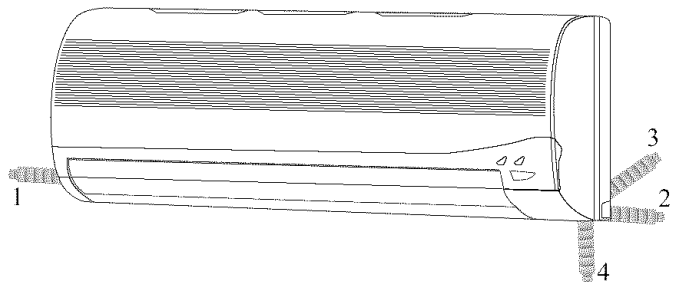

Fig. 3 — Refrigerant Lines

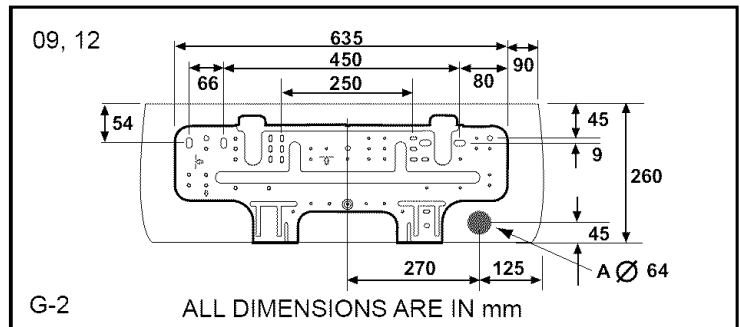
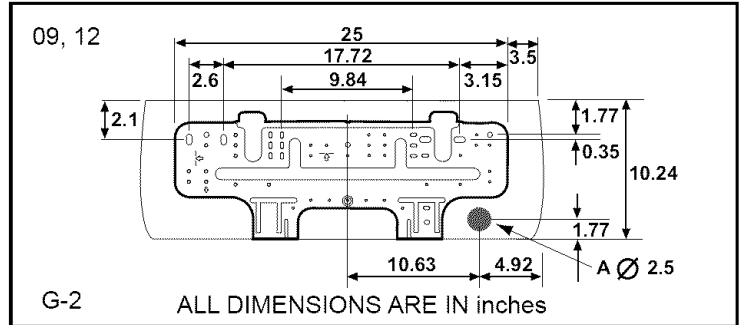

Fig. 4 — Mounting Bracket 38BNC/BNQ 009, 012

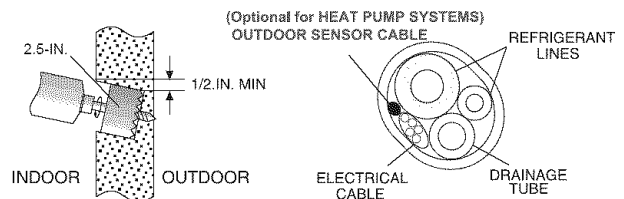

Fig. 5 — Drill Holes

WIRE THE INDOOR UNIT

1. Strip the cables back 1/4 inch.
2. Remove the unit's front panel by lifting the lower part and pulling it gently outward and upward. See Fig. 6.
3. Remove the two screws from the control box cover and take off the cover. See Fig. 7. Save the screws to reassemble.

NOTE: In general wiring the indoor unit does not require the removal of the grille frame but in case of need do as follow:

4. Remove the two screws from the air discharge opening. Save the screws to reassemble. See Fig. 7A.
- Pull downwards and outward from the bottom of the grille and gently raise the frame of the top of the unit.
- Once all covers are off, mount the unit onto the wall mounting bracket. See Fig. 8.

NOTE: Leave covers off until after the Making Drainage Connections section.

- Route the interconnecting unit's electric cable and the outdoor sensor cable towards the lower right hand corner of the indoor unit.
- Make sure that the wires are connected in accordance with the wiring diagram on the inside of the unit front cover or within this instruction manual.
- Secure the control cables to the strain relief.
- For heat pump systems only, connect the outdoor sensor TH3 to its mating black terminal. See Fig. 9.



CAUTION

Make sure that all wires and screws are firmly fastened. Loose wires or connections can cause damage and present a fire hazard.

MAKE DRAINAGE CONNECTIONS

1. Connect the unattached end of the drainage tube to the drainage hose outlet.
2. Seal the drainage connection to prevent leakage.
3. Make sure there are no kinks, "U" bends or flattened sections in the tube.
4. Check that the drainage functions properly. Fill the pan below the unit's coil with water and observe that it freely drains out.
5. Make sure the drainage hose is at the bottom side of the wall through-hole (see Fig. 5).

REASSEMBLE

1. Connect the display connector to the display panel printed circuit board.
2. Put the control box cover and grille frame back on using the appropriate screws (Steps 3 and 4 of Wire the Indoor Unit section). Put the grille insert back on.

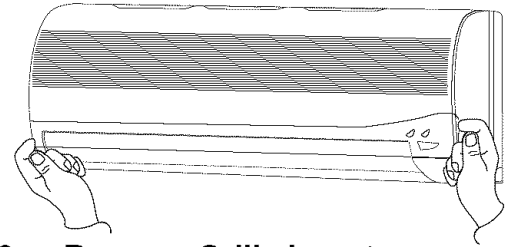

Fig. 6 — Remove Grille Insert

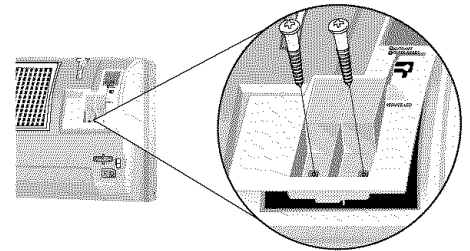

Fig. 7 — Remove Control Cover

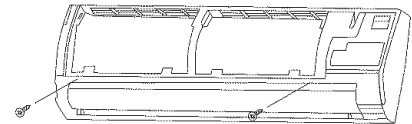
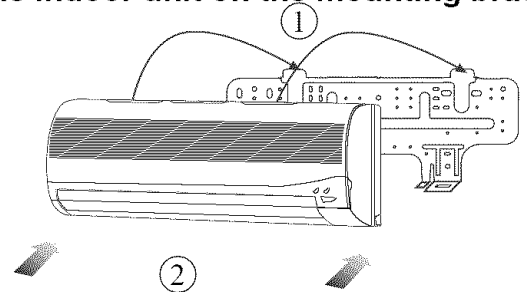

Fig. 7A - Remove the screws from the air discharge opening.

Mount the indoor unit on the mounting bracket



Gently push with the arrow direction

Fig. 8 — Indoor Unit Mounting

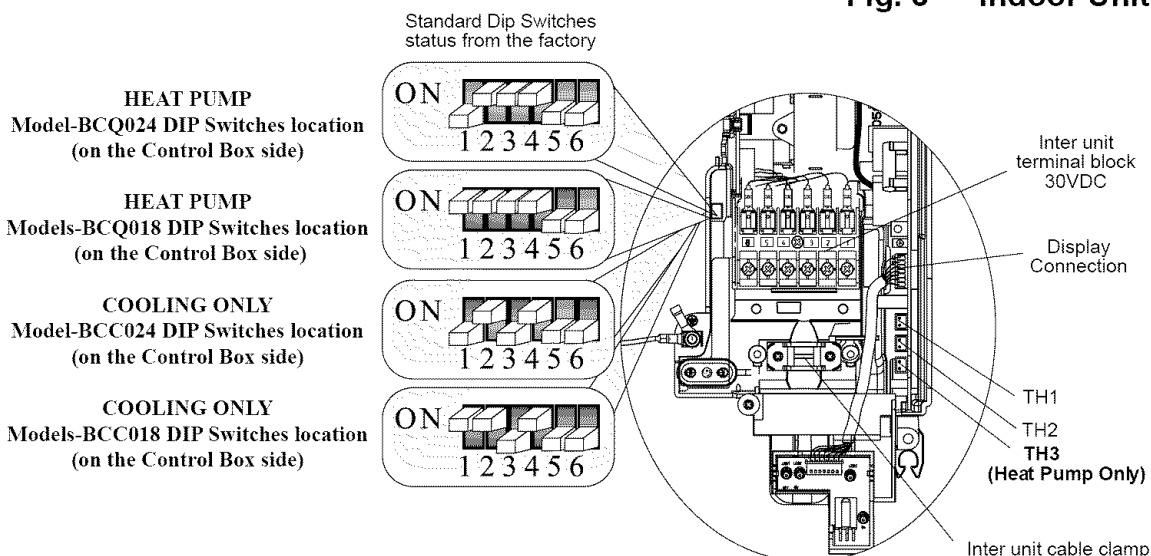

Fig. 9 — Outdoor Sensor Connection

ATTACH THE REMOTE CONTROLLER MOUNTING BRACKET

1. Use the two screws supplied with the controller to attach the mounting bracket to the wall in the location selected by the customer (see Fig. 10).
2. Install batteries in the remote control.
3. Place remote control into remote control mounting bracket.
4. For remote control operation, refer to the unit Owner's Manual.

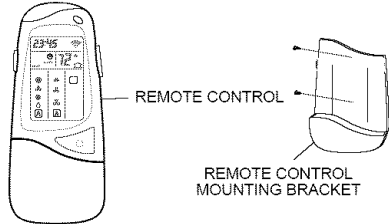

Fig. 10 — Attach Mounting Bracket to the Wall

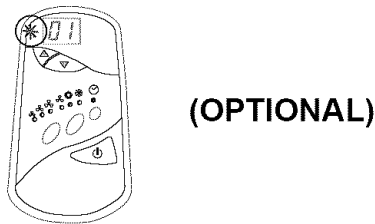

Fig. 11 — Wall Mounted Unit - RTX

Outdoor Unit Installation

NOTE: The outdoor unit must be installed on a solid surface (mounting base).

1. Place the rubber absorption cushions (supplied with the outdoor unit) under the unit's feet to prevent vibrations.
2. Fasten the outdoor unit legs to the mounting base, as shown in Fig. 12. The cushion goes between the legs and the mounting base.
3. Be sure that the unit is leveled.

MAKE REFRIGERANT PIPING CONNECTIONS (OUTDOOR UNIT) — To connect the refrigerant lines:

Make sure to properly identify and separate between the piping and control cables coming from indoor unit No. 1 and the piping and cables coming from indoor unit No. 2

Use only "L" type sealed, dehydrated copper refrigerant tubing. No other type of tubing may be used. Use of other types of tubing will void the manufacturer's warranty.

Do not open service valves or remove protective caps from tubing ends until all the connections are made.

Bend tubing with special bending tools to avoid the formation of sharp bends. Take care to avoid kinks or flattening of the tubing.

Keep the tubing free of dirt, sand, moisture, and other contaminants to avoid damaging the refrigerant system.

Avoid sags in the suction line to prevent the formation of oil traps.

Insulate each tube with 3/8-in. walled thermal pipe insulation. Inserting the tubing into the insulation before making the connections will save time and improve installation. The suction and mixed-phase lines should never come in direct contact.

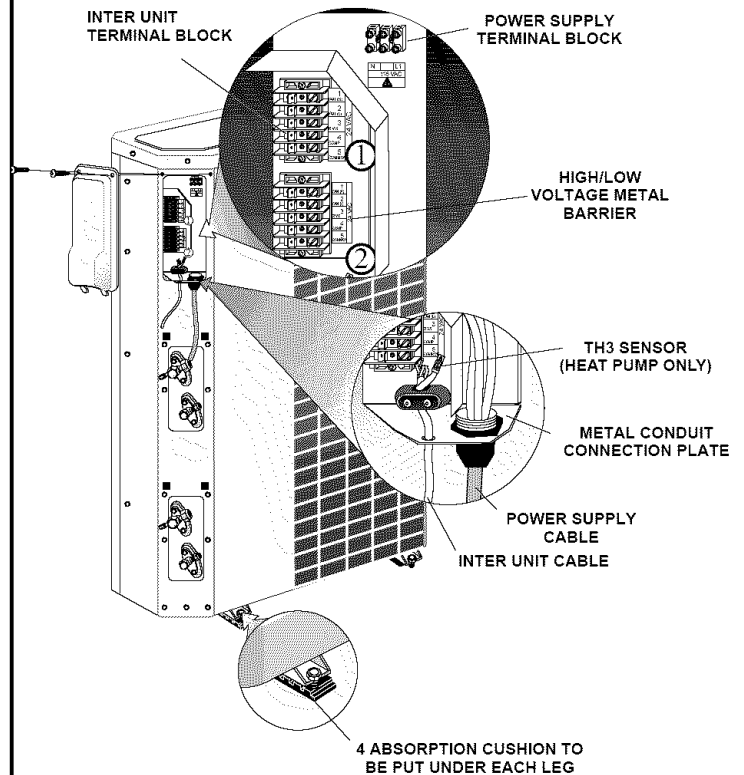

Fig. 12 — Legs Mounting Base and Wiring Outdoor Units Models: 38BCC/BCQ 018, 024

INDOOR UNIT BCC/BCQ018, 024

Operation push button for automatic operation (23°C/73°F), turning the a/c OFF, canceling the malfunction indication, and resetting the filter LED.

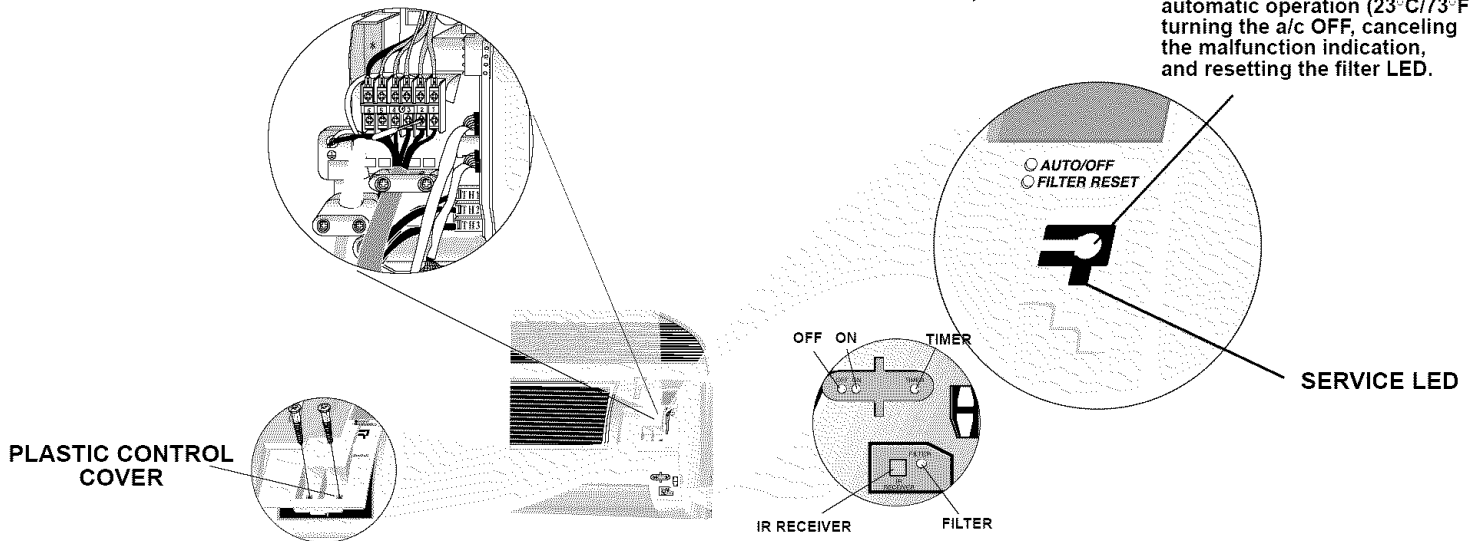

Fig. 12A — Indoor unit LED's and Wiring

FLARING AND CONNECTING REFRIGERANT LINES

1. Remove the protective cap from the flare fitting.
2. Remove the protective cap from the tubing and cut to the required length. Be sure that the cut is perpendicular and clean, without burrs.
3. Slip the flare nut on the tubing and flare the tube end using standard flaring tools.
4. Tighten the nut until resistance is met. Mark the nut and the fitting. Using a suitable wrench tighten an additional 1/4 turn. Use the following specified torque, according to connection size:

Mixed-Phase line:	Suction line:
1/4 in.-(12.3 ft-lb.)	1/2 in.-(36 ft-lb.)

Both refrigerant lines need to be insulated separately

NOTE: The service valves on the outdoor unit must remain closed until all 4 connections have been made.

EVACUATE TUBING AND CHARGE THE SYSTEM — When all the fittings are connected, air must be expelled, then refrigerant charge must be checked and adjusted. Follow the steps below.

1. Open the service port cap on the suction line valve (large valve of unit No. 1).
2. Connect the vacuum pump to the service port of unit No. 1 via the pressure gage and evacuate to 500 microns to eliminate contamination and moisture.

3. Disconnect the vacuum pump. Unit should maintain 500 microns for 5 minutes.
4. Remove the service port caps from the mixed-phase valve and suction line valve
5. Open the mixed-phase valve (small valve) with an Allen wrench.
6. Open the suction line valve (large valve) with an Allen wrench.
7. To evacuate and charge unit No. 2 repeat steps 1 thru 6.
8. **The outdoor unit is supplied with sufficient R-22 refrigerant for up to 25 ft. lineset length. Add 0.9 oz. of refrigerant for each additional 3 ft. of tubing length.**
9. Make sure that the valves are properly opened. Be careful not to open them more than required as this may damage the thread.
10. Replace the service port cap. Using refrigerant oil, lubricate the cap beam and hand tighten until resistance is met. Use a suitable wrench to tighten the cap by an additional 1/2 turn.

Power Supply — See Tables 4 and 5 for electrical data and Fig. 13-14 for system wiring diagrams.

Leak Test — Leak test all fittings with appropriate test equipment.

Table 4 — Electrical Data, Indoor Units — 30VDC

UNIT		VOLTAGE	MCA*	MOCP*	FULL LOAD AMPS	FAN MOTOR AMPS	COMPRESSOR AMPS	COMPRESSOR LOCKED ROTOR AMPS
40BNC	009	30VDC	N/A	N/A	1.8	1.1	N/A	N/A
40BNQ	012	30VDC	N/A	N/A	1.8	1.5	N/A	N/A

LEGEND

MCA — Minimum Circuit Amps

MOCP — Maximum Overcurrent Protection

*If indoor unit is powered from outdoor terminal block, the MOCP for the outdoor unit is for both sections

NOTE: Specifications and performance data are subject to change without notice.



3095897

Table 5 — Electrical Data, Outdoor Units — 115, 1-60

UNIT		VOLTAGE	MCA*	MOCP*	FULL LOAD AMPS	FAN MOTOR AMPS	COMPRESSOR AMPS	COMPRESSOR LOCKED ROTOR AMPS
38BCC	018	115VAC	19.8	25	18	1.00	7.2	42
38BCQ	024	115VAC	24.6	30	22.2	1.00	9.3	58

LEGEND

MCA — Minimum Circuit Amps

MOCP — Maximum Overcurrent Protection

*If indoor unit is powered from outdoor terminal block, the MOCP for the outdoor unit is for both sections

NOTE: Specifications and performance data are subject to change without notice.



3095897

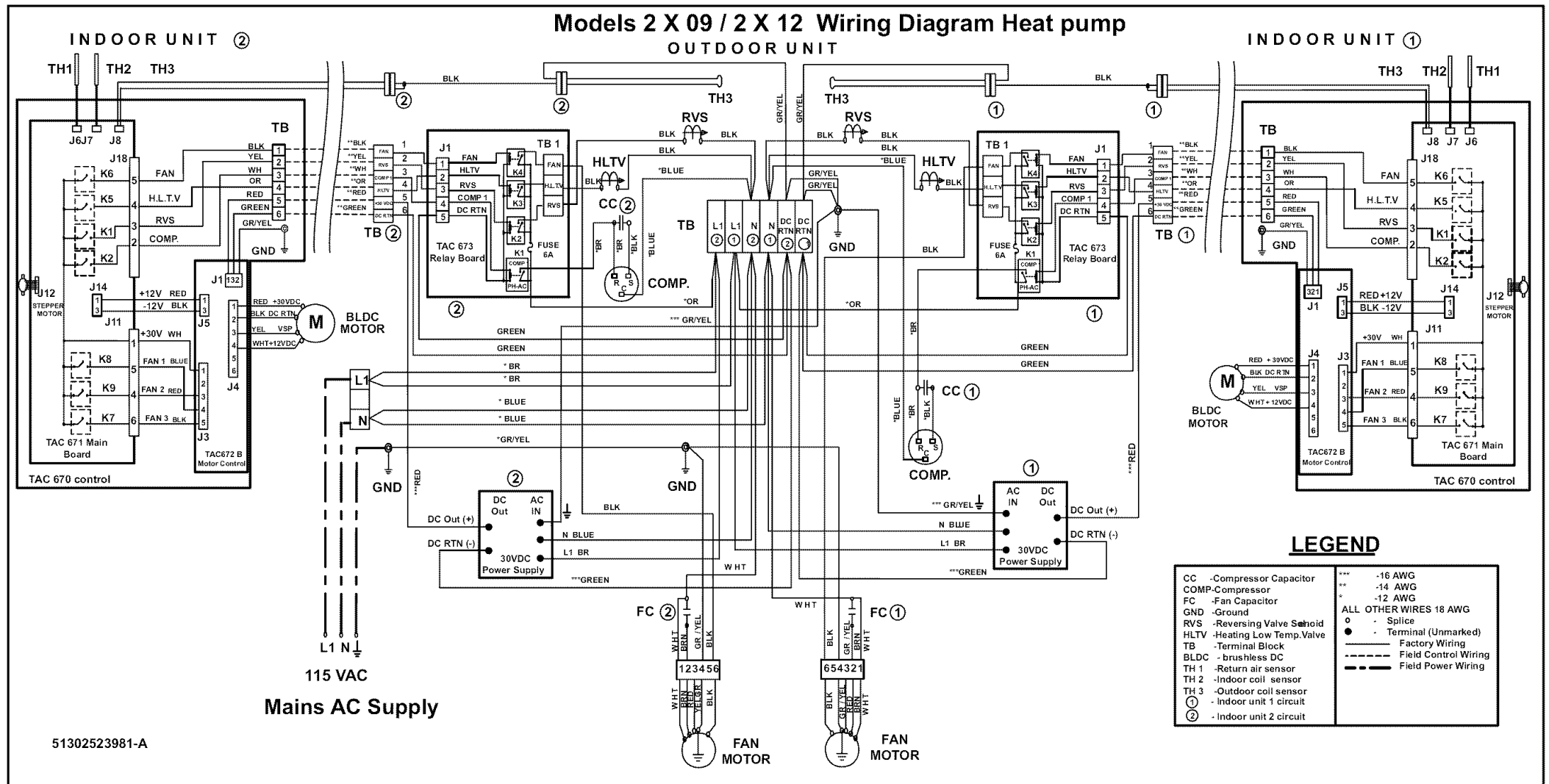

Fig. 13 System Wiring Schematic 40BNQ009, 40BNQ012 FAN COIL WITH 38BCQ018, 38BCQ024 Condensing Unit

Models 2 X 09 / 2 X 12 Wiring Diagram Cooling Only

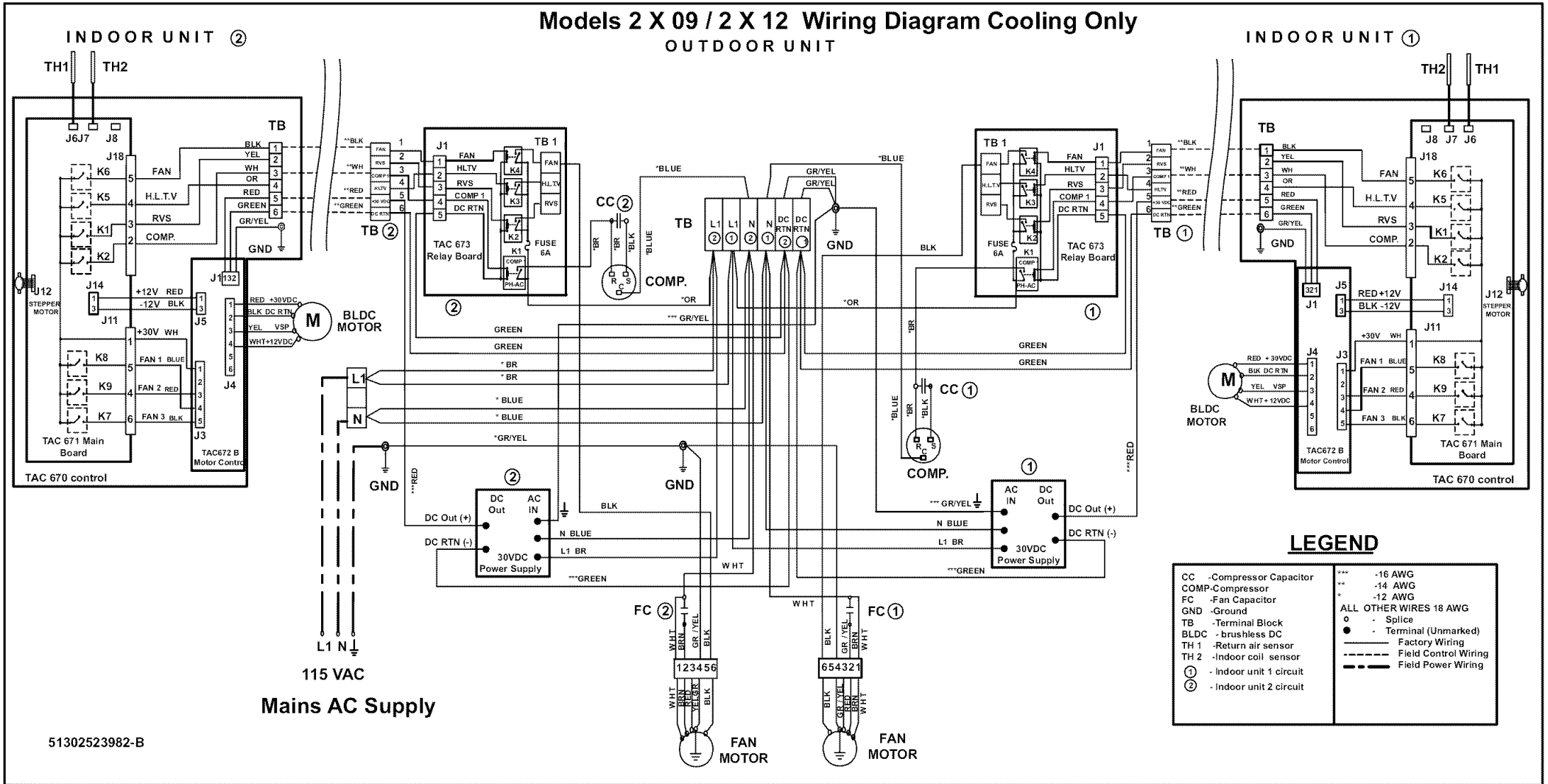

Fig. 14 System Wiring Schematic 40BNC009, 40BNC012 FAN COIL WITH 38BCC018, 38BCC024 Condensing Unit

START-UP

System Checks

1. Conceal the tubing where possible.
2. Make sure that the drainage tube slopes downward along its entire length.
3. Ensure all tubing and connections are properly insulated.
4. Fasten tubes to the outside wall.
5. Seal the hole through which the cables and tubing pass.
6. Connect the air conditioner to the power source and turn it on.
7. Check all air conditioner operating modes. Refer to Owner's Manual for operating details.

INDOOR UNIT

1. Do all the remote controller buttons function properly?
2. Do the display panel lights work properly?
3. Does the air deflection louver function properly?
4. Does the drainage work?

OUTDOOR UNIT

1. Are there unusual noises or vibrations during operation?
2. Is noise, drain water or airflow from the unit likely to disturb the neighbors?
3. Are there any gas leaks?

EXPLAIN THE FOLLOWING ITEMS TO THE CUSTOMER, WITH THE AID OF THE OWNER'S MANUAL:

1. How to turn the air conditioner on and off; selecting cooling, heating and other operating modes; setting a desired temperature; setting the timer to automatically start and stop air conditioner operation; and the other features of the remote controller and display panel.
2. How to remove and clean the air filter.
3. How to set the air deflection louver.
4. Explain care and maintenance.
5. Present the Owner's Manual and installation instructions to the customer.

CARE AND MAINTENANCE

The following may be performed by the equipment owner.

Outdoor Units

⚠ WARNING

Before performing recommended maintenance, be sure unit main power switch is turned off. Failure to do so may result in electric shock or injury from rotating fan blade.

CLEANING COILS — Coil should be washed out with water or blown out with compressed air. Clean coil annually or as required by location and outdoor air conditions. Inspect coil monthly and clean as required. Fins are not continuous through coil sections. Dirt and debris may pass through first section, become trapped between the row of fins and restrict outdoor unit airflow. Use a flashlight to determine if dirt or debris has collected between coil sections. Clean coil as follows:

1. Turn off unit power and install lockout tag.
2. Using a garden hose or other suitable equipment, flush coil from the outside to remove dirt. Be sure to flush all dirt and debris from drain holes in base of unit. Fan motors are waterproof.

Indoor Units

⚠ CAUTION

To avoid the possibility of electric shock, before performing any cleaning and maintenance operations, always turn off power to the system by pressing the ON/OFF button on the remote control and turn off the separate disconnect switch located near the unit.
If the indoor unit is on a separate switch, be sure to turn this disconnect off as well.

⚠ CAUTION

Do not wash filter in water over 120°F (to avoid shrinkage). Do not expose filter to fire (to avoid fire damage). Do not expose filter to direct sunlight. Clean filter more frequently when air is extremely dirty.

⚠ CAUTION

Do not attempt to clean or service components in controlbox.

To Clean the Indoor Unit Front Panel — if the front panel of the unit becomes dirty or smudged, wipe the out-side of the panel with a soft dry cloth. Use a mild liquid detergent and wipe off carefully with a dry cloth.

To Clean Indoor Coil — To clean the coil, remove indoor unit front panel and vacuum the coil fins, using care not to bend or damage fins.

LUBRICATION — The indoor-fan, automatic air sweep, and the outdoor-fan motors are factory lubricated and require no oiling.

Air Filters for Indoor Units

⚠ CAUTION

Operating your system with dirty air filters may damage the indoor unit and, in addition, can cause reduced performance, intermittent system operation, frost build up on the indoor coil, and blown fuses. Inspect and clean or replace the air filters monthly.

TO REMOVE AIR FILTERS — Open the unit's front panel by lifting the lower part and pulling it gently outward and upward.

Pull out the filters.

TO CLEAN OR REPLACE FILTERS — Filters can be vacuumed or washed in warm water. Shake filter to remove any excess water, and replace it back. If the filter has begun to break down or is torn, replace it. Replacement filters are available through a local dealer.

SERVICE

The following should be performed by a qualified service technician.

Clean Condensate Drains — Clean all drains and drain pans at the start of each cooling season. Check the flow by pouring water into the drain.

Clean or Replace Drain Pan — The drain pan should only be cleaned or replaced by a qualified service technician.

1. Place a plastic sheet on the floor to catch any water that may spill from the drain pan.
2. Remove the intake grille and distribution assembly.
3. Remove the condensate water in the drain pan by letting water drain into a 3-gallon bucket.

TROUBLESHOOTING (Tables 6-8, and Fig. 19)



WARNING

Be sure to check for broken wires or loose cable lugs before troubleshooting system.

Table 6 — Service Indicators

LAMP STATUS	INDICATION	CORRECTION ACTION
1 Flash	Faulty TH1 Sensor	Check the TH1 thermistor for correct resistance. Check for proper connection. Replace thermistor if necessary.
2 Flashes	Faulty TH2 Sensor	Check the TH2 thermistor for correct resistance. Check for proper connection. Replace thermistor if necessary.
3 Flashes	Low Pressure	Check system pressures. Check refrigerant charge. Check thermistors (TH1 and TH2) for correct resistance.
4 Flashes	High Pressure	Check system pressures. Check refrigerant charge. Check thermistors (TH1 and TH2) for correct resistance.
5 Flashes	Low Voltage	Check operating voltage. Check electrical connections.
6 Flashes	High Voltage	Check operating voltage. Check electrical connections.

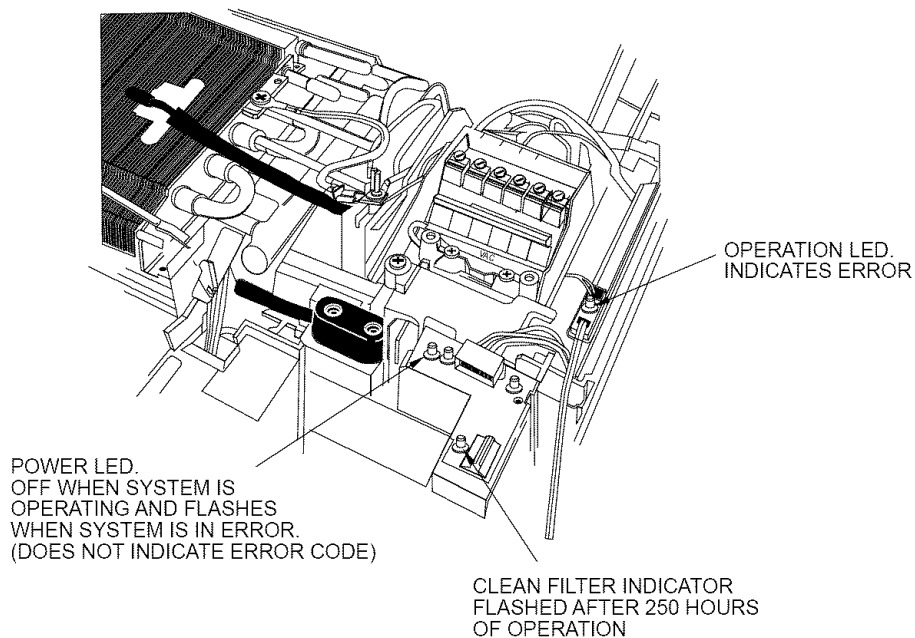

Fig. 19— Indicator Lights

Table 7 -BCC/BCQ Thermistor TH-1, TH-2, and TH-3 Temperature to Resistance Conversion

TEMPERATURE (°F)	TEMPERATURE (°C)	TEMPERATURE TOLERANCE (°F)	TEMPERATURE TOLERANCE (°C)	MINIMUM RESISTANCE (KΩ)	MEAN RESISTANCE (KΩ)	MAXIMUM RESISTANCE (KΩ)
-4.0	-20	±2.0	±1.1	30.89	32.44	34.05
-2.2	-19	±2.0	±1.1	29.46	30.93	32.45
-0.4	-18	±2.0	±1.1	28.12	29.51	30.94
1.4	-17	±2.0	±1.1	26.84	28.16	29.51
3.2	-16	±2.0	±1.1	25.64	26.88	28.15
5.0	-15	±2.0	±1.1	24.49	25.66	26.87
6.8	-14	±2.0	±1.1	23.40	24.52	25.66
8.6	-13	±2.0	±1.1	22.38	23.43	24.50
10.4	-12	±2.0	±1.1	21.40	22.39	23.41
12.2	-11	±2.0	±1.1	20.47	21.41	22.38
14.0	-10	±1.8	±1.0	19.59	20.48	21.40
15.8	-9	±1.8	±1.0	18.74	19.59	20.45
17.6	-8	±1.8	±1.0	17.94	18.74	19.56
19.4	-7	±1.8	±1.0	17.17	17.93	18.71
21.2	-6	±1.8	±1.0	16.44	17.16	17.90
23.0	-5	±1.8	±1.0	15.75	16.43	17.13
24.8	-4	±1.8	±1.0	15.10	15.74	16.40
26.6	-3	±1.8	±1.0	14.47	15.08	15.71
28.4	-2	±1.8	±1.0	13.87	14.46	15.05
30.2	-1	±1.8	±1.0	13.31	13.86	14.42
32.0	0	±1.8	±1.0	12.77	13.29	13.83
33.8	1	±1.8	±1.0	12.25	12.74	13.25
35.6	2	±1.8	±1.0	11.75	12.22	12.70
37.4	3	±1.8	±1.0	11.28	11.73	12.18
39.2	4	±1.8	±1.0	10.83	11.25	11.68
41.0	5	±1.8	±1.0	10.40	10.80	11.21
42.8	6	±1.8	±1.0	9.986	10.370	10.76
44.6	7	±1.8	±1.0	9.595	9.960	10.33
46.4	8	±1.8	±1.0	9.222	9.569	9.921
48.2	9	±1.8	±1.0	8.866	9.196	9.530
50.0	10	±1.8	±1.0	8.526	8.840	9.157
51.8	11	±1.8	±1.0	8.197	8.496	8.797
53.6	12	±1.8	±1.0	7.883	8.167	8.453
55.4	13	±1.6	±0.9	7.583	7.853	8.125
57.2	14	±1.6	±0.9	7.296	7.553	7.812
59.0	15	±1.6	±0.9	7.022	7.267	7.513
60.8	16	±1.6	±0.9	6.761	6.993	7.227
62.6	17	±1.6	±0.9	6.510	6.731	6.954
64.4	18	±1.6	±0.9	6.271	6.481	6.693
66.2	19	±1.6	±0.9	6.042	6.242	6.444
68.0	20	±1.6	±0.9	5.822	6.013	6.205
69.8	21	±1.6	±0.9	5.611	5.793	5.975
71.6	22	±1.6	±0.9	5.408	5.581	5.755
73.4	23	±1.6	±0.9	5.214	5.379	5.544
75.2	24	±1.6	±0.9	5.028	5.185	5.343
77.0	25	±1.6	±0.9	4.850	5.000	5.150
78.8	26	±1.6	±0.9	4.675	4.821	4.968
80.6	27	±1.6	±0.9	4.508	4.650	4.793
82.4	28	±1.6	±0.9	4.347	4.486	4.626
84.2	29	±1.8	±1.0	4.193	4.329	4.466
86.0	30	±1.8	±1.0	4.046	4.179	4.312
87.8	31	±1.8	±1.0	3.904	4.033	4.163
89.6	32	±1.8	±1.0	3.767	3.894	4.020
91.4	33	±1.8	±1.0	3.637	3.760	3.884
93.2	34	±1.8	±1.0	3.511	3.631	3.752
95.0	35	±1.8	±1.0	3.391	3.508	3.626
96.8	36	±2.0	±1.1	3.275	3.390	3.505
98.6	37	±2.0	±1.1	3.164	3.276	3.389

NOTE: Resistance tolerance ± 3%.

Table 7 -BCC/BCQ Thermistor TH-1, TH-2, and TH-3 Temperature to Resistance Conversion (Cont.)

TEMPEATURE (°F)	TEMPERATURE (°C)	TEMPERATURE TOLERANCE (°F)	TEMPERATURE TOLERANCE (°C)	MINIMUM RESISTANCE (KΩ)	MEAN RESISTANCE (KΩ)	MAXIMUM RESISTANCE (KΩ)
100.4	38	±2.0	±1.1	3.058	3.167	3.277
102.2	39	±2.0	±1.1	2.956	3.062	3.169
104.0	40	±2.0	±1.1	2.857	2.961	3.066
105.8	41	±2.0	±1.1	2.762	2.864	2.966
107.6	42	±2.0	±1.1	2.671	2.770	2.870
109.4	43	±2.2	±1.2	2.583	2.679	2.777
111.2	44	±2.2	±1.2	2.498	2.593	2.688
113.0	45	±2.2	±1.2	2.417	2.509	2.602
114.8	46	±2.2	±1.2	2.339	2.429	2.520
116.6	47	±2.2	±1.2	2.264	2.352	2.441
118.4	48	±2.3	±1.3	2.192	2.227	2.364
120.2	49	±2.3	±1.3	2.122	2.206	2.291
122.0	50	±2.3	±1.3	2.055	2.137	2.220
123.8	51	±2.3	±1.3	1.990	2.070	2.151
125.6	52	±2.3	±1.3	1.928	2.006	2.085
127.4	53	±2.3	±1.3	1.867	1.943	2.021
129.2	54	±2.3	±1.3	1.809	1.883	1.959
131.0	55	±2.5	±1.4	1.753	1.826	1.900
132.8	56	±2.5	±1.4	1.699	1.770	1.842
134.6	57	±2.5	±1.4	1.647	1.717	1.787
136.4	58	±2.5	±1.4	1.597	1.665	1.734
138.2	59	±2.5	±1.4	1.549	1.615	1.683
140.0	60	±2.5	±1.4	1.503	1.567	1.633
141.8	61	±2.7	±1.5	1.458	1.521	1.585
143.6	62	±2.7	±1.5	1.414	1.476	1.539
145.4	63	±2.7	±1.5	1.372	1.432	1.494
147.2	64	±2.7	±1.5	1.332	1.391	1.451
149.0	65	±2.7	±1.5	1.293	1.350	1.409
150.8	66	±2.9	±1.6	1.255	1.311	1.369
152.6	67	±2.9	±1.6	1.219	1.274	1.330
154.4	68	±2.9	±1.6	1.184	1.237	1.292
156.2	69	±2.9	±1.6	1.150	1.202	1.256
158.0	70	±2.9	±1.6	1.117	1.168	1.221

NOTE: Resistance tolerance ± 3%.

Table 8 — General System Troubleshooting Guide

SYMPTOM	PROBABLE CAUSE	CORRECTIVE ACTION
Unit Fails to Start.	Power supply from outdoor unit to indoor unit is not connected. Power supply to unit not connected (POWER LED Off).	Check for proper connection of power at disconnect.
	Fuse blown (POWER LED Off).	Reset circuit breaker or replace line fuse.
	ON/SEND button has not been pressed.	Press ON/SEND button on remote control.
	Indoor unit does not receive transmitted commands.	Make sure that nothing is blocking the remote control transmission to the unit.
Only Indoor Fan Works when Cooling or Heating is Desired. NOTE: Indoor fan runs continuously in cooling mode.	The selected mode is Fan Only, or Cool when heating is desired.	Check if the remote control is in the desired mode. If not, select the correct mode (refer to User manual). Also note that every 15 minutes (maximum) the compressor will be switched minimally on for 3 minutes.
	Temperature is set to a value which is too high (in Cool mode).	Observe the temperature setting on the remote control. Also note that each 15 minutes (maximum), the compressor will be switched on minimally for 3 minutes.
Only Indoor Fan Motor and Outdoor Fan Motor are Working. No Cooling and/or Heating Takes Place.	Overload safety device on compressor is cut out due to high temperature.	Switch off power and try again after one hour.
	Compressor run capacitor is burnt.	Replace compressor run capacitor.
	Compressor winding shorted.	Replace compressor.
No Air Supply at Indoor Unit (Compressor Operates).	Indoor fan motor is blocked or turns slowly.	1. Check voltage. Repair wiring if necessary. 2. Check indoor fan wheel if tight on motor shaft. Tighten if necessary.
	Indoor fan motor capacitor is burnt.	Replace indoor fan motor capacitor.
	Indoor fan motor winding is burnt.	Replace indoor fan motor.
	In Heat mode: Delayed start for indoor fan motor.	Normal software delay (maximum of 20 sec).
	Clogged air filters.	Clean filters.
Low Capacity.	Lack of refrigerant. Ice formation on the evaporator coil. gas leak.	Unit must be charged (according to the nameplate) after localizing the
	Clogged air filters.	Clean filters.
In Heat Mode, Only Compressor Runs. Outdoor and Indoor Fan Motors are Stopped.	A/C operating in defrost cycle.	Wait 10 minutes (maximum) until the unit resumes normal operation.
Water Accumulates and Overflows from Evaporator Drain Pan.	Drain pan pipe or hose is clogged or the spout of drain pan is clogged.	Disassemble plastic drain pipe from spout of evaporator drain pan. Flush with clean water.
Unit Does Not Operate in Desired Mode.	The unit is in the Auto, (emergency) mode.	Push button once to cancel Auto, (emergency) mode.
	Faulty remote control settings.	1. If remote control symbols respond to the commands correctly, check the unit ID Code (Standard or Alternative). Refer to "Changing Unit ID Code" in the Owner's Manual. 2. If Cool commands are OK, but Heat symbol is skipped on LCD, refer to setting the remote to cooling or heat pump on the Owner's Manual. 3. Replace remote control.
	Remote control low battery.	Replace remote control batteries.
The Unit Receives Interference from Other Remote Control or the Remote Control Interferes with Other Instruments.	Common Infrared Code.	Modify the Remote Control IR transmission code. Refer to "Changing Unit ID Code" in the Owner's Manual.

IMPORTANT:

The units are designed to work in heat mode only down to -10°C (14°F) outdoor ambient temperature.

If at starting time outdoor temperature is equal or lower than -10°C (14°F) the unit will not start and the filter led will flash five (5) times to indicate that low temperature protection is activated.