

Panasonic®

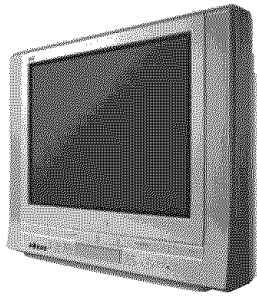

TV / DVD-RAM / VCR Combination Operating Instructions

Omnivision **VHS**

Model No. **PV-DR2714**

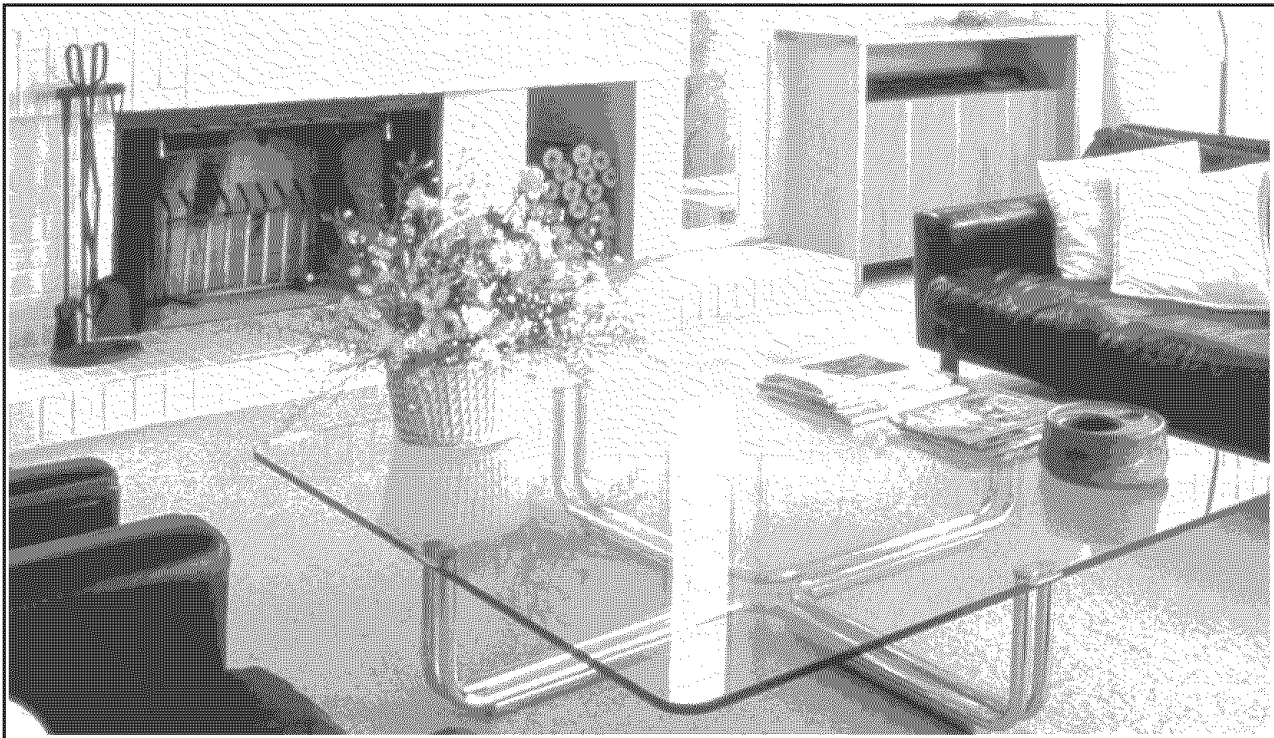

• Initial Setup and Connection Procedures are on page 16.



MULTI FORMAT PLAYBACK

DVD-RAM
DVD-R
video playback

CD-R/RW
playback

MP3
PLAYBACK

*Ability to play back may depend on recording conditions.



As an **ENERGY STAR®** Partner, Matsushita Electric Corporation of America has determined that this product or product model meets the **ENERGY STAR®** guidelines for energy efficiency.



Please read these instructions carefully before attempting to connect, operate, or adjust this product. Please save this manual.
Spanish Quick Use Guide is included.
(Guía para rápida consulta en español está incluida.)

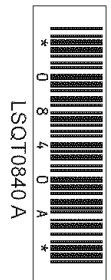

Getting Started

TV Operation

VCR
Operation

TV/VCR
Operation

Disc Operation

Dubbing
Operation

Information

Before Using

Congratulations

On your purchase of one of the most sophisticated and reliable products on the market today. Used properly, it will bring you and your family years of enjoyment. Please fill in the information below. The serial number is on the tag located on the back of your unit.

Date of Purchase _____

Dealer Purchased From _____

Dealer Address _____

Dealer Phone No. _____

Model No. _____

Serial No. _____

Apparatus Claims of U.S. Patent Nos. 4,631,603, 4,577,216, 4,819,098, and 4,907,093, licensed for limited viewing uses only.

This product incorporates copyright protection technology that is protected by method claims of certain U.S. Patents and other intellectual property rights owned by Macrovision Corporation and other rights owners. Use of this copyright protection technology must be authorized by Macrovision Corporation, and is intended for home and other limited viewing uses only unless otherwise authorized by Macrovision Corporation. Reverse engineering or disassembly is prohibited.

This television receiver provides display of television closed captioning.

Accessories

Please check and identify the supplied accessories. Use numbers indicated in parentheses when asking for replacement parts.

To order accessories, call toll free 1-800-332-5368.

1 Remote Control (EUR7624050)

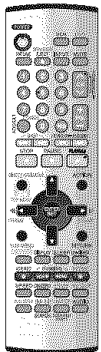

2 Batteries "AA"



Safety Precaution

Be sure to read the following cautions carefully.

▲ WARNING

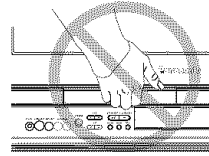

Never pick unit up by VCR cassette opening.

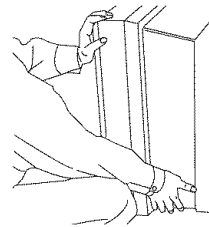

Always grasp bottom and front of unit as shown for proper balance.

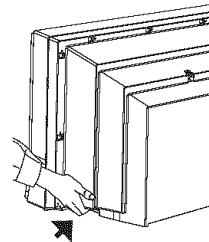

To avoid injury to hands, always hold unit by area shown with arrow when resting it on a flat surface.

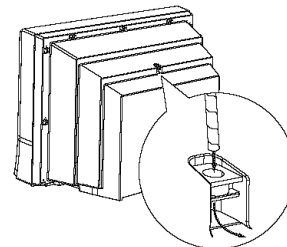

The unit may tip or fall if not situated on a stable surface, if pushed, or during an earthquake. Use a strong rope or chain (not included) to fasten the unit firmly to a strong wall support.

Safety Precautions/Mesures de sécurité

WARNING

TO PREVENT FIRE OR SHOCK HAZARD, DO NOT EXPOSE THIS EQUIPMENT TO RAIN OR MOISTURE.

CAUTION

TO PREVENT ELECTRIC SHOCK, MATCH WIDE BLADE OF PLUG TO WIDE SLOT IN WALL SOCKET. FULLY INSERT.

AVERTISSEMENT :

AFIN DE PRÉVENIR TOUT RISQUE D'INCENDIE OU DE CHOCS ÉLECTRIQUES, NE PAS EXPOSER CET APPAREIL À LA PLUIE OU À UNE HUMIDITÉ EXCESSIVE.

Attention :

POUR ÉVITER LES CHOCS ÉLECTRIQUES, INTRODUIRE LA LAME LA PLUS LARGE DE LA FICHE DANS LA BORNE CORRESPONDANTE DE LA PRISE ET POUSSER JUSQU'AU FOND.

FCC WARNING :

ANY UNAUTHORIZED CHANGES OR MODIFICATIONS TO THIS EQUIPMENT WOULD VOID THE USER'S AUTHORITY TO OPERATE.

FCC NOTICE:

This equipment has been tested and found to comply with part 15 of the FCC Rules. These limits are designed to provide reasonable protection against harmful interference when operated in a residential environment. If this equipment does cause interference to radio or television reception, which can be determined by turning the equipment off and on, use the equipment in another location and/or utilize an electrical outlet different from that used by the receiver. If necessary, consult the dealer or an experienced radio/TV technician for help. You may find the booklet, "Something About Interference" available from FCC local regional offices helpful.

This product utilizes both a Cathode Ray Tube (CRT) and other components that contain lead. Disposal of these materials may be regulated in your community due to environmental considerations. For disposal or recycling information please contact your local authorities, or the Electronics Industries Alliance: <<http://www.eiae.org>>

This video recorder, equipped with the HQ (High Quality) System, is compatible with existing VHS equipment. Only use those tapes with the  mark. It is recommended that only cassette tapes that have been tested and inspected for use in 2, 4, 6, and 8 hour VCR machines be used. This television receiver provides display of television closed captioning in accordance with §15.119 of the FCC rules.

CAUTION:

UNIT IS A CLASS I LASER PRODUCT.
HOWEVER THIS UNIT USES A VISIBLE LASER BEAM WHICH COULD CAUSE HAZARDOUS RADIATION EXPOSURE IF DIRECTED. BE SURE TO OPERATE THE UNIT CORRECTLY AS INSTRUCTED.
WHEN THIS UNIT IS PLUGGED TO THE WALL OUTLET, DO NOT PLACE YOUR EYES CLOSE TO THE OPENING OF THE DISC TRAY AND OTHER OPENINGS TO LOOK INTO THE INSIDE OF THIS UNIT.
USE OF CONTROLS OR ADJUSTMENTS OR PERFORMANCE OF PROCEDURES OTHER THAN THOSE SPECIFIED HEREIN MAY RESULT IN HAZARDOUS RADIATION EXPOSURE.
DO NOT OPEN COVERS AND DO NOT ATTEMPT TO REPAIR THE UNIT YOURSELF. REFER SERVICING TO QUALIFIED PERSONNEL.

CAUTION:

LASER RADIATION WHEN OPEN.
DO NOT STARE INTO BEAM.

ATTENTION:

RAYONNEMENT LASER EN CAS D'OUVERTURE.
NE PAS REGARDER DANS LE FAISCEAU.

(Inside of product)

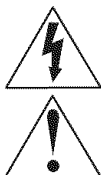

This symbol warns the user that uninsulated voltage within the unit may have sufficient magnitude to cause electric shock. Therefore, it is dangerous to make any kind of contact with any inside part of this unit.

This symbol alerts the user that important literature concerning the operation and maintenance of this unit has been included. Therefore, it should be read carefully in order to avoid any problems.

IMPORTANT SAFEGUARDS AND PRECAUTIONS

⚠ WARNING

TO REDUCE THE RISK OF ELECTRIC SHOCK, FIRE, INJURY TO PERSONS OR DAMAGE TO THIS PRODUCT, READ AND RETAIN ALL SAFETY AND OPERATING INSTRUCTIONS. HEED ALL WARNINGS IN THE MANUAL AND ON THE PRODUCT.

■ INSTALLATION

1 POWER SOURCE CAUTION

Operate only from power source indicated on unit or in this manual. If uncertain, have your Electric Utility Service Company or Video Products Dealer verify your home power source.

2 POWER CORD PLUG

For safety, this unit has a polarized type plug (one wide blade), or a three-wire grounding type plug. Always hold the plug firmly and make sure your hands are dry when plugging in or unplugging the AC power cord. Regularly remove dust, dirt, etc. on the plug.

POLARIZED PLUG CAUTION:

The plug fits into outlet only one way. If it cannot be fully inserted, try reversing it. If it still will not fit, have an electrician install the proper wall outlet. Do not tamper with the plug.

GROUNDING PLUG CAUTION:

The plug requires a three-hole grounding outlet. If necessary, have an electrician install the proper outlet. Do not tamper with the plug.

3 POWER CORD

To avoid unit malfunction, and to protect against electrical shock, fire or personal injury:

- Keep power cord away from heating appliances and walking traffic. Do not rest heavy objects on, or roll such objects over the power cord.
- Do not tamper with the cord in any way.
- An extension cord should have the same type plug (polarized or grounding) and must be securely connected.
- Overloaded wall outlets or extension cords are fire hazards.
- Frayed cords, damaged plugs, and damaged or cracked wire insulation are hazardous and should be replaced by a qualified electrician.

4 DO NOT BLOCK VENTILATION HOLES

Ventilation openings in the cabinet release heat generated during operation. If blocked, heat build-up may result in a fire hazard or heat damage to cassettes or discs.

For your protection:

- a. Never cover ventilation slots while unit is ON, or operate unit while placed on a bed, sofa, rug, or other soft surface.
- b. Avoid built-in installation, such as a book case or rack, unless properly ventilated.

5 AVOID EXTREMELY HOT LOCATIONS OR SUDDEN TEMPERATURE CHANGES

Do not place unit over or near a heater or radiator, in direct sunlight, inside closed vehicles, in high temperature locations [over 95 °F (35 °C)], or in over 75 % humidity. If unit is suddenly moved from a cold place to a warm one, moisture may condense in unit and on the tape causing damage. Never subject unit to vibration, impact, or place it so that the surface is tilted as internal parts may be seriously damaged.

6 TO AVOID PERSONAL INJURY

- Never place unit on support or stand that is not firm, level, and adequately strong. The unit could fall causing serious injury to a child or adult and damage to the unit.
- Move any appliance and cart combination with care. Quick stops, excessive force, and uneven surfaces may cause objects to overturn.
- Carefully follow all operating instructions.



■ SERVICE

1 DO NOT SERVICE PRODUCT YOURSELF

If, after carefully following detailed operating instructions, the unit does not operate properly, do not attempt to open or remove covers, or make any adjustments not described in the manual. Unplug unit and contact a qualified service technician.

2 REPLACEMENT OF PARTS

Make sure the service technician uses only parts specified by the manufacturer, or have equal safety characteristics as original parts. The use of unauthorized substitutes may result in fire, electric shock, or other hazards.

3 SAFETY CHECK AFTER SERVICING

After unit is serviced or repaired, request that a thorough safety check be done as described in the manufacturer's service literature to ensure video unit is in safe operating condition.

■ USING THE UNIT

Before unit is brought out of storage or moved to a new location, refer again to the INSTALLATION section of these safeguards.

1 KEEP UNIT WELL AWAY FROM WATER OR MOISTURE, such as vases, sinks, tubs, etc.

2 IF EXPOSED TO RAIN, MOISTURE, OR STRONG IMPACT, unplug unit and have it inspected by a qualified service technician before use.

3 ELECTRICAL STORMS

During a lightning storm, or before leaving unit unused for extended periods of time, disconnect all equipment from the power source as well as the antenna and cable system.

4 WHEN UNIT IS PLUGGED IN

• DO NOT OPERATE IF:

- liquid has spilled into unit.
 - unit was dropped or otherwise damaged.
 - unit emits smoke, odours, or noises. Immediately unplug unit, and have it inspected by a service technician to avoid potential fire and shock hazards.
- Never drop or push any object through openings in unit. Touching internal parts may cause electric shock or fire hazard. Do not put any foreign object on the tray.
- Keep magnetic objects, such as speakers, away from unit to avoid electrical interference.

5 USING ACCESSORIES

Use only accessories recommended by the manufacturer to avoid risk of fire, shock, or other hazards.

6 CLEANING UNIT

Unplug unit. Use a clean, dry, chemically untreated cloth to gently remove dust or debris. DO NOT USE cleaning fluids, aerosols, or forced air that could over-spray, or seep into unit and cause electrical shock. Any substance, such as wax, adhesive tape, etc. may mar the cabinet surface. Exposure to greasy, humid, or dusty areas may adversely affect internal parts.

■ OUTDOOR ANTENNA INSTALLATION

1 SAFE ANTENNA AND CABLE CONNECTION

An outside antenna or cable system must be properly grounded to provide some protection against built up static charges and voltage. Section 810 of the National Electrical Code, ANSI/NFPA 70 (in Canada, part 1 of the Canadian Electrical Code) provides information regarding proper grounding of the mast and supporting structure, grounding of the lead-in wire to an antenna discharge unit, size of grounding conductors, location of antenna discharge unit, connection to grounding electrodes, and requirements for the grounding electrode.

2 KEEP ANTENNA CLEAR OF HIGH VOLTAGE POWER LINES OR CIRCUITS

Locate an outside antenna system well away from power lines and electric light or power circuits so it will never touch these power sources should it ever fall. When installing antenna, absolutely never touch power lines, circuits or other power sources as this could be fatal.

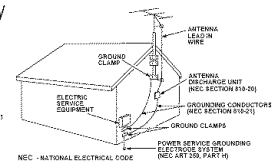

NEC - NATIONAL ELECTRICAL CODE

Table of Contents

Getting Started

Before Using	2
Safety Precautions/Mesures de sécurité	3
IMPORTANT SAFEGUARDS AND PRECAUTIONS	4
Information	6
Location of Controls	9
Connections	12

TV Operation

Tuning TV	16
TV Operation	20
MTS Broadcast / TV Stereo System	21
TV Timer Features	22
Closed Caption System	23
Video / Audio Setting	25

VCR Operation

Before using the VCR	28
Recording Television Programs	29
Timer Recording	30
Playing VCR	32

TV / VCR Operation

V-Chip Control Features	35
Display Feature	39

Disc Operation

Before using the Disc	40
DVD Functions Windows and Status Messages	41
Function List	42
Recording Television Programs	44
Timer Recording	46
Various Recording	48
Playing Discs	50
Various PlayBack	51
Using On-Screen Menus	55
Editing the Recorded Programs (Using the Direct Navigator)	57
Using Play List	60
Disc Setting	63
Entering Text	66
Changing the Unit's Settings	67

Dubbing Operation

Transfer (Dubbing) from DVD	70
Transfer (Dubbing) from Tape	72

Information

Glossary	74
Error Messages	75
Before Requesting Service	76
Q & A	78
Specifications	79
Limited Warranty	80
Customer Services Directory	81
Guía rápida de uso en español	82
Index	90

Getting Started

TV Operation

VCR Operation

TV/VCR Operation

Disc Operation

Dubbing Operation

Information

Information

Information (Unit, Cassette)

Loading the Batteries

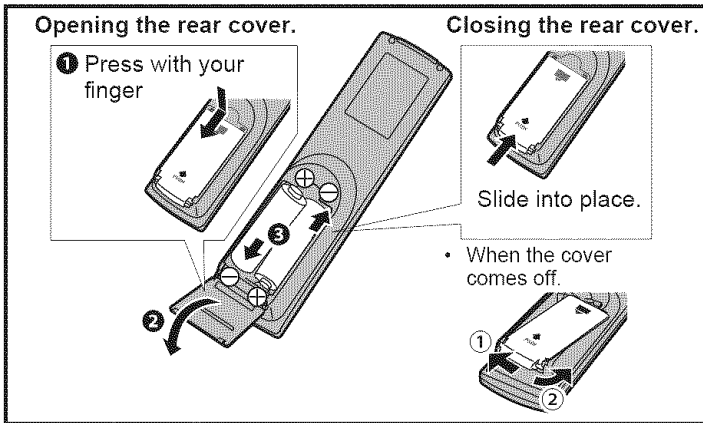

- Insert so the poles (+ and -) match those in the Remote Control.
- Do not use rechargeable type batteries.

Do not:

- Mix old and new batteries.
- Use different types at the same time.
- Heat or expose to flame.
- Take apart or short circuit.
- Attempt to recharge alkaline or manganese batteries.
- Use batteries if the covering has been peeled off.

Mishandling of batteries can cause electrolyte leakage which can damage items the fluid contacts and may cause a fire. Remove if the Remote Control is not going to be used for a long period of time. Store in a cool, dark place.

Prevent Accidental Tape Erasure

■ Break off the tab to protect.

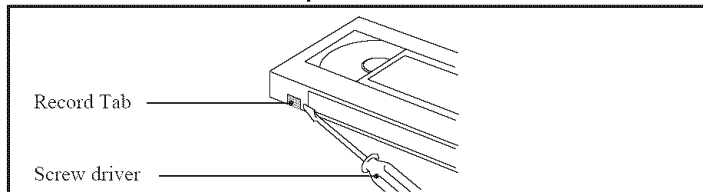

■ To record again.

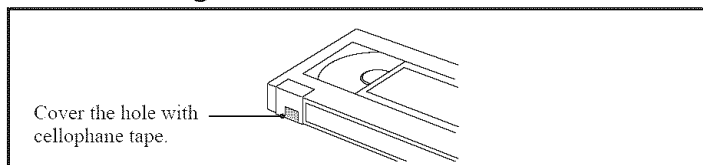

DST (Daylight Saving Time)

Unit auto adjusts clock for DST (Daylight Saving Time.)

■ Spring (First Sunday in April)

DST: ON → Sets clock ahead one hour.

■ Autumn (Last Sunday in October)

DST: ON → Turns clock back one hour.

- If your area does not observe Daylight Saving Time, select DST : OFF (see "Manual Clock Setting" on page 17).
- Keep these time changes in mind when programming the unit for timer recording.

Head Cleaning

Playing older or damaged tapes may eventually cause video heads to become clogged.

■ Head Clog Sensor

During playback this screen appears if clogging is detected. To clear message from screen, press PLAY on the Remote Control or unit.

VIDEO HEADS MAY
NEED CLEANING
PLEASE INSERT HEAD
CLEANING CASSETTE
OR REFER TO MANUAL

END:PLAY

- Use "dry" type head cleaning cassette only. (Part No. NV-TCL30PT is recommended.)
- Follow cleaning tape directions carefully. Excessive use of head cleaning tape can shorten the video head life.

Information (Disc)

Play-only discs

Disc type	Disc Logo	Instructions	Indication in these operating instructions
DVD-Video		High quality movie and music discs	DVD-V
CD		Music and audio recorded (including CD-R/RW) CD-R and CD-RW with music recorded in MP3 (p. 53)	CD (CD-DA) or MP3 (MP3)

- The producer of the material can control how DVD-Video is played. This means that you may not be able to control play of a disc with some operations described in these operating instructions. Read the disc's instructions carefully.
- This unit can play CD-R/CD-RW (audio recording disc) recorded with CD-DA (digital audio), or MP3. Finalize* the disc after recording.
* A process that allows play on compatible equipment.
- This unit cannot record onto CD-R or CD-RW.

■ Discs that cannot be played

- 2.6 and 5.2 GB DVD-RAM, 12 cm (5")
- 3.95 and 4.7 GB DVD-R for Authoring
- Unfinalized DVD-R recorded on other equipment ("Finalize" on page 74)
- PAL discs
- DVD with Region No. other than "1" or "ALL", DVD from PAL system, DVD-ROM, DVD+R, DVD-AUDIO, DVD-RW, DVD+RW, CD-ROM, CDV, CVD, CD-G, CD-TEXT, SACD, Photo-CD, Video CD.

■ DVD-Video

You can play discs with these symbols.



	Dolby Digital: This unit can play Dolby Digital in stereo (2 channels). Connect an amplifier with a built-in Dolby Digital decoder to enjoy surround sound.
	DTS Digital Surround: Connect this unit to equipment that has a DTS decoder to enjoy DVDs with this mark.

■ CD-R and CD-RW discs

This unit can play finalized* CD-R/CD-RW (audio recording disc) recorded in CD-DA (digital audio), MP3 format. Some CD-R or CD-RW may not be played due to the condition of the recording.

* A process that allows play on compatible equipment.

Discs you can use for recording and play

Disc type	Disc Logo	Indication in these operating instructions
DVD-R		DVD-R
DVD-RAM		RAM

Notes:

- We recommend using Panasonic discs. DVD-R from other manufacturers may not be recorded or played due to the condition of the recording.
- This unit cannot record to discs containing both PAL and NTSC signals. Play of discs recorded with both PAL and NTSC on another unit is not guaranteed.
- Some parts of the disc, for example where one program ends and another begins, may not play smoothly.
- MP3 recordings on a DVD-RAM cannot be played back.

■ DVD-RAM discs

Re-writable discs

- You can record up to 16 hours [in EP (8 Hour) mode on double-sided disc. You cannot record or play continuously on two sides.] ("Recording modes and approximate recording times" on page 45.)
- You can perform chasing playback (p. 48).
- Scratch and dust resistant cartridge discs and large capacity double sided discs (9.4 GB) are commercially available.
- You can record digital broadcasts that allow "One time only recording" when using CPRM (Content Protection for Recordable Media) compatible discs (p. 74).

Capacity	<ul style="list-style-type: none"> • 12 cm (5") 9.4 GB (double-sided) and 4.7 GB (single-sided) • 8 cm (3") 2.8 GB (double-sided)
----------	---

Protection (Cartridge discs)

With the write-protect tab in the protect position, you cannot record to, edit, or erase from the disc.
Play automatically starts when inserted in the unit.

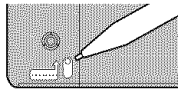

■ DVD-R discs

One time recording discs (recordable until the disc is full)

- You can record up to 8 hours [in EP (8 Hour) mode].
- **By finalizing the disc, you can play it in a DVD player as DVD-Video (Play only) (pp. 65, 74).**
- You cannot record digital broadcasts that allow "One time only recording".
- This unit is compatible with 1x-4x recording speed discs.

Capacity	<ul style="list-style-type: none"> • 12 cm (5") 4.7 GB, 8 cm (3") 1.4 GB for General Ver. 2.0 • 4.7 GB, 12 cm (5") for General Ver. 2.0 / 4x - SPEED DVD-R Revision 1.0
----------	---

Discs you can use

Type		Possible operations*1				
		A	B	C	D	E
DVD-RAM	RAM	○	○	○	○	○
DVD-R	Before Finalizing DVD-R	○	○	○*2	×	×
	After Finalizing DVD-V	×	○	×	×	×
DVD-Video	DVD-V	×	○	×	×	○
CD	CD-DA Format CD	×	○	×	×	×
	MP3 Format MP3	×	○	×	×	×

*1. Possible operations (O : able, X : unable)

- A:** Recording
- B:** Playback
- C:** Title erase/Entering text
- D:** Creating play lists
- E:** Selecting audio

*2. The remaining capacity of the disc will not be increased even if erased.

Disc Composition Examples

Disc type		Disc Composition
DVD-RAM	RAM	<p>Title (Program) Title 1 (Program 1) Title 2 (Program 2) Title 3 (Program 3) Title 4 (Program 4) Title 5 (Program 5)</p> <p>PlayList: Chapter 1 (Scene 1) Chapter 2 (Scene 2) Chapter 3 (Scene 3) Chapter 4 (Scene 4) Chapter 5 (Scene 5)</p> <p>Note:</p> <ul style="list-style-type: none"> • You can create chapters for your recorded title/program. And, you can arrange created chapters into a desired scene list (Play List).
DVD-R	Before Finalizing DVD-R	Title (Program) Title 1 (Program 1) Title 2 (Program 2) Title 3 (Program 3) Title 4 (Program 4) Title 5 (Program 5)
	After Finalizing DVD-V	Title Chapter: Chapter 1 Chapter 2 Chapter 3 Chapter 4 Chapter 5
DVD-Video	DVD-V	Title Chapter: Chapter 1 Chapter 2 Chapter 3 Chapter 4 Chapter 5
CD	CD-DA Format CD	Track: Track 1 Track 2 Track 3 Track 4 Track 5
	MP3 Format MP3	Group Track Total Track: Group 1 (1, 2, 3) Group 2 (1, 2, 3)

Which should I use, DVD-RAM or DVD-R?

The following chart indicates the differences. Select based upon what you require.

	DVD-RAM	DVD-R
Re-writable	YES	NO
Edit	YES	YES *1
Play on other players	YES *2	YES *3
Recording broadcasts that allow one copy	YES *5	NO

*1 You can erase, enter name and change thumbnail. Available space does not increase after erasing.

*2 Only on DVD-RAM compatible players.

*3 After finalizing the disc (pp. 65, 74).

*5 CPRM (p. 74) compatible discs only.

Region Management Information

This unit is designed and manufactured to respond to the Region Management Information that is recorded on a DVD disc. If the Region number described on the DVD disc does not correspond to the Region number of this unit, this unit cannot play this disc.

For U.S.A. and Canada

- The region number of this player is "1".
- The player will play DVD-Video marked with labels bearing "1" or "ALL".

Example:



MP3

■ Tips for making MP3 discs

- Discs must conform to ISO9660 level 1 or 2 (except for extended formats).
- Compatible compression rate: between 32 kbps and 320 kbps
- Compatible sampling rate: 16 kHz, 22.05 kHz, 24 kHz, 32 kHz, 44.1 kHz and 48 kHz
- Maximum number of tracks and groups recognizable: 999 tracks and 99 groups
- This unit is compatible with multi-session.
- This unit is not compatible with ID3 tags or packet writing.
- Depending on the recording, some items may not be playable.
- Reading or play of the disc may take time if there are a lot of sessions.
- The display order may differ from how the order is displayed on a computer.

■ Naming folders and files

- MP3 files must have the extension ".MP3" or ".mp3".
- At the time of recording, give folder and file names a 3-digit numeric prefix in the order you want them to play (this may not work at times).
- English alphabets and Arabic numerals are displayed correctly. Other characters may not be displayed correctly.

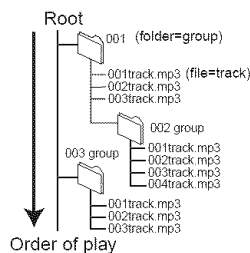

MPEG Layer-3 audio decoding technology licensed from Fraunhofer IIS and Thomson multimedia.

MP3
PLAYBACK

Maintenance

The precision parts in this unit are readily affected by the environment, especially temperature, humidity, and dust. Cigarette smoke also can cause malfunction or breakdown.

To clean this unit, wipe with a soft, dry cloth.

- Never use alcohol, paint thinner or benzine to clean this unit.
- Before using chemically treated cloth, read the instructions for the cloth carefully.

Observe the following points to ensure continued listening and viewing pleasure.

Dust and dirt may adhere to the unit's lenses over time, possibly making it impossible to record or play discs.

Use the recommended DVD-RAM/PD Lens cleaner (LF-K123LCA1) about once every year, depending on frequency of use and the operating environment.

Read the lens cleaner's instructions carefully before use.

Disc Handling

■ How to hold a disc

Do not touch the recorded surface.

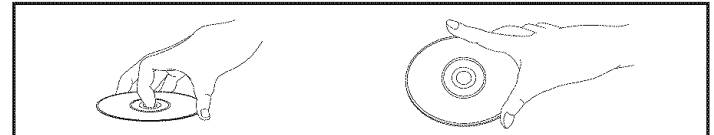

■ If there is dirt or condensation on the disc

- RAM DVD-R**
 - Clean with an optional DVD-RAM/PD Disc cleaner (LF-K200DCA1, where available).
 - Do not use cleaners for CDs or cloths.

DVD-V DVD-A CD

Wipe with a damp cloth and then wipe dry.



■ Handling precautions

- Do not attach labels or stickers to discs. (This may cause disc warping and un-balanced rotation, rendering it unusable.)
- Do not write on the label side with a ball-point pen or other writing instrument.
- Do not use record cleaning sprays, benzine, thinner, static electricity prevention liquids or any other solvent.
- Do not use scratch-proof protectors or covers.
- Do not use the following discs:
 - Disc with exposed adhesive from removed stickers or labels (rented discs, etc.).
 - Discs that are badly warped or cracked.
 - Irregularly shaped discs, such as heart shapes.



- Do not place in the following areas:
 - In direct sunlight.
 - In very dusty or humid areas.
 - Near a heater.

Location of Controls

Remote Control Buttons

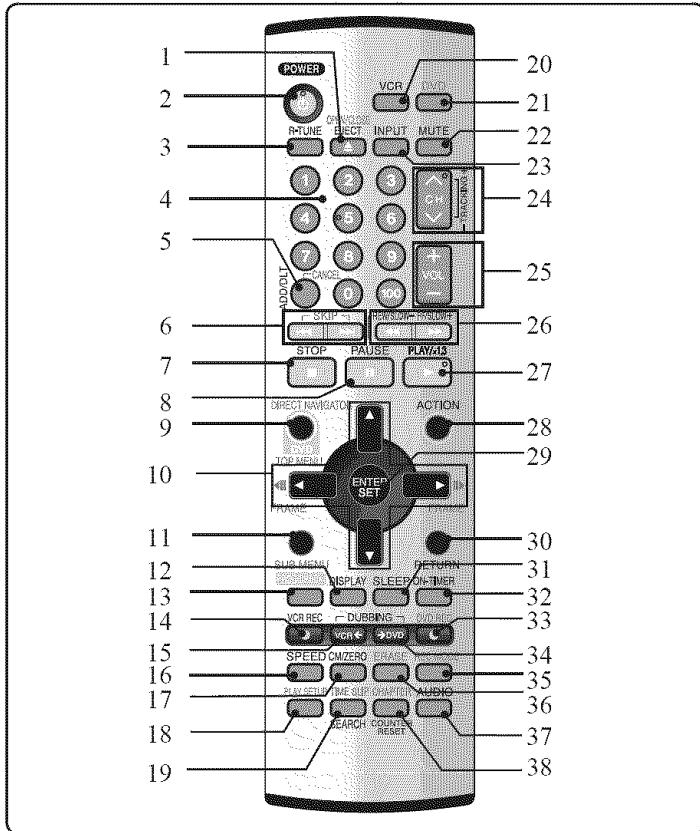

No.	Part Name	DVD	VCR
1	OPEN/CLOSE EJECT	Opens/closes disc tray.	Ejects tape.
2	POWER	Turns power on and off.	
3	R-TUNE	Returns to last viewed operation screen.	
4	NUMBER keys	Directly inputs numerical data.	
5	ADD/DLT CANCEL	Cancels input data.	Adds/deletes channels in unit memory. Cancels On Timer and VCR program settings.
6	SKIP	Skips to previous/next chapter.	
7	STOP	Stops playback, cancels resume, and stops recording.	Stops playback/recording.
8	PAUSE	Pauses playback/recording.	Pauses playback/recording. During playback pause, each additional press advances one frame.
9	DIRECT NAVIGATOR DVD TOP MENU	Displays Direct Navigator when playing a DVD-RAM and non-finalized DVD-R. Displays Disc Menu when playing a DVD Video and finalized DVD-R.	
10	▲▼◀▶	Use to move cursor for item selection in menu and operation screens. During a paused picture, ◀▶ operates Frame Advance.	Use to select items in on-screen displays.
11	SUB MENU	Displays sub menu while using Direct Navigator or Play list for editing.	

No.	Part Name	DVD	VCR
12	DISPLAY	Displays operation status.	
13	PROG/CHECK	Use when programming a timer recording and when displaying timer recording information.	Use when programming a timer recording and when displaying timer recording information.
14	VCR REC		Records onto a tape.
15	DUBBING VCR		Dubs a disc source onto a tape.
16	SPEED		Selects tape recording mode. Also, use to confirm tape recording mode during playback.
17	CM/ZERO	During playback, skips ahead 1 minute.	During playback, skips 1 to 3 minutes of tape. During Stop mode, moves playback position to counter zero ("0:00:00").
18	PLAY SETUP	Changes the initial playback settings during Play.	
19	TIME SLIP SEARCH	Displays TV image as a picture in picture. Skip over a specified time on the disc.	Performs an Index search.
20	VCR		Changes remote control to VCR mode.
21	DVD	Changes remote control to DVD mode.	
22	MUTE	Places unit in Mute mode.	
23	INPUT	Changes input mode.	
24	CH ▲ ▼ TRACKING+	Changes channels.	Changes channels. Adjusts tracking during VCR playback.
25	VOL+-	Adjusts volume.	
26	REW/SLOW-FF/SLOW+	Searches for previous/next scene. Pressing during pause mode starts slow motion playback. Pressing SLOW -/+ changes slow motion direction.	Rewinds/fast forwards tape. Pressing during pause mode starts slow motion playback. Pressing SLOW -/+ changes slow motion speed. Playback direction cannot be changed.
27	PLAY/×1.3	Begins playback. Holding down for 1 second switches to fast playback.	Begins playback.
28	ACTION	Displays MAIN MENU.	
29	ENTER SET	Use when finalizing menu entries.	
30	RETURN	Use when returning to the normal screen from a menu.	
31	SLEEP	Sets the sleep timer.	
32	ON-TIMER	Sets the On timer.	
33	DVD REC	Records onto a disc.	
34	DUBBING DVD	Dubs a tape source onto a disc.	
35	REC MODE	Sets to DVD Record mode.	
36	ERASE	Erases recording content.	
37	AUDIO	Switches the Audio mode.	
38	CHAPTER COUNTER RESET	Records the playback position.	Resets counter to zero.

Unit Buttons

■ Front View

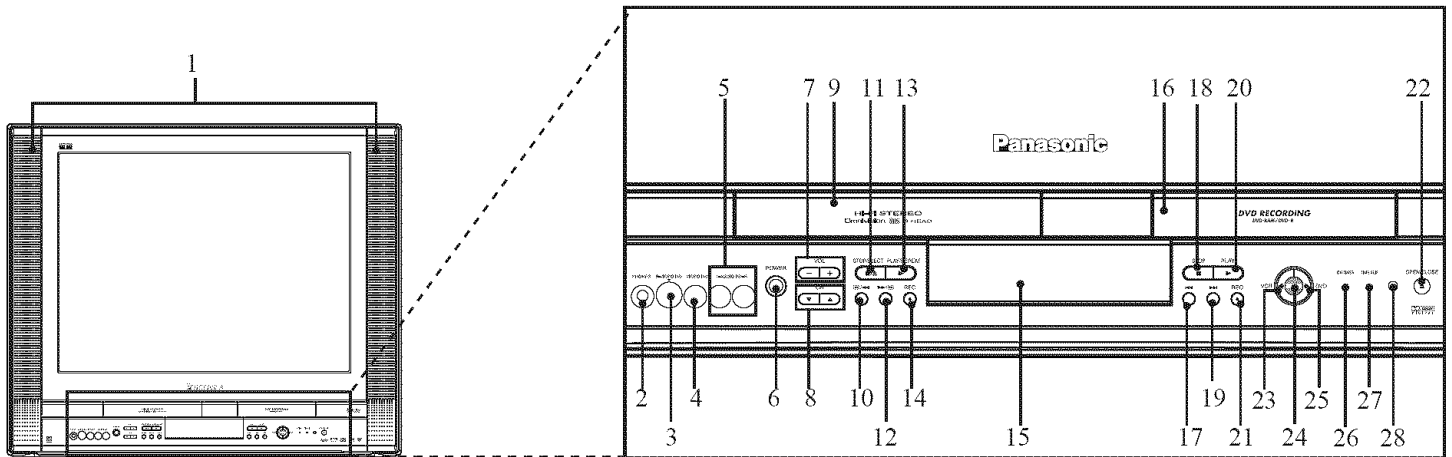

No.	Part Name	Caption
1	Built In Speakers	Equipped with 2 front speakers.
2	Phones Jack	Connect an ear phone or headphones.
3	S-Video Input Connector 2	Connect from other component. (LINE 2)
4	Video Input Connector 2	Connect from other component. (LINE 2)
5	Audio Input Connector 2	Connect from other component. (LINE 2)
6	POWER	Turns the unit on or off.
7	VOLUME UP/DOWN	Adjusts volume.
8	CHANNEL UP/DOWN or TRACKING UP/DOWN	Selects a channel. Reduces picture noise during Playback and Slow Motion. (VCR)
9	Cassette Compartment	Insert VHS tapes here.
10	REWIND/SEARCH	Rewinds tape and searches previous scene. Decreases slow motion speed in Still mode.
11	STOP/EJECT	STOP: Stops playback/recording. EJECT: Ejects the tape.
12	FAST FORWARD/SEARCH	Fast forwards tape and searches next scene. Increases slow motion speed in Still mode.
13	PLAY/REPEAT	PLAY: Begins playback. REPEAT: Sets to see a recording over and over.
14	REC	Records a program.

No.	Part Name	Caption
15	Sub Display	Displays information.
16	Disc Tray	Place compatible discs here.
17	SKIP ◀◀	Skips back one chapter or track. Goes to previous menu screen.
18	STOP	Stops playback/recording.
19	SKIP ▶▶	Skips one chapter or track. Goes to next menu screen.
20	PLAY	Begins playback.
21	REC	Records a program.
22	OPEN/CLOSE	Opens or closes the disc tray.
23	DUBBING VCR	Dubs a disc source onto a tape.
24	DUBBING Indicator	Dubbing indicator lights during dubbing.
25	DUBBING DVD	Dubs a tape source onto a disc.
26	ON TIMER Indicator (ORANGE)	Lights when the On Timer is set.
27	TIME SLIP Indicator	Lights when simultaneously playing and recording a DVD.
28	Remote Sensor	Receives infrared signal from remote control.

■ Front View (Sub Display)

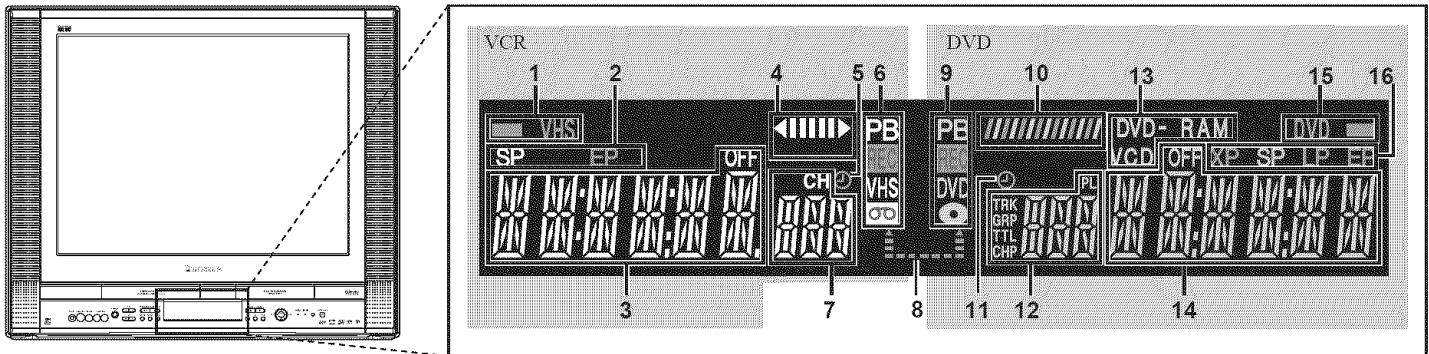

No.	Part Name	Caption
1	Tape Indicator	Lights when in VCR mode.
2	Tape Speed	Displays tape recording speed.
3	Main display section	Displays current time, tape counter, and function.
4	Direction	Displays tape direction.
5	Timer recording icon	Lights when a timer recording is set.
6	VCR Information	Displays VCR information.
7	Channel	Displays channel.
8	Dubbing Information	Displays dubbing direction. (source/target)

No.	Part Name	Caption
9	DVD Information	Displays DVD information.
10	Disc operation status	Displays condition of playback/recording.
11	Timer recording icon	Lights when a timer recording is set.
12	Number Information	Displays Chapter/Track No.
13	Disc Type	Displays Disc media being used.
14	Main display section	Displays DVD counter and function.
15	Disc Indicator	Lights when in DVD mode.
16	Rec mode	Displays type of recording.

■ Rear View

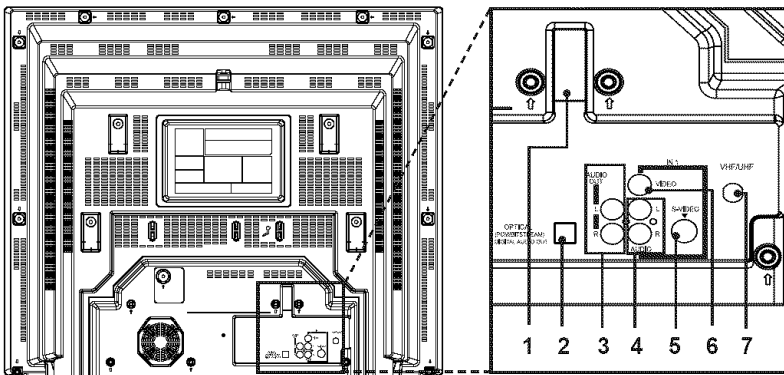

No	Part Name	Caption
1	AC Power Plug	When plugged into an AC outlet, this unit consumes 1.5 W of electric power in OFF condition.
2	Optical digital audio output connector	Outputs audio signal. (Digital)
3	Audio Output Connector (L/R)	Outputs audio signal. (Analog)
4	Audio Input Connector 1	Connect from other component. (LINE 1)

No	Part Name	Caption
5	S-Video Input Connector 1	Connect from other component. (LINE 1)
6	Video Input Connector 1	Connect from other component. (LINE 1)
7	VHF/UHF Antenna Input Terminal	Input terminal for an antenna or cable box signal.

Connections

Notes on connections

- Turn off the power supply for all components before making any connections.
- If the cables necessary for connecting a component to the system are not included with the component or available as an option, you may need to fashion a cable to suit the component concerned.
- Read the instruction manual for each system component carefully before connecting it.

Connecting the RF in Terminal

⚠ CAUTION

Overtightening "Nut type" RF coaxial cables may damage jacks. Finger tighten only.

■ Antenna Connection

Connect the cable from Antenna to the VHF/UHF terminal on the unit.

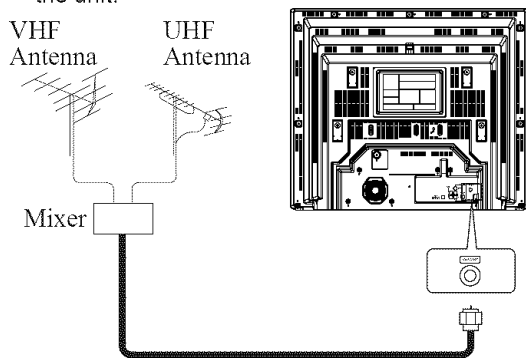

■ Cable Connection

Connect the cable supplied by your local cable company to VHF/UHF terminal on the unit.

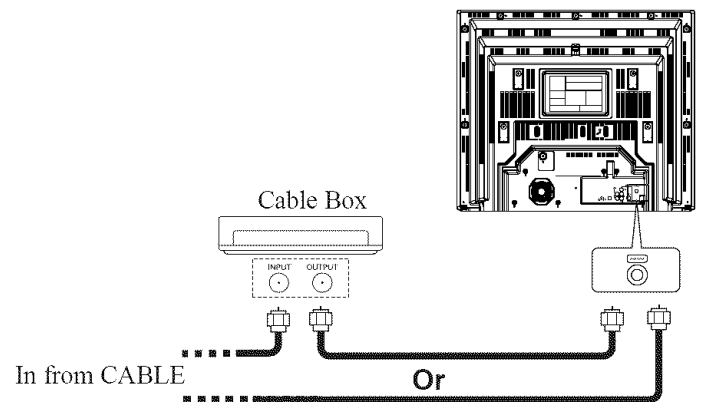

Note to CABLE system installer:

This reminder is provided to call the CABLE (Cable TV) System Installer's attention to Article 820-40 of the NEC that provides guidelines for proper grounding and, in particular, specifies that the cable ground shall be connected to the grounding system of the building, as close to the point of cable entry as practical.

Connecting the “1, 2” AV Input Terminals

Connects VCRs and other peripheral equipment

■ AV Input terminal 1 is used (S-VIDEO)

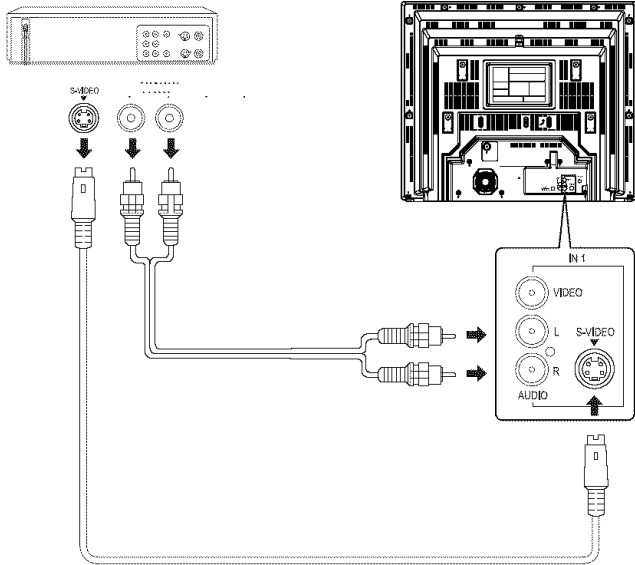

■ AV Input terminal 1 is used (VIDEO)

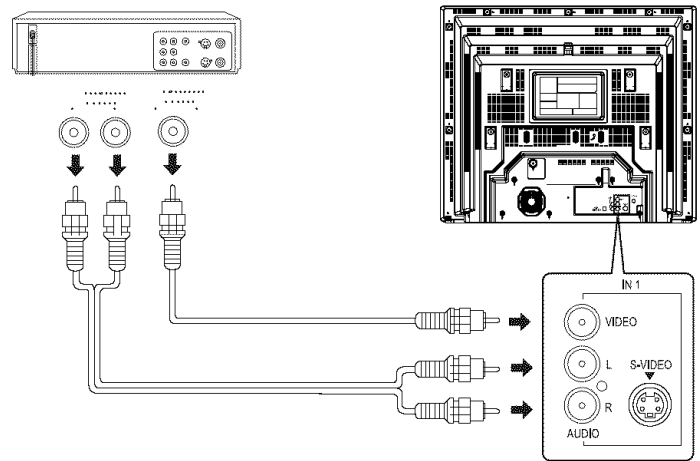

Notes:

- Similar connections are available at the “1, 2” AV input terminals.
- AV Input terminal 2 is located on the front of the unit.

Connecting the Headphones / Earphones Jack

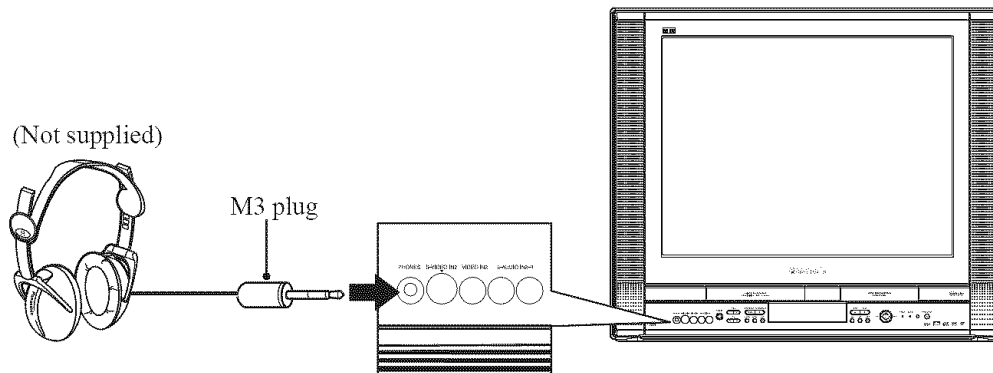

Connecting the Audio Output Terminal

Enjoy the powerful movie theater and hall-like sound available with multiple channel audio found on DVDs by connecting an amplifier and speakers. There are two types of connection, digital and analog.

▲ WARNING

Don't place the unit on amplifier or equipment that may become hot. The heat can damage the unit.

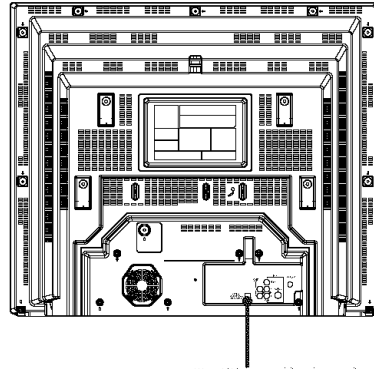

■ Digital connection

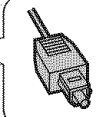

Firmly connect the cable to the connector.

Connect an AV amplifier with Dolby Digital or DTS decoders

Enjoy "Dolby Digital" or "DTS" surround sound.

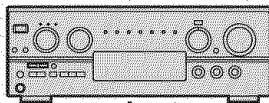
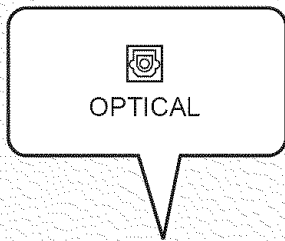

Amplifier with built in Dolby Digital or DTS decoders.

Speakers (example)

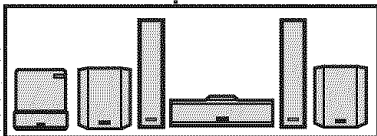

Please see amplifier manual for speaker requirements.

Connect a Digital amplifier

Smart one-line connection is possible.

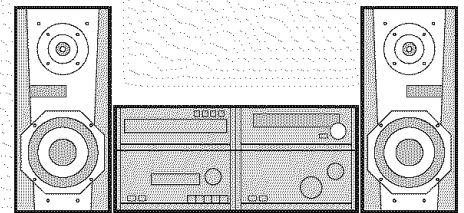
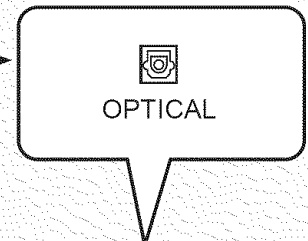

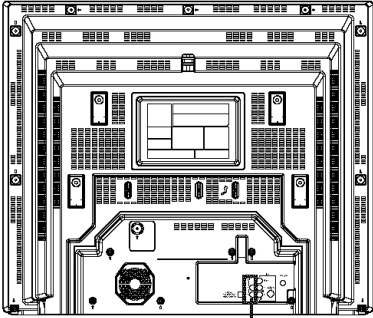

■ Analog connection

Connect an analog amplifier to enjoy high-quality stereo sound with sampling frequencies of 96 kHz.

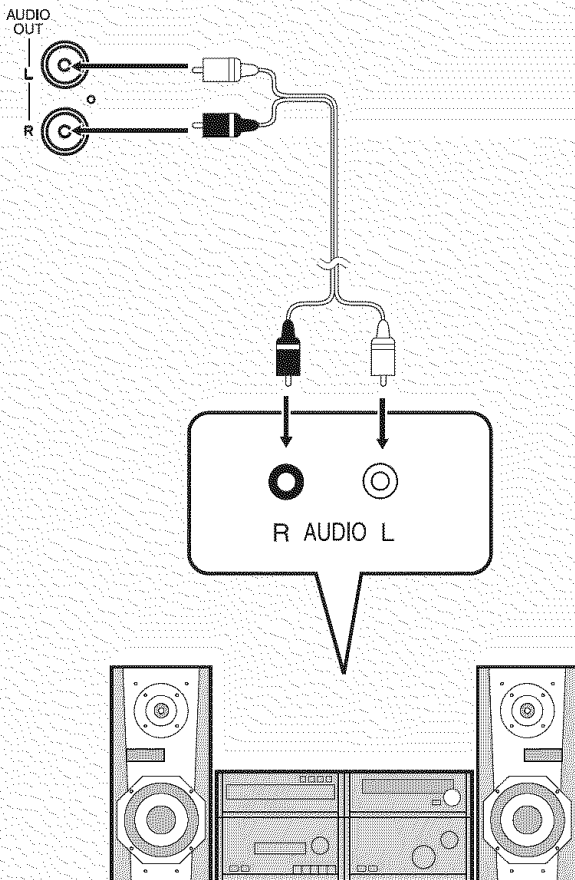

IMPORTANT NOTE:

Caution for optical digital audio output connector:

- Be sure to refer to pages 67-69 regarding output settings of Dolby Digital, dts, and PCM.
- CDs can be played as usual.
- Audio from the Digital Audio Out terminal is only output during playback.
- When connecting an amplifier which contains the Dolby Digital or dts decoder, be sure to select "Bitstream". When connecting an amplifier which does not contain the Dolby Digital or dts decoder, be sure to select "PCM". (See pages 67-69.) Otherwise, attempting to play a DVD may cause such a high level of noise that it may harm your hearing and damage your speakers.

Notes:

- Some dts decoders which do not support DVD-dts Interface may not work properly with the unit.
- Avoid bending/twisting the optical digital cable when connecting.

For your reference:

- Dolby Digital is a digital sound compression technique developed by the Dolby Laboratories Licensing Corporation. Supporting 5.1-channel surround sound, as well as stereo (2-channel) sound, this technique enables a large quantity of sound data to be efficiently recorded on a disc.
- Linear PCM is a signal recording format used in CDs. While CDs are recorded in 44.1 kHz/16 bit, DVDs are recorded in 48 kHz/16 bit up to 96 kHz/24 bit.
- If you have a Dolby Pro Logic Surround decoder, you will obtain the full benefit of Pro Logic from the same DVD movies that provide full 5.1 channel Dolby Digital soundtracks, as well as from titles with the Dolby Surround mark. For information on Panasonic or Technics Dolby Pro Logic Surround Sound Decoders please contact your local dealer.

Manufactured under license from Digital Theater Systems, Inc. US Pat. No's. 5,451,942, 5,956,674, 5,974,380, 5,978,762, 6,487,535 and other U.S. and world-wide patents issued and pending. "DTS" and "DTS 2.0 + Digital Out" are trademarks of Digital Theater Systems, Inc. Copyright 1996, 2003 Digital Theater Systems, Inc. All Rights Reserved.

Manufactured under license from Dolby Laboratories. "Dolby," "Pro Logic," and the double-D symbol are trademarks of Dolby Laboratories.

Tuning TV

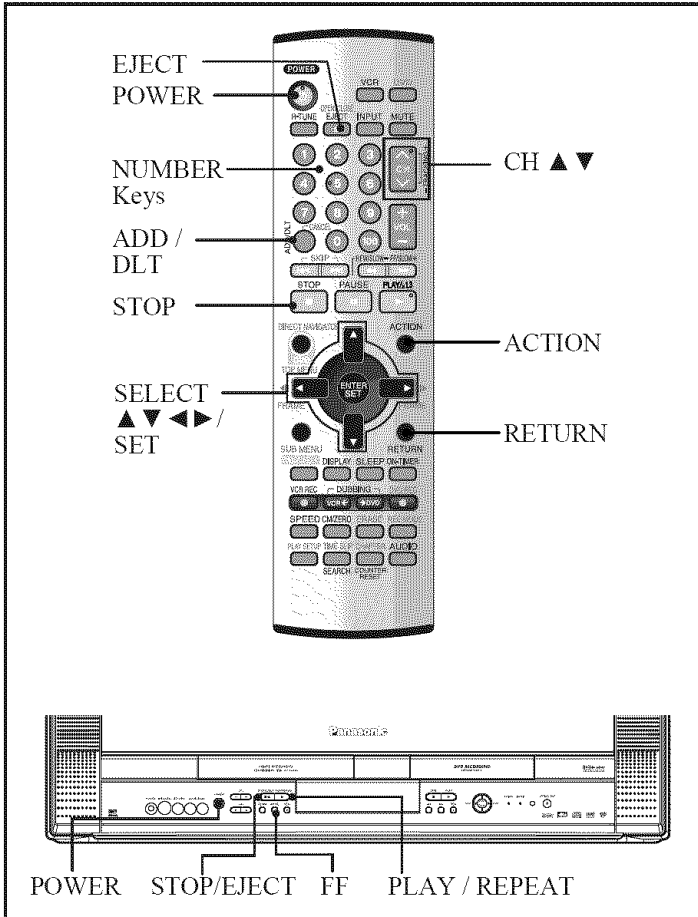

Case 2

If setup is incomplete, the following screen appears. Check connection of Antenna/Cable to the RF in Terminal, then try to manually set the clock as follows.



a. Press ACTION on the Remote Control to display SET CLOCK Menu screen.

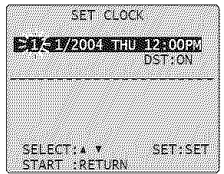

b. Press ▲▼ to select the month and press SET to set. In the same manner, select and set the date, year, time, and DST (Daylight Saving Time).

• Press ◀ repeatedly to move the cursor. Press ▲▼ to make a correction.

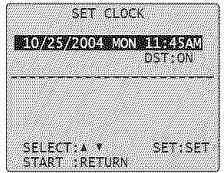

c. Press RETURN twice to start CLOCK and exit.

Initial Setup (Ready to Play)

Please make all cable or antenna connections before powering on. Plug the unit power cord into an AC wall outlet.

1 Press POWER on the Remote Control or unit. Auto channel and clock set starts.

- If you use a cable box, turn it on and set it to the Public Broadcasting Service (PBS) channel in your time zone. If you use a DSS receiver, it must be turned off.

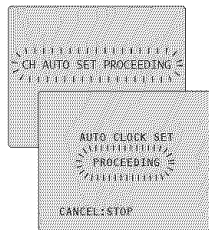

- Function buttons are void during Initial Setup.
- To eject a tape during Auto Set, press the unit STOP/EJECT button twice. Then, make settings manually. (See pages 17-18.)
- If Auto Clock Set takes more than 30 minutes, press STOP and perform settings manually. (See pages 17-18.)

Case 1

Settings are made automatically. When complete, this screen appears.

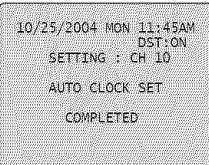

Automatic Channel Setting

1 Press ACTION to display MAIN MENU.

2 Press ▲▼◀▶ to select "CH."

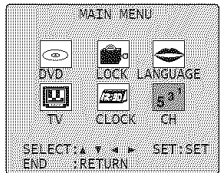

3 Press SET to display SET UP CHANNEL screen.

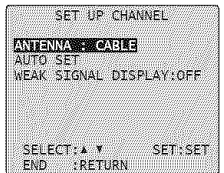

4 Press ▲▼ to select "ANTENNA," then press SET to set your antenna system ("TV" or "CABLE").

5 Press ▲▼ to select "AUTO SET," then press SET.

Note:

- After Channel Auto Set is finished, Clock Auto Set will be performed. (If clock is set manually, Clock Auto Set will not be performed.)

Add or Delete a Channel

To add channel:

Select channel with NUMBER keys and press ADD/DLT.

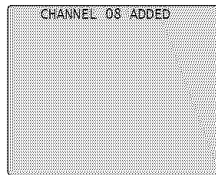

To delete channel:

Select channel with CH ▲▼ or NUMBER keys and press ADD/DLT.



Automatic Clock Setting

1 Press ACTION to display MAIN MENU.

2 Press ▲▼◀▶ to select "CLOCK."

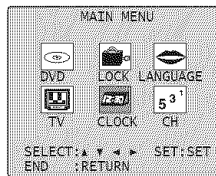

3 Press SET to display SET CLOCK screen.

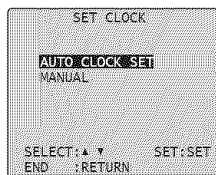

4 Press ▲▼ to select "AUTO CLOCK SET," then press SET.

Manual Clock Setting

1 Press ACTION to display MAIN MENU.

2 Press ▲▼◀▶ to select "CLOCK."

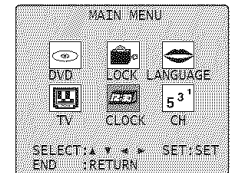

3 Press SET to display SET CLOCK screen.

("TIME ZONE ADJUST" appears only when auto clock is set.)

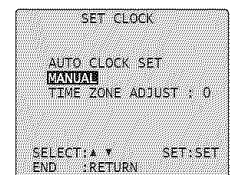

4 Press ▲▼ to select "MANUAL," then press SET.

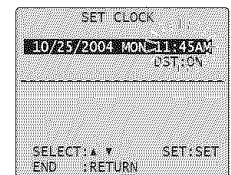

5 Press ▲▼ and press SET to select and set the month, date, year, time, and DST (Daylight Saving Time).

To Make Corrections, repeatedly press ◀ to move to error, then correct.

6 Press RETURN twice to start the clock and exit this mode.

Time Zone Adjust

(Only when Auto Clock is set.)

- 1 Press ACTION to display MAIN MENU.
- 2 Press ▲▼◀▶ to select "CLOCK."

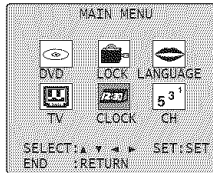

- 3 Press SET to display SET CLOCK screen.

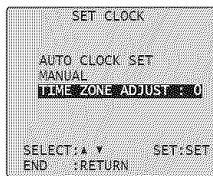

- 4 Press ▲▼ to select "TIME_ZONE_ADJUST" and press SET to subtract or add hour(s) as necessary.

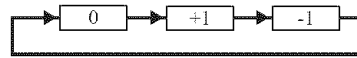
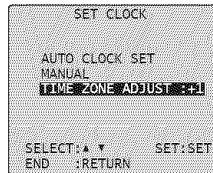

- 5 Press RETURN twice to exit.

Note:

- If set manually time zone does not appears.

Change Language Setting

- 1 Press ACTION to display MAIN MENU.
- 2 Press ▲▼◀▶ to select "LANGUAGE."

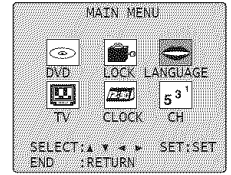

- 3 Press SET repeatedly.

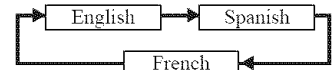

For English

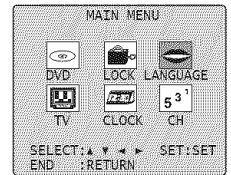

For Spanish

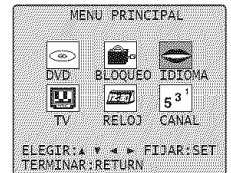

For French

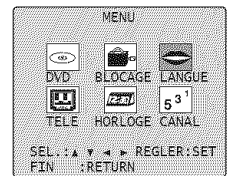

- 4 Press RETURN to exit.

Reset all unit Memory Functions

Returns to factory setting. Use if relocating unit, or if Initial Setup needs to be redone.

- Make sure a tape and/or disc is not inserted in unit.

- 1 Turn the unit Power on.
- 2 Hold down both PLAY/REPEAT and FF on the unit for more than 5 seconds.
 - The power will shut off.
 - Please ignore "NO CASSETTE" warning.
- 3 Perform "Initial Setup" on page 16.

Weak Signal Display Feature

When "ON" is selected, the picture is displayed even when a broadcast signal is weak or non-existent.

- 1 Press ACTION to display MAIN MENU.
- 2 Press ▲▼◀▶ to select "CH."
- 3 Press SET to display SET UP CHANNEL screen.

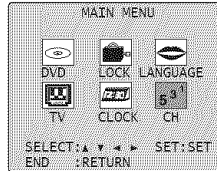

- 4 Press ▲▼ to select "WEAK SIGNAL DISPLAY."
- 5 Press SET to set "ON" or "OFF."

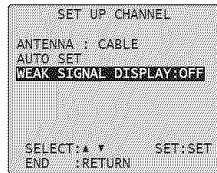

- ON:**
Picture is displayed regardless of signal condition, and may not always be clearly visible.
- OFF:**
Screen turns solid blue when signal is absent or weak.

Note:

- If unit is connected to equipment which has blue back feature, selecting "ON" will have no effect on the other equipment.

- 6 Press RETURN twice to return to the normal screen.

Front Display Setting

You can set the Front Display (Sub Display) to light up even when this unit is in OFF condition.

- 1 Press ACTION to display MAIN MENU.
- 2 Press ▲▼◀▶ to select "TV."
- 3 Press SET to display SET UP TV screen.

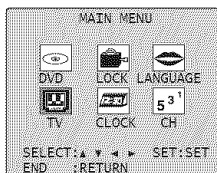

- 4 Press ▲▼ to select "FRONT DISPLAY."
- 5 Press SET to set "ON" or "OFF."

- ON:**
Sub Display lights up when power is in off condition.
- OFF:**
Sub Display does not light in power off condition.

Note:

- Even when Front Display is set to OFF, the display will light up during recording or dubbing.

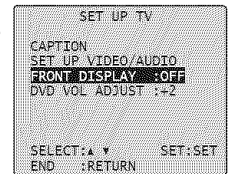

- 6 Press RETURN twice to return to the normal screen.

DVD Volume Adjust

Some DVDs are recorded at lower than average volume levels. For these DVDs, this unit can be set so that the average volume is increased automatically.

- 1 Press ACTION to display MAIN MENU.
- 2 Press ▲▼◀▶ to select "TV."
- 3 Press SET to display SET UP TV screen.

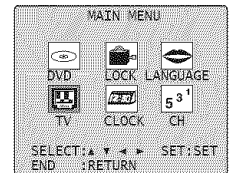

- 4 Press ▲▼ to select "DVD VOL ADJUST."
- 5 Press SET to set the level (0, +1, or +2).

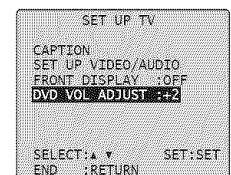

- 6 Press RETURN twice to return to the normal screen.

Note:

- DVD Volume Adjust works only when sound is in Dolby Digital.

TV Operation

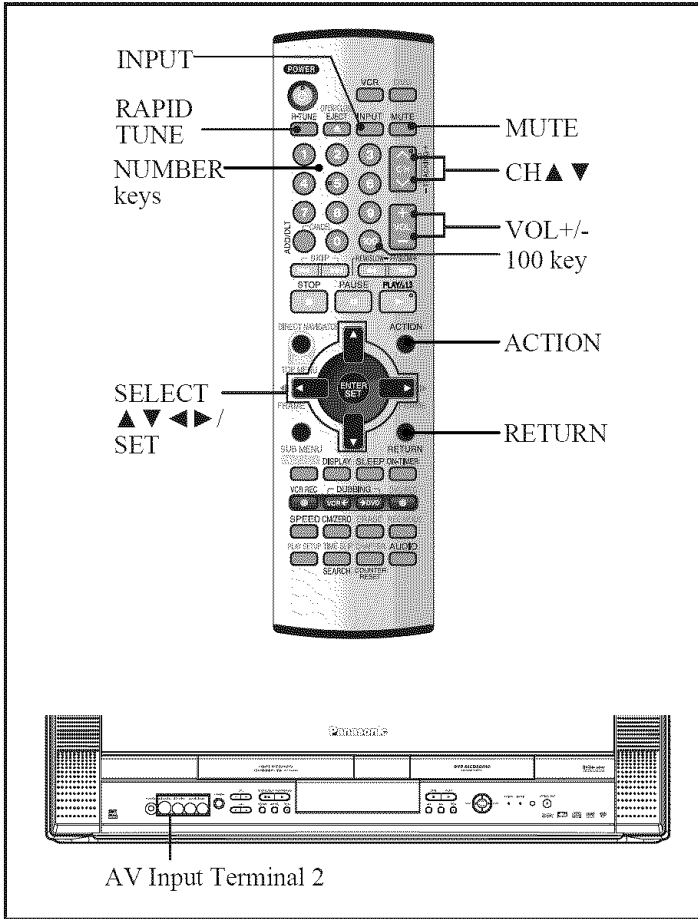

Method 2:

Press INPUT. The display will change as follows.



LINE 1:

Signal of source connected to AV Input terminal 1 is displayed. (Rear of the unit.)

LINE 2:

Signal of source connected to AV Input terminal 2 is displayed.

TUNER:

Signal of source connected to VHF/UHF terminal is displayed.

Using the CH/VOL Button

Select desired channel:

Press CH ▲ ▼ or NUMBER keys.

Adjust desired volume level:

Press VOL + or VOL -.

Using the Number and 100 keys

When selecting CABLE channels 100 to 125 with the NUMBER keys, first press the 100 key, and then enter the remaining two digits.

Example 1:

To select channel 125, first press the 100 key, then 2, then 5.

Example 2:

To select channel 12, first press the 1 key, then 2.

Example 3:

To select channel 2, first press the 0 key, then 2.

Selecting Input Mode

Method 1:

Press CH ▲ ▼. The display will change as follows.

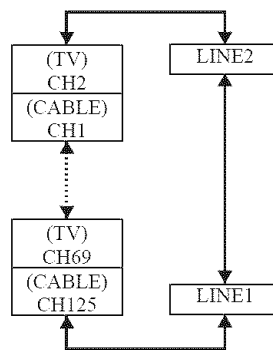

Notes:

- The diagram at right is an example.
- TV CH 2 and CABLE CH 1 represent the lowest channels in memory, while TV CH 69 and CABLE CH 125 represent the highest channels in memory.

Rapid Tune

Press R-TUNE to display the last channel you were watching.

Audio Mute

Press MUTE to instantly mute the sound. Press again to restore the previous sound level.

MTS Broadcast / TV Stereo System

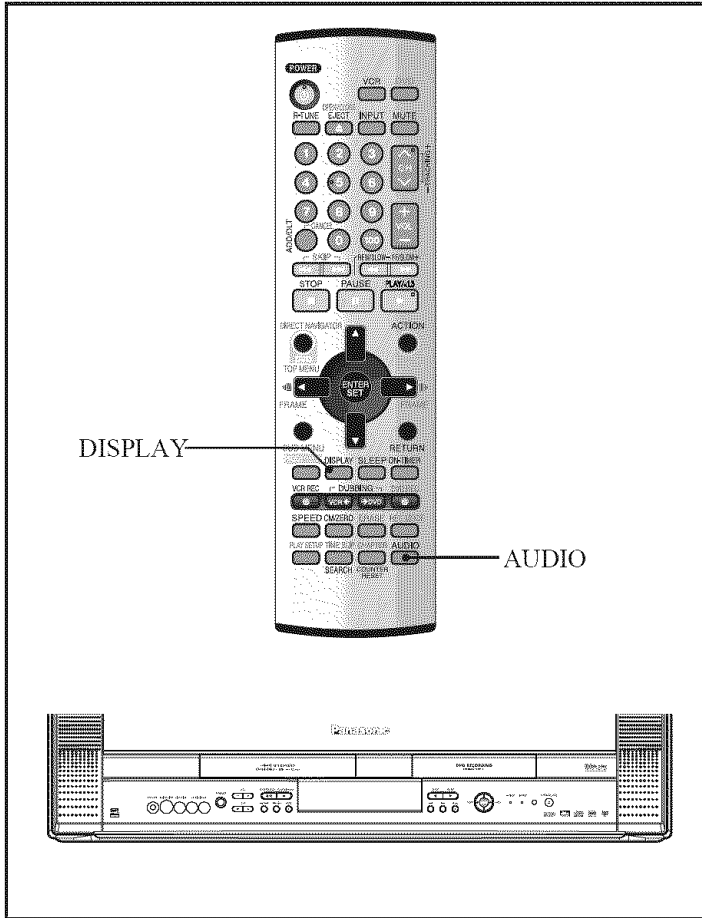

Equipped with **dbx**[®]-TV Noise Reduction for true MTS reproduction. **dbx**[®]-TV Noise Reduction is required for good stereo separation and audio fidelity. **dbx**[®] is a registered trademark, and is licensed by **dbx**[®] Technology Licensing.

Audio Mode for TV Viewing

- 1 Press **AUDIO** to select the desired audio mode as described above. (Arrow shows selection.)
 - Each press of **AUDIO** will change the audio mode as shown below.
 - "SAP" is selected with first press of **AUDIO**.

< Example >

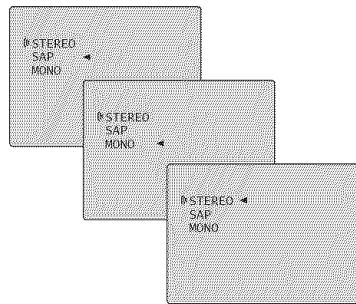

Receivable Broadcast Types

The following are possible audio broadcast types and on-screen displays. The signal being received is indicated with a "Ⓜ" mark while the selected audio mode is indicated with an arrow. To change the audio mode for these broadcasts, see the "Audio Mode for TV Viewing" section.

- 1 Press **DISPLAY** to display the broadcast signal being received.

■ MTS Stereo broadcast:

Multi-channel Television Sound Stereo broadcast. Select **STEREO** audio mode.

- If stereo broadcast is weak and the display flickers, select **MONO** audio mode for possible improvement.

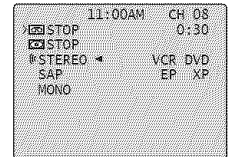

■ SAP broadcast:

Secondary Audio Program (sub language).

Select **SAP** audio mode for the sub language.

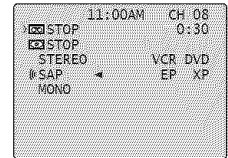

■ MTS Stereo and SAP broadcast:

Multi-channel Television Sound Stereo (main language) and Secondary Audio Program (sub language) broadcasts are being received simultaneously. Select the **STEREO** or **SAP** audio mode.

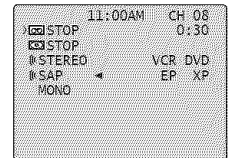

■ MONO broadcast:

Normal monaural sound broadcast.

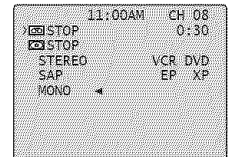

TV Timer Features

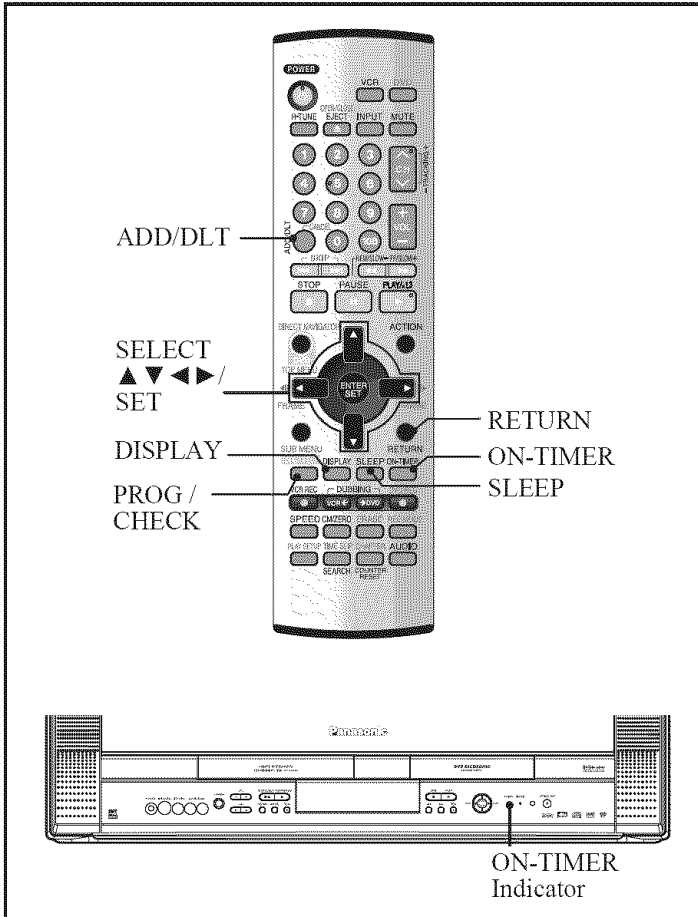

ON-TIMER

This unit can be set to automatically power on in one of 3 modes (TV, VCR Playback, or Disc.)

- 1 Press ON-TIMER to display ON TIMER screen.
- 2 Press ▲▼ to select desired settings.
 - When the setup is completed and press SET, "SET COMPLETED" is displayed.

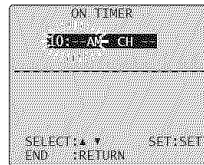

- Make sure a tape is inserted if Playback mode is selected.
- Make sure a disc is inserted if Disc (DVD/CD) mode is selected.

ON-TIMER mode selection order

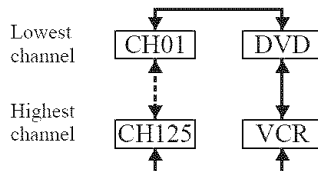

■ To Make Corrections, use ▲▼ and ◀▶ to move back and correct.

- 3 Press RETURN to set ON TIMER.
 - "ON TIMER SET" is displayed.

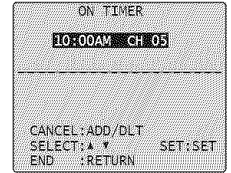

■ To Cancel ON-TIMER,

Repeat step 1. Then, press ADD/DLT to clear the time in steps 2-3. Now, press RETURN to end. "ON TIMER END" briefly appears on-screen.

Notes:

- If no button on the Remote Control or unit is pressed within 60 minutes after unit turns itself on, it will turn itself back off.
- If an interactive DVD (with menu) is played back using ON TIMER, the disc menu will continue to be displayed for operation purposes.

Sleep Timer

This unit can be set for auto power off.

- 1 Press SLEEP repeatedly to select the desired time.

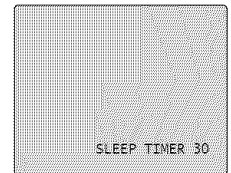
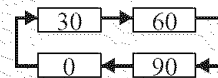

■ To cancel,

press SLEEP repeatedly until 0 appears.

- 2 The indication goes off a few seconds after the adjustment is finished.

Note:

- Pressing DISPLAY with sleep timer set displays remaining time.

Closed Caption System

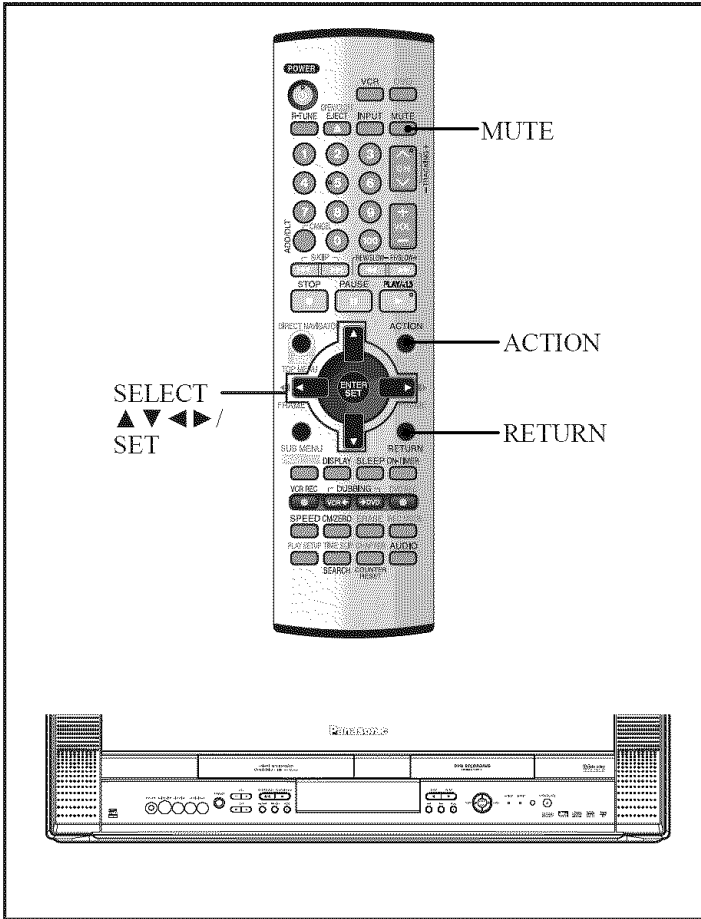

Closed Caption is ...

This multi-use system not only allows the hearing impaired to enjoy selected programs, but also allows one to watch programs with the volume muted.

Closed Caption Mode Feature

1 Press ACTION to display MAIN MENU.

2 Press ▲▼◀▶ to select "TV."

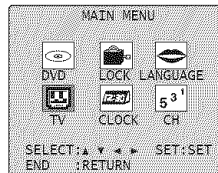

3 Press SET to display SET UP TV screen.

4 Press ▲▼ to select "CAPTION".

5 Press SET to display CAPTION screen.

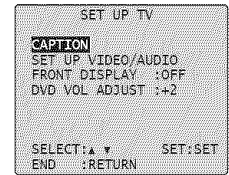

6 Press ▲▼ to select "CAPTION MODE."

7 Press SET repeatedly to select mode.

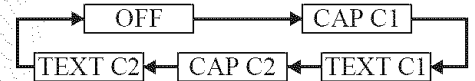
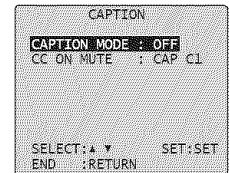

■ Caption Mode: CAP C1 or C2

A narration of selected TV programs is displayed. Check TV program listings for CC (Closed Caption) broadcasts.

■ Caption Mode: TEXT C1 or C2

Most of the screen will be blocked out. When the TV station broadcasts information, such as program listings, it will appear in this space.

■ Caption Mode: OFF

Closed Caption/Text narration will not be displayed.

8 Press RETURN three times to return to the normal screen.

Notes:

- The closed caption or text signal may be broadcast over C1, C2, or both. Also, text contents can vary so you may wish to try different settings.
- The closed caption display may overlap the display of a Disc.

Caption On Mute Feature

Closed Caption narration, if available, is displayed when MUTE button is pressed for silence.

- 1 Press ACTION to display MAIN MENU.
- 2 Press ▲▼◀▶ to select "TV."
- 3 Press SET to display SET UP TV screen.

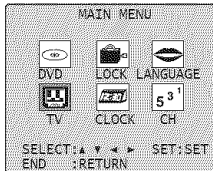

- 4 Press ▲▼ to select "CAPTION".
- 5 Press SET to display CAPTION screen.

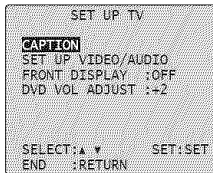

- 6 Press ▲▼ to select "CAPTION MODE."
- 7 Press SET repeatedly to select "OFF."

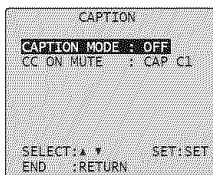

- 8 Press ▲▼ to select "CC ON MUTE."
- 9 Press SET repeatedly to select desired mode.
 - The caption may be broadcast over CAP C1 or C2.

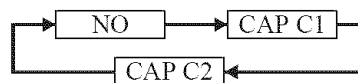
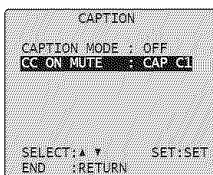

■ CC ON MUTE: CAP C1 or C2

A narration of selected TV programs is displayed when MUTE button is pressed for silence.

■ CC ON MUTE: NO

A narration will not be displayed when MUTE button is pressed for silence.

- 10 Press RETURN three times to return to the normal screen.

- 11 Press MUTE to mute the sound and display closed captioning.

- To cancel, press MUTE again.

Note:

- When a disc supporting closed captions is used, the subtitle and the closed caption may overlap. In this case, turn the subtitle or caption mode off. (See page 55.)

Recording and Playing Back a Closed Caption/Text Program

■ Record:

Record normally. Closed Caption/Text signal, if present, is recorded automatically.

■ Playback:

Start playback. Perform steps to select desired caption mode.

Video / Audio Setting

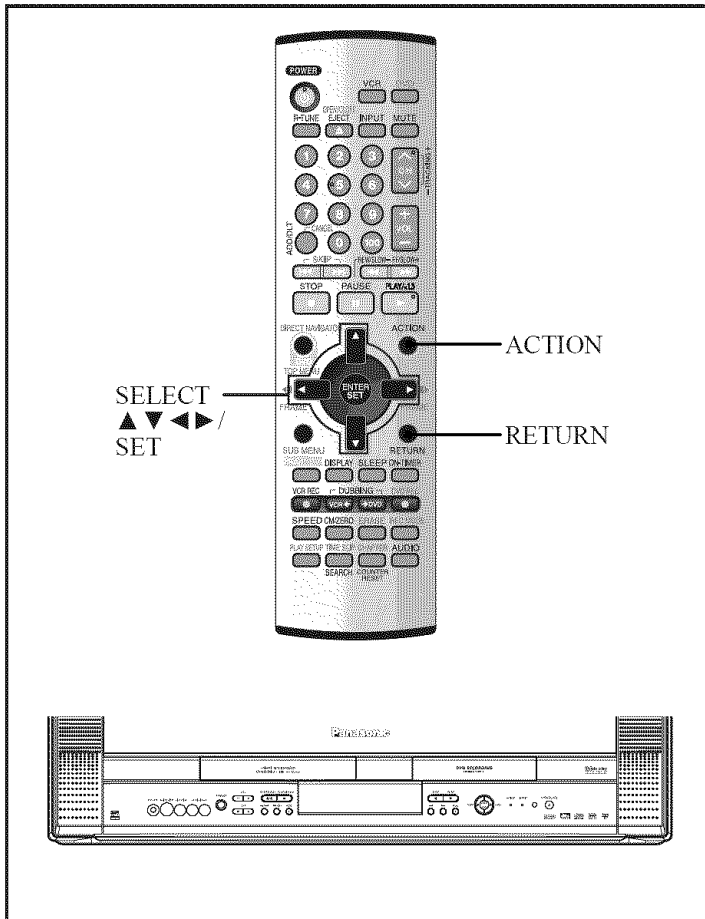

This feature allows easy setting of picture and sound suitable for each program source.

Video Menu

- 1 Press ACTION to display MAIN MENU.
- 2 Press ▲▼◀▶ to select "TV."
- 3 Press SET to display SET UP TV screen.

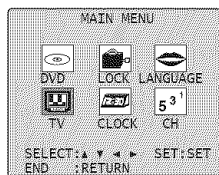

- 4 Press ▲▼ to select "SET UP VIDEO/AUDIO."
- 5 Press SET to display SET UP VIDEO/AUDIO screen.

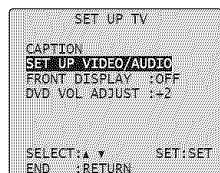

- 6 Press ▲▼ to select "VIDEO MENU."
- 7 Press SET repeatedly to select desired mode.



NORMAL	Factory setting.
MOVIE	Picture is adjusted for a movie-like feel.
NIGHT	Color and picture intensity are adjusted to be easier on the eyes for night viewing.

- 8 Press RETURN three times to end setup.

Audio Menu

- 1 Do steps 1 - 5 at left.
- 2 Press ▲▼ to select "AUDIO MENU."
- 3 Press SET to select desired mode.

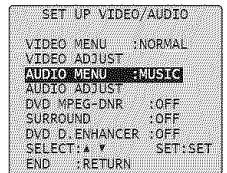

MUSIC	Sound suited to music. (Factory setting)
SPEECH	Sound suited to dialogue.
NORMAL	
AUTO	[Audio AGC (Auto Gain Control)] The sound level is automatically adjusted to suit the program source.
MOVIE	Sound suited to movies.

- 4 Press RETURN three times to end setup.

Notes:

- The effects of this feature on the signal are not output to the Audio/Video Output Connector.
- When AUDIO MENU mode is "AUTO," the AUDIO ADJUST setting will be "STANDARD."
- AUDIO MENU settings remain in memory.
- VIDEO MENU settings do not remain in memory.

Video Adjustment

1 Press ACTION to display MAIN MENU.

2 Press ▲▼◀▶ to select "TV."

3 Press SET to display SET UP TV screen.

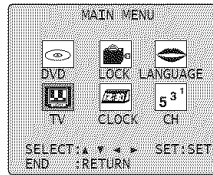

4 Press ▲▼ to select "SET UP VIDEO/AUDIO."

5 Press SET to display SET UP VIDEO/AUDIO screen.

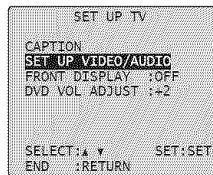

6 Press ▲▼ to select "VIDEO ADJUST."

7 Press SET to display VIDEO ADJUST screen.



8 Press ▲▼ to select an item.

9 Press ◀▶ to adjust.

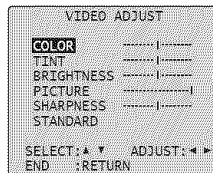

COLOR Control	Adjust color intensity.
TINT Control	Adjust for natural flesh tones.
BRIGHTNESS Control	Adjust picture brightness.
PICTURE Control	Adjust picture intensity by adjusting both contrast and color level in the proper balance.
SHARPNESS Control	Increases or decreases the level of detail in the image.

■ To Reset VIDEO Controls.

Press ▲▼ and SET to select and set "STANDARD." All controls return to their factory settings.

10 Press RETURN four times to end setup.

Audio Adjustment

1 Press ACTION to display MAIN MENU.

2 Press ▲▼◀▶ to select "TV."

3 Press SET to display SET UP TV screen.

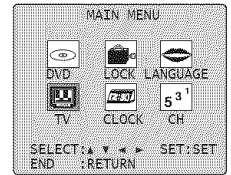

4 Press ▲▼ to select "SET UP VIDEO/AUDIO."

5 Press SET to display SET UP VIDEO/AUDIO screen.

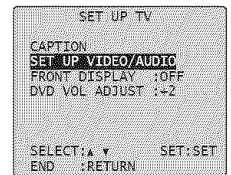

6 Press ▲▼ to select "AUDIO ADJUST."

7 Press SET to display AUDIO ADJUST screen.



8 Press ▲▼ to select an item.

9 Press ◀▶ to adjust.



BASS Control	To adjust the intensity of low frequency sound.
TREBLE Control	To adjust the intensity of high frequency sound.
BALANCE Control	Controls the difference in audio level between the left and right speaker.

• The levels set here do not affect other audio equipment when connected to the Audio Output L/R Connector.

■ To Reset AUDIO Controls.

Press ▲▼ and SET to select and set "STANDARD." All controls return to their factory settings.

10 Press RETURN four times to end setup.

DVD MPEG-DNR

RAM DVD-R DVD-V

Reduces noise and picture degradation. (DVD mode only)

- 1 Press ACTION to display MAIN MENU.
- 2 Press ▲▼◀▶ to select "TV."
- 3 Press SET to display SET UP TV screen.
- 4 Press ▲▼ to select "SET UP VIDEO/AUDIO."
- 5 Press SET to display SET UP VIDEO/AUDIO screen.

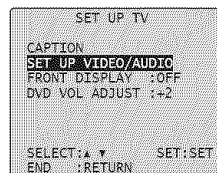
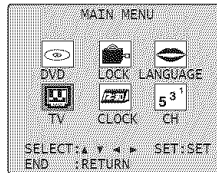

- 6 Press ▲▼ to select "DVD MPEG-DNR."
- 7 Press SET to set "ON" or "OFF."

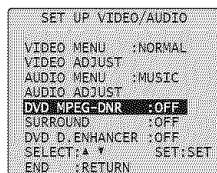

- 8 Press RETURN three times to end setup.

Surround Sound System

You can hear a deeper, 3-D sound effect using just the unit's two front speakers.

- 1 Press ACTION to display MAIN MENU.
- 2 Press ▲▼◀▶ to select "TV."
- 3 Press SET to display SET UP TV screen.
- 4 Press ▲▼ to select "SET UP VIDEO/AUDIO," then press SET.

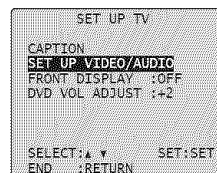
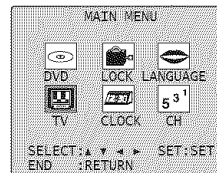

- 5 Press ▲▼ to select "SURROUND."
- 6 Press SET to set "ON" or "OFF."

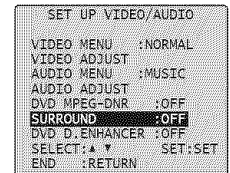

- 7 Press RETURN three times to end setup.

Notes:

- Surround sound effect is not available for normal (mono) broadcasts.
- The surround effect is not output to Audio Output L/R Connector.
- **RAM DVD-R DVD-V**
 - Only for Dolby Digital with 2 or more channels.
 - Turn SURROUND off if it causes distortion.
 - SURROUND does not work for SAP recordings.

DVD Dialog Enhancer

DVD-V (Dolby Digital, 3-channel or over only, including a center channel)

The volume of the center channel is raised to make dialogue easier to hear.

- 1 Press ACTION to display MAIN MENU.
- 2 Press ▲▼◀▶ to select "TV."
- 3 Press SET to display SET UP TV screen.
- 4 Press ▲▼ to select "SET UP VIDEO/AUDIO," then press SET to display SET UP VIDEO/AUDIO screen.
- 5 Press ▲▼ to select "DVD D.ENHANCER."
- 6 Press SET to set "ON" or "OFF."

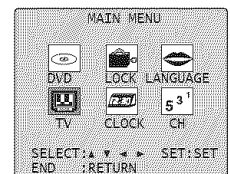

- 5 Press ▲▼ to select "DVD D.ENHANCER."
- 6 Press SET to set "ON" or "OFF."



- 7 Press RETURN three times to end setup.

Note:

- This sound enhancement is not output to the Audio Output L/R Connector.

Before using the VCR

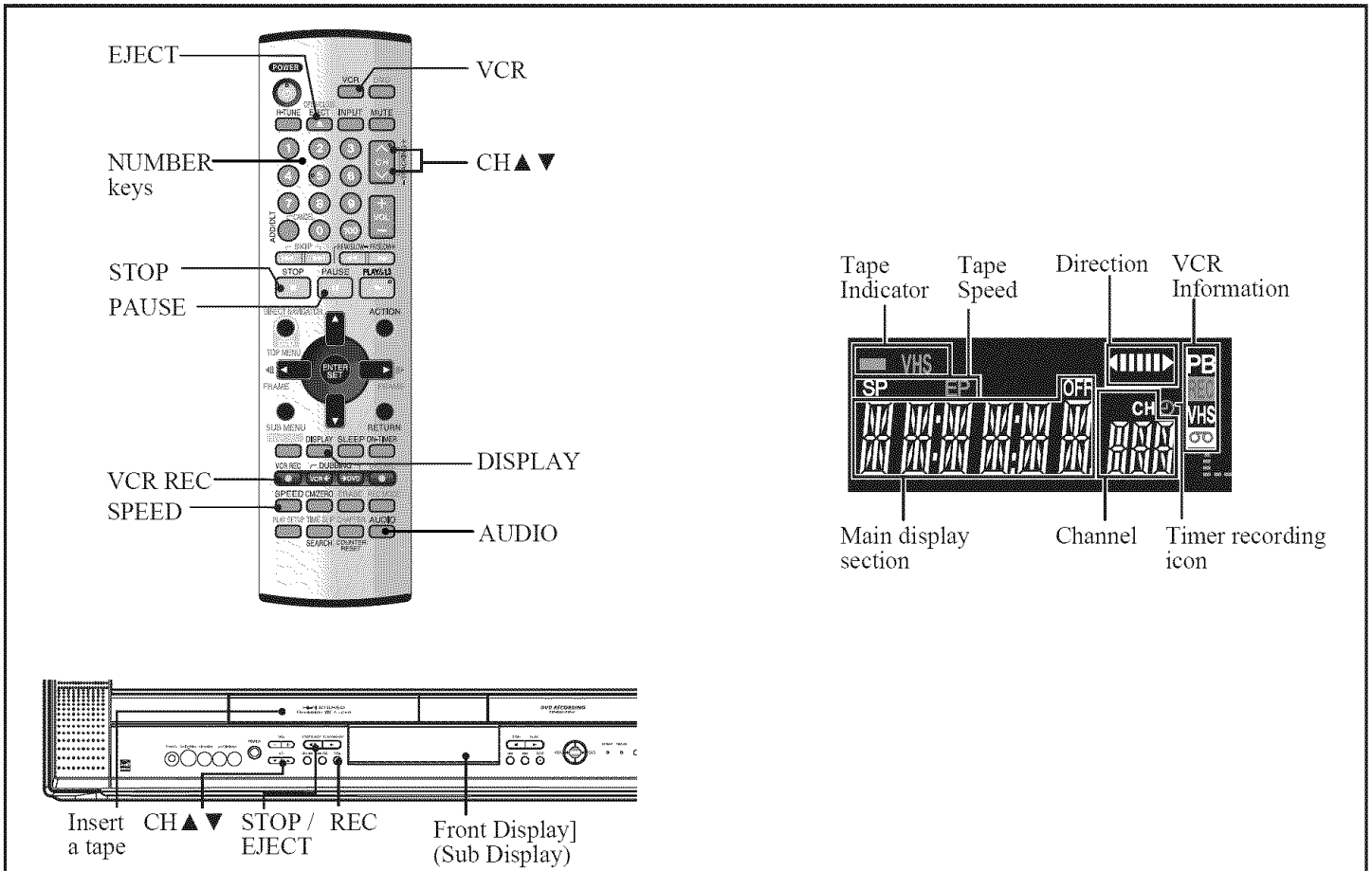

Before using VCR Functions

- 1 Confirm that tape is inserted.
- 2 Press VCR.
 - The indication "VHS" flashes in the Front Display.

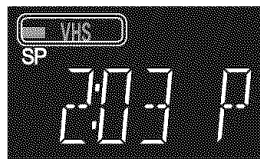
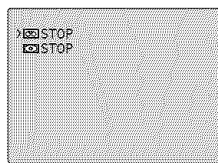

- 3 Each operation is carried out.

Inserting a Tape

- 1 Insert a tape.
 - The unit power comes on automatically.

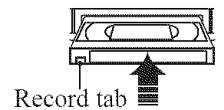

To prevent tape jam,
remove loose or peeling labels from tapes.

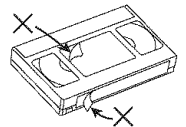

- Eject tape
 - Press EJECT on the remote or STOP/EJECT on the unit.

Recording Television Programs

Record On a Tape

- 1 Insert a tape with record tab.**
 - The unit power comes on automatically.
- 2 Press CH ▲▼ or NUMBER keys to Select Channel.**
 - For "LINE" input, see page 20.

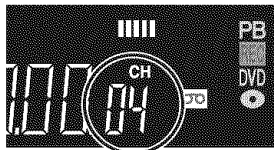

- 3 Press SPEED to select recording speed.**
 - Selected speed is displayed.

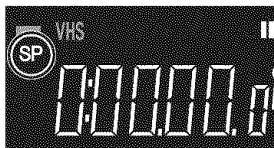

SP = Standard Play
EP = Extra Long Play

Recording modes and approximate recording times

Only use tapes with the **MS** mark in this unit.

Tape Speed Setting	Type of Video Cassette		
	T60	T120	T160
SP (Standard Play)	1 Hour	2 Hours	2 Hours 40 Minutes
EP (Extra Long Play)	3 Hours	6 Hours	8 Hours

- 4 Press VCR REC to start recording.**
 - You cannot view another channel during recording.

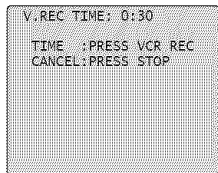
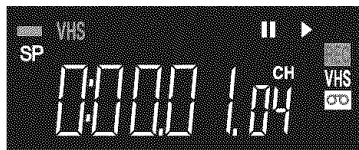

One Touch Recording (OTR)

Press VCR REC repeatedly to set the recording length (30 min - 4 hours.)

- The unit stops recording at a preset time.

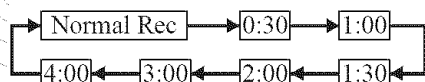

Pause a Recording

- Press PAUSE.
- Press PAUSE to resume recording.

Notes:

- After the unit has been in Rec Pause mode for 5 minutes, it will stop automatically to protect the tape and the video head.
- The remaining recording time of an OTR can be displayed by pressing DISPLAY.
- When an OTR is paused, the pause time is also factored into the total recording length.

Stop a Record

- 1 Press STOP to stop recording.**

Audio Mode for Recording

With the proper audio mode setting, your unit can:

- Record and playback MTS stereo broadcast (main language) in stereo Hi-Fi. Stereo sound is recorded on the left and right audio tracks and on the video portion of a tape.
- Record and playback a monaural broadcast (main language) or SAP (Secondary Audio Program, usually in a second language) on the Hi-Fi tracks for better quality monaural sound.
- Playback non-Hi-Fi tapes in monaural.

Choose audio mode to match recording type.

- 1 Press AUDIO repeatedly to select the audio mode according to the type of broadcast to be recorded.**

- The Audio mode selected stays in effect until it is changed.
- Refer to "MTS Broadcast / TV Stereo System" on page 21.



- 2 See the "Record On a Tape" section to do a recording.**

Notes:

- Refer to "Audio Mode for Playback" on page 33.
- Only tapes recorded in Hi-Fi stereo will playback with true stereo sound. Standard stereo tapes will playback with monaural sound.
- To listen to Hi-Fi stereo playback, the unit AUDIO (L/R) jacks must be connected to a stereo amp and speakers.
- There may be a difference in audio level between Hi-Fi and normal audio playback.

Timer Recording

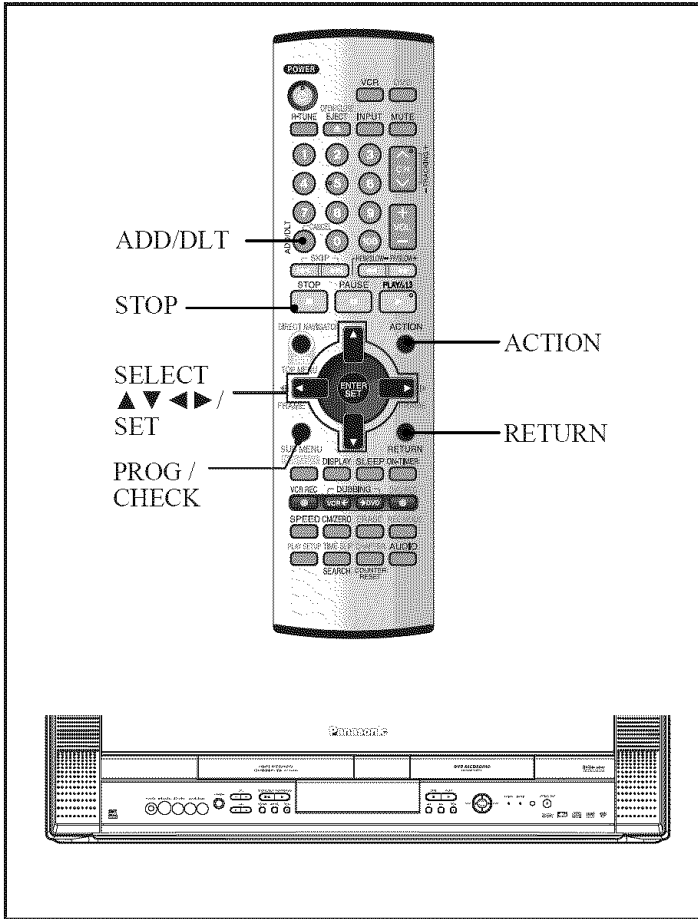

Set up to 8 Programs

You can set up to 8 programs to be recorded while you are away.

- 1 Press **PROG/CHECK** to display **SET TIMER PROGRAM** screen.
- 2 Press **◀▶** to select "VCR."
 • If clock was not set correctly, "PLEASE SET CLOCK BY PRESSING ACTION KEY" is displayed. See pages 17-18 to set the clock.
- 3 Press **SET** to display screen.
 • If a program is already in memory, press **▲▼**, and **SET** to select an unused program number.

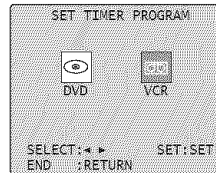

- 4 Press **▲▼** to select and **SET** or **◀▶** to set the recording **DATE**.

- 1~31 = One time
- DAILY (day) = Monday~Friday
- WEEKLY (SU~SA) = Same time once a week

P	DT	START	STOP	CH	SPD
1	---	---	---	---	---
2	---	---	---	---	---
3	---	---	---	---	---
4	---	---	---	---	---

SELECT: ▲▼ SET: SET
END: RETURN

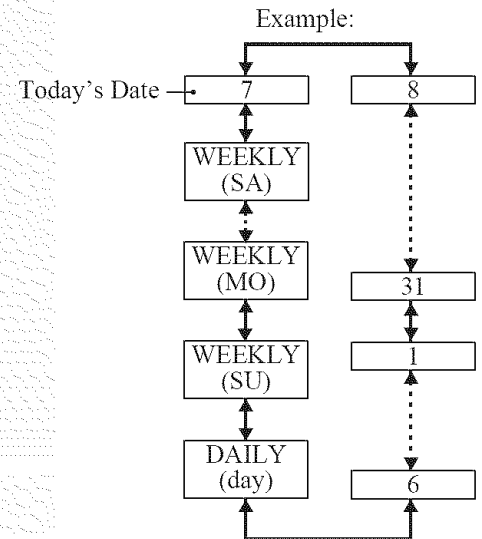

Repeat step 4 to set:

- Start time, stop time
- Channel (or LINE for outside source)
- Speed (SP, EP)

- 5 Press **RETURN** to end the program. To Enter More Programs, press **▲▼** to select and **SET** to set a blank program number, and then repeat step 4.

P	DT	START	STOP	CH	SPD
1	10	9:00a	12:00p	08	SP
2	---	---	---	---	---
3	---	---	---	---	---
4	---	---	---	---	---

SET COMPLETED
CANCEL: ADD/HLT SET: SET
SELECT: ▲▼ END: RETURN

- 6 Press **RETURN** to exit this mode.
 • If you're using a cable box, make sure that it is tuned to the desired channel and the power is left on for timer recording.

Note:

- If the timer recording times of the Disc (DVD-RAM, DVD-R) side and VCR side overlap, the one with the earliest recording start time will have priority. If the start times are the same, the Disc side will have priority.

Review, Replace or Clear Program Contents : (Recording is not in progress)

- 1 Press PROG/CHECK to display SET TIMER PROGRAM screen.
- 2 Press ◀▶ to select "VCR."

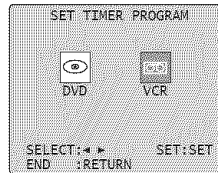

- 3 Press SET to display screen.
- 4 Press ▲▼ to select the desired program.

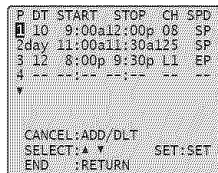

■ To Replace program...

- a. Press SET to display.
- b. Press ▲▼ to select and press SET or ◀▶ to set new program contents.
- c. Press RETURN.

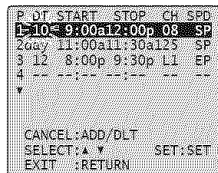

■ To Clear program...

Press ADD/DLT.

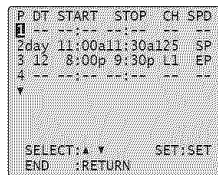

- 5 Press RETURN to exit this mode.

Notes:

- 2 minutes before Timer recording is performed, "PLEASE PREPARE FOR VCR TIMER REC" appears. Be sure a cassette with record tab is loaded and the unit is in Stop mode.
- If the start times of two programs overlap, the lower numbered program will have priority.
- If the start time for a Timer Recording comes up during a normal recording or One Touch Recording (page 29), the Timer Recording will not be performed.
- If there is a power interruption of more than one minute, the recording may not be performed or continued.
- If "INCOMPLETE" appears after all items have been set, check all entries and make necessary corrections.

Cancel a Timer Recording: (Recording is in progress)

- 1 Hold down STOP for a few seconds to cancel the Timer Recording.
 - Any future daily or weekly recordings will be performed as programmed.

Playing VCR

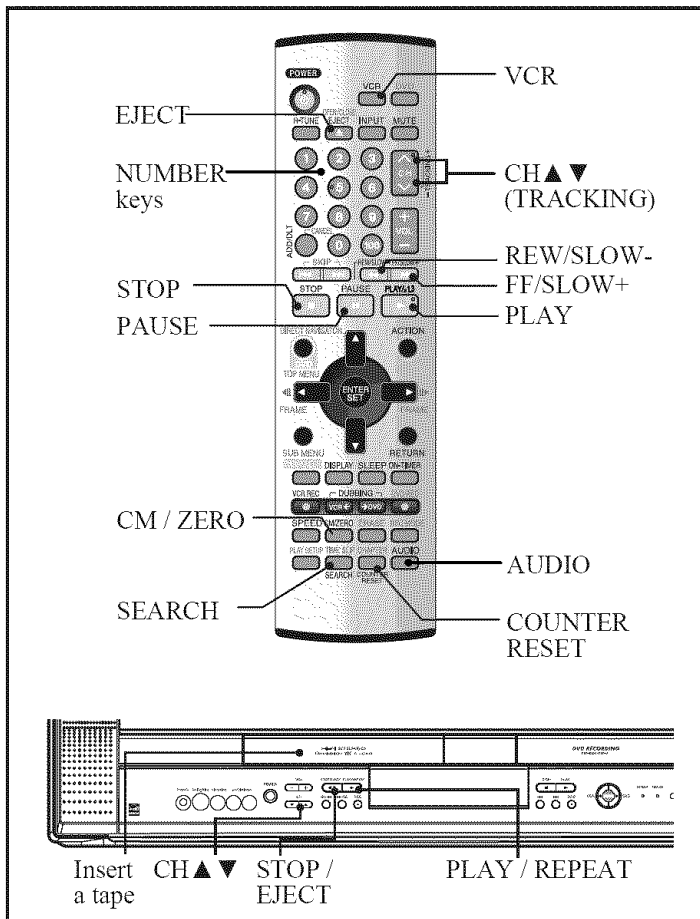

■ Slow Motion picture

- Press PAUSE.
- Press FF/SLOW+ (increases speed) or REW/SLOW- (decreases speed) in Still mode.
- Press PLAY to release.

■ Frame by Frame picture

- Press PAUSE.
- Press PAUSE in Still mode.
- Press PLAY to release.

Notes:

- These features work best in EP mode.
- After 3 minutes in Still or Slow mode, unit stops to protect the tape and the video heads.

Stop a Tape

Press STOP.

■ Rapid Rewind tape

Press REW/SLOW- in Stop mode.
Rewinds a T-120 tape in approx. 1 minute.

■ Rapid Fast forward tape

Press FF/SLOW+ in Stop mode.

■ Eject tape

Press EJECT on the Remote Control or STOP/EJECT on the unit.

Playback a Tape

1 Insert a tape with record tab. (p.28)

- The unit power comes on automatically.

2 Press PLAY to play a tape.

- If tape has no record tab (see page 6), auto play begins.

Note:

- To reduce picture noise, see "Manual Tracking Control" on page 34.

■ Forward/Reverse scene search

- Press FF/SLOW+ or REW/SLOW-.
- Press PLAY to release.

After search has begun, each additional press of FF or REW changes speed.

- FF and REW search speed may vary depending on current tape position.
- After 10 minutes in search mode, unit returns to Play mode to protect the tape and the video heads.

■ Still (Freeze) picture

- Press PAUSE.
- Press PLAY to release.

Repeat Play

Set to see a recording over and over.

> REPEAT
REPEAT ON

■ To turn "ON"

Press PLAY/REPEAT on the unit repeatedly in Play mode to select "REPEAT ON."

■ To turn "OFF"

Repeat above to select "REPEAT OFF."

Notes:

- Playback repeats when tape end is reached or an unrecorded portion longer than 30 seconds is detected.
- For repeat play in disc mode, see pages 55-56.

Zero Search

To quickly return to a specific tape counter location.

- 1 Press **COUNTER RESET** during playback to display the Counter.
- 2 While (counter is displayed), Press **COUNTER RESET** at the desired position to reset to "0:00.00."

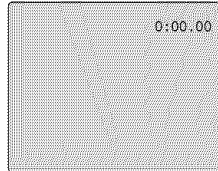

- 3 Continue to record, playback etc.
- 4 Press **STOP**.
- 5 Press **CM/ZERO** in Stop mode to start **ZERO SEARCH**.
 - Unit will go into FF or REW mode and stops at the last point the Counter was set to 0:00.00.

Audio Mode for Playback

Choose the type of sound track for playback.

- 1 See the "Playback a Tape" section on page 32 to playback the tape.
- 2 Press **AUDIO** repeatedly (each press within 5 seconds) to select desired mode.
 - Select "HIFI (L/R)," to listen to a regular Hi Fi Stereo recording. Select "HIFI (L)" or "HIFI (R)" to listen only to the left or right channel of a stereo recording. This is commonly used for Karaoke, music on one channel and vocal on the other. Select "NORMAL" for linear stereo playback from a recorded tape with Hi Fi disabled.
 - This screen appears when you press AUDIO during playback.

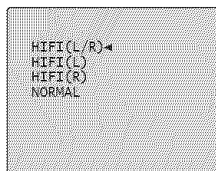

Index Search

Search System is ...

Each time a recording is made, an invisible index mark is placed on the tape. When timer recordings are made, program index and information are also included. These index marks can be used to access or scan recordings.

Go directly to the desired recording.

- 1 Press **SEARCH** in Playback or Stop mode to display **INDEX SEARCH** screen, and then press **NUMBER** keys to select the recording number.

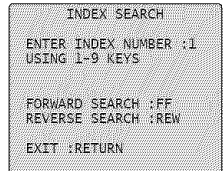

- 2 Press **FF** or **REW** to start search.

Example 1:

To go to rec. 2 from rec. 4, enter 3 and press REW.

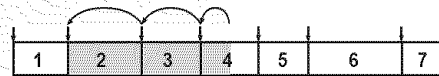

Example 2:

To go to rec. 6 from rec. 2, enter 4 and press FF.

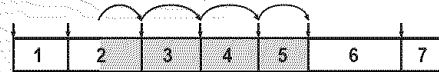

NOTE: ↓ indicates start points of each recording.

Note:

- If Index Search is started very close to an index mark, that index mark may not be counted in the search.

- 3 Play begins at search end. To search forward or back 1 index, press **FF** or **REW** while screen below is displayed (10 seconds).

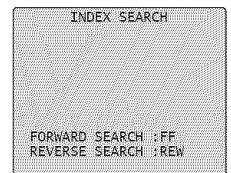

- To cancel, press **STOP**.

Commercial Skip

By pressing CM/ZERO in Playback mode you can skip over 1, 2, or 3 minutes of recorded tape as desired.

- 1 Press CM/ZERO repeatedly to select skip time in Playback mode.

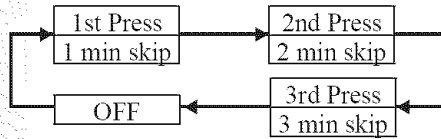

Note:

- No indication appears.

Auto Playback

Insert a tape in Power off mode.
Power turns on, → Play.

Note:

- Playback begins if tape has no record tab.

Auto Rewind

(except for Recording)

Tape reaches its end
Rewind, → Stop.

Playback Auto Eject

(Repeat Play must be "OFF")

Tape with no record tab reaches its end
Rewind, → Stop, → Eject.

Digital Auto Tracking

Continuously analyzes the signal and adjusts for optimum picture quality.

Manual Tracking Control

Use during Playback and Slow Motion mode to reduce picture noise. Press CH ▲▼ on the Remote Control or the unit until the picture clears up. To return to Auto Tracking, press POWER off, then on again a few seconds later.

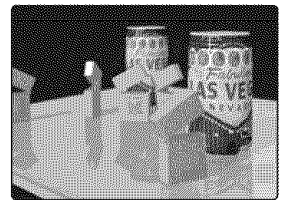
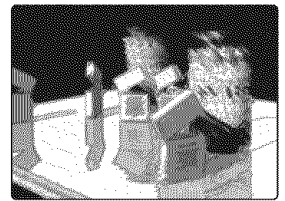

V-Lock Control

In Still mode, CH ▲▼ operate as a V-Lock control to reduce jitter.

V-Chip Control Features

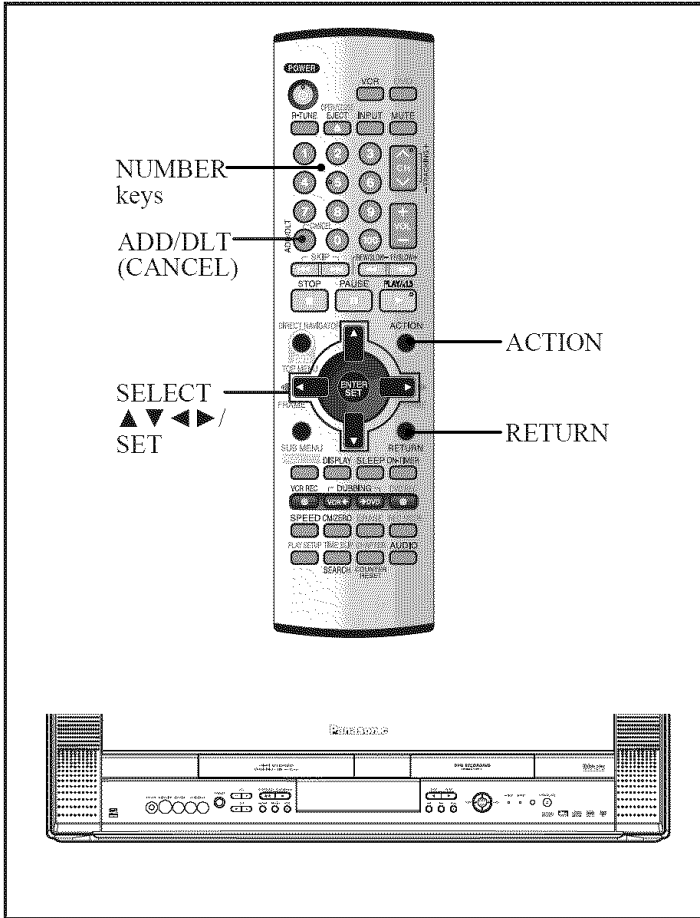

V-Chip Control Feature is...

This unit has a built-in V-Chip Control which allows you to block unwanted TV usage based on US MOVIES, US TV PROGRAMS Ratings, Canadian English Language Ratings and Canadian French Language Ratings.

Enter Secret Code

A 4-digit code must be entered to view a blocked program or change rating settings.

- 1 Press ACTION to display MAIN MENU.
- 2 Press ▲▼◀▶ to select "LOCK."
- 3 Press SET to display LOCK screen.

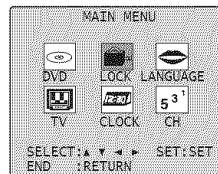

- 4 Press NUMBER keys to enter your secret code.
 - Take care that you are not observed entering the secret code.

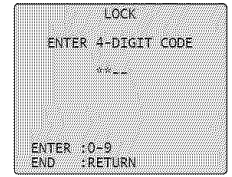

- 5 Enter same code again for confirmation.

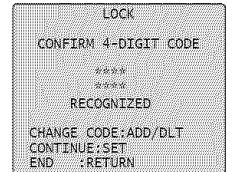

■ To Make Corrections

- a. Press ◀ repeatedly to move the cursor.
- b. Press NUMBER keys to make the correction.

- 6 Press SET to display Ratings menu (see pages 36-38). Or press RETURN twice to exit.

Notes:

- Some rental movies do not include V-Chip data.
- Do not forget your secret code.
- Once ratings are set, restricted tapes or programs cannot be accessed unless the secret code is entered.
- Step 5 not necessary when changing rating.

Changing your secret code

You will need your current code.

- 1 While this OSD (on screen display) is displayed, press ADD/DLT (CANCEL) to clear current code.

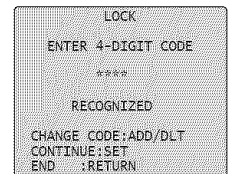

- 2 Enter new secret code.

If LOCK menu is not displayed, perform "Enter Secret Code" steps on page 35.

US MOVIES Ratings

- 1 Press **▲▼** to select "US MOVIES."
• "NEXT PAGE" displays CANADIAN V-Chip settings menu. Please refer to page 37 for more details on Canadian tapes or broadcasts.

- 2 Press **SET** to set "ON" or "OFF."

ON:
V-Chip Control is activated.
OFF:
V-Chip Control is deactivated.

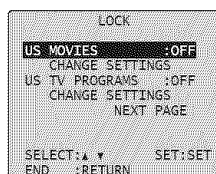

- 3 Press **▲▼** to select "CHANGE SETTINGS."

- 4 Press **SET** to display screen.

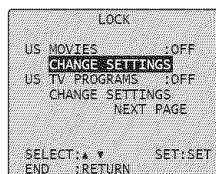

- 5 Press **▲▼** to select "VIEW NR PROGRAMS?."

- 6 Press **SET** to set "YES" or "NO."

■ **NR (Not Rated) PROGRAMS:**
Some movies, such as old movies or foreign movies have no ratings.

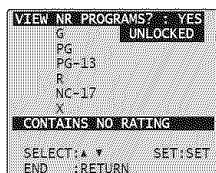

- 7 Press **▲▼** to select and **SET** to set ratings to be blocked.

• See "US MOVIES Ratings Chart" on page 38.

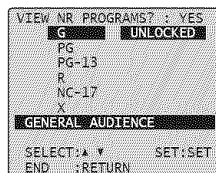

- 8 Press **RETURN** to redisplay LOCK menu and continue with US TV PROGRAMS Ratings. Or, press **RETURN** three times to exit.

US TV PROGRAMS Ratings

- 1 Press **▲▼** to select "US TV PROGRAMS."
• "NEXT PAGE" displays CANADIAN V-Chip setting menu. Please refer to page 37 for more details on Canadian tapes or broadcasts.

- 2 Press **SET** to set "ON" or "OFF."

ON:
V-Chip Control is activated.
OFF:
V-Chip Control is deactivated.

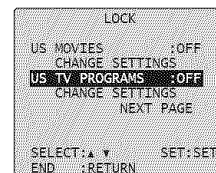

- 3 Press **▲▼** to select "CHANGE SETTINGS."

- 4 Press **SET** to display screen.

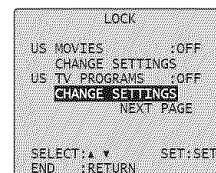

- 5 Press **▲▼** to select "VIEW NR PROGRAMS?."

- 6 Press **SET** to set "YES" or "NO."

■ **NR (Not Rated) PROGRAMS:**

Some TV shows, such as news, sports, weather, bulletins, emergency information have no ratings.

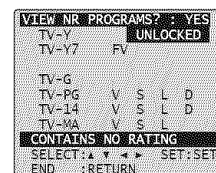

- 7 Press **▲▼** to select and **SET** to set ratings to be blocked.

• See "US TV PROGRAMS Ratings Chart" on page 38.
• You may select from standard TV ratings (chart 1), or customize to a specific content rating (chart 2).
• Ratings highlighted in green will be blocked. Ratings in white letters will not be blocked.

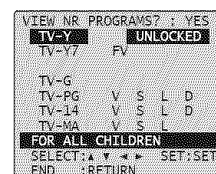

- 8 Press **RETURN** three times to exit this mode.

Canadian English Language Ratings

- 1 Press ▲▼ to select "NEXT PAGE."
- 2 Press SET to display screen.

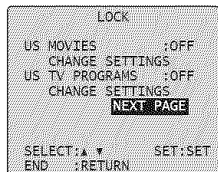

- 3 Press ▲▼ to select "CANADIAN ENGLISH."
- 4 Press SET to set "ON" or "OFF."

ON:
V-Chip Control is activated.

OFF:
V-Chip Control is deactivated.

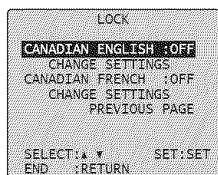

- 5 Press ▲▼ to select "CHANGE SETTINGS."
- 6 Press SET to display screen.

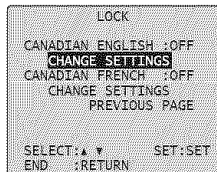

- 7 Press ▲▼ to select "VIEW E PROGRAMS?."
- 8 Press SET to set "YES" or "NO."

■ **E (Exempt) PROGRAMS:**
Some TV shows, such as news, sports, weather, bulletins, and emergency information have no ratings.

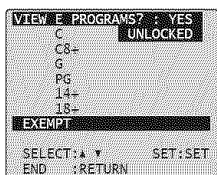

- 9 Press ▲▼ to select and SET to set ratings to be blocked.

• See "Canadian English Language Ratings Chart" on page 38.

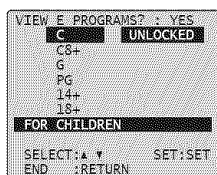

- 10 Press RETURN to redisplay LOCK menu and continue with Canadian French Language Ratings. Or, press RETURN three times to exit.

Canadian French Language Ratings

- 1 Press ▲▼ to select "NEXT PAGE."
- 2 Press SET to display screen.

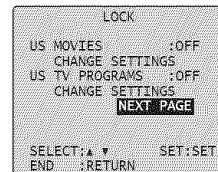

- 3 Press ▲▼ to select "CANADIAN FRENCH."
- 4 Press SET to set "ON" or "OFF."

ON:
V-Chip Control is activated.

OFF:
V-Chip Control is deactivated.

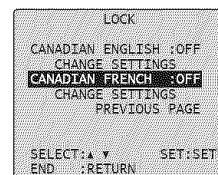

- 5 Press ▲▼ to select "CHANGE SETTINGS."
- 6 Press SET to display screen.

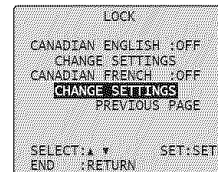

- 7 Press ▲▼ to select "VIEW E PROGRAMS?."
- 8 Press SET to set "YES" or "NO."

■ **E (Exempt) PROGRAMS:**
Some TV shows, such as news, sports, weather, bulletins, and emergency information have no ratings.

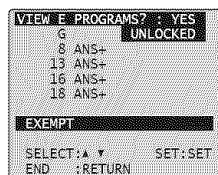

- 9 Repeatedly press ▲▼ to select and SET to set ratings to be blocked.

• See "Canadian French Language Ratings Chart" on page 38.

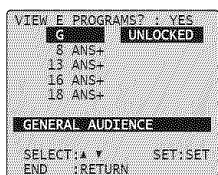

- 10 Press RETURN three times to exit this mode.

US MOVIES Ratings Chart

G	GENERAL AUDIENCE: All ages admitted.
PG	PARENTAL GUIDANCE: Some material may not be suitable for children.
PG-13	PARENTS CAUTIONED: Some material may be inappropriate for children under 13.
R	RESTRICTED: Children under 17 must be accompanied by a parent or adult.
NC-17	OVER AGE 17 ONLY: No one 17 and under admitted.
X	ADULTS ONLY:

US TV PROGRAMS Ratings Chart

Chart 1

TV-Y	FOR ALL CHILDREN: Content specifically geared to young viewers ages 2-6.
TV-Y7	FOR AGE 7 AND OLDER: May contain mild physical or comedic violence which may frighten children under 7.
TV-G	GENERAL AUDIENCE: Contains little or no violence, strong language, or sexual dialogue or situations.
TV-PG	PARENTAL GUIDANCE: May contain infrequent coarse language, limited violence, some suggestive sexual dialogue and situations.
TV-14	PARENTS CAUTIONED: May contain sophisticated themes, sexual situations, strong language, and more intense violence.
TV-MA	MATURE AUDIENCE: May contain mature themes, profane language, graphic violence, and sexual situations.

Chart 2

FV	Fantasy Violence
V	Violence
S	Sexual Situations
L	Adult Language
D	Sexually Suggestive Dialogue

Canadian English Language Ratings Chart

C	Children
C8+	Children 8 years and older
G	General Audience
PG	Parental Guidance
14+	Viewers 14 years and older
18+	Adult Programming

Canadian French Language Ratings Chart

G	General Audience
8 ANS +	Not recommended for young children
13 ANS +	Programming may not be suitable for children under the age of 13
16 ANS +	Programming is not suitable for children under the age of 16
18 ANS +	Adults only

Blocking Message

<When V-Chip Control is activated>

If a program or movie exceeds the ratings you have set, a message will appear on a black background and sound is muted.

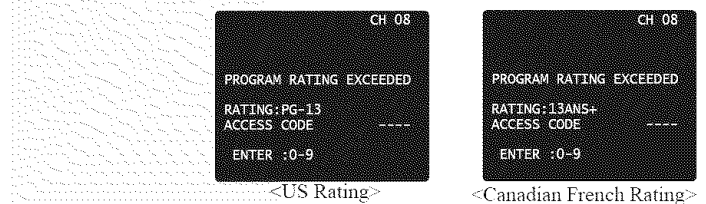

To View a Blocked Program/Movie

■ Temporarily Deactivate V-Chip Control

Press NUMBER keys to enter your secret code in the Blocking Message screen.

- V-Chip Control is reactivated when power is turned off or power failure occurs.

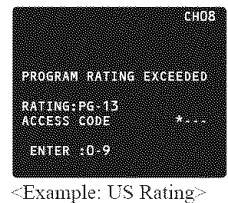

<Example: US Rating>

■ Deactivate V-Chip Control

- 1 Enter your secret code.
(See page 35.)

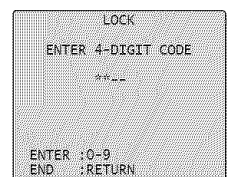

- 2 Then, set US MOVIES and/or US TV PROGRAMS and/or CANADIAN ENGLISH LANGUAGE and/or CANADIAN FRENCH LANGUAGE to "OFF" using ▲ ▼ and SET. (Ratings set on pages 35-37 are retained and will be in effect when V-Chip Control is activated again.)

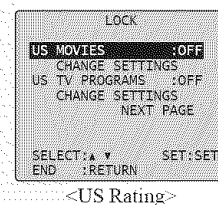

<US Rating>

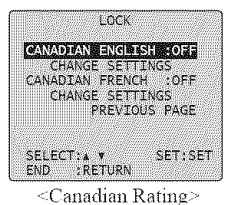

<Canadian Rating>

Display Feature

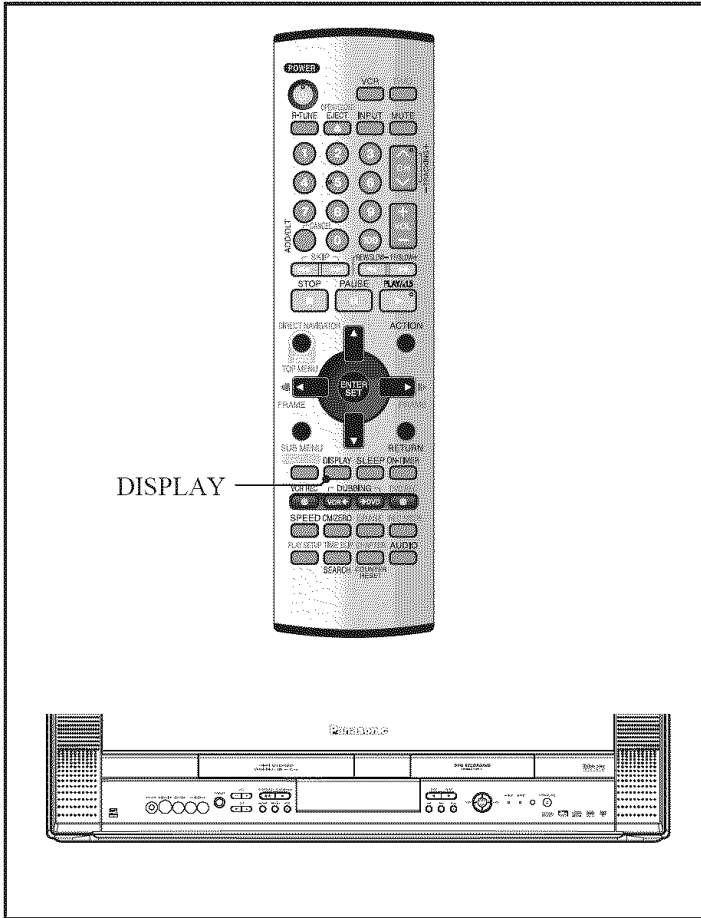

TV/VCR Status & Clock Display

- 1 Press **DISPLAY** to display or remove the overlay.

A few seconds.

- 1 Tape Function Status
- 2 Active Indicator Shows media being displayed.
- 3 Disc Function Status
- 4 Receivable Broadcast Types (See page 21.)
- 5 Current Time
- 6 Channel
- 7 Rec Time Remaining (OTR mode only, see page 29.)
- 8 Recording Mode (See page 29.)
- 9 Resume Indicator (Resume mode only, see page 50.)
- 10 Rating Status (See pages 35-38.)

Channel & Function Display

When a function button is pressed (PLAY, FF, etc.) or you change channels, the unit mode or channel number will be displayed.

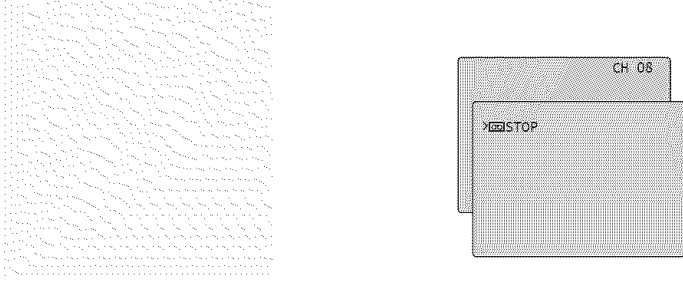

Auto Shut Off

No broadcast signal in TV mode (Only when Weak Signal Display is set to OFF. (See page 19)), or blank tape is played for 5 minutes. **Power turns off.**

Note:

- This feature is canceled if any button is pressed during above conditions.

Blue Screen Display

Whenever a blank section of a tape comes up in Play mode, or when the selected channel has no broadcast signal with the Weak Signal Display Feature set to "OFF" (see page 19), the screen will turn solid blue.

Before using the Disc

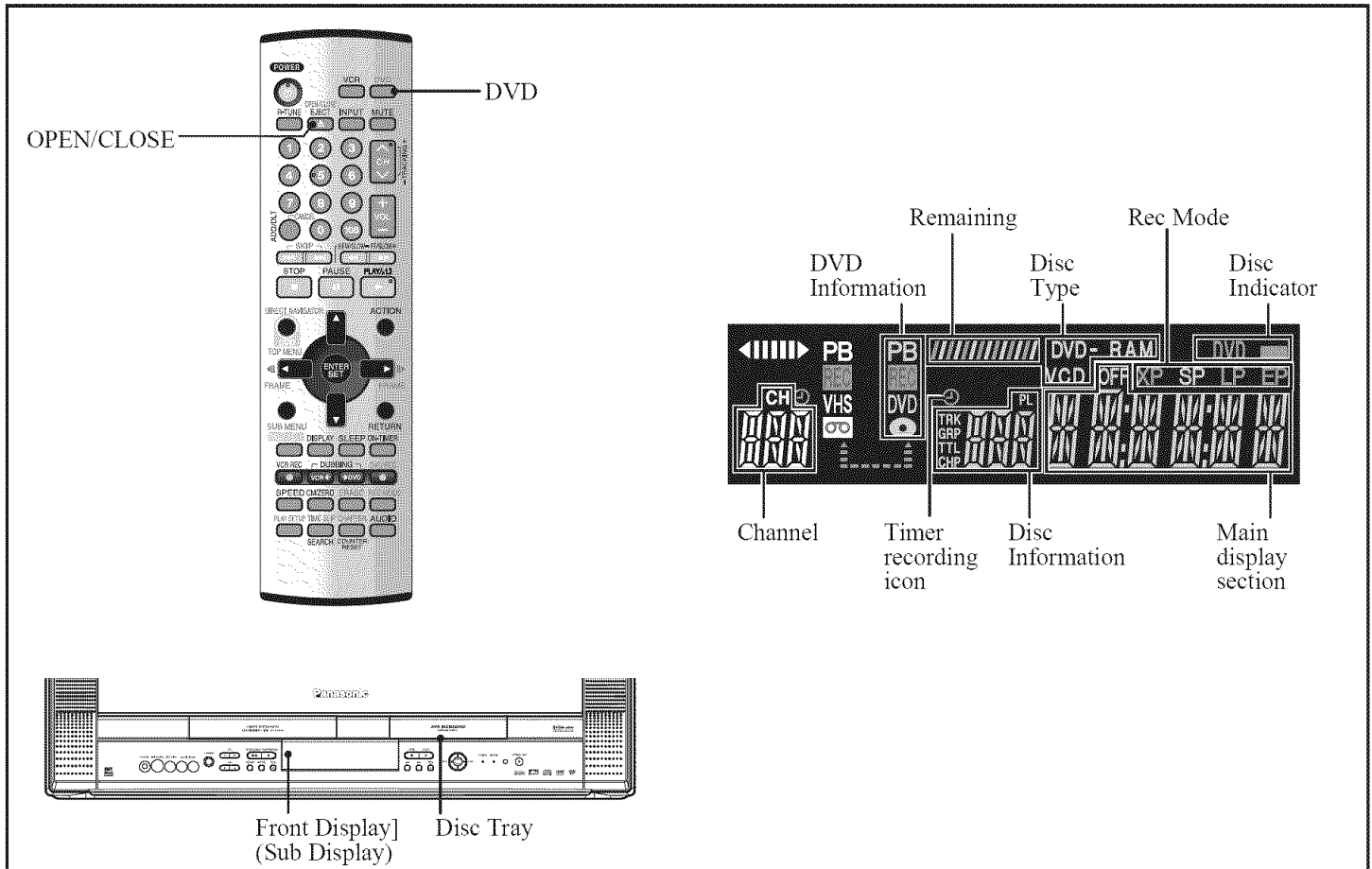

Before using Disc Functions

- 1 Confirm that disc is inserted.
- 2 Press DVD.
 - The indication "DVD" flashes in the Front Display.



- 3 Each operation is carried out.

Inserting a Disc

- 1 Press OPEN/CLOSE on the unit to open the tray and insert a disc.
 - Press the button again to close the tray.

■ Non-cartridge disc

Insert label-up.

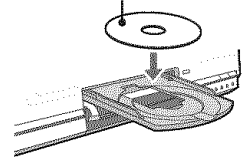

■ Cartridge disc

Insert inside the tray's guide.

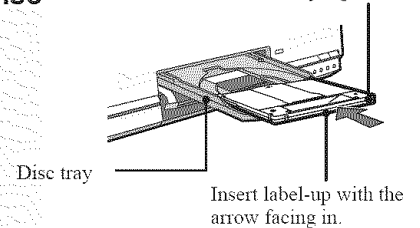

Notes:

- Load double-sided discs so the label for the side you want to record/play is facing up.
- When using 8 cm (3") DVD-RAM, remove the disc from the cartridge and insert it, making sure you align it with the groove.

DVD Functions Windows and Status Messages

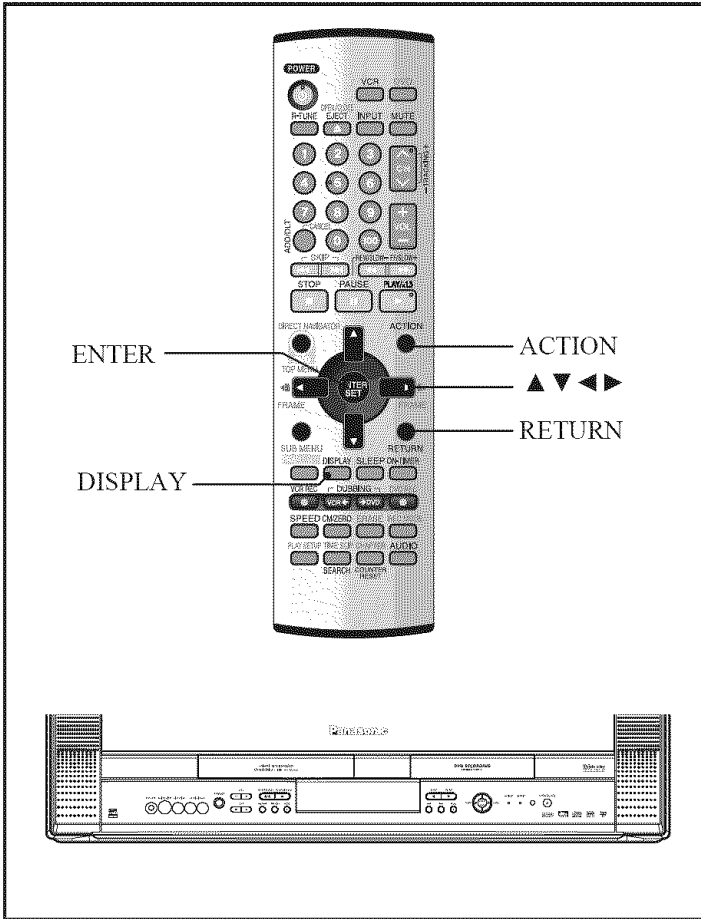

- Press **▲▼◀▶** to select an item and press **ENTER**.
 - Functions displayed depend on the type of disc.

e.g., DVD-RAM

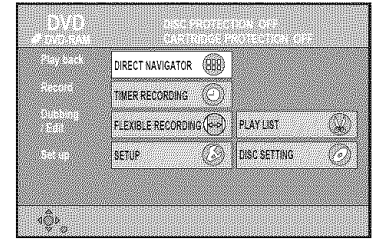

e.g., DVD-RAM

Function	The same operation with Remote Control Button	Pages
DIRECT NAVIGATOR	DIRECT NAVIGATOR	51, 57-59
TIMER RECORDING	PROG/CHECK	46-47
FLEXIBLE RECORDING		45
PLAY LIST		60-62
SET UP		67-69
DISC SETTING		63-65

■ To exit the DVD Functions window

- Press **RETURN**.

Status messages (Disc)

Status messages appear on the television when you operate the unit to show the condition of the unit.

- Press **DISPLAY** in play mode.

- The display changes each time you press the button.

DVD Functions Window

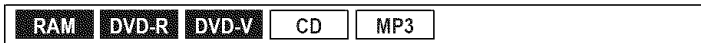

By using the DVD Functions window you may access the main functions quickly and easily.

- Press **ACTION** in Stop mode to display **MAIN MENU**.
- Press **▲▼◀▶** to select "DVD" then press **ENTER**.
 - The DVD Function Window cannot be opened unless the time is set.
 - Opening the DVD Function Window automatically places unit into DVD mode.

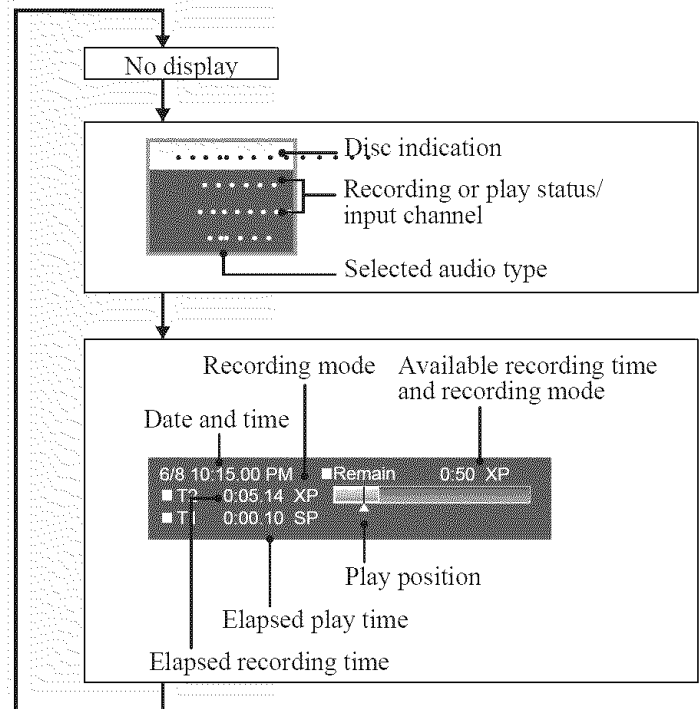
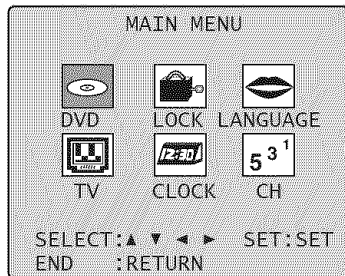

Disc Operation

Function List

Disc Type	Available Function	Page	
RAM	Playback	Start from a selected item (using NUMBER keys)	52
		Fast forward and rewind (Search)	51
		Skip a program or track	51
		Quick View	52
		Slow-motion playback	52
		Frame-by-frame viewing	52
		Skip a minute forward (CM Skip)	51
		Display the television image as a picture-in-picture	52
		Skip the specified time (Time Slip)	52
		Repeat playback	56
		Create Chapters	54
		Select subtitle on/off	55
		Change the audio during play	54
		Erase a program that is being played back	53
		Play with DIRECT NAVIGATOR/PLAY LIST	Play the recorded programs (DIRECT NAVIGATOR)
	Play the created chapters (DIRECT NAVIGATOR)		57
	Play the created play lists (PLAY LIST)		61
	Play the created chapters of Play List (PLAY LIST)		60
	Recording	Timer Recording	46-47
		Flexible Recording	45
		Play from the beginning of the title you are recording (Chasing playback)	48
		Simultaneous Recording and Play	48
		Review the recorded images while recording (Time Slip)	48-49

Disc Type	Available Function	Page	
RAM	Erase or Edit a program with DIRECT NAVIGATOR/PLAY LIST	Erase the selected programs	58
		Display the information about the recorded date/time/channel, etc.	58
		Enter a title name to a program	58
		Protect the title from accidental erasure	58
		Select and erase unnecessary parts of the programs	58
		Change an image to be shown as a thumbnail picture in the Title View	59
		Edit chapters in the DIRECT NAVIGATOR	59
		Create play lists	60-61
		Edit play lists	61-62
		Edit chapters in the PLAY LIST	62
	Disc Setting	Enter the Disc name	63
		Protect the Disc from accidental erasure	63
		Format a Disc	64

• When ⊙ appears on the screen while a button is being pressed, it means that the corresponding operation is prohibited by the unit or the disc.

Disc Type	Available Function	Page	
DVD-R	Playback	Start from a selected item (using NUMBER keys)	52
		Fast forward and rewind (Search)	51
		Skip a program or track	51
		Slow-motion playback	52
		Frame-by-frame viewing	52
		Skip a minute forward (CM Skip)	51
		Repeat playback	56
		Select subtitle on/off	55
		Erase a program that is being played back	53
	Play with DIRECT NAVIGATOR	Play the recorded programs (DIRECT NAVIGATOR)	51, 57
		Recording	
	Recording	Timer Recording	46-47
		Flexible Recording	45
	Erase or Edit a program with DIRECT NAVIGATOR	Erase the selected programs	58
		Display the information about the recorded date/time/channel, etc.	58
		Enter a title name to a program	58
		Change an image to be shown as a thumbnail picture in the Title View	59

Disc Type	Available Function	Page	
DVD-R	Disc Setting	Enter the Disc name	63
		Select whether to show the top menu after finalizing the disc	64
		A process that makes play of a recorded DVD-R possible on equipment that can play such media. (Finalize)	65
DVD-V	Playback	Start from a selected item (using NUMBER keys)	52
		Fast forward and rewind (Search)	51
		Skip a program or track	51
		Slow-motion playback	52
		Frame-by-frame viewing	52
		Repeat playback	56
		Change the sound track language	55
		Select subtitle language	55
Select the angle	55		
CD MP3	Playback	Start from a selected item (using NUMBER keys)	52
		Fast forward and rewind (Search)	51
		Skip a program or track	51
		Play MP3 files recorded on CD-R/RW with a computer.	53
		Repeat playback	56

Recording Television Programs

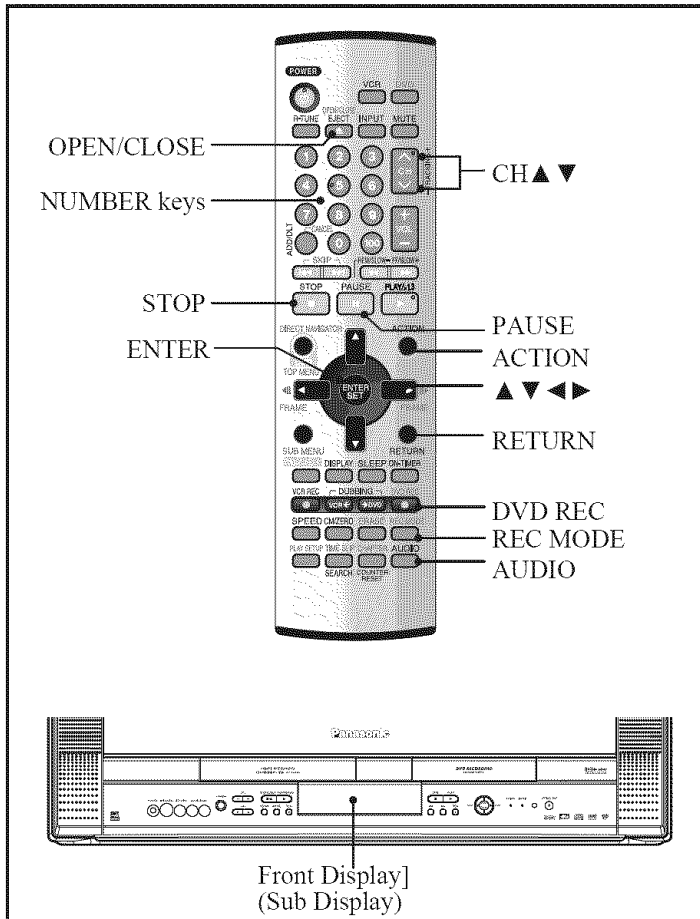

2 Press CH▲▼ or NUMBER keys to select the channel.

e.g., When you select channel 4

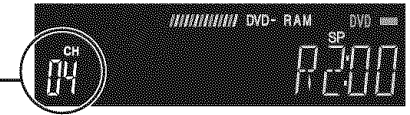

■ To select with the NUMBER keys:

TV Mode (Airwaves)

e.g., 5: [0] → [5]
15: [1] → [5]

CATV Mode (Cable)

e.g., 5: [0] → [5]
15: [1] → [5]
115: [100] → [1] → [5]

3 Press REC MODE to select the recording mode (see next page).

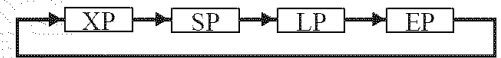

e.g., When you select "XP"



4 Press DVD REC to start recording.



- You cannot change the channel or recording mode during recording.
- You can change the audio being received by pressing AUDIO during recording.

Record On a Disc

RAM DVD-R

- It is not possible to record continuously from one side of a double sided disc to the other. You will need to eject the disc and turn it over.
- When using 8 cm (3") DVD-RAM, remove the disc from the cartridge.
- You can record up to 99 titles on one disc.
- You can record digital broadcasts that allow "one time only recording" when using CPRM (p. 74) compatible DVD-RAM discs. And you cannot record digital broadcasts that allow "one time only recording" when using DVD-R.
- DVD-RAM/DVD-R have limitations on recording (pp. 6-8).
- You cannot record on finalized DVD-R discs.
- Recording will take place on open space on the disc. Data will not be overwritten.
- If there is no space left on the recording disc, you will need to erase unwanted titles (pp. 53, 58) or use a new disc.

Preparation

- Release protection before proceeding:
 - Cartridge (p. 7) **RAM**
 - Disc (p. 63) **RAM**

1 Press OPEN/CLOSE on the unit to open the tray and insert a disc. (p. 40)

- Press the button again to close the tray.
- **RAM** When using a DVD-RAM for the first time with this unit, format it to ensure accurate recording. ("Format Disc" on page 64.)

■ To specify a time to stop recording

During recording

Press DVD REC on the unit or the Remote Control to select the recording time.

Each time you press the button:

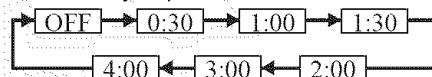

- This does not work during timer recordings (pp. 46-47) or while using Flexible Recording (p. 45).
- Recording stops and the set time is cleared if you press STOP.
- The set time is cleared if you change the recording mode or channel while recording is paused.

■ To stop recording

Press STOP.

- Recorded as 1 title until the position where stopped.
- **DVD-R** It takes about 30 seconds for the unit to complete recording management information after recording finishes.

■ To pause recording

Press PAUSE.

Press again to restart recording.

• When  appears on the screen while a button is being pressed, it means that the corresponding operation is prohibited by the unit or the disc.

Recording modes and approximate recording times

Depending on the content being recorded, the recording times may become shorter than indicated.

(Unit: hour)

Recording Mode \ Disc	DVD-RAM		DVD-R (4.7 GB)
	Single-sided (4.7 GB)	Double-sided (9.4 GB)	
XP (High quality)	1	2* ¹	1
SP (Normal)	2	4* ¹	2
LP (Long play)	4	8* ¹	4
EP (Extra long play)	8 (6* ²)	16* ¹ (12* ¹ * ²)	8 (6* ²)

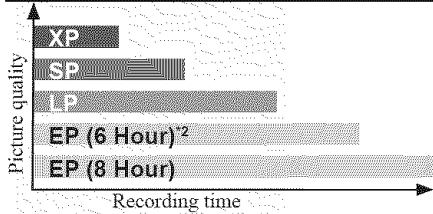

*¹ Rec Time of double-sided disc is sum total of both sides of disc.

*² When "Recording time in EP mode" (p. 68) is set to "EP (6 Hour)" in the SETUP menu. The sound quality is better when using "EP (6 Hour)" than when using "EP (8 Hour)".

Note:

- When recording to DVD-RAM using "EP (8 Hour)" mode, play may not be possible on DVD players that are compatible with DVD-RAM. In this case use "EP (6 Hour)" mode.

FR (Flexible Recording Mode) (See right.)

The unit automatically selects a recording rate between XP and EP (8 Hour) that will enable the recordings to fit in the available recording time on the disc with the best possible recording quality.

- You can set when programming timer recordings.
- All the recording modes from XP to EP appear in the display.

Selecting audio to record

RAM DVD-R

Choose audio mode to match recording type.

- 1 Press **AUDIO** repeatedly to select the audio mode according to the disc of broadcast to be recorded.

- The Audio mode selected stays in effect until it is changed.
- Refer to "MTS Broadcast / TV Stereo System" on page 21.

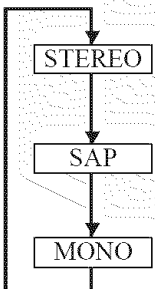
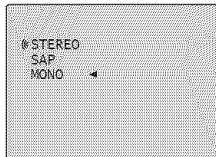

Main audio (stereo)

- If the broadcast is "Mono + SAP" audio will be monaural even if you select Stereo mode.

Secondary audio program (SAP)

- If recorded in SAP mode, main audio is also recorded.

Main audio (monaural)

- Select "Mono" if reception is poor during a stereo broadcast.

- 2 See the "Recording television programs" section to do a recording.

Flexible Recording (FR)

RAM DVD-R

The unit calculates a recording rate that enables the recording to fit in the time you set (within the remaining time on the disc) with the best picture quality.

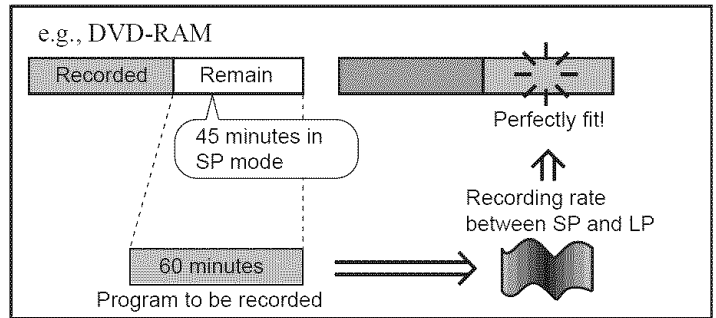

- 1 Press **ACTION** to display MAIN MENU and select "DVD" then press **ENTER**. (P.41)

- 2 Press **▲▼◀▶** to select "FLEXIBLE REC" and press **ENTER**.

- Functions displayed depend on the type of disc.

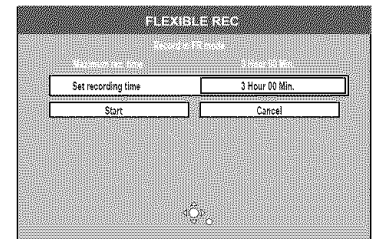

- 3 Press **◀▶** to select "Hour" and "Min." and press **▲▼** to set the recording time.

- You can also set the recording time with the NUMBER keys.
- Maximum recording time is 8 hours.

- 4 Press **▲▼◀▶** to select "Start" and press **ENTER** to start recording.

- Recording starts.
- The recording mode becomes FR mode.

Note:

- It is not possible to change channel or recording mode while Flexible Recording is paused.

- To exit the screen without recording Press **RETURN**.

- To stop recording partway Press **STOP**.

Timer Recording

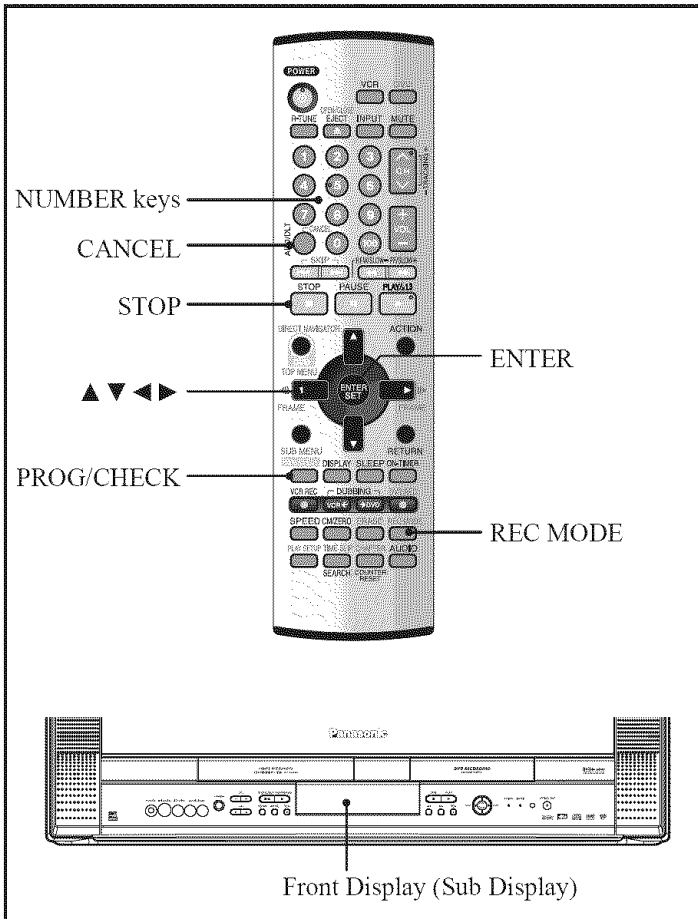

Set up to 16 Programs

RAM DVD-R

Caution for Timer recording

- Timer recording automatically starts at the set time.
- Timer recording can be started whether the unit is turned on or off. When the unit is turned off, the sound and the video cannot be outputted to the TV.

Preparation

- Release protection before proceeding:
 - Cartridge (p. 7) **RAM**
 - Disc (p. 63) **RAM**
- Insert a disc (p. 40) and confirm there is sufficient empty space for recording on it (p. 41).

You can enter up to 16 programs up to a month in advance. (Each daily or weekly program is counted as one program.)

- When connecting a cable TV box or satellite receiver, select the channel on the cable TV box or satellite receiver before timer recording starts.

Add a program

- Press **PROG/CHECK** to display **SET TIMER PROGRAM** screen.
- Press **◀▶** to select "DVD", then press **ENTER**.

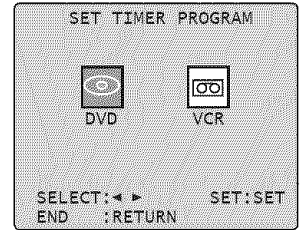

- Press **▲▼** to select "New Timer Program," then press **ENTER**.

Highlighted line is ready for programming.

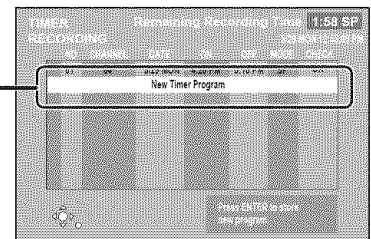

- Press **▶** to move through the items and change the items with **▲▼**.

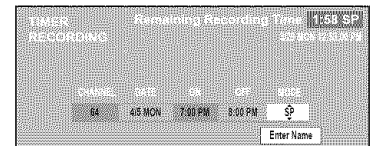

- Press and hold **▲▼** to alter the Start (Start time) and Stop (Finish time) in 30-minute increments.
- You can also set CHANNEL (Program Position), DATE (See below), ON (Start time), and OFF (Finish time) with the NUMBER keys.
- You can also press **REC MODE** to change the recording mode.

Date



- Enter Name:** Press **◀▶** to select "Enter Name" and press **ENTER**. (p. 66)

• When  appears on the screen while a button is being pressed, it means that the corresponding operation is prohibited by the unit or the disc.

5 Press ENTER.

Check to make sure “OK” is displayed.

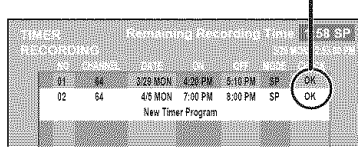

- Repeat steps 3-5 to program other recordings.

6 Press RETURN.

- “” lights on the Front Display to indicate timer recording standby has been activated.

■ To cancel recording when recording has already begun

Hold down STOP for a few seconds.

Notes:

- “” flashes when the unit cannot go to timer recording standby (e.g., a recordable disc is not in the disc tray). Check the disc carefully.
- When you program successive timer recordings to start immediately one after the other, the unit cannot record the part at the beginning of the later programs (a few seconds when recording with DVD-RAM and approximately 30 seconds when recording with DVD-R).
- If you set DST (Daylight Saving Time) to On when manually setting the clock (pp. 17-18), timer recording may not work when summer switches to winter and vice versa.
- When the unit is carrying out a timer recording:
 - You may utilize playback.
- When the disc is not inserted, the disc is full or a non-recordable disc is inserted, the warning message appears because Timer Recording is disabled.
- During Timer Recording, dubbing and editing are disabled.
- Timer recordings are automatically placed in order of DATE → ON (Start Time).
- If timer recording times overlap, the program with the earliest start time is recorded first. The overlapped portion of the later program will not be recorded.





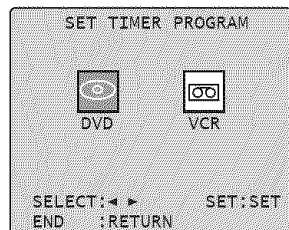

Check, change or delete a program

1 Press PROG/CHECK to display SET TIMER PROGRAM screen.

2 Press to select “DVD”, then press ENTER.



Icons

-  This program is currently recording.
-  The times overlap those in another program. Recording of the program with the later start time starts when the earlier program finishes recording.
-  You stopped a weekly or daily timer recording. The icon disappears the next time the timer starts recording.
-  The disc was full so the program failed to record.
-  The material was copy-protected so it was not recorded.
-  The program did not complete recording because the disc is dirty or some other reason.

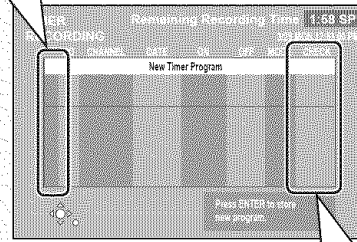





Message displayed in the CHECK line

- OK:** Displayed if the recording can fit in the remaining space.
- **(Date):** For recordings made daily or weekly, the display will show until when recordings can be made (up to a maximum of one month from the present time) based on the time remaining on the disc.
- ! :** It may not be possible to record because:
- the disc is write-protected
 - there is not enough space left
 - the number of possible titles has reached its maximum.

■ To change a program

Press   to select the program and press ENTER.

Press   to move through the items and change the items with  , then press ENTER.

■ To delete a program

Press   to select the program and press CANCEL.

- You cannot delete programs that are currently recording.

■ To put the unit on timer recording standby

Press RETURN.

- “” lights on the Front Display to indicate timer recording standby has been activated.

3 Press RETURN.

- The timer recording list disappears.

Notes:

- Programs that failed to record are displayed gray. They are automatically deleted from the timer recording list at 4 a.m. two days later.
- During timer recording, you can change the end time as long as the recording mode is not “FR”.

Various Recording

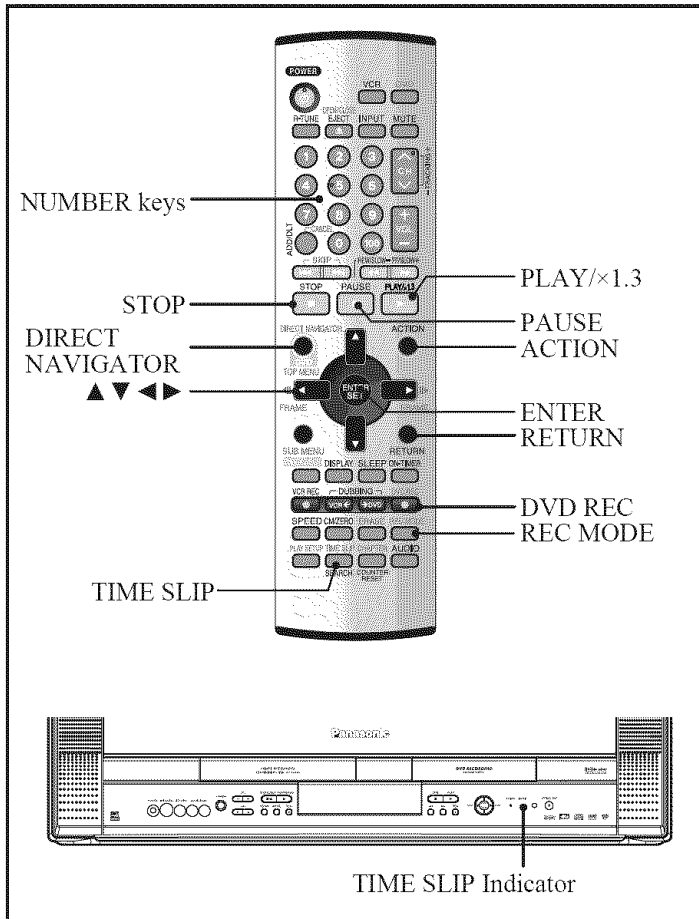

Simultaneous Recording and Play

RAM

You can start play of the title you are recording or play a title previously recorded.

- 1 Press **DIRECT NAVIGATOR** while recording or timer recording.
- 2 Press **▲▼◀▶** to select a title and press **ENTER**.
 - TIME SLIP Indicator on the unit lights.

e.g.:

You want to watch the movie you recorded yesterday (title 07) while recording sport (title 08). Title 07 is played back while title 08 is being recorded.

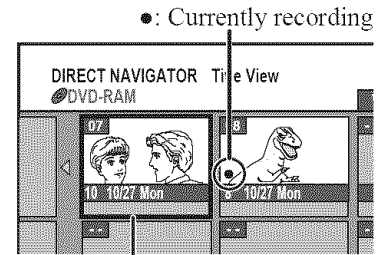

Selecting title 07

- **To stop play**
Press STOP.
- **To exit the DIRECT NAVIGATOR screen**
Press DIRECT NAVIGATOR.
- **To stop recording**
First, press STOP to stop play. Then, exit DIRECT NAVIGATOR, wait 2 seconds, and press STOP again.
- **To stop timer recording**
First, press STOP to stop play. Then, exit DIRECT NAVIGATOR. Wait 2 seconds, Hold down STOP for a few seconds.

Notes:

- Sound is not output while fast-forwarding.
- During simultaneous recording and play, you cannot edit or erase with the Direct Navigator or play lists.
- If you start play while the unit is on standby for timer recording, recording starts when the time you set is reached.

Playing while you are recording

Preparation

- Release protection before proceeding:
 - Cartridge (p. 7) **RAM**
 - Disc (p. 63) **RAM**

Chasing playback

RAM

You can start play from the beginning of the title while continuing to record it.

- 1 Press **PLAY/1.3** while recording or timer recording.
 - TIME SLIP Indicator on the unit lights.

- **To stop play**
Press STOP.
- **To stop recording**
Press STOP. Wait 2 seconds, press STOP again.
- **To stop timer recording**
Press STOP. Wait 2 seconds, Hold down STOP for a few seconds.

Notes:

- Sound is not output while fast-forwarding.
- Play cannot be started until at least 2 seconds after recording starts.

Time Slip (Playing while you are recording)

RAM

You can play the title being recorded to check that it is being recorded correctly. You can also check parts that were recorded previously.

- 1 Press **TIME SLIP** while recording or timer recording.
 - TIME SLIP Indicator on the unit lights.
 - Play starts from 30 seconds previous to that moment. What is currently being recorded appears as a picture-in-picture and you will hear the playback audio.
 - Time Slip becomes unavailable if any V-Chip setting is made in the LOCK item of the Main Menu.

Play starts from 30 seconds previous.

The current recording images.

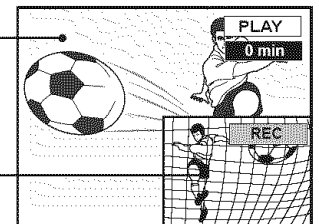

• When  appears on the screen while a button is being pressed, it means that the corresponding operation is prohibited by the unit or the disc.

2 Press ▲▼ to select the time and press ENTER.

- The time indicator will go off after about 5 seconds, but will turn on again when you set the indicator.
- Press ▲▼ to alter in 1-minute units. Press and hold ▲▼ to alter in 10-minute units.

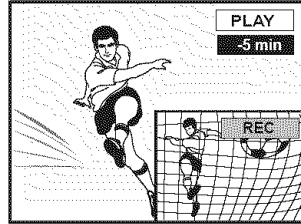

To show the play images in full

Press TIME SLIP.

- Press TIME SLIP to return to the picture-in-picture screen.

Note:

- The image on the small screen may be distorted or flicker depending on the scene. However, this does not affect the image recorded.

To stop play

Press STOP.

To stop recording

Press STOP. Wait 2 seconds, press STOP again.

To stop timer recording

Press STOP. Wait 2 seconds, Hold down STOP for a few seconds.

Recording from a video cassette recorder

RAM DVD-R

Preparation

- Connect a video cassette recorder to this unit's input terminals.

Notes:

- When recording using this unit's input terminals, only the sound received at the time of recording will be recorded. As long as secondary audio that is recorded on the video cassette is not output on the unit in play, it is not recorded.

1 Press INPUT to select the input channel for the equipment you have connected in Stop mode.

2 Press REC MODE to select the recording mode (XP, SP, LP or EP).

- Using Flexible Recording (p. 45), you can save content of a video cassette to 1 disc with the best possible quality of recording without wasting disc space.

3 Start play on the other equipment.

4 Press DVD REC.

- Recording starts.

To skip unwanted parts

Press PAUSE to pause recording. (Press again to restart recording.)

To stop recording

Press STOP.

Almost all videos and DVD software on sale have been treated to prevent illegal copying. Any software that has been so treated cannot be recorded using this unit.

e.g., Connecting the L2 input terminals

This unit

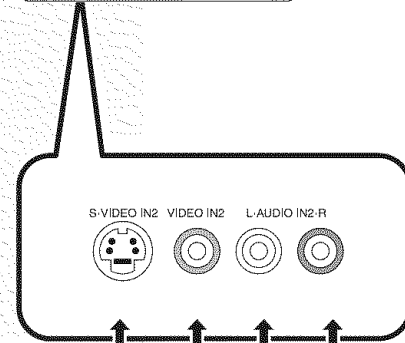
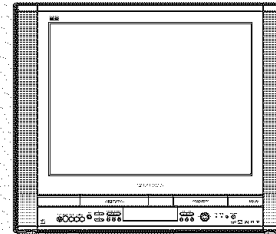

Yellow White Red

S-Video cable*

Audio/Video cable

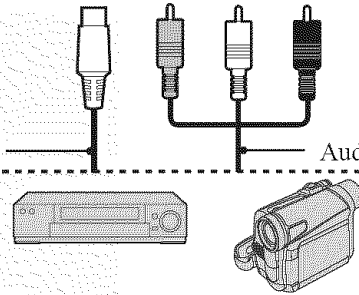

Other video equipment

If the audio output of the other equipment is monaural, connect to L/MONO.

* The S-VIDEO terminal achieves a more vivid picture than the VIDEO terminal.

Playing Discs

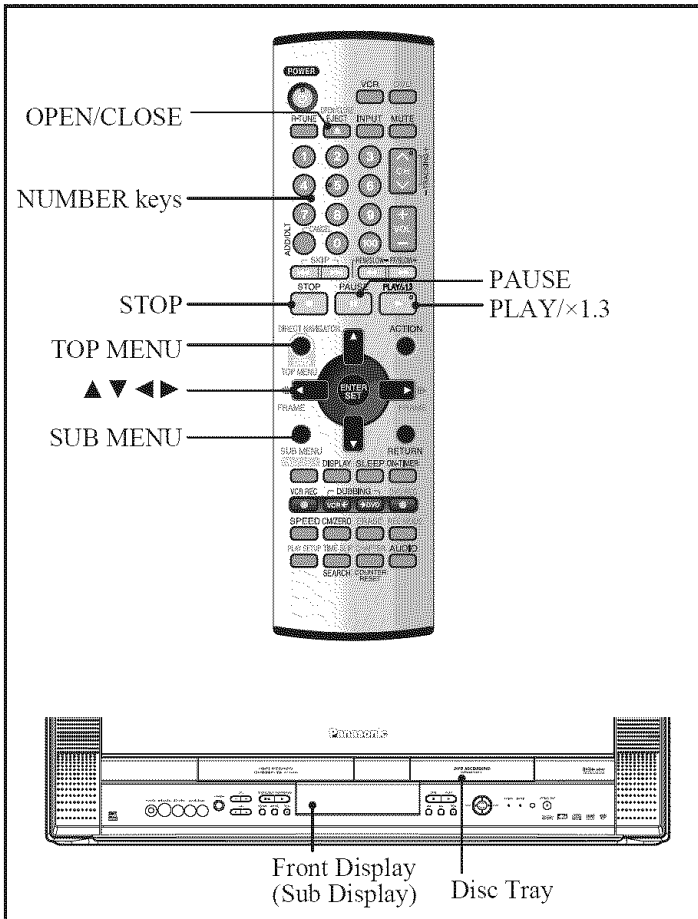

Playing discs procedure

RAM DVD-R DVD-V CD MP3

- It is not possible to play continuously from one side of a double sided disc to the other. You will need to eject the disc and turn it over.
- When using 8 cm (3") DVD-RAM, remove the disc from the cartridge.

1 Press OPEN/CLOSE on the unit to open the tray and insert a disc. (p. 40)

- Press the button again to close the tray.

2 Press PLAY/×1.3.

- The unit takes some time to read the disc before play starts.



- RAM DVD-R
Play starts from the most recently recorded title.
- DVD-V DVD-A CD
Play starts from the beginning of the disc.

Notes:

- Depending on the disc, playback may start automatically. DVD-V
- If cartridge protection is activated (p. 7), play begins automatically when you close the tray. RAM
- If an interactive DVD is used, the DVD Main Menu appears. DVD-V
- If a menu screen is used, it is possible to playback looking at disc tree view. (p. 53) MP3

To stop

Press STOP.

- Press STOP again to return to the television screen.
- DVD-V CD MP3
- When "PB" flashes on the Front Display, resume function is active. (See below.)
- The screen saver may appear when you stop play. Press STOP again and you can use this unit's tuner to watch television.
- The unit will shut off automatically 5 minutes after you pressed STOP during DVD playback in order to save energy.

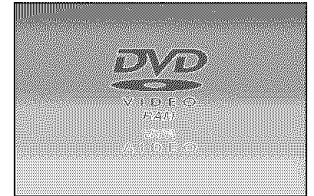

To pause

Press PAUSE.

- Press again to restart play.

When a menu screen appears on the television

DVD-V

1 Press ▲▼◀▶ to select the item and press ENTER.

- Some items can also be selected using the NUMBER keys.

e.g., 5: [0] → [5] 15: [1] → [5]

To return to the menu screen

Press TOP MENU or SUB MENU.

Starting play from where you stopped it (Resume Function)

RAM DVD-R DVD-V CD MP3

1 Press STOP during play.

- "PB" flashes on the unit's display (Normal play only). The unit memorizes the position.

2 Press PLAY/×1.3.

- Play starts from where you stopped it.

To cancel the resume function (Normal play only)

Press STOP while the unit remembers the position. (The position is also cleared when you turn the unit off or open the disc tray.)

Various PlayBack

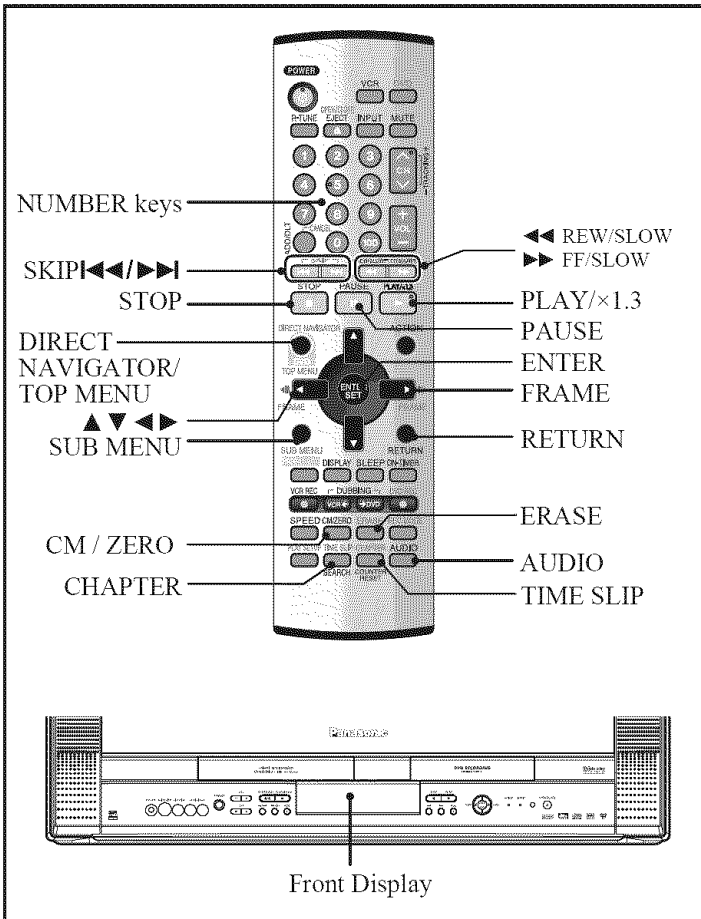

Preparation

- Insert a disc that has been recorded on.

Selecting recorded programs (titles) to play

RAM DVD-R

1 Press DIRECT NAVIGATOR.

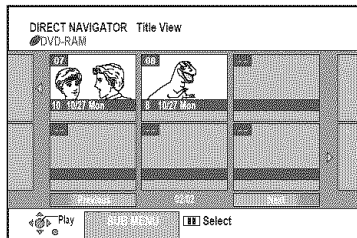

2 Press ▲▼◀▶ to select the title and press ENTER.

- You can also select titles with the NUMBER keys.

e.g., 5: [0] → [5] 15: [1] → [5]

- If you enter a number larger than the total number of titles, the last title is selected.

■ To stop play

- Press STOP.

■ To erase a title during play (p. 58)

- Press ERASE.
- Press ◀▶ to select "Erase" and press ENTER.

■ To edit

- See pages 57-59.

■ To exit the screen

- Press RETURN or DIRECT NAVIGATOR.

DIRECT NAVIGATOR screen icons

- 🔒 : Title protected.
- 🔒 : Title that was not recorded due to recording protection (Digital broadcasts etc.)
- X : Title cannot be played because data is damaged.
- : Currently recording.

Fast forward and rewind (Search)

RAM DVD-R DVD-V CD MP3

1 Press ▶▶ FF/SLOW or ◀◀ REW/SLOW during play.

- On the unit, hold down ▶▶ or ◀◀.
- The speed increases up to 5 steps.
- You can turn off the sound during search. (Refer to "Search Audio & PLAY ×1.3" on page 68.)
- Press PLAY/×1.3 to return to normal speed.

Skipping

RAM DVD-R DVD-V CD MP3

1 Press SKIP ▶▶ or SKIP ◀◀ during play or while paused.

- On the unit, press ▶▶ or ◀◀.
- Each press increases the number of skips.

Skipping a minute forward (CM Skip)

RAM DVD-R

1 Press CM / ZERO during play.

- Play restarts from approximately a minute later.

Note:

- If the start of the next program is within one minute of the point you skipped from, play restarts from the beginning of that program.

Starting from a selected item

RAM DVD-R DVD-V CD MP3

Starting play from a selected title, chapter or track.

1 Press NUMBER keys to select the item during play or while stopped.

e.g., 5: [0] → [5]

15: [1] → [5]

MP3

e.g., 5: [0] → [0] → [5]

15: [0] → [1] → [5]

115: [1] → [1] → [5]

Notes:

- This may not work with some discs.
- This works only when stopped (screen saver is displayed on the television) with some discs.

Slow-motion playback

RAM DVD-R DVD-V

1 Press ►► FF/SLOW or ◀◀ REW/SLOW while paused.

- On the unit, hold down ►► or ◀◀.

- When slow motion play is continued for about 5 minutes it pauses automatically.

■ To return to normal speed

Press PLAY/×1.3.

Notes:

- The speed increases up to 5 steps.
- Press PLAY/×1.3 to restart play.

Quick View

RAM (Only with Dolby Digital)

The play speed can be increased without distorting the audio.

1 Hold down PLAY/×1.3 during play.

■ To return to normal speed

Press PLAY/×1.3.

Notes:

- Output is in PCM when using a digital connection. (p. 14)
- This is cancelled when you perform skip, pause, or when play reaches a point where a program recorded in sound other than Dolby Digital starts.
- This does not work if the setting is "Off" in "Search Audio & PLAY×1.3". (p. 68)
- This does not work when recording is in XP or FR mode during simultaneous recording and play. (p. 48).

Frame-by-frame viewing

RAM DVD-R DVD-V

1 Press FRAME II► or FRAME ◀II while paused.

■ To return to normal speed

Press PLAY/×1.3.

Notes:

- Each press shows the next frame.
- Press PLAY/×1.3 to restart play.
- Whether pictures are advanced by "Field" or "Frame" is selected automatically (see page 68.)

Displaying the television image as a picture-in-picture

RAM

1 Press TIME SLIP during play.

The unit displays the television image as a picture-in-picture.

- You will hear the playback audio.
- Press TIME SLIP again to cancel.

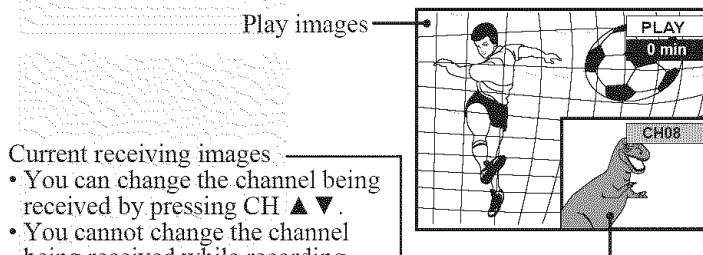

■ To show the play images in full

Press TIME SLIP.

Skipping the specified time (Time Slip)

RAM

1 Press TIME SLIP during play.

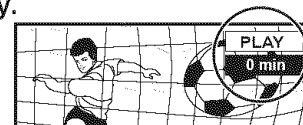

2 Press ▲▼ to select the time while the indication is displayed.

- The time indicator will go off after about 5 seconds, but will turn on again when you set the indicator.
- Press ▲▼ to alter in one-minute units. Press and hold ▲▼ to alter in 10-minute units.

3 Press ENTER.

- Play skips the specified time.

• When  appears on the screen while a button is being pressed, it means that the corresponding operation is prohibited by the unit or the disc.

Using menus to play MP3

MP3

This unit can play MP3 files recorded on CD-R/RW with a computer. Files are treated as tracks and folders are treated as groups.

1 Press TOP MENU during stop or play.

- G:** Group no.
T: Track no. in the group
TOTAL: Track no./Total track no. in all groups
- Selected group

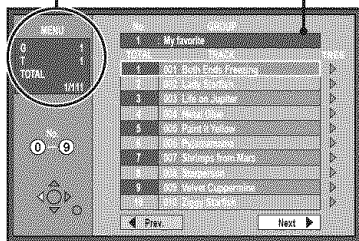



Using the tree screen to find a group

2 Press to display the tree screen while the file list is displayed. Press to select a group and press ENTER.

- The file list for the group appears.

Note:

- Press   to jump layers in the tree screen.

Selected group no. /Total group no.
 If the group has no track, “- -” is displayed as group number.

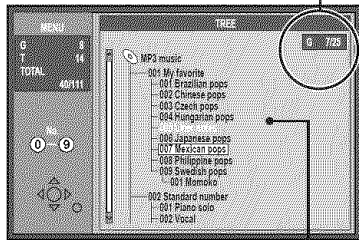

You cannot select groups that contain no compatible files.





Using the tree screen to find a track

2 Press to select the track and press ENTER.

- Play continues to the last track in the last group.
- “” indicates the track currently playing.
- You can also select the track with the NUMBER keys.

e.g., 5: [0] → [0] → [5]
 15: [0] → [1] → [5]
 115: [1] → [1] → [5]

■ To show other pages

- Press     to select “Prev.” or “Next” and press ENTER.
- After listing all the tracks in one group, the list for the next group appears.

■ To exit the screen

- Press RETURN or TOP MENU.

Notes:

- Reading or play of the disc may take time if there are a lot of sessions.
- The display order may differ from how the order is displayed on a computer.
- A folder which has no MP3 files is indicated in black. You cannot select groups with no MP3 files.

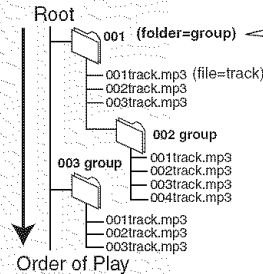

Naming folders and files

At the time of recording, give folder and file names a 3-digit numeric prefix in the order you want them to play (this may not work at times).

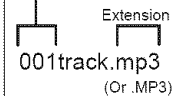

- For other notes concerning the MP3, see page 8.

To erase a program that is being played back

RAM DVD-R

You can erase titles while playing.

Since the program, and play lists (see page 60) created from it are erased irretrievably by this procedure, you should be certain you wish to erase before carrying it out.

1 Press ERASE during play.

- A confirmation screen will be displayed.

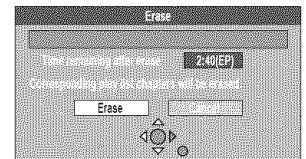

2 Press to select “Erase” and press ENTER.

Notes:



- **RAM** It is not possible to erase the program when you are carrying out simultaneous recording and play. (p. 48)
- **DVD-R** The amount of space remaining on the disc does not increase even if you erase programs.
- If the confirmation screen disappears before you complete the operation, start from the beginning again.
- It is not possible to erase a title that is in the process of being recorded.

• When  appears on the screen while a button is being pressed, it means that the corresponding operation is prohibited by the unit or the disc.

Create chapters

RAM

1 Press CHAPTER during play.

- "CHAPTER" lights on the Front Display for a few seconds.
- Press SKIP  or SKIP  to skip to the start of a chapter.
- You cannot activate this function when recording and playing at the same time.

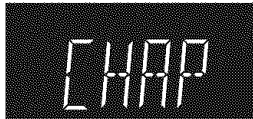

Notes:

- You can play and edit the created chapters. (pp. 57-62)
- For other notes concerning the chapter, see page 57.

Changing audio during play

RAM DVD-V

You can change the audio being received or played.

1 Press AUDIO.

How the type changes depends on when you press the button.

While playing DVD-RAM

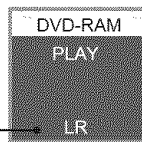

e.g., DVD-RAM "L R" is selected

Notes:

- The audio cannot be changed while Time Slip is used.
- You may be unable to change the audio when you have connected the unit to an AV receiver through the DIGITAL AUDIO OUT terminal and "Dolby Digital" is set to "Bitstream". If this occurs:
 - Change "Dolby Digital" to "PCM" (p. 69), or "Bitstream."
 - Connect also with an audio cable (pp. 14-15) and change the input on the receiver.

While playing DVD-Video

You can change the audio channel number each time you press the button. This allows you to change things like the soundtrack language.



e.g., **DVD-V** English is selected language.

Using On-Screen Menus

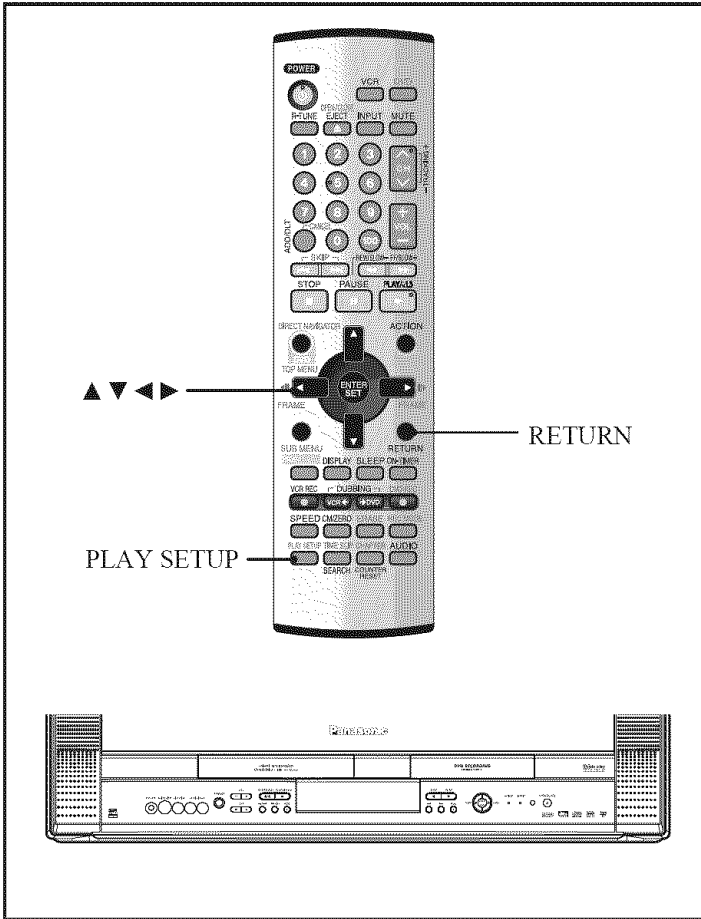

Common procedures

1 Press **PLAY SETUP** in play mode.

e.g., DVD-RAM

Disc	Sound track	1	Digital 2/0 ch
Play	Subtitle	OFF	
	Audio channel	L R	

Menu Item Setting

2 Press **▲▼** to select the menu and press **▶**.

3 Press **▲▼** to select the item and press **▶**.

4 Press **▲▼** to select the setting.

■ To clear the on-screen menus

Press **RETURN**.

Notes:

- Some items can be changed by pressing **ENTER**.
- Some items can also be changed with the **NUMBER** keys.
- The screens depend on the disc contents.
- Depending on the disc contents, there are some items that you cannot select or change.

Disc menu

Not available when playing CDs and MP3 discs.

e.g., DVD-RAM

Disc	Sound track	1	Digital 2/0 ch
Play	Subtitle	OFF	
	Audio channel	L R	

Sound track	Sound track language DVD-V See A below.
	Audio attribute RAM DVD-R DVD-V See B on page 56.
	Karaoke vocal, on and off DVD-V Solo: Duet:
Subtitle	Subtitle language DVD-V See A below. • Changing the subtitle language is only possible with discs on which two or more subtitle languages are recorded. • Any change must be made from the menu recorded on the disc. (Not available on all discs.)
	Subtitle on/off RAM DVD-R DVD-V Turn the Subtitle ON or OFF.
Audio Channel	Audio channel RAM Select the audio channel. (p. 54)
Angle	Angle number DVD-V • Changing the angle is only possible with discs on which two or more angles are recorded. • Any change must be made from the menu recorded on the disc. (Not available on all discs.)

A Sound track/subtitle language

ENG: English	SVE: Swedish	CHI: Chinese
FRA: French	NOR: Norwegian	KOR: Korean
DEU: German	DAN: Danish	MAL: Malay
ITA: Italian	POR: Portuguese	VIE: Vietnamese
ESP: Spanish	RUS: Russian	THA: Thai
NLD: Dutch	JPN: Japanese	*: Others (see pages 67-69)

(Continued on next page.)

• When  appears on the screen while a button is being pressed, it means that the corresponding operation is prohibited by the unit or the disc.

B Sound track/subtitle language

LPCM/ Digital/DTS/MPEG: Signal type

k (kHz): Sampling frequency

b (bit): Number of bits

ch (channel): Number of channels

e.g., 3/2 .1ch

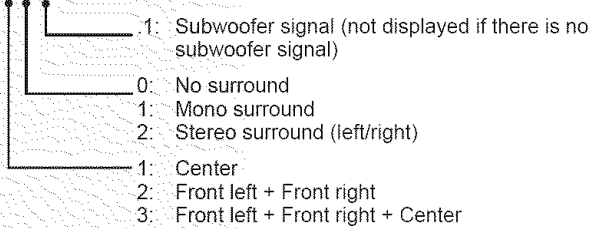

Notes:

- When playing back recordings of SAP broadcasts, "1+1 ch" will be displayed.
- You can only select subtitles, soundtracks, and angles if they are recorded on the disc.
- Some discs allow changes to soundtracks, subtitles, and angles only by using the disc's menus.
- If the subtitles overlap closed captions recorded on discs, turn the subtitles off.

Play menu

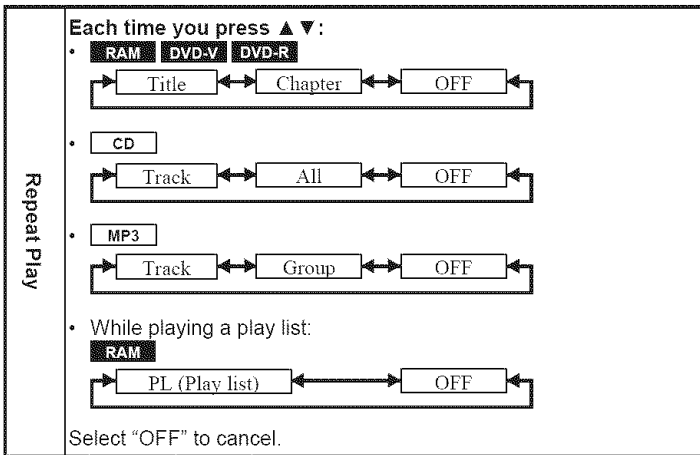
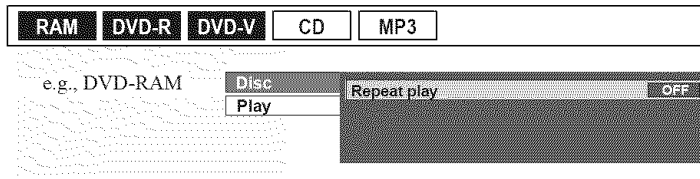

Notes:

- You cannot use repeat play to repeat an entire DVD-Video, MP3 discs or all the play lists on a DVD-RAM.
- Repeat play does not work if the disc's elapsed play time is not shown on the unit's display.
- ERASE does not work while in repeat play mode.

Editing the Recorded Programs (Using the Direct Navigator)

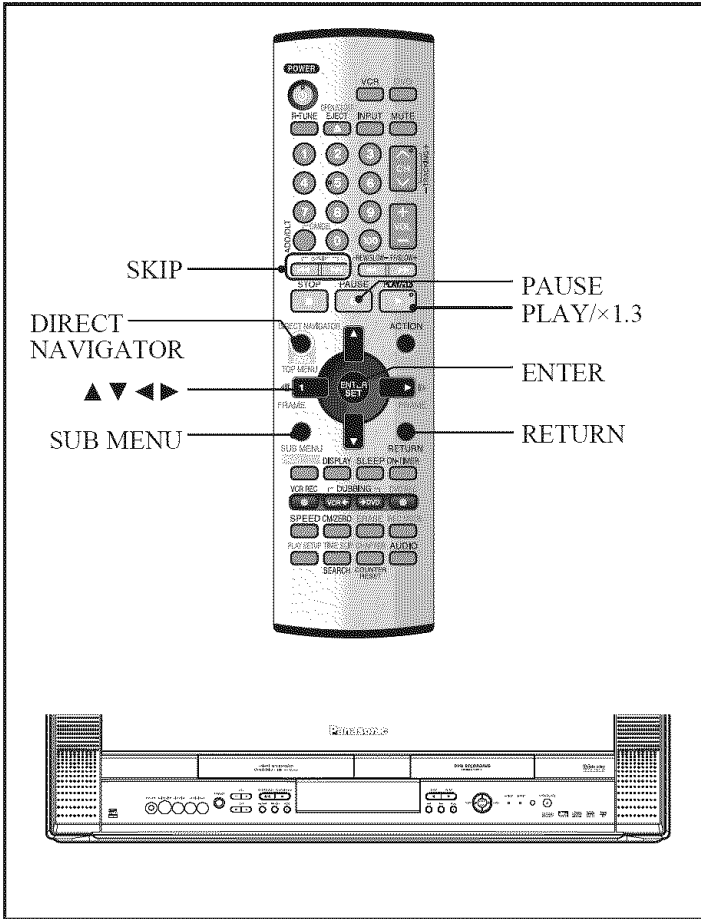

Preparation

- Release protection before proceeding:
 - Cartridge (p. 7) **RAM**
 - Disc (p. 63) **RAM**
- When the title is protected (p. 58), you can only access "Properties" and "Cancel Protection". Release the protection to access other items. **RAM**

1 Press DIRECT NAVIGATOR.

2 Press ▲▼◀▶ to select the title.

- You can also select a title by entering a 2-digit number with the numeric buttons.

e.g., 5: [0] → [5]
15: [1] → [5]

- If you enter a number larger than the total number of titles, the last title is selected.

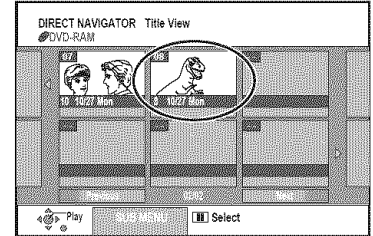

■ To show other pages

Press ▲▼◀▶ to select "Previous" or "Next" and press ENTER.

- You can also press SKIP ▶▶ or SKIP ◀◀ to show other pages.

■ Multiple editing

Select with ▲▼◀▶ and press II (PAUSE). (Repeat.)

A check mark appears. Press II (PAUSE) again to cancel.

3 Press SUB MENU, then ▲▼ to select the operation and press ENTER.

- If you select "Edit", press ▲▼ to select the operation and press ENTER.

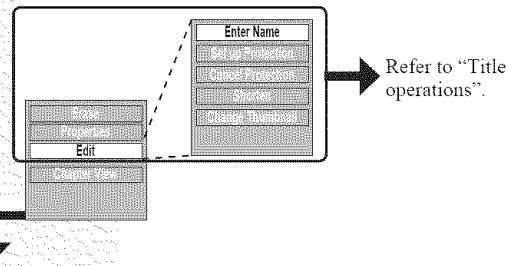

■ If you select "Chapter View".

4 Press ▲▼◀▶ to select the chapter.

- You can also select a chapter by entering a 3-digit number with the numeric buttons.

e.g., 5: [0] → [0] → [5]
15: [0] → [1] → [5]
115: [1] → [1] → [5]

- If you enter a number larger than the total number of chapters, the last chapter is selected.

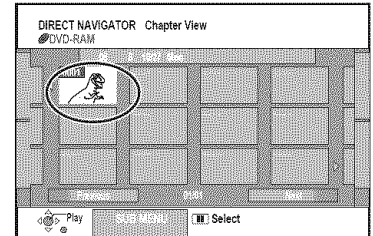

■ To start play

Press ENTER.

■ To edit

Go to Step 5 on next page.

- To show other pages/Multiple editing (see above)

(Continued on next page.)

Editing titles/chapters and playing chapters

RAM DVD-R

■ Title/Chapter

Programs are recorded as a single title consisting of one chapter.

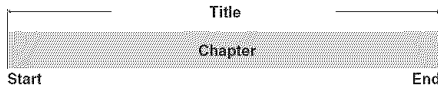

You can divide a title into multiple chapters. (see "Create Chapter" on page 54, "Divide Chapter" on page 59) **RAM**

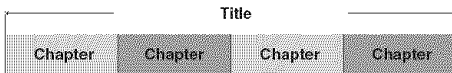

You can change the order of chapters and create a play list. **RAM**

- Titles are divided into about 5-minute chapters after finalizing. (p. 65) **DVD-R**

The maximum number of items on a disc:

- Titles: 99
- Chapters: Approximately 1 000 (Depends on disc contents.)

Notes:

- Once erased or partially erased, it cannot be restored to its original state. Make certain before proceeding.
- You cannot edit during recording.

5 Press SUB MENU, then ▲ ▼ to select the operation and press ENTER.

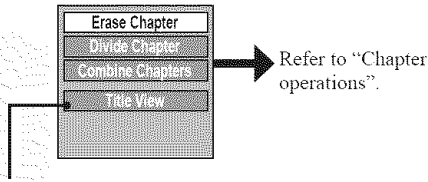

You can go back to the Title View.

■ **To exit the screen**

Press DIRECT NAVIGATOR.

■ **To return to the previous screen**

Press RETURN.

Title operations

1 Do Steps 1~3 on page 57.

Erase

RAM DVD-R (Multiple editing is possible. (p. 57))

The title is irretrievably erased when you use this procedure and cannot be retrieved. Check the title carefully before erasing to ensure it isn't one you want to keep.

2 Press ◀▶ to select "Erase" and press ENTER.

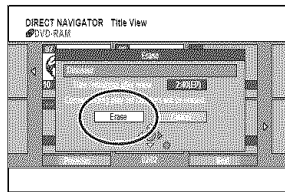

Notes:

- The disc's available recording time may not increase after erasing short titles.
- The available recording time on DVD-R does not increase when you erase titles.

Properties

RAM DVD-R

Information (e.g., time and date) is shown.

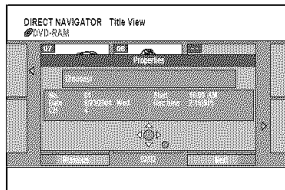

Edit → Enter Name

RAM DVD-R

Refer to "Entering text" on page 66.

Note:

- The full name is shown in the "Properties" screen, but if you enter a long name, only part of it is shown in the title list.

Edit → Set up Protection/Cancel Protection

RAM (Multiple editing is possible. (p. 57))

If set, this will protect the title from accidental erasure.

2 Press ◀▶ to select "Yes" and press ENTER.

- The lock symbol "🔒" appears when the title is protected.

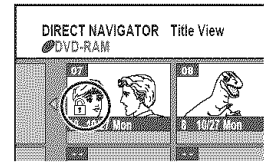
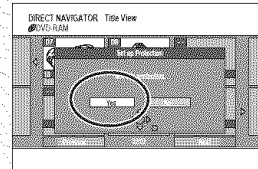

Note:

- Titles will be erased even if they are protected if you format the disc with DISC SETTING. (p.64)

Edit → Shorten

RAM

You can remove unnecessary parts of the recording such as commercials.

- The program segment, and play list scenes created from it, are erased irretrievably when you use this procedure. Check carefully before proceeding.

2 Press ENTER at the start point and end point of the section you want to erase.

- See "For quicker editing" on page 59.

3 Press ▲ ▼ to select "Exit" and press ENTER.

- Select "Next" and press ENTER to erase other sections.

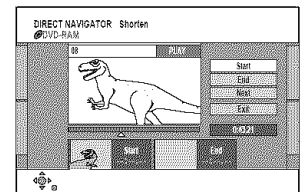

4 Press ▲ ◀ to select "Erase" and press ENTER.

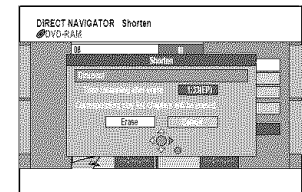

■ **To erase another part of the same title**

After storing the point in "Start" and "End", select "Next" in Step 2 and perform Step 4, then repeat Steps 2~4.

Notes:

- You may not be able to specify start and end points within 3 seconds of each other.
- You cannot specify start and end points if the picture recorded is stilled.
- The unit pauses when the title reaches its end during this procedure.
- The disc's available recording time may not increase after erasing short parts of titles.

• When  appears on the screen while a button is being pressed, it means that the corresponding operation is prohibited by the unit or the disc.

Edit → Change Thumbnail

RAM DVD-R

You can change an image to be shown as a thumbnail picture in the Title View.

- 2 Press **PLAY/×1.3** to start play.
- 3 Press **ENTER** when the image you want to use as a thumbnail is shown.
 - See "For quicker editing" on this page.
 - To change to another point in the same title:
Select "Change" with **▲▼** and press **PLAY/×1.3**, and then repeat Steps 3~4.
- 4 Press **▲▼** to select "Exit" and press **ENTER**.
 - The displayed scene is changed at this point.

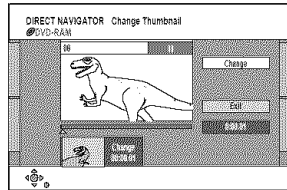

Chapter operations

- 1 Do Steps 1~5 on pages 57-58.

Erase Chapter

RAM (Multiple editing is possible. (p. 57))

- 2 Press **◀▶** to select "Erase" and press **ENTER**.
 - Even if you erase the chapter, the original title is not erased.

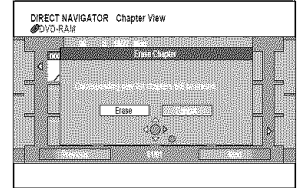

Divide Chapter

RAM

- 2 Press **ENTER** at the point you want to divide.
 - See "For quicker editing" on this page.
 - Repeat this step to divide at other points.

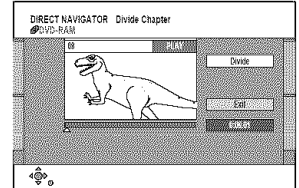

- 3 Press **▲▼** to select "Exit" and press **ENTER**.
 - A little portion of the recording directly preceding the division point may be lost.

Notes:

- The divided chapters retain the name of the original title. They also retain the CPRM property (p. 74) of the original.
- It is not possible to carry out "Divide", when the resulting part(s) are extremely short.

Combine Chapters

RAM

- 2 Press **◀▶** to select "Combine" and press **ENTER**.
 - The selected chapter and next chapter are combined.

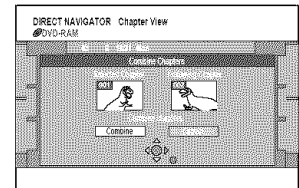

For quicker editing

- Use search (p. 51), Time Slip (p. 52) or slow-motion (p. 52) to find the desired point.
- Press **SKIP ▶▶** or **SKIP ◀◀** to skip to the end of a title.

Using Play List

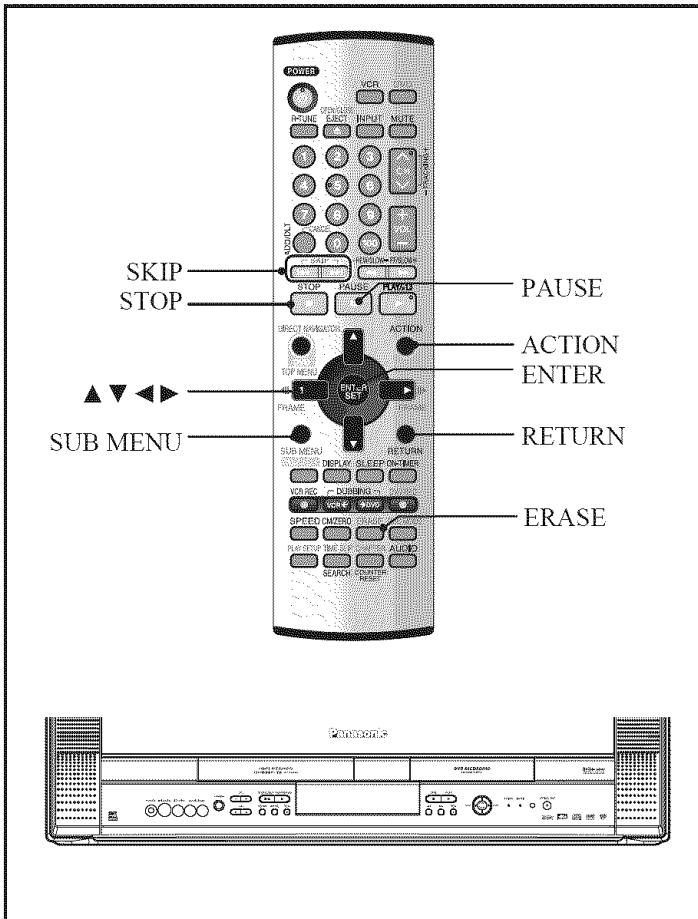

- 1 Press ACTION to display MAIN MENU and select "DVD" then press ENTER. (P.41)
- 2 Press ▲▼◀▶ to select "PLAY LIST" and press ENTER.

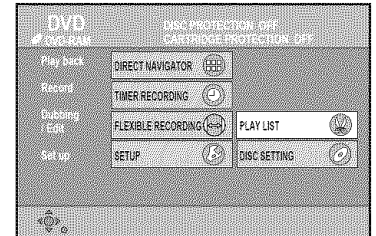

- 3 Press ▲▼◀▶ to select "Create" and press ENTER.

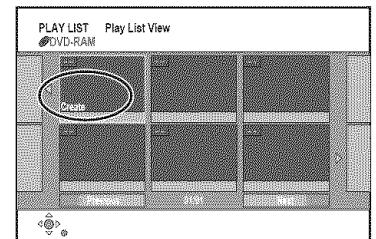

- 4 Press ◀▶ to select the source title and press ▼.

■ When you want to select all chapters in the title:

- Press ◀▶ to select the source title and press ENTER, then skip to Step 6.
- Repeat 4-6 to add other titles or chapters.

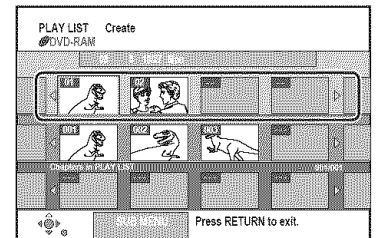

- 5 Press ◀▶ to select the chapter you want to add to a play list and press ENTER.

- Press ▲ to cancel.

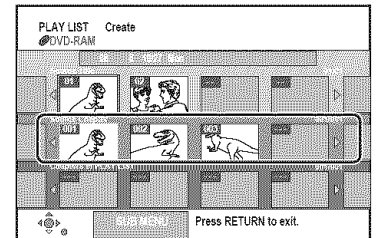

- You can also create a new chapter from the source title. Press SUB MENU to select "Divide Chapter" and press ENTER. (Refer to "Divide Chapter" on page 59.)

Creating play lists

RAM

You can create a play list by gathering your favorite chapters (p. 57) from your recordings. You can also edit the created play list.

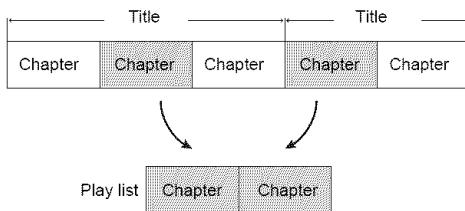

- Editing play lists doesn't modify the recording data.
- Play lists are not recorded separately so this doesn't use much capacity.



The maximum number of items on a disc:

- Play lists: 99
- Chapters in play lists:
Approximately 1 000
(Depends on disc contents.)

Preparation

- Release protection before proceeding:
 - Cartridge (p. 7)
 - Disc (p. 63)

• When  appears on the screen while a button is being pressed, it means that the corresponding operation is prohibited by the unit or the disc.

6 Press   to select the position to insert the chapter and press ENTER.

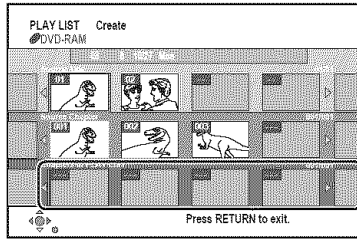

- Repeat steps 5~6 to add other chapters.
- Press  to select other source titles.

7 Press RETURN.

■ **To stop partway through**
Press RETURN.





■ **To clear the play list screen**
Press RETURN.

Playing play lists





Preparation:

- Create play lists first. (p. 60)

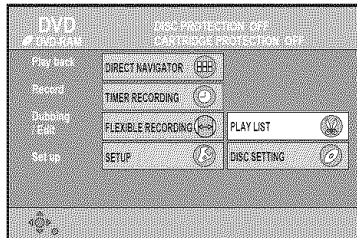
1 Press ACTION to display MAIN MENU and select "DVD" then press ENTER. (P.41)

2 Press     to select "PLAY LIST" and press ENTER.



3 Press     to select the play list and press ENTER.







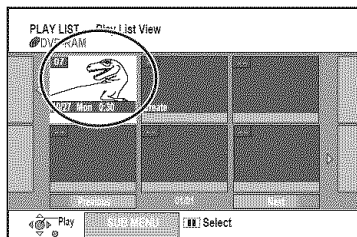

- You can also select a playlist from the chapter view by entering a 2-digit number with the numeric buttons.

e.g. 5: [0] → [5]
15: [1] → [5]

- Whenever a number greater than the total number of play lists is entered, "Create" is selected.





■ **To show other pages**

- Press     to select "Previous" or "Next" and press ENTER.
- You can also press SKIP   or SKIP   to show other pages.

■ **To stop play list play**

- Press STOP. (The play list appears.)





■ **To erase a play list during play (p. 62)**

- Press ERASE.
- Press   to select "Erase" and press ENTER.



Using play list to edit play list/chapters

- You can use fast-forward, rewind, pause, and slow-motion while playing chapters just as you can during normal play.

■ **Multiple editing**

- Select with     and press PAUSE. (Repeat.)
- A check mark appears. Press PAUSE again to cancel.

4 Press SUB MENU, then   to select the operation and press ENTER.

- If you select "Edit", press   to select the operation and press ENTER.

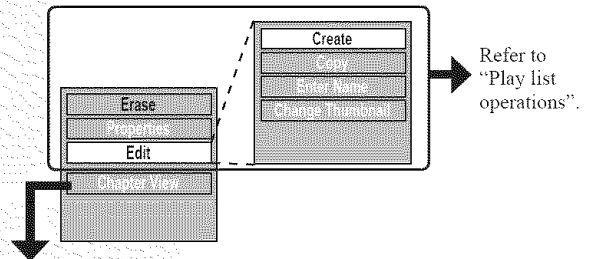

■ **If you select "Chapter View"**

5 Press     to select the chapter.

- You can also select a chapter by entering a 3-digit number with the numeric buttons.

e.g., 5: [0] → [0] → [5]
15: [0] → [1] → [5]
115: [1] → [1] → [5]

- If you enter a number larger than the total number of chapters, the last chapter is selected.

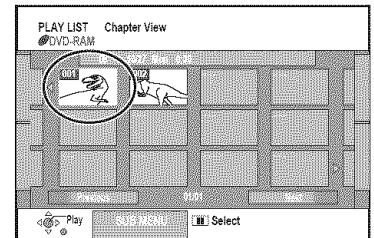



■ **To play a chapter**

- Press ENTER.

■ **To stop chapter play**

- Press STOP. (The chapter view appears.)

■ **To erase a chapter during play**

- Press ERASE.
- Press   to select "Erase" and press ENTER.

- **To show other pages/Multiple editing (see above)**

(Continued on next page.)

• When  appears on the screen while a button is being pressed, it means that the corresponding operation is prohibited by the unit or the disc.

6 Press SUB MENU, then   to select the operation and press ENTER.

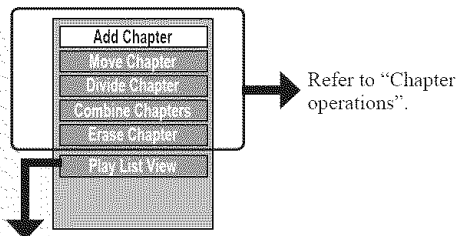

You can go back to PLAY LIST View.

■ To exit the screen

Press RETURN several times.

■ To return to the previous screen



Press RETURN.

Play list operations

1 Do Steps 1~5 on page 61.

Erase

RAM (Multiple editing is possible. (p. 61))

2 Press   to select "Erase" and press ENTER.

- The play list is erased.
- Once a play list has been erased, it is irretrievable. Check carefully before proceeding.

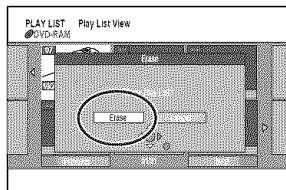

Properties

RAM

Play list information (e.g., time and date) is shown.

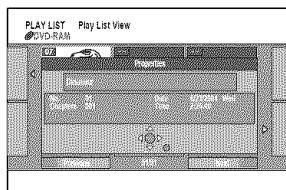



Edit → Create

RAM

Refer to "Creating play lists" on pages 60-61.

Edit → Copy

RAM (Multiple editing is possible. (p. 61))

2 Press   to select "Copy" and press ENTER.

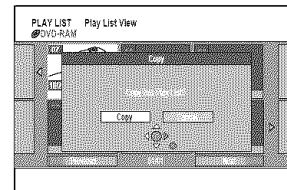

Edit → Enter Name

RAM

Refer to "Entering text" on page 66.

Note:

- The full name is shown in the "Properties" screen, but if you enter a long name, only part of it is shown in the play list screen.

Edit → Change Thumbnail

RAM

Refer to "Change Thumbnail" on page 59.

Chapter operations

1 Do Steps 1-6 on pages 61-62.

Add Chapter

RAM

Refer to "Creating Play lists", Step 4-7 on pages 60-61.

Move Chapter

RAM

2 Press     to select the position to insert the chapter and press ENTER.

- The chapter is moved and inserted before the highlighted chapter.

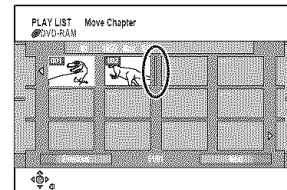

Divide Chapter

RAM

Refer to "Divide Chapter" on page 59.

Combine Chapters

RAM

Refer to "Combine Chapters" on page 59.

Erase Chapter

RAM (Multiple editing is possible. (p. 61))

Refer to "Erase Chapter" on page 59.

Disc Setting

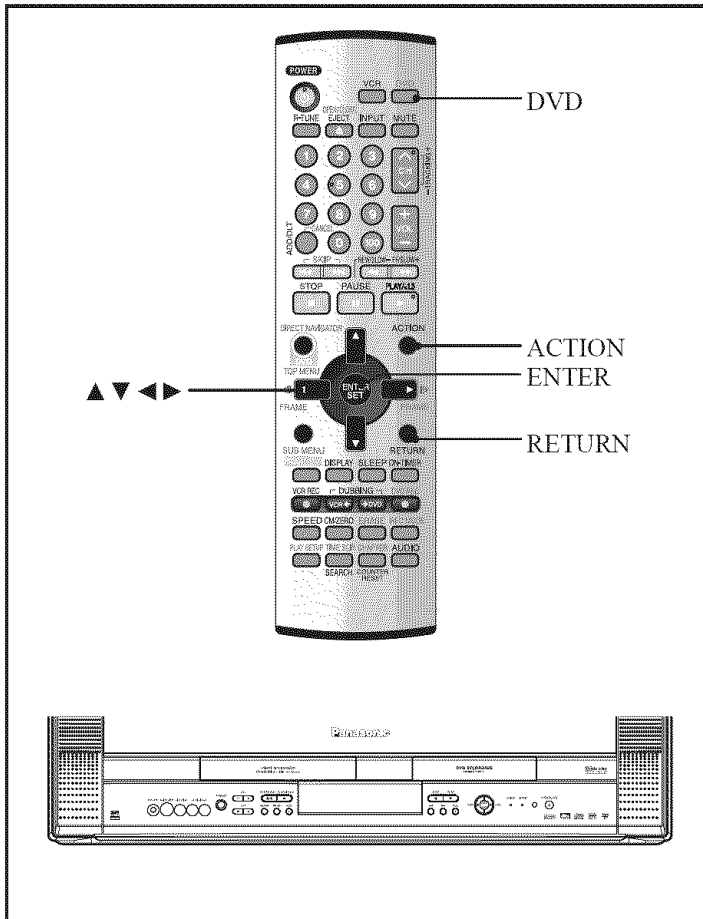

- Press **▲▼** to select the operation and press **ENTER**.
• After this operation, follow the desired operation.

e.g., DVD-RAM

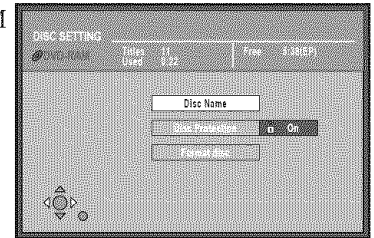

- To stop partway**
Press **RETURN**.

Disc Name

RAM **DVD-R**

- Press **▲▼** to select “Disc Name” and press **ENTER** in Step 3 above.

- Refer to “Entering text” on page 66.
• The disc name is displayed in the DVD Functions window.

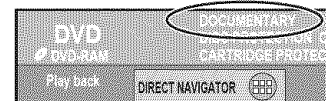

Disc Protection

RAM

This allows you to protect discs from accidental erasure.

- Press **▲▼** to select “Disc Protection” and press **ENTER** in Step 3 above.

- Press **◀▶** to select “Yes” and press **ENTER**.

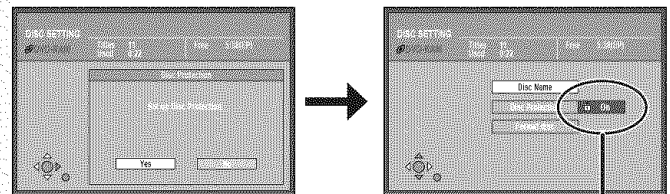

The lock symbol “” appears closed when the disc is write-protected.

Disc Setting Procedure

RAM **DVD-R**

Preparation

- Press **DVD** to select the drive.
- Release protection before proceeding:
 - Cartridge (p. 7) **RAM**
 - Disc (p. 63) **RAM**

- Press **ACTION** to display **MAIN MENU** and select “**DVD**” then press **ENTER**. (P.41)

- Press **▲▼◀▶** to select “**DISC SETTING**” and press **ENTER**.

e.g., DVD-RAM

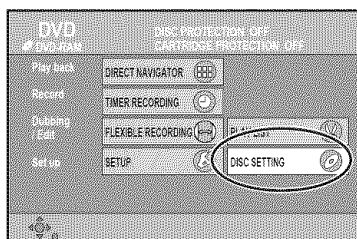

Format Disc

RAM

(Refer to "Formatting" on page 74.).

Notes:

- Formatting erases all contents on the disc, including computer data. Check carefully before proceeding.
- Some DVD-RAM are unformatted. Format them before using them in this unit. Formatting also allows you to erase the entire contents of a disc.

1 Press **▲▼** to select "Disc Format" and press **ENTER**.

2 Press **◀▶** to select "Yes" and press **ENTER**.

e.g., DVD-RAM

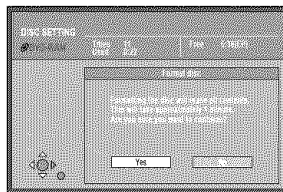

3 Press **◀▶** to select "Start" and press **ENTER**.

e.g., DVD-RAM

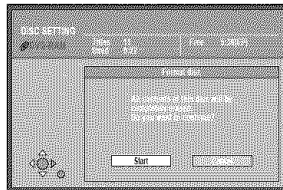

- A message appears when formatting is finished.

4 Press **ENTER**.

■ To stop formatting

Press **RETURN**.

Notes:

- Do not turn the unit off or disconnect the AC power supply cord while the message "Formatting the disc" is on the TV. This can render the disc unusable. (This can take up to max. 70 minutes (DVD-RAM). If it takes more than 2 minutes, you can cancel formatting by pressing **RETURN**. The disc must be reformatted if you do this.)
- All data on the disc is erased when it is formatted, including recordings made with this unit. Data written to the disc by a computer is also erased.
- When a disc has been formatted using this unit, it may not be possible to use it on any other equipment.
- The disc cannot be formatted if the write protect tab (p. 7) is switched to "PROTECT". Release the protection to continue.
- The message "Unable to format" appears when trying to format discs this unit cannot use.
- DVD-R and CD-R/RW cannot be formatted.

Select First play

DVD-R

Select whether to show the top menu after finalizing the disc. Do this before finalizing the disc.

1 Press **▲▼** to select "Select First play" and press **ENTER** in Step 3 on page 63.

2 Press **▲▼** to select "Top Menu" or "Title 1" and press **ENTER**.

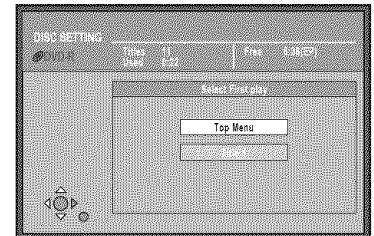

Top Menu: The top menu appears first.

Title 1: The disc content is played without displaying the top menu.





• When  appears on the screen while a button is being pressed, it means that the corresponding operation is prohibited by the unit or the disc.

Finalize



DVD-R (DVD-R recorded on this unit only)

(Refer to “Finalize” on page 74.)

You can play DVD-R on compatible DVD players by finalizing them on this unit, effectively making them into DVD-Video that complies with DVD-Video standards.

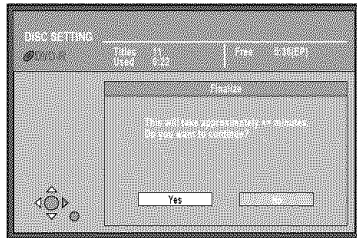
- 1 Press   to select “Finalize” and press ENTER.
- 2 Press   to select “Yes” and press ENTER.



- 3 Press   to select “Start” and press ENTER.
 - Finalizing starts.
 - A message appears when finalizing is finished.

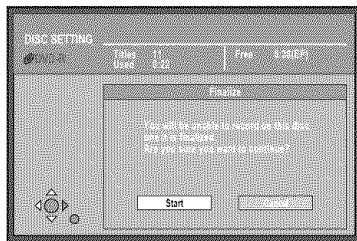

- 4 Press ENTER.

Notes:

- Do not disconnect the AC power supply cord while the message “Finalizing the disc” is on the television. This will render the disc unusable.
- Finalizing takes up to 15 minutes.
- You can only finalize DVD-R that were recorded on this unit.
- You cannot record on DVD-R that have been finalized.
- **After finalizing**
 - The disc becomes play-only and you can no longer record or edit it.
 - DVD-R finalized on this unit may not be playable on other DVD players due to the condition of the recording.
 - There is a pause of several seconds between titles.
 - Titles are divided into about 5-minute* chapters.
- * This time varies greatly depending on the condition and mode of recording.
- Visit Panasonic’s homepage for more information about DVDs.
 - For U.S.A.: <http://www.panasonic.com/playDVD-R>
 - For Canada: <http://www.panasonic.ca>

	Before finalizing	After finalizing
Disc display on this unit	DVD-R	DVD-V
Recording/Editing/ Entering name	○	×
Play on other DVD players	×	○

DVD-R finalized on this unit may not be playable on other DVD players due to the condition of the recording.

Entering Text

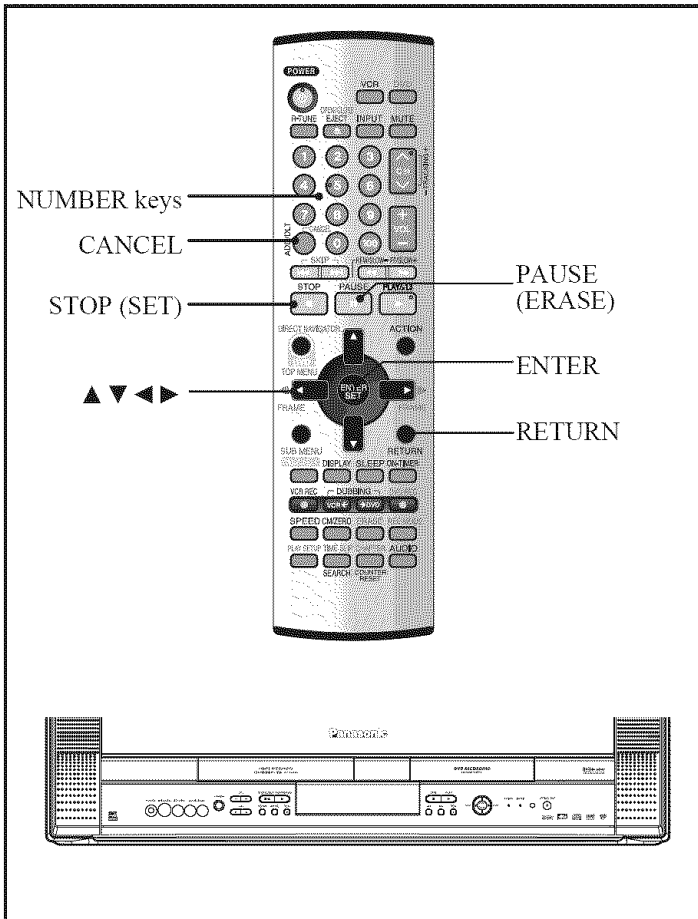

Entering text Procedure

RAM DVD-R

You can give names to recorded titles, etc.

The maximum number of characters:

RAM	Characters
Title	64 (44*)
Play list	64
Disc	64

* Title name for timer recording

DVD-R	Characters
Title	44
Disc	40

- If a name is long, parts of it may not be shown in some screens.

Preparation

- Release protection before proceeding:
 - Cartridge (p. 7) **RAM**
 - Disc (p. 63) **RAM**

1 Show Enter Name screen.

This feature allows you to enter a name/title.	Page
Title	58
Title (timer recording)	46-47
Play list	62
Disc	63

2 Press ▲▼◀▶ to select a character and press ENTER.

Name field:
Shows the text you have entered

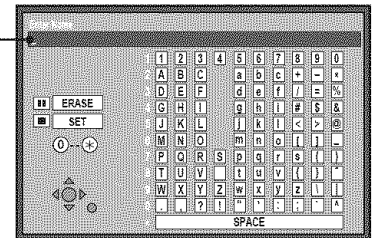

- Repeat this step to enter other characters.

To erase a character

Press ▲▼◀▶ to select the character in the name field and press PAUSE.

- You can also erase characters by selecting "ERASE" and pressing ENTER.

Using the NUMBER keys to enter characters

e.g., entering the letter "R"

- Press 7 to move to the 7th row.
- Press 7 twice to highlight "R".
- Press ENTER.

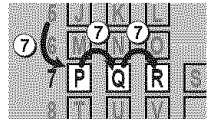

To enter a space

Press CANCEL and press ENTER.

3 Press STOP.

- You can also finish entering the title by selecting "SET" and pressing ENTER.
- Returns to the previously displayed screen.

To end partway

Press RETURN.
• Text is not saved.

Note:

- The full title is shown in the Properties screen (pp. 58, 62), but if you enter a long title, only part of it is shown in the program list or play list screen.
- **DVD-R** If you enter a long title, only part of it is shown in the menu screen after finalization.

Changing the Unit's Settings

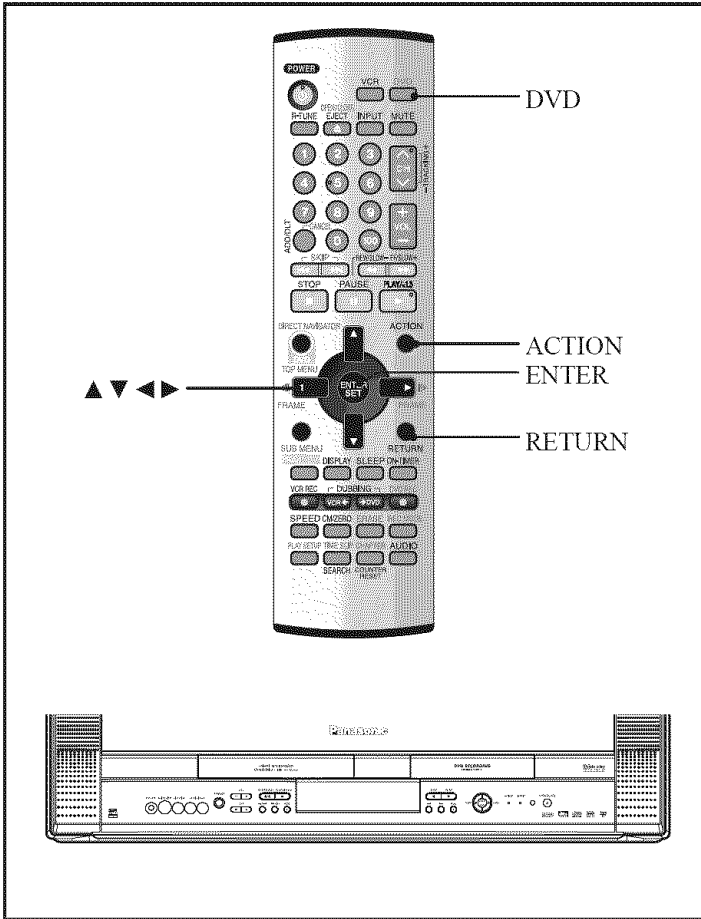

Unit's Settings Procedure

Please see unit's settings list (See next page), and if required, change a setup.
The settings remain intact even if you switch the unit to standby.

- 1 Press ACTION to display MAIN MENU and select "DVD" then press ENTER. (P.41)
- 2 Press ▲▼◀▶ to select "SETUP" and press ENTER.

e.g., DVD-RAM
If you change "Recording Time in EP Mode".

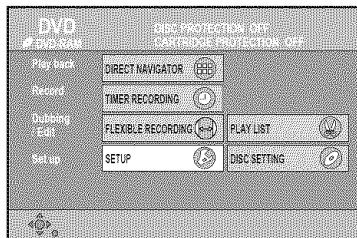

- 3 Press ▲▼ to select the Menus and press ▶.

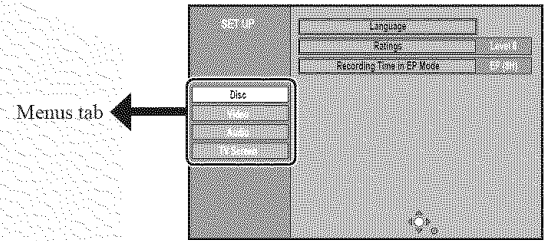

- 4 Press ▲▼ to select the Setting items and press ENTER.

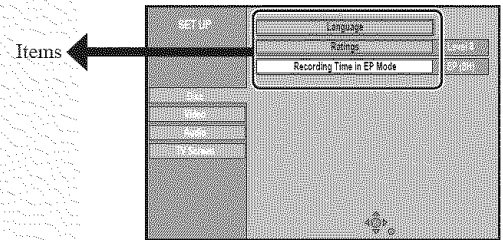

- 5 Press ▲▼ to select the Setting Contents and press ENTER.

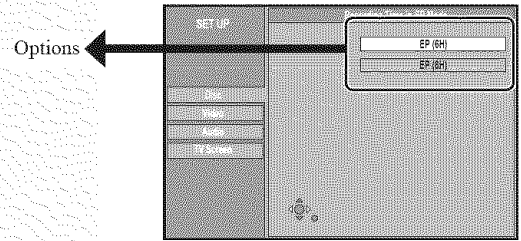

- To return the previous screen
Press RETURN.



Unit's Settings List

See page 67 for details on menu operation.

The settings remain intact even if you switch the unit to standby.

Menus tab	Items	Options (Underlined items are the factory presets.)
Disc	Languages Choose the language for audio, subtitle and disc menus. DVD-V Press ENTER to display the menu.	<ul style="list-style-type: none"> • Enter a code (See next page) when you select "Other ****" • Some discs start in a certain language despite any changes you make here.
	Audio Language	<ul style="list-style-type: none"> • <u>English</u> • French • Spanish • Original: The original language of each disc will be selected. • Other ****
	Subtitle Language	<ul style="list-style-type: none"> • <u>Automatic</u>: If the language selected for "Audio Language" is not available, subtitles of that language will automatically appear if available on that disc. • English • French • Spanish • Other ****
	Menu Language	<ul style="list-style-type: none"> • <u>English</u> • French • Spanish • Other ****
	Ratings Set a ratings level to limit DVD-Video play. Follow the on-screen instructions. Enter a 4-digit password with the NUMBER keys when the password screen is shown. <ul style="list-style-type: none"> • Do not forget your password. 	<ul style="list-style-type: none"> • <u>8 No Limit</u>: All DVD-Video can be played. • 1 to 7: Prohibits play of DVD-Video with corresponding ratings recorded on them. • <u>0 Lock All</u>: Prohibits play of all DVD-Video. • <u>Unlock Recorder</u> • Change Password • <u>Change Level</u> • Temporary Unlock
Recording time in EP mode Select the maximum number of hours for recording in EP mode (refer to "Recording modes and approximate recording times" on page 45).	<ul style="list-style-type: none"> • EP (6 H): You can record for 6 hours on an unused 4.7 GB disc. • <u>EP (8 H)</u>: You can record for 8 hours on an unused 4.7 GB disc. 	
Video	3-D Y/C Separation Allows high quality recording of the received picture.	<ul style="list-style-type: none"> • <u>On</u>: High quality recording is achieved by precise separation of the Y (luminance) and C (color) of the received picture signal. • Off: Set to Off to reduce ghost images when recording pictures with fast motion. Does not work with S-Video input pictures.
	Hybrid VBR Resolution The picture recorded to a DVD-RAM can be smoothed out.	<ul style="list-style-type: none"> • <u>Automatic</u>: The resolution is automated to provide efficient recording with less block noise. RAM • <u>Fixed</u>: The resolution is fixed to ensure that there is no loss of source picture resolution while recording.
	Still Mode Select the type of picture shown when you pause play (Refer to "Frames and fields" on page 74).	<ul style="list-style-type: none"> • <u>Automatic</u>: • <u>Field</u>: Select if jittering occurs when "Automatic" is selected. • <u>Frame</u>: Select small text or fine patterns cannot be seen clearly when "Automatic" is selected.
	Line-in NR Reduces video type noise while dubbing. <ul style="list-style-type: none"> • When noise reduction is on, "3-D Y/C Separation" (see above) does not work regardless of the setting. 	<ul style="list-style-type: none"> • <u>Automatic</u>: Noise reduction only works on input picture from a video tape. • On: Noise reduction works for any input video. • Off: Noise reduction is off. Select when you want to record input as is.
	Black Level Control Select normal, lighter or darker for adjusting the black level control to the desired setting for picture enhancement.	<ul style="list-style-type: none"> • <u>Lighter</u>: • Darker:
	Record level Adjusts the black level of the signal recorded to a DVD.	
Playback level Adjusts the black level of the DVD playback signal.	<ul style="list-style-type: none"> • Lighter: • <u>Darker</u>: 	
Audio	Search Audio & PLAY x1.3 You may hear sound regardless of this setting with some discs.	<ul style="list-style-type: none"> • <u>On</u>: Audio is heard during first level search forward. • Off: Audio is not heard during search. Quick View (see page 52) does not work.
	D.Range Compression DVD-V (Dolby Digital only) Change the dynamic range for late night viewing.	<ul style="list-style-type: none"> • On: • <u>Off</u>:

• When  appears on the screen while a button is being pressed, it means that the corresponding operation is prohibited by the unit or the disc.

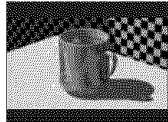
Menus tab	Items	Options (Underlined items are the factory presets.)
Audio	Digital Audio Output Change the settings when you have connected equipment through this unit's DIGITAL AUDIO OUT terminal (see page 14). • Press ENTER to show the menu.	
	PCM Down Conversion Select how to output audio with a sampling frequency of 96 kHz or 88.2 kHz. • Signals are converted to 48 kHz or 44.1 kHz despite the above settings if the signals have a sampling frequency of over 96 kHz or 88.2 kHz, or the disc has copy protection.	• <u>On</u> : Signals are converted to 48 kHz or 44.1 kHz. (Choose when the connected equipment cannot process signals with a sampling frequency of 96 kHz or 88.2 kHz.) • <u>Off</u> : Signals are output as 96 kHz or 88.2 kHz. (Choose when the connected equipment can process signals with a sampling frequency of 96 kHz or 88.2 kHz.)
	Dolby Digital  Select how to output the signal, to output "Bitstream" so the connected equipment decodes the signal, or to decode on this unit and output the signal as "PCM" (2 channel). DTS  Note: • Not making the proper settings may result in noise, possibly damage your hearing and speakers, and digital recording may not work properly.	• <u>Bitstream</u> : When connecting to equipment displaying the Dolby Digital logo. • <u>PCM</u> : When connecting to equipment not displaying the Dolby Digital logo. • <u>Bitstream</u> : When connecting to equipment displaying the DTS logo. • <u>PCM</u> : When connecting to equipment not displaying the DTS logo.
TV Screen	4:3 TV Settings for DVD-Video You can select how to display the image on the TV when you watch 16:9 images (DVD-Video) on a 4:3 standard aspect TV.	• <u>Pan & Scan</u> : Video recorded for a widescreen is played with the sides cut off if Pan & Scan was specified by the producer of the disc. If 16:9 software prohibits Pan & Scan, the image will appear in the letterbox style (with black bands above and below the picture) despite the setting here.  • <u>Letterbox</u> : Video recorded for a widescreen is played in the letterbox style. 
	4:3 TV Settings for DVD-RAM You can select how to display the image on the TV when you watch 16:9 images (DVD-RAM) on a 4:3 standard aspect TV.	• 4:3: Titles played as recorded. • <u>Pan & Scan</u> : Video recorded for a widescreen is played with the sides cut off if the Pan & Scan format is specified at the time of recording. • <u>Letterbox</u> : Video recorded for a widescreen is played in the letterbox style.

Language Code List

Language	Code
Abkhazian	6566
Afar	6565
Afrikaans	6570
Albanian	8381
Ameharic	6577
Arabic	6582
Armenian	7289
Assamese	6583
Aymara	6588
Azerbaijani	6590
Bashkir	6665
Basque	6985
Bengali: Bangla	6678
Bhutani	6890
Bihari	6672
Breton	6682
Bulgarian	6671
Burmese	7789
Byelorussian	6669
Cambodian	7577
Catalan	6765
Chinese	9072
Corsican	6779
Croatian	7282
Czech	6783

Language	Code
Danish	6865
Dutch	7876
English	6978
Esperanto	6979
Estonian	6984
Faroese	7079
Fiji	7074
Finnish	7073
French	7082
Frisian	7089
Galician	7176
Georgian	7565
German	6869
Greek	6976
Greenlandic	7576
Guarani	7178
Gujarati	7185
Hausa	7265
Hebrew	7387
Hindi	7273
Hungarian	7285
Icelandic	7383
Indonesian	7378
Interlingua	7365
Irish	7165

Language	Code
Italian	7384
Japanese	7465
Javanese	7487
Kannada	7578
Kashmiri	7583
Kazakh	7575
Kirghiz	7589
Korean	7579
Kurdish	7585
Laothian	7679
Latin	7665
Latvian, Lettish	7686
Lingala	7678
Lithuanian	7684
Macedonian	7775
Malagasy	7771
Malay	7783
Malayalam	7776
Maltese	7784
Maori	7773
Marathi	7782
Moldavian	7779
Mongolian	7778
Nauru	7865
Nepali	7869

Language	Code
Norwegian	7879
Oriya	7982
Panjabi	8065
Pashto, Pushto	8083
Persian	7065
Polish	8076
Portuguese	8084
Quechua	8185
Rhaeto-Romance	8277
Romanian	8279
Russian	8285
Samoa	8377
Sanskrit	8365
Scots Gaelic	7168
Serbian	8382
Serbo-Croatian	8372
Shona	8378
Sindhi	8368
Singhalese	8373
Slovak	8375
Slovenian	8376
Somali	8379
Spanish	6983
Sundanese	8385
Swahili	8387

Language	Code
Swedish	8386
Tagalog	8476
Tajik	8471
Tamil	8465
Tatar	8484
Telugu	8469
Thai	8472
Tibetan	6679
Tigrinya	8473
Tonga	8479
Turkish	8482
Turkmen	8475
Twi	8487
Ukrainian	8575
Urdu	8582
Uzbek	8590
Vietnamese	8673
Volapük	8679
Welsh	6789
Wolof	8779
Xhosa	8872
Yiddish	7473
Yoruba	8979
Zulu	9085

Transfer (Dubbing) from DVD

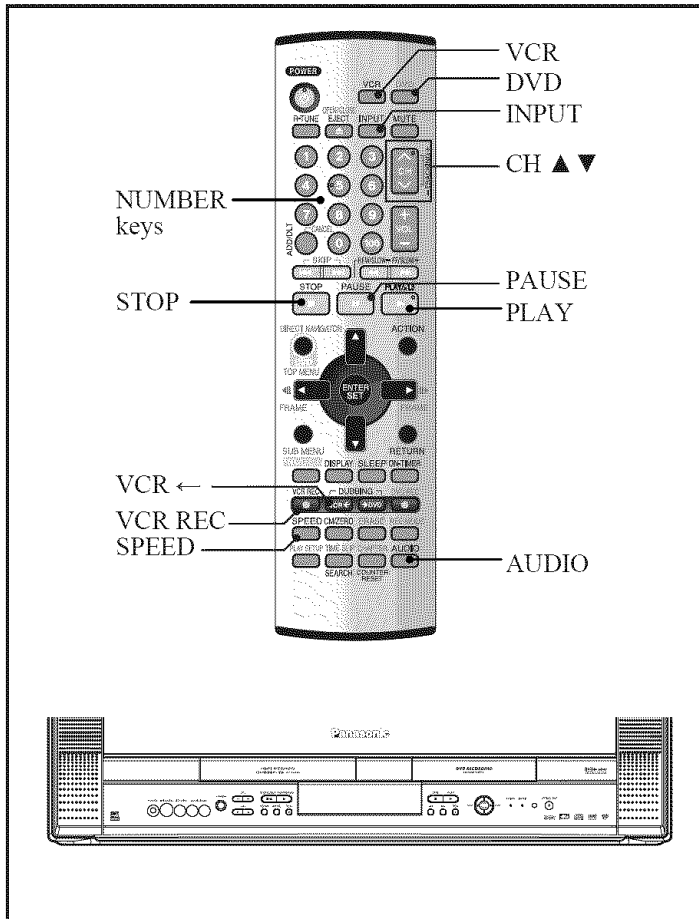

1 With both VCR and DVD in Stop mode, hold down **VCR←** for about 3 seconds after OSD below is displayed.

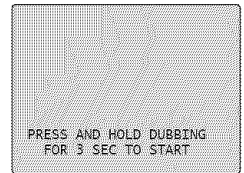

2 Dubbing begins. Information is displayed on the screen and sub display.

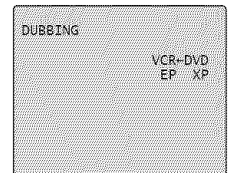

Sub Display

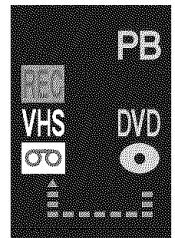

Dubbing stops automatically when disc playback is finished or at tape end.

One Touch Dubbing (DVD → Tape)

You can transfer (dubbing) programs recorded on a disc*1 onto a tape with one stroke of the button.

In One-Touch Dubbing, all contents on the disc are automatically dubbed onto the tapes. If you want to transfer (dubbing) from the desired point, see "Manual Dubbing" on next page.

*1 Available discs for transfer (dubbing) onto tape are DVD-RAM and DVD-R. Most DVD videos cannot be dubbed because they are copy-guarded.

Preparation

DVD side:

- Insert a disc containing programs to be dubbed.

VHS side:

- Insert a cassette with record tab intact.
- Recording will be done from tape beginning. Check tape contents carefully as all existing recordings will be completely dubbed over.
- Select the recording mode. (SP or EP).

■ To end dubbing

Press STOP.

- When playback (source) side ends and unit enters Stop mode, or, if dubbing is stopped due to an error, a message will briefly appear.

■ Only the following operations are allowed while transferring (dubbing):

- Stopping transfer (dubbing) by pressing STOP.
- Changing channels.
 - During dubbing, you can select and watch TV stations using NUMBER keys and Channel ▲▼ keys. To switch back to the dubbing picture, press DVD or VCR. If it is the dubbing picture, CH is not displayed.
- Selecting input mode by pressing INPUT.
- Turning unit ON/OFF by pressing POWER. (Dubbing will continue even if power is turned off.)
- Changing audio mode by pressing AUDIO.

Notes:

- While One Touch Transfer (Dubbing) is activated, timer recording cannot be started.
- When the transfer (dubbing) is not started or not executed, the "DUBBING" indicator blinks for about 7 seconds. Check if the unit is properly prepared.

- When  appears on the screen while a button is being pressed, it means that the corresponding operation is prohibited by the unit or the disc.

Manual Dubbing (DVD → Tape)

You can specify the position to start transfer (dubbing) of the program recorded on the disc*¹ to the tape. In One-Touch Dubbing, all contents on the disc are automatically dubbed onto the tapes.

*¹ Available discs for transfer (dubbing) onto tape are DVD-RAM and non-finalized DVD-R. Most DVD videos cannot be dubbed because they are copy-guarded.

Preparation

DVD side:

- Insert a disc containing programs to be dubbed.
- Select Audio mode. (See page 54.)

VHS side:

- Insert a cassette with record tab intact.
- Make sure there is enough tape remaining

- 1 Set remote to DVD mode.
- 2 Press **PLAY**. Playback starts. Recording start point is located.
- 3 Press **PAUSE** at desired dubbing start point.
- 4 Press **SPEED** to set recording speed. (Select SP or EP mode.)
- 5 Press **VCR REC**. Disc playback starts automatically and dubbing to VCR starts. Dubbing information is displayed on the screen and sub display.

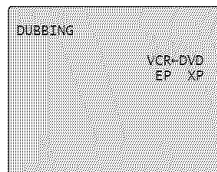

Sub Display



Note:

- VCR REC button is nonfunctional during DVD playback search and during Chase playback.

To end dubbing

Press **STOP**.

- When playback (source) side ends and unit enters Stop mode, or, if dubbing is stopped due to an error, a message will briefly appear.

Only the following operations are allowed while transferring (dubbing)

- Turning unit ON/OFF by pressing **POWER**.
- Stopping transfer (dubbing) by pressing **STOP**.
- Selecting input mode by pressing **INPUT**.
- Changing channels.
 - During dubbing, you can select and watch TV stations using **NUMBER** keys and **Channel ▲▼** keys. To switch back to the dubbing picture, press **DVD** or **VCR**. If it is the dubbing picture, **CH** is not displayed.

Notes:

- While Manual Dubbing (DVD → Tape) is activated, timer recording cannot be started.
- When the transfer (dubbing) is not started or not executed, the "DUBBING" indicator blinks for about 7 seconds. Check if the unit is properly prepared.

Transfer (Dubbing) from Tape

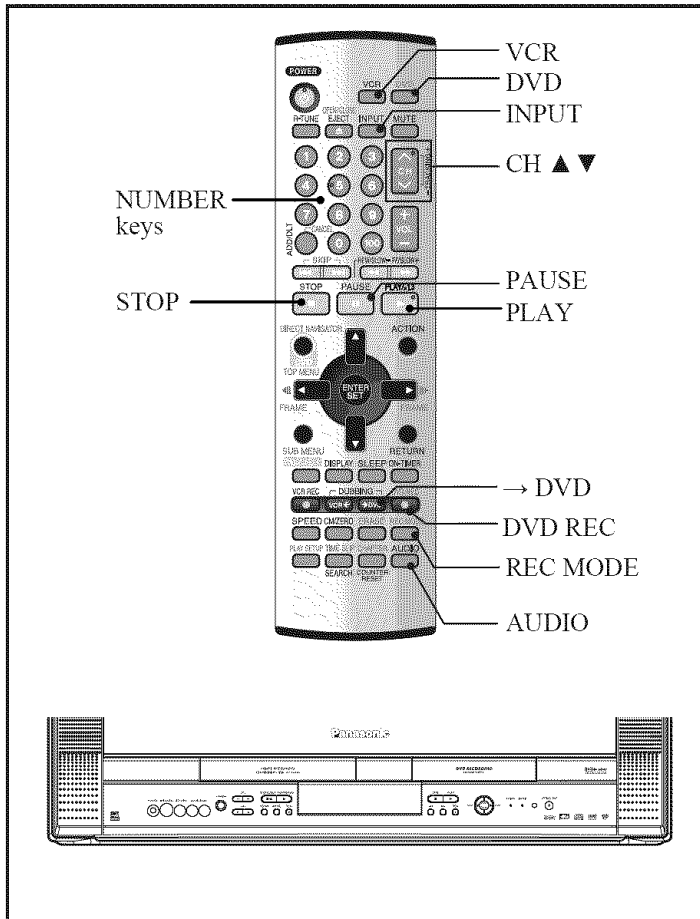

1 With both VCR and DVD in Stop mode, press →DVD and hold down for about 3 seconds after the OSD below appears.

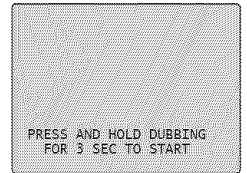

2 Tape rewinds to the beginning automatically.

3 Dubbing begins. Information is displayed on the screen and sub display.

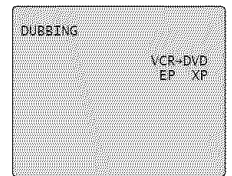

Sub Display

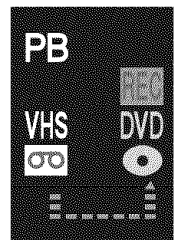

Dubbing stops automatically when tape playback is finished or at disc end.

One Touch Dubbing (Tape → DVD)

RAM DVD-R

You can transfer (dubbing) programs recorded on a tape onto a disc*1 with one stroke of the button. In One-Touch Dubbing, programs are automatically dubbed onto the disc from the playback location on the tape. If you want to transfer (dubbing) from the desired point, see "Manual Dubbing" on next page.

*1 Only DVD-RAM and non-finalized DVD-R discs can be used for transfer (dubbing) from a tape. (see page 7.)

Note:

- Copy protected VHS tapes cannot be dubbed to a disc.

Preparation

VCR side:

- Insert a cassette containing material to be dubbed.

DVD side:

- When using a cartridge style disc, confirm that it is not rewrite prohibited.
- Be sure there is enough space on the disc to accommodate the dubbing.
- Select the recording mode. (XP, SP, LP, or EP).
- Disengage the disc protect setting.

■ To end dubbing

Press STOP.

- When playback (source) side ends and unit enters Stop mode, or, if dubbing is stopped due to an error, a message will briefly appear.

■ Only the following operations are allowed while transferring (dubbing)

- Stopping transfer (dubbing) by pressing STOP.
- Changing channels.
 - During dubbing, you can select and watch TV stations using NUMBER keys and Channel ▲▼ keys. To switch back to the dubbing picture, press DVD or VCR. If it is the dubbing picture, CH is not displayed.
- Selecting input mode by pressing INPUT.
- Turning unit ON/OFF by pressing POWER. (Dubbing will continue even if power is turned off.)
- Changing audio mode by pressing AUDIO.

Notes:

- While One Touch Transfer (Dubbing) is activated, timer recording cannot be started.
- When the transfer (dubbing) is not started or not executed, the "DUBBING" indicator blinks for about 7 seconds. Check if the unit is properly prepared.

- When  appears on the screen while a button is being pressed, it means that the corresponding operation is prohibited by the unit or the disc.

Manual Dubbing (Tape → DVD)

RAM DVD-R

You can specify the position to start transfer (dubbing) of the program recorded on the tape to the disc*1.

*1 Only DVD-RAM and non-finalized DVD-R discs can be used for transfer (dubbing) from a tape.

Note:

- Copy protected VHS tapes cannot be dubbed to a disc.

Preparation

VCR side:

- Insert a cassette containing material to be dubbed.
- Select Audio mode. (See page 33.)

DVD side:

- When using a cartridge style disc, confirm that it is not rewrite prohibited.
- Be sure there is enough space on the disc to accommodate the dubbing.
- Place into Record mode.
- Disengage the disc protect setting.

- 1 Set remote to VCR mode.
- 2 Press PLAY. Playback starts. Locate recording start point.
- 3 Press PAUSE at desired dubbing start point.
- 4 Press REC MODE to set recording mode. (Select XP, SP, LP, or EP mode.)
- 5 Press DVD REC. Tape playback starts automatically and dubbing to disc starts. Dubbing information is displayed on the screen and sub display.

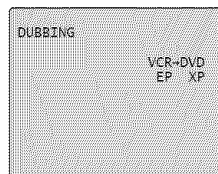

Sub Display

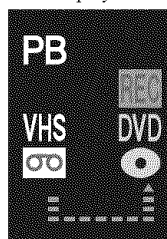

To end dubbing

Press STOP.

- When playback (source) side ends and unit enters Stop mode, or, if dubbing is stopped due to an error, a message will briefly appear.

Only the following operations are allowed while transferring (dubbing)

- Turning unit ON/OFF by pressing POWER.
- Stopping transfer (dubbing) by pressing STOP.
- Selecting input mode by pressing INPUT.
- Changing channels.
 - During dubbing, you can select and watch TV stations using NUMBER keys and Channel ▲▼ keys. To switch back to the dubbing picture, press DVD or VCR. If it is the dubbing picture, CH is not displayed.

Notes:

- While Manual Dubbing (Tape → DVD) is activated, timer recording cannot be started.
- When the transfer (dubbing) is not started or not executed, the "DUBBING" indicator blinks for about 7 seconds. Check if the unit is properly prepared.
- When a Copy-guarded tape is inserted, the message appears on the display and the recording stops on the spot.

Glossary

Bitstream

This is the digital form of multi-channel audio data (e.g., 5.1 channel) before it is decoded into its various channels.

CPRM (Content Protection for Recordable Media)

CPRM is technology used to protect broadcasts that are allowed to be recorded only once. Such broadcasts can be recorded only with CPRM compatible recorders and discs.

Decoder

A decoder restores the coded audio signals on DVDs to normal. This is called decoding.

Dolby Digital

This is a method of coding digital signals developed by Dolby Laboratories. Apart from stereo (2-channel) audio, these signals can also be multichannel audio. A large amount of audio information can be recorded on one disc using this method.

Dolby Pro Logic

A surround system where a 4-channel audio track is recorded as 2 channels and then is restored to 4 channels for play. The surround channel is monaural and can reproduce up to 7 kHz.

Down-mixing

This is the process of remixing the multi-channel audio found on some discs into two channels for stereo output. It is useful when you want to listen to the 5.1-channel audio recorded on DVDs through your television's speakers. Some discs prohibit down-mixing and this unit can then only output the front two channels.

DTS (Digital Theater Systems)

This surround system is used in many movie theaters around the world. There is good separation between the channels, so realistic sound effects are possible.

Dynamic range

Dynamic range is the difference between the lowest level of sound that can be heard above the noise of the equipment and the highest level of sound before distortion occurs. Dynamic range compression means reducing the gap between the loudest and softest sounds. This means you can listen at low volumes but still hear dialog clearly.

Film and video

DVD-Videos are recorded using either film or video. This unit can determine which type has been used, then uses the most suitable method of progressive output.

- Film is 24 or 30 frames per second, with motion picture film generally being 24 frames per second.
- Video is 60 fields per second (two fields making up one frame).

Finalize

A process that makes play of a recorded CD-R, CD-RW or DVD-R etc. possible on equipment that can play such media. You can finalize DVD-R on this unit.

You cannot record onto or edit finalized discs.

Formatting

Formatting is the process of making media such as DVD-RAM recordable on recording equipment. You can format the DVD-RAM on this unit. Formatting erases irrevocably all recordings on the disc.

Frames and fields

Frames refer to the single images that constitute the video you see on your television. Each frame consists of two fields.

- A frame still shows two fields, so there may be some blurring, but picture quality is generally better.
- A field still shows less picture information so it may be rougher, but there is no blurring.

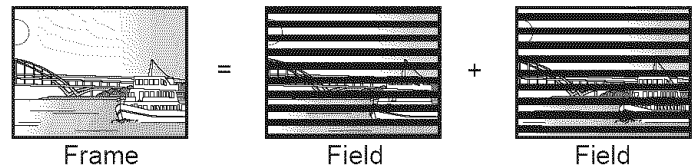

LPCM (Linear pulse code modulation)

These are uncompressed digital signals. This unit outputs linear PCM sound in 2 channels from the DIGITAL AUDIO OUT terminal.

MP3 (MPEG Audio Layer 3)

An audio compression method that compresses audio to approximately one tenth of its size without any considerable loss of audio quality. You can play MP3 you have recorded onto CD-R and CD-RW.

Pan&Scan/Letterbox

In general, DVD-Video are produced with the intention that they be viewed on a widescreen television with an aspect ratio of 16:9. This means you can view most material with the intended aspect ratio on a widescreen television. Material with this ratio will not fit onto a standard television with an aspect ratio of 4:3. Two styles of picture, "Pan&Scan" and "Letterbox", deal with this problem.

Pan&Scan:

The sides are cut off so the picture fills the screen.

Letterbox:

Black bands appear at the top and bottom of the picture so the picture itself appears in an aspect ratio of 16:9.

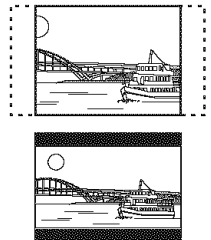

Protection

You can prevent accidental erasure by setting writing protection or erasure protection.

Sampling frequency

Sampling is the process of converting the heights of sound wave (analog signal) samples taken at set periods into digits (digital encoding). Sampling frequency is the number of samples taken per second, so larger numbers mean more faithful reproduction of the original sound.

Subtitles

Written dialogue which appears at the bottom of the screen.

VBR (Variable bitrate)

This is a method of video recording that adjusts the bit rate according to video signal.

Error Messages

These displays will alert you to a missed operation or provide further instructions.

Common

On the Main Display

PLEASE SET CLOCK BY PRESSING ACTION KEY	<ul style="list-style-type: none"> You entered a Timer Recording, On Time, or DVD Menu with the clock not set.
--	---

DVD

On the Main Display

COPYING OF THIS MATERIAL IS NOT ALLOWED CANNOT RECORD	<ul style="list-style-type: none"> The program was copy-guarded.
CANNOT PLAY	<ul style="list-style-type: none"> You inserted an incompatible disc (Discs recorded in PAL video, etc.).
CANNOT RECORD ON THE DISC	<ul style="list-style-type: none"> The disc may be dirty or scratched.
Unable to format.	
PLEASE CHECK THE DISC	
CANNOT RECORD DISC IS FULL	<ul style="list-style-type: none"> Create space by erasing any unwanted titles. RAM Use a new disc. RAM DVD-R
CANNOT RECORD MAXIMUM NUMBER OF TITLES EXCEEDED	
Error has occurred. Please press ENTER.	<ul style="list-style-type: none"> Press ENTER to start recovery process. You cannot operate the unit while it is recovering ("SLF CHECK" appears on the unit's display).
NO DISC	<ul style="list-style-type: none"> You haven't inserted a disc. Correctly insert a disc that this unit can play. The disc is upside down. If it is a single-sided disc, insert it so the label is facing up.
PLEASE CHANGE THE DISC	<ul style="list-style-type: none"> There may be a problem with the disc. Press OPEN/CLOSE to remove it and check it for scratches or dirt.
THIS IS NON-RECORDABLE DISC	<ul style="list-style-type: none"> The unit cannot record on the disc you inserted. Insert a DVD-RAM or unformatted DVD-R. You inserted an unformatted DVD-RAM. Format the disc with this unit.
THIS DISC IS NOT FORMATTED PROPERLY	
PLEASE PREPARE FOR DVD TIMER REC	<ul style="list-style-type: none"> No disc, or a disc that prohibits timer recording is inserted 1 minute prior to timer recording. VCR recording is in progress. The write-protect tab on the cartridge is set to "PROTECT" or the disc is protected with "DISC SETTING".
⊘	<ul style="list-style-type: none"> The operation is prohibited by the unit or disc.

On the Sub Display

HARD ERR	<ul style="list-style-type: none"> If there is no change after turning the unit on and off, consult the dealer where the unit was purchased.
NO READ	<ul style="list-style-type: none"> The disc is dirty or badly scratched. The unit cannot record, play, or edit. You have used a DVD-RAM/PD lens cleaner and it has finished. Press OPEN/ CLOSE to eject the disc.
SLF CHECK	<ul style="list-style-type: none"> There was a power failure or the AC plug was disconnected while the unit was on. The unit is carrying out its recovery process. Wait until the message disappears.
UNSUPPORT	<ul style="list-style-type: none"> You have inserted a disc the unit cannot play or record on.
FULL	<ul style="list-style-type: none"> No space left on the disc. There are already 99 play lists. Delete unnecessary play lists.
U14	<ul style="list-style-type: none"> The unit is hot. The unit switches to standby for safety reasons. Wait for about 30 minutes until the message disappears. Select a position with good ventilation when installing the unit. Do not block the cooling fan on the rear of the unit.
U99	<ul style="list-style-type: none"> The unit fails to operate properly. Press POWER on the main unit to switch the unit to standby. Now press POWER again to turn the unit on.

VHS

On the Main Display

CHECK CASSETTE RECORD TAB	<ul style="list-style-type: none"> If you press REC, and a cassette is inserted with no record tab...
NO CASSETTE	<ul style="list-style-type: none"> If you press PLAY, FF, REW, or REC without a cassette inserted...
PLEASE PREPARE FOR VCR TIMER REC	<ul style="list-style-type: none"> If the unit is not in Stop mode, or cassette is not inserted, or cassette has no record tab, or tape is at its end two minutes before a Timer Recording is about to begin... If DVD recording is in progress...
VIDEO HEADS MAY NEED CLEANING PLEASE INSERT HEAD CLEANING CASSETTE OR REFER TO MANUAL	<ul style="list-style-type: none"> If head cleaning becomes necessary while playing back a tape...
END: PLAY	

Before Requesting Service

Check the following points once again if you are having trouble with your unit.

	PROBLEM	CORRECTION	Page
Power	No power...	Completely insert Power Plug into an AC outlet. Set POWER button to ON.	11 9-10
	Power turns itself off...	Auto power-off (shut off) occurs after about 5 min. in DVD Stop mode with no operation, or if there is no broadcast signal in TV or Playback mode. Turn the power back on.	39, 50
Monitor	No picture or sound...	Make sure your antenna system (TV or CABLE) is correctly set. Completely insert Power Plug into an AC outlet. Set POWER button to ON.	12 11 9-10
	Poor picture with normal sound...	Adjust BRIGHTNESS, SHARPNESS, and PICTURE controls in the SET UP Video Adjustment.	26
	Poor sound with normal picture...	Adjust VOLUME control.	20
	Poor TV reception...	Adjust SHARPNESS and PICTURE controls in the SET UP Video Adjustment.	26
	No color or poor color...	Adjust TINT and COLOR controls in the SET UP Video Adjustment.	26
	Ghost (multiple) images...	Install a directional antenna.	-
	TV programs cannot be watched...	Make sure the selected channel is in unit's memory.	20
	Channel cannot be selected...	Only the channel being recorded can be viewed on this unit.	16-18
	Clock display is flashing 12:00P...	Clock is wrong. Set clock.	16-18
	Front Display is dim...	Check the Front Display setting.	19
	Front display VHS tape counter value does not change...	On a blank section of tape the value stays fixed while the seconds portion is displayed as follows.  Also, if the tape is dirty or damaged, or if unit is malfunctioning, the display above may appear. Please consult your retailer.	-
	Remote Control	Unit cannot be controlled...	Aim Remote directly at the remote sensor on the unit. Avoid any object blocking signal path. Inspect the remote batteries. Exposing unit remote sensor to direct fluorescent or outdoor light may cause signal interference.
ACTION, PLAY, SELECT, SET POWER, etc. buttons cannot be selected...		Press VCR for VCR mode. Press DVD for DVD mode.	9 9
		Check remote batteries.	6
VCR		TV program cannot be recorded...	Make sure your antenna system (TV or CABLE), is correctly set. Make sure cassette record tab is intact.
	Timer recording cannot be performed...	Check that clock is set to current time and date. Make sure DSS/CABLE box (if used) is left on and tuned to channel to be recorded. Set recording Start/Stop times correctly.	16-18 12 30-31
		Timer recording may not be performed or continued if a power interruption of more than 1 minute occurs before or during a Timer Recording, even after power is restored.	
		No playback picture, or the playback picture is noisy or contains streaks...	Adjust TRACKING control in either direction. Try Head Cleaning.

	PROBLEM	CORRECTION	Page
Miscellaneous	Video cassette cannot be inserted...	Insert the cassette window side up; record tab facing you.	28
	Video cassette cannot be removed...	Completely insert Power Plug into an AC outlet.	11
	Eject does not function or insertion cannot be done...	Turn the POWER off and then on, and try ejecting or inserting the tape again.	-
	Video cassette ejects when a recording is started, or the power is turned off for timer recording...	Make sure cassette record tab is intact.	6
	In Stop mode, the VCR motor (CYLINDER) continues to rotate...	To enable Quick Play mechanism, the VCR cylinder will rotate for about 3 minutes. This reduces response time from Stop to Play mode and from Play to Rewind Search mode.	-
	Discs recorded on this unit cannot be played on other equipment...	Discs recorded on this unit must be finalized in order to play them on other equipment.	65
DVD	Play fails to start even when PLAY is pressed...	This unit cannot play discs other than DVDs and CDs.	6-7
		The disc may be dirty and require cleaning.	8
	Picture is distorted during rapid advance or rapid reverse...	The picture will be somewhat distorted at times: this is normal.	-
	No Forward/Reverse search play...	Some discs may have sections which prohibit Forward/Reverse search.	-
	Audio soundtrack and/or subtitle language is not the one selected at the initial settings...	The audio soundtrack and/or subtitle language selected at DVD initial settings must exist on the disc.	55
	No subtitles...	Subtitles appear only when available on disc.	55
		Select "ON" at the "Subtitle language" section to display subtitles.	55
	Alternative audio soundtrack (or subtitle) language cannot be selected...	Alternative language cannot be selected with discs which do not contain more than one language.	55
		For some discs, alternative language cannot be selected with the AUDIO or SUB TITLE button. Try selecting it from the DVD menu if available.	55
	Angle cannot be changed...	This function is dependent on software availability. Even if disc has multiple angles, they may be recorded for specific scenes only.	55
Disc tray will not open with Open/Close button...	In Power OFF condition, hold down both the unit Channel ▲ button and STOP button (DVD side) for 5 seconds.	-	
DVD (Record)	Cannot record...	Make sure disc is inserted and that disc is compatible.	7
		Disable the protect setting on the disc or cartridge.	7
		Record-restricted programs cannot be recorded.	7
		Recording cannot be done on discs which are full or contain the max. number of program (titles). Delete unneeded programs or use new disc.	53, 58, 62, 64
		Disc needs to be formatted. (DVD-RAM)	64
		Recording cannot be done after DVD-R is finalized.	65
		When a disc has been inserted/removed or the power has been turned ON/OFF more than about 50 times, recording or editing may become impossible. (DVD-R)	-
		DVD-R recorded on this unit may not be able to be added to on another brand DVD recorder.	-
Some or all of the recorded program was lost...	If a power outage occurs or the power cord is unplugged, a program could be erased or the disc may become unuseable. Panasonic is not responsible for lost program content or disc malfunction. Format the disc (DVD RAM) or use a new one.	-	

	PROBLEM	CORRECTION	Page
DVD (Edit and Setting)	Even when program (title) is deleted, disc space does not increase...	If PC data, etc. is recorded and deleting titles does not increase disc space, it may be necessary to format disc. (DVD-RAM)	64
		Deletion will not increase disc space. (DVD-R)	7
	Format cannot be done...	If disc is dirty, please purchase a special disc cleaner (LF-K200DCA1, where available) and format after disc is cleaned.	8, 64
		Discs which cannot be formatted may not be useable in this unit.	64
	Chapter cannot be created... Start/End points cannot be set for segment erase...	Created chapter data is written when power is turned off or when disc is removed. If a power outage, etc. disrupts this process, chapter information may not be recorded.	54
Start/End points cannot be set if the space between them is too short, or if the Start point comes after the End point. Start/End points cannot be set on a paused picture.		58, 62	
Chapter cannot be deleted...	If the chapter is too short to be erased, combine it with another chapter and then erase.	59, 62	
Dubbing	Cannot dub from video tape to disc... Cannot dub from disc to video tape...	Most videos and DVDs on the market (including rentals) are copy protected and cannot be correctly copied.	-
	The audio level of DVD side and VHS side is different after dubbing...	On some discs, the audio level is not uniform. If certain parts, such as speech, etc. are set to higher or lower audio levels, then recorded onto a tape, this condition may be produced.	-

If you cannot resolve the problem, please call the Customer Satisfaction Center for product assistance at 1-800-211-PANA(7262). To locate an authorized servicer call toll free 1-800-211-PANA(7262) or, contact us via the web at:<http://www.panasonic.com/contactinfo>

Q & A

Question	Answer
I want to enjoy 5.1 Ch surround sound of dolby digital, DST, etc. What equipment do I need?	<ul style="list-style-type: none"> This unit alone is not enough. You will need 6 speakers and, if a digital connection, an amp equipped with dolby digital or DST recorder.
Can I play DVD-Video purchased abroad?	<ul style="list-style-type: none"> You can play them if the video standard is NTSC. Only if the regional code includes "ALL" or "1". Check the package.
Can a DVD-Video that does not have a region number be played?	<ul style="list-style-type: none"> The DVD-Video region number indicates the disc conforms to a standard. You cannot play discs that do not have a region number.
Can I use DVD-R and DVD-RW in this unit?	<ul style="list-style-type: none"> Only a DVD-R that has been finalized can be used. DVD-RW cannot be used. This unit also records and plays 1x-4x recording speed DVD-R discs.
Can I use CD-R and CD-RW in this unit?	<ul style="list-style-type: none"> CD-R and CD-RW recorded with finalized MP3 music will play. However, this unit does not allow CD-R and CD-RW recording.
Can I record from a video or outside DVD source?	<ul style="list-style-type: none"> Most video tape and DVD titles on the market are copy protected. In this case, recording is not possible.
Can I play DVD-Rs recorded on this unit on other machines?	<ul style="list-style-type: none"> Once a DVD-R recorded on this unit is finalized, it can be played on other DVD-R compatible machines. (It is not guaranteed to work with all machines.) It may not play depending on recording conditions.
Can I record digital audio signals on this unit?	<ul style="list-style-type: none"> This is not possible.
Can I record from a commercially purchased video cassette or DVD?	<ul style="list-style-type: none"> Most commercially sold video cassettes and DVD are copy protected; therefore, recording is usually not possible.
Can a digital audio signal from this unit be recorded to other equipment?	<ul style="list-style-type: none"> You can record if using the PCM signal. When recording DVD, change the "Digital Audio Output" settings to the following in the SETUP menu. <ul style="list-style-type: none"> - PCM Down Conversion: On - Dolby Digital: PCM - DTS: PCM However, only as long as digital recording from the disc is permitted and the recording equipment is compatible with a sampling frequency of 48 kHz.
How many times can I rewrite a DVD-RAM?	<ul style="list-style-type: none"> This varies based on conditions of usage, but they can be rewritten up to about 100,000 times.

Specifications

Display		
Picture Tube	27 inch, measured diagonally pure flat Picture Tube	
VCR		
Video Recording System	4 rotary heads helical scanning system	
Audio Track	1 track (Normal) 2 channel (Hi-Fi Audio Sound)	
Tuner		
Broadcast Channels	VHF 2 ~ 13, UHF 14 ~ 69	
CABLE Channels	Midband A through I (14 ~ 22) Superband J through W (23 ~ 36) Hyperband AA ~ EEE (37 ~ 64) Lowband A-5 ~ A-1 (95 ~ 99) Special CABLE channel 5A (01) Ultraband 65 ~ 94, 100 ~ 125	
General		
Power Source	120 V AC, 60 Hz	
Power Consumption	Power On	Approx. 161 W
	Power Off	Approx. 0.9 W
Television System	EIA Standard NTSC color	
Speaker	2 pieces 5 W	
Operating Temperature	5 °C ~ 35 °C (41 °F ~ 95 °F)	
Operating Humidity	10 % ~ 75 %	
Weight	49 kg (108.0 lbs.)	
Dimensions (W x H x D)	760 mm (29-7/8") x 645 mm (25-3/8") x 511 mm (20-1/8")	
Recording discs		
DVD-RAM	12 cm (5") 4.7 GB, 12 cm (5") 9.4 GB, 8 cm (3") 2.8 GB	
DVD-R	12 cm (5") 4.7 GB, 8 cm (3") 1.4 GB (for General Ver. 2.0) 12 cm (5") 4.7 GB (for General Ver. 2.0/4x-SPEED DVD-R Revision 1.0)	
Playable discs		
DVD-RAM	12 cm (5") 4.7 GB, 12 cm (5") 9.4 GB, 8 cm (3") 2.8 GB	
DVD-R	12 cm (5") 4.7 GB, 8 cm (3") 1.4 GB (for General Ver. 2.0) 12 cm (5") 4.7 GB (for General Ver. 2.0/4x-SPEED DVD-R Revision 1.0)	
DVD-Video		
CD-Audio (CD-DA)		
CD-R/RW (MP3, CD-DA formatted discs)		
Digital audio output		
Optical digital output	Optical connector	
Pickup		
Wavelength	655 nm (DVD) 790 nm (CD) Laser power: CLASS II	

Note:

- Designs and specifications are subject to change without notice.

Limited Warranty

PANASONIC CONSUMER ELECTRONICS COMPANY, DIVISION
OF MATSUSHITA ELECTRIC CORPORATION OF AMERICA
One Panasonic Way Secaucus, New Jersey 07094

PANASONIC SALES COMPANY, DIVISION OF MATSUSHITA
ELECTRIC OF PUERTO RICO, INC.,
AVE. 65 de Infantería, Km. 9.5 San Gabriel Industrial Park,
Carolina, Puerto Rico 00985

Panasonic/Quasar Video Products Limited Warranty

Limited Warranty Coverage

If your product does not work properly because of a defect in materials or workmanship, Panasonic Consumer Electronics Company or Panasonic Sales Company (collectively referred to as "the warrantor") will, for the length of the period indicated on the chart below, which starts with the date of original purchase ("warranty period"), at its option either (a) repair your product with new or refurbished parts, or (b) replace it with a new or a refurbished product. The decision to repair or replace will be made by the warrantor.

Product	Parts	Labor	Service	Contact Number
Camcorder	One (1) Year (except CCD Image Sensor) CCD Image Sensor - 6 (Six) Months	Ninety (90) Days Ninety (90) Days	Carry-In or Mail-In	1-800-211-PANA(7262)
DVD/VCR Deck, A/V Mixer	One (1) Year	Ninety (90) Days	Carry-In or Mail-In	1-800-211-PANA(7262)
TV/VCR, TV/DVD, TV/DVD/VCR Combination	One (1) Year (except CRT) CRT - Two (2) Years	Ninety (90) Days Ninety (90) Days	Carry-In: 21" CRT and Smaller In-Home or Carry-In: 22" CRT and Larger	1-800-211-PANA(7262)
TV/HDR Combination	One (1) Year (except CRT) CRT - Two (2) Years	Ninety (90) Days Ninety (90) Days	In-Home or Carry-In	1-888-843-9788
Rechargeable Batteries (in exchange for defective item)	Ten (10) Days	Not Applicable	Carry-In or Mail-In	1-800-211-PANA(7262)
Tape (in exchange for defective item)	Five (5) Days	Not Applicable	Carry-In or Mail-In	1-800-211-PANA(7262)
Memory Cards (in exchange for defective item)	Ninety (90) Days	Not Applicable	Carry-In or Mail-In	1-800-211-PANA(7262)

During the "Labor" warranty period there will be no charge for labor. During the "Parts" warranty period, there will be no charge for parts. You must carry-in or mail-in your product or arrange for in-home service, as applicable, during the warranty period.

If non-rechargeable batteries are included, they are not warranted. This warranty only applies to products purchased and serviced in the United States or Puerto Rico. This warranty is extended only to the original purchaser of a new product which was not sold "as is". A purchase receipt or other proof of the original purchase date is required for warranty service.

Carry-In, Mail-in or In-Home Service

For Carry-In, Mail-In or In-Home Service (as applicable) in the United States call toll free contact number listed above or visit Panasonic Web Site: <http://www.panasonic.com>

For assistance in Puerto Rico call Panasonic Sales Company (787)-750-4300 or fax (787)-768-2910.

In-Home service, if applicable, requires clear, complete and easy access to the product by the authorized servicer and does not include removal or re-installation of an installed product. It is possible that certain in-home repairs will not be completed in-home, but will require that the product, or parts of the product, be removed for shop diagnosis and/or repair and then returned.

Limited Warranty Limits And Exclusions

This warranty ONLY COVERS failures due to defects in materials or workmanship, and DOES NOT COVER normal wear and tear or cosmetic damage, nor does it cover markings or retained images on the picture tube resulting from viewing fixed images (including, among other things, letterbox pictures on standard 4:3 screen TV's, or non-expanded standard 4:3 pictures on wide screen TV's, or onscreen data in a stationary and fixed location). The warranty ALSO DOES NOT COVER damages which occurred in shipment, or failures which are caused by products not supplied by the warrantor, or failures which result from accidents, misuse, abuse, neglect, mishandling, misapplication, alteration, faulty installation, set-up adjustments, misadjustment of consumer controls, improper maintenance, power line surge, lightning damage, modification, or commercial use (such as in a hotel, office, restaurant, or other business), rental use of the product, service by anyone other than a Factory Servicenter or other Authorized Servicer, or damage that is attributable to acts of God.

THERE ARE NO EXPRESS WARRANTIES EXCEPT AS LISTED UNDER "LIMITED WARRANTY COVERAGE". THE WARRANTOR IS NOT LIABLE FOR INCIDENTAL OR CONSEQUENTIAL DAMAGES RESULTING FROM THE USE OF THIS PRODUCT, OR ARISING OUT OF ANY BREACH OF THIS WARRANTY. (As examples, this excludes damages for lost time, cost of having someone remove or re-install an installed unit if applicable, or travel to and from the servicer, loss of media or images, data or other memory or recorded content. The items listed are not exclusive, but are for illustration only.)

ALL EXPRESS AND IMPLIED WARRANTIES, INCLUDING THE WARRANTY OF MERCHANTABILITY, ARE LIMITED TO THE PERIOD OF THE LIMITED WARRANTY.

Some states do not allow the exclusion or limitation of incidental or consequential damages, or limitations on how long an implied warranty lasts, so the exclusions may not apply to you.

This warranty gives you specific legal rights and you may also have other rights which vary from state to state. If a problem with this product develops during or after the warranty period, you may contact your dealer or Servicer. If the problem is not handled to your satisfaction, then write to the warrantor's Consumer Affairs Department at the addresses listed for the warrantor.

PARTS AND SERVICE (INCLUDING COST OF AN IN-HOME SERVICE CALL, WHERE APPLICABLE) WHICH ARE NOT COVERED BY THIS LIMITED WARRANTY ARE YOUR RESPONSIBILITY.

Customer Services Directory

Obtain Product Information and Operating Assistance; locate your nearest Dealer or Servicer; purchase Parts and Accessories; or make Customer Service and Literature requests by visiting our Web Site at:

<http://www.panasonic.com/support>

or, contact us via the web at:

<http://www.panasonic.com/contactinfo>

You may also contact us directly at:

**1-800-211-PANA (7262),
Monday-Friday 9 am-9 pm; Saturday-Sunday 10 am-7 pm, EST.**

For hearing or speech impaired TTY users, TTY : 1-877-833-8855

Accessory Purchases

Purchase Parts, Accessories and Instruction Books online for all Panasonic Products by visiting our Web Site at:

<http://www.pasc.panasonic.com>

or, send your request by E-mail to:

npcparts@panasonic.com

You may also contact us directly at:

1-800-332-5368 (Phone) 1-800-237-9080 (Fax Only) (Monday – Friday 9 am to 8 pm, EST.)

Panasonic Services Company

20421 84th Avenue South,

Kent, WA 98032

(We Accept Visa, MasterCard, Discover Card, American Express, and Personal Checks)

For hearing or speech impaired TTY users, TTY : 1-866-605-1277

Service in Puerto Rico

Matsushita Electric of Puerto Rico, Inc. Panasonic Sales Company

Factory Servicer:

Ave. 65 de Infanteria, Km. 9.5, San Gabriel Industrial Park, Carolina, Puerto Rico 00985

Phone (787)750-4300 Fax (787)768-2910

Guía rápida de uso en español

Conexión

Notas sobre las conexiones

- Desconecte la alimentación de todos los componentes antes de realizar cualquier conexión.
- Si los cables necesarios para conectar un componente al sistema no están incluidos con el componente o disponibles opcionalmente, quizás deba adoptar un cable para que se adecue al componente involucrado.
- Consulte cuidadosamente el manual de instrucciones de cada componente del sistema antes de conectarlo.

Conexión del terminal de entrada RF

⚠ PRECAUCIÓN

Apretar demasiado los cables coaxiales RF "tipo tuerca" podría dañar los conectores. Asegúrelos solamente con los dedos.

■ Conexión de la antena

Conecte el cable de la antena al terminal VHF/UHF de la unidad.

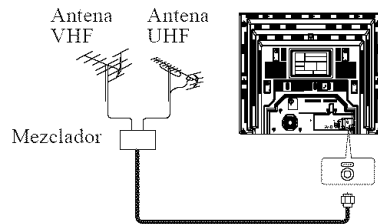

■ Conexión del cable

Conecte el cable suministrado por la compañía de cable local al terminal VHF/UHF de la unidad.

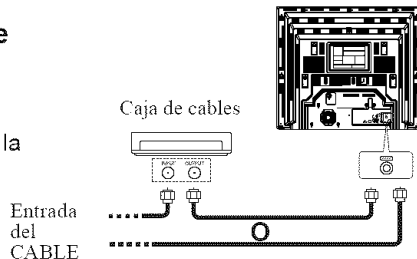

Nota para el instalador del sistema de CABLE:

Este recordatorio tiene la finalidad de llamar la atención a los instaladores del sistema de CABLE (televisión por cable) sobre el artículo 820-40 de NEC que brinda pautas para una conexión a tierra apropiada y, en particular, especifica que la tierra del cable se deberá conectar al sistema de tierra del edificio, tan cerca del punto de ingreso del cable como sea práctico.

Conexión del terminal de entrada AV

Conecta videograbadores y otros equipos periféricos

■ Se usa el terminal Video

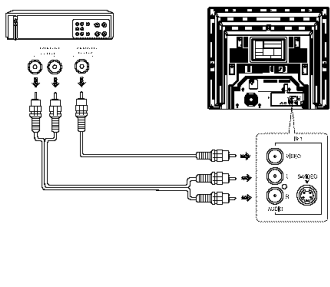

■ Se usa el terminal S-Video

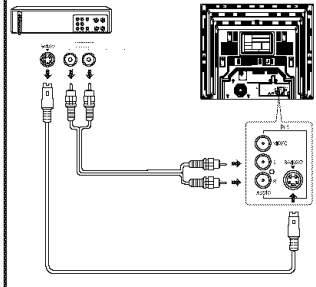

Funcionamiento del televisor

Configuración inicial (listo para reproducir)

Por favor realice todas las conexiones del cable o antena antes de conectar la alimentación.

Enchufe el cable de alimentación de la unidad en un tomacorriente de ca.

1 Presione POWER en el control remoto o unidad. Comienza el ajuste automático de reloj y canal.

- Si usa una caja de cables, debe encenderla y ajustarla al canal de servicio de difusión pública (PBS) en su zona horaria. Si usa un receptor DSS, éste debe estar apagado.

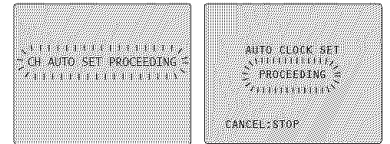

- Los botones de funciones no funcionarán durante la configuración inicial.
- Para expulsar una cinta durante la configuración automática, presione dos veces el botón STOP/EJECT de la unidad.
- Dependiendo de las condiciones, el ajuste automático de reloj podría llevar más de 30 minutos. En tal caso, presione STOP para detener la configuración y realizar los ajustes manualmente.

Caso 1

Los ajustes se realizan automáticamente. Cuando se termina la configuración, aparecerá la siguiente pantalla.

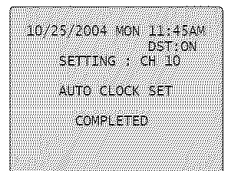

Caso 2

Si la configuración no está completa, aparecerá la siguiente pantalla. Verifique la conexión de la antena/cable al terminal de entrada RF, luego pruebe ajustar manualmente el reloj de la siguiente manera.

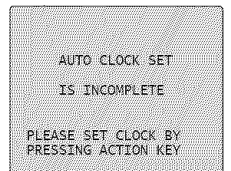

a. Presione ACTION del control remoto para exhibir la pantalla de menú SET CLOCK.

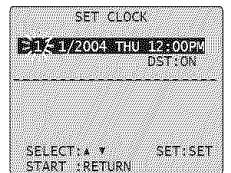

b. Presione ▲▼ para seleccionar el mes y presione SET para ajustarlo. De la misma manera, seleccione y ajuste la fecha, año, hora, y DST (hora de verano).

- Presione ◀ repetidamente para mover el cursor. Presione ▲▼ para realizar la corrección.

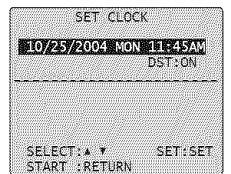

c. Presione RETURN dos veces para arrancar el reloj y salir.

Selección del modo de entrada

Método 1:

Presione CH ▲▼. La exhibición cambiará de la siguiente manera.

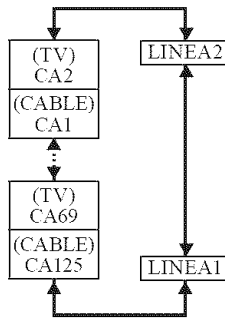

Método 2:

Presione INPUT. La exhibición cambiará de la siguiente manera.



LINEA1:

Se exhibe la señal de la fuente conectada al terminal de entrada AV1.

LINEA2:

Se exhibe la señal de la fuente conectada al terminal de entrada AV2.

SINTONIZADOR:

Se exhibe la señal de la fuente conectada al terminal VHF/UHF.

Uso de la tecla Number y 100

Cuando esté seleccionando canales de CABLE del 100 al 125 con las teclas NUMBER, primero presione la tecla 100, y luego ingrese los dos dígitos restantes.

Ejemplo:

Para seleccionar el canal 125, primero presione la tecla 100, luego 2, luego 5.

Sintonización rápida

Presione R-TUNE para exhibir el último canal que estaba mirando.

Apagado del audio

Presione MUTE para apagar instantáneamente el sonido. Presione de nuevo para restaurar el sonido a su nivel anterior.

Funcionamiento del videograbador

Grabación de una cinta

- 1 **Inserte una cinta con marca de grabación.**
 - La alimentación de la unidad se conecta automáticamente.
- 2 **Presione CH ▲▼ o las teclas NUMBER para seleccionar el canal.**
- 3 **Presione SPEED para seleccionar la velocidad de grabación.**

SP = Reproducción estándar.
EP = Extra Long Pkay

• Se exhibe la velocidad seleccionada.

4 Presione VCR REC para comenzar la grabación.

• No puede visualizar otro canal durante la grabación.

Grabación de un toque (OTR)

Presione VCR REC repetidamente para ajustar la duración de la grabación (30 minutos - 4 horas.)

• La unidad detiene la grabación a la hora preajustada.

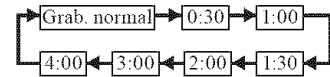

■ Pausar una grabación

- a. Presione PAUSE.
- b. Presione PAUSE para retomar la grabación.

■ Detención de una grabación

- a. Presione STOP para detener la grabación.

Notas:

- Después de que la unidad ha estado en el modo de pausa de grabación por cinco minutos, se detendrá automáticamente para proteger la cinta y el cabezal de vídeo.
- El tiempo de grabación restante de la grabación de un toque se puede exhibir presionando DISPLAY.
- Cuando la Grabación de un toque (OTR) esté en pausa, el tiempo de pausa también se incluirá en la longitud total de la grabación.

Grabación con temporizador

Puede establecer que sean grabados hasta ocho programas mientras usted está fuera.

1 Presione PROG/CHECK para exhibir la pantalla "FIJAR TEMPORIZADOR".

2 Presione ◀▶ para seleccionar "VCR".

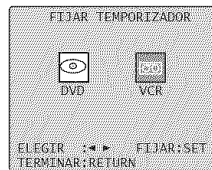

3 Presione SET para exhibir la pantalla.

• Si un programa ya está en la memoria, presione ▲▼, y SET para seleccionar un número de programa no usado.

4 Presione ▲▼ para seleccionar y SET o ◀▶ para ajustar la fecha de grabación.

- 1~31 = una vez
- DIARIO = diariamente de lunes a viernes
- SEMANAL = semanalmente de domingo a sábado (a la misma hora una vez a la semana)



Ejemplo:

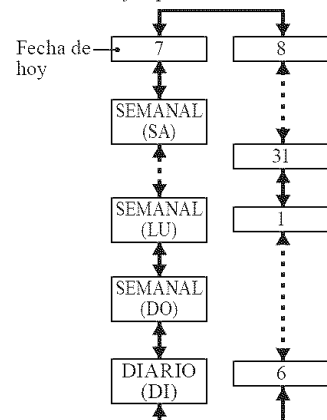

■ Repita el paso 4 para ajustar:

- Hora de comienzo, hora de detención
- Canal (o LINEA para una fuente del exterior)
- Velocidad (SP, EP)

Véase la página siguiente..

- 5** Presione RETURN para terminar el programa. Para ingresar más programas, presione ▲ ▼ para seleccionar y SET para ajustar un número de programa vacío, y luego repita el paso 4.

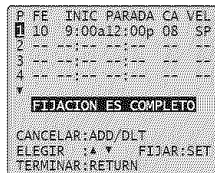

- 6** Presione RETURN dos veces para salir de este modo.

- Si está usando una caja de cables, asegúrese de que esté sintonizada en el canal deseado y de que la alimentación se deje conectada para la grabación con temporizador.

■ **Para reemplazar el programa...**

- Presione ▲ ▼ para seleccionar el programa deseado.
- Presione SET para exhibir.
- Presione ▲ ▼ para seleccionar y presione SET o ◀▶ para ajustar un programa nuevo.
- Presione RETURN.

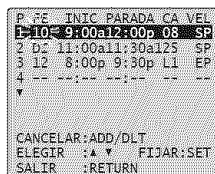

■ **Para borrar un programa...**

- Presione ▲ ▼ para seleccionar el programa deseado.
- Presione ADD/DLT.

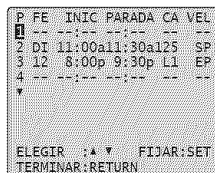

■ **Cancelar una grabación con temporizador: (Grabación en progreso)**

- Mantenga presionado STOP por algunos segundos para cancelar la grabación con temporizador.
 - Cualquier grabación diaria o semanal se realizará como estaba programado.

Nota:

- Si la hora de grabación con temporizador del disco (DVD-RAM, DVD-R) y del VCR se superponen, el que tenga la hora de inicio de grabación anterior tendrá prioridad. Si las horas de inicio coinciden, el lado el disco tendrá prioridad.

Reproducción de una cinta

1 Inserte una cinta.

- La alimentación de la unidad se conecta automáticamente.

2 Presione PLAY para reproducir una cinta.

- Si la cinta no tiene marca de grabación, comienza la reproducción automática.

■ **Búsqueda de escena hacia adelante o atrás**

- Presione FF/SLOW+ o REW/SLOW-.
- Presione de nuevo o PLAY para cancelar. Una vez comenzada la búsqueda, cada presión adicional de FF o REW cambia la velocidad.
- La velocidad de búsqueda de FF y REW puede variar dependiendo de la posición actual de la cinta.

■ **Imagen fija (congelar)**

- Presione PAUSE.
- Presione PLAY para cancelar.

■ **Imágenes en cámara lenta**

- Presione FF/SLOW+ (aumenta la velocidad) o REW/SLOW- (disminuye la velocidad) en el modo de imagen fija.
- Presione PLAY para cancelar.

■ **Imágenes cuadro a cuadro**

- Presione PAUSE en el modo de imagen fija.
- Presione PLAY para cancelar.

Detención de una cinta

1 Presione STOP.

■ **Rebobinado rápido de una cinta**

- Presione REW/SLOW- en el modo de detención. Rebobina una cinta T-120 en aproximadamente 1 minuto.

■ **Avance de la cinta rápido hacia adelante**

- Presione FF/SLOW+ en el modo de detención.

■ **Expulsión de la cinta**

- Presione EJECT en el control remoto o STOP/EJECT en la unidad.

Funcionamiento del disco

Discos que sólo se pueden reproducir

Tipo de disco	Logotipo del disco	Instrucciones	Indicación en estas instrucciones de funcionamiento
DVD de vídeo		Discos de películas y música de alta calidad	DVD-V
CD		Audio y música grabados (incluyendo CD-R/RW) CD-R y CD-RW con música grabada en MP3 (pág. 87)	CD (CD-DA) o MP3 (MP3)

Discos que pueden grabarse y reproducirse

Tipo de disco	Logotipo del disco	Indicación en estas instrucciones de funcionamiento
DVD-R		DVD-R
DVD-RAM		RAM

- Finalice* el disco después de grabarlo.

*Proceso que permite reproducir discos en equipos compatibles. (Consulte la página 88.)

Introducción de un disco

- 1 Presione **OPEN/CLOSE** en la unidad para abrir la bandeja e introducir un disco.

- Presione el botón de nuevo para cerrar la bandeja.



Grabación de un disco

RAM DVD-R

- En los discos de dos caras, no es posible grabar de manera continua desde una cara a la otra. Deberá expulsar el disco y darle la vuelta.
- Cuando utilice DVD-RAM de 8 cm, saque el disco del cartucho.
- Podrá grabar hasta 99 títulos en un solo disco.
- Es posible grabar emisiones digitales que permiten "grabación única" al utilizar discos DVD-RAM compatibles con CPRM. Y no será posible grabar emisiones digitales que permitan "grabación única" al utilizar DVD-R.
- Los DVD-RAM/DVD-R tienen limitaciones de grabación.
- No se pueden grabar discos DVD-R finalizados.
- La grabación se realizará en el espacio disponible del disco. Los datos no se sobrescribirán.

- 1 Presione **OPEN/CLOSE** en la unidad para abrir la bandeja e introducir un disco.
- 2 Presione las teclas **CH ▲ ▼** o las teclas numéricas para seleccionar el canal.

■ Para seleccionar con las teclas numéricas (NUMBER):

Modo de TV (ondas aéreas)

p. ej. 5: [5]
15: [1] → [5]

Modo CATV (cable)

p. ej. 5: [5]
15: [1] → [5]
115: [tecla 100] → [1] → [5]

- 3 Presione **REC MODE** para seleccionar el modo de grabación (XP, SP, LP o EP).

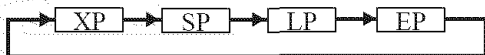

- 4 Presione **DVD REC** para iniciar la grabación.
- Para especificar una hora para detener la grabación

Durante la grabación

Presione **DVD REC** en la unidad o en el control remoto para seleccionar la hora de grabación.

Cada vez que presione el botón:

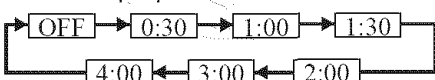

- Para detener la grabación

Presione **STOP**.

- Se grabará como un título hasta la posición donde se detiene.
- **DVD-R** DVD-R la unidad tardará aproximadamente 30 segundos en completar la información de gestión de la grabación cuando ésta haya finalizado.

- Para realizar una pausa durante la grabación

Presione **PAUSE**.

Presione **PAUSE** de nuevo para reanudar la grabación.

Grabación con temporizador

RAM DVD-R

- 1 Presione **PROG/CHECK** para mostrar la pantalla "FIJAR TEMPORIZADOR".
- 2 Presione **◀ ▶** para seleccionar "DVD".
- 3 Presione **▲ ▼** para seleccionar "Nuevo programa" y a continuación, presione **ENTER**.

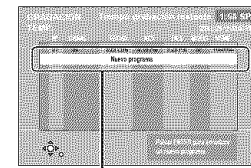
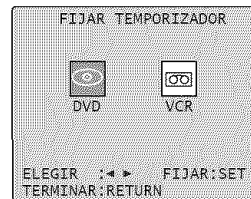

La línea resaltada estará preparada para la programación.

- 4 Presione **▶** para desplazarse por las diferentes opciones y cámbielas pulsando los botones **▲ ▼**.

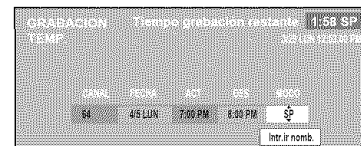

FECHA

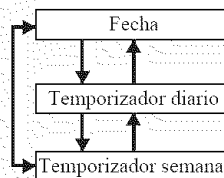

Fecha actual hasta un mes más tarde menos un día

DOM-SAB → LUN-SAB → LUN-VIE

DOM SEMANAL → SAB SEMANAL

- 5 Presione **ENTER**

- Repita los pasos 3-5 para programar otras grabaciones.

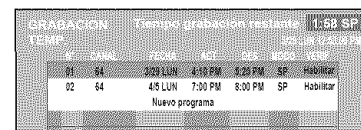

- 6 Presione **RETURN**

- "Ⓞ" se iluminará en el panel delantero para indicar que se ha activado el modo de espera de la grabación con temporizador.

- Para cancelar la grabación cuando ya se ha iniciado

Mantenga presionado el botón **STOP** durante unos segundos.

Reproducción durante una grabación

RAM DVD-R	
Reproducción con preselección	Puede empezar a reproducir desde el comienzo del título que está grabando. Pulse ► (PLAY). El indicador de salto hacia atrás de la unidad principal se enciende.
Grabación y reproducción simultáneas	Puede reproducir un título grabado previamente. 1 Pulse DIRECT NAVIGATOR. 2 Pulse ▲▼◀▶ para seleccionar un título y pulse ENTER. • Para salir de la pantalla Direct Navigator Pulse DIRECT NAVIGATOR.
Time Slip Nota: La función Time Slip (grabación y reproducción simultáneas) no estará disponible si se ha realizado algún ajuste en el chip antiviolencia (V-Chip) en la opción de BLOQUEO del menú principal.	Puede revisar las imágenes grabadas mientras graba. 1 Pulse TIME SLIP. 2 Pulse ▲▼ para seleccionar el tiempo y pulse ENTER. • Pulse TIME SLIP para mostrar las imágenes de reproducción completas. Pulse de nuevo para mostrar las imágenes de reproducción y grabación.

Procedimiento de reproducción de discos

RAM DVD-R DVD-V CD MP3				
------------------------	--	--	--	--

- Presione OPEN/CLOSE en la unidad para abrir la bandeja e introducir un disco.**
 - Presione el botón de nuevo para cerrar la bandeja.
 - Presione PLAY/×1.3**
 - La unidad tardará un cierto tiempo en leer el disco antes de iniciar la reproducción.
- **Detener la reproducción**
Presione STOP.
- Presione STOP de nuevo para volver a la pantalla de televisión.
- DVD-V CD MP3**
- Cuando el mensaje "PB" parpadee en la pantalla delantera, la función de reanudación estará activada.
 - El protector de pantalla puede aparecer cuando se detiene la reproducción. Presione STOP de nuevo y podrá utilizar el sintonizador de esta unidad para ver televisión.
- **Pausar la reproducción**
Presione PAUSE.
- Presione PAUSE de nuevo para reanudar la reproducción

Iniciar la reproducción desde el punto en que se detuvo (función de reanudación)

RAM DVD-R DVD-V CD MP3				
------------------------	--	--	--	--

- Presione STOP durante la reproducción.**
 - El mensaje "PB" parpadea en la pantalla de la unidad (únicamente en la reproducción normal). La unidad memorizará la posición.
 - Presione PLAY/×1.3**
 - La reproducción se iniciará desde el punto en que se detuvo.
- **Para cancelar la función de reanudación (sólo en reproducción normal)**
Presione STOP mientras la unidad recuerda la posición. (La posición también se borrará cuando apague la unidad o abra la bandeja del disco.)

Selección de programas grabados (títulos) para reproducirlos

RAM DVD-R	
-----------	--

- Presione DIRECT NAVIGATOR.**
- Presione ▲▼◀▶ para seleccionar el título y presione ENTER.**
 - También puede seleccionar títulos con las teclas de número.

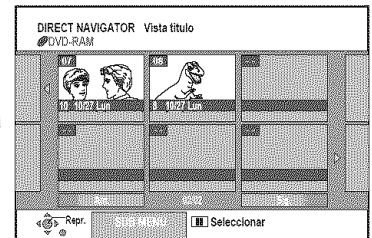

Por ejemplo, 5: [0] → [5] 15: [1] → [5]

- Si introduce un número mayor que el número total de títulos, se seleccionará el último título.

■ **Para detener la reproducción**

Presione STOP.

■ **Para salir de la pantalla**

Presione RETURN o DIRECT NAVIGATOR.

Iconos de la pantalla de DIRECT NAVIGATOR

- 🔒: Título protegido.
- 🔒: Título que no se grabó durante la protección de grabación (emisiones digitales, etc.).
- ✗: Título que no puede reproducirse porque los datos están dañados.
- : Grabando actualmente.

Inicio desde un elemento seleccionado

RAM DVD-R DVD-V CD MP3				
------------------------	--	--	--	--

Iniciar la reproducción desde un título, capítulo o pista seleccionados.

- Presione las teclas numéricas para seleccionar el elemento durante la reproducción o cuando esté detenida.**

p. ej. 5: [0] → [5]
15: [1] → [5]

MP3
p. ej. 5: [0] → [0] → [5]
15: [0] → [1] → [5]
115: [1] → [1] → [5]

Saltar pistas

RAM DVD-R DVD-V CD MP3				
------------------------	--	--	--	--

- Presione SKIP ►► o SKIP ◀◀ durante la reproducción o en el modo de pausa.**

- En la unidad, presione ►► o ◀◀.
- Cada vez que presione estos botones, el número de saltos se incrementará.

Avance rápido y rebobinado (búsqueda)

RAM DVD-R DVD-V CD MP3				
------------------------	--	--	--	--

- Presione ►► FF/SLOW o ◀◀ REW/SLOW durante la reproducción.**

- Presione los botones ►► o ◀◀ de la unidad y manténgalos presionados.
- La velocidad se incrementará hasta un máximo de 5 pasos.
- Presione PLAY/×1.3 para volver a la velocidad normal.

Reproducción en cámara lenta

RAM DVD-R DVD-V

- 1 Presione **▶▶ FF/SLOW** o **◀◀ REW/SLOW** con la reproducción en pausa.
 - Presione los botones **▶▶** o **◀◀** de la unidad y manténgalos presionados.
 - Cuando la reproducción en cámara lenta continúa durante aproximadamente 5 minutos, se pondrá en pausa automáticamente.

■ Para volver a la velocidad normal

Presione **PLAY** ×1.3.

Visualización fotograma a fotograma

RAM DVD-R DVD-V

- 1 Presione **FRAME II▶** o **FRAME ◀II** con la reproducción en pausa.

■ Para volver a la velocidad normal

Presione **PLAY** ×1.3.

Avanzar un minuto (salto CM)

RAM DVD-R

- 1 Presione **CM/ZERO** durante la reproducción.
 - La reproducción se reanudará al cabo de aproximadamente un minuto.

Nota:

- Si el inicio del programa siguiente está dentro de un minuto desde el punto en que saltó, la reproducción se reiniciará desde el principio de ese programa.

Vista rápida

RAM (Sólo con Dolby Digital)

La velocidad de reproducción puede incrementarse sin distorsionar el audio.

- 1 Presione **PLAY** ×1.3 y manténgalo presionado durante la reproducción.

■ Para volver a la velocidad normal

Presione **PLAY** ×1.3.

Saltar hasta la hora especificada (Time Slip)

RAM

- 1 Presione **TIME SLIP** durante la reproducción.

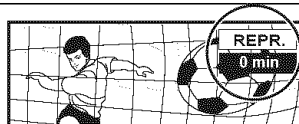

- 2 Presione **▲▼** para seleccionar la hora mientras se muestra la indicación.

- El indicador de tiempo se apagará al cabo de 5 segundos, pero se volverá a encender cuando configure el indicador.
- Presione **▲▼** para cambiar el tiempo en unidades de un minuto. Presione **▲▼** y manténgalos presionados para cambiar el tiempo en unidades de 10 minutos.

- 3 Presione **ENTER**.

- La reproducción saltará hasta la hora especificada.

Utilizar menús para reproducir MP3

MP3

Esta unidad puede reproducir archivos MP3 grabados en CD-R/RW con un computador. Los archivos tratados como pistas y carpetas se tratarán como grupos.

- 1 Presione **TOP MENU** durante la reproducción o el modo detenido.

G: Grupo n.º

T: n.º de pista en el grupo

TOTAL: n.º de pista/n.º total de pistas en todos los grupos

Grupo seleccionado

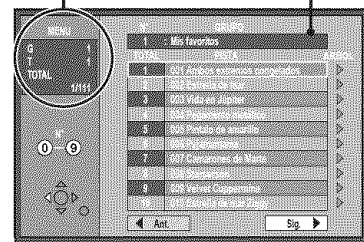

Caso 1

- Utilizar la pantalla con estructura de árbol para encontrar un grupo

- a Presione **▶** para visualizar la pantalla con estructura de árbol mientras se muestra la lista de archivos.

Presione **▲▼◀▶** para seleccionar un grupo y presione **ENTER**.

- Aparecerá la lista de archivos del grupo.

N.º de grupos seleccionado/n.º total de grupos.

Si el grupo no tiene ninguna pista, se mostrará " " como número de grupo.

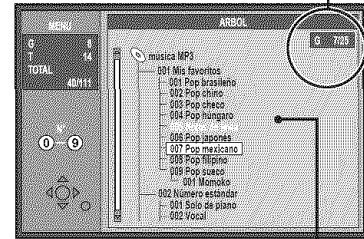

No podrá seleccionar grupos que contengan archivos no compatibles.

Caso 2

- Utilizar la pantalla con estructura de árbol para encontrar una pista.

- a Presione **▲▼** para seleccionar la pista y presione **ENTER**.

- La reproducción seguirá hasta la última pista en el último grupo.
- "□" indica la pista que se está reproduciendo.
- También puede seleccionar la pista con las teclas numéricas.

p. ej. 5: [0] → [0] → [5]

15: [0] → [1] → [5]

115: [1] → [1] → [5]

■ Para mostrar otras páginas

Presione **▶** para seleccionar "Ant." o "Sig" y presione **ENTER**.

- Después de especificar en una lista todas las pistas de un grupo, aparecerá la lista del grupo siguiente.

■ Para salir de la pantalla

Presione **RETURN** o **TOP MENU**.

Formatear un disco

RAM

Notas:

- El formateo borra todo el contenido de un disco, incluyendo los datos del computador. Compruébelos cuidadosamente antes de formatear.
- Algunos DVD-RAM no tienen formato. Formatéelos antes de utilizarlos en esta unidad. El formateo también le permite borrar todo el contenido de un disco.

1 Presione ACTION para visualizar el menú MENU PRINCIPAL y seleccione "DVD" y presione ENTER.

2 Presione ▲▼◀▶ para seleccionar "CONF. DISCO" y presione ENTER.

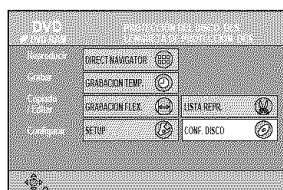

3 Presione ▲▼ para seleccionar "Formateo del disco" y presione ENTER.

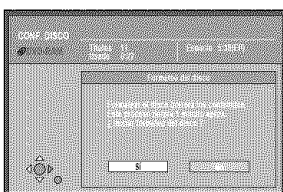

4 Presione ◀▶ para seleccionar "Sí" y presione ENTER.

5 Presione ◀▶ para seleccionar "Iniciar" y presione ENTER.

- Aparecerá un mensaje cuando haya finalizado el formateo.

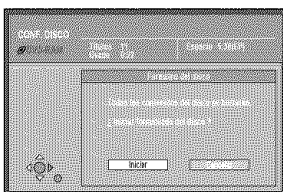

6 Presione ENTER.

■ Para detener el formateo

Presione RETURN.

Notas:

- No apague la unidad ni desconecte el cable de alimentación de CA mientras el mensaje "Formateando el disco" aparezca en el televisor. Si lo hace, es posible que el disco no pueda utilizarse. (Este proceso puede tardar hasta un máximo de 70 minutos (DVD-RAM). Si tarda más de 2 minutos, puede cancelarlo pulsando RETURN. En este caso, el disco deberá formatearse de nuevo).
- Todos los datos del disco se borrarán cuando se formatee, incluyendo grabaciones realizadas con esta unidad. Los datos escritos en el disco mediante un computador también se borrarán.
- Cuando un disco se ha formateado mediante esta unidad, es posible que no sea posible utilizarlo en ningún otro equipo.
- El disco no podrá formatearse si la lengüeta de protección contra escritura está en la posición protegida (PROTECT). Retire la protección para continuar.
- Los DVD-R y los CD-R/RW no pueden formatearse.

Finalizar un disco

DVD-R (Únicamente para DVD-R grabados en esta unidad)

Puede reproducir DVD-R en reproductores DVD compatibles finalizándolos en esta unidad y convirtiéndolos en DVD de vídeo que cumplan con los estándares de DVD de vídeo.

1 Presione ACTION para visualizar la pantalla MENU PRINCIPAL y seleccione "DVD" y presione ENTER.

2 Presione ▲▼◀▶ para seleccionar "CONF. DISCO" y presione ENTER.

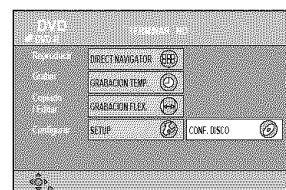

3 Presione ▲▼ para seleccionar "Cerrar" y presione ENTER.

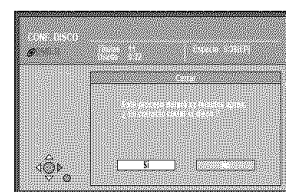

4 Presione ◀▶ para seleccionar "Sí" y presione ENTER.

5 Presione ◀▶ para seleccionar "Iniciar" y presione ENTER.

- La finalización se iniciará.
- Cuando la finalización haya terminado, aparecerá un mensaje.

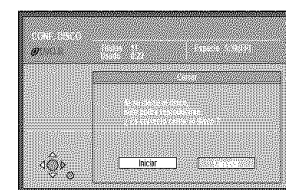

6 Presione ENTER.

Notas:

- No desconecte el cable de alimentación de la CA mientras el mensaje "Finalizando el disco" aparezca en el televisor. Si lo hace, el disco no podrá utilizarse.
- El proceso de finalización puede tardar hasta 15 minutos.
- Sólo podrá finalizar DVD-R que se hayan grabado en esta unidad.
- No podrá grabar en DVD-R que se hayan finalizado.
- Después de la finalización
 - El disco sólo podrá reproducirse y ya no podrá grabar en él ni editarlo.
 - Los DVD-R finalizados en esta unidad no pueden reproducirse en otros reproductores DVD debido a la condición de la grabación.
 - Se producirá una pausa de varios segundos entre los títulos.
 - Los títulos se dividen en capítulos de unos 5 minutos*.
- Este tiempo puede variar en gran medida en función de la condición y el modo de la grabación.
- Visite la página principal de Panasonic para obtener más información acerca de los DVD.

Para EEUU: <http://www.panasonic.com/playDVD-R>

Para Canadá: <http://www.panasonic.ca>

	Antes de la finalización	Después de la finalización
Pantalla del disco en esta unidad	DVD-R	DVD-V
Grabación/edición/introducción de nombres	○	×
Reproducción en otros reproductores DVD	×	○

Es posible que los DVD-R finalizados en esta unidad no puedan leerse en otros reproductores DVD debido a la condición de la grabación.

Grabación

Grabación de un toque (DVD → cinta)

Podrá transferir (grabar) programas grabados en un disco*1 a una cinta con sólo pulsar un botón.

En la grabación de un toque, todos los contenidos de un disco se grabarán automáticamente en una cinta.

*1 Los discos disponibles para transferir (grabar) a una cinta son los DVD-RAM y los DVD-R. La mayoría de DVD de vídeo no pueden copiarse porque están protegidos contra copia.

Preparación

Lado del DVD:

- Introduzca un disco que contenga los programas que desee copiar.

Lado del VHS:

- Introduzca una cinta con la lengüeta de grabación intacta.
- La grabación se realizará desde el principio de la cinta. Compruebe los contenidos de la cinta cuidadosamente, ya que éstos se borrarán completamente.
- Coloque la unidad en el modo Grabación.

- 1 Con el VCR y el DVD en el modo detenido, mantenga presionado el botón VCR← durante unos 3 segundos después de que aparezca el cuadro de diálogo siguiente en la pantalla.

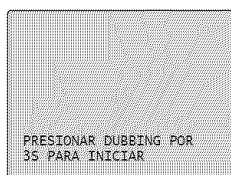

- 2 La grabación se iniciará. La información se mostrará en la pantalla y en la pantalla secundaria.

La grabación se detendrá automáticamente cuando la reproducción del disco finalice o al final de la cinta.

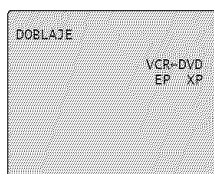

Pantalla secundaria



■ Para detener la grabación

Presione STOP.

- Cuando el lado de la reproducción (del origen) finalice y la unidad se ponga en modo detenido, o bien si la grabación se detiene debido a un error, aparecerá un breve mensaje.

■ Sólo se permiten las siguientes operaciones durante la transferencia (grabación):

- Detener la transferencia (grabación) pulsando STOP.
- Seleccionar un canal pulsando CH ▲ ▼ o las teclas numéricas.
- Seleccionar el modo de entrada pulsando INPUT.
- Encender o apagar la unidad pulsando POWER. (la copia continuará aunque la unidad se apague).
- Cambiar el modo de audio pulsando AUDIO.

Grabación de un toque (cinta → DVD)

RAM DVD-R

Podrá transferir (grabar) programas grabados en una cinta a un disco*1 con sólo pulsar un botón. En la grabación de un toque, todos los programas se transfieren automáticamente desde el lado de reproducción de una cinta a un disco.

*1 Sólo los DVD-RAM y los DVD-R no finalizados pueden utilizarse para transferir (grabar) desde una cinta.

Nota:

- Las cintas de VHS protegidas contra copias no pueden copiarse a un disco.

Preparación

Lado del VCR:

- Introduzca la cinta que contenga el material que desee grabar.

Lado del DVD:

- Cuando utilice un disco de cartucho, compruebe que pueda escribirse.
- Compruebe que haya el espacio suficiente en el disco para contener la grabación.
- Coloque la unidad en el modo de grabación.

- 1 Con el VCR y el DVD en el modo detenido, mantenga presionado el botón →DVD durante unos 3 segundos después de que aparezca el cuadro de diálogo siguiente en la pantalla.

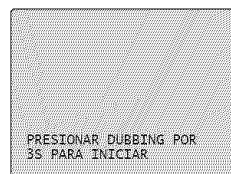

- 2 La copia se iniciará. La información se mostrará en la pantalla y en la pantalla secundaria.

La grabación se detendrá automáticamente cuando la reproducción de la cinta finalice o al final del disco.

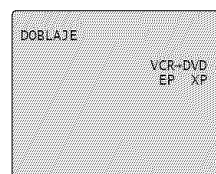

Pantalla secundaria

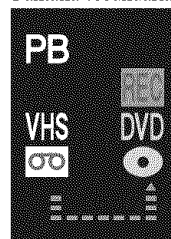

■ Para detener la grabación

Presione STOP.

- Cuando el lado de la reproducción (del origen) finalice y la unidad se detenga, o bien si la grabación se detiene debido a un error, aparecerá un breve mensaje.

■ Sólo se permiten las siguientes operaciones durante la transferencia (grabación)

- Detener la transferencia (grabación) pulsando STOP.
- Seleccionar un canal pulsando CH ▲ ▼ o las teclas numéricas.
- Seleccionar el modo de entrada pulsando INPUT.
- Encender o apagar la unidad pulsando POWER. (la copia continuará aunque la unidad se apague).
- Cambiar el modo de audio pulsando AUDIO.

Index

A	
Accessories	2
AC Power Plug	11
Add or Delete a Channel	17
Audio Adjustment	26
Audio Input Connector 1	11
Audio Input Connector 2	10
Audio Menu	25
Audio Mode for Playback	33
Audio Mode for Recording	29
Audio Mode for TV Viewing	21
Audio Mute	20
Audio Output Connector (L/R)	11
Automatic Channel Setting	16
Automatic Clock Setting	17
Auto Playback	34
Auto Rewind	34
Auto Shut Off	39
B	
Before using Disc Functions	40
Before using VCR Functions	28
Blocking Message	38
Blue Screen Display	39
Built In Speakers	10
C	
Canadian English Language Ratings	37
Canadian English Language Ratings Chart	38
Canadian French Language Ratings	37
Canadian French Language Ratings Chart	38
Cancel a Timer Recording:(Recording is in progress)	31
Caption On Mute Feature	24
Cassette Compartment	10
Change Language Setting	18
Changing audio during play (DVD)	54
While playing DVD-RAM	54
While playing DVD-Video	54
Changing your secret code	35
Channel & Function Display	39
Chapter operations (DVD)	59, 62
Add Chapter	62
Combine Chapters	59, 62
Divide Chapter	59, 62
Erase Chapter	59, 62
Move Chapter	62
Closed Caption Mode Feature	23
Commercial Skip	34
Common procedures	55
Disc menu	55
Play menu	56
Connecting the "1, 2" AV Input Terminals	13
Connecting the Audio Output Terminal	14
Connecting the Headphones / Earphones Jack	13
Connecting the RF in Terminal	12
Create chapters	54
Creating play lists	60
D	
Digital Auto Tracking	34
Disc Setting Procedure	63
Disc Name	63
Disc Protection	63
Finalize	65
Format Disc	64
Select First play	64
Disc Tray	10
Displaying the television image as a picture-in-picture	52
Dubbing	70
DVD-RW	6
DVD Dialog Enhancer	27
DVD Functions Window	41
DVD MPEG-DNR	27
DVD Volume Adjust	19
E	
Editing titles/chapters and playing chapters	57
Eject tape	32
Entering text Procedure	66
Enter Secret Code	35
F	
Fast forward and rewind (Search) (DVD)	51
Finalize	65
Flexible Recording (FR)	45
Forward/Reverse scene search [Tape]	32
Frame-by-frame viewing (DVD)	52
Frame by Frame picture [Tape]	32
Front Display Setting	19
Front View (Sub Display)	11
I	
Important Safeguards and Precautions	4
Index Search	33
Information (Disc)	6
Discs you can use	7
Discs you can use for recording and play	7
Disc Composition Examples	7
Disc Handling	8
MP3	8
Play-only discs	6
Region Management Information	8
To clean disc surface	8
Which should I use, DVD-RAM or DVD-R?	8
Information (Unit, Cassette)	6
DST (Daylight Saving Time)	6
Head Cleaning	6
Loading the Batteries	6
Prevent Accidental Tape Erasure	6
Initial Setup (Ready to Play)	16
Inserting a Disc	40
Inserting a Tape	28
M	
Manual Clock Setting	17
Manual Dubbing	71, 73
Manual Tracking Control	34

O		
ON-TIMER.....	22	
One Touch Dubbing (DVD → Tape).....	70	
One Touch Dubbing (Tape → DVD).....	72	
One Touch Recording (OTR).....	29	
Optical digital audio output connector.....	11	
P		
Pause a Recording.....	29	
Phones Jack.....	10	
Playback Auto Eject.....	34	
Playback a Tape.....	32	
Playing discs procedure.....	50	
Playing play lists (DVD).....	61	
Using play list to edit play list/chapters.....	61	
Playing while you are recording.....	48	
Chasing playback.....	48	
Simultaneous Recording and Play.....	48	
Time Slip (Playing while you are recording).....	48	
Play list operations (DVD).....	62	
Edit → Change Thumbnail.....	62	
Edit → Copy.....	62	
Edit → Create.....	62	
Edit → Enter Name.....	62	
Erase.....	62	
Properties.....	62	
Q		
Quick View.....	52	
R		
Rapid Fast forward tape.....	32	
Rapid Rewind tape.....	32	
Rapid Tune.....	20	
Receivable Broadcast Types.....	21	
Recording and Playing Back a Closed Caption/Text Program.....	24	
Recording from a video cassette recorder.....	49	
Record On a Disc.....	44	
Recording modes and approximate recording times.....	45	
Record On a Tape.....	29	
Remote Control Buttons.....	9	
Remote Sensor.....	10	
Repeat Play.....	32	
Reset all unit Memory Functions.....	18	
Review, Replace or Clear Program Contents : (Recording is not in progress).....	31	
S		
Safety Precaution.....	2	
Safety Precautions.....	3	
Selecting audio to record (DVD).....	45	
Selecting Input Mode.....	20	
Selecting recorded programs (titles) to play.....	51	
Set Up to 16 Programs (DVD).....	46	
Add a program.....	46	
Check, change or delete a program.....	47	
Set Up to 9 Programs.....	30	
Skipping.....	51	
Skipping a minute forward (CM Skip) (DVD).....	51	
Skipping the specified time (Time Slip).....	52	
Sleep Timer.....	22	
Slow-motion playback (DVD).....	52	
Slow Motion picture [Tape].....	32	
Starting from a selected item.....	52	
Starting play from where you stopped it (Resume Function).....	50	
Status messages (Disc).....	41	
Still (Freeze) picture [Tape].....	32	
Stop a Record.....	29	
Stop a Tape.....	32	
Surround Sound System.....	27	
T		
Table of Contents.....	5	
Time Zone Adjust.....	18	
Title operations (DVD).....	58	
Edit → Change Thumbnail.....	59	
Edit → Enter Name.....	58	
Edit → Set up Protection/Cancel Protection.....	58	
Edit → Shorten.....	58	
Erase.....	58	
Properties.....	58	
To erase a program that is being played back.....	53	
To View a Blocked Program/Movie.....	38	
TV/VCR Status & Clock Display.....	39	
U		
Unit's Settings Procedure.....	67	
Language Code List.....	69	
Unit's Settings List.....	68	
Unit Buttons.....	10	
Using menus to play MP3.....	53	
Using the tree screen to find a group.....	53	
Using the tree screen to find a track.....	53	
Using the CH/VOL Button.....	20	
Using the Number and 100 keys.....	20	
US MOVIES Ratings.....	36	
US MOVIES Ratings Chart.....	38	
US TV PROGRAMS Ratings.....	36	
US TV PROGRAMS Ratings Chart.....	38	
V		
V-Lock Control.....	34	
VHF/UHF Antenna Input Terminal.....	11	
Video Adjustment.....	26	
Video Input Connector 1.....	11	
Video Input Connector 2.....	10	
Video Menu.....	25	
W		
Weak Signal Display Feature.....	19	
When a menu screen appears on the television.....	50	
Z		
Zero Search.....	33	

LSQT0840 A

Panasonic Consumer Electronics Company,
Division of Matsushita Electric Corporation of America
One Panasonic Way Secaucus, New Jersey 07094
Panasonic Sales Company ("PSC"),
Division of Matsushita Electric of Puerto Rico, Inc.
Ave. 65 de Infantería, Km. 9.5
San Gabriel Industrial Park, Carolina, Puerto Rico 00985



Printed in Indonesia
LSQT0840 A
S0804-0