

Assembly and Operation

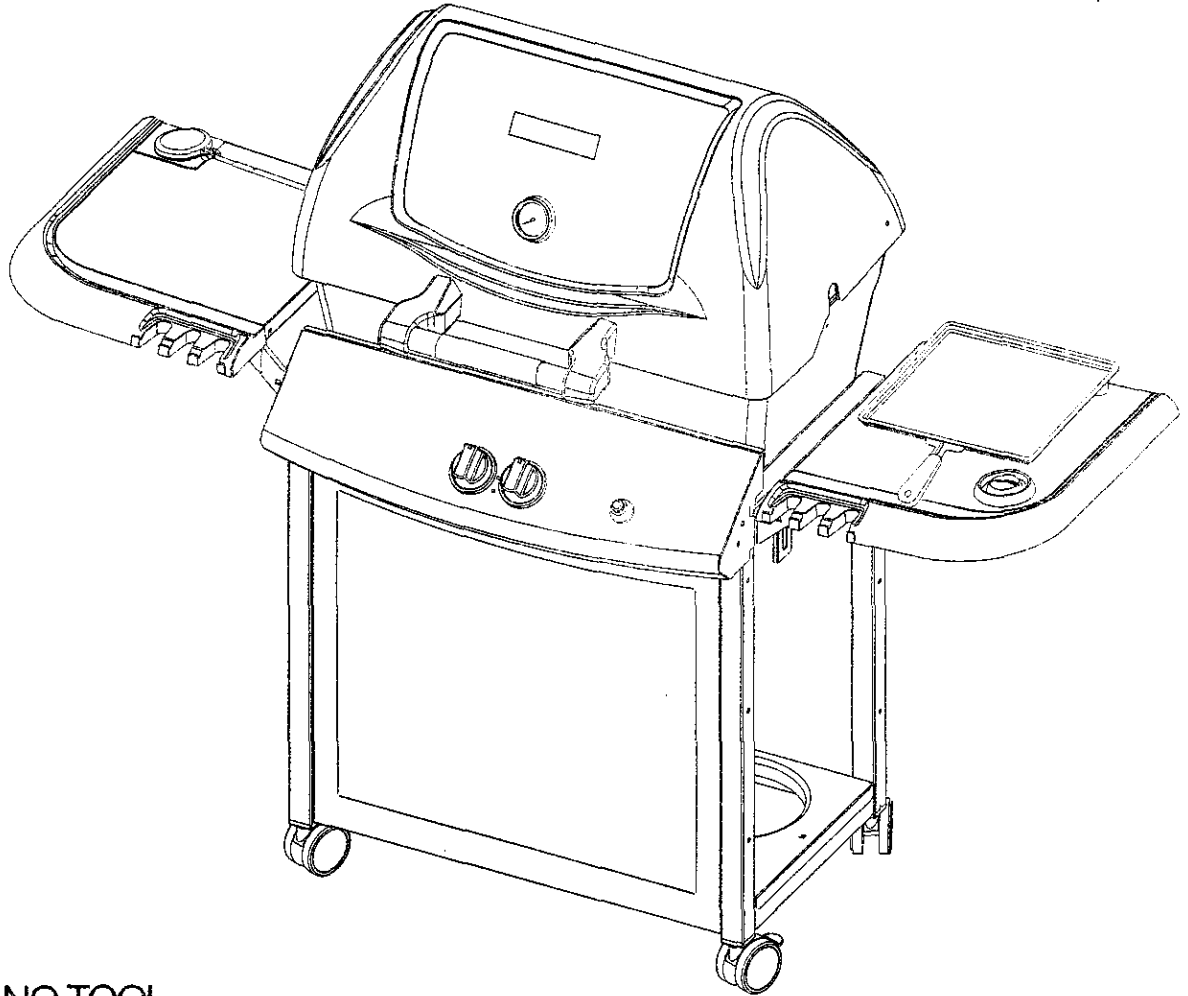

Liquid Propane Gas Grill



NO TOOL
easy
ASSEMBLY

THIS GRILL IS FOR OUTDOOR USE ONLY

CAUTION



Read and follow all Safety Statements, Assembly instructions, and Use and Care Manual Directions before attempting to assemble and cook.

CAUTION



Some parts may contain sharp edges, wear protective gloves if necessary.

WARNING



Failure to follow all manufacturer's instructions could result in serious personal injury and/or property damage.

Customer Service

Toll Free 1-800-396-3838

To Installer/Assembler: Leave these instructions with consumer.

To Consumer: Keep this manual for future reference.

Table of Contents

| | |
|--------------------------------|-------|
| Warranty..... | 1 |
| Safety..... | 1 |
| Caring for your equipment..... | 2-4 |
| Hardware..... | 5 |
| Assembly..... | 6-17 |
| Operation..... | 18-20 |
| Cleaning and Maintenance..... | 21-22 |
| Parts..... | 23 |
| Exploded view..... | 24 |
| Troubleshooting..... | 25 |
| Notes..... | 26 |

Product Record

IMPORTANT: Fill out the product record information below.

Model Number _____

UPC (on carton) Label Lot # GG _____

Serial Number _____

Date Purchased _____

Limited Warranty

One Year Full Warranty on Kenmore Grill

For one year from the date of purchase Sears will repair or replace, at our option, any grill part (except for paint finish) that is defective in material or workmanship. If this grill is defective in material or workmanship within one year from the date of purchase, contact Sears at 1-800-4-MY-HOME®.

Additional Warranty on Specific Grill Parts

For the time periods listed below, Sears will replace the following specific grill parts free of charge if they are defective in material or workmanship (Part replacement only, labor not included) :

Lifetime on Cast Aluminum Lids and Bottoms

Five years from purchase date on Stainless Burners

All warranty coverage excludes ignitor batteries and any grill part paint loss or rusting which are either expendable parts that can wear out from normal use in less than a year, or are conditions that can be the result of normal use, accident or improper maintenance.

All warranty coverage is void if this grill is used for commercial or rental purposes.

This warranty gives you specific legal rights, and you may also have other rights which vary from state to state.

Sears, Roebuck and Co., Dept. 817WA, Hoffman Estates, IL 60179

WARNING



Combustion byproducts produced when using this product contain chemicals known to the State of California to cause cancer, birth defects, or other reproductive harm.

SAFETY INSTRUCTIONS

WARNING



IF YOU SMELL GAS:

1. Shut off gas supply to the appliance.
2. Extinguish any open flame.
3. Open lid.
4. If odor continues, immediately call your gas supplier or your fire department.

WARNING



- Do not store or use gasoline or other flammable vapors and liquids in the vicinity of this or any other appliance.
- An LP cylinder not connected for use shall not be stored in the vicinity of this or any other appliance.

CAUTION  For residential use only. Do not use for commercial cooking.

WARNING  **CARBON MONOXIDE HAZARD**
Combustion byproducts include carbon monoxide which has no odor and can cause serious injury or death. Never use inside homes, vehicles or tents.

Call Grill Service Center For Help And Parts
If you have questions or need assistance during assembly, please call 1-800-396-3838. You will be speaking to a representative of the grill manufacturer and not a Sears employee. To order new parts call Sears at 1-800-4-MY-HOME®.

GETTING FAMILIAR WITH YOUR GRILL

WARNING  Do not use your grill until you have read and understood all the information in this manual. It is extremely important to be sure that:

- Your grill is properly assembled.
- There are no leaks in the gas supply system (see 'Leak Testing' section).
- The burner is properly assembled with the venturi tubes seated over the valve outlets (Figure 1 below) and there are no blockages present in the venturi tubes (see 'Cleaning Venturi Tubes' section).
- Electrical supply cords and/or gas supply hoses are kept away from any heated surfaces.
- Your grill is positioned in a safe location (see 'Installation' section).

Figure 1.

- Ensure valve outlets (orifices) are assembled 3/8" (1 cm) into the venturi tubes.
- Check to see that the valve outlets and venturi tubes are parallel to the bottom of the base casting of your appliance.

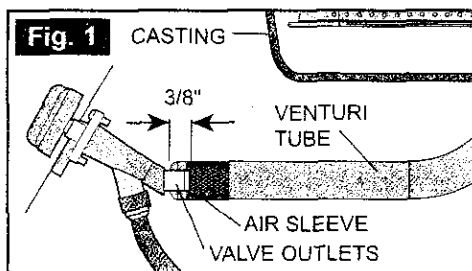

WARNING  Failure to ensure correct venturi tube assembly may result in a hazardous fire or explosion causing serious bodily injury and/or property damage.

CARING FOR YOUR EQUIPMENT INSTALLATION

THE INSTALLATION OF THIS APPLIANCE MUST CONFORM WITH LOCAL CODES OR, IN THE ABSENCE OF LOCAL CODES:

- In Canada: must conform to CAN/CGA - B149.2 Propane Installation Code or CAN/CGA B149.1 Natural Gas Installation.
- In the U.S.A.: must conform to National Fuel Gas Code ANSI Z223.1.

WARNING  When deciding where to place your appliance, follow these minimum clearance distances to adjacent combustible materials:

- 24 inches (61 cm) from side of unit (See Figure 2)
- 18 inches (46 cm) from back of unit (See Figure 2)

FOR YOUR OWN SAFETY:

- Only use your grill OUTDOORS in a well ventilated area -- preferably 10 feet (3m) from your residence or any outbuildings.
- Always keep the area around your grill clear of any combustible materials, gasoline, or other flammable liquids.
- **DO NOT** operate this grill under overhead or unprotected construction.
- **DO NOT** obstruct the flow of combustion and ventilation air to the grill.
- **DO NOT** use in garages, sheds, breezeways, or other enclosed areas.
- **DO NOT** store a spare L.P. (propane) cylinder under or near your grill.
- **DO NOT** leave your grill unattended while in operation.
- **DO NOT** allow children to operate or play near your grill.
- **DO NOT** use while under the influence of alcohol or drugs.
- **DO NOT** install/use in or on recreational vehicles and/or boats

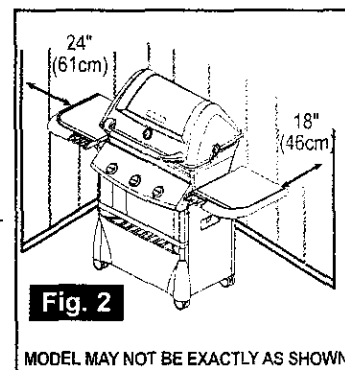

ELECTRICAL CAUTION

- If any accessory installed on this grill requires an external electrical power source, it must be electrically grounded in accordance with local laws or in the absence of local laws, with the Canadian Electrical Code CSA C22.1 or in the U.S., with the National Electrical Code ANSI-NFPA 70.
- The three-prong plug provides protection against shock hazard and should be plugged directly into a properly grounded three-prong receptacle. Do not cut or remove the grounding prong from this plug.
- Ensure all electrical supply cords and fuel supply hoses are kept well away from any heated surfaces.

L.P. GAS CYLINDER

Gas cylinders manufactured today have mechanisms to provide worry free grilling year round:

Q.C.C.1 or Type 1-Quick Connect Coupling Valve,

ensure fast tank hook-ups requiring only hand tightening. The redundant valve system inhibits the flow of gas to the burner if the connection is not correct.

O.P.D. or Overfill Protection Device

prevents accidental gas leaks caused by cylinder 'over-pressurization', the leading cause of cylinder gas leaks. The float in the tank will automatically stop filling at 80% capacity, leaving a 20% area for the expansion of liquid. Without this safety feature, the relief valve may open and discharge propane, creating a potential safety hazard. An O.P.D. cylinder is easily distinguished by its triangular hand wheel valve. (Figure 3)

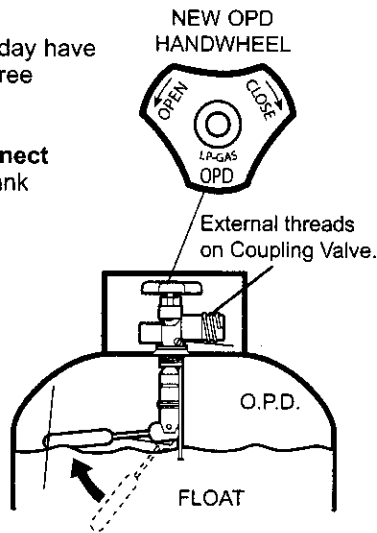

Fig. 3

FILLING STOPS AT 80%

1. SPECIFICATIONS

Self-contained propane gas grill systems are designed to be used only with a 20 lb (9.1 kg) propane cylinder, equipped with a Type 1 cylinder valve and incorporating an overfill protection device (O.P.D.). **THE CYLINDER SHOULD NOT EXCEED 18 1/2" (472 MM) IN HEIGHT AND 12 1/2" (317 MM) IN DIAMETER.** This grill cannot be connected to a #510 P.O.L type valve (ones with left-hand threads).

The cylinder for your gas grill must be constructed and marked in accordance with the specifications of L.P. gas cylinders:

In Canada: The National Standards of Canada CAN/CSA-B339, Cylinders, Spheres and Tubes for Transportation of Dangerous Goods; and Commission.

In the U.S.: U.S. Department of Transportation (D.O.T.)

DO NOT CONNECT TO A PROPANE GAS CYLINDER EXCEEDING THIS CAPACITY, OR USE A CYLINDER WITH ANY OTHER TYPE OF VALVE CONNECTION DEVICE.

The Type 1 valve is recognizable by the large external thread on the outlet part of the valve. Non Type 1 valves do not have these exterior threads. Any attempt to connect a regulator, with other than the:

- i) Mating Type 1 connector (recognized by the large black coupling nut)

or

- ii) Standard #510 P.O.L. fitting, by use of adapters or any other means.

Could result in damage, fire or injury and may negate the important safety features designed into the Type 1 system. The connection of a #510 P.O.L. fitting will not provide the flow control or temperature shut-off features built into the complete Type 1 System.

THE CYLINDER MUST ALSO BE EQUIPPED WITH:

- a. A shut-off valve terminating in a proper cylinder valve outlet specified in current standards:
 - Canada: CAN/CGA - 1.6a - M98 - Outdoor Gas Grills - Amend. 1.
 - U.S.: ANSI Z 21.58a-1998 OUTDOOR COOKING APPLIANCES.
- b. A listed overfilling protection device (O.P.D.).
- c. A safety relief valve having direct communication with the vapor space of the cylinder.
- d. A collar to protect the tank shut off valve.
- e. An arrangement for vapor withdrawal.
- f. A bottom ring for mounting.

SAFETY:

- Always turn off the cylinder valve tightly when your grill is not in use.
- Handle tank valves with care.
- Never connect an unregulated L.P. gas cylinder to your grill.
- Never store a spare cylinder under or near your grill when in use.
- Never subject any cylinder to excessive heat or direct sunlight.
- Always keep your in-use cylinder securely fastened in an upright position.
- Do not insert any foreign objects into the valve outlet. You may damage the back-check. A damaged back-check can be the source of a leak. Leaking propane may result in explosion, fire, severe personal injury or death.
- **DO NOT** fill the cylinder beyond 80% full.

| | |
|--------------------|-------------------------------------------------------------------------------------------------------|
| WARNING | If the above instructions are not followed exactly, a fire causing death or serious injury may occur. |
|--------------------|-------------------------------------------------------------------------------------------------------|

2. TRANSPORTATION AND STORAGE:

WARNING: Although it is safe when used properly, careless handling of the propane gas cylinder could result in fire, explosion, and/or serious injury.

PROPANE GAS IS HEAVIER THAN AIR, AND WILL COLLECT IN LOW AREAS, INCREASING THE ABOVE RISKS THEREFORE:

- ALWAYS use the cylinder cap provided with your cylinder whenever the cylinder is not connected to your grill. (Figure 4)
- **DO NOT** store in a building, garage or any other enclosed area. Store in a well-ventilated area.
- **DO NOT** store near any gas burning apparatus or in any high-heat areas such as a closed car or trunk.
- Transport and store the cylinder in an upright position -- do not tip on its side.
- Store out of reach of children.
- **DO NOT** smoke while transporting a cylinder in your vehicle.

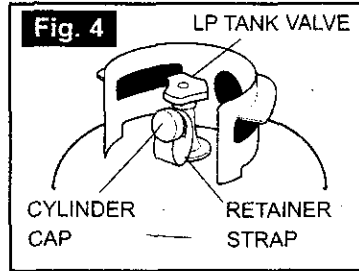

FILLING:

FOR SAFETY REASONS, IF AN OPTIONAL L.P. GAS CYLINDER WAS SUPPLIED WITH YOUR GRILL, IT HAS BEEN SHIPPED EMPTY. THE CYLINDER MUST BE PURGED OF AIR AND FILLED PRIOR TO USING ON YOUR GRILL.

WHEN GETTING YOUR CYLINDER FILLED:

- Allow only a qualified L.P. gas dealer to fill or repair your cylinder.
- **DO NOT** allow the cylinder to be filled beyond 80% full.
- Make sure the L.P. gas dealer checks the cylinder for leaks after filling.

WARNING If the above instructions are not followed exactly, a fire causing death or serious injury may occur.

HOSE & REGULATOR

PROPANE GAS MODELS:

Your grill is designed to operate on L.P. (propane) gas at a pressure regulated at 11" water column (2.74 kPa). A regulator preset to this pressure is supplied with the grill and **MUST** be used.

This regulator is equipped with the Q.C.C. Type 1, quick connect coupling system, which incorporates the following safety features: (Figure 5)

- It will not allow gas to flow until a positive seal has been made. (Figure 6)
- It has a thermal element that will shut off the flow of gas between 240 and 300°F (115 and 150°C).
- It also has a flow-limiting device which, when activated, will restrict the flow of gas to 10 cubic feet per hour (0.28 cubic meters per hour).

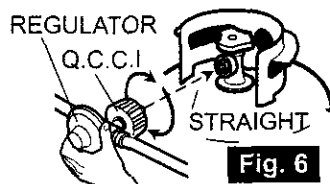
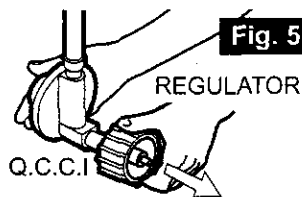

Prior to attaching the propane cylinder to the hose and regulator, be sure the cylinder valve and the appliance valves are OFF. The cylinder valve is turned off by rotating the handwheel (see Figure 3) clockwise (left to right) until it stops and all appliance valves should be in the off position. When attaching the regulator to the cylinder, make sure that the small probe in the nipple is centered in the mating Q.C.C. 1 cylinder valve (see Figure 6). Turn the right hand threaded Q.C.C.1 black nut onto the valve in a clockwise motion until there is a positive stop. **DO NOT USE A WRENCH, HAND TIGHTEN ONLY.**

Should the large black thermally sensitive coupling nut be exposed to temperatures above 240 and 300°F, it will soften and allow the regulator probe to disengage from the cylinder valve -- thereby shutting off the flow of gas. Should this occur, do not attempt to reconnect the nut. Remove the entire regulator assembly, and replace it with a new one. (See 'REPLACEMENT PARTS' section in assembly instructions or contact us at 1-800-396-3838)

The cause of the excessive heat should be determined and corrected before operating your grill again. The regulator probe also contains a flow-sensing element, which will limit the flow of gas to the regulator to a manageable amount (10 cubic feet per hour) in the event of a hose or regulator rupture. If it is evident that the flow control device has been activated, the cause of the excessive flow should be determined and corrected before using your grill again.

Please refer to the troubleshooting guide on page 29 or contact us 1-800-396-3838.

NOTE: IMPROPER LIGHTING PROCEDURES CAN CAUSE THE FLOW CONTROL TO ACTIVATE, RESULTING IN REDUCED HEAT OUTPUT. IF THIS IS SUSPECTED, RESET THE FLOW CONTROL BY SHUTTING OFF ALL BURNER CONTROLS AND THE CYLINDER VALVE. WAIT 30 SECONDS, THEN TURN THE CYLINDER VALVE ON EXTREMELY SLOWLY - WAIT 5 SECONDS AND TURN THE BURNER VALVE ON AND LIGHT AS NORMAL.

- Never connect a propane gas grill to an unregulated propane gas supply or **any other gas**. Do not attempt to alter the hose or regulator in any way.
- The connection fitting must be protected when disconnected from the propane tank. If the fitting is allowed to drag on the ground, nicks and scratches could occur resulting in a leak when connected to the propane tank.

PROPANE AND NATURAL GAS MODELS:

- Do not allow any grease (or other hot material) to fall onto the hose, or allow the hose to come in contact with any hot surfaces of the grill.
- Visually inspect the entire length of the hose assembly before each use of the grill. If it is evident there is excessive abrasion/wear, or the hose is cut, it must be replaced prior to using your grill. Only the hose assembly as specified in the Parts List should be used.
- Follow the 'LEAK TEST' instructions before lighting your grill for the first time, every time a propane cylinder is refilled, if any gas component is changed, if the regulator flow-limiting device has been activated, after prolonged periods of storage or non-use or at least once per season.

HARDWARE

Master Backpack

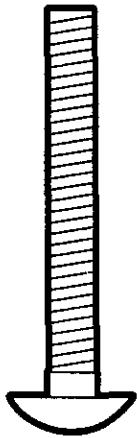

1/4" - 20 X 2" Carriage Bolt
(2 pieces)

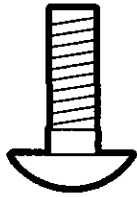

1/4" - 20 X 1/2" Carriage Bolt
(16 pieces)

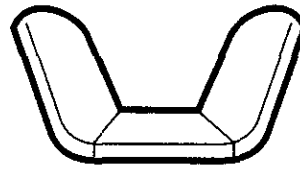

1/4"-20 Large Body Wing Nut
(2 pieces)

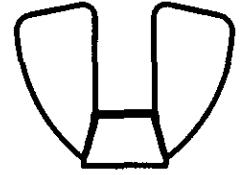

1/4"-20 Tapered Wingnut
(22 pieces)

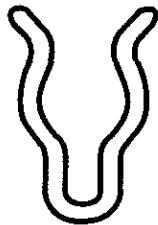

Hinge Clip
(Lid)
(1 piece)

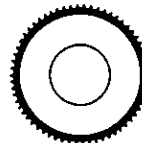

3/8"-16 Knurl Nut
(logo, Heat Indicator)
(2 pieces)



#10-24 Knurl Screw
(Console)
(2 pieces)

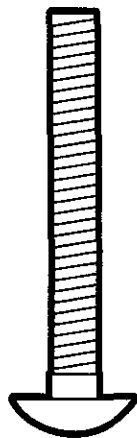

1/4" - 20 X 2" Phillips
(4 pieces)

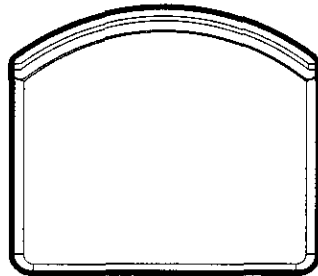

Upper Tank Bracket
(Tank)
(1 piece)

Handle



#10-24 Wing Nut
(Handle)
(2 pieces)

ASSEMBLY

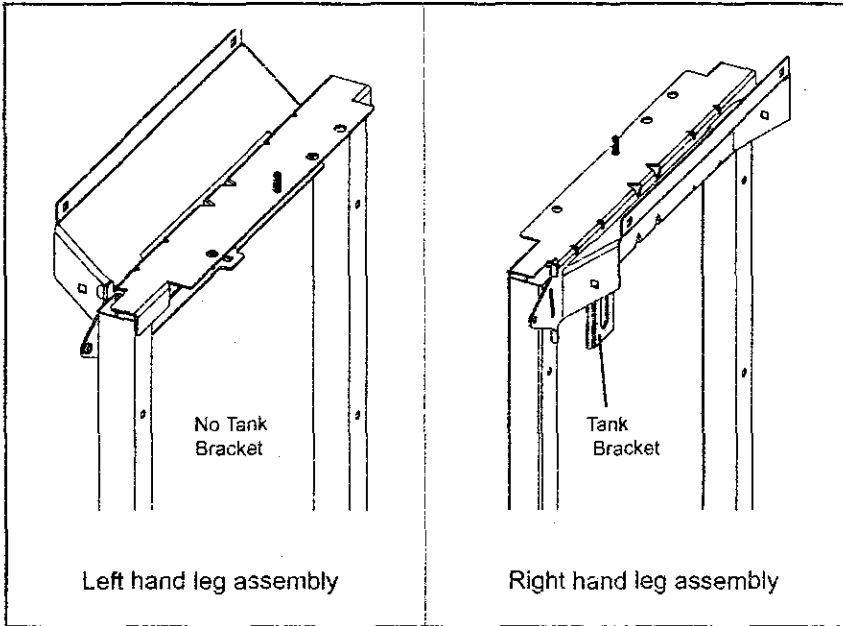

1. Turn leg assembly upside down as shown and insert caster plug. Make sure caster plug tab is in line with notch in leg.

2. Turn leg assembly over and tap on a hard surface until the caster plugs are fully seated.

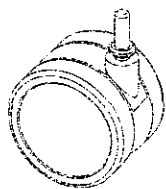
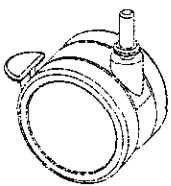
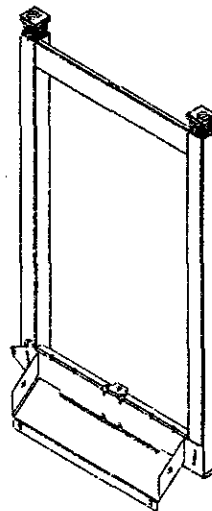

3. Insert locking casters into the caster plugs on front of leg assemblies and press in until caster is fully seated as shown.

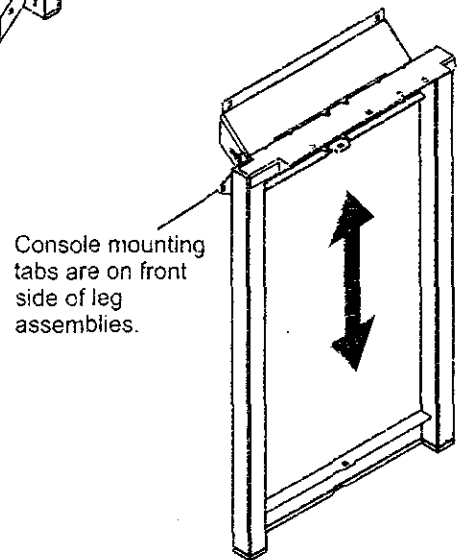
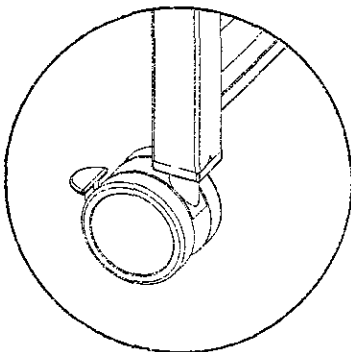

4. Insert non-locking casters into the caster plugs on rear of leg assemblies.

5. Position left hand leg assembly as shown with console mounting tab facing up. Place non-tank side of bottom pan over bottom support. Attach bottom pan with 1/4"-20 x 3/4" carriage bolt and tapered wing nut.

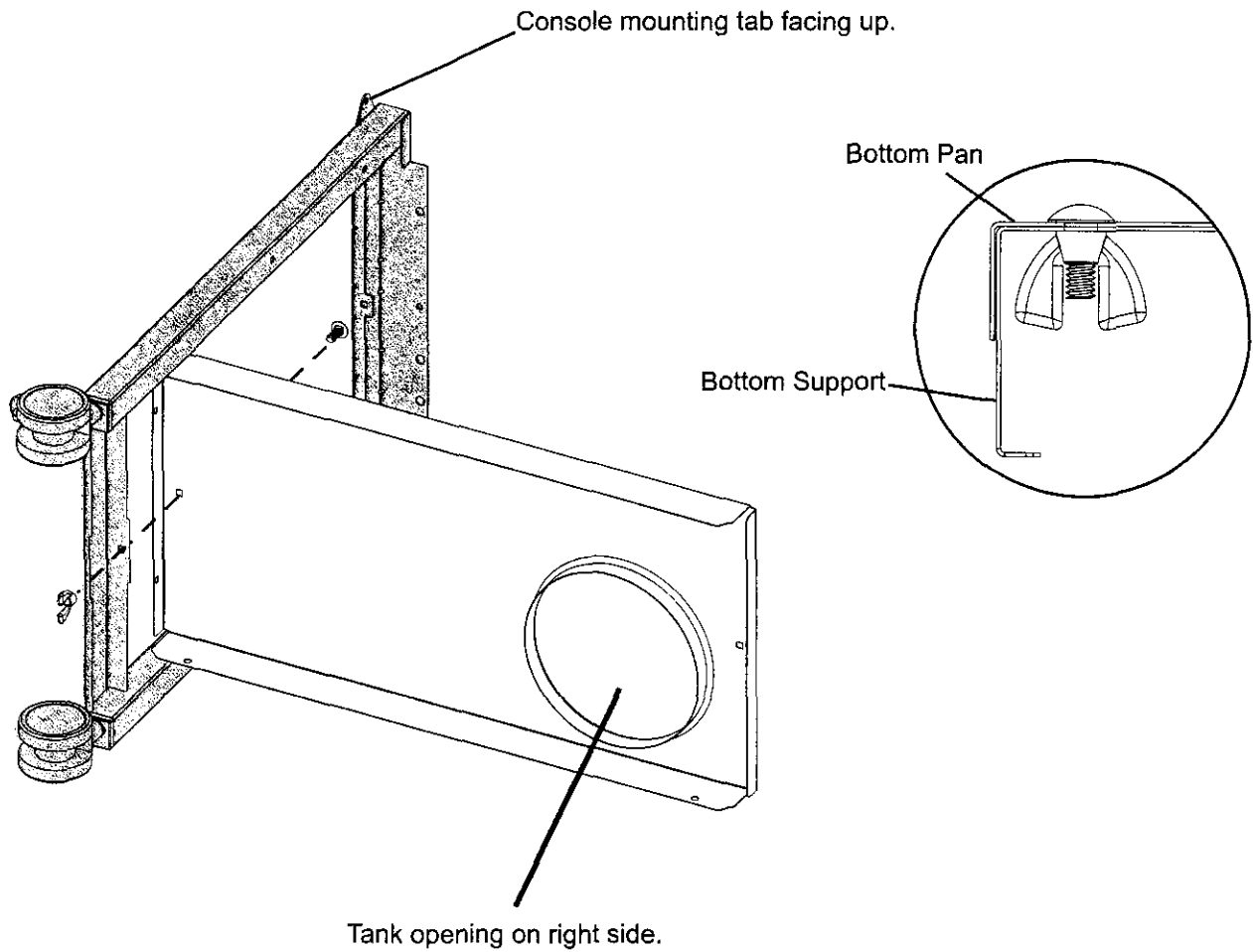

6. Position right hand leg assembly as shown, with console mounting tab facing up. Place tank side of bottom pan over bottom support. Attach bottom pan with 1/4"-20 x 3/4" carriage bolt and tapered wing nut.

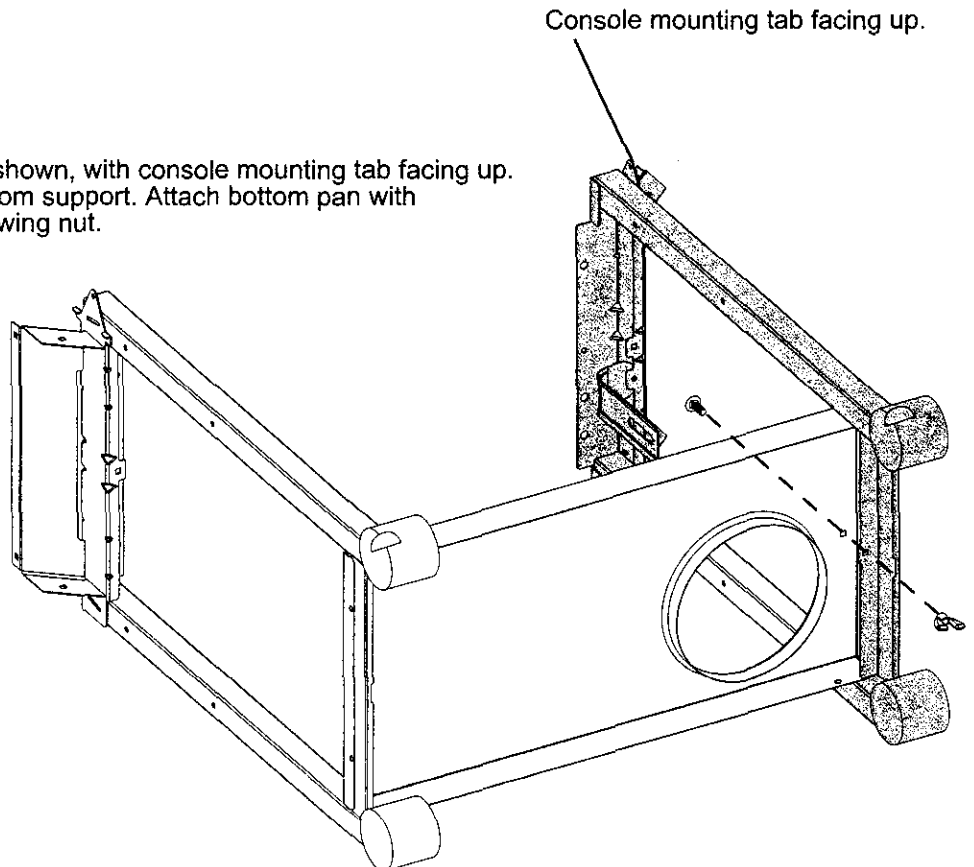
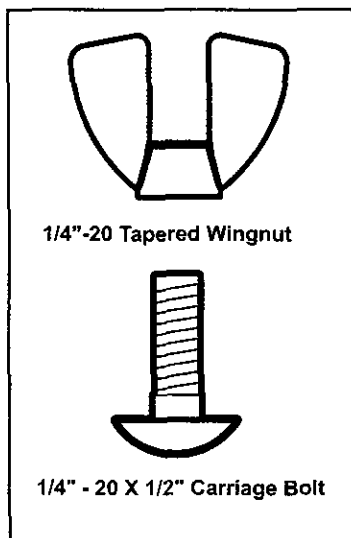

7. Attach console/valve assembly by positioning console over tabs and inserting two #10 knurl screws.

Locate Console on tabs as shown.
(Right side shown)

Mounting Hole

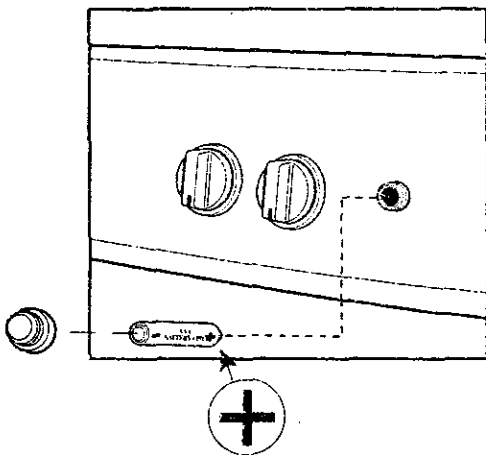
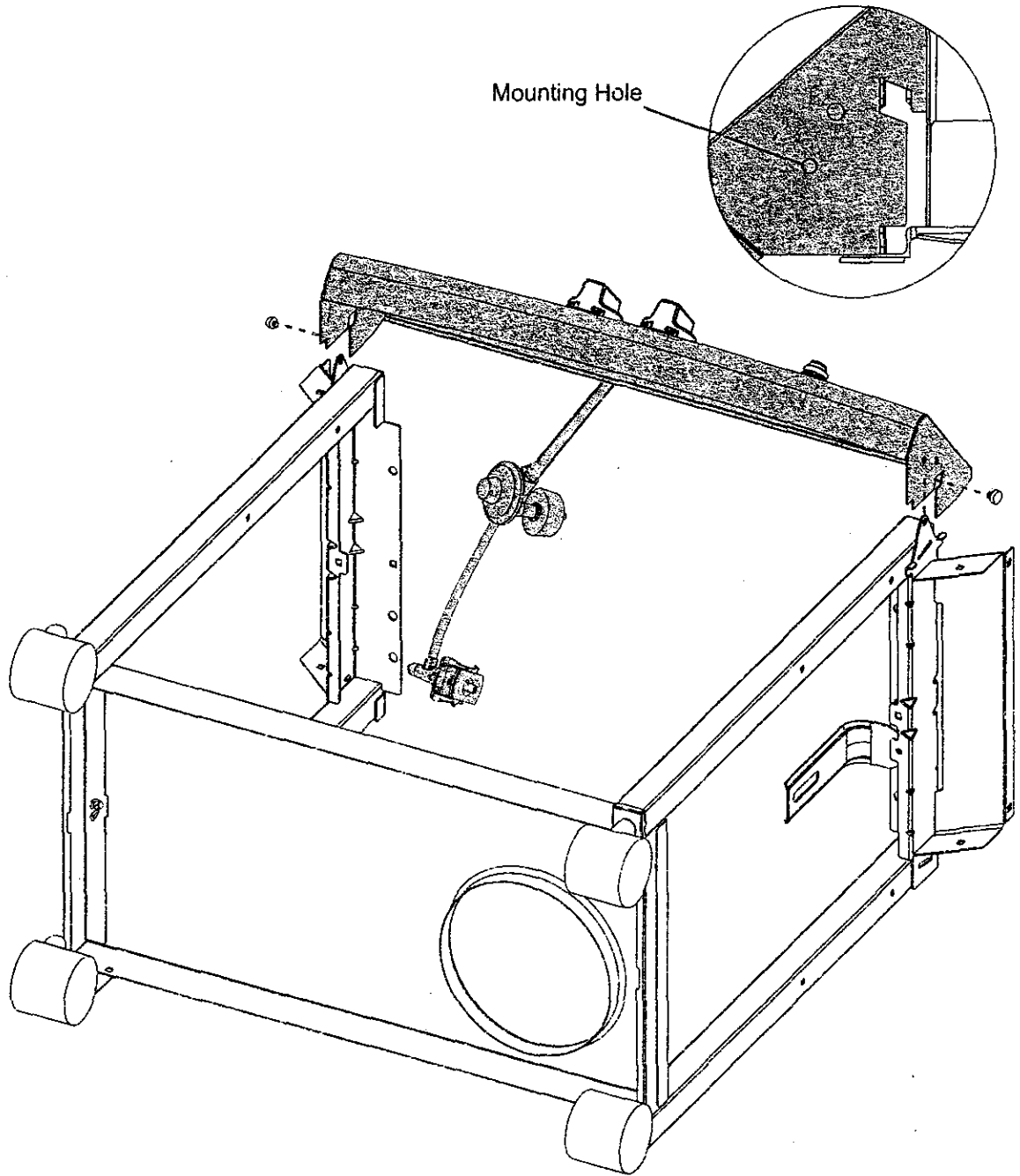

Locate battery in the electronic ignitor bag pack.

Install Battery and Ignitor Button as shown.

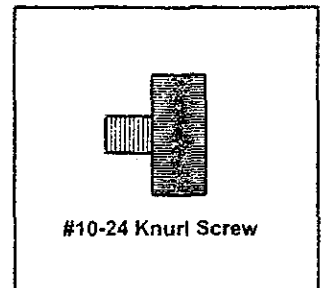

#10-24 Knurl Screw

8. Position front panel into place.
Insert 1/4"-20 x 2" carriage bolt through
the four locations shown.

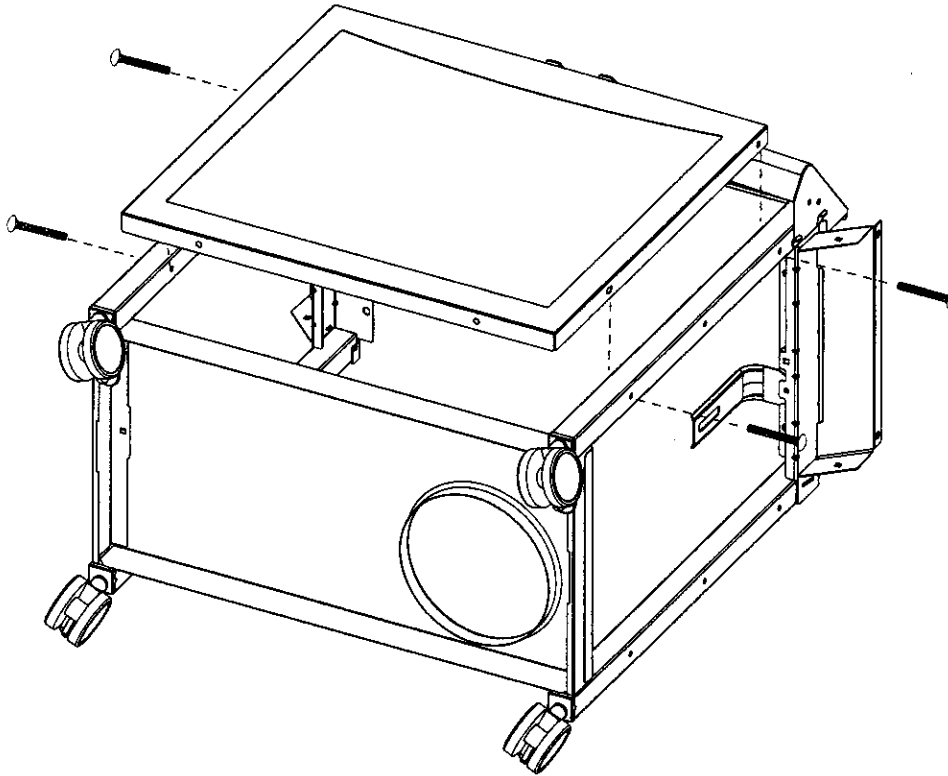

9. Stand the unit onto the casters and attach 4
1/4-20 tapered wing nuts to the four carriage bolts
previously installed. Then align back support with **top**
rear holes and insert (2) 1/4"-20 x 2" carriage bolts and
fasten with (2) 1/4"-20 wingnuts.

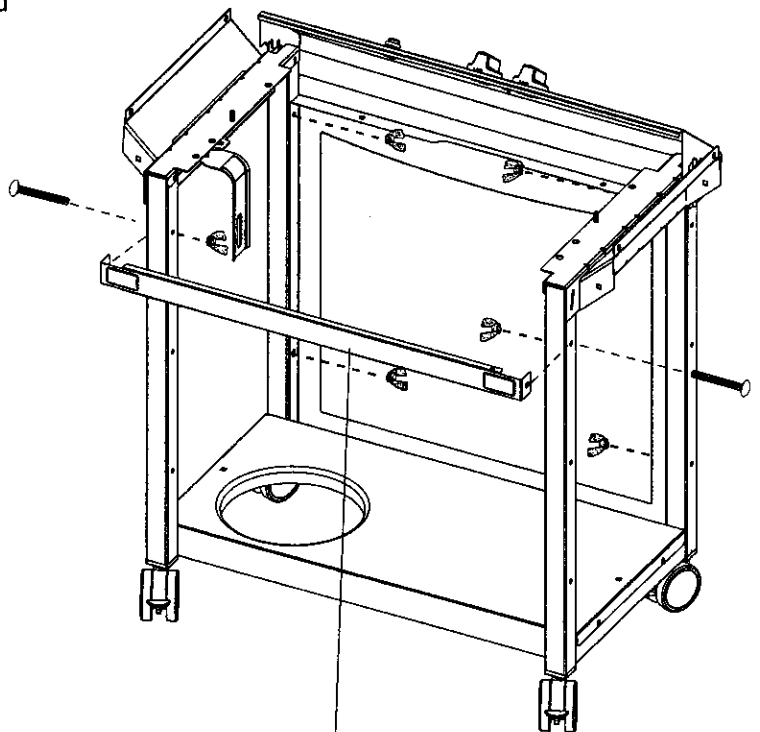

Back Support

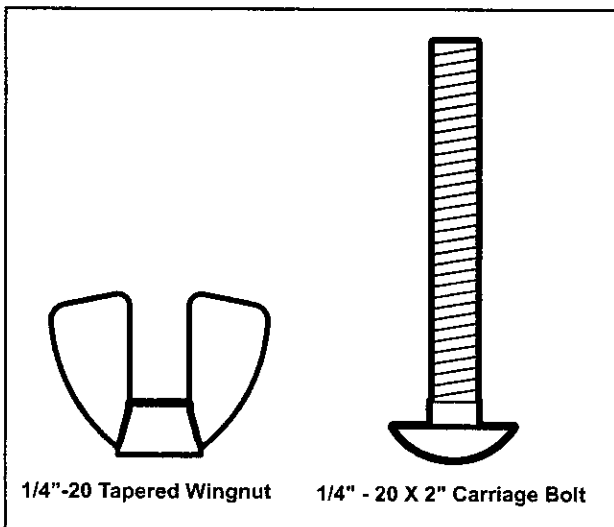

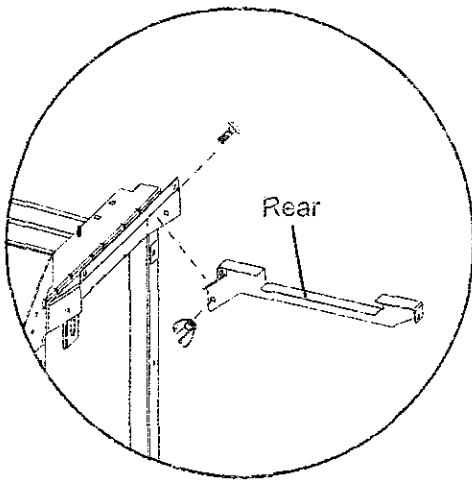

Shelf Brackets fit "inside" mounting bracket.

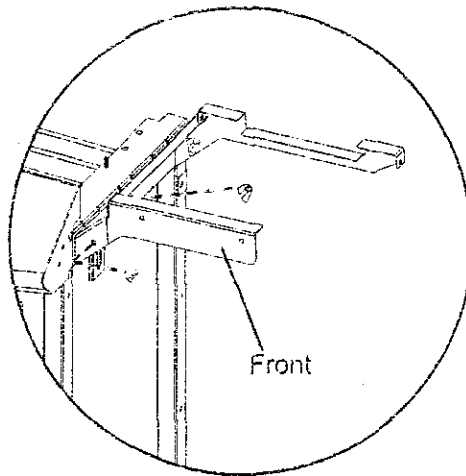

Attach Shelf Brackets with (2) 1/4-20 x 1/2" carriage bolts and (2) tapered wing nuts.

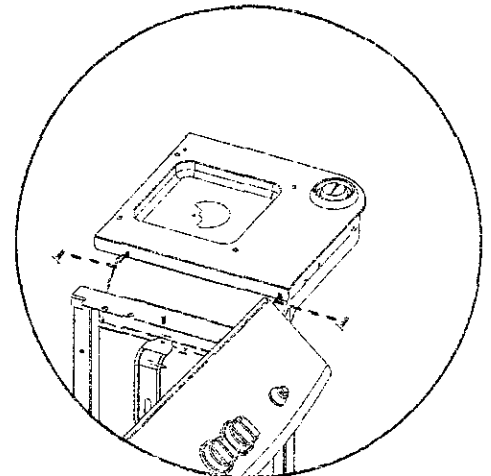

Attach Burner Base with (2) 1/4-20 x 1/2" carriage bolts and (2) tapered wing nuts.

NOTE: Flange on Burner Base "hooks" over flange on mounting bracket.

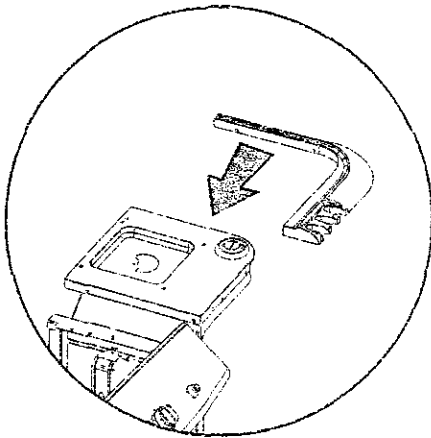

Attach Shelf Trim by, First sliding plastic tab on shelf trim into slot on burner base as shown. Then fix trim to burner base with (3) 1/4-20 x 1/2" carriage bolts and (3) tapered wing nuts.

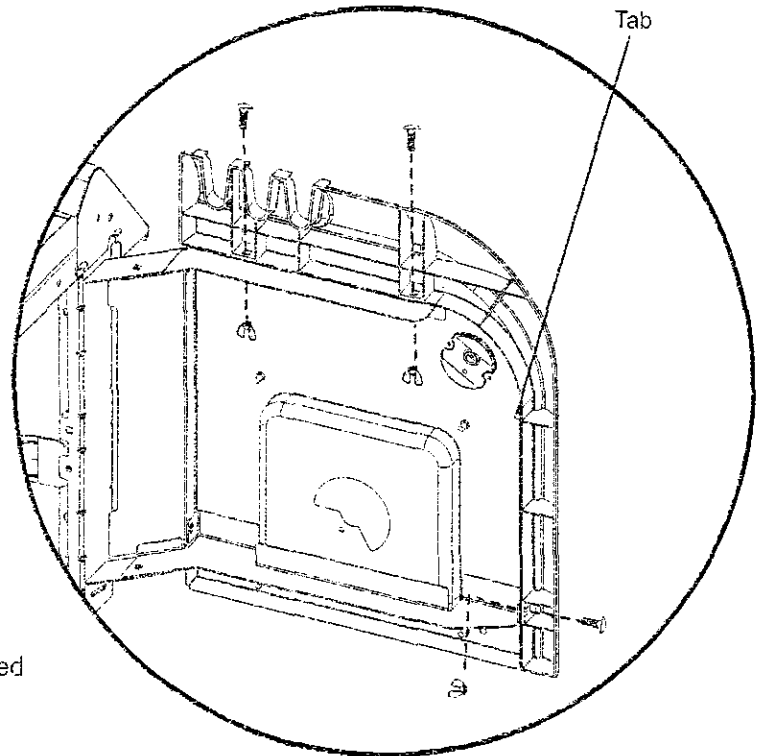

10. Repeat assembly and attachment procedure described for left hand shelf assembly.

IMPORTANT: Mounting bracket flange is "sandwiched" between burner base and shelf brackets.

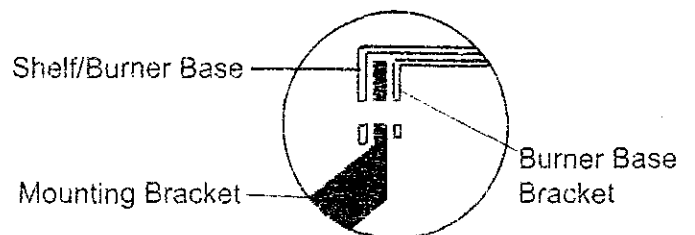
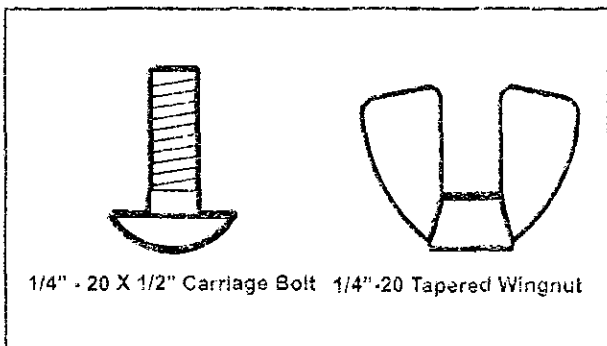

11. Feed side burner valve between RH leg assembly. Insert valve into opening in burner base from underneath (1) and twist in the direction shown (2) so that slots align with rims of shelf plate. Valve orifice should point towards burner. Install knob.

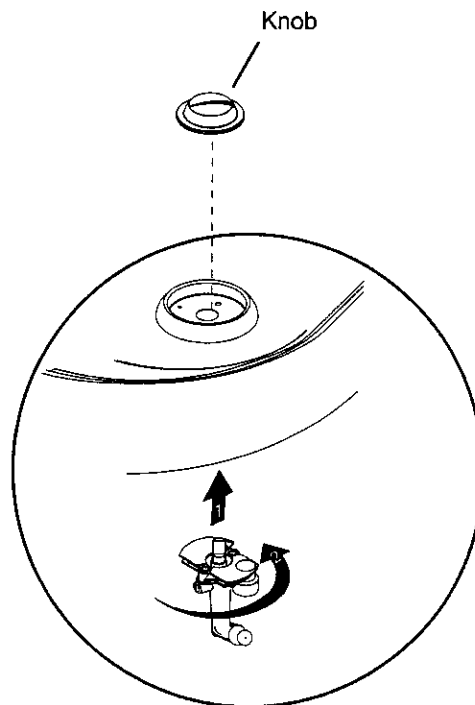
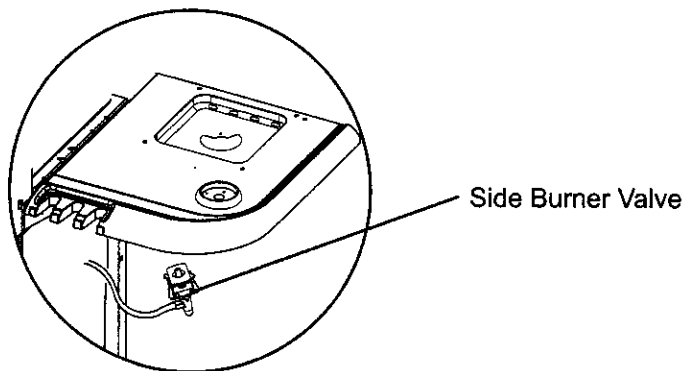

12. Insert burner into Shelf assembly, placing the burner tube over the valve orifice as shown. Place green ground wire eyelet onto burner stud and secure with #10 wingnut.

Place side burner cooking grid into holes as shown.

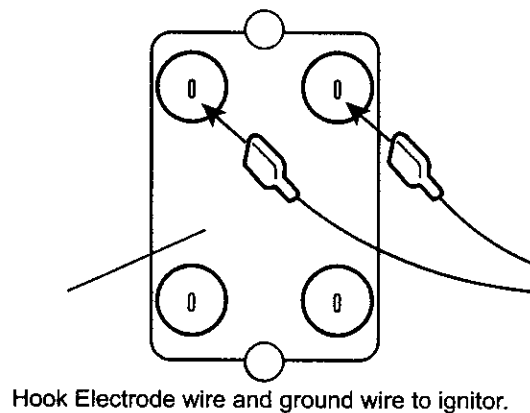
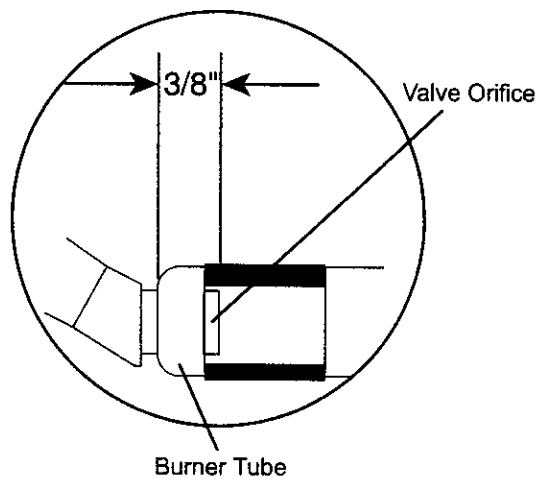
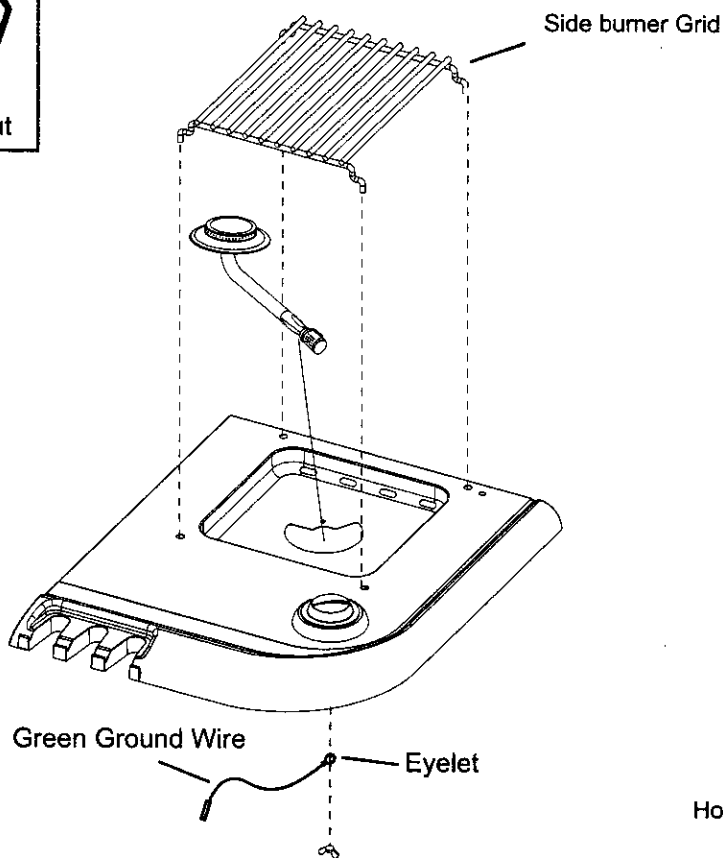

16. Position base casting down over 1/4"-20 studs and secure in place with two 1/4"-20 large body wing nuts.

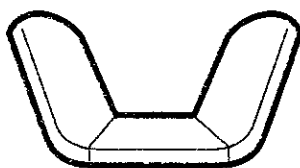
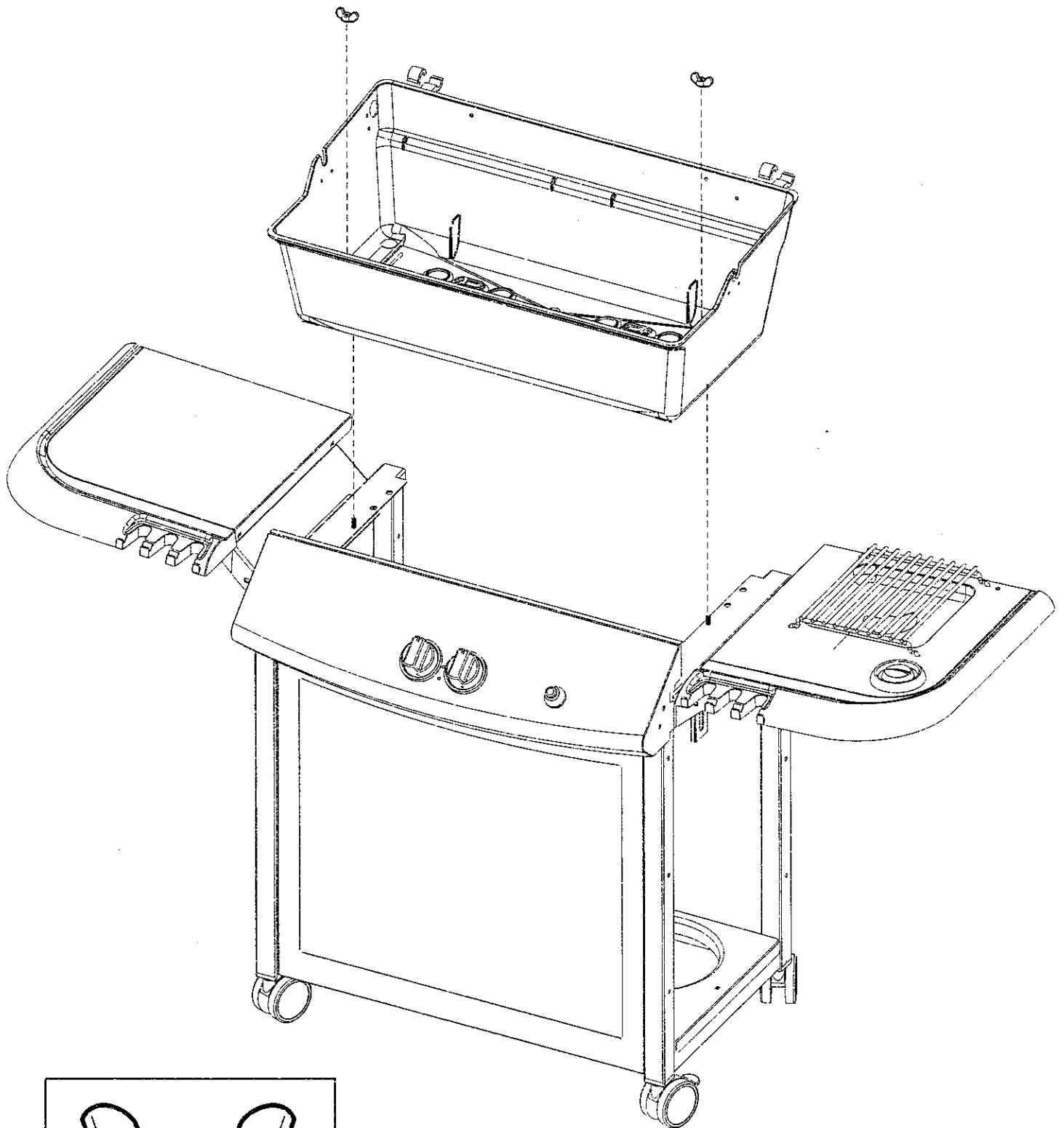

1/4"-20 Large Body Wing Nut

14. Install burner by feeding burner through slots in the base casting and guiding burner tube over orifice in valve, see illustration below. Secure burner by pressing hooks on bottom of burner into slots provided in casting.

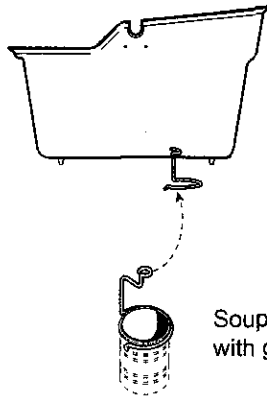

Soup can not supplied with grill.

Secure grease cup clip into slot as shown.

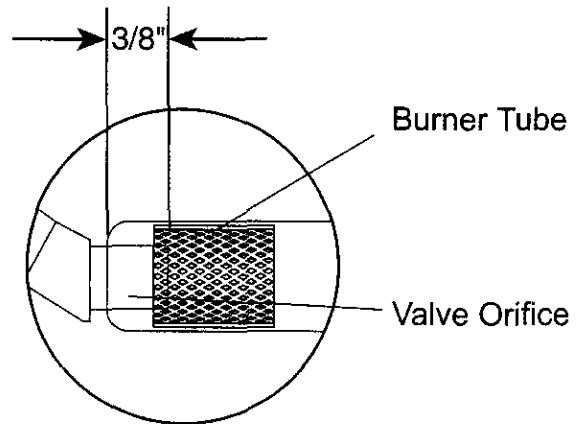

Burner tube must fit over valve orifice as shown.

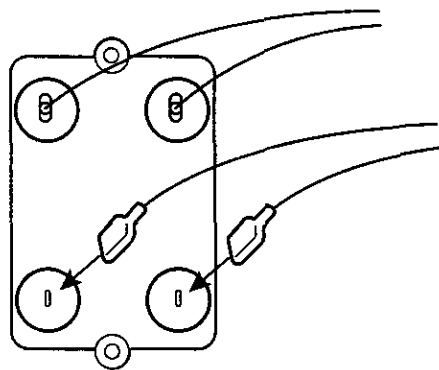
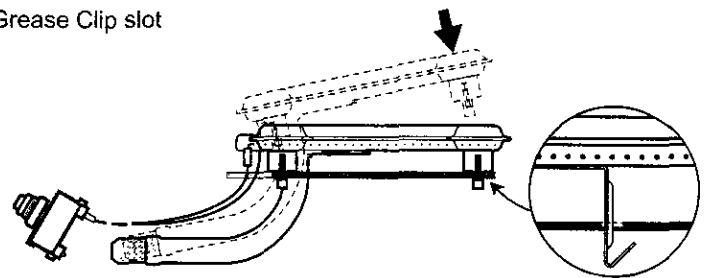
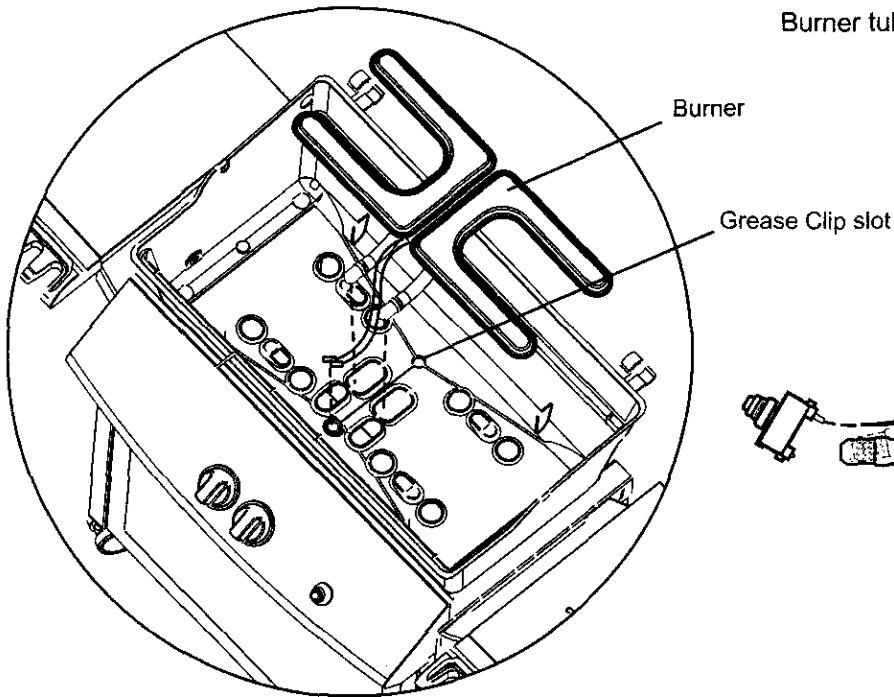

Attach wires from Burner to remaining terminals on ignitor.

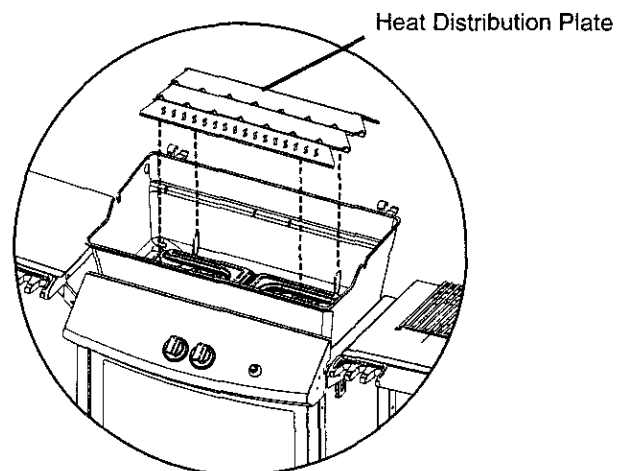

Install Heat Distribution Plate as shown.

15. Install Lid, Handle, Cooking Grids, Warming Rack, Hinge Clip, Logo and Temperature gauge.

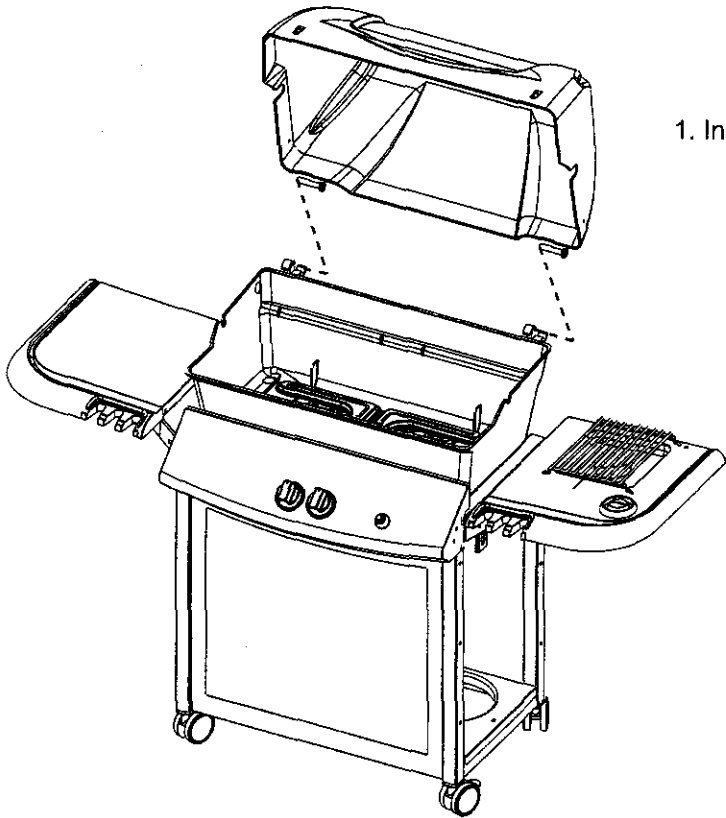

1. Install lid and hinge clip as shown.

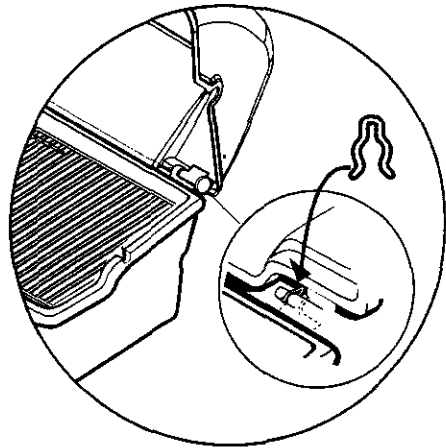

Place handle ends into handle tube as shown

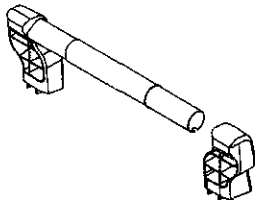

Note: Notches in handle tube mate with tab inside handle cap as shown

Warming Rack

Cooking Grids

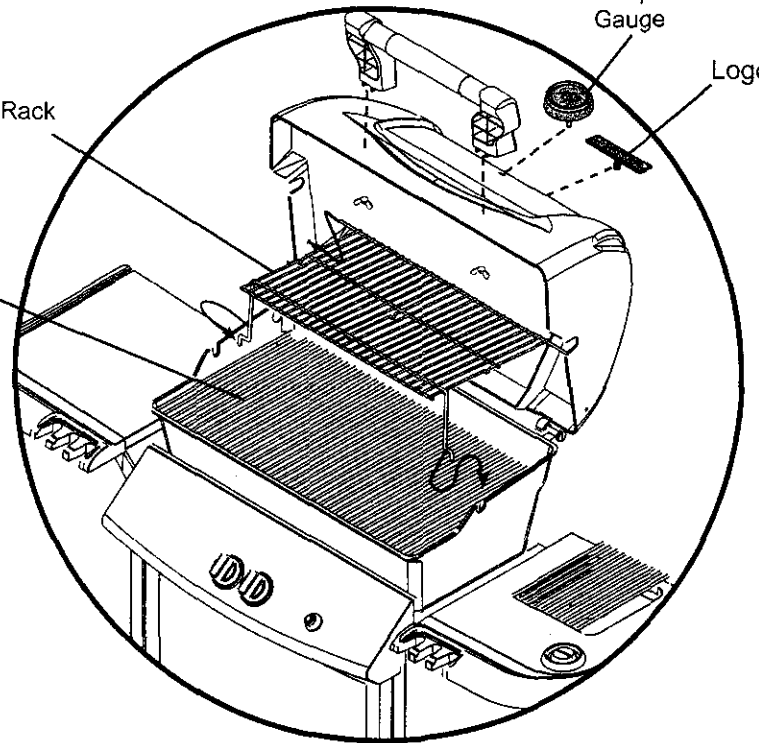

Temperature Gauge

Logo

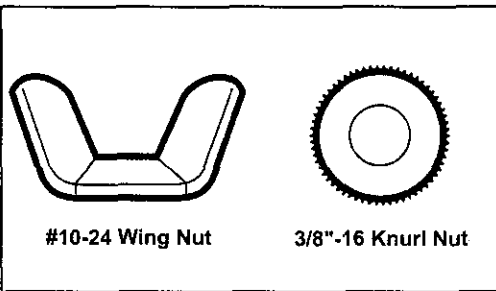

#10-24 Wing Nut

3/8"-16 Knurl Nut

Then place handle assembly onto lid and secure with #10 wingnuts.

NOTE: Tighten wing nuts securely.

Install cooking grids, logo, temperature gauge and warming rack as shown.

16. Install swing griddle hardware in hole provided in side burner base as shown.

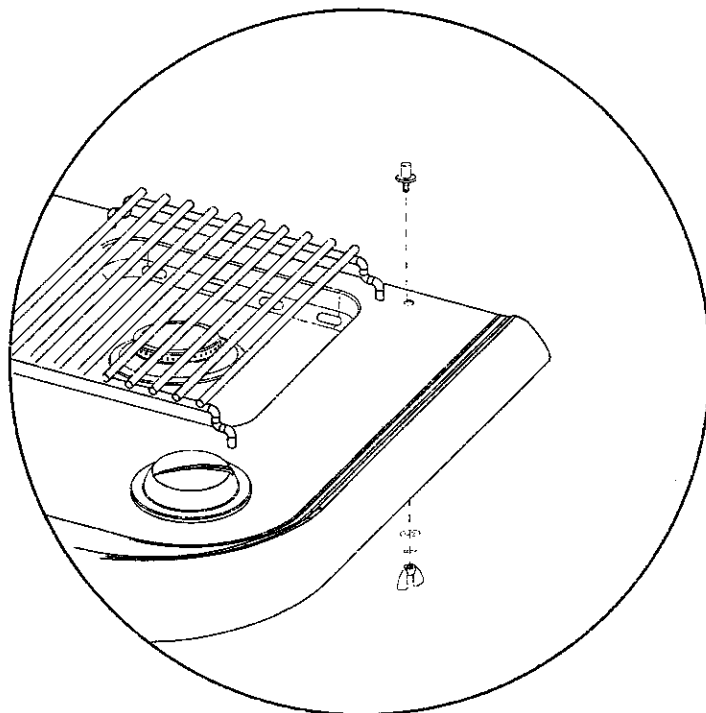

17. Place swing griddle onto mounting pin as shown.

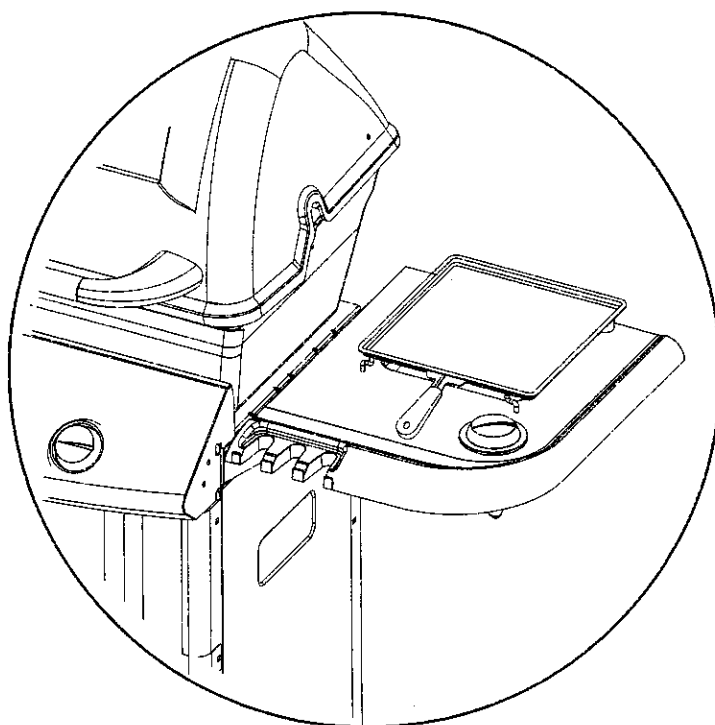
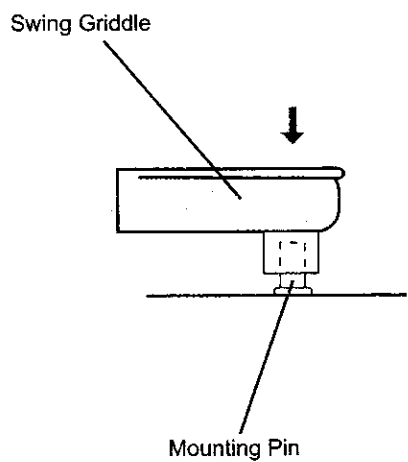

18. Insert Illuminator into slots as shown below, and tighten knurl nuts to illuminator bolts on bottom of shelf plate.
For battery installation see pg. 19

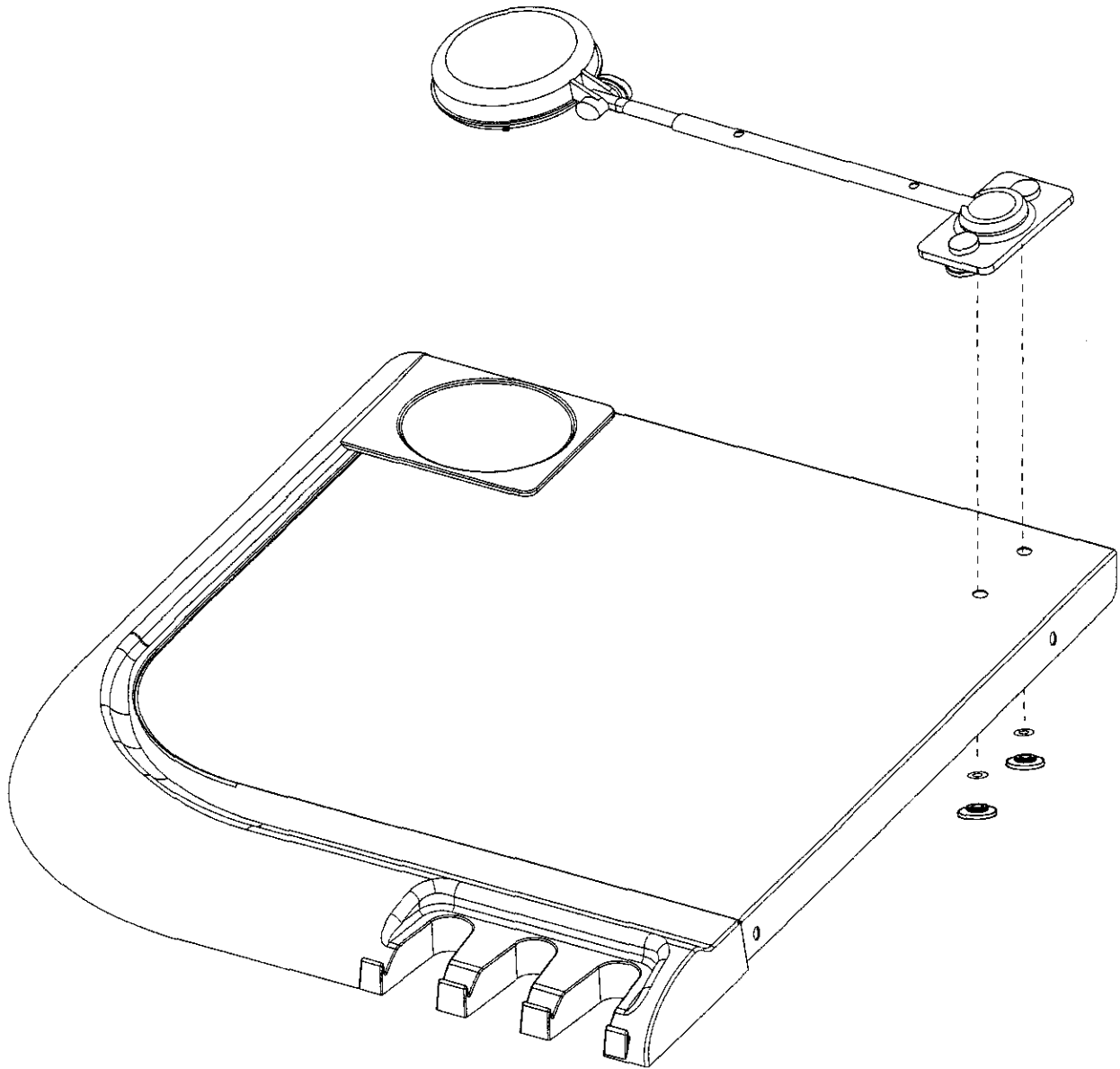

19. Place tank into hole located in bottom plate.
Insert Tank Bracket into Slot and rotate it 90 Degrees.
Slide bracket down over tank ring to hold tank in place.

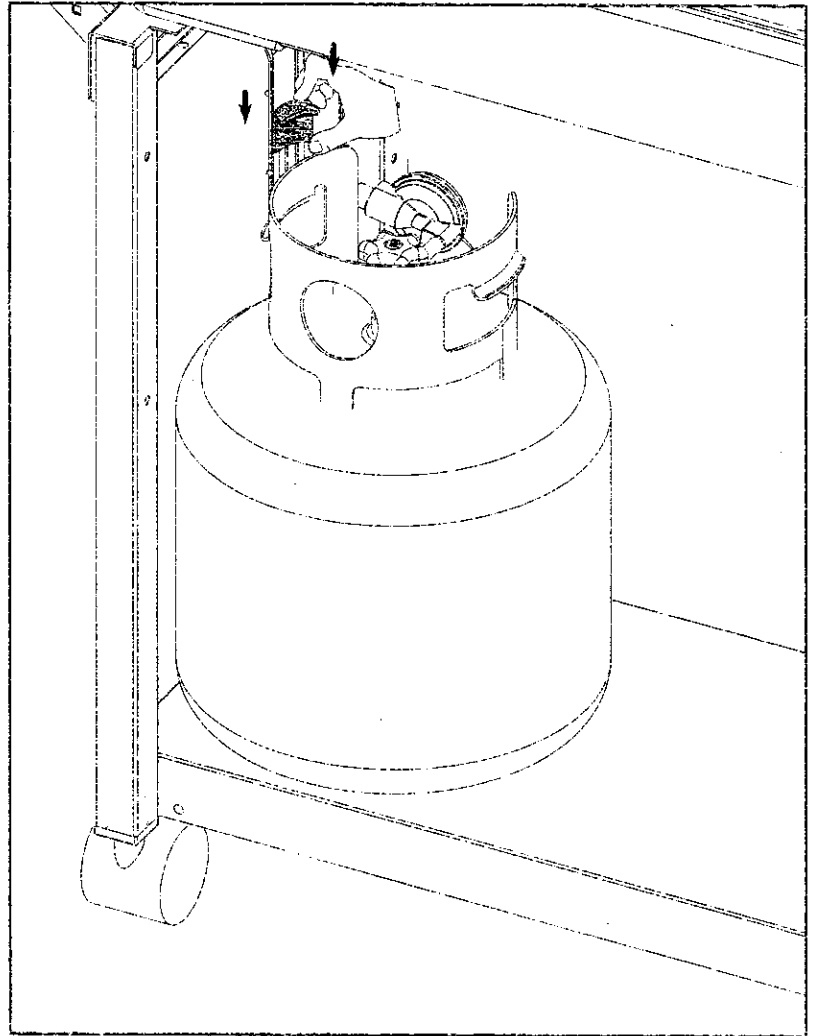
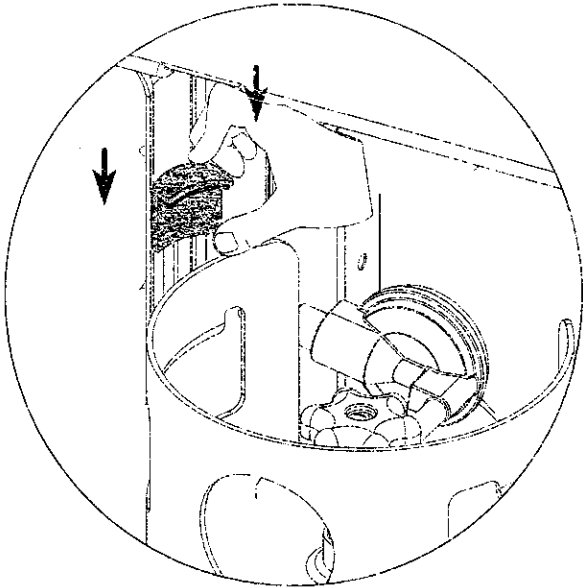

20. Connect regulator to tank valve.

CAUTION  Be sure that hose assembly does not contact the base casting or any other parts which will get hot.

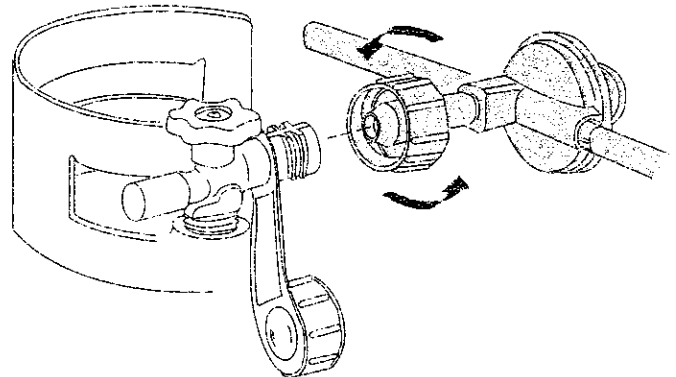

OPERATION

WARNING



Warning: Before proceeding with the following steps, ensure you have read the L.P. Gas Cylinder hose and Regulator sections of this Assembly and Operation Manual. Follow all directions under L.P. Gas Cylinder filling section of this manual.

LIGHTING

Prior to lighting your grill, visually check all hoses before each use for nicks, cracking, abrasions or cuts. If the hose is found to be damaged in any way, **DO NOT USE YOUR GRILL.** A replacement hose and regulator is required (see 'PARTS LIST' in back of book).

IMPORTANT

- Always raise the grill lid before lighting.
- Do not lean over the grill when lighting the burner.
- Visually check the flames every time you light your grill (Figure 8). If the flame is abnormally small or smoky yellow -- shut off the grill and check the venturi tubes for blockage (see Figure 11 on pg. 30) or refer to the Troubleshooting Guide.

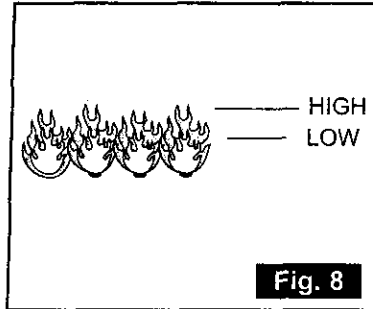

Fig. 8

On grills with Three burners, the right control knob operates the right burner, the left knob operates the left burner, and the center knob operates the center burner.

MATCH LIGHTING PROCEDURE

1. Open the lid before lighting
2. Place an ignited lighter or lit match through the lighting hole. (See Figure 9)
3. Push in and turn the **LEFT** burner control knob to 'HIGH'. The burner should light immediately (within four seconds). If it does not, extinguish the lighter or match, turn the control knob to off, and wait 5 minutes to clear the gas.
4. Repeat steps 1 to 3. If burner fails to light, refer to the Troubleshooting Guide to determine cause and solution.
5. Once left burner is lit push in and turn center burner knob to high. Once it is lit, push in and turn right burner knob to high.

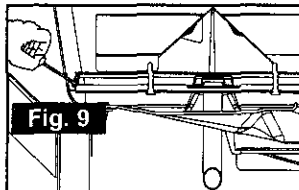

Fig. 9

SIDE BURNER

1. Open L.P. cylinder.
2. Push in and turn the side burner control knob to "HI".
3. Depending on which ignitor you have, turn or depress ignitor. Repeat if necessary.
4. If burner does not light immediately (within four seconds), turn the burner control knob off, and wait 5 minutes to clear the gas.
5. Repeat steps 1 to 4. If burner still fails to light, refer to the Troubleshooting Guide to determine cause and solution, or try the Match Lighting Procedure above.

MATCH LIGHTING PROCEDURE

1. Place an ignited lighter or lit match near the ports, approximately 1/2" (1.25 cm) from burner.
2. Push in and turn the side burner control knob to 'HIGH'. The burner should light immediately (within four seconds). If it does not, extinguish the lighter or match, turn the control knob off, and wait 5 minutes for the gas to clear.
3. Repeat steps 1 and 2. If burner still fails to light, refer to the Troubleshooting Guide to determine the cause and solution.

LOW HEAT OUTPUT

If the heat output from the burner(s) seems abnormally low, it may be caused by the regulator flow-limiting device being activated by a leak in the gas system, or improper lighting procedures. If this is suspected, shut off the cylinder valve and all burner valves. Perform a leak test to determine if a leak has caused the flow-limiting device to activate. If the leak test is negative, then carefully follow the lighting procedures step-by-step, ensuring all valves (including tank) are off before starting.

RELIGHTING

WARNING



If the burner flame goes out when your grill is in operation, immediately turn off the control valves. Wait five minutes for the gas to clear before attempting to relight the burner. If the problem persists, refer to the troubleshooting guide

SHUTTING DOWN YOUR GRILL

1. Shut off L.P. cylinder valve or natural gas main shut-off valve.
 2. Shut off burner control valves.
- This sequence prevents residual gas from being left in the system under pressure.

THE "ILLUMINATOR"

The "Illuminator" grill light has the batteries included in the box. The batteries should be installed in the light unit located in the light head assembly. To detach light unit from the housing, grasp the housing firmly with one hand and turn the clear lens counter clockwise slightly with the other hand until the unit becomes loose and can be removed. The battery compartment is located on the back of the light unit. To place the light unit back into the housing, line up the three mounting tabs on the unit with the three mounting points on the housing. Be sure the word "TOP" molded into the lens is positioned at the top of the light and that the rubber seal is positioned properly. Press in on the unit and turn it slightly clockwise until it is locked into position.

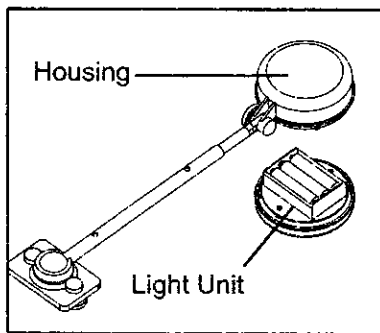

NOTE: This light unit has an automatic internal switch that turns the light on when the light head is raised up from its horizontal resting position. The light may come on as soon as you put the batteries in. You can lay the light with the lens facing down on a flat surface and it will go off.

To use the Illuminator, simply pivot the light from its resting position and then rotate it forward and position it as desired. The light will stay on as long as the light head is approximately 20 degrees or more from horizontal. The light support shaft can be adjusted in length by pressing the release button and sliding the light head in or out as desired.

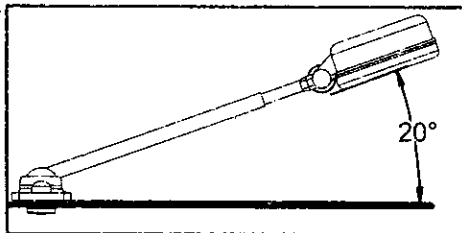

SWING GRIDDLE

Do not overload the swing griddle. A maximum weight of 2 lbs is specified.

Remove the swing griddle or swing it out of the way when lighting the side burner.

Remove the swing griddle when cooking with other utensils on the side burner.

The side burner grid must be in place when cooking with the swing griddle.

During usage your griddle rests on top of the side burner cooking grid.

Clean your swing griddle just as you would any similar cooking utensil.

Use of metal spatula could damage non-stick coating of swing griddle.

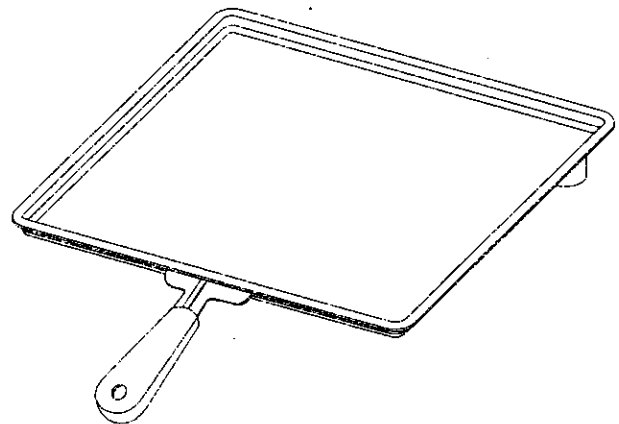

When not in use store Swing Griddle in space between front panel and bottom pan.

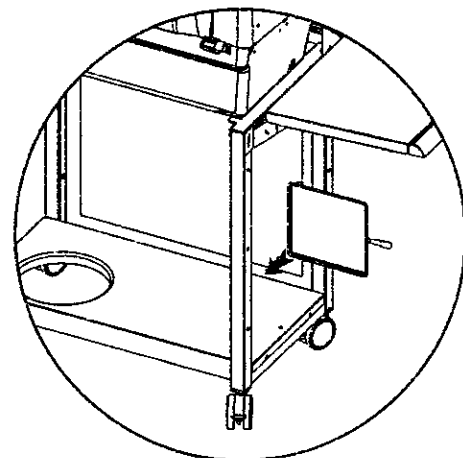

BREAKING IN YOUR GRILL

Before cooking on your gas grill for the first time, you should "break it in" by operating it for a short period of time without any food.

To "break in" your grill light the grill following the lighting instructions as outlined on the console decal or in this manual. (see page 27) . Close the lid and keep the temperature on "HIGH" for 15 minutes. **DO NOT OPEN THE LID DURING THIS PERIOD.** Then raise the lid and continue to operate your grill on "HIGH" for an additional 5 minutes. Your grill is now ready for cooking.

COOKING TECHNIQUES

PREHEATING THE GRILL

The cooking system and grids require heating prior to adding food.

1. Light your grill as outlined in the 'LIGHTING' instruction section.
2. Once lit, preheat your grill on the HIGH setting with the lid down for 6 to 10 minutes.
3. Turn the burner control knobs to the appropriate heat setting prior to adding your food. Preheating your grill is not required when you are cooking food using the indirect cooking or rotisserie cooking techniques.

LID POSITION

Although keeping the lid up or down when cooking on your grill is a personal preference, you will find that you will have fewer flare-ups, and your food will cook in less time (therefore using less fuel) if the lid is down. Keep the lid down when cooking food that requires a long cooking period over a low flame, such as when rotisserie or indirect cooking.

COOKING TEMPERATURES

HIGH Setting: Use the HIGH setting to preheat the grill, sear meat such as steak, and to burn off any cooking residue from the grids after cooking your meal. HIGH is rarely used for extended cooking.

MEDIUM Setting: Most grilling or roasting of meat and vegetables, as well as any baking, is best done at a medium heat.

LOW Setting: A low temperature is used when cooking lean meat or delicate items such as fish. All rotisserie and smoke cooking is done at low heat.

GRILL COOKING METHODS

Your grill is more than just a place to grill your burgers and hotdogs - the possibilities are as endless as your imagination. But, before you start experimenting, here are some frequently used terms that will help:

Direct Cooking is also known as grilling. This is the most popular cooking method and involves cooking food directly over the flame, such as searing a steak. Other good candidates for this cooking method are thin cuts of meat, vegetables, kabobs and fillets.

Indirect Cooking means the food is cooked away from the direct flame by placing it on the opposite side of the lit burner and allowing the heat to tumble within the closed confines of the closed grill, very similar to a convection oven. Much like your oven, you can roast and even bake, provided your grill lid is closed.

WARMING RACKS

A warming rack may be included with your grill and provides you with additional cooking space away from direct heat. This is useful when cooking delicate items such as fish, boneless chicken breasts or vegetables. Warming racks are also a great place to keep food warm that is already done so you can serve your entire meal at the same time.

Tip: A light application of cooking oil prior to use will help to keep food from sticking to the warming rack.

CONTROLLING FLARE-UPS

Some flare-up during grilling is desirable to create the smoke, which gives grilled food its unique flavor and appearance. However, excessive flare-up can not only ruin your food, it may lead to a dangerous condition as well. By excessively raising the temperature within your grill, particularly if a build up of grease in your grill ignites, these flare-ups may result in an uncontrolled grease fire. Grease fires can occur if grease is allowed to build up in your grill. Follow instructions for keeping your grill clean. Do not leave your grill unattended when burners are on, including warm-up and burn-off periods.

In the event of a grease fire, turn burner valves off and close LP tank valve.

DO NOT ATTEMPT TO PUT A GREASE FIRE OUT WITH WATER.

DO NOT REACH OVER FLAMES TO OPEN OR CLOSE LID.

TO MINIMIZE FLARE-UPS:

- Trim excess fat from meats before cooking.
- Cook fatty meats on a low setting, or use the indirect method described above.
- Ensure that your cooking system is free of excess grease from previous usage.
- Check that the grease drain hole is not blocked.
- Cook with lid down to cut down on the flow of air.
- Reduce the heat settings.

CLEANING & MAINTENANCE

To keep your grill working at its peak efficiency as well as contribute to the safe operation of this unit, perform all of the operations below at least once a year -- preferably at the start of each cooking season.

PERFORM A LEAK TEST

A leak test ensures that there are no gas leaks prior to lighting your grill.

WHEN A LEAK TEST MUST BE PERFORMED:

- Before lighting your grill for the first time.
- Every time the propane cylinder is refilled
- If any gas component is changed
- At a minimum once per season.
- After prolonged period of storage or non-use.
- If the regulator flow-limiting device has been activated.

The leak test should be performed in a well-ventilated area away from any open flame, heat or ignition sources. **DO NOT USE A MATCH, OPEN FLAME OR SMOKE DURING LEAK TESTING.**

WHAT YOU'LL NEED FOR TESTING:

1. A mixture of 50% liquid dish soap and 50% water.
2. A brush or cloth to apply the mixture.

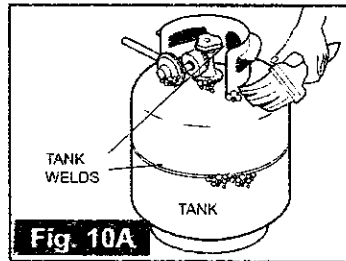

AREAS TO TEST ON PROPANE GRILLS:

- All propane cylinder welds (see Figure 10A)
- Propane cylinder valve -- including threads into cylinder (see Figure 10B)
- Regulator fitting and propane cylinder connection (see Figure 10B)
- All hose connections (see Figure 10C) including side burner tubing, if equipped (see Figure 10D)
- All valve connections (see Figure 10C & 10D)

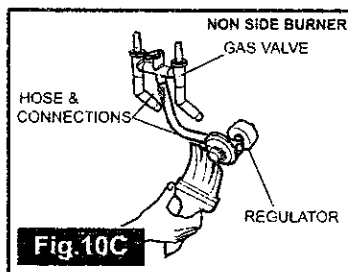
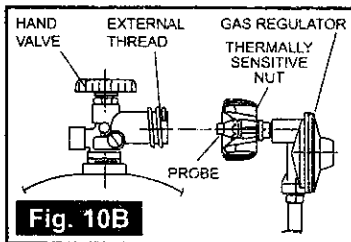

AREAS TO TEST ON NATURAL GAS GRILLS:

- All hose connections (see Figure 10C)
- All valve connections (see Figure 10C & 10D)

HOW TO DO THE TESTING:

1. With the grill console control knobs in the 'OFF' position, twist the valve on your propane cylinder 1 turn, or the main natural gas valve on. **DO NOT IGNITE THE BURNERS WHILE PERFORMING THE LEAK CHECK.**
2. Brush your soap and water solution on all connections and components as outlined above.
3. Observe each place for growing bubbles, which indicate that a leak is present.
4. Shut off the flow of gas while fixing the leak. Tighten any leaking connection and repeat test until no leaks are detected.
5. If the leak(s) cannot be stopped DO NOT USE Shut off the fuel source at the valve immediately (if appropriate, remove propane cylinder). Call a certified gas appliance service person, or a gas dealer for proper repairs.

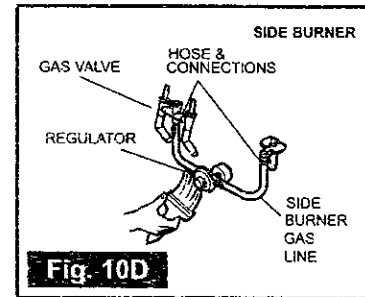

WARNING



Failure to ensure the above may result in a hazardous fire or explosion causing serious bodily injury and/or property damage.

CLEANING VENTURI TUBES

Periodic cleaning of the venturi tubes is recommended for optimum burner performance, especially after prolonged storage or a period of non-use.

How to Clean:

- Remove the burner (refer to 'ASSEMBLY PROCEDURE')
- Use a venturi cleaning brush, bottle brush or stiff wire and insert into the venturi tube approximately 1 inch at a time, removing after each inch to prevent pushing any debris further into the tube. (see Figure 11)
- As you remove the brush head inspect and discard any debris
- Continue this procedure until the entire lengths of all venturi tubes are free of debris
- Reinstall burner (as per assembly instructions), ensure the venturi tubes are seated over the valve orifices (see Figure 1)
- Perform a Leak Test.

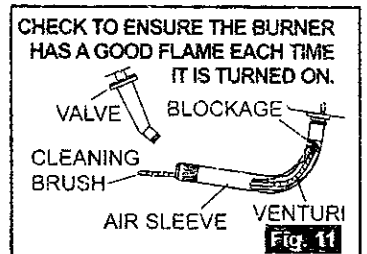

WARNING

It is possible that very small insects could make webs or nest in the venturi tubes. This will partially or completely block the flow of gas through the venturi and is indicated by a smoky yellow flame, and/or a burner that is difficult or impossible to light. Ultimately, it may cause the gas to burn outside the venturis, which can cause a fire resulting in damage to your grill and potential personal injury. **IF THIS HAPPENS IMMEDIATELY SHUT OFF THE PROPANE AT CYLINDER, OR NATURAL GAS AT MAIN SHUT-OFF VALVE.** When the grill has cooled, follow the "Cleaning Venturi tubes" steps

CLEANING OTHER PARTS OF YOUR APPLIANCE**BURNER:**

At least twice a year, clean your burner when cleaning the venturi tubes. The burner can be gently scraped clean with a brass bristle brush. Ensure that all burner ports (openings) are clear (**DO NOT ENLARGE BURNER PORTS**). If you find cracks, abnormal holes, or damage caused by corrosion during your inspection and cleaning, replace burner with appropriate part as listed on the part list.

IGNITOR:

Clean the ignitor clip lightly using a wire brush to remove rust and grease. **DO NOT USE WATER OR CLEAN THE ELECTRODES.** Visually inspect the ceramic of the electrode for cracks. The electrode can be wiped with a soft cloth if necessary. If a crack is found, a replacement ignitor system will be required, look for O.E.M. ignition system or universal ignition system.

CLEANING GRIDS:

After each use, scrub the cooking grids with a stiff long-handled brass brush. Do not use steel brushes, as they can scratch the nickel or porcelain coating. Grids can also be washed with mild detergent. Never use commercial oven cleaners. If rust appears on your cooking grids, remove the rust with a scrub pad and coat the grid with some cooking oil. If excessive wear is evident, you might want to replace or upgrade your cooking grid.

COOKING SYSTEM:

To clean your Heat Distribution Plate scrape it with a brass bristle brush; clean using soap and water, then rinse and dry. **DO NOT ALLOW EXCESSIVE GREASE OR OTHER RESIDUE TO BUILD UP ON YOUR COOKING SYSTEM AS A FIRE MAY RESULT.**

SIDE SHELVES:

Metal Shelves: Use any household cleaner, except those containing acid or mineral spirits. Be sure to rinse well after cleaning. **DO NOT USE AS A CUTTING BOARD.**

Plastic Shelves and Panels: Clean with dish washing liquid, then wipe dry. **DO NOT USE AS A CUTTING BOARD.**

COVER YOUR GRILL WHEN IT IS NOT IN USE TO PROTECT THE SHELVES FROM THE OUTDOOR ELEMENTS.

GRILL EXTERIOR :

The white spots that may appear on the outside of the casting are caused by the oxidation of the aluminum. This oxidation can usually be removed with soap and water. If not, you can repaint the outside casting using hi-heat grill paint.

GRILL INTERIOR, WARMING RACK:

At least once a year remove all components from inside your grill. Loosen any cooking residue with a scraping tool for large particles and a brass brush for smaller particles. Scrub with hot water and a strong detergent, then rinse thoroughly or spray grill degreaser liberally on all interior surfaces. Be sure to use gloves and eye protection. Let stand for 10 minutes, scrape off residue and repeat if required. Rinse thoroughly with water. Replace all components as outlined in the assembly instructions. **DO NOT USE DEGREASER ON PAINTED OR PLASTIC SURFACES.**

STORAGE

More people are discovering the pleasure of year round grilling. However, if you choose to store your grill for the winter or any extended length of time, follow these steps:

- Clean the cooking grids, then oil lightly with cooking oil, wrap in paper and then store the cooking grids indoors.
- Follow the same cleaning method above for the burners and any warming racks.
- Cover the grill if it is left outdoors.
- When the grill is not in use, the gas must be turned off at the L.P. cylinder valve or main shut off valve, and stored outdoors in a well-ventilated area.

With a **Propane** appliance you can store the grill inside, **PROVIDED** the cylinder is removed from the grill and stored outdoors in a well-ventilated area, out of the reach of children. When the cylinder is disconnected from the grill, ensure the cylinder valve safety cap is firmly in place.

After a period of storage or non-use, a leak test should be performed and the burner venturis cleaned prior to use.

PART LIST

Kenmore Propane Gas Grill

| REF # | PART # | QTY | DESCRIPTION |
|-------|-------------|-----|-----------------------------------|
| 1. | SP5051-26 | 1 | Logo |
| 2. | SM5004-1B | 1 | Lid |
| 3. | SP5002-30 | 1 | Temperature Gauge |
| 4. | SP5024-19 | 1 | Left Hand Handle End |
| 5. | SM5050-42E | 1 | Handle Tube |
| 6. | SP5023-19 | 1 | Right Hand Handle End |
| 7. | SP5000-16 | 2 | Wing Nut |
| 8. | SP5091-24 | 1 | Illuminator |
| 9. | SP5003-16 | 2 | Knurl Nut |
| 10. | SP66-3 | 2 | Cooking Grid |
| 11. | SP5012-3 | 1 | Warming Rack |
| 12. | SP56-9 | 1 | Smart Bar |
| 13. | SM5025-12 | 1 | H Burner |
| 14. | SP25-16 | 2 | Wide Body Wingnut |
| 15. | SM5035-9E | 1 | LH Shelf Insert |
| 16. | SP5026-9B | 1 | LH Shelf Trim |
| 17. | SP5005-16 | 22 | Tapered Wingnut |
| 18. | SM5040-6B | 1 | Left Rear Shelf Bracket |
| 19. | SP5012-18 | 16 | Carriage Bolt 1/4 x 20 x 1/2" |
| 20. | SM5043-6B | 1 | Left Front Shelf Bracket |
| 21. | SM5184B-42B | 1 | LH Leg Assembly |
| 22. | SM5027-4 | 1 | HVR Assembly |
| 23. | SM5038-6B | 1 | Back Support |
| 24. | SP5001-22 | 2 | Locking Caster |
| 25. | SP5015-18 | 4 | Phillips Drive 1/4 x 20 x 2" Bolt |
| 26. | SM5051-9B | 1 | Stamped Steel Front Panel |
| 27. | SM5024A-9B | 1 | Bottom Pan |
| 28. | SP5000-22 | 2 | Non-Locking Caster |
| 29. | SP5000-33 | 4 | Caster Plug |
| 30. | SP21-6 | 1 | Tank Clip |
| 31. | SM5185B-42B | 1 | RH Leg Assembly |
| 32. | SM5044-6B | 1 | Right Front Shelf Bracket |
| 33. | SP47-18 | 2 | Knurl Screw |
| 34. | SM5244-42E | 1 | Console Assembly |
| 35. | SM5041-6B | 1 | Right Rear Shelf Bracket |
| 36. | SP5028-9B | 1 | RH Shelf Trim |
| 37. | SM5183-42E | 1 | Side Burner Base |
| 38. | SP5005-15 | 1 | Hinge Clip |
| 39. | SM47-2B | 1 | Base |
| 40. | SP10-7 | 2 | Knob |
| 41. | GG20-27 | 1 | Tank (Not Included) |
| 42. | SP5001-7 | 1 | Side Burner Knob |
| 43. | SP5007-6 | 1 | Side Burner Valve Bracket |
| 44. | SP5093-12 | 1 | Side Burner |
| 45. | SP5017-3 | 1 | Side Burner Cooking Grid |
| 46. | SP5090-24 | 1 | Swing Griddle |
| 47. | SP6-15 | 1 | Grease Cup Clip |
| 48. | SP5017-20 | 1 | Ignitor Clip |
| 49. | SP5011-18 | 2 | Carriage Bolt 1/4 x 20 x 2" |
| 50. | SP5006-20 | 1 | Ground Wire |

EXPLODED VIEW

Kenmore Propane Gas Grill

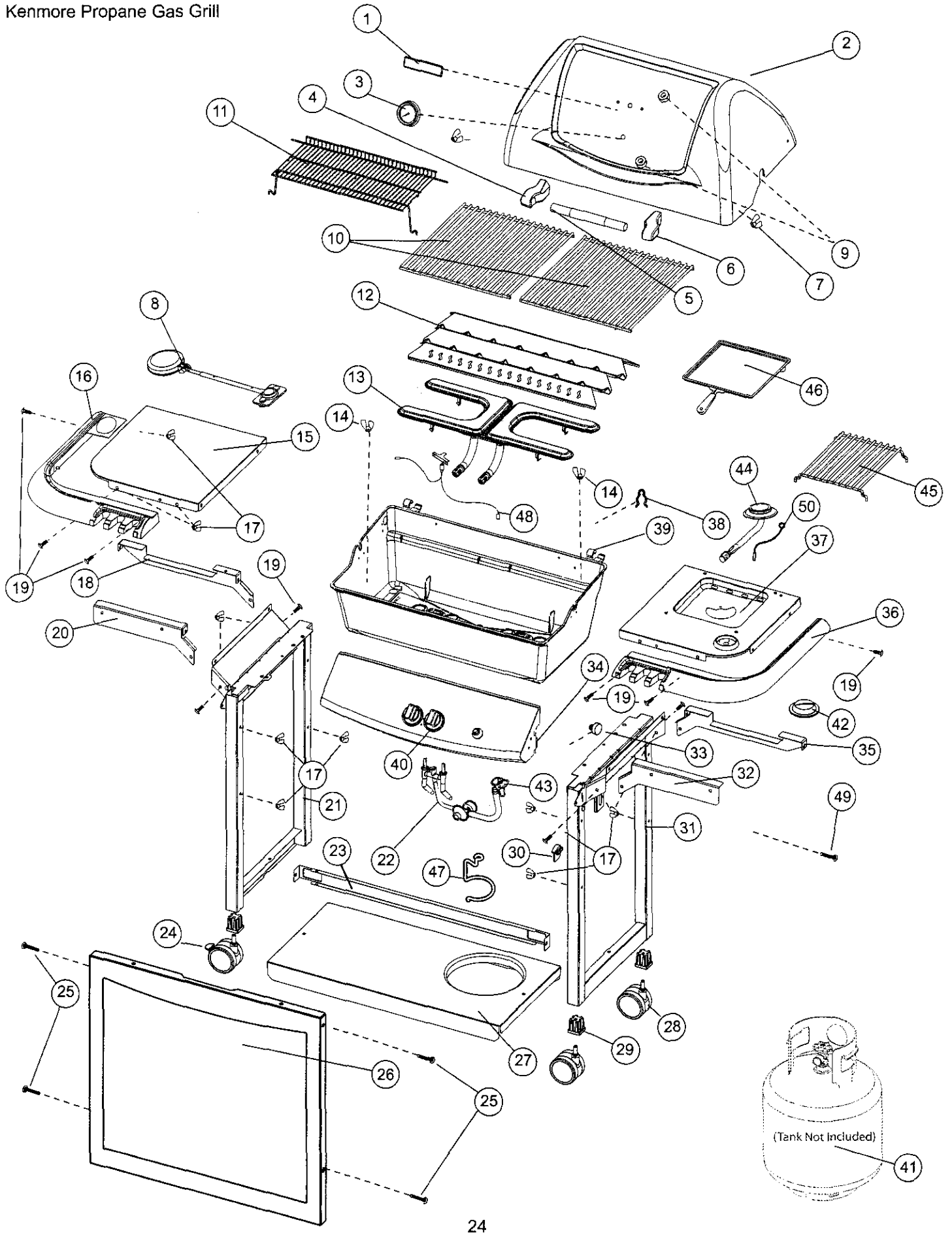

TROUBLESHOOTING GUIDE

IF YOU ARE EXPERIENCING DIFFICULTY AFTER FOLLOWING THIS GUIDE, PLEASE CONTACT OUR CUSTOMER SERVICE TOLL FREE - PHONE 1-800-396-3838 OR FAX 1-615-441-2941.

| | |
|---------------------------------------------------------------------------------|------------------------------------------------------------------------------------------------------------------------------------------------------------------------------------------------------------------------------------------------------------------------------------------------------------------------------------------------------------------------------------------------------------------------------------------------------------------------------------------------------------------------------|
| 1. Burners will not light. | Out of propane? Is venturi properly seated over orifice? Inspect both venturis and burner holes for obstructions. Check ignition spark. Is cylinder valve turned on? Regulator assembly not fully tightened to cylinder valve? If you have electronic ignitor, is the battery good? |
| 2. Flame burns out on "Low" | Has grill been sufficiently preheated before turning to "Low"? Is venturi properly seated over orifice? Inspect both venturis and burner holes for obstructions. |
| 3. Burners are not hot enough | Your grill is equipped with a flow limiting device intended to reduce the flow of gas in the event of a leak. This device can also be activated if you do not follow the correct lighting procedure. Follow proper lighting sequence (see page 23) or correct leak in system (see page 25) as instructed. Inspect venturi, orifice, burner holes and heat control valves for obstructions and alignment. Make sure burners and heat distribution system (heat distribution plates, lava rock, briquettes or tiles) is clean. |
| 4. Flame smokey yellow. | Check to see if burners and venturis are clean (See page 26). Check for proper air shutter opening in venturis.(Side Burner Only) |
| 5. Console Fire (Flame coming up venturi around console /control knobs). | Immediately shut off gas supply at tank valve. Allow grill to cool. Remove burners and check venturis and orifices for obstructions. |
| 6. Grease dripping from base | Is grease tray properly installed? Is it full of grease? Check to ensure bolts are tight, washers are in place. Check that grill is level. |
| 7. Regulator Humming. | This is not a defect or hazard. The noise is internal and caused by cold propane passing through a restricted passage.(Usually with a full tank in hot weather. This will subside after a short period of operation) |
| 8. Burner lights with match, not with ignitor. | Broken wire or electrode. Defective ignitor or switch. Obstructions in venturi. If you have electronic ignitor, is the battery good? |
| 9. Too much heat. | Excessive grease build-up ("Grease fire"). Damaged or missing orifice. Faulty regulator. Restricted heat flow through grill. |
| 10. Excessive flare-up. | Reduce temperature. Clogged grease drain. Overload of fatty meat. Close lid to contain flare-up. |
| 11. Incomplete burner flame | Plugged, leaking or rusted burner. |
| 12. Propane tank will not fill. | If during filling, the overfill protection device (O.P.D.) trips prior to tank being full, invert tank briefly to reset O.P.D. |

Notes

Get it fixed, at your home or ours!

Your Home

For repair – in **your home** – of **all** major brand appliances, lawn and garden equipment, or heating and cooling systems, **no matter who made it, no matter who sold it!**

For the replacement parts, accessories and owner's manuals that you need to do-it-yourself.

For Sears professional installation of home appliances and items like garage door openers and water heaters.

1-800-4-MY-HOME® (1-800-469-4663)

Call anytime, day or night (U.S.A. and Canada)

www.sears.com www.sears.ca

Our Home

For repair of carry-in items like vacuums, lawn equipment, and electronics, call or go on-line for the location of your nearest

Sears Parts & Repair Center.

1-800-488-1222

Call anytime, day or night (U.S.A. only)

www.sears.com

To purchase a protection agreement (U.S.A.)
or maintenance agreement (Canada) on a product serviced by Sears:

1-800-827-6655 (U.S.A.)

1-800-361-6665 (Canada)

Para pedir servicio de reparación
a domicilio, y para ordenar piezas:

1-888-SU-HOGARSM

(1-888-784-6427)

Au Canada pour service en français:

1-800-LE-FOYER^{MC}

(1-800-533-6937)

www.sears.ca

The Sears logo is displayed in a large, bold, serif font. The word "Sears" is written in a dark, slightly shadowed style, giving it a three-dimensional appearance. A thin, curved line underlines the bottom of the letters.

© Registered Trademark / TM Trademark / SM Service Mark of Sears, Roebuck and Co.

© Marca Registrada / TM Marca de Fábrica / SM Marca de Servicio de Sears, Roebuck and Co.

^{MC} Marque de commerce / ^{MD} Marque déposée de Sears, Roebuck and Co.

© Sears, Roebuck and Co.