

Digital Palmcorder®

Panasonic®

Digital Video Camcorder Operating Instructions

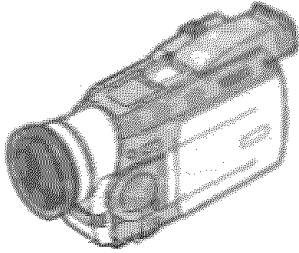

Models No. **PV-DV901**
PV-DV851

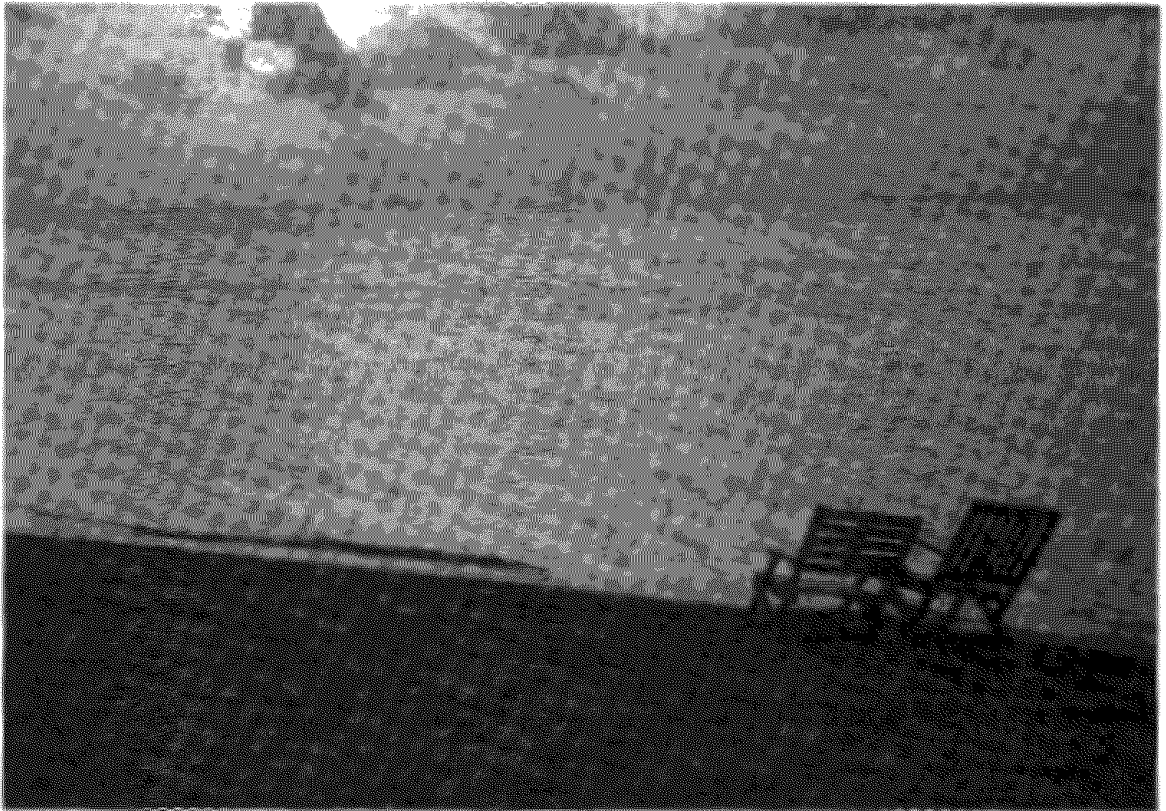

MultiMediaCard™



Mini **DV**

Before attempting to connect, operate or adjust this product, please read these instructions thoroughly. Spanish Quick Use Guide is included.

Guía para rápida consulta en español está incluida.

For assistance, please call 1-800-211-PANA(7262) or send e-mail to consumerproducts@panasonic.com

LSQT0438B

Things You Should Know

Thank you for choosing Panasonic!

You have purchased one of the most sophisticated and reliable products on the market today. Used properly, we're sure it will bring you and your family years of enjoyment. Please take time to fill in the information below. The serial number is on the tag located on the underside of your Palmcorder. Be sure to retain this manual as your convenient Palmcorder information source.

Date of Purchase _____

Dealer Purchased From _____

Dealer Address _____

Dealer Phone No. _____





Model No. _____

Serial No. _____

Safety Precautions

**WARNING: TO PREVENT FIRE OR SHOCK HAZARD,
DO NOT EXPOSE THIS EQUIPMENT TO RAIN OR MOISTURE.**

Your **IX** Palmcorder is designed to record and play back in Standard Play (SP) mode and Long Play (LP) mode. It is recommended that only cassette tapes that have been tested and inspected for use in Palmcorder with the **IX** mark be used.

	CAUTION RISK OF ELECTRIC SHOCK DO NOT OPEN			This symbol warns the user that uninsulated voltage within the unit may have sufficient magnitude to cause electric shock. Therefore, it is dangerous to make any kind of contact with any inside part of this unit.
CAUTION: TO REDUCE THE RISK OF ELECTRIC SHOCK, DO NOT REMOVE COVER (OR BACK) NO USER-SERVICEABLE PARTS INSIDE RÉFER SERVICING TO QUALIFIED SERVICE PERSONNEL				This symbol alerts the user that important literature concerning the operation and maintenance of this unit has been included. Therefore, it should be read carefully in order to avoid any problems.

The above markings are located on the appliance bottom cover.

Note: This equipment has been tested and found to comply with Part 15 of the FCC Rules. These limits are designed to provide reasonable protection against harmful interference when operated in a residential environment.

If this equipment does cause interference to radio or television reception, which can be determined by turning the equipment off and on, use the equipment in another location and/or utilize an electrical outlet different from that used by the receiver.

If necessary, consult the dealer or an experienced radio/TV technician for help. You may find the booklet, 'Something About Interference' available from FCC local regional offices helpful.

FCC Warning:

- To assure continued FCC compliance, use only the provided shielded interface cable with ferrite core when connecting digital Palmcorder to computer in accordance with instruction herein. Also, any unauthorized changes or modifications to this equipment could void the user's authority to operate.
- Any unauthorized changes or modifications to this equipment would void the user's authority to operate this devices.

Declaration of Conformity

Model No.: PV-DV851/PV-DV901/BN-SDCAA

Trade Name: Panasonic

Responsible party: Matsushita Electric Corporation of America

Address: One Panasonic Way, Secaucus, New Jersey 07094

Telephone number: 1-800-211-PANA (7262)

This device complies with Part 15 of the FCC Rules. Operation is subject to the following two conditions: (1) This device may not cause harmful interference, and (2) this device must accept any interference received, including interference that may cause undesired operation.

Important Safeguards

- 1) **Read Instructions** — All the safety and operating instructions should be read before the unit is operated.
- 2) **Retain Instructions** — The safety and operating instructions should be retained for future reference.
- 3) **Heed Warnings** — All warnings on the unit and in the operating instructions should be adhered to.
- 4) **Follow Instructions** — All operating and maintenance instructions should be followed.
- 5) **Cleaning** — Unplug this video unit from the wall outlet before cleaning. Do not use liquid or aerosol cleaners. Use a dry cloth for cleaning.
- 6) **Attachments** — Do not use attachments not recommended by the video product manufacturer as they may be hazardous.
- 7) **Water and Moisture** — Do not use this video unit near water- for example near a bath tub, wash bowl, kitchen sink, or laundry tub, in a wet basement, or near a swimming pool, and the like.
- 8) **Accessories** — Do not place this video unit on an unstable cart, stand, tripod, bracket, or table. The video unit may fall, causing serious injury to a child or adult, and serious damage to the unit. Use only with a cart, stand, tripod, bracket, or table recommended by the manufacturer, or sold with the video unit. Any mounting of the unit should follow the manufacturer's instructions and should use a mounting accessory recommended by the manufacturer. An appliance and cart combination should be moved with care. Quick stops, excessive force, and uneven surfaces may cause the appliance and cart combination to overturn.
- 9) **Ventilation** — Slots and openings in the cabinet are provided for ventilation and to ensure reliable operation of the video unit and to protect it from overheating. These openings must not be blocked or covered. Never place the video unit on a bed, sofa, rug, or other similar surface, or near or over a radiator or heat register. This video unit should not be placed in a built-in installation such as a bookcase or rack unless proper ventilation is provided or the manufacturer's instructions have been adhered to.
- 10) **Power Sources** — This video unit should be operated only from the type of power source indicated on the marking label. If you are not sure of the type of power supply to your home, consult your appliance dealer or local power company. For video units intended to be operated from battery power, or other sources, refer to the operating instructions.



- 11) **Grounding or Polarization** — This video unit may be equipped with either a polarized 2-wire AC (Alternating Current) line plug (a plug having one blade wider than the other) or 3-wire grounding type plug, a plug having a third (grounding) pin.
The 2-wire polarized plug will fit into the power outlet only one way. This is a safety feature. If you are unable to insert the plug fully into the outlet, try reversing the plug. If the plug still fails to fit, contact your electrician to replace your obsolete outlet. Do not defeat the safety purpose of the polarized plug.
The 3-wire grounding type plug will fit into a grounding type power outlet. This is a safety feature. If you are unable to insert the plug into the outlet, contact your electrician to replace your obsolete outlet. Do not defeat the safety purpose of the grounding type plug.
- 12) **Power-Cord Protection** — Power-supply cords should be routed so that they are not likely to be walked on or pinched by items placed upon or against them, paying particular attention to cords of plugs, convenience receptacles, and the point where they exit from the unit.
- 13) **Outdoor Antenna Grounding** — If an outside antenna or cable system is connected to the video unit, be sure the antenna or cable system is grounded so as to provide some protection against voltage surges and built-up static charges. Part 1 of the Canadian Electrical Code, in USA Section 810 of the National Electrical Code, provides information with respect to proper grounding of the mast and supporting structure, grounding of the lead-in wire to an antenna discharge unit, size of grounding conductors, location of antenna discharge unit, connection to grounding electrodes, and requirements for the grounding electrode.

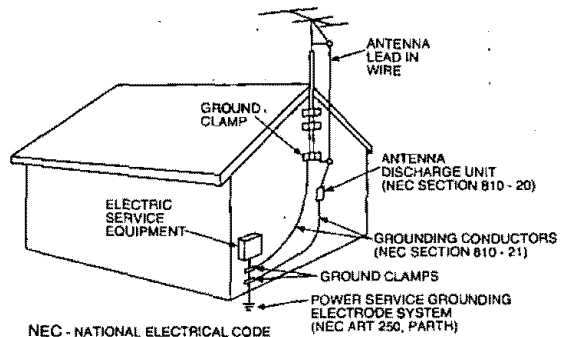

- 14) **Lightning** — For added protection of this video unit receiver during a lightning storm, or when it is left unattended and unused for long periods of time, unplug it from the wall outlet and disconnect the antenna or cable system. This will prevent damage to the video unit due to lightning and power-line surges.
- 15) **Power Lines** — An outside antenna system should not be located in the vicinity of overhead power lines or other electric light or power circuits, or where it can fall into such power lines or circuits. When installing an outside antenna system, extreme care should be taken to keep from touching such power lines or circuits as contact with them might be fatal.
- 16) **Overloading** — Do not overload wall outlets and extension cords as this can result in a risk of fire or electric shock.

Important Safeguards

- 17) **Objects and Liquids** — Never push objects of any kind into this video unit through openings as they may touch dangerous voltage points or short out parts that could result in a fire or electric shock. Never spill liquid of any kind onto the video unit.
- 18) **Servicing** — Do not attempt to service this video unit yourself as opening or removing covers may expose you to dangerous voltage or other hazards. Refer all servicing to qualified service personnel.
- 19) **Damage Requiring Service** — Unplug this video unit from the wall outlet and refer servicing to qualified service personnel under the following conditions:
 - a. When the power-supply cord or plug is damaged.
 - b. If any liquid has been spilled into, or objects have fallen onto, the video unit.
 - c. If the video unit has been exposed to rain or water.
 - d. If the video unit does not operate normally by following the operating instructions. Adjust only those controls that are covered by the operating instructions, as an improper adjustment of other controls may result in damage and will often require extensive work by a qualified technician to restore the video unit to its normal operation.
 - e. If the video unit has been dropped or the cabinet has been damaged.
 - f. When the video unit exhibits a distinct change in performance — this indicates a need for service.
- 20) **Replacement Parts** — When replacement parts are required, be sure the service technician has used replacement parts specified by the manufacturer or have the same characteristics as the original part. Unauthorized substitutions may result in fire, electric shock or other hazards.
- 21) **Safety Check**— Upon completion of any service or repairs to this video unit, ask the service technician to perform safety checks to determine that the video unit is in safe operating order.

Precautions

USE & LOCATION

- **TO AVOID SHOCK HAZARD** ... Your Palmcorder and power supply should not be exposed to rain or moisture. Do not connect the power supply or operate your Palmcorder if it gets wet. Your Palmcorder has been designed for outdoor use, however it is not designed to sustain direct exposure to water, rain, sleet, snow, sand, dust, or a direct splashing from a pool or even a cup of coffee. This action could permanently damage the internal parts of your Palmcorder. Do not attempt to disassemble this unit. There are no user serviceable parts inside. Unplug your Palmcorder from the power supply before cleaning.
- **DO NOT AIM YOUR PALMCORDER AT THE SUN OR OTHER BRIGHT OBJECTS**
- **DO NOT LEAVE THE PALMCORDER WITH THE EVF AIMED DIRECTLY AT THE SUN AS THIS MAY CAUSE DAMAGE TO THE INTERNAL PARTS OF THE EVF**
- **DO NOT EXPOSE YOUR PALMCORDER TO EXTENDED HIGH TEMPERATURE** ... Such as, in direct sunlight, inside a closed car, next to a heater, etc... This action could permanently damage the internal parts of your Palmcorder.
- **AVOID SUDDEN CHANGES IN TEMPERATURE** ... If the unit is suddenly moved from a cold place to a warm place, moisture may form on the tape and inside the unit.
- **DO NOT LEAVE YOUR PALMCORDER OR THE POWER SUPPLY TURNED ON WHEN NOT IN USE.**
- **STORAGE OF YOUR PALMCORDER** ... Store and handle your Palmcorder in a manner that will not subject it to unnecessary movement (avoid shaking and striking). Your Palmcorder contains a sensitive pick-up device which could be damaged by improper handling or storage.

CARE

- **TO CLEAN YOUR PALMCORDER** ... Do not use strong or abrasive detergents when cleaning your Palmcorder body.
- **TO PROTECT THE LENS** ... Do not touch the surface of the lens with your hand. Use a commercial Palmcorder lens solution and lens paper when cleaning the lens. Improper cleaning can scratch the lens coating.
- **TO PROTECT THE FINISH OF YOUR PALMCORDER** ... Before handling your Palmcorder, make sure your hands and face are free from any chemical products, such as suntan lotion, as it may damage the finish.

Contents

Before Use

Before Using	6
Standard Accessories	6
Quick Guide	7
To watch the Playback Picture	7
Controls and Components	8
Remote Controller	10
Power Supply	12
Charging Time and Available Recording Time	12
Lens Cap and Grip Belt	13
Attaching the Shoulder Strap	13
Inserting a Cassette	13
Turning on/off the Palmcorder and selecting Modes	14
Using the Viewfinder	14
Using the LCD Monitor	14
Using the Menu Screen	15
List of Menus	16
Setting Date and Time	19
Internal Lithium Battery Recharge	19
LP Mode	19
Audio Recording Mode	19

CAMERA MODE

Recording	20
PhotoShot Recording on the DV Cassette	21
Zoom In/Out Functions	21
Digital Zoom Function	22
Digital Electronic Image Stabilizer Function	22
Fade In/Out Functions	22
Backlight Compensation Function	23
Recording in Special Situations	23
Manual Shutter Speed Adjustment	24
Manual Iris Adjustment (F Number)	24
Manual Focus Adjustment	24
Recording in Natural Colors	25
Adjusting White Balance Manually	25
Digital Effect Functions	26

VCR MODE

Playing Back	28
Finding a Scene You Want to Play Back	28
Slow Motion Playback	29
Still Playback/Still Advance Playback	29
Finding the End of Recording	29
Index Search Functions	30
Playback Zoom Function	31
Playback Digital Effect Functions	31
Playing Back on Your TV	33
Audio Dubbing	33

Special Features

Using a Memory Card	34
Recording on the Memory Card	34
Playing Back Pictures on the Memory Card	35
Copying pictures on a Memory Card to a Cassette	36
Creating a Title	37
Inserting a Title	37
Protecting the Pictures on a Memory Card from Accidental Erasure (File Lock)	38
Deleting the pictures recorded on a Memory Card	38
Formatting a Memory Card	39
DPOF Setting	39
Copying your DV Cassette to an S-VHS or VHS Cassette (Dubbing)	40
Copying an S-VHS or VHS Cassette to your DV Cassette	40
Using your Palmcorder with Digital Video Equipment (Dubbing)	41
PC Connection with DV Interface Cable	41
Using the Supplied Software with a Computer	42
Software Installation (Windows® 95/98/Me, Windows® 2000)	42
PHOTOVU LINK	43
ArcSoft Software	44
Using the Supplied USB Reader/Writer for SD Memory Card	45

Others

Indications	48
Warning/Alarm Indications	50
Notes&Precautions	51
Caution for Use	54
Explanation of Terms	57
Specifications	58
Palmcorder Accessory System	59
Palmcorder Accessory order Form	60
Before Requesting Service (Problems and Solutions)	61
Request for Service Notice	63
Limited Warranty	64
Servicenter List	65
Software License Agreement	66
Index	67
Spanish Quick Use Guide/ Guía española para el uso rápido	68

Before Use

CAMERA

VCR

Special Features

Others

Before Using

These operating Instructions are designed for use with models PV-DV901 and PV-DV851. Pictures may be slightly different from the original.

• Features may vary, so please read carefully.



PV-DAC11B

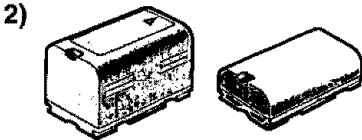

PV-DBP9A (PV-DV901) PV-DBP8A (PV-DV851)



N2QAEC000003 CR2025



VFC3508



K2KC4CB00002



VFA0352



LSFT0259 (PV-DV901)
LSFT0261 (PV-DV851)



LSFT0257

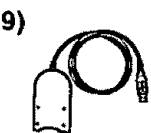

BN-SDCAAE

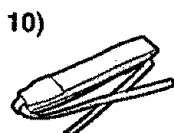

VFC3508

Model Number	PV-DV851	PV-DV901
LCD Monitor	2.5 inch (63.5 mm) Liquid Crystal Display	3.0 inch (76.2 mm) Liquid Crystal Display
Supplied Battery	800 mAh (PV-DBP8A)	1600 mAh (PV-DBP9A)
Supplied SD Memory Card	8 MB (LSFT0261)	16 MB (LSFT0259)

Standard Accessories

Illustrated on the left are accessories packaged with the Palmcorder.

1) AC Adaptor, DC Cable and AC Cable (→ 12)

• Supplies power to the Palmcorder.

CAUTION:

This unit will operate on 110/120/220/240V AC. An AC plug adaptor may be required for voltages other than 120V AC. Please contact either a local or foreign electrical parts distributor for assistance in selecting an alternate AC plug. We recommend using the accessory power plug adaptor (VJSS0070) in an area which has special AC outlets.

2) Battery Pack (→ 12)

• Supplies power to the Palmcorder.

3) Remote Controller and Button-Type Battery (→ 10, 11)

4) Lens Cap and Lens Cap Cord (→ 13)

5) A/V Cable (→ 33, 40)

6) PC Connection Cable (→ 42)

7) SD Memory Card (→ 47)

8) CD-ROM :

Driver Soft for USB Reader/Writer for SD Memory Card
(Windows® 98/Me, Windows®2000) (→ 45, 46)

PHOTOVU LINK (Windows® 95/98/Me, Windows®2000)
(→ 42, 43)

ArcSoft Software (Windows® 95/98/Me, Windows®2000) (→ 42, 44)

• Microsoft and Windows are registered trademarks of Microsoft in the United States and other countries. Intel Pentium is a registered trademark. i.LINK and "i" are trademarks.

SD is a trademark.

9) USB Reader/Writer for SD Memory Card (→ 45, 46)

10) Shoulder Strap (→ 13)

Quick Guide

1

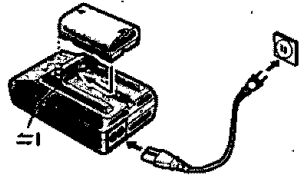

1 Charge the Battery. (→ 12)

- Connect the AC Cable to the AC Adaptor and AC Jack.
- Attach the Battery to the AC Adaptor. (This will start charging.)
- When the Charge Lamp [CHARGE] goes off, the Battery is fully charged.
- Since the Battery will not be charged when the DC Cable is connected to the AC Adaptor, disconnect it.

2

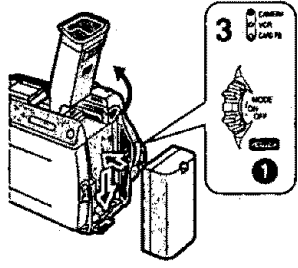

2 Attach the Charged Battery to the Palmcorder. (→ 12)

- Attach the battery after tilting the Viewfinder upward.

3

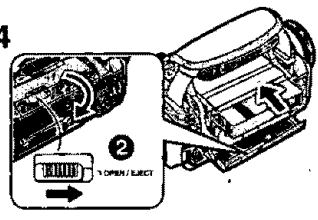

3 Turn the Palmcorder on. (→ 14)

- Slide the 1 Switch to [ON]. (The [CAMERA] Lamp lights up.)

4

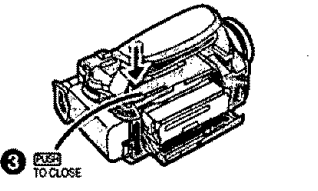

4 Insert the Cassette. (→ 13)

- Slide the 2 lever to the right and pull down to open the Cassette compartment cover.
- Insert the Cassette.
- Press the [PUSH/TO CLOSE] 3 to load the Cassette.
- Close the lower compartment Cover.

5

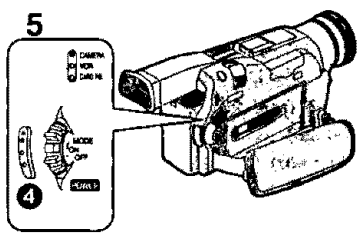

5 Start recording. (→ 20)

- Press the 4 Button. (Recording starts.)
- Press the 4 Button again to pause the recording.

6

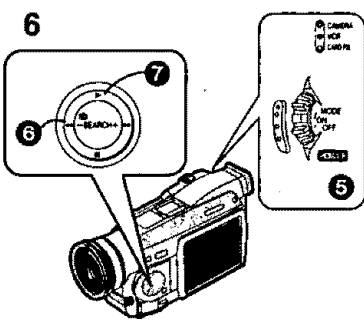

To watch the Playback Picture

6 Switch to the VCR Mode, rewind the tape, and play the tape back. (→ 28)

- Slide the 5 Switch. (The [VCR] Lamp lights up.)
- Press the 6 Button.
- Press the 7 Button. (This will start playback.)

7

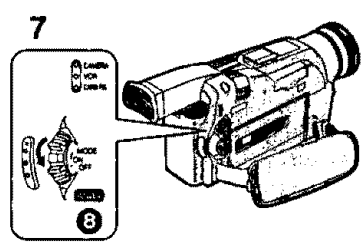

7 Turn the Palmcorder off. (→ 14)

- Set the 8 Switch to [OFF].

Controls and Components

1) Accessory Shoe

- Accessories, such as a stereo microphone (not supplied), are attached here.

2) Shoe Cover

3) Fade Button [FADE] (→ 22)

4) Backlight Button [BACK LIGHT] (→ 23)

5) Still Button [CAMERA STILL] (→ 21)

6) LCD Monitor Open Button [PUSH OPEN] (→ 14)

7) LCD Monitor (→ 14)

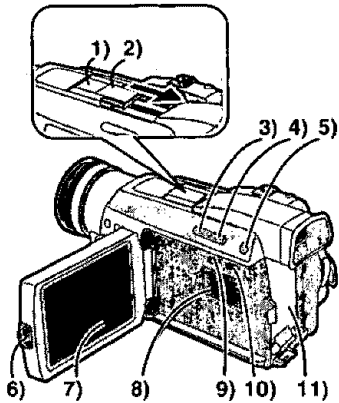

-
- Due to limitations in LCD production technology, there may be some tiny bright or dark spots on the LCD Monitor screen. However, this is not a malfunction and does not affect the recorded picture.
-

8) Speaker

9) Title Button [TITLE] (→ 37)

10) Multi-Picture Button [MULTI] (→ 27, 32, 36, 37)

- Picture-in-Picture Button [P-IN-P] (→ 27)

11) Battery Holder (→ 12)

12) Mode Selector Switch [AUTO/MANUAL] (→ 20, 23, 24, 25)

13) Focus Button [FOCUS] (→ 24)

14) Lens Hood

- Always keep the Lens Hood attached to the Palmcorder so as to shut out unnecessary light.

15) Lens

16) Tally Lamp (→ 20)

17) White Balance Sensor (→ 57)

- Remote Control Sensor (→ 11)

18) Microphone (built-in, stereo)

19) Play Button [▶] (→ 28, 35)

20) Reverse Search Button [-SEARCH] (→ 20)

- Rewind/Review Button [◀◀] (→ 28)

- Recording Check Button [Ⓢ] (→ 20)

21) Stop Button [■] (→ 28)

22) Forward Search Button [SEARCH+] (→ 20)

- Fast Forward/Cue Button [▶▶] (→ 28)

23) Pause Button [II] (→ 29)

24) DV Input/Output Terminal (i.LINK) [i] (→ 41)

- Connect this to the digital video equipment.

25) Menu Button [MENU] (→ 15)

26) Multi-Function Dial [PUSH] (→ 15, 19, 24, 25, 28, 29)

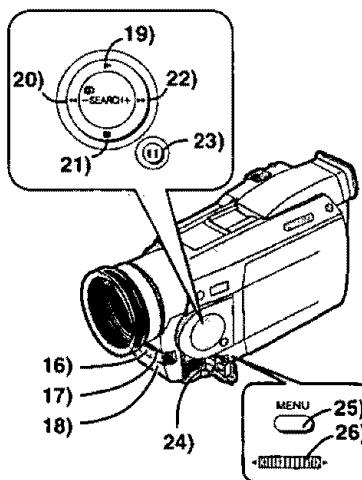
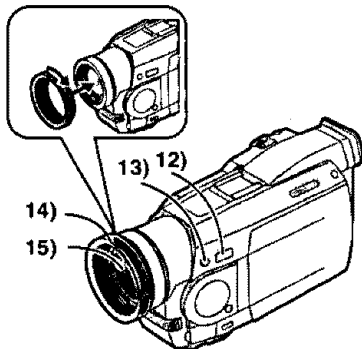

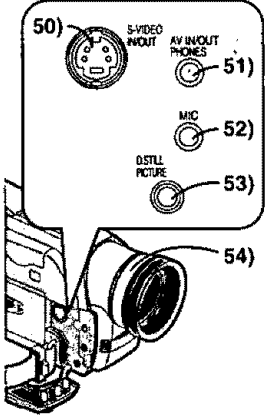
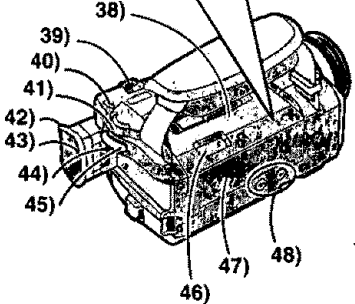
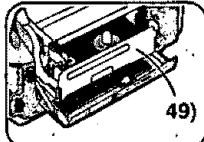
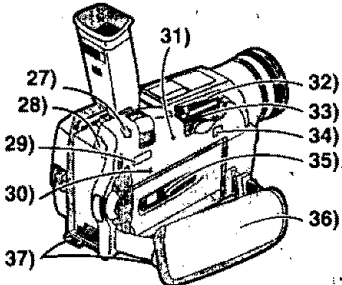

- 27) Photoshot Button [PHOTO SHOT] (→ 21, 34)
 28) Battery Eject Button [BATT. EJECT] (→ 12)
 29) Tape/Card Photoshot Selector [TAPE/CARD] (→ 34)
 30) Reset Button [RESET] (→ 61)
 31) Card Access Lamp [ACCESS] (→ 34)
 32) Card Slot Cover (→ 34)
 33) Card Slot (→ 34)
 34) Card Slot Cover Open Lever [OPEN] (→ 34)
 35) Cassette Compartment Window (→ 13)
 36) Grip Belt (→ 13)
 37) Shoulder Strap Holders (→ 13)
 38) Upper Cassette Compartment Cover (→ 13)
 39) Zoom Lever [W/T] (→ 21, 22)
 40) Operation Mode Lamps [CAMERA/VCR/CARD P.B.] (→ 14, 20, 28, 35)
 41) Power Off/On Mode Selector Switch [OFF/ON/MODE] (→ 14)
 42) Eyecup
 43) Viewfinder (→ 14)
-
- Due to limitations in LCD production technology, there may be some tiny bright or dark spots on the Viewfinder screen. However, this is not a malfunction and does not affect the recorded picture.
-
- 44) Eyepiece Corrector Knob (→ 14)
 45) Recording Start/Stop Button (→ 20)
 46) Cassette Eject Lever [OPEN/EJECT] (→ 13)
 47) Lower Cassette Compartment Cover (→ 13)
 48) Tripod Receptacle (Tripod Mounting Hole)
 • Used for mounting the Palmcorder on an optional tripod.
 49) Cassette Holder (→ 13)
 50) S-Video Input/Output Jack [S-VIDEO IN/OUT] (→ 33, 40)
 51) Audio-Video Input/Output Jack [AV IN/OUT] (→ 33, 40)
 Headphone Jack [PHONES] (→ 53)
 • When a cable is connected to this jack, the built-in speaker of the Palmcorder is disabled.
 52) Microphone Jack [MIC] (→ 33; 53)
 • Connect with an external microphone or audio equipment. (When this jack is in use, the built-in microphone does not function.)
 53) Digital Still Picture Terminal [D.STILL PICTURE] (→ 42)
 54) Focus Ring (→ 24)

Remote Controller

Using the wireless remote controller that is supplied with the Palmcorder, most of the Palmcorder functions can be operated from a distance.

Remote Controller Buttons

- 1) Date and Time Button [DATE/TIME] (→ 50)
- 2) Indication Output Button [OSD] (→ 33)
- 3) Counter Reset Button [RESET] (→ 57)
- 4) Indication Shift Button [COUNTER] (→ 50)
- 5) Multi-Picture/Picture-in-Picture Button [MULTI/P-IN-P] (→ 27, 32, 36, 37)
- 6) Recording Button [REC] (→ 40, 41)
- 7) Audio Dubbing Button [A.DUB] (→ 33)
- 8) Upward Direction Button [▲] (for Playback Zoom Function) (→ 31)
- 9) Left/Right Direction Button [◀, ▶] (for Playback Zoom Function) (→ 31)
- 10) Downward Direction Button [▼] (for Playback Zoom Function) (→ 31)
- 11) Slow Motion/Still Advance Button [◀, ▶] (◀: reverse direction, ▶: normal direction) (→ 29)
- 12) Index Search Button [◀◀, ▶▶] (◀◀: reverse direction, ▶▶: normal direction) (→ 30)
- 13) Selection Button [SELECT] (→ 31)
- 14) Store Button [STORE] (→ 31)
- 15) Off/On Button [OFF/ON] (→ 31)
- 16) Zoom/Volume Button [ZOOM/VOL] (→ 21, 22, 28, 31)
- 17) Variable Speed Search Button [VAR.SEARCH] (→ 28)
- 18) Playback Zoom Button [P.B.ZOOM] (→ 31)
- 19) Speed Selection Button [A, V] (for variable speed search function) (→ 28)

The following buttons function in the same manner as the corresponding buttons on the Palmcorder.

- 20) Photoshot Button [PHOTOSHOT] (→ 21, 34)
- 21) Recording Start/Stop Button [START/STOP] (→ 20)
- 22) Title Button [TITLE] (→ 37)
- 23) Menu Button [MENU] (→ 15)
- 24) Item set Button [SET] (→ 15)
- 25) Item select Button [ITEM] (→ 15)
- 26) Fast-forward/Cue Button [▶▶] (→ 28)
- 27) Play Button [▶] (→ 28, 35)
- 28) Rewind/Review Button [◀◀] (→ 28)
- 29) Pause Button [||] (→ 29, 35)
- 30) Stop Button [■] (→ 28, 35)

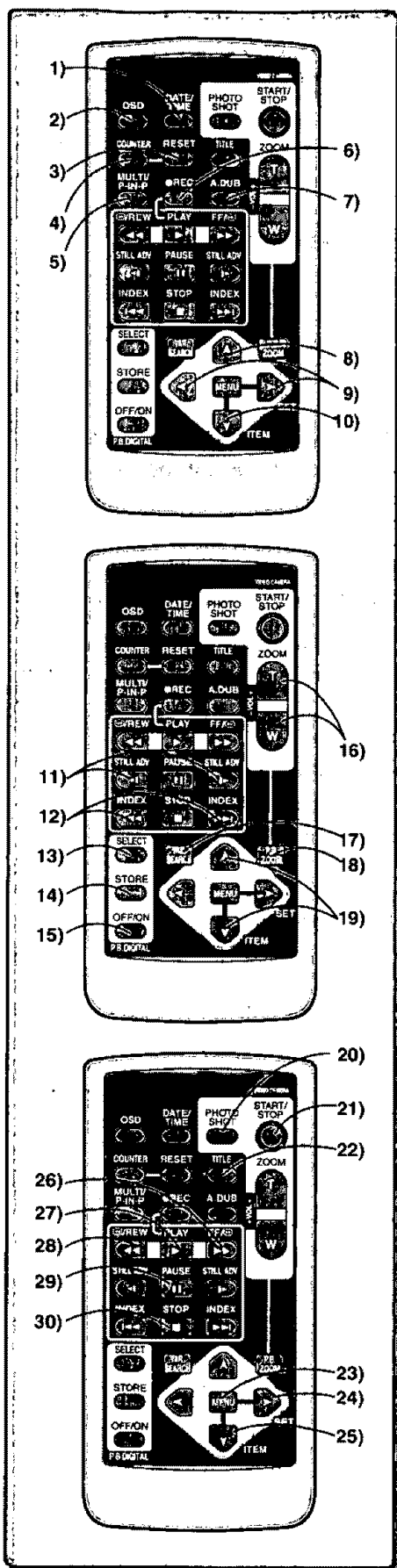

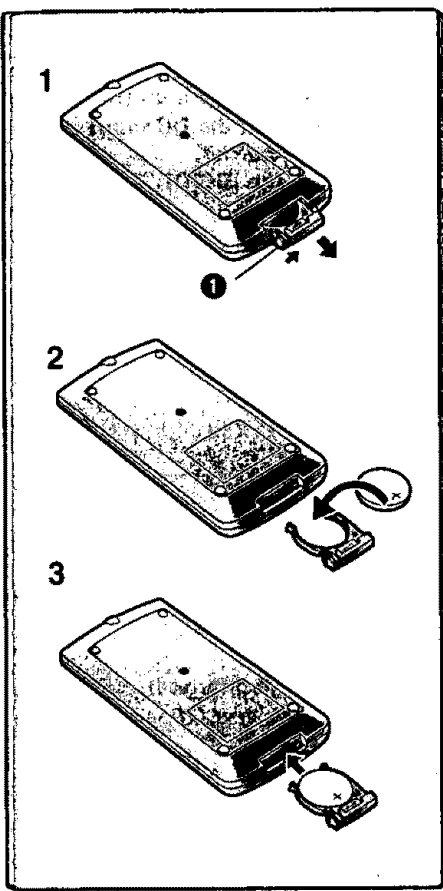

■ Inserting a Button-type Battery

Before using the remote controller, insert the supplied button-type battery.

- 1 While pressing the Stopper ❶, pull out the Battery Holder.
- 2 Insert the button-type battery with the imprint (+) facing upward.
- 3 Insert the Battery Holder into the Remote Controller.

- When the button-type battery becomes weak, replace it with a new CR2025 battery. (A battery is normally expected to last about one year. However, it depends on operation frequency.)
- Make sure to match the poles properly when inserting the battery.

Warning

Danger of explosion if battery is incorrectly replaced.
 Replace only with the same or equivalent type recommended by the equipment manufacturer. Discard used batteries according to manufacturer's instructions.
Risk of fire, explosion and burns. Do not recharge, disassemble, heat above 212° F (100° C) or incinerate. Keep the Button-Type battery out of the reach of children. Never put Button-Type battery in mouth. If swallowed call your doctor.

Replace battery with Panasonic PART NO. VSBW0004 (CR2025) only. Use of another battery may present a risk of fire or explosion. Caution-battery may explode if mistreated. Dispose of used battery promptly. Keep away from children. Do not recharge, disassemble or dispose of in fire.

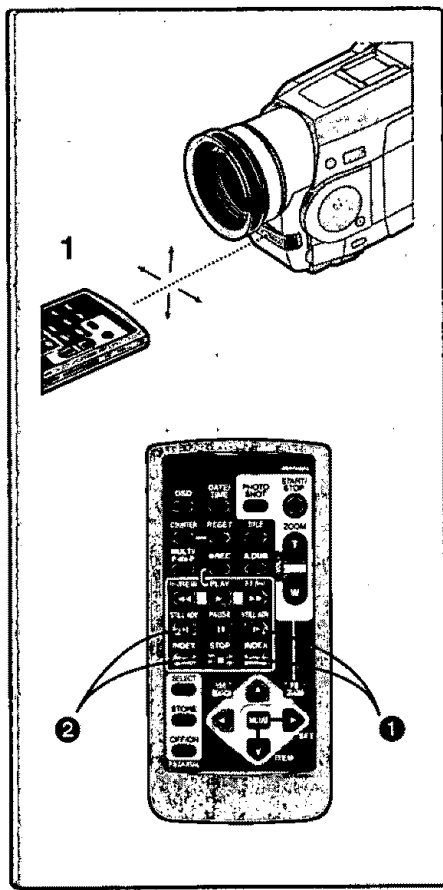

■ Using the Remote Controller

- 1 Direct the Remote Controller to the Remote Control Sensor on the Palmcorder and press the desired button.
 - Distance from the Palmcorder: Within Approximately 15 feet (5 meters)
 - Angle: Approximately 15 degrees in the vertical and horizontal directions from the central axis

- The above operating ranges are for indoor use. Outdoors or under strong light, the equipment may not operate properly even within the above ranges.
- Within 3 feet (1 meter) range, you can also use the Remote Controller on the side (the LCD Monitor side) of the Palmcorder.

Selecting Remote Controller Modes

When 2 Palmcorders are used simultaneously, they can be operated individually by selecting different Remote Controller Modes.
 • If the Remote Controller Mode on the Palmcorder and Remote Controller do not match, [REMOTE] is displayed.

Setting on the Palmcorder:

Set [REMOTE] on the [OTHER FUNCTIONS] Sub-Menu to the desired Remote Controller Mode.

Setting on the Remote Controller:

- [VCR1]: Press the [▶] Button and [■] Button simultaneously. ❶
- [VCR2]: Press the [◀] Button and [■] Button simultaneously. ❷
- When the battery in the Remote Controller is replaced, the Mode is automatically reset to [VCR1] Mode.

Power Supply

■ Using the AC Adaptor

- 1 Slide the Viewfinder backward and then tilt it upward.
- 2 Insert the battery-shaped connector of the DC Input Lead into the Battery Holder on the Palmcorder.
- 3 Connect the DC connector plug to the [DC OUT] Jack on the AC Adaptor.
- 4 Connect the AC Adaptor and AC Cable.

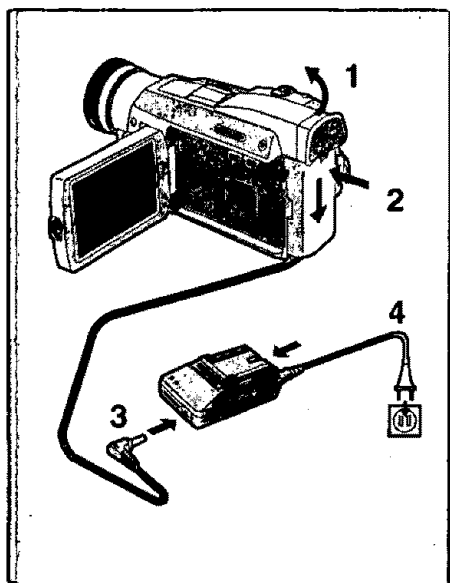

■ Using the Battery

- Before use, fully charge the battery.

1 Attach the Battery to AC Adaptor and charge it.

- Since the Battery will not be charged when the DC Cable is connected to the AC Adaptor, disconnect it.
- The [CHARGE] Lamp lights up, and charging starts.
- When the [CHARGE] Lamp goes off, charging is completed.

2 Attach the charged Battery to the Palmcorder.

Disconnecting the Power Source

Set the [OFF/ON/MODE] Switch to [OFF] and, while pressing the [BATT. EJECT] Button ①, slide the Battery or DC Cable upward to disconnect it.

- For other notes, see page 51.

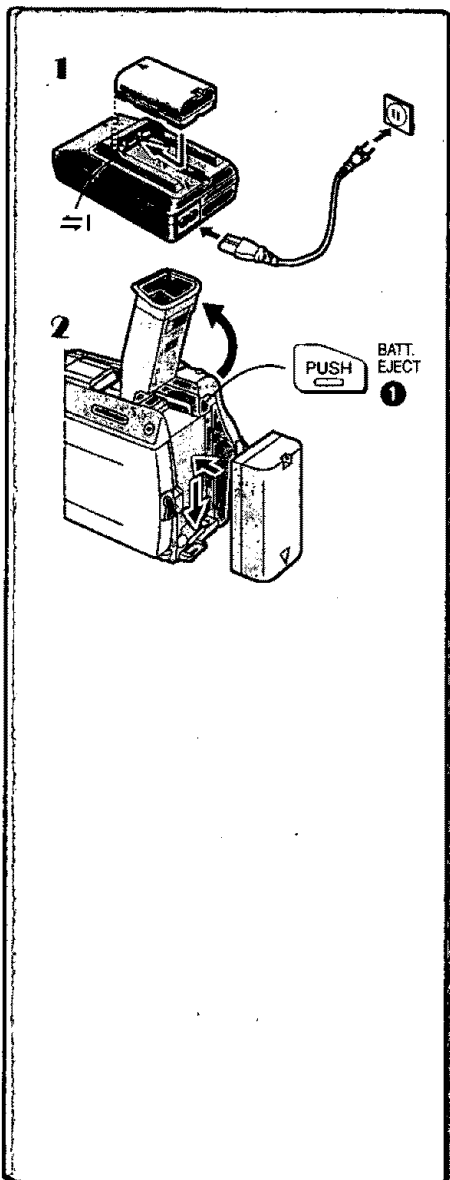

Charging Time and Available Recording Time

Ⓐ Charging Time

Ⓑ Maximum Continuous Recording Time





- "1 h 20 min." indicates 1 hour and 20 minutes.

- Battery PV-DBP9A is supplied (PV-DV901).

- Battery PV-DBP8A is supplied (PV-DV851).

- The hours shown in the table below are approximate hours. The numeric characters in parentheses indicate the recording time when the LCD monitor is used. In actual use, the available recording time may be shorter in some cases.

- The hours shown in the table below are for continuous recording at a temperature of 68 °F (20 °C) and humidity of 60 %. If the Battery is charged at a higher or lower temperature, the charging time may become longer.

CGR-D08A/1B PV-DBP8A 	Ⓐ	1 h.
	Ⓑ	1 h 20 min. (1 h 5 min.)
CGR-D16A/1B PV-DBP9A 	Ⓐ	2 h.
	Ⓑ	2 h 50 min. (2 h 15 min.)
CGP-D28A/1B 	Ⓐ	3 h 15 min.
	Ⓑ	4 h 50 min. (3 h 55 min.)
CGR-D53A/1K CGR-DB15A/1B 	Ⓐ	5 h 20 min.
	Ⓑ	9 h 10 min. (7 h 40 min.)

Lens Cap and Grip Belt

To protect the Lens surface, attach the Lens Cap. Adjust the length of the Grip Belt to the size of your hand.

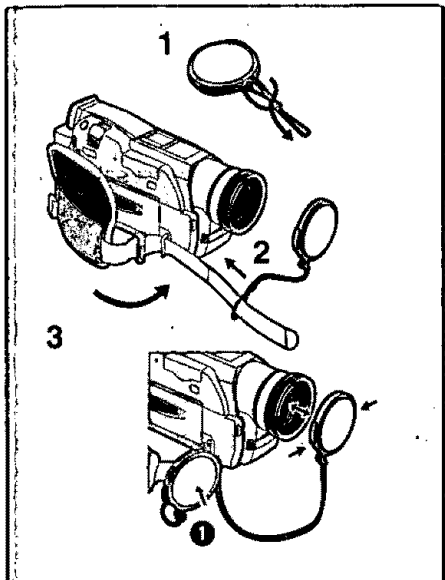

- 1 Attach the longer loop of the Lens Cap Cord to the Lens Cap.
 - 2 Attach the shorter loop to the grip belt.
 - 3 Put your hand through the Grip Belt and adjust the length.
- The removed Lens Cap can be hooked onto the grip belt ❶. (When you are not recording, be sure to keep the Lens Cap attached to the Lens for protection.)

Attaching the Shoulder Strap

We recommend that you attach the Shoulder Strap before going out of doors to record so as to avoid dropping the Palmcorder.

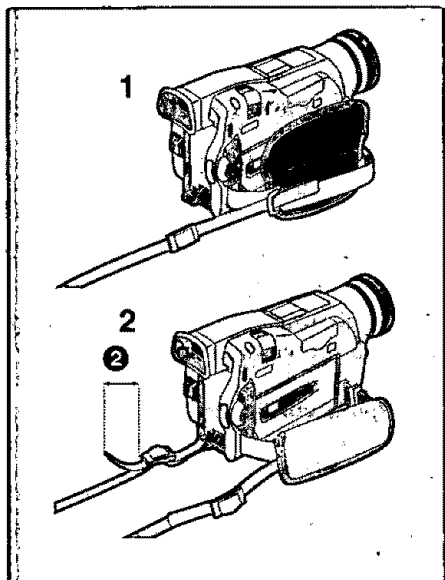

- 1 Pass the tip of the Shoulder Strap through the Shoulder Strap Holder on the Palmcorder and pull the Shoulder Strap.
 - 2 Fold the tip of the Shoulder Strap, pass it through the Shoulder Strap Length Adjuster, and pull it.
- Pull it out more than 1 inch (2 cm) ❷ from the Shoulder Strap Length Adjuster so that it cannot slip off.

Inserting a Cassette

When power is supplied to the Palmcorder, the cassette can be taken out without turning the Palmcorder on.

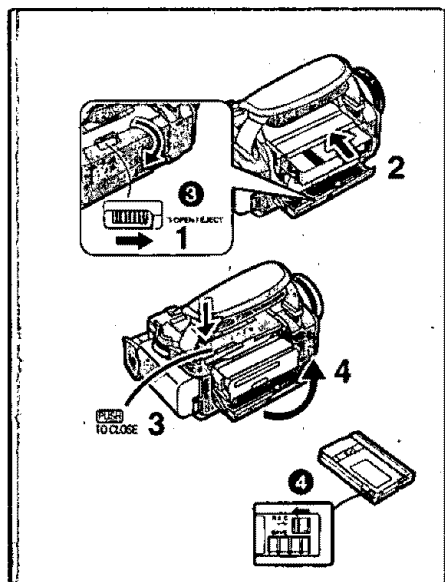

- 1 Slide the [OPEN/EJECT] Lever ❸ to the right and pull down to open the Cassette Compartment.
- 2 Insert a Cassette.
- 3 Close the Cassette Compartment and lock the Cassette Compartment by pressing the [PUSH TO CLOSE] mark.
- 4 Close the Lower Cassette Compartment Cover.

• For other notes, see page 51.

Accidental Erasure Prevention

Opening the accidental erasure prevention slider ❹ on the cassette (by sliding it in the [SAVE] arrow direction) prevents recording. To enable recording, close the accidental erasure protection slider (by sliding it in the [REC] arrow direction.)

Turning on/off the Palmcorder and selecting Modes

Turn on the power first and then select Modes.

How to Turn on the Power

- 1 Set the [OFF/ON/MODE] Switch to [ON] while pressing the center Button ①.

- The [CAMERA] Lamp lights up.

How to Switch Modes

- 2 Slide the [OFF/ON/MODE] Switch.

- With each slide of the Switch, the Mode switches in the order of Camera Mode, VCR Mode, and Card Playback Mode.

- The appropriate Mode Lamp lights up.

How to Turn off the Power

- 3 Set the [OFF/ON/MODE] Switch to [OFF] while pressing the center Button.

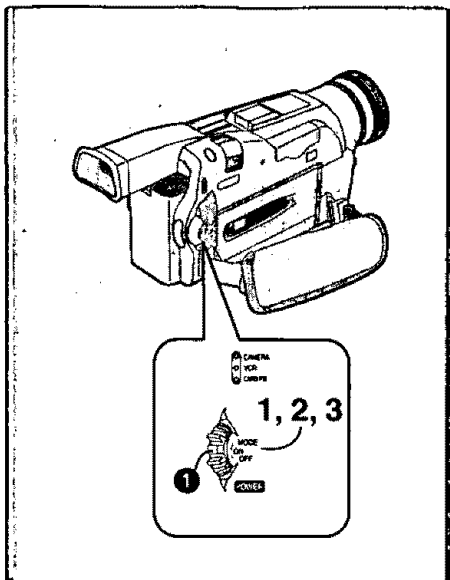

Using the Viewfinder

Before using the Viewfinder, adjust the field of view so that the displays inside the viewfinder become clear and easy to read.

- 1 Slide the Viewfinder backward and then tilt it upward.

- The Viewfinder angle is adjusted upward.

- 2 Adjust by sliding the Eyepiece Corrector Knob ①.

Using the LCD Monitor

With the LCD Monitor open, you can also record the picture while watching it.

- 1 Turn the [OFF/ON/MODE] Switch to [ON].

- 2 Press the [PUSH OPEN] Button and, at the same time, bring out the LCD Monitor about 90° in the direction of the arrow.

- The Viewfinder goes off.

- 3 Adjust the LCD Monitor angle according to the desired recording angle.

- The LCD Monitor can rotate a maximum of 180° ② from the vertical position to the upward direction and a maximum of 90° ③ to the downward direction. Forcefully rotating the LCD monitor beyond these ranges will damage the Palmcorder.

Closing the LCD monitor

Push the LCD Monitor until the [PUSH OPEN] Button is securely locked.

Adjusting Brightness and Color Level

When [LCD/EVF SET] on the [DISPLAY SETUP] Sub-menu is set to [YES], the following items are displayed.

LCD Brightness [LCD BRIGHTNESS]

Adjusts the brightness of the image on the LCD screen.

LCD Color Level [LCD COLOR]

Adjusts the color saturation of the image on the LCD screen.

Brightness of the Viewfinder [EVF BRIGHTNESS]

Adjust the brightness of the image in the Viewfinder.

- 1 Press the [PUSH] Dial and select the item you want to adjust.
- 2 Rotate the [PUSH] Dial and increase or decrease the number of the vertical bars on the Bar Indication.

- The Bar Indication has 8 steps. A larger number of vertical bars indicates stronger brightness or color saturation.

Increasing the Brightness of the Entire LCD Monitor

Set the [LCD MODE] on the [DISPLAY SETUP] Sub-Menu to [BRIGHT].

- These adjustments do not affect the recorded images.

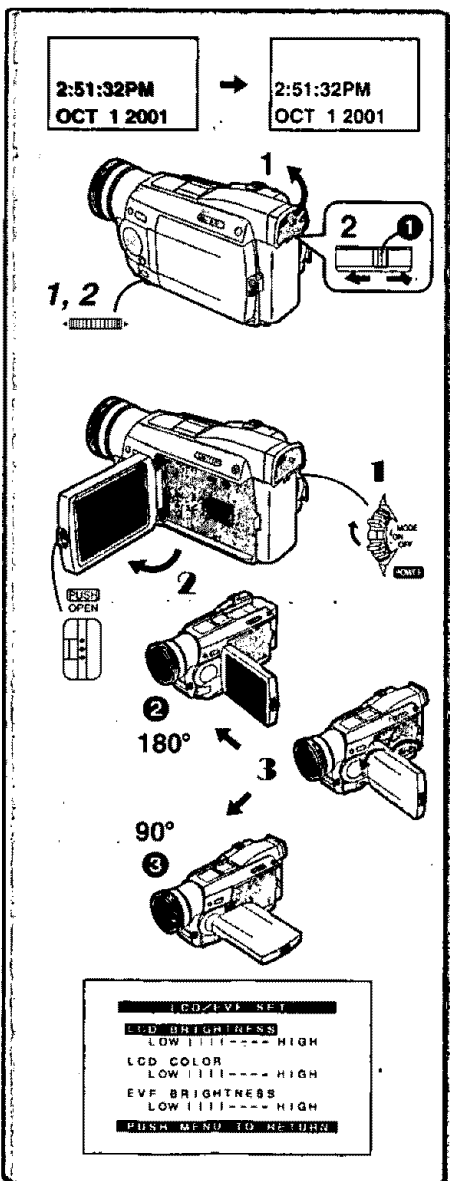

Using the Menu Screen

To facilitate the selection of a desired function or setting, this Palmcorder displays various function settings on menus.

1 Press the [MENU] Button.

- When the [CAMERA] Lamp is on, the Camera Function Menu is displayed. ①
- When the [VCR] Lamp is on, the VCR Function Menu is displayed. ②
- When the [CARD P.B.] Lamp is on, the Card Function Menu is displayed. ③

2 Rotate the [PUSH] Dial to select a desired Sub-Menu.

- Rotate the [PUSH] dial to display the items highlighted.

3 Press the [PUSH] Dial to display the selected Sub-Menu.

4 Rotate the [PUSH] Dial to select the item to be set.

5 Press the [PUSH] Dial to set the selected item to a desired Mode.

- Each press of the cursor [▶] brings up a subsequent Mode. Menu items that cannot be used in combination with the selected item are displayed in dark blue.

- While a Menu is displayed, you cannot record or play back. Menus can be displayed during playback but not during recording.

- The above operations can be carried out using the Remote Controller. (→ 10)

- To display the Menu, press the [MENU] Button ④ on the Remote Controller.

- To select items on the Menu, press the [ITEM] Button ⑤ on the Remote Controller.

- To set the mode for the selected items, press the [SET] Button ⑥ on the Remote Controller.

To Exit the Menu Screen

Press the [MENU] Button again.

About the Menu Mode Setting

The setting selected on the Menu will be retained even when the Palmcorder is turned off. However, if the Battery or AC Adaptor is disconnected before Turning the Palmcorder off, the selected setting may not be retained.

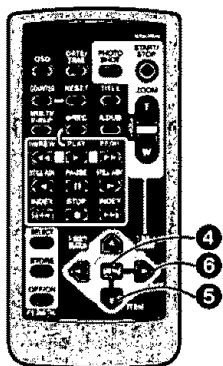
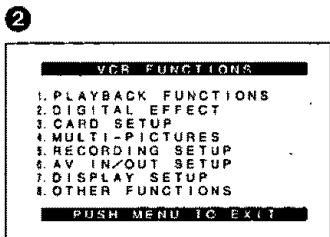
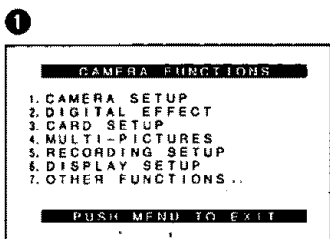
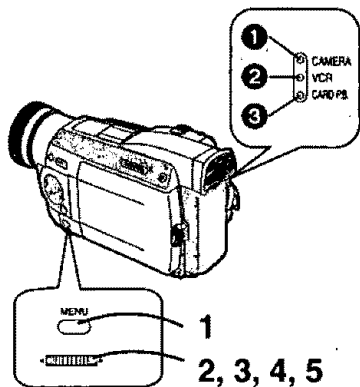

List of Menus

The illustrations of the Menus are for explanation purposes only, and they are different from the actual Menus.

Camera Mode Main-Menu [CAMERA FUNCTIONS]

- 1) **CAMERA SETUP**
- 2) PROG. AE ▶ OFF ON
- 3) PROGRESSIVE-AUTO ON OFF
- 4) EIS ▶ OFF ON
- 5) D. ZOOM ▶ OFF 25x 100x
- 6) RETURN ▶ ---- YES
PUSH MENU TO EXIT
- 7) **DIGITAL EFFECT**
- 8) EFFECT1 ▶ OFF MULTI P-IN-P
WIPE MIX STROBE
GAIN-UP TRAIL
MOSAIC MIRROR
- 9) EFFECT2 ▶ OFF NEGA SEPIA
MONO SOLARI
- 10) RETURN ▶ ---- YES
PUSH MENU TO EXIT
- 11) **CARD SETUP**
- 12) PICTURE SIZE ▶ 1200x900 840x480
- 13) REC MODE ▶ FINE NORMAL ECONOMY
- 14) CREATE TITLE ▶ ---- YES
- 15) RETURN ▶ ---- YES
PUSH MENU TO EXIT
- 16) **MULTI-PICTURES**
- 17) SCAN MODE ▶ STROBE MANUAL
- 18) SPEED ▶ FAST NORMAL SLOW
- 19) SWING ▶ OFF ON
- 20) P-IN-P ▶ 1 2 3 4
- 21) RETURN ▶ ---- YES
PUSH MENU TO EXIT
- 22) **RECORDING SETUP**
- 23) REC-SPEED ▶ SP LP
- 24) AUDIO-REC ▶ 12MIN 16MIN
- 25) INDEX ▶ 2 HOUR DAY
- 26) WIND-CUT ▶ OFF ON
- 27) RETURN ▶ ---- YES
PUSH MENU TO EXIT
- 28) **DISPLAY SETUP**
- 29) DATE/TIME ▶ OFF D/T DATE
- 30) C. DISPLAY ▶ LINEAR MEMORY
T. CODE
- 31) C. RESET ▶ ---- YES
- 32) DISPLAY ▶ ALL PARTIAL OFF
- 33) LCD MODE ▶ NORMAL BRIGHT
- 34) LCD/EVF SET ▶ ---- YES
- 35) RETURN ▶ ---- YES
PUSH MENU TO EXIT
- 36) **OTHER FUNCTIONS**
- 37) REMOTE ▶ VCR1 VCR2 OFF
- 38) TALLY LED ▶ OFF ON
- 39) BEEP ▶ OFF ON
- 40) SHUTTER ▶ OFF ON
- 41) CLOCK-SET ▶ ---- YES
- 42) SELF-REC ▶ NORMAL MIRROR
- 43) RETURN ▶ ---- YES
PUSH MENU TO EXIT

[CAMERA SETUP] Sub-Menu

- 1) Auto Exposure Mode [PROG.AE] (→ 23)
- 2) Progressive Photoshot Mode [PROGRESSIVE] (→ 21)
- 3) Digital Electronic Image Stabilizer [EIS] (→ 22)
- 4) Digital Zoom [D.ZOOM] (→ 22)
- 5) Returning to the Main-Menu [RETURN]

[DIGITAL EFFECT] Sub-Menu

- 6) Digital Effects 1 [EFFECT1] (→ 26)
- 7) Digital Effects 2 [EFFECT2] (→ 26)

[CARD SETUP] Sub-Menu

- 8) Picture Size [PICTURE SIZE] (→ 34)
- 9) Picture Quality [REC MODE] (→ 34)
- 10) Title Creation [CREATE TITLE] (→ 37)

[MULTI-PICTURES] Sub-Menu

- 11) Multi-Picture Mode [SCAN MODE] (→ 27)
- 12) Strobe Multi-Picture Speed [SPEED] (→ 27)
- 13) Swing Mode [SWING] (→ 27)
- 14) Position of Small Picture Inside Normal Picture [P-IN-P] (→ 27)

[RECORDING SETUP] Sub-Menu

- 15) Recording Speed Mode [REC-SPEED] (→ 19)
- 16) Audio Recording Mode [AUDIO-REC] (→ 19, 33)
- 17) Index Mode [INDEX] (→ 30)
- 18) Wind Noise Reduction [WIND-CUT]
 - If this function is set to [ON], the sound of wind hitting the microphone can be reduced for recording.

[DISPLAY SETUP] Sub-Menu

- 19) Date and Time Indication [DATE/TIME] (→ 50)
- 20) Counter Display Mode [C.DISPLAY] (→ 50).
- 21) Counter Reset [C.RESET] (→ 57)
 - Set the counter value to zero. However, it cannot reset the Time Code.
- 22) Display Mode [DISPLAY] (→ 50)
- 23) LCD Brightness [LCD MODE] (→ 14)
- 24) LCD and Viewfinder Adjustment [LCD/EVF SET] (→ 14)

[OTHER FUNCTIONS] Sub-Menu

- 25) Remote Controller Mode [REMOTE] (→ 11)
- 26) Recording Lamp [TALLY LED] (→ 20)
- 27) Beep Sound [BEEP]
 - 1 Beep
 - When you start recording
 - When you switch the [OFF/ON/MODE] Switch from [OFF] to [ON]
 - 2 Beeps
 - When you pause recording
 - 10 Beeps
 - If you perform a wrong operation before or during recording
- 28) Shutter Effect [SHUTTER] (→ 21)
- 29) Date and Time Setting [CLOCK-SET] (→ 19)
- 30) Self-Recording [SELF-REC] (→ 20)

VCR Mode Main-Menu [VCR FUNCTIONS]

[PLAYBACK FUNCTIONS] Sub-Menu

- 1) Blank Search [BLANK SEARCH] (→ 29)
- 2) Recording to Card [RECORD TO CARD] (→ 35)
- 3) Index Search Mode [INDEX] (→ 30)
- 4) Audio Output Mode [AUDIO] (→ 33)
- 5) Audio Selector [AUDIO OUT] (→ 53)
- 6) Returning to the Main-Menu [RETURN]

[DIGITAL EFFECT] Sub-Menu

- 7) Digital Effect On/Off [EFFECT] (→ 31, 32)
- 8) Digital Effect Selection [EFFECT SELECT] (→ 31, 32)

[CARD SETUP] Sub-Menu

- 9) Picture Quality [REC MODE] (→ 34)
- 10) Title Creation [CREATE TITLE] (→ 37)

[MULTI-PICTURES] Sub-Menu

- 11) Multi-Picture Mode [SCAN MODE] (→ 32)
- 12) Strobe Multi-Picture Speed [SPEED] (→ 32)
- 13) Swing Mode [SWING] (→ 32)

[RECORDING SETUP] Sub-Menu

- 14) Recording Speed Mode [REC-SPEED] (→ 19, 40, 41)
- 15) Audio Recording Mode [AUDIO-REC] (→ 19, 33)

[AV IN/OUT SETUP] Sub-Menu

- 16) AV Jack [AV JACK] (→ 33, 40, 53)
- 17) Audio Dubbing Input [A.DUB INPUT] (→ 33)
- 18) AD Conversion Output [DV OUT] (→ 40)

[DISPLAY SETUP] Sub-Menu (→ 16)

[OTHER FUNCTIONS] Sub-Menu (→ 16)

PLAYBACK FUNCTIONS

1) BLANK SEARCH ▶ ---- YES
 2) RECORD TO CARD ▶ ---- YES
 3) INDEX ▶ PHOTO SCENE
 4) AUDIO ▶ ST1 ST2 MIX
 5) AUDIO OUT ▶ STEREO L R
 6) RETURN ▶ ---- YES
 PUSH MENU TO EXIT

DIGITAL EFFECT

7) EFFECT ▶ OFF ON
 8) EFFECT SELECT
 ▶ OFF MULTI WIPE MIX
 STROBE NEGA SEPIA
 MONO TRAIL SOLARI
 MOSAIC MIRROR
 RETURN ▶ ---- YES
 PUSH MENU TO EXIT

CARD SETUP

9) REC MODE
 10) ▶ FINE NORMAL ECONOMY
 CREATE TITLE ▶ ---- YES
 RETURN ▶ ---- YES
 PUSH MENU TO EXIT

MULTI-PICTURES

11) SCAN MODE ▶ STROBE MANUAL
 12) SPEED ▶ FAST NORMAL SLOW
 13) SWING ▶ OFF ON
 RETURN ▶ ---- YES
 PUSH MENU TO EXIT

RECORDING SETUP

14) REC-SPEED ▶ SP LP
 15) AUDIO-REC ▶ 12H 18H
 RETURN ▶ ---- YES
 PUSH MENU TO EXIT

AV IN/OUT SETUP

16) AV JACK
 17) ▶ IN/OUT OUT/PHONES
 18) A.DUB INPUT ▶ MIC AV IN
 DV OUT ▶ OFF ON
 RETURN ▶ ---- YES
 PUSH MENU TO EXIT

DISPLAY SETUP

DATE/TIME ▶ OFF D/T DATE
 C. DISPLAY ▶ LINEAR MEMORY
 T. CODE
 C. RESET ▶ ---- YES
 DISPLAY ▶ ALL PARTIAL OFF
 LCD MODE ▶ NORMAL BRIGHT
 LCD/EVF SET ▶ ---- YES
 RETURN ▶ ---- YES
 PUSH MENU TO EXIT

OTHER FUNCTIONS

REMOTE ▶ VCR1 VCR2 OFF
 CLOCK-SET ▶ ---- YES
 RETURN ▶ ---- YES
 PUSH MENU TO EXIT

Card Playback Mode Main-Menu

[DELETE PICTURE/TITLE] Sub-Menu

- 1) 1. DELETE PICTURE BY SELECTION
 - 2) 2. DELETE ALL PICTURES
 - 3) 3. DELETE TITLE BY SELECTION
- RETURN ▶ ---- YES
PUSH MENU TO RETURN

[DELETE PICTURE/TITLE] Sub-Menu

- 1) Selecting and deleting a Picture [DELETE PICTURE BY SELECTION] (→ 38)
- 2) Deleting All Pictures [DELETE ALL PICTURES] (→ 38)
- 3) Selecting and Deleting a Title [DELETE TITLE BY SELECTION] (→ 38)

[CARD EDITING] Sub-Menu

- 4) RECORD TO TAPE ▶ ---- YES
 - 5) PICTURE SEARCH ▶ ---- YES
 - 6) FILE LOCK ▶ ---- YES
 - 7) DPOF SETTING ▶ ---- YES
 - 8) CARD FORMAT ▶ ---- YES
- RETURN ▶ ---- YES
PUSH MENU TO EXIT

[CARD EDITING] Sub-Menu

- 4) Recording to Cassette [RECORD TO TAPE] (→ 36)
- 5) Searching a Picture [PICTURE SEARCH] (→ 36)
- 6) Setting the Lock [FILE LOCK] (→ 38)
- 7) Setting DPOF [DPOF SETTING] (→ 39)
- 8) Formatting a Card [CARD FORMAT] (→ 39)

[DISPLAY SETUP] Sub-Menu (→ 16)

- DATE/TIME▶OFF D/T DATE
C. DISPLAY▶LINEAR MEMORY
T. CODE
C. RESET ▶---- YES
DISPLAY ▶ALL PARTIAL OFF
LCD MODE ▶NORMAL BRIGHT
LCD/EVF SET ▶---- YES
- RETURN ▶ ---- YES
PUSH MENU TO EXIT

[DISPLAY SETUP] Sub-Menu (→ 16)

[OTHER FUNCTIONS] Sub-Menu (→ 16)

- REMOTE ▶VCR1 VCR2 OFF
CLOCK-SET ▶---- YES
- RETURN ▶ ---- YES
PUSH MENU TO EXIT

[OTHER FUNCTIONS] Sub-Menu (→ 16)

- 9) PICTURE SEARCH
- 10) DELETE PICTURE
- 11) FILE LOCK
- 12) DPOF SETTING
- 13) EXIT

Card Playback Mode Short-Cut Menu

Short-cut menus enable some of the Card Playback Mode menus to be called quickly. Press the [PUSH] Dial to display the short-cut menus, and rotate the [PUSH] Dial and then press it to select the desired menu.

- 9) [PICTURE SEARCH]:
The [PICTURE SEARCH] menu for searching pictures from numbers appears.
- 10) [DELETE PICTURE]:
The [DELETE PICTURE] menu for erasing the displayed picture appears. Use this menu after the picture to be erased has appeared.
- 11) [FILE LOCK]:
The [FILE LOCK] menu to prevent the accidental erasure of the displayed picture (lock setting) appears. Use this menu after the picture to be locked has appeared.
- 12) [DPOF SETTING]:
The [DPOF SETTING] menu for performing the DPOF settings for the displayed picture appears. Use this menu after the picture whose DPOF settings are to be performed has appeared.
- 13) [EXIT]: This is for exiting from the short-cut menu.

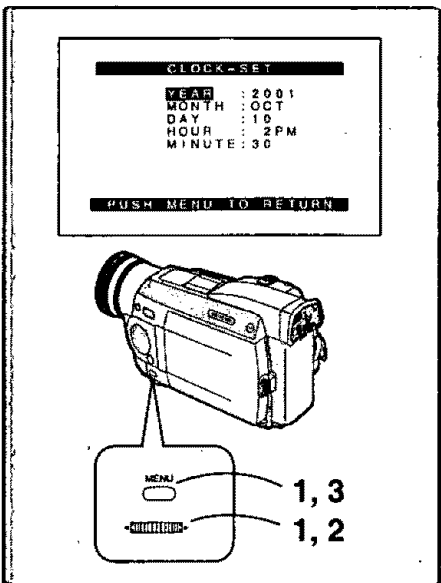

Setting Date and Time

- 1 Press the [MENU] Button and rotate the [PUSH] Dial to select [OTHER FUNCTIONS] >> [CLOCK-SET] >> [YES].
- 2 Rotate and press the [PUSH] Dial to select [YEAR]/[MONTH]/[DAY]/[HOUR]/[MINUTE] and set it to a desired value.
 - Year will cycle in the order shown below.
2000 → 2001 → ... → 2089 → 2000 → ...
- 3 Press the [MENU] Button to finish setting the date and time.
 - The clock operation starts from [00] second.
 - The menu will disappear when the button is pressed again.

• It is possible that the built-in clock in the Palmcorder may become inaccurate. Please check the time before recording. If the [⊗] Indication is flashing, charge the built-in lithium battery and reset the date and time.

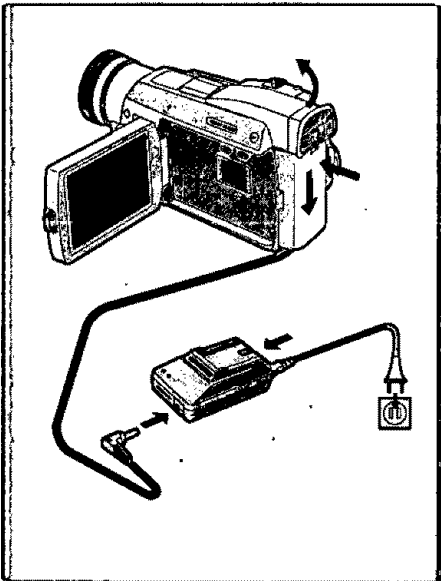

Internal Lithium Battery Recharge

The internal lithium battery sustains the operation of the clock. When the [⊗] Indication is lit, the internal lithium battery is near exhaustion.

- 1 Connect the AC Adaptor to the Palmcorder with the power turned off and then connect to the AC Jack.
 - After charging for 4 hours, the built-in lithium battery can power the clock for approximately 3 months.

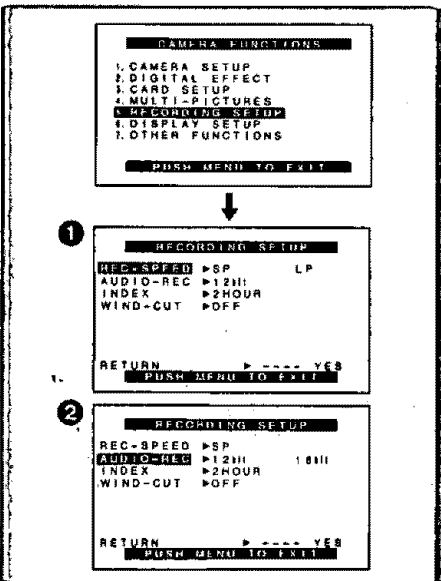

LP Mode

A desired recording speed can be selected with [REC-SPEED] on the [RECORDING SETUP] Sub-Menu. ①

If LP Mode is selected, the recording time becomes 1.5 times longer than that of SP Mode. Although the image quality does not decrease with the LP Mode recording, mosaic-like noise patterns may appear on a playback image, or some normal functions may be restricted.

- The contents that are recorded in LP Mode are not completely compatible with other equipment.
- Audio Dubbing is not possible with LP Mode. (→ 33)

Audio Recording Mode

The sound quality of the recorded sound can be selected with [AUDIO-REC] on the [RECORDING SETUP] Sub-Menu. ② High sound-quality recording is possible with "16bit 48kHz 2 track" Mode. With the "12bit 32kHz 4 track" Mode, the original sound can be recorded on 2 tracks in stereo, while the other 2 tracks can be used for re-recording.

Recording

1 Set the [OFF/ON/MODE] Switch to [ON].

- The [CAMERA] Lamp lights up. ①

2 Press the Recording Start/Stop Button.

- Recording starts.
- After the [RECORD] is displayed, it changes to [REC]. ②
- The Tally Lamp (LED Lamp) ③ lights up during recording and alerts those being recorded that recording is in progress. The Tally Lamp does not light up if the [TALLY LED] on the [OTHER FUNCTIONS] Sub-menu is set to [OFF].

3 Press the Recording Start/Stop Button again to pause the recording.

- [PAUSE] is displayed. ④

- If the Recording Pause Mode continues for more than 5 minutes, the power is turned off automatically for tape protection and power conservation. To resume recording from this condition, turn on the power again.

- When recording while the Mode Selector Switch is set to [AUTO] ⑤, the Palmcorder automatically adjusts the focus and white balance. (In some cases, they cannot be adjusted automatically and need to be adjusted manually.) (→ 24, 25)

- For other notes, see page 51.

■ To Check the Recording

By pushing the [G] Button ⑥ in the Recording Pause Mode, you can play back the last few seconds of the recorded scene.

- [CHK] is displayed. After checking, the Palmcorder resumes the Recording Pause Mode.
- For other notes, see page 51.

■ To View the recorded scene while the Recording is paused (Camera Search)

The recorded scene can be viewed by holding down the [−SEARCH] Button ⑦ or [SEARCH+] Button ⑧ in the Recording Pause Mode.

The Camera Search function is useful for finding the starting point of a new scene to create a smooth transition of one scene to another.

- When the [−SEARCH] Button is pressed, images are played back in the reverse direction.
- When the [SEARCH+] Button is pressed, images are played back in the forward direction.
- For other notes, see page 51.

■ Self-Recording

By opening the LCD Monitor and turning it so that it faces forward (to the lens side) ⑨, you can let the subject in front of the Palmcorder monitor the shot while shooting is in progress.

- When the LCD Monitor is opened, the Viewfinder is disabled automatically. However, when the LCD Monitor is rotated forward, the image is also shown in the Viewfinder.
- If you prefer to have the image on the LCD Monitor to look like an image in a mirror, set [SELF-REC] on the [OTHER FUNCTIONS] Sub-Menu to [MIRROR]. (Mirror Mode)
Images are recorded normally and no left and right reversal occurs.
- If [MIRROR] is selected, only recording Indication [●], recording pause Indication [●|●], Card PhotoShot Indication [📷] and Remaining Battery Power Indication [🔋] are displayed. If a general Warning/Alarm r Indication [!] appears, return the LCD Monitor to the original position in order to check the specific content of the Warning/Alarm Indication.

■ To Finish the Recording

Set the [OFF/ON/MODE] Switch to [OFF].

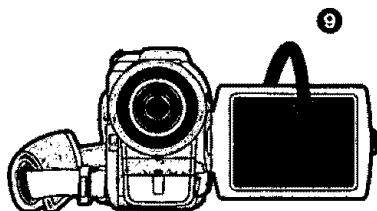
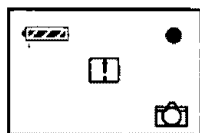
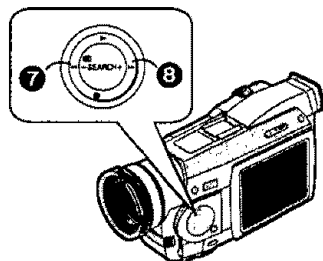
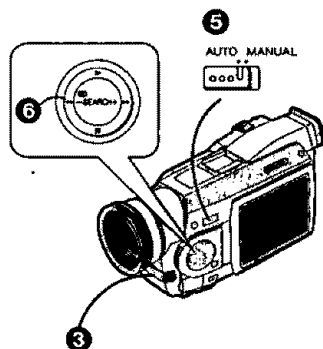
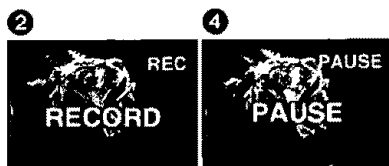
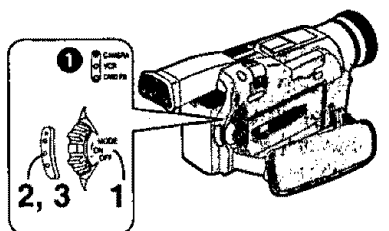

PhotoShot Recording on the DV Cassette

With this function, you can record still pictures with sound for approximately 7 seconds each on the Cassette.

1 Slide the [TAPE/CARD] Selector to [TAPE].

2 Press the [PHOTO SHOT] Button in the Recording Pause Mode.

- The Palmcorder records a still picture for about 7 seconds and then switches back to the Recording Pause Mode.

- Photoshot Recording results in slightly inferior image quality.

Progressive Photoshot

With the progressive Photoshot Function, you can record still pictures with higher resolution than with the normal Photoshot Function.

- After setting [PROGRESSIVE] on the [CAMERA SETUP] Sub-menu to [ON] or [AUTO], press the [PHOTO SHOT] Button in the Recording Pause Mode. [P] is displayed. ①

- This Function may not work with some function settings. (→ 51)

Continuous Photoshot

If the [PHOTOSHOT] Button is held down with the [SHUTTER] of the Sub-Menu [OTHER FUNCTIONS] set to [ON], the Palmcorder will record still images without interruptions every 0.7 seconds until the button is released.

- The screen blinks and, at the same time, a shutter clicking sound is recorded. (However, this function is not enabled when Progressive Photoshot is set to [ON] or [AUTO].)

Digital Still Picture

When the [CAMERA STILL] Button ② is pressed, images become still pictures. When the Button is pressed again, the Digital Still Picture Mode is cancelled.

- We recommend that you press the [CAMERA STILL] Button first at the position where you want to record the picture and then press the [PHOTO SHOT] Button.

- For the still pictures taken in the Continuous Photoshot Mode or Digital Still Picture Mode, photoshot index signals are not recorded.

Zoom In/Out Functions

It gives special effects to the Palmcorder by Recording objects close by or with wide-angle shot.

1 For wide-angle shots (zoom out):

Press the [W/T] zoom lever towards [W].

For close-ups (zoom in):

Press the [W/T] zoom lever towards [T].

- Zoom magnification is displayed for a few seconds.

- Generally speaking, when the [W/T] zoom lever is pressed towards [W] or [T], the zooming speed gradually increases.

Taking Close-up Shots of Small Subjects (Macro Close-up Function)

When the zoom magnification is 1×, the Palmcorder can focus on a subject that is as close as approximately 1.5 inch (35 mm) from the lens. With this, small subjects like insects can be recorded.

- For other notes, see page 51.

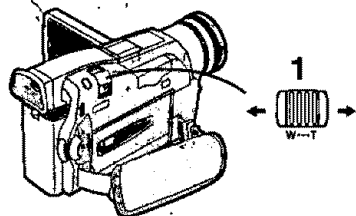
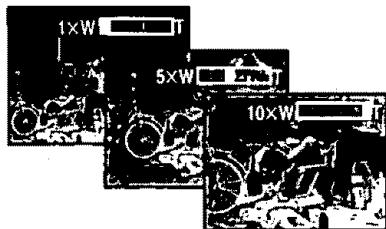
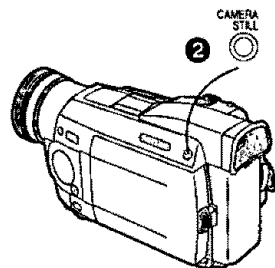
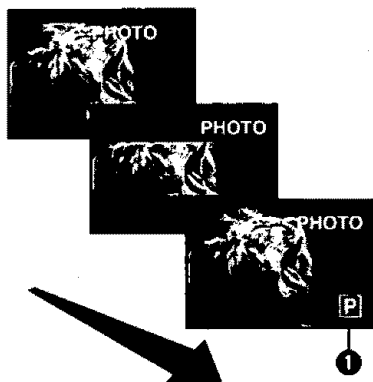
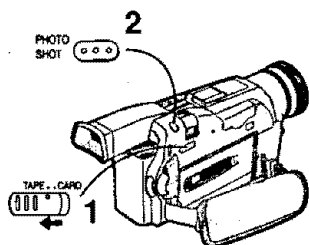

CAMERA

Digital Zoom Function

This function is useful when you want to record close-up shots of subjects located beyond a normal zoom range of 1X to 10X magnification. With the digital zooming Function, you can select a magnification of 25X or even to 100X.

- 1 Set [CAMERA FUNCTIONS] >> [CAMERA SETUP] >> [D.ZOOM] >> [25x] or [100x]

- 25x: Digital zooming to 25x
- 100x: Digital zooming to 100x

- 2 To zoom in or out, press the [W/T] zoom lever towards [W] or towards [T].

- As the magnification of digital zooming increases, the quality of image may deteriorate.

Canceling the Digital Zooming Function

Set [D.ZOOM] on the [CAMERA SETUP] Sub-menu to [OFF].

For other notes, see page 51.

Digital Electronic Image Stabilizer Function

If you are recording in unstable situations and the Palmcorder is shaky, you can use this function to correct the distortion in these images.

- If the Palmcorder shakes too much, this Function may not be able to stabilize images.

- 1 Set [CAMERA FUNCTIONS] >> [CAMERA SETUP] >> [EIS] >> [ON]

- The [EIS] Indication ① appears.

Canceling Digital Electronic Image Stabilizer

Set [EIS] on the [CAMERA SETUP] Sub-Menu to [OFF].

EIS function may not work when...

- Palmcorder movement is too extreme.
- Recording a subject with distinct horizontal or vertical stripes.
- Recording in low light situations.
- Recording a subject under a great amount of fluorescent light.
- Recording a scene with very fast motions.

For other notes, see page 51.

Fade In/Out Functions

Fade In ①

Fade In brings out images and sounds gradually from a black screen at the beginning of a scene.

- 1 Hold down the [FADE] Button while the Palmcorder is set to the Recording Pause Mode.

- The image fades out gradually.

- 2 When the image is completely gone, press the Recording Start/Stop Button to start recording.

- 3 Release the [FADE] Button about 3 seconds after starting recording.

- The image reappears gradually.

Fade Out ②

Fade Out causes images and sounds to disappear gradually, leaving a black screen at the end of a scene.

- 1 Hold down the [FADE] Button while recording.

- The image fades out gradually.

- 2 About 3 seconds after the image is completely gone, press the recording Start/Stop Button to stop recording.

- 3 Release the [FADE] Button.

For other notes, see page 51.

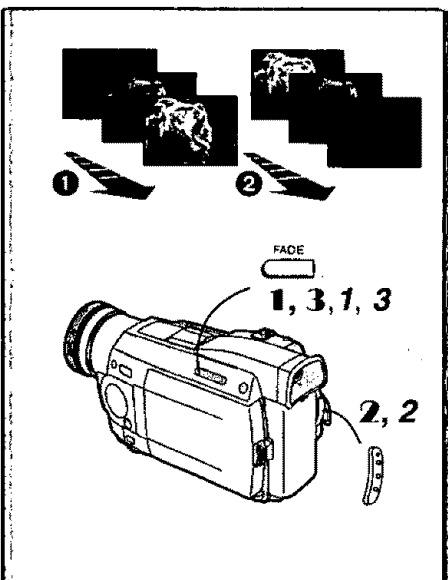
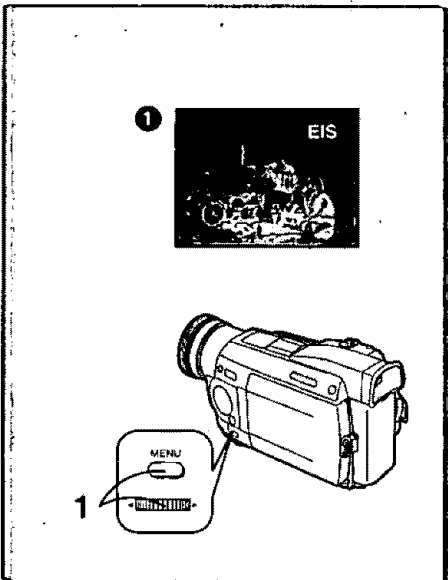
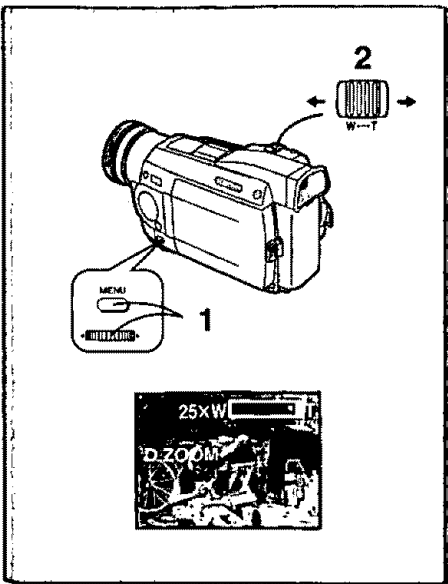

Backlight Compensation Function

This prevents a recording subject from being recorded darker in backlight. (Backlight is the light that shines from behind a recording subject.)

1 Press the [BACK LIGHT] Button..

- The [] Indication ❶ flashes and then is displayed.

To resume normal Recording

Press the Backlight Button [BACK LIGHT].

- When the [BACK LIGHT] Button is pressed, the entire screen becomes brighter.
- By operating the [OFF/ON/MODE] Switch, the Backlight Compensation Function is cancelled.

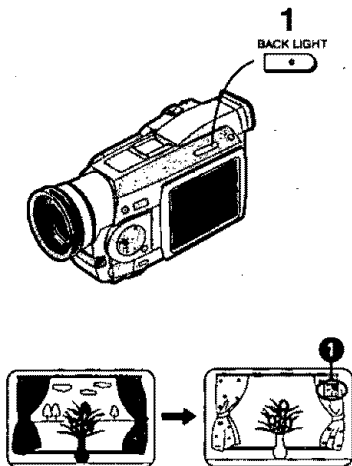

Recording in Special Situations

(Program AE)

Select optimal automatic exposures under specific recording situations.

1 Set the Mode Selector Switch to [MANUAL].

- The [MNL] Indication appears.

2 Set [CAMERA FUNCTIONS] >> [CAMERA SETUP] >>

[PROG.AE] >> a desired Mode [], [], [], [], [].

- The Indication of the selected Mode is displayed.

[] Sports Mode ❶

For Recording scenes involving quick movements, such as sports scenes.

[] Portrait Mode ❷

Focuses on the main subject of the image and leaves the background slightly out of focus.

[] Low Light Mode ❸

Preserves the mood of dim light settings without altering picture brightness.

[] Spotlight Mode ❹

Neutralizes the additional brightness created by a spot light.

[] Surf & Snow Mode ❺

Compensates for excessive illumination from sun glare to produce a clear picture.

Canceling the Program AE Function

Set [PROG.AE] on the [CAMERA SETUP] Sub-Menu to [OFF]. Or, set the Mode Selector Switch to [AUTO].

- For other notes, see page 51.

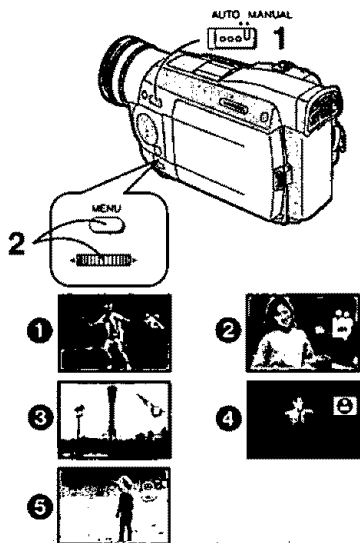

CAMEDIA

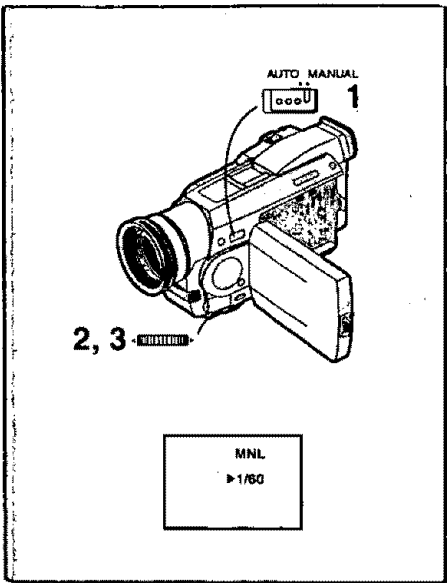

Manual Shutter Speed Adjustment

Useful for Recording fast-moving subjects

- 1 Set the Mode Selector Switch to [MANUAL].
 - The [MNL] Indication appears.
- 2 Press the [PUSH] Dial repeatedly until the shutter speed display appears.
- 3 Rotate the [PUSH] Dial to adjust the shutter speed.

The Range of Shutter Speed Adjustment

1/60—1/8000 (or 1/30-1/500: for Mega Pixel Recording)

The standard shutter speed is 1/60 (or 1/30: for Mega Pixel Recording).

Selecting a speed closer to [1/8000] causes the shutter speed to be faster.
 • When the progressive function is [ON], a speed only up to 1/500 can be used.

To Resume Automatic Adjustment

Set the Mode Selector Switch to [AUTO].

• For other notes, see page 52.

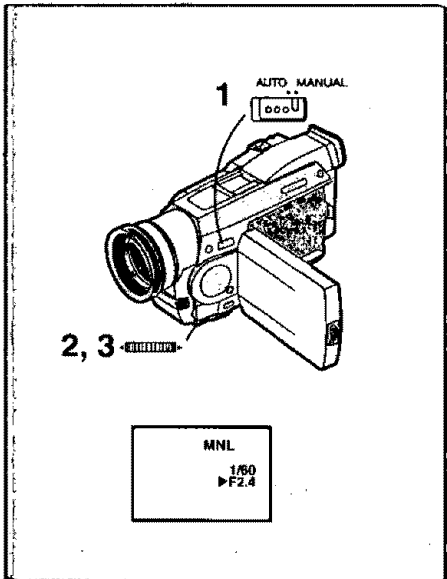

Manual Iris Adjustment (F Number)

You can use this function when the screen is too bright or too dark.

- 1 Set the Mode Selector Switch to [MANUAL].
 - The [MNL] Indication appears.
- 2 Press the [PUSH] Dial repeatedly until the [F] Indication appears.
- 3 Rotate the [PUSH] Dial to adjust the iris.

Adjustable Range of the Iris

CLOSE (Closed)→ F16...F2.0→

OP (Opened)+0dB→ OP+3dB...→ OP+18dB

When a value closer to [CLOSE] is selected, the image becomes darker.

When a value closer to [OP+18dB] is selected, the image becomes brighter.

The value to which +dB is attached indicates a gain value. If this value is too large, the quality of the image deteriorates.

To Resume Automatic Adjustment

Set the Mode Selector Switch to [AUTO].

• For other notes, see page 52.

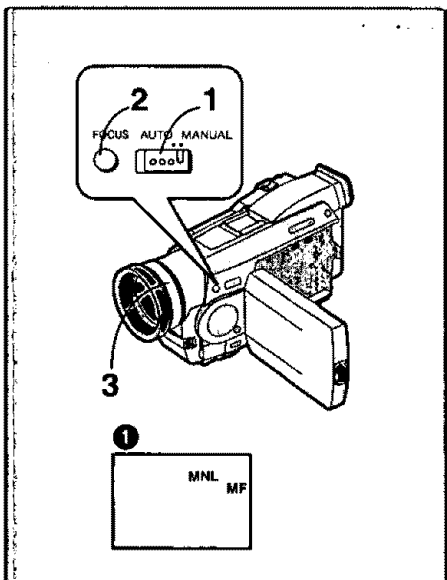

Manual Focus Adjustment

Focus can be adjusted manually for recording in a situation where auto focus may not function well.

- 1 Set the Mode Selector Switch to [MANUAL].
 - The [MNL] Indication appears.
- 2 Press the [FOCUS] Button.
 - The [MF] Indication (Manual Focus Mode) ❶ appears.
- 3 Rotate the Focus Ring to adjust the focus.

To Resume Automatic Adjustment

Press the [FOCUS] Button to turn off the [MF] Indication. Or, set the Mode Selector Switch to [AUTO].

Recording in Natural Colors

(White Balance)

Depending on the scene or light condition, the Automatic White Balance Adjustment Mode may not be able to bring out natural colors. In such a case, the white balance can be adjusted manually.

1 Set the Mode Selector Switch to [MANUAL].

- The [MNL] Indication appears.

2 Press the [PUSH] Dial.

- The [AWB] Indication appears.

3 Rotate the [PUSH] Dial to set a desired White Balance Mode.

- 1 Automatic White Balance Adjustment [AWB]
- 2 The White Balance setting that was previously set manually
- 3 Fluorescent light Mode
- 4 Outdoor Mode
- 5 Indoor Mode (shooting under incandescent lamp)

To Resume Automatic Adjustment

Rotate the [PUSH] Dial until the [AWB] Indication appears. Or, set the Mode Selector Switch to [AUTO].

- For other notes, see page 52.

Adjusting White Balance Manually

When the Auto White Balance Adjustment function does not operate under the existing light conditions, use the Manual White Balance Adjustment mode.

1 Set the Mode Selector Switch to [MANUAL].

- The [MNL] Indication appears.

2 Press the [PUSH] Dial.

- The [AWB] Indication appears.

3 Rotate the [PUSH] Dial until the [MNL] Indication is displayed.

4 Point the Palmcorder at a full-screen white subject, and then keep the [PUSH] Dial pressed until Indication [MNL] stops flashing.

- When the [MNL] Indication flashes after turning the Palmcorder on, the previously adjusted white balance setting is still kept.

To Resume Automatic Adjustment

Rotate [PUSH] Dial until the [AWB] Indication is displayed. Or, set the Mode Selector Switch to [AUTO].

Use of Auto White Balance Adjustment in inappropriate lighting conditions may result in reddish or bluish images. Where the subject is found on the left but surrounded by many light-sources, Auto White Balance Adjustment may not operate properly. In such case we suggest that you adjust the White Balance.

- 1) The range that is controlled by the Auto White Balance Adjustment Mode of this Palmcorder
- 2) Blue sky
- 3) Cloudy sky (Rain)
- 4) TV screen
- 5) Sunlight
- 6) White fluorescent light
- 7) Halogen light bulb
- 8) Incandescent light bulb
- 9) Sunrise and sunset
- 10) Candlelight

- For other notes, see page 52.

CAMERA

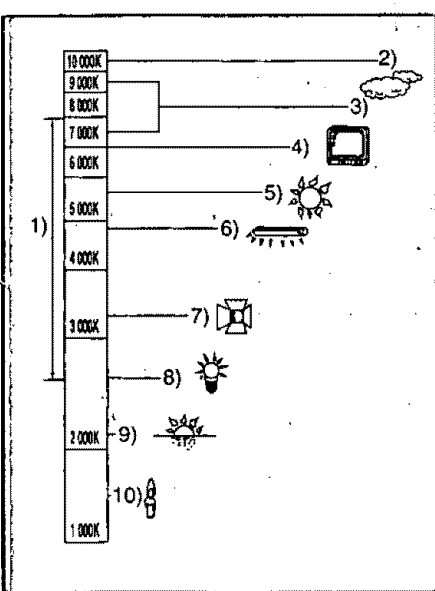
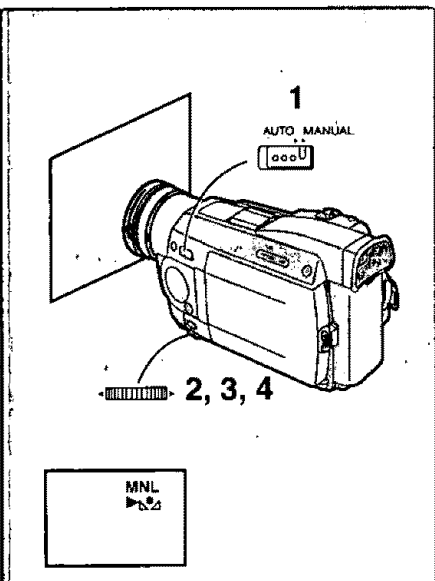
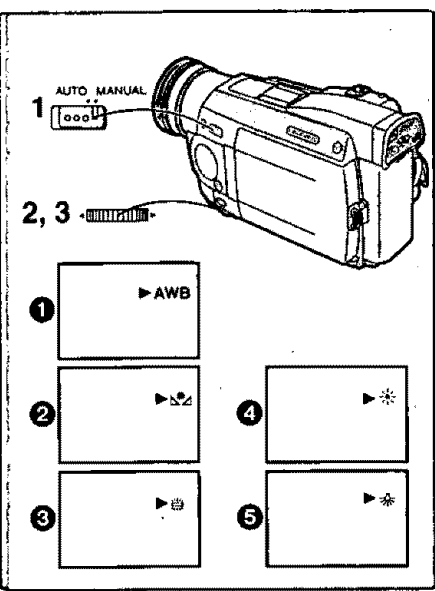

Digital Effect Functions

This Palmcorder is equipped with digital effect Functions that add special effects to the scene.

Digital Effects 1 [EFFECT1]

- 1) [MULTI] Multi-Picture Mode
- 2) [P-IN-P] Picture-in-Picture Mode
- 3) [WIPE] Wipe Mode
- 4) [MIX] Mix Mode
- 5) [STROBE] Strobe Mode
 - It records images with a stroboscopic effect.
- 6) [GAIN-UP] Gain-up Mode
 - It brightens images electronically.
 - Adjust focus manually when using this Mode.
- 7) [TRAIL] Trailing Effect Mode
 - It records images with a trailing effect.
- 8) [MOSAIC] Mosaic Mode
 - It produces a mosaic-like image.
- 9) [MIRROR] Mirror Mode
 - The right half of an image becomes a mirror image of the left half.

Digital Effects 2 [EFFECT2]

- 10) [NEGA] Negative Mode
 - The colors of the recorded image are inverted as seen in a negative.
- 11) [SEPIA] Sepia Mode
 - It records a scene with a brownish tint, like the color of old pictures.
- 12) [MONO] Black&White Mode
 - It records an image in black and white.
- 13) [SOLARI] Solarization Mode
 - It records an image with a painting-like effect.

Selecting a desired digital effect

Set [CAMERA FUNCTIONS] >> [DIGITAL EFFECT] >> [EFFECT1] or [EFFECT2] >> a desired digital effect.

Canceling the digital effect

Set [CAMERA FUNCTIONS] >> [DIGITAL EFFECT] >> [EFFECT1] or [EFFECT2] >> [OFF].

• For other notes, see page 52.

1) MULTI



2) P-IN-P



3) WIPE



4) MIX



5) STROBE



6) GAIN-UP



7) TRAIL



8) MOSAIC



9) MIRROR



10) NEGA



11) SEPIA



12) MONO



13) SOLARI



Wipe Mode and Mix Mode

Wipe Mode:

Like a curtain is being pulled, the still picture of the last recorded scene gradually changes to the moving image of a new scene.

Mix Mode:

While the moving image of a new scene fades in, the still image of the last recorded scene gradually fades out.

1 Set [DIGITAL EFFECT] >> [EFFECT1] >> [WIPE] or [MIX].

- The [WIPE] or [MIX] indication appears.

2 Press the Recording Start/Stop Button to start Recording.

3 Press the Recording Start/Stop Button to pause the Recording.

- The last scene is stored in memory. The [WIPE] or [MIX] indication changes to [WIPE] or [MIX].

4 Press the Recording Start/Stop Button to restart the Recording.

- The last image of the previous scene gradually changes to the new scene.

• For other notes, see page 52.

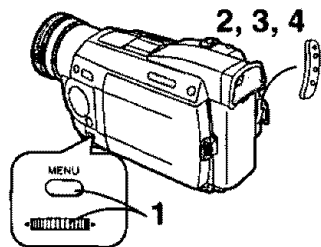

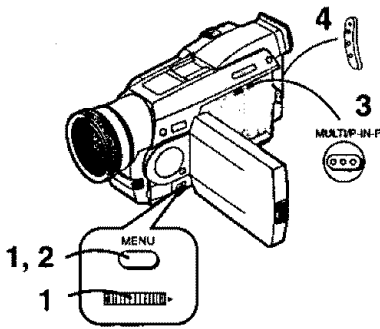

Multi-Picture Mode

Strobe Multi-Picture Mode ①:

You can capture and record 9 consecutive small still pictures.

Manual Multi-Picture Mode ②:

You can manually capture and record 9 small still pictures.

After setting [DIGITAL EFFECT] >> [EFFECT1] >> [MULTI].....

1 Set [MULTI-PICTURES] >> [SCAN MODE] >> [STROBE] or [MANUAL].

When [STROBE] is selected:

- Set the [SPEED] to a desired strobe speed.

[FAST]: You can capture 9 consecutive still pictures within approximately 1 second

[NORMAL]: You can capture 9 consecutive still pictures within approximately 1.5 seconds

[SLOW]: You can capture 9 consecutive still pictures within approximately 2 seconds

- If you set [SWING] on the [MULTI-PICTURES] Sub-Menu to [ON], the intervals at which the 9 still pictures are taken are longer at the beginning and end than in the middle of the swing strobe period, and it is useful for analyzing swing motion, etc., in sports.

When [MANUAL] is selected:

- You can select a desired scene one at a time up to 9 small pictures.

2 Exit the menu by pressing the [MENU] Button.

3 Press the [MULTI] Button.

- If [MANUAL] is selected, press the [MULTI] Button at each scene you want to capture.

4 Press the Recording Start/Stop Button or the [PHOTOSHOT] Button to record on the Cassette.

Deleting all the captured Multi pictures

While 9 multi-pictures are displayed, press the [MULTI] Button.

- If [MANUAL] has been selected, press the [MULTI] Button after 9 pictures are displayed.

To Display the Multi Pictures again

Press the [MULTI] Button for 1 second or longer.

To Delete Multi pictures one by one

(When pictures were captured in [MANUAL])

When the [MULTI] Button is pressed for 1 second or longer while the still pictures are displayed, the picture captured last is deleted. If you keep pressing the [MULTI] Button, the pictures are deleted continuously.

- After still pictures are deleted one by one, they cannot be displayed again.

- For other notes, see page 52.

Picture-in-Picture Mode

You can display a sub-screen (still picture) inside the screen.

After setting [DIGITAL EFFECT] >> [EFFECT1] >> [P-IN-P].....

1 Select [P-IN-P] on the [MULTI-PICTURES] Sub-Menu and set the position (①②③④) where you want to insert a small still picture.

2 Exit the menu by pressing the [MENU] Button.

3 Aim the Palmcorder at the scene you want to capture and press the [P-IN-P] Button to insert a small still picture.

- A small still picture is displayed in a Normal picture.
- If the [P-IN-P] Button is pressed again, the small still picture is cleared.

4 Press the Recording Start/Stop Button or the [PHOTOSHOT] Button to record on the Cassette.

- For other notes, see page 52.

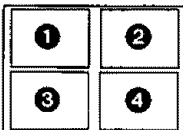
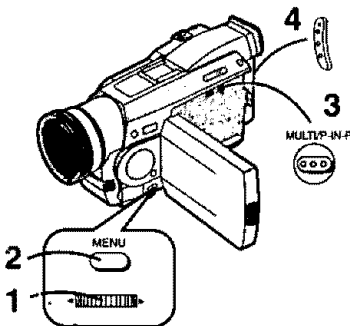

PALMSTAR

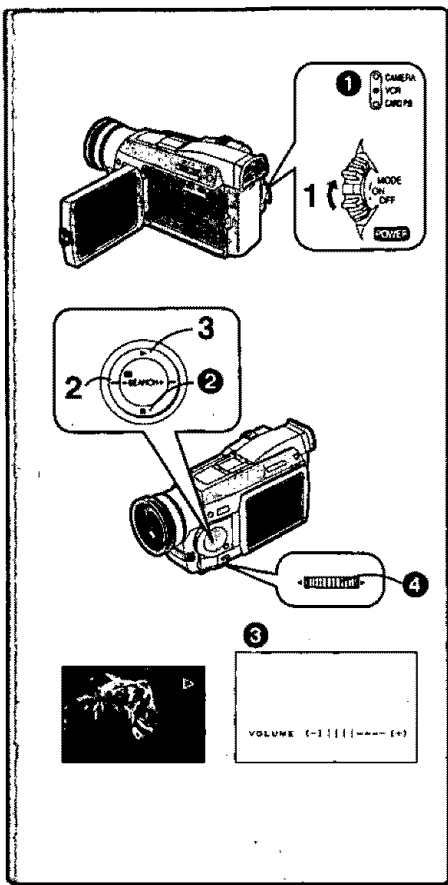

Playing Back

The recorded scene can be played back immediately after recording.

1 Slide the [OFF/ON/MODE] Switch and set the Pالمcorder in the VCR Mode.

- The [VCR] Lamp lights up. ①

2 Press the [◀◀] Button to rewind the tape.

- Rewind the tape to the point where you want to start playback.
- When the tape reaches the beginning, rewinding stops automatically.

3 Press the [▶] Button to start playback.

To Stop Playback

Press the [■] Button ②.

- If a Cassette recorded with copyright protection signals is played back, the screen becomes blue or mosaic-like noise patterns.

Adjusting the Sound Volume

Until the [VOLUME] Indication ③ appears, keep pressing the [PUSH] Dial

④. Then, rotate the [PUSH] Dial to adjust the volume. After the adjustment, press the [PUSH] Dial to make the [VOLUME] Indication disappear.

To adjust the volume with the Remote Controller, press the [T] or [W] Button to display the [VOLUME] Indication. Press the [T] Button to increase the volume or press the [W] Button to decrease the volume. The [VOLUME] Indication goes off 2 or 3 seconds after the adjustment is finished.

- When the Playback Zoom Function is in use, the sound volume cannot be adjusted.

- For other notes, see page 53.

Finding a Scene You Want to Play Back

Cue/Review Playback

Cue Playback (A)

Keep the Cue Button [▶▶] ① pressed during playback.

Review Playback (B)

Keep the Review Button [◀◀] ② pressed during playback.

- For longer Cue or Review Playback, press the Cue Button [▶▶] or the Review Button [◀◀] only briefly. As this locks the search function, you do not need to keep the button pressed for a long time.
- To resume normal playback, press the Play Button [▶]. In Cue and Review Playback, pictures with fast-moving subjects may contain mosaic-like noise patterns.

Variable Speed Search Function

The speed of Cue Playback or Review Playback can be varied.

1 During playback, press the [▶] Button.

- [1X▶] Indication appears. (C)

2 Rotate the [PUSH] Dial and select a desired search speed.

The following 6 playback speeds are available for the Variable Speed Search Function in both the fast-forwarding and rewinding directions. 1/5 X (slow playback, SP mode only), 1/3 X (slow playback, LP mode only), 1 X, 2 X, 5 X, 10 X, and 20 X.

- The same setting can be performed using the Remote Controller.

Resuming Normal Playback

Press the [▶] Button.

- During Cue or Review Playback, fast-moving images may show mosaic-like noise patterns.
- The sound is muted during search.

Repeat Playback

If you continue to press the Playback Button [▶] for 5 seconds or longer, the Pالمcorder switches to Repeat Playback Mode, and the [R▶] Indication appears (D). (To cancel Repeat Playback Mode, set the [OFF/ON/MODE] Switch to [OFF].)

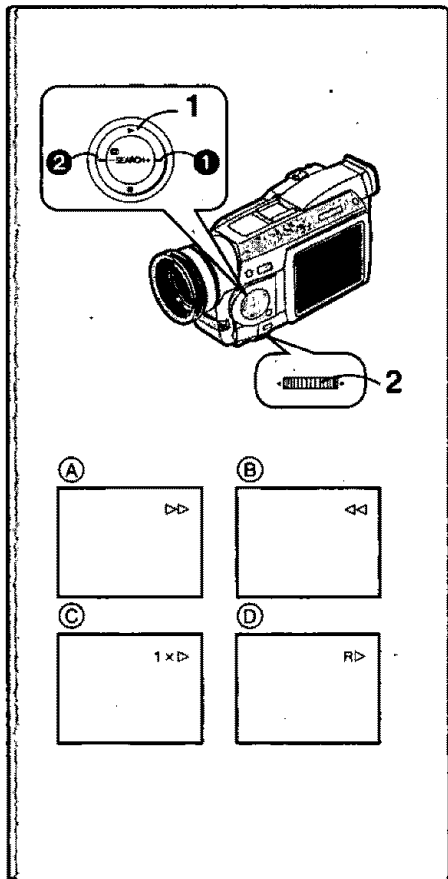

Slow Motion Playback

This Palmcorder can play back at a slow speed.

- 1 Press the [▶] Button.
- 2 Press the [◀] Button or the [▶] Button on the Remote Controller.

- When the [◀] Button is pressed, Slow Motion Playback proceeds in the reverse direction, while pressing the [▶] Button starts Slow Motion Playback in the forward direction.

Scenes recorded in the SP mode are played back at approximately 1/5th of the normal speed.

Scenes recorded in the LP mode are played back at approximately 1/3rd of the normal speed.

Resuming Normal Playback

Press the [▶] Button.

Still Playback/Still Advance Playback

This Palmcorder is capable of still picture playback and frame-advance playback.

- 1 Press the [▶] Button.
- 2 Press the [II] Button.
- 3 Press the [◀] Button or the [▶] Button on the Remote Controller.

- The playback image stops in the Still Playback Mode.
- With each pressing of the [◀] Button, still pictures advance in the reverse direction. With each pressing of the [▶] Button, still pictures advances in the forward direction. If either one of the Buttons continues to be pressed, still pictures advance continuously one frame at a time until the Button is released.

Resuming Normal Playback

Press the [▶] Button or [II] Button.

Jog Playback

By rotating the Jog Dial ([PUSH] Dial) ① of the Palmcorder in the Still Playback Mode, still pictures can be advanced one frame at a time in the forward or backward direction.

- If the Palmcorder is left in the Still Playback Mode for more than 5 minutes, the Palmcorder switches to the Stop Mode to protect the video heads from excessive wear and tear.

Finding the End of Recording

(Blank Search Function)

The Blank Search Function helps you to locate the end of the Recording on the Cassette quickly.

- 1 Set [VCR FUNCTIONS] >> [PLAYBACK FUNCTIONS] >> [BLANK SEARCH] >> [YES].

- The [BLANK] Indication appears.
- Approximately 1 second before the last recorded scene, the Palmcorder switches to the Still Playback Mode.
- If there is no blank portion left on the Cassette, the Palmcorder stops at the end of the tape.

Canceling Blank Search prior to completion

Press the [■] Button.

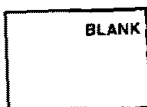
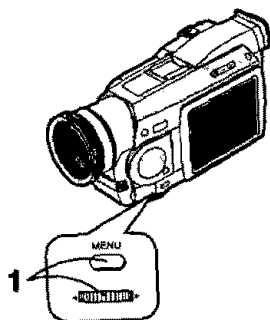
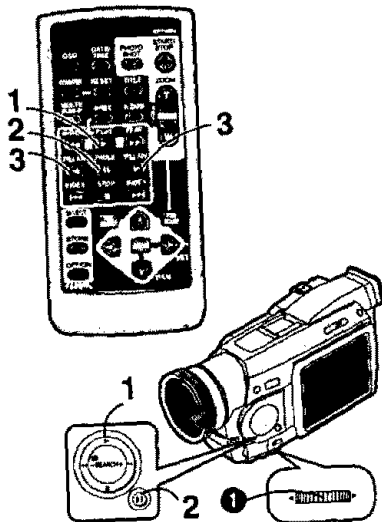
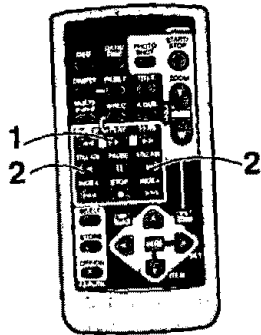

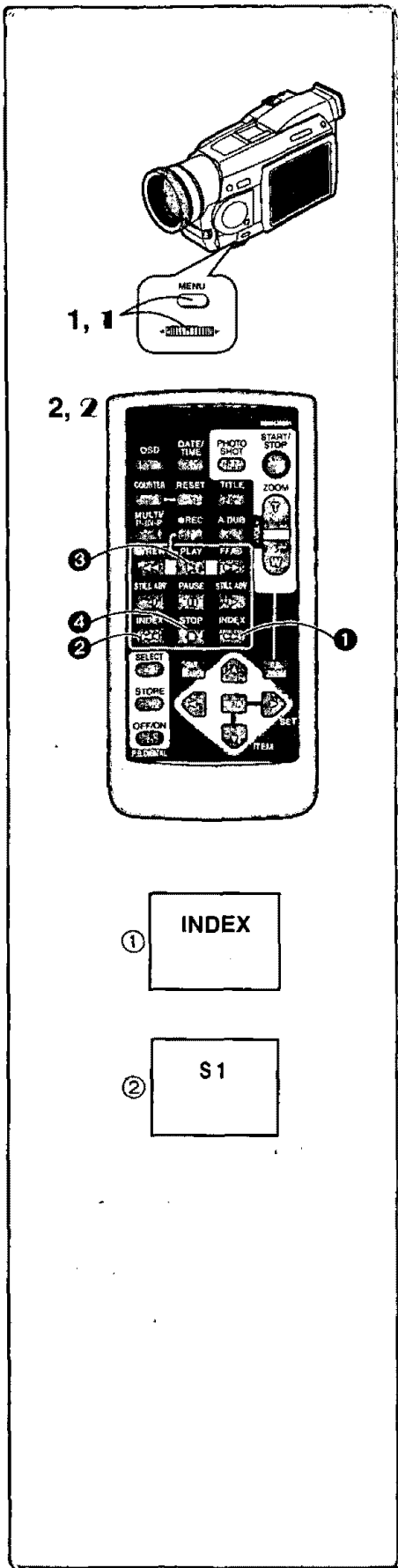

Index Search Functions

To facilitate searching of desired scene, this Palmcorder automatically records index signals during recording, as explained in the following.

Photoshot Index Signal

These signals are automatically recorded whenever still pictures are taken in Photoshot Mode (→ 21).

When recording still pictures using the Continuous Photoshot Mode (→ 21), the index signal is not recorded.

Scene Index Signal

Scene Index Signals are automatically recorded when you start recording after inserting a Cassette.

However, if the Palmcorder is switched from the VCR Mode to Camera Mode or if the date and time is set before the start of recording, the index signal is not recorded.

- If [INDEX] of [RECORDING SETUP] Sub-Menu on the [CAMERA FUNCTIONS] Main-Menu is set to [2HOUR], an index signal is recorded when Recording is restarted after an elapse of 2 hours or longer. If it is set to [DAY], an index signal is recorded when recording is restarted after the date has changed since the last recording. (While the index signal is recorded, the [INDEX] Indication ① flashes for a few seconds.)

Photoshot Index Search

- 1 Set [VCR FUNCTIONS] >> [PLAYBACK FUNCTIONS] >> [INDEX] >> [PHOTO].
- 2 Press the [▶▶] Button ① or the [◀◀] Button ② on the Remote Controller.

- With each press of the corresponding button, still pictures recorded in Photoshot Mode are searched.
- After Pictures with Sounds are played back for 4 seconds, the Palmcorder switches to the Still Playback Mode.

Scene Index Search

- 1 Set [VCR FUNCTIONS] >> [PLAYBACK FUNCTIONS] >> [INDEX] >> [SCENE].
- 2 Press the [▶▶] Button ① or the [◀◀] Button ② on the Remote Controller.

- When the corresponding Button is pressed once, the [S 1] Indication ② appears, and searching of the subsequent scene marked with an index signal starts. Each time the button is pressed after the start of Scene Index Search the indication changes from [S 2] to [S 9], and the beginning of the scene corresponding to the selected number will be searched. After reaching the desired scene, playback starts automatically.
- Up to 9 scene numbers can be selected.

Top Scan

If the [▶▶] Button or the [◀◀] Button is pressed for more than 2 seconds, the Palmcorder will scan for scenes (or PhotoShots) and playback the first few seconds of each. (To cancel, press the [▶] Button ③ or the [■] Button ④.)

- For other notes, see page 52.

Playback Zoom Function

A part of the image can be enlarged up to 10 times during playback.

- 1 During playback, press the **Playback Zoom Button [P.B. ZOOM]** on the Remote Controller.

- The center of the image is enlarged to approximately double the size.

Changing the Zoom Magnification

- 2 Change the magnification by pressing the **[W] or [T] Button** on the Remote Controller.

- You can increase the magnification up to 10x.

Changing the enlarged area of an image

- 3 Press the **Arrow Button (▲, ◀, ▶, ▼)** on the Remote controller that points to the area you want to enlarge.

- When the playback is stopped, the position of the enlarged image area is reset to the center automatically.

Canceling the Playback Zooming Function

Press the **[P.B.ZOOM]** Button on the Remote Controller.

- For other notes, see page 52.

Playback Digital Effect Functions

During playback, special Digital Effects can be added to the Recording. The digital effects that may be applied in the process of recording (except Picture in Picture Mode) will be the same as these added effects.

- 1 Press the **Play Button [▶]**.

- 2 Press the **[SELECT] Button** of the Remote Controller and select desired Digital Effect .

- When the [SELECT] Button is pressed repeatedly, the Digital Effect selection changes.

MULTI → WIPE → MIX → STROBE → NEGA → SEPIA → MONO
→ TRAIL → SOLARI → MOSAIC → MIRROR

- The same setting can also be set using the **[DIGITAL EFFECT]** on the **[VCR FUNCTIONS] Main-Menu**.

Suspending Playback Digital Effect temporarily

Press the **[OFF/ON] Button (Ⓛ)** to clear or restart the digital effect. When the Digital effect is paused temporarily, the selected effect's indication flashes.

Canceling the Digital Effect

Press the **[SELECT] Button** on the Remote Controller repeatedly until the Digital Effect Indication is cleared.

- For other notes, see page 52.

Playback with Wipe Mode and Mix Mode

- 1 Press the **[▶] Button** to start playback.

- 2 Press the **[SELECT] Button** of the Remote Controller and select **[WIPE]** or **[MIX]**.

- 3 Press the **[STORE] Button** at the moment you want to save as a still picture.

- The **[WIPE]** or **[MIX]** Indication appears, and the image is saved.

- 4 Press the **[OFF/ON] Button** in the scene in which you want to use the Wipe or Mix effect.

- The scene changes as a result of the Wipe or Mix effect.

- The Wipe Function and Mix Function can be used only from the Remote Controller during playback.

- If the **[OFF/ON] Button** is pressed while Wipe Function or Mix is used, the effect will stop temporarily at that point. Pressing the **[OFF/ON] Button** again will bring back the effect.

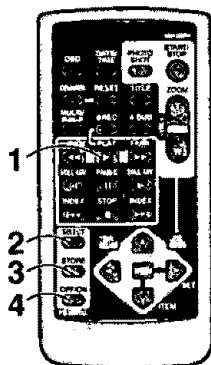
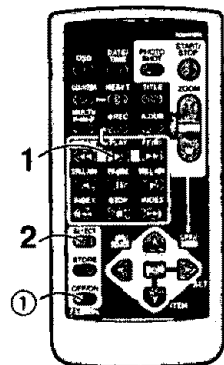
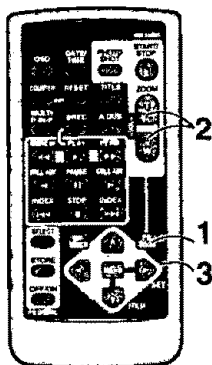

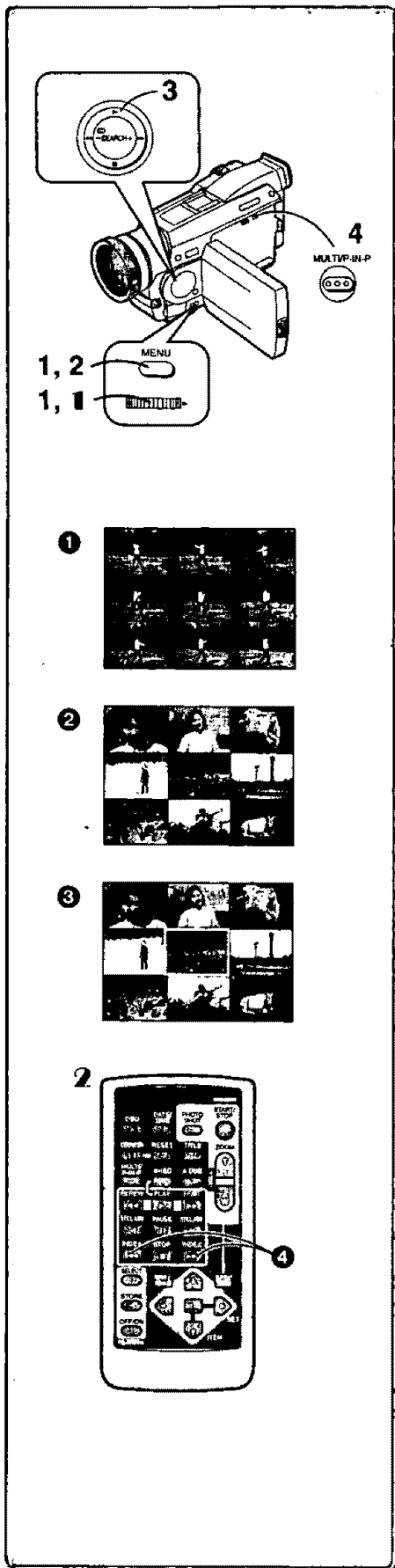

■ Playing Back with Multi-Picture Mode

Strobe Multi-Picture Mode [STROBE] ①:

You can capture 9 consecutive still pictures from playback images.

Manual Multi-Picture Mode [MANUAL] ②:

Selecting a desired still picture one at a time, you can capture 9 still pictures.

Index Multi-Picture Mode ([PHOTO], [SCENE]) ③:

You can capture 9 screens of pictures to which index signals are attached.

After setting [EFFECT SELECT] on the [DIGITAL EFFECT] Sub-Menu to [MULTI]....

1 Set [MULTI-PICTURES] >> [SCAN MODE] >> [STROBE] or [MANUAL] or [PHOTO] or [SCENE], whichever mode you prefer.

When [STROBE] is selected:

- Set the [SPEED] to a desired strobe speed.
 - [FAST]: You can capture 9 consecutive still pictures within approximately 1 second
 - [NORMAL]: You can capture 9 consecutive still pictures within approximately 1.5 seconds
 - [SLOW]: You can capture 9 consecutive still pictures within approximately 2 seconds
- If you set [SWING] on the [MULTI-PICTURES] Sub-Menu to [ON], the intervals at which the 9 still pictures are taken are longer at the beginning and end than in the middle of the swing strobe period, and it is useful for analyzing swing motion, etc., in sports.

2 Exit the Menu by pressing the [MENU] Button.

3 Play back the tape.

- If you select Index mode, it is not necessary to play back the tape.

4 Press the [MULTI] Button.

- If [STROBE] is selected: 9 screens are automatically captured from the point at which the Button is pressed.
- If [MANUAL] is selected: press the [MULTI] Button at each scene you want to capture. When 9 screens are captured, the tape will stop.
- If [PHOTO] or [SCENE] is selected: From the point at which the Button is pressed, 9 screens of pictures to which index signals are attached are captured in the playback direction. After 9 screens are captured, the tape will stop, but, if there are 8 or less pictures to be captured, the tape will stop at its end.

Deleting All the Captured Multi Pictures

While displaying the multi-pictures that have been captured, press the [MULTI] Button.

- If [MANUAL] has been selected, press [MULTI] Button after 9 screens are displayed.

To Display the Multi-pictures again

Press the [MULTI] Button for 1 second or longer.

To Delete Multi-pictures one by one (When Pictures have been captured in Manual Mode):

When the [MULTI] Button is pressed for 1 second or longer while the still pictures are displayed, the picture that was captured last is deleted. If you continue to press the Button, the pictures are deleted consecutively.

- After still pictures are deleted one at a time, they cannot be displayed again.

To Stop Capturing Pictures midway (When Pictures have been captured in Index Mode)

Press the [■] Button.

To Search the tape position of a desired picture among the playback pictures displayed on 9 screens

1 After displaying pictures in Multi Picture Mode, rotate the [PUSH] Dial to select the image whose tape position you want to search.

- The selected picture blinks at the red frame.

2 Press the Remote controller's Index Button [◀◀] or [▶▶] ④.

- A still picture playback takes place at the selected picture.

- For other notes, see page 52.

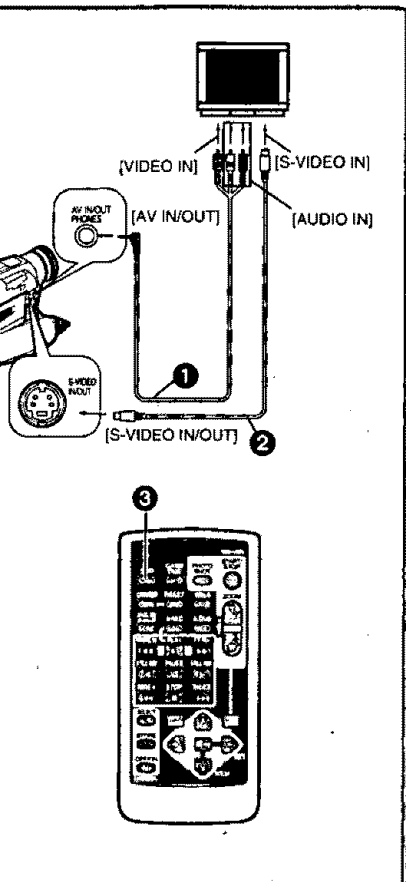

Playing Back on Your TV

By connecting your Palmcorder with your TV, the recorded scenes can be viewed on your TV screen.

• Before connecting them, turn off the power of both the Palmcorder and TV.

1 Connect the [AV IN/OUT] Jack of the Palmcorder to the Video and Audio Input Jacks of the TV.

- Using the A/V Cable ① (supplied), make a connection with the TV. If the TV has an S-Video Jack, connect the S-VHS Cable (not supplied) ②, too.

Making the Indications Appear on the TV screen

Press the [OSD] Button ③ on the Remote Controller.

- If you play back a Cassette recorded with copyright protection signals, the screen becomes blue or mosaic-like noise patterns.
- If you set [AV JACK] on the [AV IN/OUT SETUP] Sub-Menu to [IN/OUT], nothing will be shown on the TV screen except during playback.

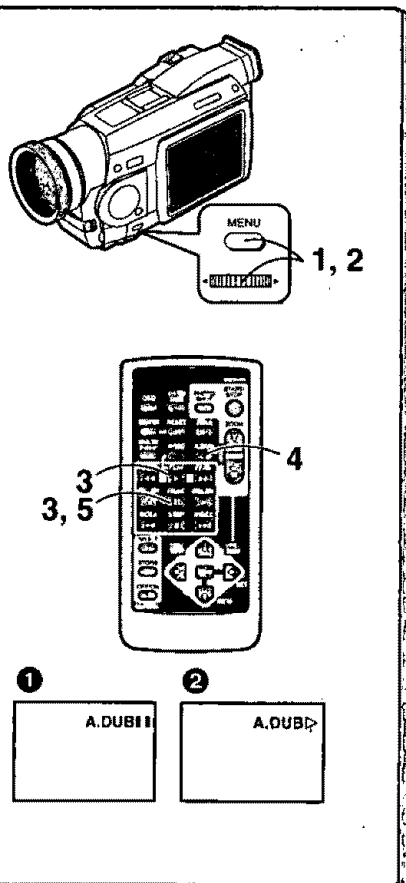

Audio Dubbing

You can add music or narration to the recorded Cassette.

- If you perform audio dubbing onto a tape that was recorded with [AUDIO REC] on the [RECORDING SETUP] Sub-Menu of the [CAMERA FUNCTIONS] Main-Menu set to [16bit], the original sound is erased. (If you want to preserve the original sound, use the [12bit] Mode when recording.)
- Audio Dubbing cannot be performed onto recordings made in LP Mode. (→ 19)

1 Set [VCR FUNCTIONS] >> [AV IN/OUT SETUP] >> [AV JACK] >> [IN/OUT].

2 And then select [A.DUB INPUT] >> [MIC] or [AV IN].

- Set to [AV IN] when external sound equipment is used, or set to [MIC] when an external or built-in microphone is used.

3 Press the [▶] Button, and then press the [II] Button at the point where you want to start dubbing.

4 Press the [A.DUB] Button on the Remote Controller.

- [A.DUB II] Indication appears. ①

5 To start Audio Dubbing, press the [II] Button on the Remote Controller.

- [A.DUB▶] Indication appears. ②

To Stop Audio Dubbing

Press the [II] Button on the Remote Controller.

The Palmcorder is in the Still Playback Mode again.

Playing Back the Sound Recorded with Audio Dubbing (For 12 bit Audio Recording)

Set [VCR FUNCTIONS] >> [PLAYBACK FUNCTIONS] >> [AUDIO] >> [ST2] or [MIX].

ST1: Play back only the original sound.

ST2: Play back only the sound added by Audio Dubbing

MIX: Play back both the original sound and the sound added by Audio Dubbing simultaneously.

Using a Memory Card

■ Inserting a Memory Card

Before inserting a Memory Card, be sure to turn the Palmcorder off.

- 1 Slide the [OPEN] Lever to the right and open the Card Slot Cover.
- 2 While holding the Memory Card with its cut corner facing right, insert it into the Card Slot.
- 3 Close the Card Slot Cover.

■ [ACCESS] Lamp

While the Palmcorder is accessing the Card (reading, recording, playback, erasing, moving of images), the [ACCESS] Lamp ① lights up.

- While the [ACCESS] Lamp is on, never attempt to open the Card Compartment, to pull out the Card, to turn off the Palmcorder power, or to switch the [TAPE/CARD] Selector. Such actions will damage the Card and cause the Palmcorder to malfunction.

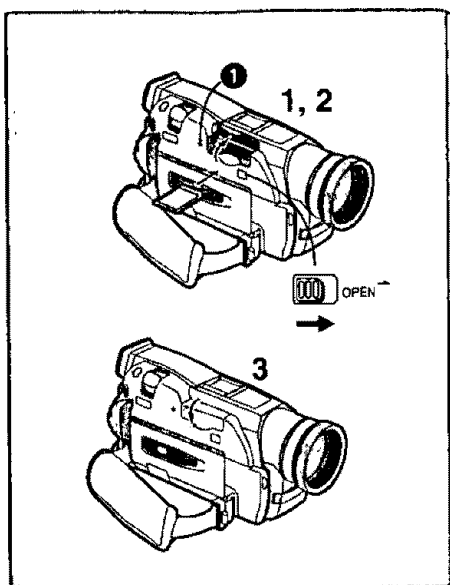

Recording on the Memory Card

Still pictures can be recorded on the Memory Card from the Palmcorder lens as well as from scenes that have already been recorded on a cassette.

The size of images that are recorded using this Palmcorder is approximately 1,080,000 pixels, and recording of images with a size that is larger than a million pixels is called mega-pixel still-picture recording (→ 53). Compared to images of normal recording, images that are created by mega-pixel still-picture recording can be printed out clearer.

■ Card Photoshot

Recording a picture through the Palmcorder lens (CAMERA Mode)

- 1 Slide the [TAPE/CARD] Selector to [CARD].
- 2 Set [PICTURE SIZE] in [CARD SETUP] Sub-Menu to [1200X900] or [640X480].
- 3 Press the [PHOTO SHOT] Button.

- The [CAMERA] Indication light in red. ①
- Mega-pixel recording (when you select [1200X900] in step 2) is useful for taking clear pictures, but the following functions are disabled during mega-pixel recording.

- Digital zooming (→ 22)
- Electronic Image stabilizer function [EIS] (→ 22)
- Digital functions (→ 26, 27)
- Title In/Creation (→ 37)

- The power is automatically turned off after about 5 minutes when a cassette has been inserted.

Recording from a cassette (VCR Mode)

- 1 Slide the [TAPE/CARD] Selector to [CARD].
- 2 Start playback and press the [PHOTO SHOT] Button at the scene you want to record.

- The size of the images input externally or recorded from a tape to the card becomes [640X480].
- While the image is being recorded, it stays still for a few seconds.
- Please refer to "Recording to a Card from other equipment" (→ 53), regarding the recording to a card from other equipment.

Selecting the quality of Card Photoshot images

- 1 Set [CAMERA FUNCTIONS] or [VCR FUNCTIONS] >> [CARD SETUP] >> [REC MODE] >> a desired image quality (FINE, NORMAL, ECONOMY).

- Please refer to page 58, concerning the Maximum Number of pictures that can be recorded on the supplied SD Memory Card.

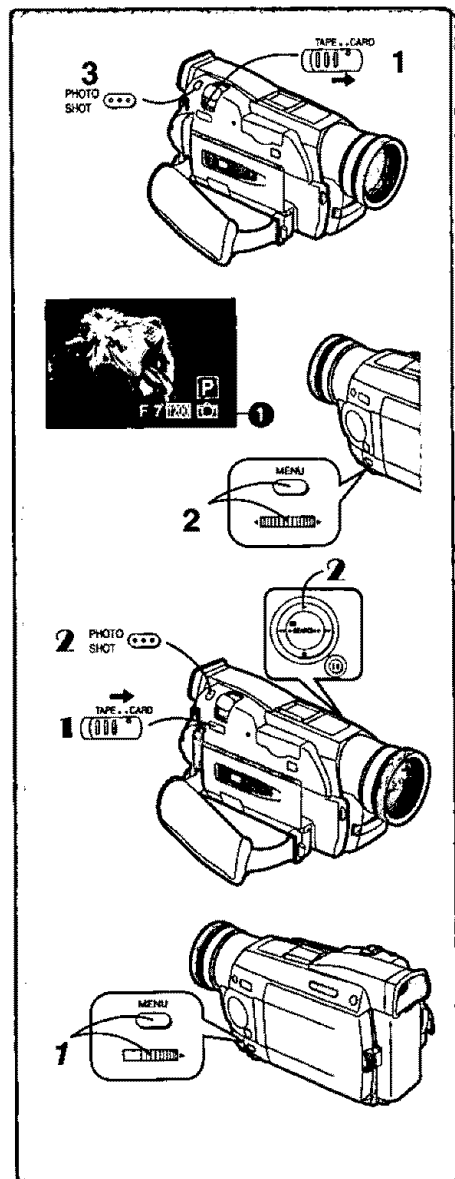

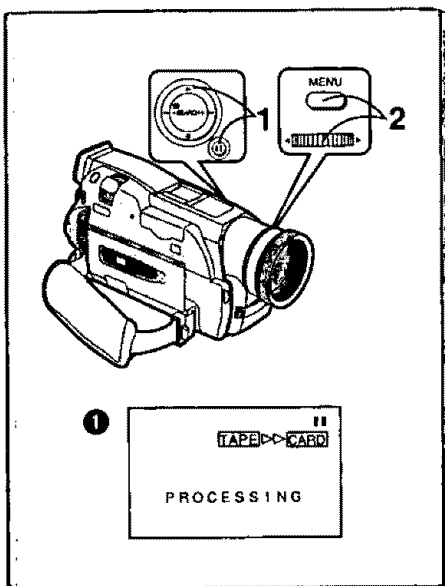

■ Automatically copying still pictures recorded on a cassette

The Palmcorder copies images automatically, referring to Photo Index signals.

After set to the VCR Mode (→ 28).....

- 1 Set the Palmcorder to Still Playback Mode just before the point where picture transfer is to commence.
- 2 Set [VCR FUNCTIONS] >> [PLAYBACK FUNCTIONS] >> [RECORD TO CARD] >> [YES].
 - Search starts from the current Cassette position, and images with Photo Index signals are recorded onto the Card sequentially.
 - While copying, the Indication ① appears.

To Stop the Transfer of Images

Press the [■] Button.

- For other notes, see page 53.

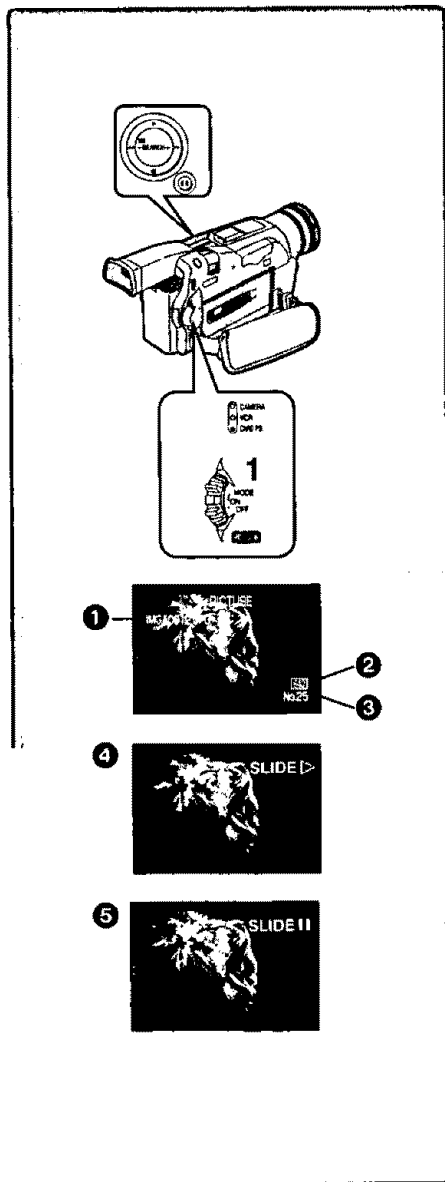

~~~~~ Playing Back Pictures on the Memory Card

- 1 Set the Palmcorder to Card Playback Mode.
 - The [CARD P.B.] Lamp lights.
 - The still picture that was recorded last on the Memory Card is displayed.

- ① File Name
- ② Picture Size (→ 49)
- ③ File Number

To play back the later recorded pictures:

Press the [SEARCH+] Button

To play back the earlier recorded pictures:

Press the [-SEARCH] Button.

■ Playing back all the pictures continuously (Slide Playback)

Press the [▶] Button.

The [SLIDE▶] Indication is displayed. ④

- All pictures are played back for approximately 5 seconds each, from the first to the last recorded picture, and the playback then stops.

To Pause the Slide Playback

Press the [||] Button.

The [SLIDE||] Indication is displayed. ⑤

- To restart slide playback, press the [||] Button again or press the [▶] Button. The slide playback starts from the next image and ends at the last displayed picture.

To Stop the Slide Playback

Press the [■] Button.

- To restart slide playback, press the [▶] Button. Slide playback starts from the next image, and, after all the recorded images are played back, slide playback stops at the image where you originally stopped slide playback.

- You can play back images with titles inserted in them. (→ 37)

However, it is not possible to display the titles or delete the displayed titles in the Slide Playback.

- When you play back the blank (not recorded) Memory Card, the screen turns white and the indication [NO PICTURE] is displayed.
- When you play back still pictures which are recorded using other formats or pictures with incomplete data, the [x] indication or the [CARD ERROR] indication may be displayed as a warning.

- For other notes, see page 53.

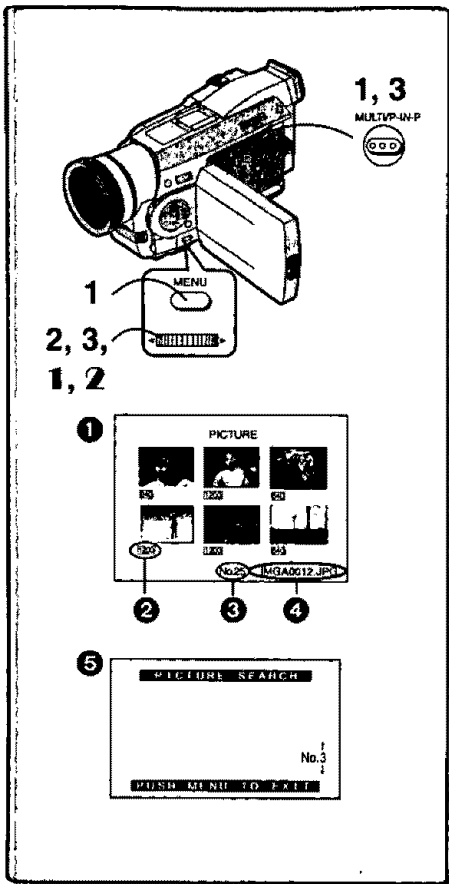

■ To Select a Desired Picture and Play it Back

After set to the Card Playback Mode (→ 35).....

- 1 Press the [MULTI] Button.
 - The still pictures recorded on the Memory Card are displayed in Multi-Picture Mode. ①
- 2 Rotate the [PUSH] Dial and select a desired picture.
 - The selected picture is marked with a red frame.
- 3 Press either the [PUSH] Dial or the [MULTI] Button.
 - The selected picture is shown on the entire screen.
 - ② Picture Size
 - ③ File Number
 - ④ File Name

■ Using Picture Search Mode

- 1 Set [CARD FUNCTIONS] >> [CARD EDITING] >> [PICTURE SEARCH] >> [YES].
 - The picture search screen ⑤ appears.
- 2 Rotate the [PUSH] Dial to select the desired number of the picture and then press it.
 - The selected number's picture appears.

• The same setting can be performed using the short-cut menu (→ 18).

• For other notes, see page 53.

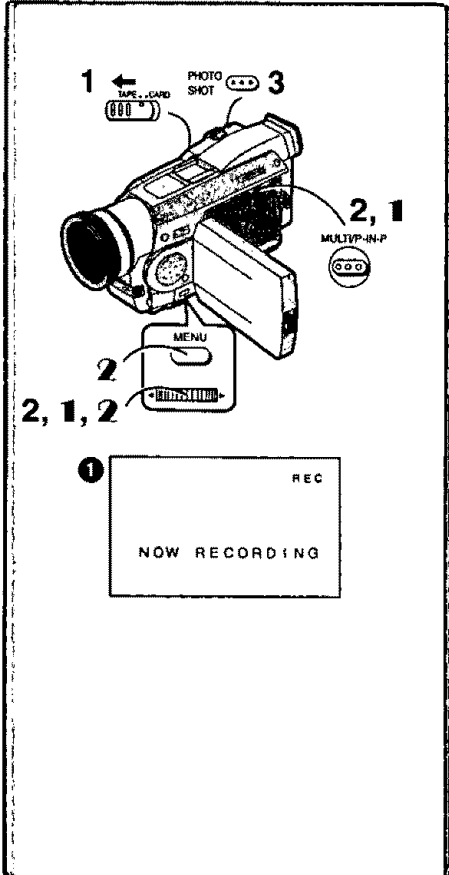

Copying pictures on a Memory Card to a Cassette

After set to the Card Playback Mode (→ 35).....

To Copy One Picture

- 1 Slide the [TAPE/CARD] Selector to [TAPE].
- 2 Display a desired picture.
 - Please refer to "To select a Desired Picture and Play it Back".
- 3 Press the [PHOTO SHOT] Button.
 - It takes approximately 7 seconds to copy a still picture to the Cassette.
 - During the copying, the Indication ① appears.

To Copy All the Pictures

- 1 Display the first picture.
 - If a picture other than the first one is displayed, only the subsequent pictures will be copied.
- 2 Set [CARD FUNCTIONS] >> [CARD EDITING] >> [RECORD TO TAPE] >> [YES].
 - It takes approximately 7-11 seconds for each picture to be copied to the Cassette. To stop the copying midway, press the [■] Button.
 - During the copying, the Indication ① appears.

• For other notes, see page 53.

Creating a Title

You can create a title and record on a Memory Card.

1 Camera Mode:

Set the Lens to the image you want to use for creating a title.

VCR Mode:

Search for the image you want to use for creating a title and set the Palmcorder to Still Playback Mode.

2 Set [CARD SETUP] >> [CREATE TITLE] >> [YES].

3 Press the [PHOTO SHOT] Button.

• To perform Photoshot again, select [RETURN].

4 Rotate the [PUSH] Dial to select [COLOR] and then press it.

5 Rotate the [PUSH] Dial to select desired color and press it.

6 Rotate the [PUSH] Dial to select [LUMINANCE] and press it.

7 Rotate the [PUSH] Dial to adjust the title contrast and then press it.

8 Select [RECORD] and then press the [PUSH] Dial.

Selecting Colors

If you make color selection by rotating the [PUSH] Dial when creating a title, you can change the color as follows.

1) Original Color (The color of the captured image)

• Title in the original color in which the dark portion (blackish portion) of the captured image is missing.

2) Preset colors (black, blue, green, cyan, red, pink, yellow, and white)

• Title in a preset color in which the dark portion (blackish portion) of the captured image is missing.

3) Original color (the color of the captured image)

• Title in the original color in which the bright portion (whitish portion) of the captured image is missing.

4) Preset colors (black, blue, green, cyan, red, pink, yellow, and white)

• Title in a preset color in which the bright portion (whitish portion) of the captured image is missing.

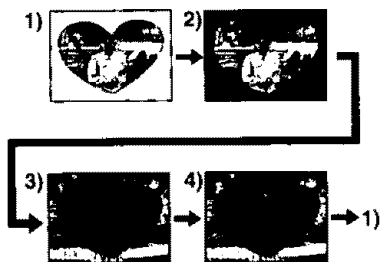
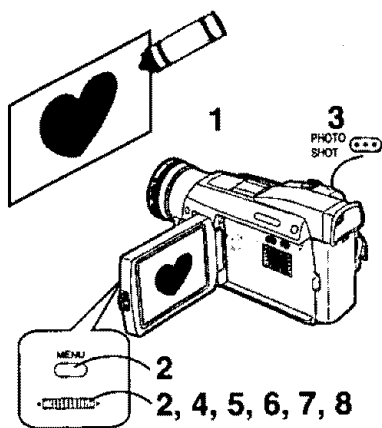

Inserting a Title

You can select one of your original titles and display it. (It can be displayed in Camera Mode, VCR Mode, and Card Playback Mode.)

1 Press the [TITLE] Button.

• The title that was created last is displayed.

2 Press [MULTI] Button.

• A list of titles is displayed.

3 Rotate the [PUSH] Dial to select a desired title.

• The selected title is marked with a red frame.

4 Press the [PUSH] Dial or press the [MULTI] Button.

• The selected title is displayed.

5 Using the [TAPE/CARD] Selector, select the recording target.

Camera Mode: TAPE or CARD

VCR Mode: CARD

Card Playback Mode: TAPE

6 Press the [PHOTO SHOT] Button.

• A still picture is recorded under the inserted title.

• If you record on a Cassette in Normal Recording Mode, set the [TAPE/CARD] Selector to [TAPE] and press the Recording Start/Stop Button.

1 File Name

Clearing a Title Display

Press the [TITLE] Button.

• For other notes, see page 53.

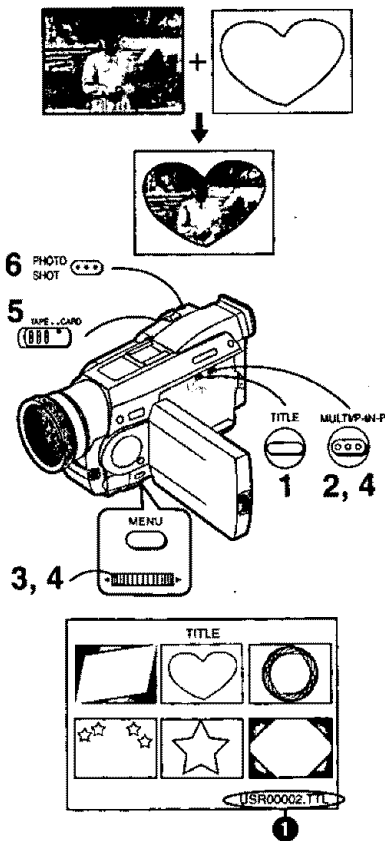

Protecting the Pictures on a Memory Card from Accidental Erasure (File Lock)

Precious pictures recorded on a Memory Card can be locked to prevent accidental erasure. (Even if pictures are locked, the pictures will be deleted when the Memory Card is formatted.)

After set to the Card Playback Mode (→ 35).....

- 1 Set [CARD FUNCTIONS] >> [CARD EDITING] >> [FILE LOCK] >> [YES].
- 2 Rotate the [PUSH] Dial to select [PICTURE] or [TITLE], and then press it.
 - The [FILE LOCK] Menu ❶ is displayed.
- 3 Rotate the [PUSH] Dial to select the picture to be locked, and then press it.
 - The [O] Indication ❷ is attached to the selected picture.
 - Press the [PUSH] Dial again to cancel.

• The same setting can be performed using the short-cut menu (→ 18).

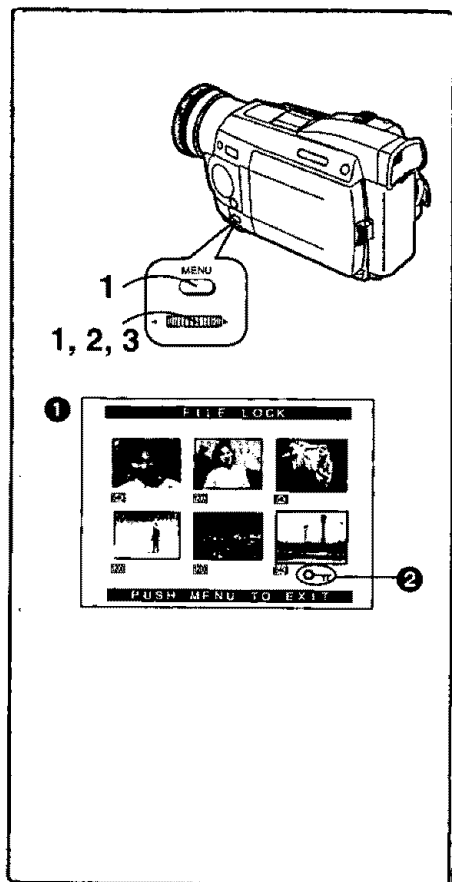

Deleting the pictures recorded on a Memory Card

Using the Palmcorder, you can delete the still pictures and titles recorded on a Memory Card. After the picture is deleted, it cannot be restored.

After set to the Card Playback Mode (→ 35).....

To Select and Delete Picture(s) by selection

- 1 Set [CARD FUNCTIONS] >> [DELETE PICTURE/TITLE] >> [DELETE PICTURE BY SELECTION] or [DELETE TITLE BY SELECTION].
- 2 Rotate the [PUSH] Dial to select the picture that you want to delete, and then press it.
 - The selected picture flashes.
 - To delete more than 1 picture, repeat this step.
- 3 Press the [PHOTO SHOT] Button.
 - A verification message appears.
- 4 Rotate the [PUSH] Dial to select [YES] and then press it.
 - The selected picture is deleted from the Memory Card.

To Delete all Pictures

- 1 Set [CARD FUNCTIONS] >> [DELETE PICTURE/TITLE] >> [DELETE ALL PICTURES].
 - A verification message appears.
- 2 Rotate the [PUSH] Dial to select [YES] and then press it.
 - All the pictures stored in the Memory Card are deleted.
 - A locked picture cannot be deleted.

• The same setting can be performed using the short-cut menu (→ 18).

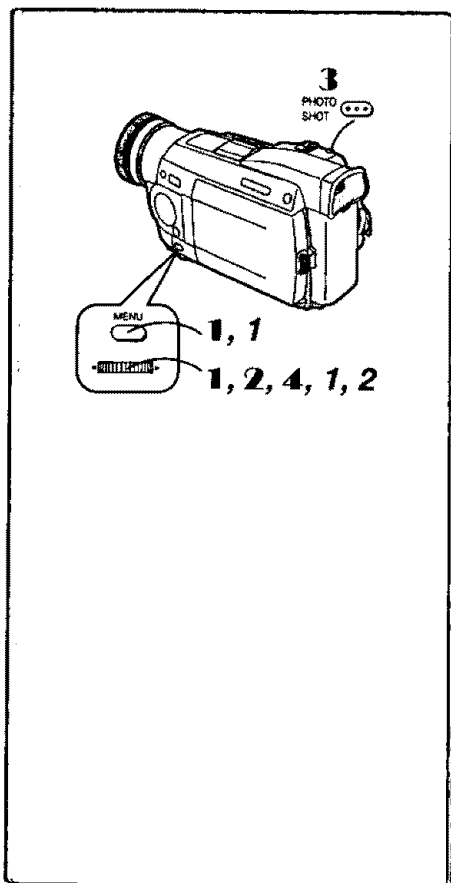

Formatting a Memory Card

If a Memory Card becomes unreadable by the Palmcorder, formatting it may make it reusable. Formatting will delete all the data recorded on a Memory Card.

After set to the Card Playback Mode (→ 35).....

1 Set [CARD FUNCTIONS] >> [CARD EDITING] >> [CARD FORMAT] >> [YES].

2 Select [YES] and press the [PUSH] Dial.

- During formatting the [PLEASE WAIT] Indication ❶ appears.
- When the formatting is completed, the screen becomes white.
- Even if pictures are locked, the pictures will be deleted when the Memory Card is formatted.

• For other notes, see page 53.

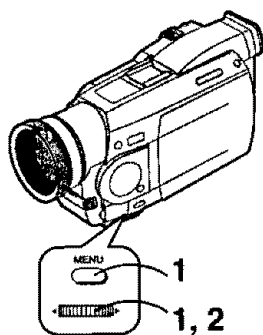

❶

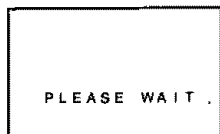

DPOF Setting

You can write the images to be printed, the number of prints, and other print-related information (DPOF setting) on a Memory Card. "DPOF" stands for Digital Print Order Format, and since printing data can be added to images on the Memory Card, the Memory Card can be used with any system that provides DPOF.

After set to the Card Playback Mode (→ 35).....

1 Set [CARD FUNCTIONS] >> [CARD EDITING] >> [DPOF SETTING] >> [YES].

2 Rotate the [PUSH] Dial to select [VARIABLE] and then press it.

3 Rotate the [PUSH] Dial to select the picture and then press it.

4 Rotate the [PUSH] Dial to set the number of prints ❶ and then press it.

- The framed images will be set to DPOF and the [●] ❷ will be displayed. The [●] mark indicate pictures for which 1 or more prints have been set.
- When printing one each of all the pictures, select [ALL 1]; if not all the pictures are printed, select [ALL 0].

5 Repeat Step 2 - 4 to set other pictures, and press the [MENU] Button when the setting is completed.

To Verify DPOF Setting

Select [VERIFY] in Step 2 above. The pictures for which one or more prints are set in DPOF are played back continuously.

-  Print mark is based on DPOF (Digital Print Order Format).
- The same setting can be performed using the short-cut menu (→ 18).
- For other notes, see page 53.

Special Features

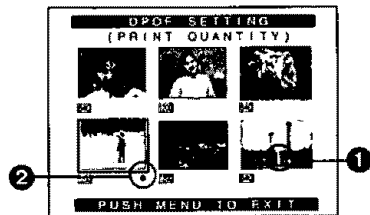
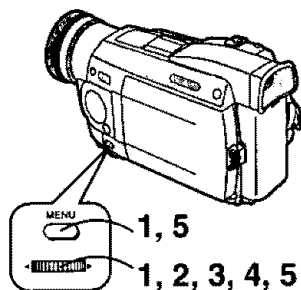

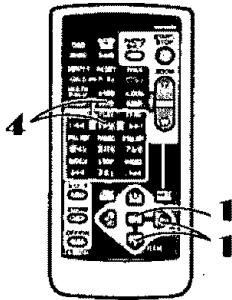
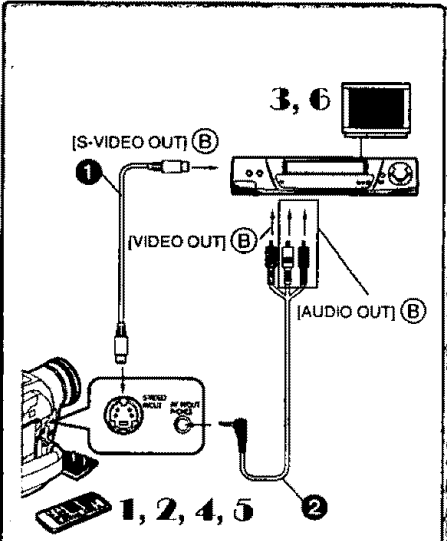
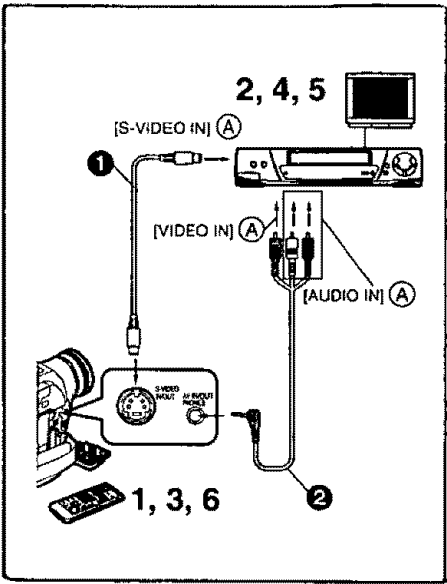

Copying your DV Cassette to an S-VHS or VHS Cassette (Dubbing)

After connecting the Palmcorder and the S-Video, Video and Audio Input Jacks (A) of the VCR as illustrated on the left, start the following procedures.

- Be sure to press the [OSD] Button on the Remote Controller before copying so that no indications are left visible. Otherwise, the displayed tape counter and Function indications are also copied.

[Palmcorder]

- 1 Insert the recorded Cassette.

[VCR]

- 2 Insert a blank Cassette with an erasure prevention tab.

- If various settings (such as external input, tape speed, etc.) are required, please refer to the operating instruction of your VCR.

[Palmcorder]

- 3 Press the [▶] Button to start playback.

[VCR]

- 4 Start recording.

- 5 Press the Pause or Stop Button to stop recording.

[Palmcorder]

- 6 Press the [■] Button to stop playback.

- ① S-VHS Cable (not supplied) ② A/V Cable (supplied)

Copying an S-VHS or VHS Cassette to your DV Cassette

After connecting the Palmcorder and the S-Video, Video, Audio Output Jacks (B) of the other equipment as illustrated on the left, start the following procedures.

- You need the Remote Controller.

[Palmcorder]

- 1 Set [VCR FUNCTIONS] >> [AV IN/OUT SETUP] >> [AV JACK] >> [IN/OUT].

- 2 Insert a blank Cassette with an erasure prevention tab.

[Other Equipment]

- 3 Insert a recorded Cassette and start playback.

[Palmcorder]

- 4 While pressing the [REC] Button, press the [PLAY] Button. (Both buttons are located on the Remote Controller.)

- 5 Press the [||] Button or [■] Button to stop recording.

[Other Equipment]

- 6 Press the Stop Button to stop playback.

- ① S-VHS Cable (not supplied) ② A/V Cable (supplied)

Analog-Digital Conversion

When the Palmcorder is connected with other digital video equipment through its DV Terminal, the analog format pictures which have been input from other external equipment can be output to the digital video equipment through the DV Terminal.

- To DV-output analog video signals sent from other equipment, set [DV OUT] on the [AV IN/OUT SETUP] Sub-Menu to [ON]. (Normally, keep the [DV OUT] set to [OFF]. If it is set to [ON], the quality of the image may be disturbed.)

CAUTION:

Unauthorized exchanging and/or copying of copyrighted recordings may be copyright infringement.

- Please refer to "Recording to a Card from other equipment" (→ 53), regarding the recording to a Card.

Using your Palmcorder with Digital Video Equipment (Dubbing)

By connecting this Palmcorder with other digital video equipment (such as another Palmcorder of the same model) that has a DV input/output terminal (i.LINK) using a DV Interface cable PV-DDC9 (optional) ①, high quality image and sounds can be dubbed in the digital mode.

[Playback Unit (A)]

1 Insert the recorded Cassette and set the Palmcorder to the VCR Mode.

[Recording Unit (B)]

2 Insert a Cassette to be used for dubbing and set the Palmcorder to the VCR mode.

[Playback Unit (A)]

3 Press the [▶] Button to start playback.

[Recording Unit (B)]

4 While pressing the [REC] Button, press the [PLAY] Button. (Both Buttons are located on the Remote Controller.)

- Recording starts.

Stopping Dubbing

Press the [■] Button on the recording unit first, and then press the [■] Button on the playback unit to stop dubbing.

CAUTION:

Unauthorized exchanging and/or copying of copyrighted recordings may be copyright infringement.

- For other notes, see page 53.

PC Connection with DV Interface Cable

A live image can be transferred directly to your Computer (personal Computer) via a DV Interface Cable (not supplied) using products and software from Digital Origin (formerly Radius), Canopus or Pinnacle. Using these products allows you to capture live images onto your Computer, edit the captured image, etc.

Note:

- For more detailed information, please visit their web site at:

<http://www.digitalorigin.com>

<http://www.justedit.com>

<http://www.pinnaclesys.com>

- Please note that Panasonic Palmcorder may not be compatible with all editing software packages. Please check with the individual software companies.

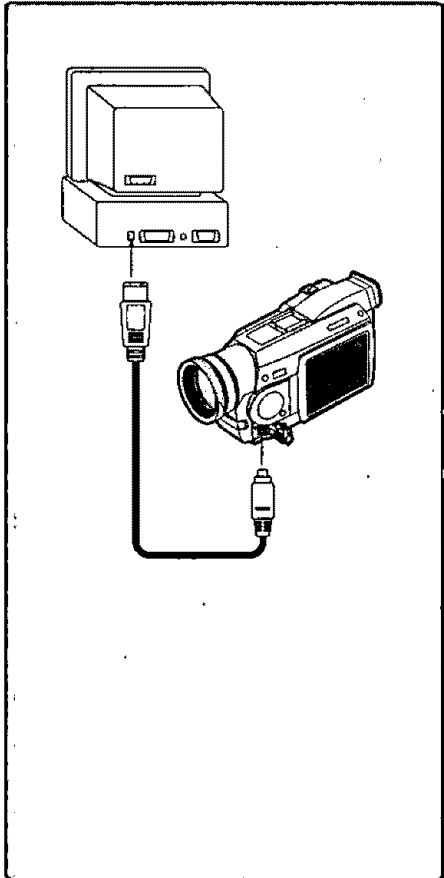
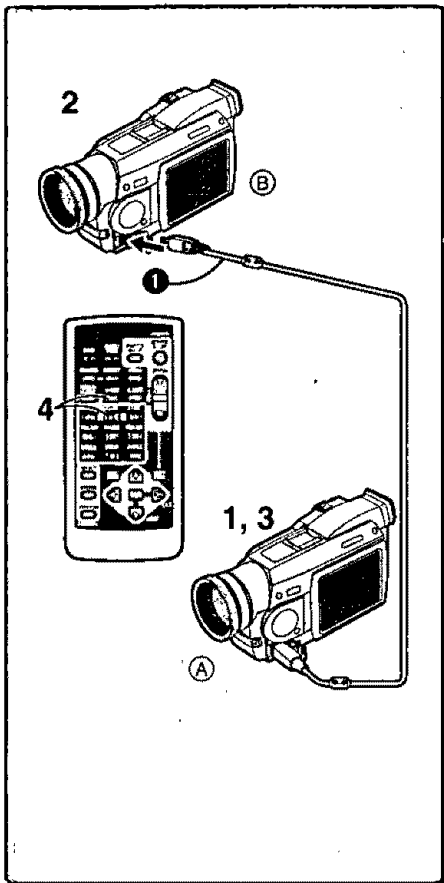

Special Features

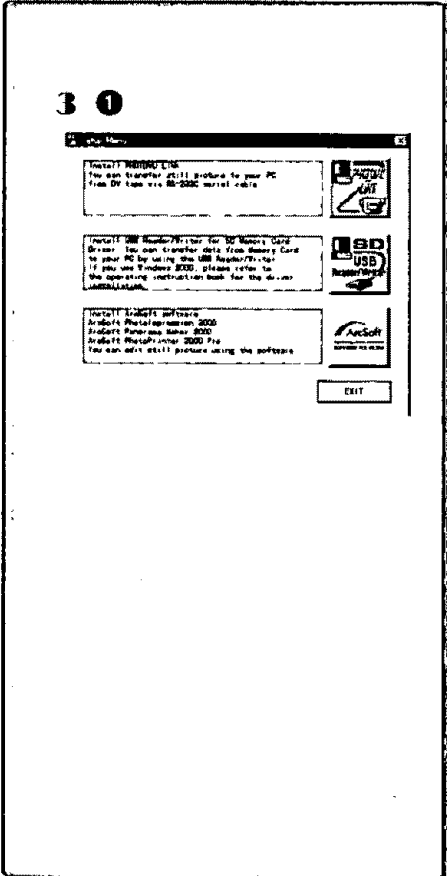
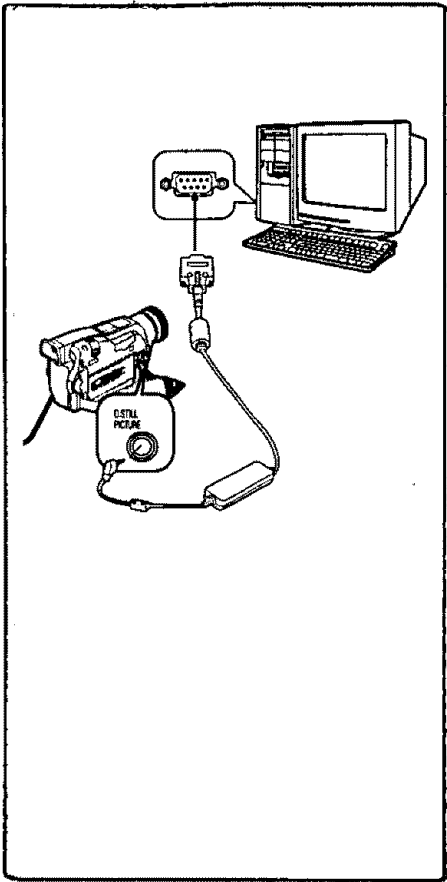

Using the Supplied Software with a Computer

An image stored in the DV Cassette can be transferred to your Personal Computer.

System Requirements for PHOTOVU LINK & ArcSoft

- IBM PC/AT or compatible.
- Intel® Pentium® Processor: 266MHz or more
- Microsoft Windows®95/98/Me, Windows®2000
- CD-ROM drive (for installation)
- Mouse or other pointing device

PHOTOVU LINK:

- RAM: 16 MB or more
- 2MB minimum available hard disk space (for installation)
- 256 color monitor (full color recommended)
- RS-232C serial port (D-Sub 9-pin). An adaptor (D-Sub 9-pin male to a D-Sub female) is required for a D-Sub 25-pin.

ArcSoft:

- RAM: 64 MB or more
- 220 MB minimum available hard disk space (for installation)
- High color (16bit) or more

USB Reader/Writer for SD Memory Card:

- Please refer to page 45, regarding the system requirements of USB Reader/Writer for SD Memory Card.

Connections

- 1 **Connect the Palmcorder to your Computer (Windows) using the RS-232C PC Connection Cable (supplied).**
 - Before connecting the Palmcorder to the Computer, make sure the Computer is off to insure that images are transferred properly.
- 2 **Turn your Computer on.**
- 3 **Set the Palmcorder to VCR Mode.**
 - For extended periods of use, it is recommended to use the AC Adaptor as a power source.
 - Refer to Computer or Windows operating instructions to identify which COM port to be used for connection.

Software Installation (Windows® 95/98/Me, Windows® 2000)

- 1 **Turn on Computer and start up Windows.**
- 2 **Insert supplied CD-ROM into the CD-ROM drive.**
 - [Setup Menu] ① appears.
- 3 **Select the software to be installed from [Setup Menu].**
 - **PHOTOVU LINK (→ 43):**
Software to transfer image from your Palmcorder to your PC.
 - **USB Reader/Writer Device Driver (→ 45, 46):**
Software for USB Reader/Writer allows you to transfer images directly off of the memory card into the computer
(Please refer to page 45 to install the driver of the USB Reader/Writer for SD Memory Card.)
 - **ArcSoft software (→ 44):**
"Panorama Maker™ 2000", "PhotoImpression™ 2000" and "PhotoPrinter® 2000 Pro" are included .
- 4 **Follow the instructions on the computer screen until the installation is complete.**
 - Setup window will disappear when the installation is complete.

Note:

If a window does not appear automatically, click the "Start" Button on your desktop and then click "Run". When the "Run" Box is open, type in "D:\InstMenu.exe" and click "OK". ("D" applies when the CD-ROM drive is drive D.)

PHOTOVU LINK

You can transfer images from your Palmcorder Cassette to a Computer.

1

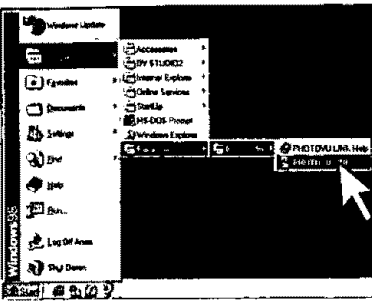

Before you begin....

- Insert the recorded Cassette. (→ 13)
- Make Palmcorder-Computer connections. (→ 42)
- Turn your Computer on.
- Set Palmcorder to VCR Mode.

Running the Software

- 1 Click [Start] >> [Programs] >> [panasonic] >> [Palmcorder]>> [PHOTOVU LINK].
 - [PHOTOVU LINK] is opened.

Note

COM Port and Baudrate are automatically selected.

Refer to Help for information about application operations and other error messages.

3

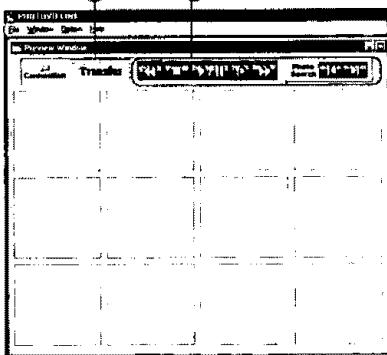

Using Tape Image Data

An image stored in the DV Cassette can be transferred directly to your Computer via an RS-232C connection.

- 1 Open the [PHOTOVU LINK].
 - [Preview window] screen appears.
- 2 Search and Select a video footage or a scene you want to transfer to your Computer using VCR Operation Buttons 1 on the [Preview window] screen.
- 3 Click [Transfer] 2 during Playback Mode or still Playback Mode.
- 4 Click [File] and then [Save As] to save transferred image.

Note

- If, while transferring the image to your Computer, the displayed picture appears abnormal, close [PHOTOVU LINK] and turn Palmcorder off, and then turn the Palmcorder on and restart [PHOTOVU LINK].
- Photo Search may fail to detect a recorded Photoshot image if the image is 3 seconds or less.

4

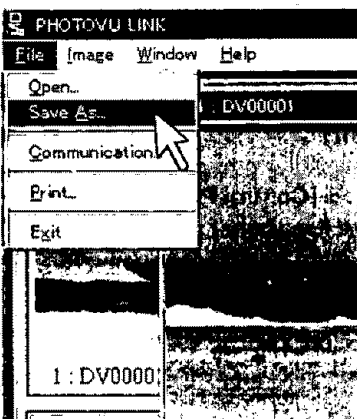

ArcSoft Software

There are 3 types of image editing software in the ArcSoft Software.

Before you begin...

- 1 Open [Start] >> [Programs] >> [ArcSoft] >> [Panorama Maker 2000] or [Photolmpression 2000] or [PhotoPrinter 2000 Pro].

1 Panorama Maker 2000

- Easy-to-use photo-stitching program seamlessly combines multiple photos into a single panoramic picture.

2 Photolmpression 2000

- Easy-to-use photo editing program to edit, enhance, retouch or add special effects to any image. Also offers creative solutions for making greeting cards and calendars.

3 PhotoPrinter 2000 Pro

- Program to layout images in multiple sizes quickly and effortlessly to create a collage or photo album, all on one page.

For Information on ArcSoft Software:

TEL: 1-510-440-9901
FAX: 1-510-440-1270
Web Site: www.arcsoft.com
E-mail: support@arcsoft.com

Refer to Help information about application operations and other Error messages.

Uninstalling Application Software (PHOTOVU LINK, ArcSoft)

- 1 Click [Start] >> [Settings] >> [Control Panel]. ①
- 2 Double Click [Add/Remove Programs] in [Control Panel].
- 3 Select the application software you want to remove.

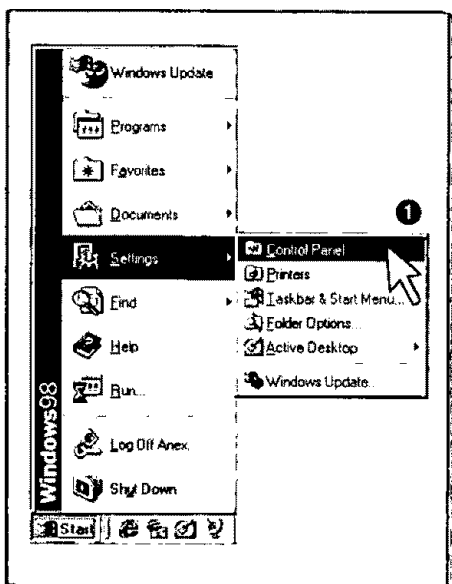
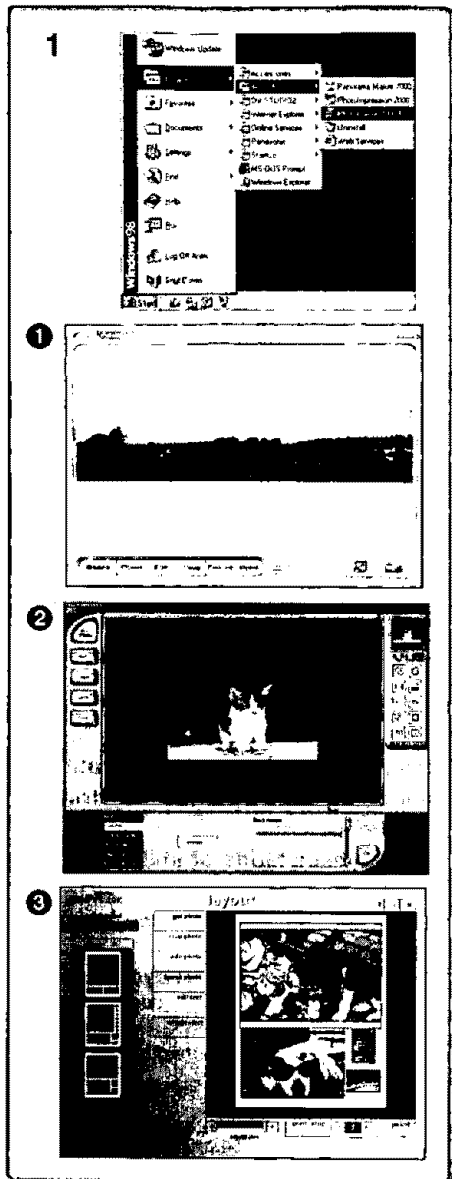

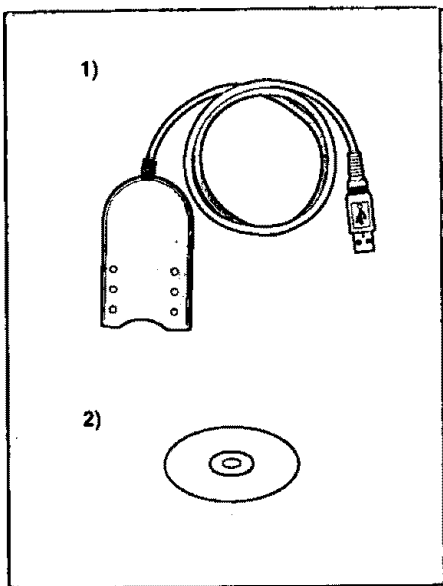

Using the Supplied USB Reader/Writer for SD Memory Card

Using the supplied USB Reader/Writer for SD Memory Card lets you import the still pictures recorded on the MultiMediaCard or SD Memory Card with ease into a computer.

Supplied Accessories

- 1) USB Reader/Writer for SD Memory Card
- 2) CD-ROM

Computer System Requirements

- This Software can be installed in PC/AT compatible personal computers with Microsoft® Windows® 98/Me, Windows® 2000 preinstalled and equipped with a USB port.

Disk Drive: CD-ROM drive

Port: USB

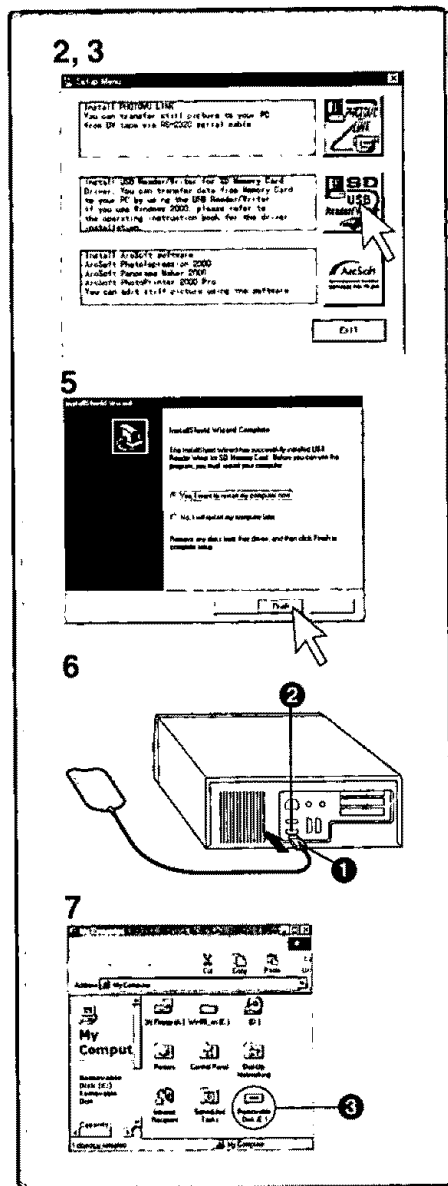

Installing the driver of the USB Reader/Writer for SD Memory Card (Windows® 98/Me)

- For users using Windows® 2000, please refer to page 46 regarding to installation.

Start the following installation procedure **without** inserting the USB Reader/Writer for SD Memory Card into the USB port on the computer. Otherwise Windows installer will start and the installation process will not be completed successfully.

- In the case of inserting the USB Reader/Writer for SD Memory Card into the Computer by mistake, remove the USB Reader/Writer for SD Memory Card first, and then proceed with the following operations.

- 1 Turn on the power of the computer, and start Windows.
- 2 Insert the supplied CD-ROM into the CD-ROM drive.
 - [Setup Menu] appears.
- 3 Click the [USB Reader/Writer] icon on the [Setup Menu].
- 4 Select [English] on the [Choose Setup Language] window, and click [OK].

The [InstallShield Wizard] window now appears, and the installation commences. Follow the on-screen instructions to complete the installation procedure.

- 5 When the message indicating that the installation has been completed appears, click [Finish], and re-start the computer.

- 6 Plug the USB Reader/Writer for SD Memory Card's connector ① into the USB port ② on the computer.

The [New Hardware Found] window appears, and the driver is registered automatically.

- 7 Open [My Computer] or [Windows Explorer] etc., to check the drive is displayed as a removable disk drive ③.

Note:

If a window does not appear automatically, click the "Start" Button on your desktop and then click "Run". When the "Run" Box is open, type in "D:\InstMenu.exe" and click "OK". ("D" applies when the CD-ROM drive is drive D.)

When the Installation is not successful:

Remove the USB Reader/Writer for SD Memory Card from the computer first, and then proceed with the above operations again.

■ Installing the driver of the USB Reader/Writer for SD Memory Card (Windows® 2000)

- 1 Turn on the power of the computer, and start Windows.
- 2 Insert the supplied CD-ROM into the CD-ROM drive, and then click [EXIT] after the menu Window appears.
 - It takes the computer several seconds to recognize the CD-ROM.
- 3 Plug the USB Reader/Writer for SD Memory Card's connector ① into the USB port ② on the computer.
 - The [Add New Hardware Wizard] window appears when the USB Reader/Writer for SD Memory Card has been connected to the computer for the first time.
- 4 Click [Next].
- 5 To select the search method, select [Search for a suitable driver for my device (recommended).] and click [Next].
- 6 Select the [CD-ROM Drives] and click [Next].
- 7 After checking that the file name is "sdca2k.inf" ③, click [Next].
- 8 When a display appears to indicate that the USB Reader/Writer for SD Memory Card has been installed, click [Finish].
- 9 Open [My Computer] or [Windows Explorer] etc., to check the drive is displayed as a removable disk drive ④.

■ Inserting the Memory Card into the USB Reader/Writer for SD Memory Card

Hold the Memory Card with its label facing upward and the cut-off corner to the right ⑤, and insert it into the Card Slot.

- Do not remove the Memory Card while the [ACCESS] lamp ⑥ lights.
- Be sure to insert the Memory Card all the way into the USB Reader/Writer for SD Memory Card until it stops.
- Forcefully inserting the Memory Card in the wrong direction may damage the USB Reader/Writer for SD Memory Card and/or the Memory Card.

■ Operations on the Computer

When the Memory Card is inserted, the USB Reader/Writer for SD Memory Card operates like a floppy disk drive, and you can use the same drag and drop or copy methods.

- If the computer has been connected via two or more USB cables or if another dedicated adaptor has been connected to the USB Reader/Writer for SD Memory Card, operation may not be performed properly.
- If you are using a notebook computer, be sure to connect its AC adaptor.

■ Image Data on the Memory Card

If you double click the Removable Disk icon ④, the folders are displayed. (Dcim\100cdpfp) The Image Data recorded by this Palmcorder is JPEG Format. (Example: Imga0001.jpg)

- If you change the file name, it may not be possible to play back the corresponding picture(s) on the Palmcorder.
- Pictures that you have edited or composed on a computer can be saved on the Memory Card, however, they may not be played back on the Palmcorder.

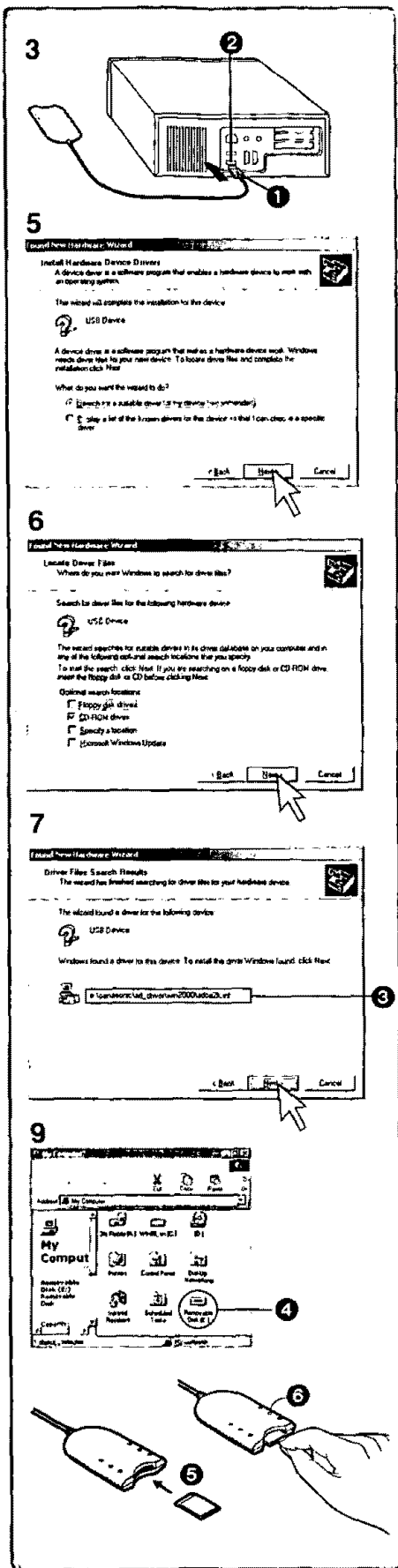

■ To remove the USB Reader/Writer for SD Memory Card (Windows® 98/Me)

- 1 Close the software program that is using the USB Reader/Writer for SD Memory Card.
- 2 Check to see the access lamp on the USB Reader/Writer for SD Memory Card is off, and then remove the SD Memory Card.

■ To remove the USB Reader/Writer for SD Memory Card (Windows® 2000)

- 1 Close the software program that is using the USB Reader/Writer for SD Memory Card.
- 2 Click the card icon displayed in the system tray on the lower right of the screen.
- 3 Select "Stop USB Reader/Writer for SD Memory Card" and click it.
- 4 Check to see the access lamp on the USB Reader/Writer for SD Memory Card is off, and then remove the SD Memory Card.

■ Cautions

- Do not subject the USB Reader/Writer for SD Memory Card to shocks.
- Do not insert any objects except Memory Cards; otherwise it could damage the USB Reader/Writer for SD Memory Card and the connected equipment.
- Keep the USB Reader/Writer for SD Memory Card away from high-temperature locations and direct sunlight.
- Do not attempt to disassemble or remodel the USB Reader/Writer for SD Memory Card.
- Operation may not or will not be performed properly when it is connected simultaneously with other USB equipments (or using USB hub or USB extension cord).
- Note that operations are not guaranteed for all Computers providing the recommended environment.
- Note that after you have edited or modified images in your personal computer, you may not be able to play back images in Palmcorder.

■ Concerning the SD Memory Card and MultiMediaCard

SD Memory Card

The SD Memory Card (supplied) is the same size as a MultiMediaCard. It is an external memory card that is available in larger capacities. It has a write protect switch to prevent data writing and card formatting, as well as a copyright protection function.

- SD Logo is a trademark.

MultiMediaCard

The MultiMediaCard is a compact, lightweight and removable external memory card.

- All other company and product names in the operating instructions are trademarks or registered trademarks of their respective corporations.

Still pictures recorded on a SD Memory Card or MultiMediaCard

It may not be possible to play back the pictures on this Palmcorder recorded on and created by other equipment or vice versa. For this reason, check the compatibility of the equipment in advance.

■ Concerning the compatibility of the card images

Image data files recorded on "SD Memory Card"s or "MultiMediaCard"s by this Palmcorder conform with DCF (Design Rules for Camera Files Systems universal standard) established by JEIDA (Japan Electronic Industry Development Association).

- If you attempt to play back images recorded with this Palmcorder in other equipment or to play back images recorded with other equipment in this Palmcorder, you may not be able to play them back. Please check the compatibility with other equipment in advance.

■ Concerning the folder structure when using the Memory Card in a personal computer

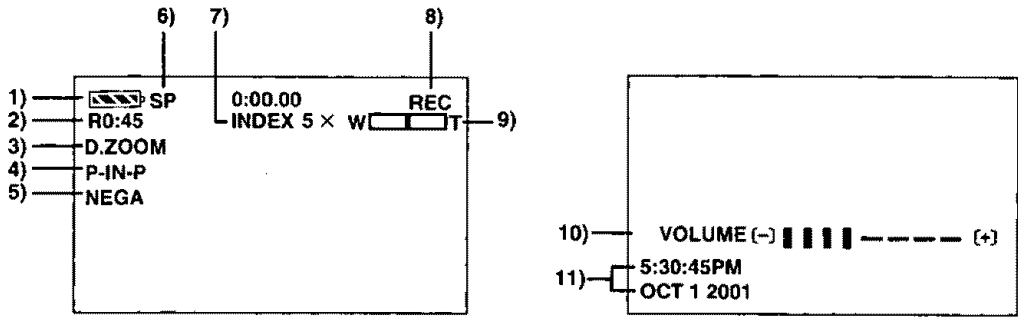

- If you insert a memory card in your personal computer, the folder should be displayed as below.
 - [100cdpfp]: The images in this folder (Imga0001.jpg etc.) have been recorded in JPEG format.
 - [Misc]: This folder contains files which set up in DPOF data
 - [Title]: This folder contains data of original titles (Usr00001.jpg, Usr00001.ttl etc.)
- [Dcim], [Im01cdpfp], [Private], [Vtf] are necessary items for the folder structure. In actual use you do not have to be concerned about them.
- In the Card Photoshot Mode, the palmcorder automatically saves the image under a file name (Imga0001.jpg etc.) File names are recorded with each picture as running numbers.



Indications

Various functions and Palmcorder conditions are displayed on the screen.

1) Remaining Battery Power []

- When the battery power becomes low, the indication changes. When the battery is discharged completely, the  () Indication flashes.
- When you are using the AC Adaptor, the  Indication may appear, however, this has no meaning in this case.

2) Remaining Tape Time [R0:00]

- Remaining tape time is indicated in minutes. When it reaches less than 3 minutes, the indication starts flashing.

3) Digital Zoom [D.ZOOM] (→ 22) Playback Zoom [ZOOM 5x] (→ 31)

4) Digital Effects 1

- MULTI: Multi-Picture Mode (→ 27, 32, 36, 37)
- P-IN-P: Picture-in-Picture Mode (→ 27)
- WIPE: Wipe Mode (→ 26, 31)
- MIX: Mix Mode (→ 26, 31)
- STROBE: Strobe Mode (→ 26)
- GAIN-UP: Gain-up Mode (→ 26)
- TRAIL: Trailing Effect Mode (→ 26)
- MOSAIC: Mosaic Mode (→ 26)
- MIRROR: Mirror Mode (→ 26)

5) Digital Effects 2

- NEGA: Negative Mode (→ 26)
- SEPIA: Sepia Mode (→ 26)
- MONO: Black & White Mode (→ 26)
- SOLARI: Solarization Mode (→ 26)

6) Recording Speed Mode

- SP: Standard Play Mode (→ 19)
- LP: Long Play Mode (→ 19)

7) Index

- For several seconds while index signals are being recorded, the [INDEX] Indication flashes. (→ 30)
- Search Number [S1] (→ 30)**
- The figure indicates which number of scene ahead from the present scene is to be played back.

8) Tape Run Indications

- REC: Recording (→ 20)
- PAUSE: Recording Paused (→ 20)
- ▷: Playback/Camera Search in forward direction (→ 20, 28)
- ◁: Camera Search in reverse direction (→ 20)
- III: Still Playback (→ 29)
- ▷▷: Fast-forward/Cue Playback (→ 28)
- ◁◁: Rewind/Review Playback (→ 28)
- |▷: Slow Playback in forward direction (→ 29)
- ◁|: Slow Playback in reverse direction (→ 29)
- III▷: Still Advance Playback in forward direction (→ 29)
- ◁III: Still Advance Playback in reverse direction (→ 29)
- ▷▷◁: Index Search in forward direction (→ 30)
- ◁◁▷: Index Search in reverse direction (→ 30)
- CHK: Recording Check (→ 20)
- A.DUB ▷: Audio Dubbing (→ 33)
- A.DUB III: Audio Dubbing Pause (→ 33)
- PHOTO: Photoshot Mode Recording (→ 21)
- BLANK: Blank Search (→ 29)
- R ▷: Repeat Playback (→ 28)
- 2x ▷▷: Variable Speed Search (→ 28)

9) Zoom Magnification

- When the [W/T] Zoom Lever is pushed up or down, the Zoom Magnification Indication and Zoom Gauge appear. (→ 21, 22)

10) Sound Volume

- Use this indication to adjust the volume of playback sound from the built-in speaker or headphones. (→ 28)

11) Date/Time Indication [5:30:45PM / OCT 1 2001] (→ 19)

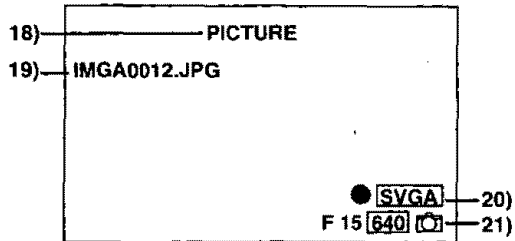
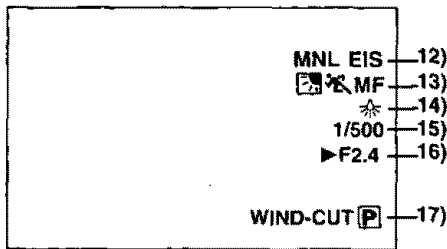

12) Recording Mode

- **AUTO:** This appears when Mode Selector Switch is set to [AUTO]. (→ 20)
- **MNL:** This appears when Mode Selector Switch is set to [MANUAL]. (→ 23, 24, 25)

- **Electronic Image Stabilizer [EIS]** (→ 22)
- **Audio Dubbing Input Display [MIC/AV IN]** (→ 33)
- **Audio Recording Mode [12bit/16bit]** (→ 33)

13) Manual Focus [MF] (→ 24)

- **Back Light Mode** [] (→ 23)

Program AE Mode

- [] : Sports Mode (→ 23)
- [] : Portrait Mode (→ 23)
- [] : Low Light Mode (→ 23)
- [] : Spotlight Mode (→ 23)
- [] : Surf & Snow Mode (→ 23)

14) White Balance Mode

- **AWB:** Automatic White Balance Mode (→ 25)
- [] : Last manually adjusted White Balance setting (→ 25)
- [] : Fluorescent light Mode (→ 25)
- [] : Outdoor Mode (→ 25)
- [] : Indoor Mode (recording under incandescent lamp) (→ 25)

15) Shutter Speed [1/500] (→ 24)

16) Iris Value [F2.4] (F number) (→ 24)

17) Wind Noise Reduction [WIND-CUT] (→ 16) Progressive Photoshot Mode [P] (→ 21)

18) File Type Display [PICTURE/TITLE] (→ 35, 37)

19) File Name Display (→ 35, 36, 37)

20) Card Picture Indications 1

- **DPOF setting (setting for more than 1 print) [●]** (→ 39)
- **Number set DPOF [00]** (→ 39)
- **Image size [640/1200]** (→ 34, 35)

When you playback a scene recorded on a Palmcorder with a picture size specification different from the one stated above, the following indications should be displayed. If the size of the picture is from 640 pixels to 800 pixels, the [640] indication will be displayed; if picture size is 640 pixels or lower, the scene should be displayed without any indication of picture size.

- **[SVGA]** : From 800 to 1024 pixels
- **[XGA]** : From 1024 to 1280 pixels
- **[SXGA]** : From 1280 to 1600 pixels
- **[UXGA]** : Above 1600 pixels

21) Card Picture Indications 2

- **Card Photoshot picture quality [N/F/E]** (→ 34)
(Card Photoshot Recording) [F] is Fine, [N] is Normal, [E] is Economy in abbreviated terms.
- **Recording in Card Photoshot [] (red)** (→ 34)
- **Memory Card is not inserted [] (→ 34)**
- **Card Photoshot is ready to record [] (cyan)** (→ 34)
- **Picture number [No.000]** (→ 35)
- **Remaining number of Card Photoshot Picture [000]** (→ 34)
- **Lock setting [] (→ 38)**

■ Changing the Counter Display Mode

By changing [C.DISPLAY] on the [DISPLAY SETUP] Sub-Menu, you can change the Counter Display Mode to Tape Counter Indication (0:00.00), Memory Counter Indication (M0:00.00), and Time Code Indication (0h00m00s00f).

● You also can press the [COUNTER] Button of the Remote Controller repeatedly to change the Counter Indication.

■ Displaying Date/Time Indication

To display Date/Time Indication, set the appropriate date/time in [DATE/TIME] on the [DISPLAY SETUP] Sub-Menu.

● You also can press the [DATE/TIME] Button of the Remote Controller repeatedly to display or change the Date/Time Indication.

■ Changing the Display Mode

By changing [DiSPLAY] on the [DISPLAY SETUP] Sub-Menu, Counter Display Mode changes to All Function Display, Partial Display, and Minimum Display.

Warning/Alarm Indications

If any one of the following indications lights up or flashes, please check the condition of the Palmcorder.

DEW DETECTED: Condensation has occurred. (→ 55)

EJECT TAPE: After the [DEW DETECTED] Indication appears, eject the Cassette.

 **CHECK REC TAB :** The erasure prevention tab on the inserted Cassette is open (that is, set to [SAVE]).

 **CANNOT REC :** When you are attempting to do audio dubbing on the unrecorded (blank) portion of the tape, or you are attempting to do dubbing (→ 33, 40, 41) on the Cassette whose tab is set at [SAVE].

 **TAPE NOT INSERTED:** No Cassette is inserted. (→ 13)

 **LOW BATTERY:** The Battery is low. Recharge it. (→ 12)

 **:** The internal lithium battery is low. (→ 19)

 **NEED HEAD CLEANING:** The video heads are dirty.

 **END/TAPE END:** The tape came to end during recording.

REMOTE/

CHECK REMOTE MODE:

Wrong Remote Controller Mode has been selected. (→ 11)

CANNOT REC LP-MODE:

Because the original recording was done in LP Mode, audio dubbing cannot be performed. (→ 33)

INCOMPATIBLE DATA: This Cassette is incompatible or containing copy-guard.

Because the medium is protected by a copy guard, images cannot be recorded correctly.

 **:** If this Indication appears, return the LCD Monitor to the original position in order to check the specific content of the Warning/Alarm Indication.

AV INPUT RECORDING:

When you are attempting to record on the Memory Card during dubbing (→ 40, 41) on the Cassette.

NO CARD:

There is no Memory Card inserted.

PLEASE WAIT:

When reading of the Memory Card (playback, format, when using the Multi-Picture Function). (→ 35, 39)

CARD ERROR:

The Memory Card is not compatible with the Palmcorder.

CARD DOOR OPENED:

Card Slot Cover is opened. After insert the Memory Card correctly, close the Card Slot Cover.

CHANGE TO TAPE MODE:

When you are attempting to record on the Memory Card in the Card Playback Mode. Change to the VCR Mode or slide the [TAPE/CARD] Selector to [TAPE].

CHANGE TO CARD MODE:

When you are attempting to record on the Cassette in the VCR Mode. Change to the Card Playback Mode or slide the [TAPE/CARD] Selector to [CARD].

FILE LOCKED:

When you are attempting to delete a locked picture. The locked picture cannot be deleted.

WRITE PROTECTED:

When you are attempting to write the data on an SD Memory Card whose write protection switch is set at [LOCK].

NO PICTURE:

There are no pictures in the Memory Card.

NO TITLE:

There are no titles in the Memory Card.

NO SPACE LEFT:

When a still Picture is transferred from a Cassette to an already full Memory Card.

CHANGE TO 640×480: Titles cannot be displayed.

(→ 37) Set to the [640×480].

X:

Pictures of a different format or damaged pictures are being played back. (→ 35)

Notes & Precautions

Power-Related Items (→ 21)

- When the Palmcorder is used for a long time, the Camera body becomes warm, but this is not a malfunction.
- If the [CHARGE] Lamp does not light up although the Battery is attached, detach the Battery and reattach it.

Inserting/Ejecting the Cassette (→ 13)

- In the case of using a previously recorded Cassette, you can use the Camera Search Function to find the position where you want to continue recording.
- If a new Cassette is inserted, rewind to the beginning of the tape before starting recording.

If the Cassette Holder Does Not Go Back in:

- Press the [PUSH TO CLOSE] mark and close the Upper Cassette Compartment Cover firmly.
- Turn off the Palmcorder and then turn it on again.
- Check if the Battery charge is low.

If the Cassette Holder Does Not Come Out:

- Close the Lower Cassette Compartment Cover completely. Then, open it again.
- Check if the Battery is weak.

Recording (→ 20)

- Before turning on the Palmcorder, remove the Lens Cap. If the lens cap is still attached when the Palmcorder is turned on, Automatic White Balance Adjustment may not function correctly.

Recording Check (→ 20)

- For recording check, the Palmcorder must be the same as the recording speed Modes (SP/LP) used for the recording. Otherwise the playback images will be distorted.

Camera Search (→ 20)

- In Camera Search Mode, images may contain mosaic-like noise patterns. This is a phenomenon that is characteristic of digital video and not a malfunction.
- If the recording speed Modes (SP/LP) of previous recording and new recording are different, playback images may be distorted.

Progressive Photoshot Function (→ 21)

- When you change to the still picture Mode, you will hear a click. This is the sound of the iris closing and not an indication of malfunction.
- If you record still pictures in Progressive Photoshot Mode when your Palmcorder is set to Program AE, the brightness of the images may vary.

About [PROGRESSIVE] Setting

- When the [P] Indication is displayed, you can use the Progressive Photoshot Function.

When [PROGRESSIVE] is set to [ON]:

You can use the Progressive Photoshot Function at any time. In this case, however, the following functions are disabled.

- [EFFECT1] Digital Effect Modes
- Digital Zoom [D.ZOOM]
- 1/750 or faster shutter speed
- Continuous Photoshot Function

When [PROGRESSIVE] is set to [AUTO]

You cannot use the Progressive Photoshot Function in the following circumstances.

- When the zoom magnification is approximately 10 X or higher
- When the shutter speed is 1/750 or faster
- When [EFFECT1] is set to [WIPE][MIX][STROBE][GAIN-UP][TRAIL][MOSAIC][MIRROR]

- When the pictures are displayed on a Multi screen or P-IN-P screen
- Continuous Photoshot Function

Zoom In/Out Functions (→ 21, 22)

- By pressing the [W/T] zoom lever to [W] or to [T] in Recording Pause Mode, you can zoom 1-10 X at the maximum speed of 0.3 seconds.
- During recording, you can zoom 1-10 X in as short a time as approximately 0.8 seconds.
- During considerably fast zooming, the image may become out of focus temporarily.
- When you are zooming on a faraway subject, a sharper focus is achieved if the recording subject is 4 feet (1.2 m) or more away from the Palmcorder.

Electronic Image Stabilizer Function (→ 22)

- Under conditions of dim lighting, the Electronic Image Stabilizer Function will not operate correctly. In such case, the [EIS] Indication will flash.
- Under fluorescent lighting, image brightness may change or colors may not look natural.
- After-images may appear.
- We recommend that you turn off the Image Stabilizer Function when a Tripod is in use.
- By setting [EFFECT1] on the [DIGITAL EFFECT] Sub-Menu to [GAIN-UP], you can disable the Image Stabilizer Function.
- When mega-pixel recording is set, the Image Stabilizer Function cannot be used.

Fade In/Out Mode (→ 22)

Fading-in and fading-out cannot be used when recording still pictures in the Photoshot Mode, Digital Still picture Mode, Multi-Picture Mode, and for the small still picture in the Picture-in-Picture Mode.

Program AE (→ 23)

- If any of the Program AE Modes is selected, you cannot adjust the shutter speed or iris.
- You cannot use Program AE with Gain-up Mode [GAIN-UP].

Sports Mode

- During normal playback, the image movement may not look smooth.
- Because the color and brightness of the playback image may change, avoid recording under fluorescent light, mercury light, or sodium light.
- If you record a subject illuminated with strong light or a highly reflective subject, vertical lines of light may appear.
- If the light is insufficient, the [] Indication flashes.

Sports Mode/Portrait Mode

- If you record a still picture in Progressive Photoshot Mode, the brightness of the recorded still picture may become unstable.
- If these modes are used for indoor recording, playback images may flicker.

Low Light Mode

- Extremely dark scenes may not be able to be made brighter to a satisfactory degree.

Spotlight Mode

- With this Mode, recorded images may turn out to be extremely dark.
- If the recording subject is extremely bright, its recorded image may turn out to be whitish.

Surf & Snow Mode

- If the recording subject is extremely bright, its recorded image may turn out to be whitish.

Manual Shutter Speed Adjustment (→ 24)

- You may see vertical lines of light in the playback image of a brightly shining subject or highly reflective subject.
- During Normal Playback, transition from one scene to another may not look smooth.
- Because the color and brightness of the playback image may become unstable, avoid recording under fluorescent light, mercury light, or sodium light.
- If you are using either Gain-up Mode or Program AE Mode, you cannot adjust the shutter speed. If the shutter speed is adjusted manually, this setting will be cancelled.

Manual Iris Adjustment (→ 24)

- Depending on zoom magnification, the iris value may not be displayed correctly.
- If you are using either Gain-up Mode or Program AE Mode, you cannot adjust the iris. If the iris is adjusted manually, those Modes will be cancelled.

White Balance (→ 25)

- You cannot change White Balance if you set [EFFECT1] of [DIGITAL EFFECT] Sub-Menu on the [CAMERA FUNCTIONS] Main-Menu to [GAIN-UP] or [EFFECT2] to [SEPIA] or to [MONO].
- In addition, when you set the Zoom to 10 X or higher, you cannot change White Balance.

In the following cases, the [] Indication flashes:

- The flashing indicates that the previously adjusted White Balance setting is still kept. This setting will be kept until White Balance is adjusted again.
- You may not be able to achieve correct White Balance adjustment manually under weak illumination.

Digital Effect Functions (Camera Mode) (→ 26)

- If you set [EFFECT1] on [DIGITAL EFFECT] Sub-Menu to [GAIN-UP], you need to adjust the focus manually. However, you cannot adjust the shutter speed and iris and cannot select White Balance.
- If [EFFECT2] on the [DIGITAL EFFECT] Sub-Menu is set to [MONO] or [SEPIA], the selected White Balance Mode cannot be changed.
- You cannot use Program AE with Gain-up Mode [GAIN-UP].
- When [PROGRESSIVE] on the [CAMERA SETUP] Sub-Menu is set to [ON], it is not possible to use any of the digital modes in [EFFECT1] on the [DIGITAL EFFECT] Sub-Menu.

Wipe Mode and Mix Mode (Camera Mode) (→ 26)

If either one of the following operations is carried out, stored images will be erased, and Wipe and Mix Functions cannot be used.

- Use the Camera Search Function
- Press the [CAMERA STILL] Button
- Switch the [TAPE/CARD] Selector.

Multi-Picture Mode (Camera Mode) (→ 27)

- When [PROGRESSIVE] on the [CAMERA SETUP] Sub-Menu is [ON], Multi Mode cannot be used.
- If the [MULTI] Button is pressed while self-recording Mirror mode (→ 20) is used, the still picture is displayed from the upper right corner of the screen, but, in reality, the picture is recorded from the upper left corner as usual.
- The quality of images recorded in Multi Mode deteriorates slightly.
- Multi Mode cannot be used in still picture mode or when mega-pixel recording is set.

P-IN-P Mode (→ 27)

- Pictures in P-IN-P Mode cannot be recorded with Progressive PhotoShot.
- If the Palmcorder power is turned off, the smaller picture will disappear.
- A title cannot be inserted into the smaller picture.
- If the [CAMERA STILL] Button is pressed in P-IN-P Mode, the setting is cancelled.

Index Search Functions (→ 30)

- Index Search may not be possible at the beginning of tape.
- Because Photoshot Index Signals are not recorded on still pictures recorded in Continuous Photoshot Mode, the Photoshot Index Function cannot be used for these still pictures.
- Scene Index Search may not function properly if the interval between 2 scene index signals is shorter than 1 minute.

Playback Zoom Functions (→ 31)

- You cannot adjust volume in Playback Zoom Mode.
- If you turn off the Palmcorder or if you switch from VCR Mode to Camera Mode, Playback Zoom Mode is automatically cancelled.
- Even if Playback Zoom Functions are being used, images that are output from the DV Terminal or Digital Still Picture Terminal are not enlarged.
- As you enlarge an image, the quality of image suffers.
- You cannot use the Mirror Mode of Digital Effects and the Playback Zoom Functions simultaneously.
- If you select Multi-Picture Mode in the Playback Zoom Mode, equivalent magnification (1X) becomes zoom magnification.

Playback Digital Effect Functions (→ 31)

- Signals of images to which digital effects are added during playback cannot be output from the DV Terminal or Digital Still Picture Terminal.
- You cannot use the Wipe or Mix Function while playing back the non-recorded portion of tape.
- You cannot use the Mirror Mode of Digital Effects and the Playback Zoom Function simultaneously.

Multi Picture Mode (VCR Mode) (→ 32)

- The quality of Multi images deteriorates slightly.
- Playback multi-mode screens cannot be output through DV Terminal or Digital Still Picture Terminal.
- If there is input from DV Terminal, a multi screen cannot be created.
- When signals are input from Video Input/Output Jack or Audio-Video Input/Output Jack, a multi screen cannot be re-displayed.
- Signals input from Video Input/Output Jack or Audio-Video Input/Output Jack cannot be displayed on a multi screen.

■ Listening to Playback Sound Through Headphones (→ 28)

If you want to listen to the playback sound of a tape through headphones, set [AV JACK] on the [AV IN/OUT SETUP] Sub-Menu to [OUT/PHONES] and connect the headphones to the [PHONES] Jack on this Palmcorder. In this case, no sound (including a warning sound and shutter sound) will be reproduced through the built-in speaker of the Palmcorder. When the AV Cable is inserted into the AV Jack, the internal speaker works.

■ Selecting the Sound during Playback (→ 28, 33)

You can select the sound by using the [AUDIO OUT] on the [PLAYBACK FUNCTIONS] Sub-Menu.

STEREO: Stereo Sound (main sound and subsound)
L: Left channel sound (main sound)
R: Right channel sound (sub sound)

- If you dub a tape recorded at the [12bit] selected as the [AUDIO-REC] setting, playback sound becomes stereo sound regardless of whether [AUDIO] is set to [MIX] or to [AUDIO OUT].

■ Audio Dubbing (→ 33)

- The blank section of a tape cannot be dubbed.
- Sounds sent through the DV Terminal cannot be dubbed.
- If a tape has a non-recorded portion when the tape is dubbed, images and sounds may be disturbed when this portion of the tape is played back.
- If you set the tape counter back to 0 at the position where you want to stop Audio Dubbing so as to make it possible to use the Memory Stop function (→ 57), Audio Dubbing is terminated automatically when the tape reaches this position.
- In the case of importing data recorded with Audio Dubbing to a Computer using the Computer's software program, only the original sound (ST1) may be imported, depending on the software program.

Microphone Jack

When audio dubbing is carried out through an external microphone or audio equipment, connect it to the [MIC] Jack. In this case, the built-in microphone of the Palmcorder will be turned off.

■ Using with Digital Video Equipment (Dubbing) (→ 41)

- Regardless of the setting, dubbing is carried out automatically in the same audio recording Mode as that of the Cassette in the playback-side equipment.
- The images on the monitor of the recording side may be disturbed, but it does not affect the recorded images.
- Even if Playback Digital Effects, Playback Zoom, or Playback Title In have been used, these effects are not output from the DV Terminal.
- Even if you use device with DV Terminals (such as i.LINK), you may not be able to perform digital dubbing in some cases.

■ Card Functions (→ 34-39)

- Do not touch the connector terminal located on the back of the card.
- If the Card Slot Cover is open, the card cannot be accessed.
- Wide images cannot be recorded on the Memory Card.
- A card that was formatted with this Palmcorder may not be usable in other equipment. If this happens, please format the card with the equipment with which the card is to be used. Before proceeding with this operation, we suggest that you take the precautionary measure of storing important images in your personal computer.
- In the Card Photoshot mode, the Palmcorder automatically saves the file numbers (Imga0001.jpg, etc.) along with the pictures. A file number is recorded with each picture as a running number.

■ Recording to a Card from other equipment (→ 34, 40)

If you set the [TAPE/CARD] Selector to [CARD], you can use the Card Photoshot Function for externally input signals. (Not during recording.)

- Black streaks may appear at the four edges of the image.
- When the [PHOTO SHOT] Button is pressed, the image may seem to move backward momentarily, but this does not affect the recording.

■ Mega-pixel recording (→ 34)

- The Progressive Function is set to [ON].
- The shutter speed becomes 1/30-1/500.
- When viewed on a TV or liquid crystal monitor, image quality deteriorates slightly.
- The screen becomes wider slightly.
- Mega-pixel images cannot be recorded on a cassette as a Mega-pixel picture.

■ Card Playback (→ 35)

- In the case of displaying memory images on a Multi screen, if there are 7 or more images, they cannot be displayed all at once. Rotate the [PUSH] Dial or use the [-SEARCH] Button or [SEARCH+] Button to display the next 6 still pictures.
- When the pictures recorded by another Palmcorder are played back with this Palmcorder, the size of the pictures may be different from the recorded size.

■ Title Functions (→ 37)

- Regardless of the [PICTURE SIZE] setting, the size of created title picture is [640X480].
- If you create an original title, the number of pictures that can be recorded on the Memory Card decreases.
- If the number of pictures that can be recorded on the Memory Card is small, you may not be able to create an original title in some cases.
- When a title is displayed in VCR Mode, the title is not output from the DV Terminal or Digital Still Picture Terminal.
- When the [TAPE/CARD] Selector is set to [CARD] and [1200X900] is selected for [PICTURE SIZE], titles are not displayed.

■ DPOF setting (→ 39)

- The number of prints can be set from 0 to 99.
- Perform DPOF setting on the Palmcorder you are using.
- It may take some time to verify the DPOF setting. Please wait until the [ACCESS] Lamp goes off.

Caution for Use

■ After Use

- 1 Take out the Cassette. (→ 13)
- 2 Set the [OFF/ON/MODE] Switch to [OFF]. (→ 14)
- 3 Detach the Battery and retract the Viewfinder. (→ 12)
- 4 To protect the Lens, attach the supplied Lens Cap. (→ 13)

■ Tips for using your Palmcorder

When you use your Palmcorder in a rainy or snowy day or on a beach, make sure that no water enters the Palmcorder.

- Water may cause the Palmcorder or Cassette to malfunction. (Irreparable failure may occur.)
- If sea water splashes onto the Palmcorder, wet a soft cloth with tap water, wring it well, and use it to wipe the Palmcorder body carefully. Then, wipe it again thoroughly with a soft dry cloth.

Keep the Palmcorder away from magnetically charged equipment (such as a TV, game equipment, etc.)

- If you use the Palmcorder near a TV, images or sounds may be disturbed due to electromagnetic wave radiation.
- By strong magnetic fields created by speakers or large motors, recording on the tape may be damaged, or images may be distorted.
- Electromagnetic wave radiation generated by a microprocessor may adversely affect the Palmcorder, causing the disturbance of images and sounds.
- If the Palmcorder is affected by magnetically charged equipment and does not function properly, turn off the Palmcorder power and detach the Battery or AC Adaptor and then connect the Battery or AC Adaptor again. Thereafter, turn on the Palmcorder power.

Do not use your Palmcorder near radio transmitters or high-voltage lines.

- If you record pictures near radio transmitters or high-voltage lines, recorded images or sounds may be adversely affected.

Do not use this Palmcorder for surveillance purpose or other business use.

- If you use the Palmcorder for a long time, the internal temperature increases and, consequently, this may cause malfunction.
- This Palmcorder is not intended for industrial use.

When you use your Palmcorder on a beach or similar place, do not let sand or fine dust get into the Palmcorder.

- Sand or dust may damage the Palmcorder or Cassette. (Care should be taken when inserting and removing the Cassette.)

Do not spray insecticides or volatile chemicals onto the Palmcorder.

- If the Palmcorder is sprayed with such chemicals, the Palmcorder body may deform and the surface finish may peel off.
- Do not keep rubber or plastic product in contact with the Palmcorder for a long period of time.

For cleaning the Palmcorder, do not use any solvent, such as benzine, alcohol, thinner, etc.

- The Palmcorder body may deform and the surface finish may peel off.
- Before cleaning, detach the Battery or pull out the AC Cable from the AC Jack.
- Wipe the Palmcorder with a soft dry cloth. To remove stubborn stains, wipe with a cloth that is soaked in a detergent diluted with water and afterward finish wiping with a dry cloth.
- For storing or transporting the Palmcorder, place it in a bag or case lined with soft pads so as to prevent the coating on the Palmcorder body from being worn.

After use, be sure to take the Cassette out and detach the Battery from the Palmcorder or pull out the AC Cable from AC Jack.

- If the Cassette is left in the Palmcorder, the tape sags and deteriorates.
- If you leave the Battery attached to the Palmcorder for a long time, the voltage drops excessively, and the Battery will not function even after it is recharged.

■ About AC Adaptor

- If the temperature of the Battery is extremely high or extremely low, the [CHARGE] Lamp may continue flashing, and the Battery may not charge. After the temperature of the Battery has decreased or increased sufficiently, charging starts automatically. If the [CHARGE] Lamp continues to flash even after the Battery temperature has decreased or increased sufficiently, the Battery or AC Adaptor may be faulty. In this case, please contact your dealer.
- If the Battery is warm, charging takes a longer time than normal.
- If you use the AC Adaptor near a radio, radio reception may be disturbed. Keep the AC Adaptor 1 meter or more away from radio.
- When the AC Adaptor is in use, it may generate whirring sounds. However, this is normal.
- After use, be sure to pull out the AC Cable from the AC Jack. (If they are left connected, a minute amount of current is consumed.)
- Keep the electrodes of the AC Adaptor and Battery always clean.

■ Condensation

If excessive moisture condenses in the unit, [DEW DETECTED] Indication will flash, and the Palmcorder will automatically turn off after about 1 minute.

In this case, follow the steps below:

1 Take out the Cassette.

- None of the other functions operate. Depending on the amount of condensation, removing the Cassette may even become difficult. If this happens, wait for 2 to 3 hours before taking the Cassette out.

2 Open the Cassette Compartment and wait for 2 to 3 hours.

- The number of hours to wait depends on the amount of condensation and ambient temperature.

3 2 to 3 hours later, turn on the Palmcorder and check to see if the [DEW DETECTED] Indication is displayed.

- Even if the [DEW DETECTED] Indication is not displayed, as a precaution, please wait for another hour before using the Palmcorder.

Watch for Condensation Even Before the [DEW DETECTED] Indication Is Displayed.

- Because condensation takes place gradually, the [DEW DETECTED] Indication may not be displayed during the first 10 to 15 minutes of condensation formation inside the Palmcorder.

- In extremely cold places, condensation may freeze and form frost. In this case, the frost melts first, thus forming condensation, and then it takes another 2 to 3 hours to eliminate the condensation.

When the Lens Is Fogged:

Set the [OFF/ON/MODE] Switch to [OFF] and leave the Palmcorder in this condition for about 1 hour. When the lens temperature becomes close to the ambient temperature, the fog disappears naturally.

■ Digital Video Head Cleaner

If the heads (the parts that make contact with tape) are dirty, mosaic-like noise patterns may appear on the playback image, or the screen as a whole becomes black. If the heads are extremely dirty, recording performance deteriorates, and, in the worst case, the Palmcorder cannot record at all.

Causes of Digital Video Heads

- Large quantity of dust in the air
- High-temperature and high-humidity environment
- Damaged tape
- Long operating hours

Using Mini-DV Format Digital Video Head Cleaner

- 1 Insert the Head Cleaner into the Palmcorder in the same manner as a Video Cassette.
- 2 Press the [▶] Button, and 20 seconds later, press the [■] Button. (Do not rewind the tape.)
- 3 Take out the head cleaner. Insert a Video Cassette and start recording. Then, play the tape back to check the recorded image.
- 4 If the image is not still clear, repeat Steps 1 to 3. (Do not use the Head Cleaner for 3 times or more consecutively.)

Notes:

- Do not rewind every time you use the Head Cleaner. Rewind only when the tape reaches the end, and then use it again from the beginning in the same manner as before.
- If the heads become dirty soon after cleaning, the tape may be damaged. In this case, immediately stop using that Cassette.
- Do not clean the heads excessively. (Excessive cleaning may cause excessive wear of the heads. If the heads are worn, images cannot be played back even after the heads are cleaned.)
- If the dirty heads cannot be cleaned with the head cleaner, the Palmcorder needs to be cleaned at a service center. Please consult a distributor.
- Video head cleaners can be purchased from service centers.
- Head cleaning due to dirty heads is not considered a malfunction of the product. It is not covered by the warranty.

Periodical Check-up

To maintain the highest image quality, we recommend replacement of worn parts, such as heads, etc., after approximately 1000 hours of use. (This, however, depends on operating conditions, such as temperature, humidity, dust, etc.)

■ Optimal Use of the Battery

Battery Characteristics

This Battery is a chargeable lithium ion battery. Its ability to generate power is based upon the chemical reaction that takes place inside it. This reaction is susceptible to the surrounding temperature and humidity, and, if the temperature is too high or too low, the operating time of the Battery becomes shorter. If the Battery is used in an extremely cold environment, the Battery may operate only for about 5 minutes. If the Battery becomes extremely hot, a protective function may operate, and the Battery may become unusable for a while.

Be Sure to Detach the Battery After Use

Be sure to detach the Battery from the Palmcorder. (If it is left attached to the Palmcorder, a minute amount of current is consumed even when the Palmcorder power is off.) If the Battery is left attached to the Palmcorder for a long time, over discharge takes place. The Battery may become unusable after it is charged.

Disposing of an unusable Battery

- The Battery has a limited life.
- Do not throw the Battery into fire because it may cause an explosion.

Always Keep the Terminals of the Battery Clean

Prevent the terminals from getting clogged with dirt, dust, or other substances.

If you drop the Battery accidentally, check to see if the Battery body and terminals are deformed.

Attaching a deformed Battery to the Palmcorder or AC Adaptor may damage the Palmcorder or AC Adaptor.

■ Cautions for Storage

Before storing the Palmcorder, take the Cassette out and detach the Battery.

Store all the components in a dry place with a relatively stable temperature.

- Recommended Temperature: 59°F to 77°F (15°C to 25°C), Recommended Humidity: 40% to 60%

Palmcorder

- Wrap it with a soft cloth to prevent dust from getting into the Palmcorder.
- Do not leave the Palmcorder in places that expose it to high temperature.

Battery

- Extremely high temperatures or low temperatures will shorten the life of the Battery.
- If the Battery is kept in smoky or dusty places, the terminal may rust and cause malfunctions.
- Do not allow the Battery terminals to come in contact with metal objects (such as necklaces, hairpins, etc.) This can result in a short circuit or heat generation and, if you touch the Battery in this condition, you may be badly burned.
- Store the Battery in a completely discharged state. To store the Battery for a long period of time, we recommend you charge it once every year and store it again after you completely use up the charged capacity.

Cassette

- Before storing it, rewind the tape to the beginning. If the Cassette is left for more than 6 months with the tape stopped midway, the tape sags (although it depends on the storage condition.) Be sure to rewind to the beginning.
- Store the Cassette in its case. Dust, direct sunlight (ultraviolet rays), or humidity may damage the tape. Dust contains hard mineral particles, and dusty Cassettes damage the heads of the Palmcorder and other components. Develop a habit of returning the Cassette back to its case.
- Once every half year, wind the tape to the end and then rewind it to the beginning. If the Cassette is left for 1 year or longer without winding or rewinding, temperature and humidity changes may cause the Cassette to deform due to swelling, shrinking, and so forth. The wound tape may stick to itself.
- Do not place a Cassette near highly magnetic substances or equipment.
- The surface of tape is covered with extremely minute magnetic particles, upon which signals are recorded. Magnetic necklaces, toys, etc., have magnetic force that is stronger than you may normally expect, and they may erase the contents of a recording or may cause noise in images and sounds.

■ LCD Monitor/Viewfinder/Lens Hood

LCD Monitor

- In a place with drastic temperature changes, condensation may take place on the LCD Monitor. Wipe it with soft dry cloth.
- If your Palmcorder is extremely cold when you turn its power on, the image on the LCD Monitor is slightly darker than usual at first. However, as the internal temperature increases, it goes back to the normal brightness.

.....

Extremely high precision technology is employed to produce the LCD Monitor screen featuring a total of approximately 200,000 pixels. The result is more than 99.99% effective pixels with a mere 0.01% of the pixels inactive or always lit. However, this is not a malfunction and does not affect the recorded picture.

.....

Viewfinder

- Do not direct the Viewfinder or Lens to the sun. Internal components may be seriously damaged.
- When the Palmcorder is used with a large capacity Battery attached to it, it is not practical to look in the Viewfinder from behind the Battery. In this case, lift up the Viewfinder to an easy-to-see angle.

.....

Extremely high precision technology is employed to produce the Viewfinder screen featuring a total of approximately 113,000 pixels. The result is more than 99.99% active pixels with a mere 0.01% of the pixels inactive or always lit. However, this is not a malfunction and does not affect the recorded picture.

.....

Lens Hood

- Do not attach other conversion lenses in front of the Lens Hood; there is no mount to be used for the attachment.
- When you wish to attach the Tele Conversion Lens (not supplied), Wide Conversion Lens (not supplied), MC Protector (not supplied), or ND Filter (not supplied), first of all, turn the Lens Hood counterclockwise. If the filter is used, the Lens Hood can be mounted on the filter.
- If you push the [W/T] Lever toward [W] during recording with the filter or conversion lens attached to the Palmcorder, 4 corners of the image may become dark (vignetting). For details, please refer to the operating instructions for your accessories

Explanation of Terms

■ Digital Video System

In a digital video system, images and sounds are converted into digital signals and recorded on a tape. This complete digital recording is capable of recording and playback with minimal image and sound deterioration.

In addition, it automatically records data, such as Time Code and date/time, as digital signals.

Compatibility with S-VHS or VHS Cassettes

Because this Palmcorder employs a digital system for recording image and sound data, it is not compatible with conventional S-VHS or VHS video equipment that employs an analog recording system.

The size and shape of the Cassette are also different.

Compatibility with Output Signals

Because AV signal output from the AV signal output jack is analog (the same as conventional video systems), this Palmcorder can be connected with S-VHS or VHS video or a TV for playback.

■ Focus

Auto Focus Adjustment

The Auto Focus System automatically moves the internal focusing lens forward or backward and adjusts the focus so that the subject can be seen clearly.

However, the Auto Focus System does not function properly for the following subjects or under the following recording conditions.

Please use the Manual Focus Mode instead.

- 1) **Recording a subject whose one end is located closer to the Palmcorder and the other end farther away from it**
 - Because Auto Focus makes adjustments at the center of an image, it may be impossible to focus on a subject that is located in both foreground and background.
- 2) **Recording a subject behind dirty or dusty glass**
 - Because the focus is on the dirty glass, the subject behind the glass will not be focused.
- 3) **Recording a subject in dark surroundings**
 - Because the light information that comes through the lens decreases considerably, the Palmcorder cannot focus correctly.
- 4) **Recording a subject that is surrounded by objects with glossy surfaces or by highly reflective objects**
 - Because the Palmcorder focuses on the objects with glossy surfaces or on highly reflective objects, the recording subject may become blurry.
- 5) **Recording a fast-moving subject**
 - Because the focus lens inside moves mechanically, it cannot keep up with the fast-moving subject.
- 6) **Recording a subject with little contrast**
 - Because the Palmcorder achieves focus based upon the vertical lines of an image, a subject with little contrast, such as a white wall, may become blurry.

■ White Balance Adjustment

Depending on the type of light source, the colors recorded by the Palmcorder may be affected. In some cases, images may be recorded with bluish or reddish hue. To minimize the effect of light on the subject's color, what is called White Balance Adjustment becomes necessary.

White Balance Adjustment

White Balance Adjustment recognizes the color of light and makes adjustment so that the white color will become pure white.

Auto White Balance Adjustment

This Palmcorder stores settings that are optimal for several kinds of general light sources. The Palmcorder determines the hue of light that it receives through the lens and White Balance Sensor, thereby judging the recording condition, and selects the closest hue setting. This function is called Auto White Balance Adjustment.

However, since white balance settings for only several kinds of light sources are stored, the Auto White Balance Function does not operate properly when recording occurs under light that is out of the range of the setting values.

■ Time Code

Time Code signals are data that indicate time measured in hours, minutes, seconds, and frames (30 frames per second.) If this data is included in a recording, an address is assigned to each image on the tape.

- The Time Code is automatically recorded as a part of the sub-code at each recording.
- When a new (previously unrecorded) Cassette is inserted, the Time Code automatically starts from zero. If a recorded Cassette is inserted, the Time Code picks up from the point where the last scene was recorded. (In this case, when the Cassette is inserted, the zero display [0h00m00s00f] may appear, but the Time Code starts from the previous value.)
- The Time Code cannot be reset to zero.
- Unless the Time Code is continuously recorded from the beginning of a tape, accurate editing may not be possible. To ensure that the Time Code will be recorded with no breaks, we recommend the use of the Camera Search Function (→ 20) or the Blank Search Function (→ 29) before recording a new scene.

■ Memory Stop Function

The Memory Stop Function is useful for the following operations.

Rewinding or fast-forwarding a tape to a desired position

- 1 **Set [C.DISPLAY] on the [DISPLAY SETUP] Sub-Menu to [MEMORY].**
- 2 **Reset the Tape Counter to zero at the tape position from which you want to play it back later. (→ 10, 16)**
- 3 **Start playback or recording.**
- 4 **When playback or recording is over: slide the [OFF/ON/MODE] Switch from on to put the Palmcorder in the VCR Mode.**
 - The [VCR] Lamp lights up.
- 5 **Rewind the tape.**
 - The tape automatically stops approximately at the position where the counter was set to zero.

Stopping editing automatically during audio dubbing

- 1 **Set [C.DISPLAY] on the [DISPLAY SETUP] Sub-Menu to [MEMORY].**
- 2 **Reset the Tape Counter to zero at the position where you want to stop editing.**
- 3 **Play back the still pictures where you want to start audio dubbing.**
- 4 **Start audio dubbing. (→ 33)**
 - Audio dubbing automatically stops at the position where the counter was set to zero.

Specifications

Digital Palmcorder Information for your safety

Power Source:	DC 7.8/7.2 V
Power Consumption:	Recording 6.5 W
Recording Format:	Mini DV (Consumer-use Digital Video SD Format)
Tape Used:	6.35 mm digital video tape
Recording/Playback Time:	SP: 80 min.; LP: 120 min. (with DVM80)
Video	
Recording System:	Digital Component
Television System:	EIA Standard: 525 lines 60 Fields NTSC color signal
Audio	
Recording System:	PCM Digital Recording 16 bit (48 kHz/2 track), 12 bit (32 kHz/4 track)
Image Sensor:	1/4-inch CCD Image Sensor
Lens:	Auto Iris, F1.8, Focal Length; 3.55-35.5 mm, Macro (Full Range AF) 37 mm
Filter Diameter:	37 mm
Zoom:	10:1 Power Zoom
Monitor:	2.5-inch LCD (PV-DV851) 3.0-inch LCD (PV-DV901)
Finder:	Color Electronic Viewfinder
Microphone:	Stereo
Speaker:	1 round speaker 20 mm
Standard Illumination:	1,400 lx
Minimum Required Illumination:	12 lx
Video Output Level:	1.0 Vp-p, 75 ohm
S-Video Output Level:	Y Output: 1.0 Vp-p, 75 ohm C Output: 0.286 Vp-p, 75 ohm
Audio Output Level:	316 mV, 600 ohm
Video Input Level:	1.0 Vp-p, 75 ohm
S-Video Input Level:	Y Input: 1.0 Vp-p, 75 ohm C Input: 0.286 Vp-p, 75 ohm
Audio Input Level (Line):	316 mV, 10 kohm or more
Mic Input:	Mic sensitivity -50 dB (0 dB = 1 V/Pa, 1 kHz) (Stereo mini jack)
Digital Still Picture:	Digital Still Picture Output, Control Signal Input/Output (Transfer rate: max. 115 kbps)
Digital Interface:	DV Output Terminal (i.LINK, 4-pin)
Dimensions:	2-5/8(W) × 3-3/8 (H) × 6-5/8 (D) inch 68 (W) × 86 (H) × 170 (D) mm (PV-DV901)
Weight:	1.21lbs. (0.55 kg) (without Battery and DV cassette) (PV-DV851) 1.19lbs. (0.54 kg) (without Battery and DV cassette)
Operating Temperature:	32 °F -104 °F (0 °C -40 °C)
Operating Humidity:	10%-80%

Card Memory Functions	
Recording Media:	SD Memory Card, MultiMediaCard
Image Compression:	JPEG

Maximum Number of pictures that can be recorded on the supplied SD Memory Card (PV-DV901)

When the size of pictures is [1200×900]	
FINE:	approx. 25 pictures
NORMAL:	approx. 40 pictures
ECONOMY:	approx. 60 pictures

When the size of pictures is [640×480]	
FINE:	approx. 100 pictures
NORMAL:	approx. 200 pictures
ECONOMY:	approx. 400 pictures

Maximum Number of pictures that can be recorded on the supplied SD Memory Card (PV-DV851)

When the size of pictures is [1200×900]	
FINE:	approx. 9 pictures
NORMAL:	approx. 18 pictures
ECONOMY:	approx. 27 pictures

When the size of pictures is [640×480]	
FINE:	approx. 45 pictures
NORMAL:	approx. 95 pictures
ECONOMY:	approx. 190 pictures

- When you record in one Memory Card using various modes (FINE, NORMAL, ECONOMY), the maximum number of images available will not exceed the indications stated above.
- The indicated Maximum Number of pictures that can be recorded is an approximate calculation. The number of recordable still pictures on the SD Memory Card may differ depending on the subject.

AC Adaptor Information for your safety

Power Source:	AC 110-240 V, 50/60 Hz
Power Consumption:	18W
DC Output:	DC 7.8 V, 1.4 A (Palmcorder Operation) DC 8.4 V, 1.2 A (Battery Charging)

Dimensions:	2-3/4 (W) × 1-3/4 (H) × 4-9/16 (D) inch 70 (W) × 45 (H) × 116 (D) mm
Weight:	0.363lbs. (0.165 kg)











USB Reader/Writer for SD Memory Card

Power Source:	DC 5 V
---------------	--------

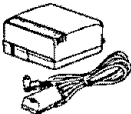
Compatible media:	SD Memory Card, MultiMediaCard
Interface:	USB standard Rev1.1
Operating Temperature:	32 °F - 104 °F (0 °C - 40 °C)
Dimensions:	3.6 (W) × 2.2 (H) × 0.6 (D) inch 92 (W) × 56 (H) × 15 (D) mm
Cable length:	39.4 inch (1 m)
Weight:	0.19 lbs. (85 g)

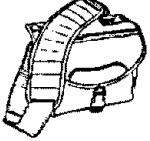
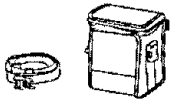
Weight and dimensions shown are approximate.
Designs and specifications are subject to change without prior notice.

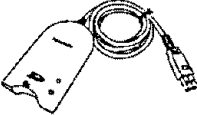
Palmcorder Accessory System

Accessory#	Figure	Description	Price
PV-DAC11A		AC Adaptor with AC Cable and DC Cable	\$120.00
*CGR-D08A/1B (Replaces *CGR-D120A/1B)		800mAh/ Rechargeable Lithium Ion Battery Pack	\$69.95
*CGR-D16A/1B (Replaces *CGR-D220A/1B)		1600mAh/ Rechargeable Lithium Ion Battery Pack	\$99.95
*CGP-D28A/1B		2800mAh/Rechargeable Lithium Ion Battery Pack	\$129.95
*CGR-D53A/1K (Replaces *CGR-D815A/1B)		5300mAh/Rechargeable Lithium Ion Battery Pack	\$229.95
PV-DDC9		DV Interface Cable (i.LINK) (4-pin to 4-pin)	\$55.00
PV-DRC9		IR Remote Control	\$29.95
PV-H150		Carrying Case	\$49.95
PV-H210		Leather Carrying Case	\$99.95
RP-SD064 RP-SD032 RP-SD016		64 MB SD Memory Card 32 MB SD Memory Card 16 MB SD Memory Card	\$179.95 \$119.95 \$79.95
BN-SDCAPU/1B		USB Reader/Writer for SD Memory Card (compatible with MultiMediaCard)	\$79.95
BN-SDABPU/1B		SD PCMCIA Adaptor (compatible with MultiMediaCard)	\$79.95
PV-PD2100		Digital Video Printer	\$599.95

*Please refer to page 12, concerning the battery charging time and available recording time.

Palmcorder Accessory order Form

Please photocopy this form when placing an order.

1. Palmcorder Model # _____

2. Items Ordered

Accessory #	Description	Price Each	Quantity	Total Price
Subtotal				
Your State & Local Sales Tax				
Shipping & Handling				6.95
Total Enclosed				

3. Method of payment (check one)

- Check of Money Order enclosed (NO C.O.D.SHIPMENTS)
- VISA Credit Card # _____
- MasterCard Expiration Date _____
- Discover Customer Signature _____

Make Check or Money Order to: PANASONIC ACCESSORIES

(Please do not send cash)

4. Shipping information (UPS delivery requires complete street address)

Ship To:

Mr.

Mrs.

Ms.

First

Last

Phone#:

Day () _____

Street Address

Night () _____

City

State

Zip

TO OBTAIN ANY OF OUR PALMCORDER ACCESSORIES YOU CAN DO ANY OF
THE FOLLOWING:
VISIT YOUR LOCAL PANASONIC DEALER
OR
CALL PANASONIC'S ACCESSORY ORDER LINE AT 1-800-332-5368
[6 AM-5 PM M-F, 6 AM-10:30 AM SAT, PACIFIC TIME]
OR
MAIL THIS ORDER TO: PANASONIC SERVICES COMPANY ACCESSORY ORDER OFFICE
20421 84th Avenue South Kent, WA. 98032

Before Requesting Service

(Problems and Solutions)

If you have a problem with your Digital Palmcorder, it may be something you can correct yourself. Check the list below for symptoms and corrections.

Problems	Solutions
The Palmcorder power cannot be turned on.	Is the power source connected correctly?
The Palmcorder power is turned off automatically.	If you leave the Palmcorder in Recording Pause Mode for more than 5 minutes, the power is turned off automatically to protect the tape and to save the Battery power.
The Palmcorder power does not stay on long enough.	Is the Battery low? Charge the Battery or attach a fully charged Battery.
Something is wrong with the Palmcorder's operation. Alternatively, the Palmcorder is turned on but no functions operate.	Press the [RESET] Button on the Palmcorder with a pointed object. If this does not solve the problem, first disconnect the power supply and wait for a minute or so, and then reconnect the power supply to turn the power back on. (If the above operation is performed when the [ACCESS] Lamp of the Card Slot is lighting, the data of the Card may be damaged.)
Battery runs down quickly.	<ul style="list-style-type: none"> • Is the Battery fully charged? Charge it with the AC Adaptor. • Are you using the Battery in an extremely cold place? In cold places, the operating time of the Battery becomes shorter. • Has the Battery worn out? If the operating time is still too short even after the Battery is fully charged, the Battery has worn out.
The Battery cannot be charged.	If the DC Cable is connected to the AC Adaptor, charging cannot be performed. Disconnect the DC Cable.
Recording does not start although power is supplied to the Palmcorder and the Cassette is correctly inserted.	<ul style="list-style-type: none"> • Is the accidental erasure protection tab on the Cassette open? If it is open (set to [SAVE]), recording cannot be performed. • Is the tape wound to the end? Insert a new Cassette. • Is the Palmcorder power turned on? • Is the [CAMERA] Lamp on? If the [CAMERA] Lamp is not on, no recording function can be operated. • Has condensation occurred? Wait until the [DEW DETECTED] Indication disappears.
Audio dubbing cannot be performed.	<ul style="list-style-type: none"> • Is the accidental erasure prevention slider on the Cassette open? If it is open (set to [SAVE]), recording cannot be performed. • Are you attempting to edit a tape portion that was recorded in LP Mode? LP Mode does not allow audio dubbing to operate.
The Time Code becomes inaccurate.	The Time Code Indication counter may not be constant in the reverse direction in Slow Motion Playback Mode, but this is not a malfunction.
The Remaining Tape Time Indication disappears.	When you record still pictures in Photoshot Mode, the Remaining Tape Time Indication may disappear temporarily. However, it reappears when the Palmcorder is set back to Normal Recording Mode.
The Remaining Tape Time Indication does not match the actual remaining tape time.	<ul style="list-style-type: none"> • If scenes of less than 15 seconds are continuously recorded, the remaining tape time cannot be displayed correctly. • In some cases, the Remaining Tape Time Indication may show remaining tape time that is 2 to 3 minutes shorter than the actual remaining tape time.

If you have a problem with your Digital Palmcorder, it may be something you can correct yourself. Check the list below for symptoms and corrections.

Problems	Solutions
Images cannot be played back even when the [▶] Button is pressed.	Is the [VCR] Lamp on? If the [VCR] Lamp is not on, the playback function cannot be used.
Mosaic-like noise patterns appears on images during Cue, Review or Slow Motion Playback.	This phenomenon is characteristic of digital video systems. It is not a malfunction.
Although the Palmcorder is correctly connected to a TV, playback images cannot be seen.	Have you selected Video Input on the TV? Please read the operating instructions of your TV and select the channel that matches the input jacks used for the connection.
Playback image is not clear.	Are the heads of the Palmcorder dirty? If the heads are dirty, playback image cannot be clear.
No sound is played back from the built-in speaker or headphones of the Palmcorder.	Is the volume too low? During playback, continue pressing the [PUSH] Dial until the [VOLUME] Indication appears. Then, rotate the [PUSH] Dial to adjust the volume.
Different sounds are reproduced at the same time.	[AUDIO] on the [PLAYBACK FUNCTIONS] Sub-Menu of the [VCR FUNCTIONS] Main-Menu has been set to [MIX]. As a result, the original sound and sound that was recorded by audio dubbing are played back together. It is possible to reproduce the sounds separately.
The original sound was erased when audio dubbing was performed.	If you perform audio dubbing on a recording done in [16bit] Mode, the original sound will be erased. If you want to preserve the original sound, be sure to select [12bit] Mode at the time of recording.
Sounds cannot be played back.	<ul style="list-style-type: none"> • Although a Cassette with no audio dubbing is being played, is [AUDIO] on the [PLAYBACK FUNCTIONS] Sub-Menu of the [VCR FUNCTIONS] Main-Menu set to [ST2]? To play back a Cassette with no audio dubbing, [AUDIO] must be set to [ST1]. • Is the Variable Speed Search Function working? Press the [▶] Button to cancel the Variable Speed Search Function.
The recorded picture on the Memory Card is not clear.	Do you have [REC MODE] on the [CARD SETUP] Sub-Menu set to [ECONOMY]? If recording is done with it set to [ECONOMY], a detailed image may show a mosaic pattern. Set the [REC MODE] to [NORMAL] or [FINE]. (→ 34)
Card Photoshot playback pictures do not look normal.	There is a possibility that the images are damaged. To prevent the loss of image data, we recommend that you back images up on a Cassette or personal computer. (→ 36, 45, 46)
Even if a Card is formatted, it cannot be used.	There is a possibility of damage to either the Palmcorder or the Card. Please contact Panasonic Call Center.

Request for Service Notice

If any of the following numbers appear on-screen, please check the list below before requesting service. You can correct yourself. But if it doesn't solve the problem, consult service center.

Error No.	Description	Countermeasure
U10	Condensation	Wait until the [DEW DETECTED] indication disappear. (→ 55)
U11	Dirty Head	Clean the Video Head. (→ 55)
F01, F02 F03, F04 F05	Malfunction	Press the [RESET] Button (→ 61), and after 3 or 4 seconds, insert the Cassette and/or Eject the Cassette (→ 13). If this does not solve the problem, please consult service center
F31, F51 F52	Malfunction	Press the [RESET] Button (→ 61). If this does not solve the problem, please consult service center.

Please photocopy this form when making a request for service notice.

In the unlikely event this product needs service.

Request for Service Notice:

- Please include your **proof of purchase**.
(Failure to do so will delay your repair.)
- To further speed your repair, please provide an explanation of what wrong with the unit and any symptom it is exhibiting.

Mail this completed form and your Proof of Purchase along with your unit to:
Panasonic Services Company
1705 N. Randall Road
Elgin, IL. 60123-7847
Attn: Camcorder Repair

Please write the displayed above Self Diagnostic number here.

Limited Warranty

Panasonic Consumer Electronics Company, Division of
Matsushita Electric Corporation of America, One Panasonic
Way Secaucus, New Jersey 07094

Panasonic Sales Company,
Division of Matsushita Electric of Puerto Rico, Inc.
AVE. 65 de Infantería, Km. 9.5 San Gabriel

PANASONIC Video Products Limited Warranty

Panasonic Consumer Electronics Company or Panasonic Sales Company (collectively referred to as "the Warrantor") will repair this product with new or refurbished parts, free of charge, in the USA or Puerto Rico, in the event of a defect in materials or workmanship as follows (all time periods commence from the date of the original purchase):

PRODUCT	PARTS	LABOR	SERVICE	CONTACT NUMBER
CAMCORDER	ONE (1) YEAR, EXCEPT CCD IMAGE SENSOR CCD IMAGE SENSOR SIX (6) MONTHS	NINETY (90) DAYS NINETY (90) DAYS	Carry In or Mail In	1 800 211 PANA(7262)
VCR	ONE (1) YEAR	NINETY (90) DAYS	Carry In or Mail In	1 800 211 PANA(7262)
A/V MIXER	ONE (1) YEAR	NINETY (90) DAYS	Carry In or Mail In	1 800 211 PANA(7262)
MONITOR VCR Combination	ONE (1) YEAR, EXCEPT CRT CRT TWO (2) YEARS	NINETY (90) DAYS CRT NINETY (90) DAYS	Carry In: 21" CRT and Smaller In home or carry in: 22" CRT and Larger	1 800 211 PANA(7262)

Batteries (if included) - New rechargeable batteries in exchange for defective rechargeable batteries for ten (10) days. Non-rechargeable batteries are not warranted.

Tape (if included) - New video cassette tape in exchange for a defective video cassette tape for five (5) days.

In-home, carry-in or mail-in service, as applicable, in the USA can be obtained during the warranty period by contacting a Panasonic Services Company (PASC) Factory Servicenter listed in the Service Directory. Or call toll free contact number listed above, to locate an authorized PASC Servicenter. Carry-in or mail-in service in Puerto Rico can be obtained during the warranty period by calling the Panasonic Sales Company telephone number listed in the Servicenter Directory.

This warranty is extended only to the original purchaser. A purchase receipt or other proof of the date of the original purchase is required before warranty service is rendered.

This warranty only covers failures due to defects in materials and workmanship which occur during normal use and does not cover normal maintenance, including, but not limited to, video and audio head cleaning.

The warranty does not cover damage which occurs in shipment, or failures which are caused by products not supplied by the warrantor, or failures which result from accident, misuse, abuse, neglect, mishandling, misapplication, alteration, modification, faulty installation, set-up adjustments, improper antenna, inadequate signal pickup, maladjustment of consumer controls, improper operation, power line surge, improper voltage supply, lightning damage, commercial use such as hotel, office, restaurant, or other business or rental use of the product, or service by anyone other than a PASC Factory Servicenter or a PASC authorized Servicenter, or damage that is attributable to acts of God.

LIMITS AND EXCLUSIONS

There are no express warranties except as listed above.

THE WARRANTOR SHALL NOT BE LIABLE FOR INCIDENTAL OR CONSEQUENTIAL DAMAGES (INCLUDING, WITHOUT LIMITATION, DAMAGE TO RECORDING MEDIA) RESULTING FROM THE USE OF THIS PRODUCTS, OR ARISING OUT OF ANY BREACH OF THE WARRANTY. ALL EXPRESS AND IMPLIED WARRANTIES, INCLUDING THE WARRANTIES OF MERCHANTABILITY AND FITNESS FOR PARTICULAR PURPOSE, ARE LIMITED TO THE APPLICABLE WARRANTY PERIOD SET FORTH ABOVE. Some states do not allow the exclusion or limitation of incidental or consequential damages, or limitations on how long an implied warranty lasts, so the above exclusions or limitations may not apply to you.

This warranty gives you specific legal rights and you may also have other rights which vary from state to state.

If a problem with this product develops during or after the warranty period, you may contact your dealer or Servicenter. If the problem is not handled to your satisfaction, then write to the Consumer Affairs Department at the Panasonic Consumer Electronics Company address above.

SERVICE CALLS WHICH DO NOT INVOLVE DEFECTIVE MATERIALS OR WORKMANSHIP AS DETERMINED BY THE WARRANTOR, IN ITS SOLE DISCRETION, ARE NOT COVERED. COSTS OF SUCH SERVICE CALLS ARE THE RESPONSIBILITY OF THE PURCHASER.

warvid 8/8/2000

Servicenter List

For Product Information, Operating Assistance, Literature Request, Dealer Locations, and all Customer Service inquiries please contact:

1-800-211-PANA(7262), Monday-Friday 9am-9pm Saturday-Sunday 9am-7am, EST.
or send e-mail consumerproducts@panasonic.com

Web Site: <http://www.panasonic.com>

You can purchase parts, accessories or locate your nearest servicenter by visiting our Web Site.

Accessory Purchases:

1-800-332-5368 (Customer Orders Only)

Panasonic Services Company 20421 84th Avenue South, Kent, WA 98032

(6 am to 5 pm Monday - Friday; 6 am to 10:30 am Saturday; PST)

Product Repairs

Centralized Factory Servicenter

Panasonic Services Company

MAIL TO : 1705 N. Randall Road,
Elgin, IL 60123-7847
Attention: Digital Camera Repair

Please carefully pack and ship, prepaid and insured, to the Elgin centralized repair Factory Servicenter. While there will be added handling delays, you may bring your unit to one of the following locations who will then forward the unit to Elgin for repair.

Customer's in Puerto Rico, please ship or carry in to location below ("Service in Puerto Rico").

(Visa, Master Card, Discover Card, American Express, Check)

Factory Service Center Locations

CALIFORNIA

6550 Katella Avenue
Cypress, CA 90630 800
Dubuque Avenue
S. San Francisco,
CA 94080
3878 Ruffin Road
Suite A
San Diego, CA 92123

COLORADO

1640 South Abilene
Street Suite D
Aurora, CO 80012

FLORIDA

3700 North 29th Avenue
Suite 102
Hollywood, FL 33020

GEORGIA

8655 Roswell Road
Suite 100
Atlanta, GA 30350

ILLINOIS

9060 Golf Road
Niles, IL 60714
1703 North Randall Road
Elgin, IL 60123
(Pick-up/ Drop-off only)

MARYLAND

62 Mountain Road
Glen Burnie MD 21061

MASSACHUSETTS

60 Glacier Drive,
Suite G
Westwood, MA 02090

MINNESOTA

7850-12th Avenue South
Business Center
Bloomington, MN 55425

OHIO

2236 Waycross
Road Civic Center Plaza
Forest Park, OH 45240

PENNSYLVANIA

2221 Cabot Blvd. West
Suite B
Langhorne, PA 19047

TEXAS

13615 Welch Road
Suite 101
Farmers Branch,
TX 75244

WASHINGTON

20425-84th Avenue
South
Kent, WA 98032

HAWAII

99-859 Iwaiwa Street
Aiea, Hawaii 96701
Phone (808) 488-1996
Fax (808)486-4369

Service in Puerto Rico

Matsushita Electric of Puerto Rico, Inc. Panasonic Sales Company/Factory Servicenter:
Ave. 65 deInfernteria. Km. 9.5 San Gabriel Industrial Park Carolina, Puerto Rico00985
Phone(787)750-4300 Fax (787)768-2910

As of January 2001

Software License Agreement

Portions of the software on this CD-ROM are Copyright © 2000 Phoenix Technologies Ltd. and its suppliers. All rights reserved.

BY INSERTING THIS CD-ROM INTO YOUR CD-ROM DRIVE YOU INDICATE YOUR ACCEPTANCE TO ALL TERMS OF THIS SHRINK WRAP LICENSE AGREEMENT. YOU ARE ONLY GRANTED A LICENSE TO USE THE SOFTWARE PROVIDED UNDER THIS AGREEMENT ON THE CONDITION THAT YOU AGREE TO THE TERMS OF THIS AGREEMENT. IF YOU DO NOT AGREE TO THE TERMS OF THIS AGREEMENT, RETURN THE CD-ROM TO MATSUSHITA ELECTRIC INDUSTRIAL CO., LTD. ("MATSUSHITA") OR ITS DISTRIBUTOR.

- 1) **Matsushita will allow the customer to use the software (CD-ROM/Operating Instructions), however, no copyright or other intellectual property rights will be transferred to the customer.**
- 2) **Regardless of whether this software is paid for or not, the user of this software may not transfer it to a third party.**
- 3) **A copy of the software may be made only for backup purposes.**
- 4) **This software may only be used in one computer and may not be used in multiple computers.**
- 5) **Reverse engineering, modifying or creating modified versions of the software is prohibited. Matsushita and distributors and their suppliers will not be liable for any damages due to the use of any modified versions software.**
- 6) **If there are any problems with software please call or write the Matsushita contact. Regarding any inquiries about problems with the software, Matsushita will provide information about bugs, or information about how to use the software that are known to Matsushita. The specification of the software are subject to change without notice.**
- 7) **#6 above is the only remedy that Matsushita will provide for [problems with] the software. Matsushita and its distributors and their suppliers will not take responsibility for any claims made by third parties for any damages caused by the use of the software.**
- 8) **If the customer takes the software out of the country in which it was purchased, the customer must follow the export regulations of Japan and those of the United States and/or other countries.**

Index

A

AC Adaptor.....	12
ArcSoft.....	42, 44
Audio Dubbing.....	33
Auto Focus.....	57
Auto White Balance Adjustment.....	57

B

Backlight Compensation.....	23
Black&White Mode.....	26, 31
Blank Search.....	29

C

Camera Search.....	20
Card Photoshot.....	34
Card Playback.....	35
Charging the Battery.....	12
Color Temperature.....	25
Condensation.....	55
Continuous Photoshot.....	21
Cue Playback.....	28

D

Date/Time Indication.....	50
Date/Time Setting.....	19
Digital Effect.....	26, 27, 31, 32
Digital Electronic Image Stabilizer.....	22
Digital Still Picture.....	21
Digital Zoom.....	22
DPOF Setting.....	39
Dubbing.....	40, 41

E

Erasur Prevention Slider.....	13
-------------------------------	----

F

F Number.....	24
Fade.....	22
File Lock Setting.....	38
Folder Structure.....	47
Formatting.....	39

G

Gain-up Mode.....	26
-------------------	----

I

Index Search.....	30
Iris.....	24

J

Jog Playback.....	29
-------------------	----

L

LCD Monitor.....	14
Limited Warranty.....	64
Low Light Mode.....	23

M

Macro Close-up Function.....	21
Manual Focus.....	24
Mega-Pixel Still-Picture Recording.....	34
Memory Stop Function.....	57
Menu Screen.....	15
Microphone.....	53
Mirror Mode (Digital Effect).....	26, 31
Mix Mode.....	26, 31
Mosaic Mode.....	26, 31
Multi-Picture Mode.....	27, 32

N

Negative Mode.....	26, 31
--------------------	--------

P

Palmcorder Accessory.....	59
PhotoShot.....	21
PHOTOVU LINK.....	42, 43
Picture Search Mode.....	36
Picture-in-Picture Mode.....	27
Playback Digital Effect Functions.....	31, 32
Playback Zoom.....	31
Portrait Mode.....	23
Program AE.....	23
Progressive Photoshot.....	21

R

Recording Check.....	20
Recording Pause Mode.....	20
Recording Speed.....	19
Remote Controller.....	10, 11
Repeat Playback.....	28
Review Playback.....	28

S

SD Memory Card.....	47
Self-Recording.....	20
Sepia Mode.....	26, 31
Shutter Speed.....	24
Slide Playback.....	35
Slow Motion Playback.....	29
Solarization Mode.....	26, 31
Sound Volume.....	28
SP/LP Mode.....	19
Sports Mode.....	23
Spotlight Mode.....	23
Still Advance Playback.....	29
Strobe Mode.....	26, 31
Sub-Code.....	57
Surf & Snow Mode.....	23
Swing Mode.....	27, 32

T

Time Code.....	57
Title.....	37
Trailing Effect Mode.....	26, 31

U

USB Reader/Writer for SD Memory Card.....	45, 46, 47
---	------------

V

Variable Speed Search.....	28
Video Head Clogging.....	55
Viewfinder.....	14

W

White Balance.....	25, 57
Wind Noise Reduction.....	16
Wipe Mode.....	26, 31

Z

Zoom.....	21, 22
-----------	--------

Spanish Quick Use Guide/Guía española para el uso rápido

■ Para iniciar

1 Cargue la batería.

- Conecte el cable eléctrico de CA en el adaptador de CA y en la toma de corriente de CA.
- Coloque la batería con el adaptador de CA. (Eso hará empezar la carga).
- La batería estará cargada enteramente cuando se apague la luz de carga [CHARGE].
- Como la batería no se carga cuando el cable de CC. está conectado con el adaptador de CA, desconéctelo.

2 Acople la batería cargada con la videocámara.

- Levante el buscador y luego conéctelo con la batería cargada.

3 Active la videocámara.

- Desplace el interruptor ① a [ON]. (Se enciende la luz [CAMERA].)

4 Introduzca la cassette.

- Lleve la palanca ② a la derecha y tire hacia abajo para abrir la tapa.
- Introduzca la cassette.
- Oprima [PUSH/TO CLOSE] ③ para cargar la cassette.
- Cierre la tapa del asiento inferior.

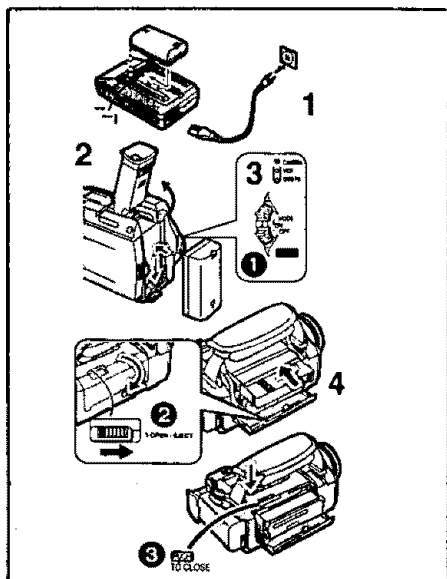

■ Para grabar

1 Ajuste el [OFF/ON/MODE] y ponga a [ON].

- Se enciende la luz [CAMERA]. ①

2 Oprima el pulsador de Inicio/Parada para grabar.

- Inicia la grabación.
- Después de que esté visualizado [RECORD], cambia a [REC]. ②

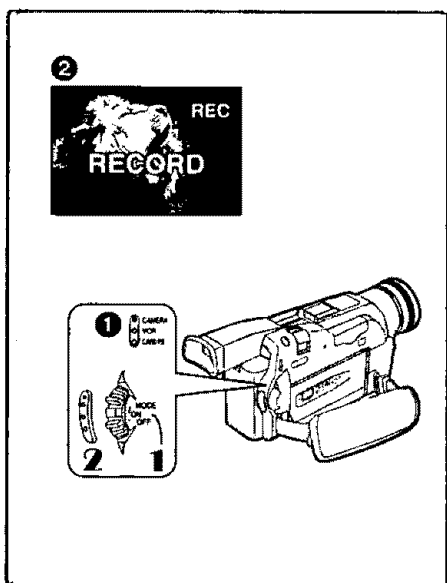

■ Para comprobar lo que ha sido grabado

1 Active el modo VCR, rebobine la cinta, ponga la cinta en playback.

- Desplace el interruptor ①. (Se enciende la luz [VCR].)
- Oprima el pulsador para rebobinar ②.
- Oprima el pulsador de actuación ③. (Empezará el playback)

2 Desactive la videocámara.

- Lleve el interruptor ① a [OFF].

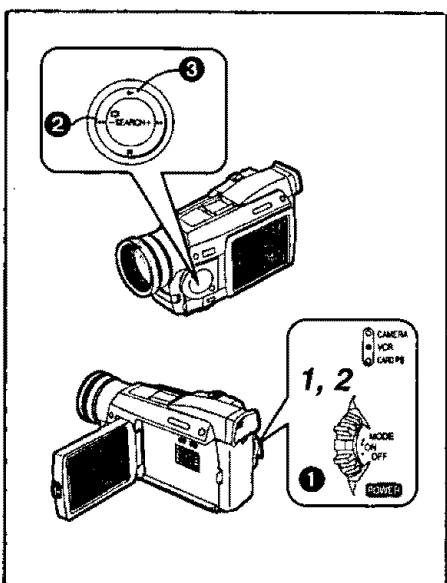

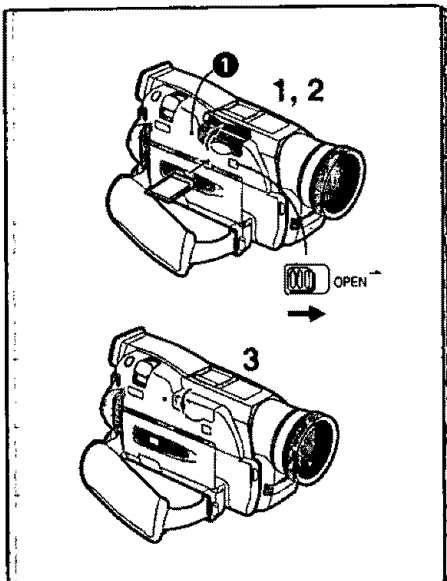

■ Para introducir una tarjeta de memoria.

Antes de introducir una tarjeta de memoria, asegúrese de que esté desactivada la videocámara.

- 1 Empuje la palanca [OPEN] hacia la derecha y abra el asiento de la tarjeta de memoria.
- 2 Manteniendo la tarjeta de memoria con su ángulo cortado hacia la derecha, introdúzcala en la ranura de tarjeta.
- 3 Cierre el asiento de la tarjeta.

• Mientras que está encendida la luz [ACCESS] ❶, nunca trate de abrir el asiento de la tarjeta, ya que eso podría dañar la tarjeta y originar un funcionamiento defectuoso a la videocámara.

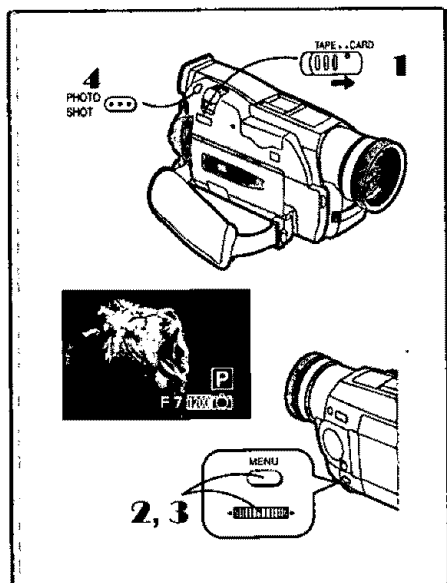

■ Para grabar en una tarjeta de memoria.

- 1 Lleve el selector [TAPE/CARD] a [CARD].
- 2 Ajuste el [PICTURE SIZE] en el submenú [CARD SETUP] a [1200x900] o bien a [640x480].
- 3 Ajuste [CAMERA FUNCTIONS] o [VCR FUNCTIONS] >> [CARD SETUP] >> [REC MODE] >> según la calidad deseada (FINE, NORMAL, ECONOMY).
- 4 Oprima el pulsador [PHOTO SHOT].

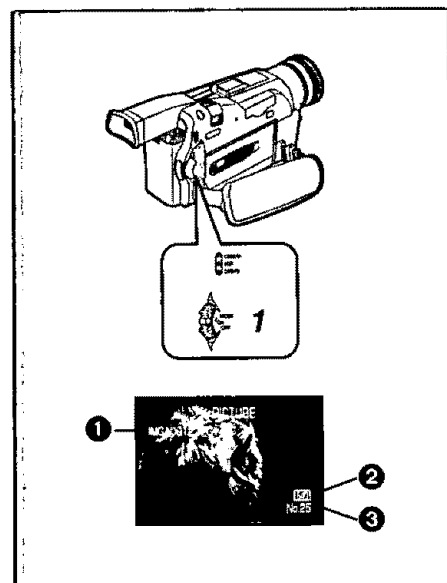

■ Para reproducir la imagen en la tarjeta de memoria.

- 1 Ajuste la videocámara según el modo de playback de tarjeta.

- Se enciende la luz [CARD P.B].
- En la tarjeta de memoria se visualiza fotograma que fue grabado por último.

- ❶ Nombre del fichero
- ❷ Dimensiones de la imagen
- ❸ El número de la imagen

**Panasonic Consumer Electronics Company,
Division of Matsushita Electric Corporation of America**

Executive Office:

One Panasonic Way, Secaucus, NJ 07094
(201) 348-7000

Panasonic Company East: 6749 Baymeadow Drive, Glen Burnie, MD 21060

Panasonic Company Central: 1707 North Randall Road, Elgin, IL 60123

Panasonic Company West: 6550 Katella Avenue, Cypress, CA 90630

Division of Matsushita Electric Corporation of America

Panasonic Sales Company ("PSC")

Division of Matsushita Electric of Puerto Rico, Inc.

San Gabriel Industrial Park, Ave. 65 de Infanteria, Km. 9.5, Carolina, PR 00984



LSQT0438B
F0301Ka1031(2500®)

