

PRO-FORM[®] XP 115

Model No. 831.28643.0

Serial No. _____

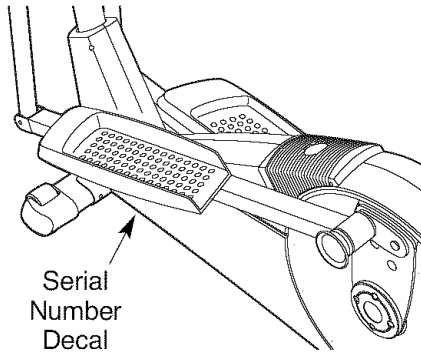

- Assembly
- Operation
- Maintenance
- Part List and Drawing

CAUTION

Read all precautions and instructions in this manual before using this equipment. Keep this manual for future reference.

ELLIPTICAL EXERCISER User's Manual

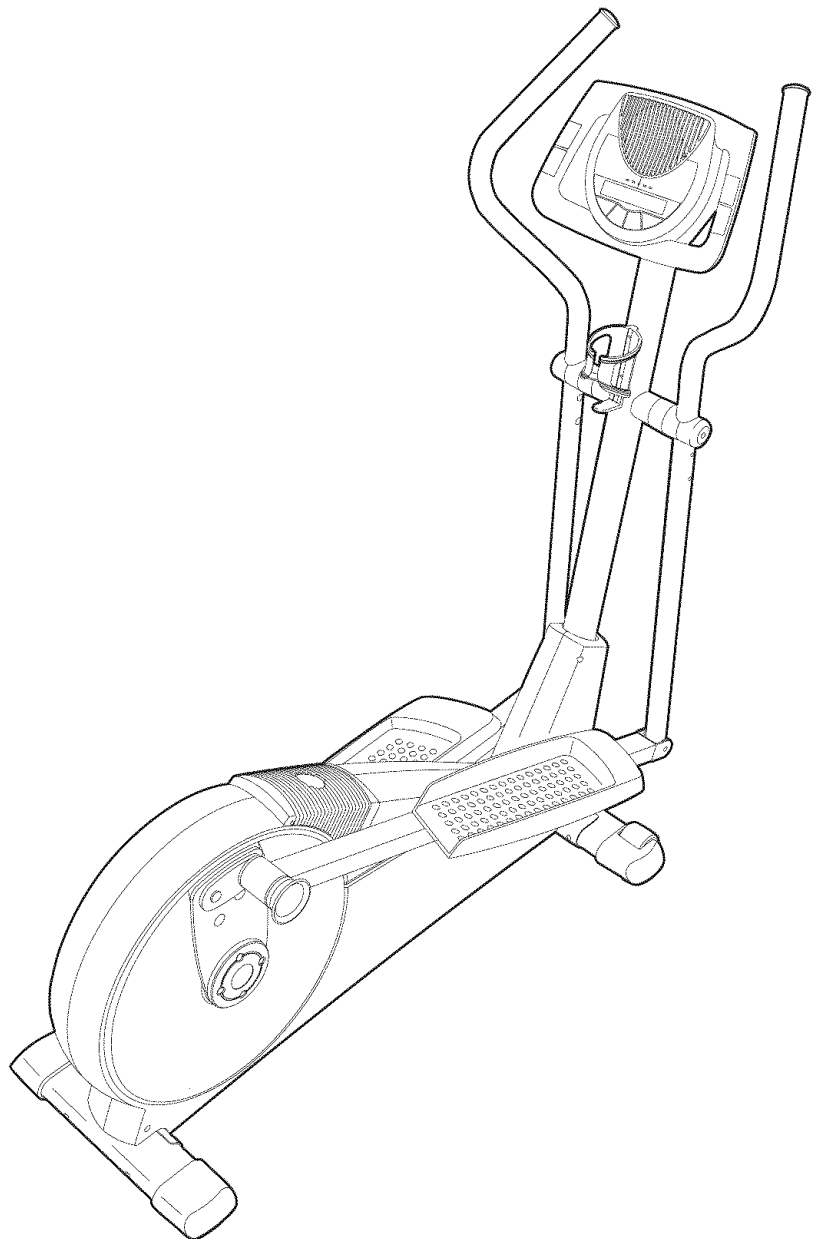

Sears, Roebuck and Co., Hoffman Estates, IL 60179

TABLE OF CONTENTS

IMPORTANT PRECAUTIONS	2
BEFORE YOU BEGIN	3
ASSEMBLY	4
HOW TO USE THE ELLIPTICAL EXERCISER	8
MAINTENANCE AND TROUBLESHOOTING	15
CONDITIONING GUIDELINES	16
PART LIST	17
EXPLODED DRAWING	18
HOW TO ORDER REPLACEMENT PARTS	Back Cover
90 DAY FULL WARRANTY	Back Cover

IMPORTANT PRECAUTIONS

⚠ WARNING: To reduce the risk of serious injury, read the following important precautions before using the elliptical exerciser.

1. Read all instructions in this manual and all warnings on the elliptical exerciser before using the elliptical exerciser. Use the elliptical exercise only as described in this manual.
2. It is the responsibility of the owner to ensure that all users of the elliptical exerciser are adequately informed of all precautions.
3. The elliptical exerciser is intended for home use only. Do not use the elliptical exerciser in a commercial, rental, or institutional setting.
4. Keep the elliptical exerciser indoors, away from moisture and dust. Place the elliptical exerciser on a level surface, with a mat beneath it to protect the floor or carpet. Make sure that there is enough clearance around the elliptical exerciser to mount, dismount, and use it.
5. Inspect and properly tighten all parts regularly. Replace any worn parts immediately.
6. Keep children under 12 and pets away from the elliptical exerciser at all times.
7. The elliptical exerciser should not be used by persons weighing more than 250 pounds.
8. Wear appropriate exercise clothes when using the elliptical exerciser. Always wear athletic shoes for foot protection while exercising.
9. Hold the handgrip pulse sensor or the handlebars when mounting, dismounting, or using the elliptical exerciser.
10. The pulse sensor is not a medical device. Various factors may affect the accuracy of heart rate readings. The pulse sensor is intended only as an exercise aid in determining heart rate trends in general.
11. Keep your back straight while using the elliptical exerciser; do not arch your back.
12. If you feel pain or dizziness while exercising, stop immediately and cool down.
13. When you stop exercising, allow the pedals to slowly come to a stop.

⚠ WARNING: Before beginning this or any exercise program, consult your physician. This is especially important for persons over the age of 35 or persons with pre-existing health problems. Read all instructions before using. Sears assumes no responsibility for personal injury or property damage sustained by or through the use of this product.

BEFORE YOU BEGIN

Congratulations for selecting the new PROFORM® XP 115 elliptical exerciser. The PROFORM XP 115 is an incredibly smooth exerciser that moves your feet in a natural elliptical path, minimizing the impact on your knees and ankles. The unique XP 115 features adjustable resistance and a state-of-the-art console to help you get the most from your exercise.



tions after reading this manual, call 1-800-4-MY-HOME® (1-800-469-4663). To help us assist you, please note the product model number and serial number before calling. The model number is 831.28643.0. The serial number can be found on a decal attached to the elliptical exerciser (see the front cover of this manual for the location of the decal).

For your benefit, read this manual carefully before you use the elliptical exerciser. If you have ques-

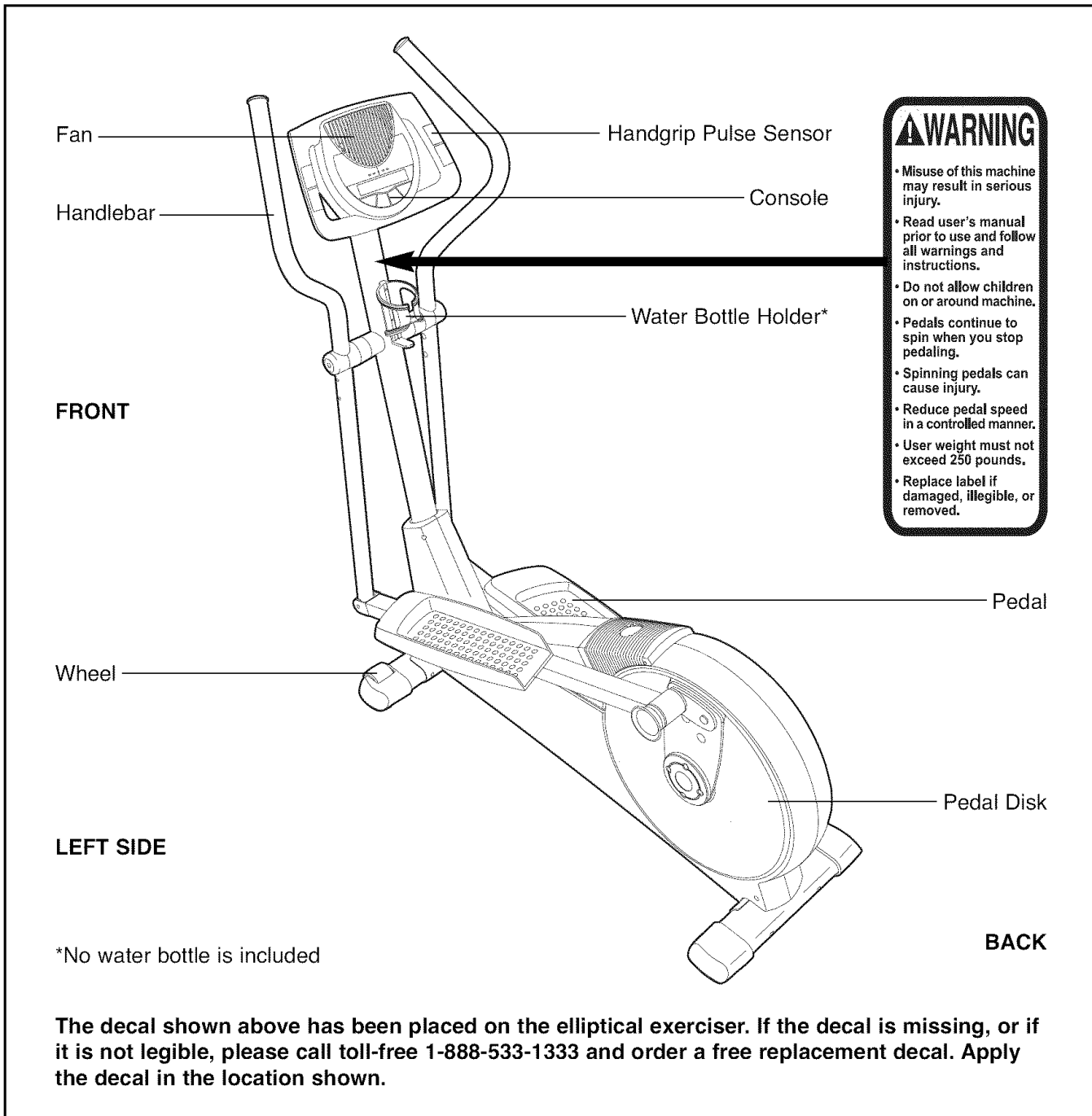

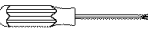

Before reading further, please familiarize yourself with the parts that are labeled in the drawing below.

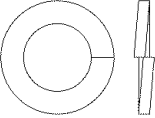
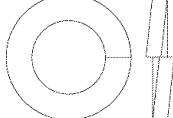
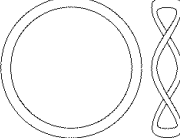
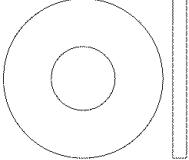
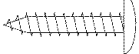
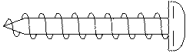
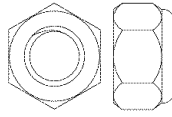
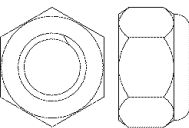
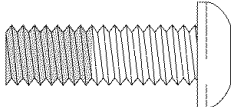
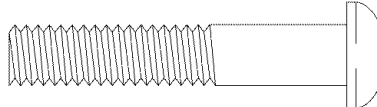
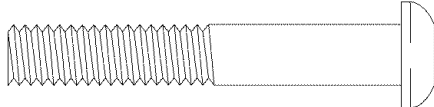
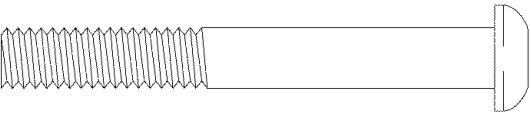

ASSEMBLY

Assembly requires two persons. Place all parts of the elliptical exerciser in a cleared area and remove the packing materials. Do not dispose of the packing materials until assembly is completed. **Assembly requires the included hex keys as well as a phillips screwdriver** , **an adjustable wrench** , **and a rubber mallet** .

As you assemble the elliptical exerciser, use the drawings below to identify small parts. The number in parentheses below each drawing is the key number of the part, from the PART LIST on page 17. The second number is the quantity needed for assembly. **Note: Some small parts may have been pre-assembled. If a part is not in the parts bag, check to see if it has been pre-assembled. If a part is missing, call toll-free 1-888-533-1333.**

			
M8 Split Washer (100)-4	M10 Split Washer (70)-2	Wave Washer (95)-2	M8 Large Washer (53)-10
			
M4 x 16mm Screw (66)-4	M4 x 22mm Screw (91)-2	M8 Nylon Locknut (46)-8	M10 Nylon Locknut (29)-4
			
M8 x 25mm Patch Screw (22)-2	M8 x 45mm Button Bolt (50)-4	M8 x 50mm Button Screw (89)-4	
			
M8 x 65mm Button Screw (99)-4	M10 x 52mm Bolt Set (27)-2		
			
	M10 x 112mm Carriage Bolt (34)-4		
			
	M10 x 88mm Button Screw (63)-2		

1. Identify the Front Stabilizer (3). While another person lifts the front of the Frame (1), attach the Front Stabilizer to the Frame with two M10 x 112mm Carriage Bolts (34) and two M10 Nylon Locknuts (29). **Make sure that the Front Stabilizer is turned so the Wheels (32) are not touching the floor.**

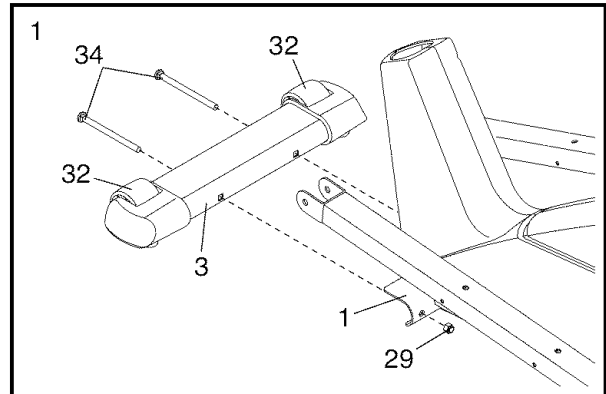

2. While another person lifts the back of the Frame (1), attach the Rear Stabilizer (4) to the Frame with two M10 x 112mm Carriage Bolts (34) and two M10 Nylon Locknuts (29).

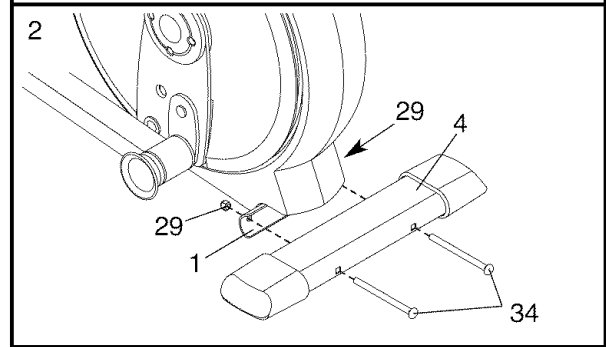

3. While another person holds the Upright (2) in the position shown, connect the Upper Wire Harness (86) to the Lower Wire Harness (87). **Carefully pull the upper end of the Upper Wire Harness to remove any slack. While holding the upper end of the Upper Wire Harness, insert the Upright into the Frame (1). Do not pinch the Wire Harnesses.**

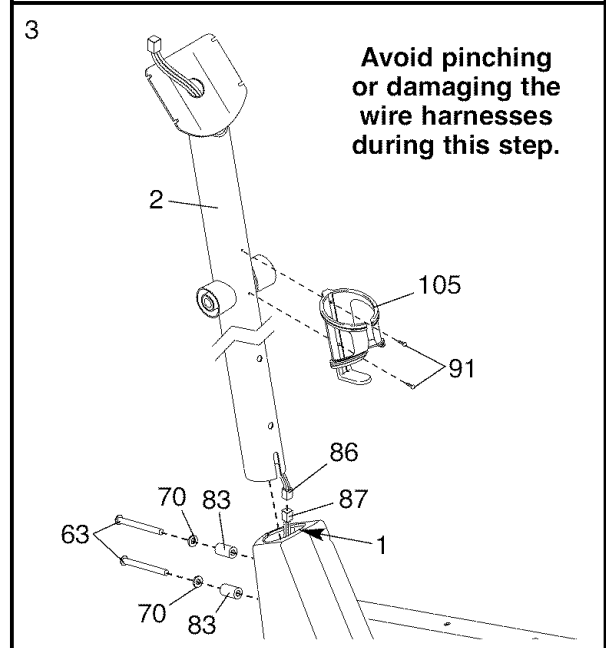

Slide an M10 Split Washer (70) and a Frame Spacer (83) onto each of the two M10 x 88mm Button Screws (63). Insert the Button Screws into the Frame (1) and the Upright (2). **Make sure that the concave ends of the Frame Spacers are facing the Frame. Do not tighten the Button Screws yet.**

Attach the Water Bottle Holder (105) to the Upright (2) with two M4 x 22mm Screws (91).

4. The Console (5) requires four 1.5V "D" batteries (not included); alkaline batteries are recommended. Remove the battery cover from the Console. Next, insert four batteries into the battery compartments. **Make sure that the batteries are oriented as shown by the diagrams inside the battery compartments.** Then, replace the battery cover.

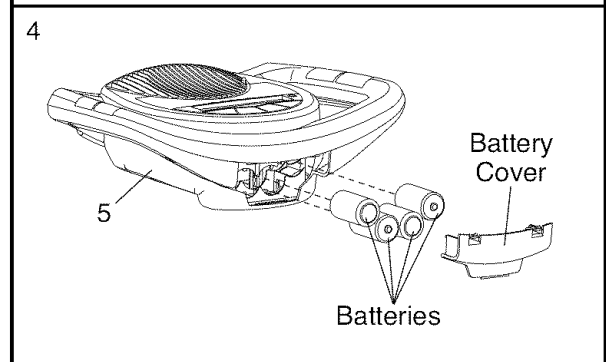

- While another person holds the Console (5) near the Upright (2), connect the wire harness on the Console to the Upper Wire Harness (86). Insert the excess wire harness into the Upright. Next, attach the Console to the Upright with four M4 x 16mm Screws (66). **Be careful to avoid pinching the wire harnesses.**

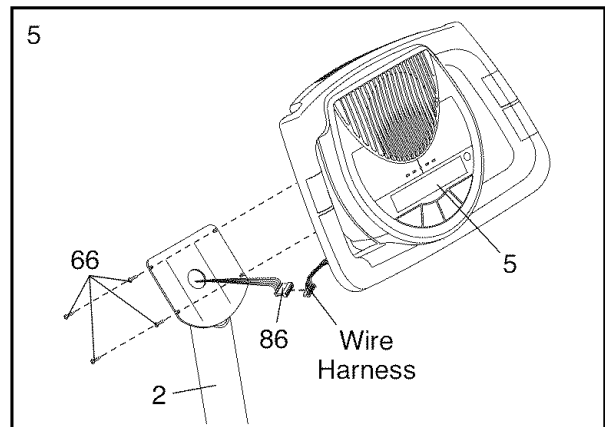

- Identify the Left Handlebar (9), which is marked with a sticker. Insert the Left Handlebar into one of the Handlebar Legs (79); **make sure that the Handlebar Leg is turned so the hexagonal holes are oriented as indicated.** Attach the Left Handlebar to the Handlebar Leg with two M8 x 45mm Button Bolts (50) and two M8 Nylon Locknuts (46). **Make sure that the Nylon Locknuts are set inside the hexagonal holes. Do not tighten the Button Bolts yet.**

Apply a generous amount of the included grease to the Pivot Axle (97) and to two M8 Large Washers (53). Next, insert the Pivot Axle into the Upright (2) and center it. Apply more grease to both ends of the Pivot Axle.

Slide a Handlebar Spacer (25) onto the short tube on the Left Handlebar (9), and rotate the Handlebar Spacer so the small arrow is pointing toward the floor. Next, slide the Left Handlebar onto the left end of the Pivot Axle (97). Finger tighten an M8 x 25mm Patch Screw (22) with an M8 Large Washer (53) and a Wave Washer (95) into the end of the Pivot Axle. Then, attach a Handlebar Cap (23) by pressing its small tabs into the Handlebar Spacer.

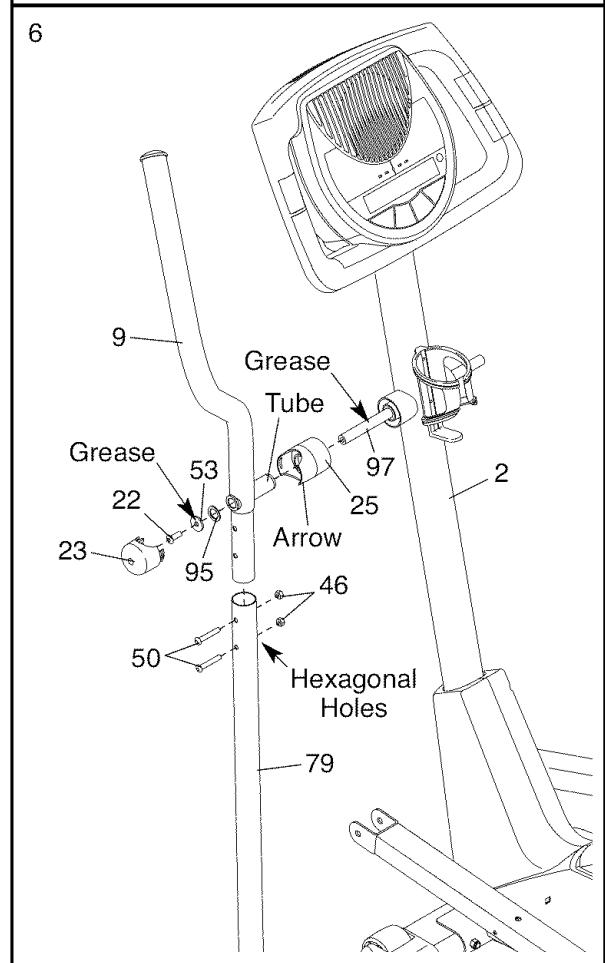

Assemble the Right Handlebar (not shown) and the other Handlebar Leg (not shown) in the same way.

Now, tighten both M8 x 25mm Patch Screws (22) at the same time.

- Apply a thin film of grease to the shaft of an M10 x 52mm Bolt Set (27) and to the surfaces of the two Leg Bushings (28) in the left Handlebar Leg (79).

Next, attach the left Handlebar Leg (79) to the Left Pedal Arm (14) with the M10 x 52mm Bolt Set (27). **Do not overtighten the Bolt Set; the left Handlebar Leg must be able to pivot freely.**

Attach the right Handlebar Leg (79) to the Right Pedal Arm (103) in the same way.

See step 3. Tighten the M10 x 88mm Button Screws (63). See step 6. Tighten the M8 x 45mm Button Bolts (50) in the Handlebar Legs (79).

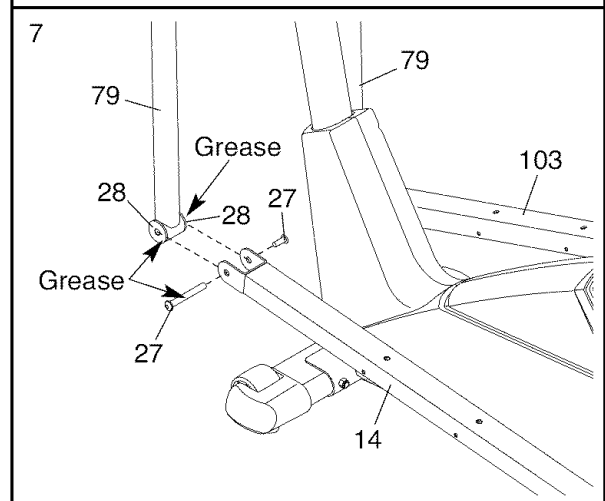

8. Attach a Pedal Bracket (16) to the Left Pedal Arm (14) with two M8 x 65mm Button Screws (99), two M8 Large Washers (53), and two M8 Nylon Locknuts (46).

Identify the Left Pedal (13). Attach the Left Pedal to the Left Pedal Arm (14) with two M8 x 50mm Button Screws (89), two M8 Split Washers (100) and two M8 Large Washers (53).

Attach the other Pedal Bracket (not shown) and the Right Pedal (12) to the Right Pedal Arm (103) in the same way.

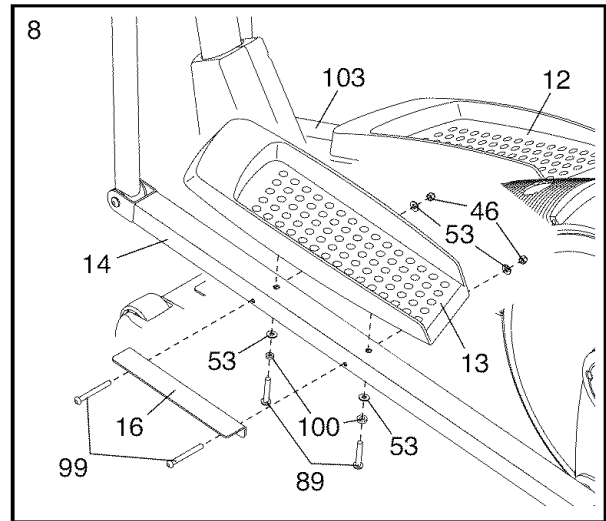

9. **Make sure that all parts of the elliptical exerciser are properly tightened.** Note: Some hardware may be left over after assembly is completed. To protect the floor or carpet from damage, place a mat under the elliptical exerciser.

HOW TO USE THE ELLIPTICAL EXERCISER

HOW TO EXERCISE ON THE ELLIPTICAL EXERCISER

To mount the elliptical exerciser, hold the handgrip pulse sensor and step onto the pedal that is in the lower position. Next, step onto the other pedal. Push the pedals until they begin to move with a continuous motion. **Note: The pedal discs can turn in either direction. It is recommended that you move the pedal discs in the direction shown by the arrow below; however, for variety, you can turn the pedal discs in the opposite direction.**

To dismount the elliptical exerciser, wait until the pedals come to a complete stop. **Note: The elliptical exerciser does not have a free wheel; the pedals will continue to move until the flywheel stops.** When the pedals are stationary, step off the higher pedal first. Then, step off the lower pedal.

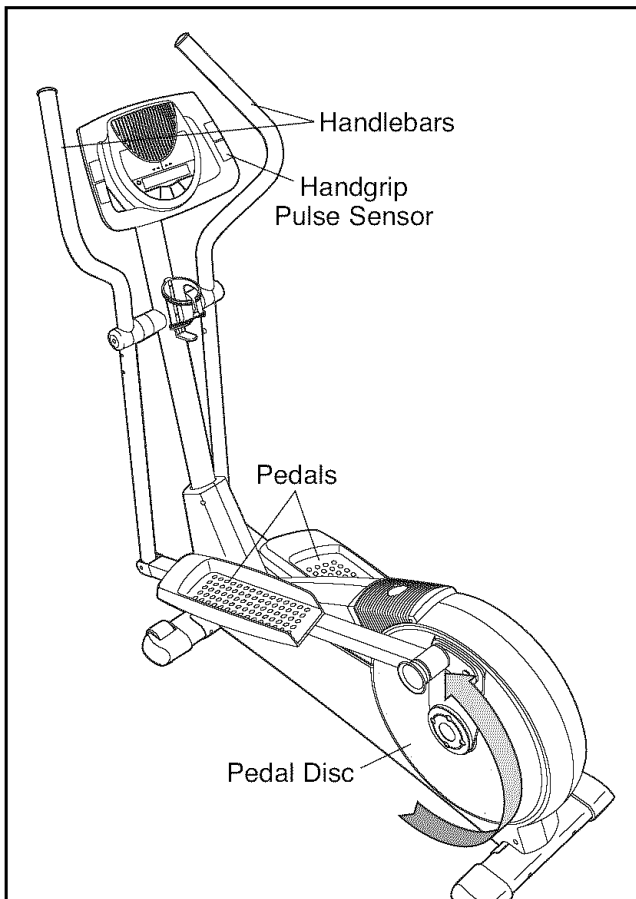

HOW TO USE THE HANDLEBARS

The handlebars are designed to add upper-body exercise to your workouts. Push and pull the handlebars as you exercise to work your arms, shoulders, and back.

To exercise only your lower body, hold the handgrip pulse sensor as you exercise.

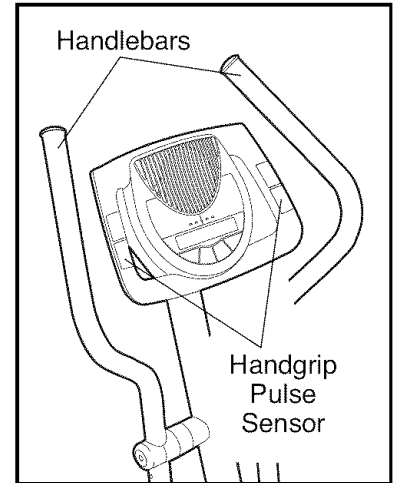

HOW TO ADJUST THE STRIDE OF THE ELLIPTICAL EXERCISER

To adjust the stride of the elliptical exerciser, first pull one of the adjustment knobs until the adjustment bracket will pivot freely. Pivot the adjustment bracket to align the adjustment knob with one of the three holes in the crank arm, and gently release the knob. Then, pivot the adjustment bracket back and forth slightly to make sure that the adjustment pin is engaged in one of the holes in the crank arm.

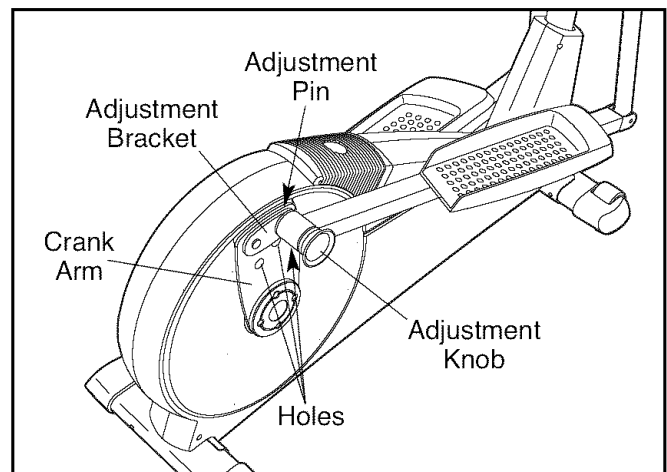

Adjust the other side of the elliptical exerciser in the same way.

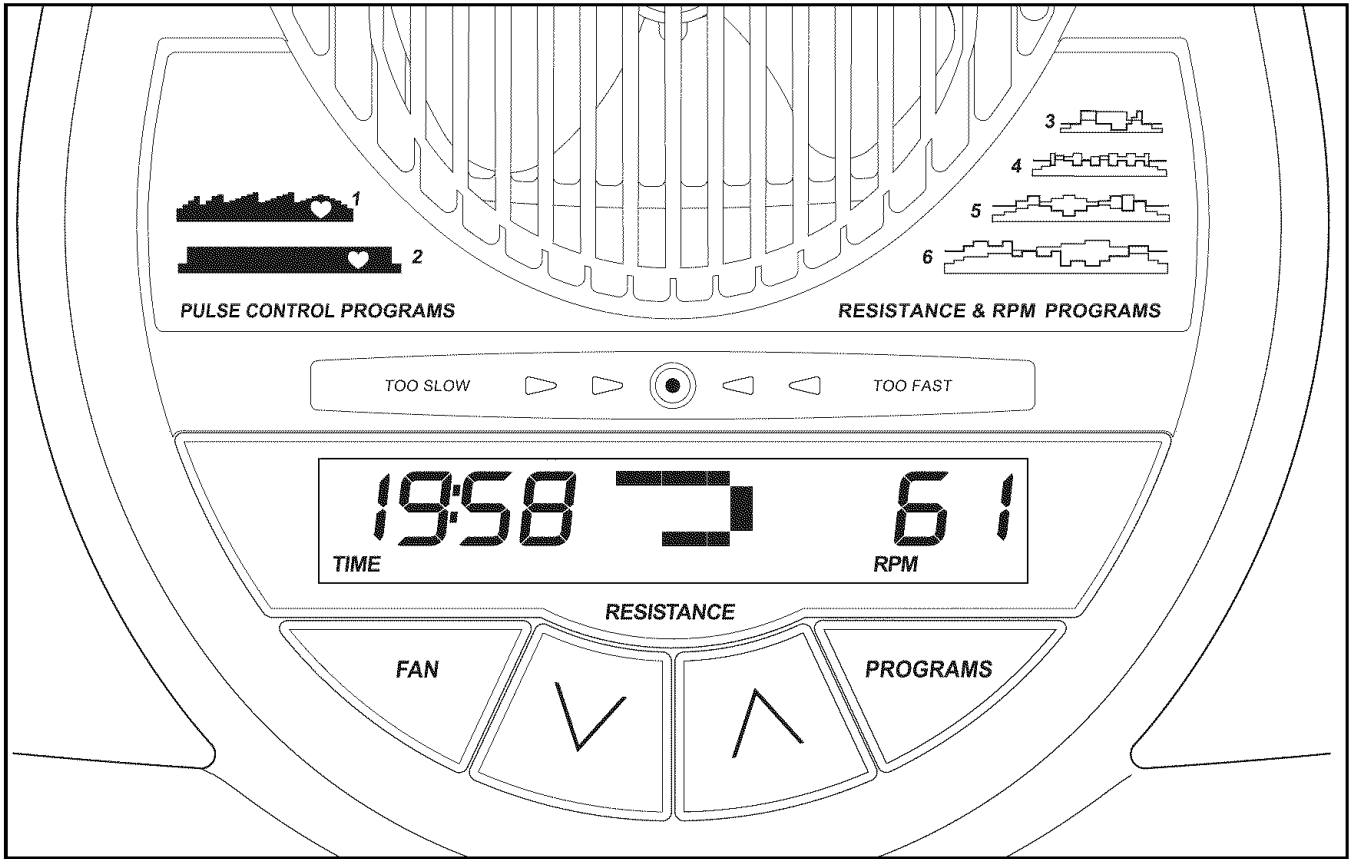

FEATURES OF THE CONSOLE

The advanced console offers an array of features designed to make your workouts more effective and enjoyable.

When the manual mode of the console is selected, you can change the resistance of the pedals with the touch of a button. As you exercise, the console will provide continuous exercise feedback. You can even monitor your heart rate using the handgrip pulse sensor.

The console also offers two pulse control programs and four resistance & rpm programs. During your workout,

each pulse control program automatically controls the resistance of the pedals and prompts you to increase or decrease your pedaling pace to keep your heart rate near a target heart rate setting. Each resistance & rpm program automatically changes the resistance of the pedals and prompts you to vary your pedaling pace as it guides you through an effective workout.

To use the manual mode of the console, follow the steps beginning on page 10. **To use a pulse control program**, see page 12. **To use a resistance & rpm program**, see page 14.

Note: If there is a sheet of clear plastic on the face of the console, remove the plastic.

HOW TO USE THE MANUAL MODE

1 Press the Resistance decrease button or begin pedaling to turn on the console.

A moment after the console is turned on, the display will light.

2 Select the manual mode.

Each time the console is turned on, the manual mode will be selected automatically. If you have previously selected a program, return to the manual mode by pressing the Programs button repeatedly until the display appears as shown below.

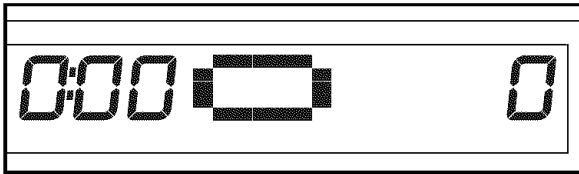

3 Begin pedaling and change the resistance of the pedals as desired.

As you pedal, change the resistance of the pedals by pressing the Resistance increase and decrease buttons repeatedly. There are ten resistance levels. Note: After you press the buttons, it will take a moment for the pedals to reach the selected resistance level.

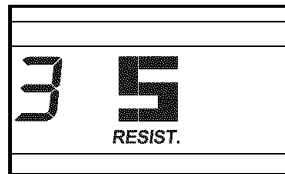

During your workout, the Pace Coach will prompt you to maintain a target pace of 50 revolutions per minute (rpm). If you choose, increase your pace when one of the "Too Slow" arrows lights and decrease your pace when one of the "Too Fast" arrows lights. When the center indicator lights, maintain your current pace. **Important: The target pace is intended only to provide motivation. Your actual pace may be slower or faster than the target pace. Make sure to exercise at a pace that is comfortable for you.**

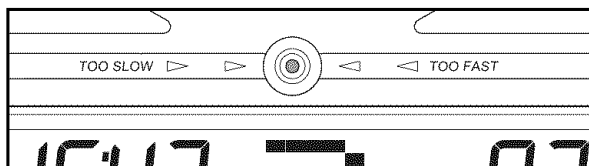

4 Monitor your progress with the display.

The left side of the display—The left side of the display will show the elapsed time, the approximate number of grams of carbs you have burned, and the approximate number of calories you have burned. Note: When a preset program is selected (except for pulse control program 2), the display will show the time remaining in the program instead of the elapsed time.



The left side of the display will also show your heart rate when you use the handgrip pulse sensor (see step 5 on page 11).

The center of the display—When the manual mode is selected, the center of the display will show a track that represents 640 revolutions. As you exercise, indicators will appear in succession around the track until the entire track appears. The track will then disappear and the indicators will again begin to appear in succession.

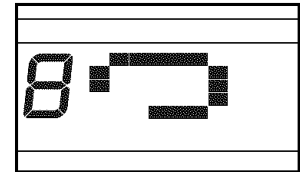

The center of the display will also show the resistance setting of the pedals for a few seconds each time the resistance setting changes.

The right side of the display—The right side of the display will show the distance (total revolutions) you have pedaled and your pedaling pace (revolutions per minute [rpm]).

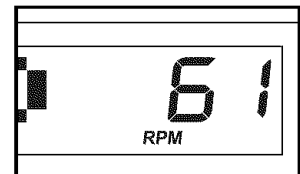

5 Measure your heart rate if desired.

If there are sheets of clear plastic on the metal contacts on the handgrip pulse sensor, peel off the plastic. To measure your heart rate, hold the handgrip pulse sensor, with your palms resting on the metal contacts. **Avoid moving your hands or gripping the contacts too tightly.**

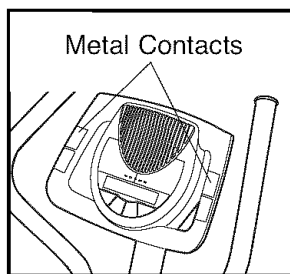

When your pulse is detected, a heart-shaped symbol will flash in the left side of the display each time your heart beats, one or two dashes will appear, and then your heart rate will be shown. For the most accurate heart rate reading, hold the contacts for at least 15 seconds. Note: If you continue to hold the handgrip pulse sensor, the display will show your heart rate for up to 30 seconds. The display will then show your heart rate along with the other modes.



If your heart rate is not shown, make sure that your hands are positioned as described. Be care-

ful not to move your hands excessively or to squeeze the metal contacts too tightly. For optimal performance, clean the metal contacts using a soft cloth; **never use alcohol, abrasives, or chemicals.**

6 Turn on the fan if desired.

To turn on the fan at low speed, press the Fan button. To turn on the fan at high speed, press the button a second time. To turn off the fan, press the button a third time. Note: If the pedals are not moved for a few minutes, the fan will automatically turn off to conserve the batteries.

Pivot the thumb tab on the right side of the fan to adjust the angle of the fan.

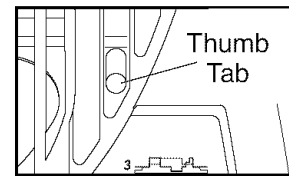

7 When you are finished exercising, the console will automatically turn off.

If the pedals are not moved for several seconds, a tone will sound and the console will pause.

If the pedals are not moved for about five minutes, the console will turn off and the display will be reset.

HOW TO USE A PULSE CONTROL PROGRAM

- 1 Press the Resistance decrease button or begin pedaling to turn on the console.**

A moment after the console is turned on, the display will light.

- 2 Select one of the pulse control programs.**

Press the Programs button repeatedly until "P 1" or "P 2" appears in the right side of the display.

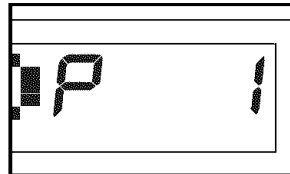

If pulse control program 1 is selected, a profile of the target heart rate settings for the program will scroll across the center of the display.

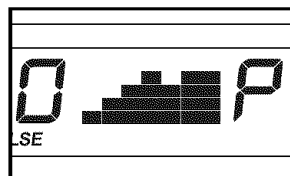

If pulse control program 2 is selected, a pulse symbol will appear in the center of the display. Each time a heartbeat is detected while you are using the handgrip pulse sensor, the pulse symbol will reappear.

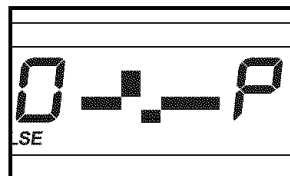

- 3 Enter a target heart rate setting.**

If pulse control program 1 is selected, the maximum target heart rate setting of the program will flash in the display. If desired, press the Resistance increase and decrease buttons to change the maximum target heart rate setting (see EXERCISE INTENSITY on page 16). If you change the maximum target heart rate setting, the intensity level of the entire program will change.

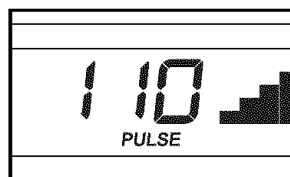

If pulse control program 2 is selected, the target heart rate setting for the program will flash in the display. If desired, press the Resistance increase and decrease buttons to change the target heart rate setting (see EXERCISE INTENSITY on page 16).

- 4 Hold the handgrip pulse sensor.**

It is not necessary to hold the handgrip pulse sensor continuously during a pulse control program; however, you should hold the handgrip pulse sensor frequently for the program to operate properly. **Each time you hold the handgrip pulse sensor, keep your hands on the metal contacts for at least 30 seconds.**

- 5 Begin pedaling to start the program.**

Pulse control program 1 is divided into 30 one-minute segments. One target heart rate setting is programmed for each segment. Note: The same target heart rate setting may be programmed for two or more consecutive segments.

The target heart rate setting for the first segment will be shown in the flashing Current Segment column in the center of the display. The target heart rate settings for the next four segments will be shown in the columns to the right.

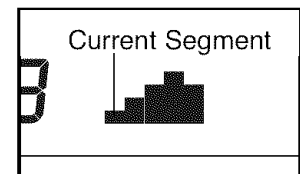

When only three seconds remain in the first segment of the program, both the Current Segment column and the column to the right will flash, a series of tones will sound, and *all target heart rate settings will move one column to the left*. The target heart rate setting for the second segment will then be shown in the flashing Current Segment column.

Pulse control program 2 is divided into 40 one-minute segments. The same target heart rate setting is programmed for all segments. Note: For a shorter workout, stop exercising or select a different program before the program ends.

During both pulse control programs, the console will regularly compare your heart rate to the target heart rate setting. If your heart rate is too far below or above the target heart rate setting, the resistance of the pedals will automatically increase or decrease to bring your heart rate closer to the target heart rate setting.

After the first minute of the program, the Pace Coach will prompt you to maintain a consistent pedaling pace. When one of the “Too Slow” arrows lights, increase your pace. When one of the “Too Fast” arrows lights, decrease your pace. When the center indicator lights, maintain your current pace.

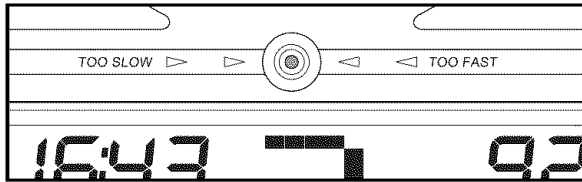

Important: The target heart rate settings are intended only to provide motivation. Your actual heart rate may be slower than the target heart rate settings. Make sure to exercise at a pace that is comfortable for you.

Note: During the program, you can manually override the resistance setting for the current segment, if desired, by pressing the increase and decrease buttons. However, when the console compares your heart rate to the target heart rate setting, the resistance of the pedals may automatically increase or decrease to bring your heart rate closer to the target heart rate setting.

If you stop pedaling for several seconds, a tone will sound and the program will pause. To restart the program, simply resume pedaling.

6 Monitor your progress with the display.

See step 4 on page 10.

7 Turn on the fan if desired.

See step 6 on page 11.

8 When you are finished exercising, the console will automatically turn off.

See step 7 on page 11.

HOW TO USE A RESISTANCE & RPM PROGRAM

1 Press the Resistance decrease button or begin pedaling to turn on the console.

A moment after the console is turned on, the display will light.

2 Select one of the resistance & rpm programs.

Press the Programs button repeatedly until "P 3," "P 4," "P 5," or "P 6" appears in the right side of the display. When a resistance & rpm program is selected, a profile of the resistance settings of the program will scroll across the center of the display. The left side of the display will show how long the program will last.

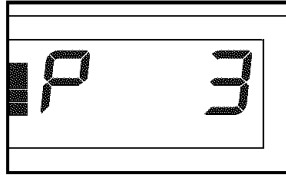

3 Begin pedaling to start the program.

Each program is divided into several one-minute segments. One resistance setting and one pace setting are programmed for each segment. Note: The same resistance setting and/or pace setting may be programmed for two or more consecutive segments.

The resistance setting for the first segment will be shown in the flashing Current Segment column in the center of the display. (Note: The pace settings are not shown in the display.) The resistance settings for the next four segments will be shown in the columns to the right.

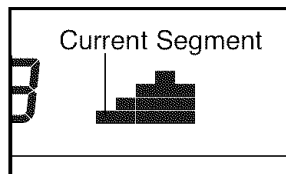

As you exercise, the Pace Coach will prompt you to keep your pedaling pace near the pace setting for the current segment. When one of the "Too Slow" arrows lights, increase your pace. When one of the "Too Fast" arrows lights, decrease your pace. When the center indicator lights, maintain your current pace.

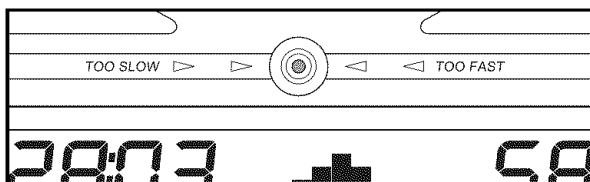

Important: The pace settings are intended only to provide motivation. Your actual pace may be slower than the pace settings. Make sure to exercise at a pace that is comfortable for you.

When only three seconds remain in the first segment of the program, both the Current Segment column and the column to the right will flash, a series of tones will sound, and *all resistance settings will move one column to the left*. The resistance setting for the second segment will then be shown in the flashing Current Segment column, and the resistance of the pedals will change to the resistance setting for the second segment. Note: If all of the indicators in the Current Segment column are lit after the resistance settings have moved to the left, *the resistance settings may move downward* so only the highest indicators appear in the matrix.

The program will continue until the resistance setting for the last segment is shown in the Current Segment column and the last segment ends.

Note: During the program, you can override the resistance setting for the current segment, if desired, by pressing the increase or decrease button. However, when the next segment begins, the resistance will change if a different resistance setting is programmed for the next segment.

If you stop pedaling for several seconds, a tone will sound and the program will pause. To restart the program, simply resume pedaling.

4 Monitor your progress with the display.

See step 4 on page 10.

5 Measure your heart rate if desired.

See step 5 on page 11.

6 Turn on the fan if desired.

See step 6 on page 11.

7 When you are finished exercising, the console will automatically turn off.

See step 7 on page 11.

MAINTENANCE AND TROUBLESHOOTING

Inspect and tighten all parts of the elliptical exerciser regularly. Replace any worn parts immediately.

To clean the elliptical exerciser, use a damp cloth and a small amount of mild soap. **Important: To avoid damaging the console, keep liquids away from the console and keep the console out of direct sunlight.**

BATTERY REPLACEMENT

If the console displays become dim, the batteries should be replaced; most console problems are the result of low batteries. See assembly step 4 on page 5 for replacement instructions.

HOW TO LEVEL THE ELLIPTICAL EXERCISER

After moving the elliptical exerciser to the location where it will be used, make sure that the ends of both stabilizers are touching the floor. If the elliptical exerciser rocks slightly

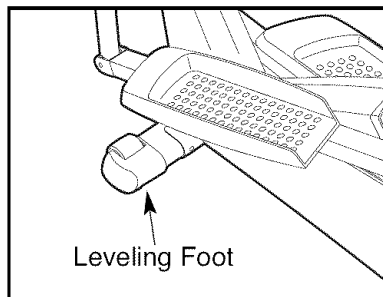

during use, turn one or both of the leveling feet under the front stabilizer until the rocking motion is eliminated.

HANDGRIP PULSE SENSOR TROUBLESHOOTING

- Avoid moving your hands while using the handgrip pulse sensor. Excessive movement may interfere with heart rate readings.
- Do not hold the metal contacts too tightly; doing so may interfere with heart rate readings.
- For the most accurate heart rate reading, hold the metal contacts for about 30 seconds.
- For optimal performance of the handgrip pulse sensor, keep the metal contacts clean. The contacts can be cleaned with a soft cloth—never use alcohol, abrasives, or chemicals.

CONDITIONING GUIDELINES

WARNING:



Before beginning this or any exercise program, consult your physician. This is especially important for persons over the age of 35 or persons with pre-existing health problems.

The pulse sensor is not a medical device. Various factors may affect the accuracy of heart rate readings. The pulse sensor is intended only as an exercise aid in determining heart rate trends in general.

The following guidelines will help you to plan your exercise program. Remember that proper nutrition and adequate rest are essential for successful results.

EXERCISE INTENSITY

Whether your goal is to burn fat or to strengthen your cardiovascular system, the key to achieving the desired results is to exercise with the proper intensity. The proper intensity level can be found by using your heart rate as a guide. The chart below shows recommended heart rates for fat burning, maximum fat burning, and cardiovascular (aerobic) exercise.

165	155	145	140	130	125	115	
145	138	130	125	118	110	103	
125	120	115	110	105	95	90	
20	30	40	50	60	70	80	

To find the proper heart rate for you, first find your age at the bottom of the chart (ages are rounded off to the nearest ten years). Next, find the three numbers above your age. The three numbers are your “training zone.” The lower two numbers are recommended heart rates for fat burning; the highest number is the recommended heart rate for aerobic exercise.

Fat Burning

To burn fat effectively, you must exercise at a relatively low intensity level for a sustained period of time.

During the first few minutes of exercise, your body uses easily accessible *carbohydrate* calories for energy. Only after the first few minutes of exercise does your body begin to use stored *fat* calories for energy. If your goal is to burn fat, adjust the intensity of your exercise until your heart rate is near the lowest number in your training zone as you exercise.

For maximum fat burning, adjust the intensity of your exercise until your heart rate is near the middle number in your training zone as you exercise.

Aerobic Exercise

If your goal is to strengthen your cardiovascular system, your exercise must be “aerobic.” Aerobic exercise is activity that requires large amounts of oxygen for prolonged periods of time. This increases the demand on the heart to pump blood to the muscles, and on the lungs to oxygenate the blood. For aerobic exercise, adjust the intensity of your exercise until your heart rate is near the highest number in your training zone as you exercise.

WORKOUT GUIDELINES

Each workout should include the following three parts:

A warm-up, consisting of 5 to 10 minutes of stretching and light exercise. A proper warm-up increases your body temperature, heart rate, and circulation in preparation for exercise.

Training zone exercise, consisting of 20 to 30 minutes of exercising with your heart rate in your training zone. Note: During the first few weeks of your exercise program, do not keep your heart rate in your training zone for longer than 20 minutes.

A cool-down, with 5 to 10 minutes of stretching. This will increase the flexibility of your muscles and will help to prevent post-exercise problems.

EXERCISE FREQUENCY

To maintain or improve your condition, complete three workouts each week, with at least one day of rest between workouts. After a few months of regular exercise, you may complete up to five workouts each week if desired. The key to success is to make exercise a regular and enjoyable part of your everyday life.

PART LIST—Model No. 831.28643.0

R0806A

Key No.	Qty.	Description	Key No.	Qty.	Description
1	1	Frame	55	1	Motor
2	1	Upright	56	1	Belt
3	1	Front Stabilizer	57	2	Hub
4	1	Rear Stabilizer	58	4	Hub Spacer
5	1	Console	59	4	M6 Nylon Locknut
6	1	Left Side Shield	60	4	M6 Nut
7	1	Right Side Shield	61	4	M5 Nylon Locknut
8	2	Pedal Disc	62	4	M5 x 12mm Bolt
9	1	Left Handlebar	63	2	M10 x 88mm Button Screw
10	1	Right Handlebar	64	2	M4 x 6mm Self-tapping Screw
11	2	Foam Grip	65	2	Adjustment Bracket Screw
12	1	Right Pedal	66	6	M4 x 16mm Screw
13	1	Left Pedal	67	4	M4 x 25mm Screw
14	1	Left Pedal Arm	68	1	Right Front Endcap
15	2	Pin Spacer	69	1	Reed Switch Clamp
16	2	Pedal Bracket	70	2	M10 Split Washer
17	2	Adjustment Pin	71	2	Handlebar Endcap
18	4	Pedal Arm Bushing	72	2	Leveling Foot
19	2	Adjustment Spring	73	1	M5 x 16mm Screw
20	2	Adjustment Bracket	74	8	M4 x 19mm Screw
21	2	Snap Ring	75	2	M6 Eyebolt
22	2	M8 x 25mm Patch Screw	76	1	Resistance Spring
23	2	Handlebar Cap	77	1	Reed Switch
24	6	Handlebar Bushing	78	1	Reed Switch Bracket
25	2	Handlebar Spacer	79	2	Handlebar Leg
26	2	Upright Spacer	80	1	Side Shield Cover
27	2	M10 x 52mm Bolt Set	81	1	“U” Bracket
28	4	Leg Bushing	82	8	Cover Screw
29	4	M10 Nylon Locknut	83	2	Frame Spacer
30	1	Upright Bushing	84	4	M4 x 12mm Round Head Screw
31	1	Left Front Endcap	85	1	Resistance Cable
32	2	Wheel	86	1	Upper Wire Harness
33	2	M6 x 72mm Button Screw	87	1	Lower Wire Harness
34	4	M10 x 112mm Carriage Bolt	88	2	Pedal Arm Sleeve
35	2	Rear Stabilizer Endcap	89	4	M8 x 50mm Button Screw
36	1	Left Crank Arm	90	4	Motor Washer
37	1	Pulley	91	2	M4 x 22mm Screw
38	1	Right Crank Arm	92	2	Inner Pedal Arm Sleeve
39	1	Crank	93	3	M6 Washer
40	2	Crank Bearing	94	4	Large Snap Ring
41	1	Flywheel	95	2	Wave Washer
42	2	Flywheel Bearing	96	2	M3 x 16mm Screw
43	1	Magnet	97	1	Pivot Axle
44	1	Flywheel Axle	98	8	M8 Jam Nut
45	2	Adjustment Knob	99	4	M8 x 65mm Button Screw
46	11	M8 Nylon Locknut	100	4	M8 Split Washer
47	2	Crank Screw	101	4	M8 x 45mm Button Screw
48	2	Hub Cover	102	2	Pin Collar
49	1	M6 x 25mm Bolt	103	1	Right Pedal Arm
50	4	M8 x 45mm Button Bolt	104	2	M8 Washer
51	4	M6 x 18mm Button Bolt	105	1	Water Bottle Holder
52	1	“C” Magnet Bracket	#	2	Hex Key
53	10	M8 Large Washer	#	1	Grease
54	1	“C” Magnet	#	1	User’s Manual

Note: “#” indicates a non-illustrated part. Specifications are subject to change without notice. **If a part is missing, call toll-free 1-888-533-1333.** See the back cover of this manual for information about replacement parts.

EXPLODED DRAWING A—Model No. 831.28643.0

R0806A

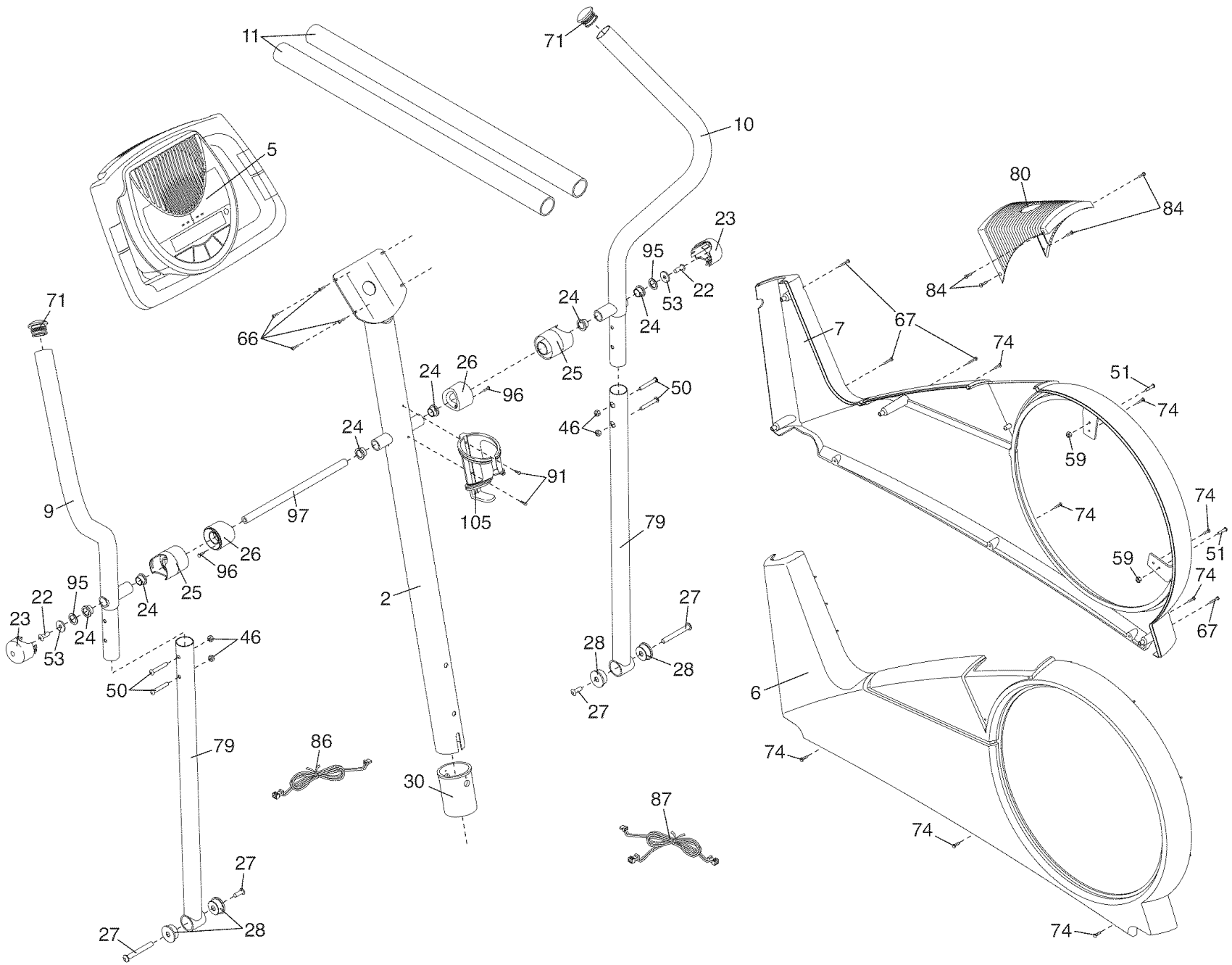

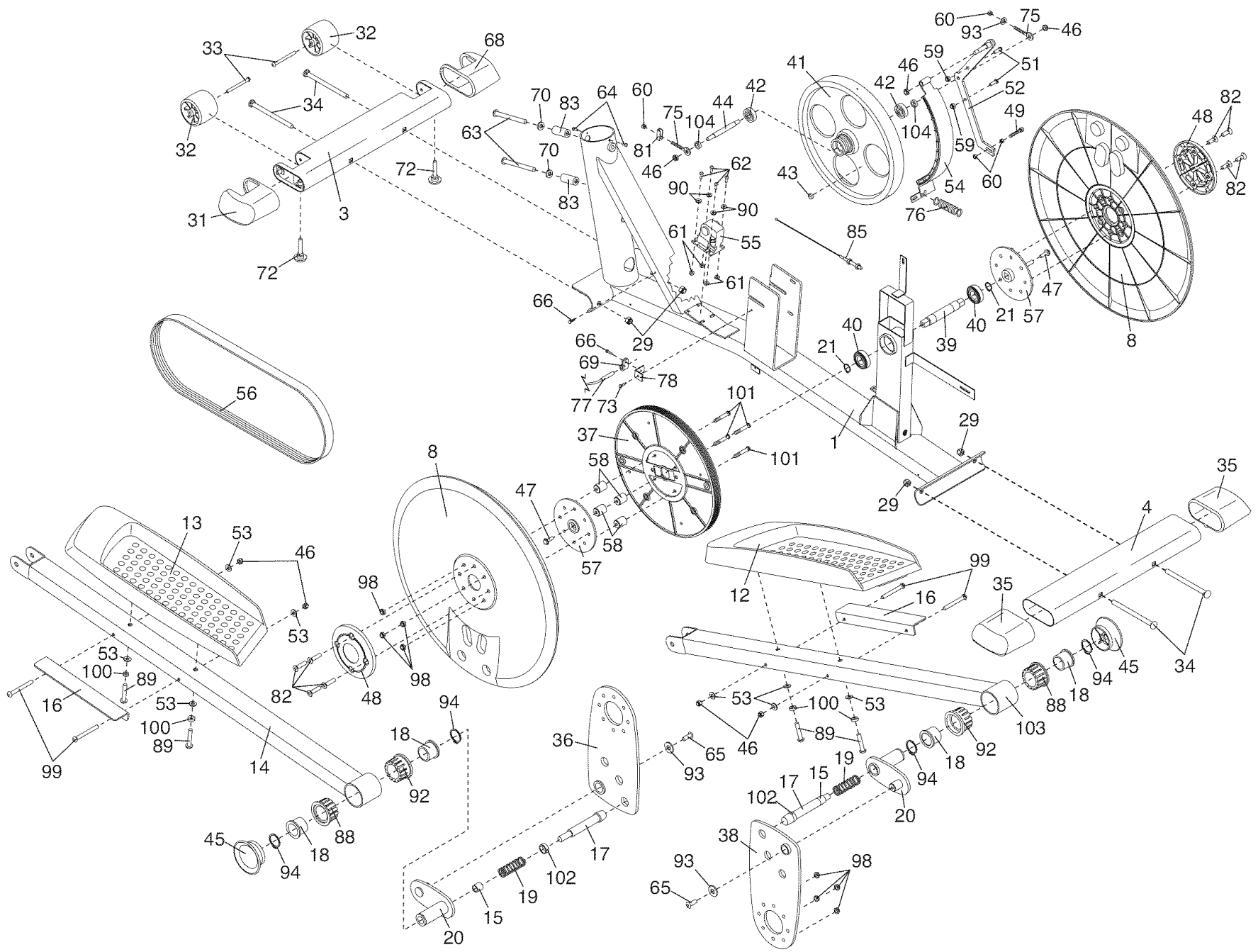

Get it fixed, at your home or ours!

Your Home

For repair—in **your home**—of **all** major brand appliances, lawn and garden equipment, or heating and cooling systems, **no matter who made it, no matter who sold it!**

For the replacement parts, accessories, and user's manuals that you need to do-it-yourself.

For Sears professional installation of home appliances and items like garage door openers and water heaters.

1-800-4-MY-HOME® (1-800-469-4663)

Call anytime, day or night (U.S.A. and Canada)

www.sears.com

www.sears.ca

Our Home

For repair of carry-in items like vacuums, lawn equipment, and electronics, call or go on-line for the location of your nearest **Sears Parts & Repair Center.**

1-800-488-1222 Call anytime, day or night (U.S.A. only)

www.sears.com

To purchase a protection agreement (U.S.A.) or maintenance agreement (Canada) on a product serviced by Sears:

1-800-827-6655 (U.S.A.)

1-800-361-6665 (Canada)

Para pedir servicio de reparación a domicilio, y para ordenar piezas:

1-888-SU-HOGAR® (1-888-784-6427)



® Registered Trademark / ™ Trademark / ™ Service Mark of Sears Brands, LLC
© Marca Registrada / ™ Marca de Fábrica / ™ Marca de Servicio de Sears Brands, LLC

90 DAY FULL WARRANTY

If this Sears Elliptical Exerciser fails due to a defect in material or workmanship within 90 days of the date of purchase, call 1-800-4-MY-HOME® (1-800-469-4663) to arrange for free repair (or replacement if repair proves impossible). The frame is warranted for 5 years.

This warranty does not apply when the Elliptical Exerciser is used commercially or for rental purposes.

This warranty gives you specific legal rights, and you may also have other rights which vary from state to state.

Sears, Roebuck and Co., Hoffman Estates, IL 60179