

*For Use With:
EF36 version P-A
IF36 version P-A*

TABLE OF CONTENTS

IMPORTANT SAFETY INSTRUCTIONS.....	1-2
ELECTRONIC CONTROL CENTER	3-4
REFRIGERATOR COMPARTMENT.....	5-6
FREEZER COMPARTMENT.....	6
ICE AND WATER.....	7
WATER FILTER	8
PERFORMANCE DATA	9
FOOD STORAGE TIPS	10-12
CARE AND CLEANING.....	13-16
OPERATING SOUNDS	17
BEFORE YOU CALL FOR SERVICE.....	18
WARRANTY & SERVICE.....	19-20



To Our Valued Customer:

Congratulations on your purchase of the very latest in Dacor products! Our unique combination of features, style and performance make us the life of the kitchen™, and a great addition to your home.

In order to familiarize yourself with the controls, functions and full potential of your new distinctive appliance, we suggest that you thoroughly read this Use & Care Manual, beginning with the **Important Instructions** Section.

All Dacor Appliances are designed and manufactured with quality and pride, while working within the framework of our Company Value. Should you ever experience a problem with your product, please first check the **Before You Call for Service** Section of this manual for guidance. It provides useful suggestions and remedies prior to calling for service.

Valuable customer input helps us to continuously improve our products and services, so please feel free to contact our Customer Service Team for assistance with any of your product support needs.

Dacor Customer Service
1440 Bridge Gate Drive
Diamond Bar, CA 91765

Telephone: (800) 793-0093
Fax: (626) 403-3130
Hours of Operation: Monday through Friday
6:00 A.M. to 5:00 P.M. Pacific Time
Web Site: www.dacor.com

Thank you for choosing Dacor for your home. We are a company built by families for families and we are dedicated to serving yours. We are confident that your new Dacor product will deliver a high level of performance and enjoyment for many years to come.

Sincerely,

Cheryl Crowe
Director, Customer Satisfaction

IMPORTANT SAFETY INSTRUCTIONS

Installer: Please leave this guide with this appliance.

Consumer: Please read and keep this Use & Care Manual for future reference. This guide provides proper use and maintenance information. **Keep this guide and the sales receipt and/or cancelled check in a safe place for future reference. Proof of original purchase date is needed for warranty service.**

If you have any questions, call:

Dacor[®] Customer Service
1-800-793-0093 (U.S.A. and Canada)
Monday — Friday 6:00 am to 5:00 pm Pacific Time
website: www.dacor.com

Have complete model and serial number identification of your refrigerator ready. These numbers are found on a serial plate, located on the right side of the refrigerator liner. Record these numbers below for easy access.

Model Number _____

Serial Number _____

Date of Purchase _____

For service and warranty information, see page 19-20.

In our continuing effort to improve the quality and performance of our appliances, it may be necessary to make changes to the appliance without revising this guide.

What You Need to Know About Safety Instructions

Warning and Important Safety Instructions appearing in this guide are not meant to cover all possible conditions and situations that may occur. Common sense, caution and care must be exercised when installing, maintaining or operating an appliance.

Always contact the manufacturer about problems or conditions you do not understand.

Recognize Safety Symbols, Words, Labels

⚠ DANGER

DANGER – Immediate hazards which **WILL** result in severe personal injury or death.

⚠ WARNING

WARNING – Hazards or unsafe practices which **COULD** result in severe personal injury or death.

⚠ CAUTION

CAUTION – Hazards or unsafe practices which **COULD** result in minor personal injury or property damage.

⚠ DANGER

To reduce risk of injury or death, follow basic precautions, including the following:

IMPORTANT: Child entrapment and suffocation are not problems of the past. Junked or abandoned refrigerators are still dangerous – even if they sit out for “just a few days.” If you are getting rid of your old refrigerator, please follow the instructions below to help prevent accidents.

Before you throw away your old refrigerator or freezer:

- Take off the doors.
- Leave the shelves in place so children may not easily climb inside.

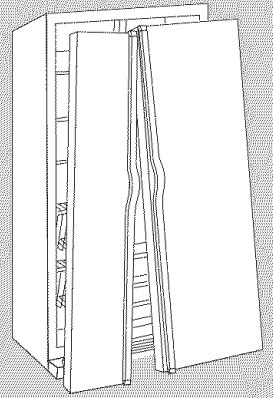

This appliance is equipped with a three-prong grounding plug for your protection against possible electrical shock hazards. It must be plugged into a grounded receptacle. Where a standard two-prong wall receptacle is encountered, it is the personal responsibility and obligation of the customer to have it replaced with a properly grounded three-prong wall receptacle. **Do not under any circumstances, cut or remove the third (ground) prong from the power cord.** Do not use an adapter plug. Do not use an extension cord. **Do not use a Ground Fault Circuit Interrupter.**

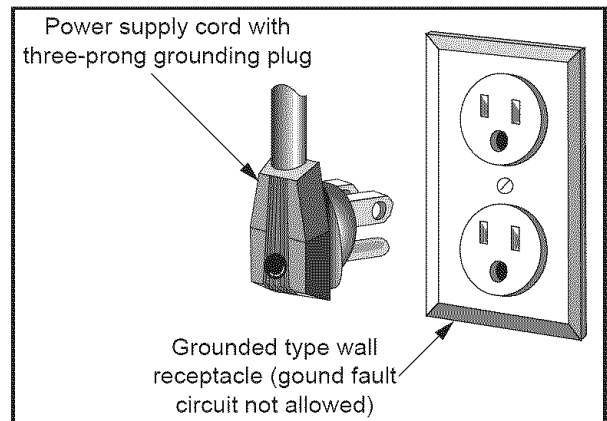

IMPORTANT SAFETY INSTRUCTIONS

⚠ WARNING

To reduce risk of fire, electric shock, serious injury or death when using your refrigerator, follow these basic precautions, including the following:

- 1 Read all instructions before using the refrigerator
- 2 Observe all local codes and ordinances
- 3 Be sure to follow grounding instructions
- 4 Check with a qualified electrician if you are not sure this appliance is properly grounded
- 5 Do not ground to a gas line
- 6 Do not ground to a cold-water pipe
- 7 Refrigerator is designed to operate on a dedicated 115 volt, 15 amp , 60 cycle line
- 8 Do not modify plug on power cord If plug does not fit electrical outlet, have proper outlet installed by a qualified electrician
- 9 Do not use a two-prong adapter, extension cord or power strip
- 10 Do not remove warning tag from power cord
- 11 Do not tamper with refrigerator controls
- 12 Do not service or replace any part of refrigerator unless specifically recommended in Use & Care Manual or published user-repair instructions Do not attempt service if instructions are not understood or if they are beyond personal skill level
- 13 Always disconnect refrigerator from electrical supply before attempting any service
- 14 Install refrigerator according to Installation Instructions All connections for water, electrical power and grounding must comply with local codes and be made by licensed personnel when required
- 15 Keep your refrigerator in good condition Bumping or dropping refrigerator can damage refrigerator or cause refrigerator to malfunction or leak If damage occurs, have refrigerator checked by qualified service technician
- 16 Replace worn power cords and/or loose plugs
- 17 Always read and follow manufacturer's storage and ideal environment instructions for items being stored in refrigerator
- 18 Your refrigerator should not be operated in the presence of explosive fumes
- 19 Children should not climb, hang or stand on any part of the refrigerator
- 20 Clean up spills or water leakage associated with water installation

SAVE AND KEEP THESE INSTRUCTIONS

ELECTRONIC CONTROL CENTER

The control center is located at the top front of the fresh food compartment.

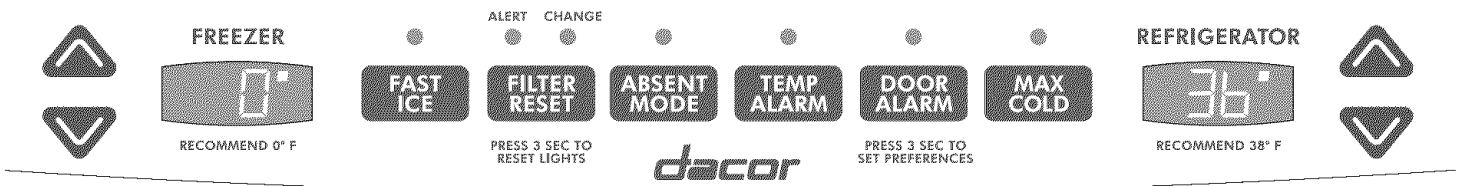

INITIAL TEMPERATURE SETTINGS

Temperatures are preset at 37° F (3° C) in the fresh food compartment and 0° F (-18° C) in the freezer compartment. The display will show the average compartment temperatures, based on several measurement points within the compartment.

Note:

Temperatures displayed may vary from set point due to door openings or during defrost. Thermometers placed in the refrigerator may record a temperature slightly above or below the displayed temperature. This is normal as the displayed temperature is an average.

TEMPERATURE ADJUSTMENTS

- Allow the temperature to stabilize for 24 hours after loading the refrigerator before making any temperature adjustments.
- The first touch of the up or down arrow shows the current temperature set point.
- Subsequent touches of the ▲ pad raise the temperature set point or the ▼ pad lowers the temperature set point.
- The display will show the new set point for approximately three seconds, then return to the actual temperature currently within that compartment.
- Limit temperature changes to one degree at a time. Allow the new temperatures to stabilize for 24 hours before making a new temperature adjustment.

FAST ICE

When activated, Fast Ice reduces the freezer temperature to the optimum setting for 24 hours in order to produce more ice.

Note:

When the Fast Ice feature is in operation, the ▼ and ▲ pads for the freezer control will not operate.

RESET FILTER

When a water filter has been installed in the refrigerator, the yellow **Alert** light will illuminate when 90 percent of the volume of water for which the filter is rated has passed through the filter OR 11 months have elapsed since the filter has been installed.

The red **Change** light will illuminate when the rated volume of water has passed through the filter OR 12 months have elapsed since the filter was installed. A new filter should be installed immediately when the **Change** light is illuminated.

After replacing the filter, press and hold the Reset Filter pad for three seconds. The **Alert** and **Change** lights will go off.

ABSENT MODE

The Absent Mode feature causes the freezer to defrost less frequently, conserving energy. The Absent Mode indicator light will illuminate when the feature is activated. To deactivate, press the Absent Mode pad again OR open either door. The indicator light will go out.

Notes:

- Door openings will not deactivate Absence Mode for approximately one hour after activation.
- If vacationing for more than a few days, see the Preparing for Absent section, page 16.

TEMP ALARM

The Temp Alarm system will alert you if the freezer or fresh food temperatures exceed normal operating temperatures due to a power outage or other event. When activated, the Temp Alarm light will illuminate.

If the freezer or fresh food temperatures have exceeded these limits, the display will alternately show the current compartment temperatures and the highest compartment temperatures reached when the power was out. An audible alarm will sound repeatedly.

Press the Temp Alarm pad once to stop the audible alarm. The Temp Alarm light will continue to flash and the temperatures will alternate until the temperatures have stabilized.

To turn off Temp Alarm, press and hold the Temp Alarm pad for three seconds. The indicator light will go off.

DOOR ALARM

The Door Alarm will alert you when one of the doors has been left open for five continuous minutes. When this happens, an audible alarm will sound every few seconds until the door is closed OR press the Door Alarm pad to deactivate the feature.

ELECTRONIC CONTROL CENTER

MAX COOL



When activated, Max Cool causes the fresh food and freezer temperatures to drop to the minimum settings on the control. This cools down the refrigerator and freezer after extended door openings or when loading the refrigerator or freezer with warm food.

Note:

When the Max Cool feature is in operation, the ▼ and ▲ pads for the refrigerator and freezer controls will not operate.

To activate, press the Max Cool pad. Max Cool will deactivate automatically after 12 hours, OR press the Max Cool pad to deactivate the feature.

USER PREFERENCES

Access the User Preferences menu to:

- Change the temperature display from °F to °C
- Enable or disable audible alarms.
- Activate the Sabbath Mode

To access the User Preferences menu, press and hold the Door Alarm pad for three seconds. When in the User Preferences mode, a short title for the feature will appear in the freezer temperature display and the feature status will appear in the fresh food display.

1. Use the freezer up and down control to scroll through the features.
2. When the desired feature is displayed, use the fresh food ▼ and ▲ control to change the status.
3. When changes are complete, press the Door Alarm pad for three seconds OR close the fresh food door.

TEMPERATURE DISPLAY (F_C)

Change the display to show temperatures in degrees Fahrenheit or degrees Celsius.

ALARM (AL)

When the Alarm mode is OFF, all audible alarms will be disabled until the feature is turned on.

SABBATH MODE (SAB)

When the Sabbath Mode is ON, all control lights and the night light will be disabled until the feature is turned OFF. This feature does not disable the interior lights. Press any pad to restore the control lights.

WARM CABINET SURFACES

At times, the front of the refrigerator cabinet may be warm to the touch. This is a normal occurrence that helps prevent moisture from condensing on the cabinet. This condition will be more noticeable when the refrigerator is first started, during hot weather and after excessive or lengthy door openings.

REFRIGERATOR COMPARTMENT

SHELVES

CAUTION

To avoid personal injury or property damage, observe the following:

- Never attempt to adjust a shelf that is loaded with food.
- Confirm shelf is secure before placing items on shelf.
- Handle tempered glass shelves carefully. Shelves may break suddenly if nicked, scratched, or exposed to sudden temperature change.

Your refrigerator has Spill-proof Glass Shelves. The Spill-proof shelves have a spill retainer edge which allows for easier clean up and are equipped with a slide out feature. To slide out, grasp the front of the shelf and pull forward. Push in the shelf to return to the original position.

To Remove a Shelf:

- Slightly tilt up the front and lift up the rear of the shelf, then pull the shelf straight out.

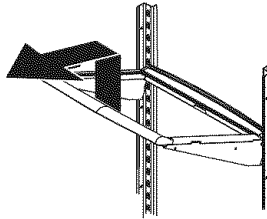

To Lock the Shelf Into Another Position:

- Tilt up the front edge of the shelf.
- Insert the hook into the desired frame openings and let the shelf settle into place.
- Be sure the shelf is securely locked at the rear.

DOOR STORAGE

Dairy Center

The Dairy Center provides convenient door storage for spreadable items such as butter and margarine. This compartment can be moved to different locations to accommodate storage needs. To use the dairy center, raise the cover.

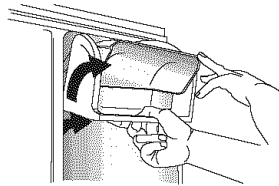

To Remove:

- Raise the cover, pull upward and tilt out.

To Install:

- Slide the Dairy Center in and down until firmly seated in the door liner.

Door Buckets

Door Buckets can be moved to meet storage needs.

To Remove:

- Slide bucket up and pull straight out.

To Install:

- Slide bucket in and down until firmly seated in the door liner.

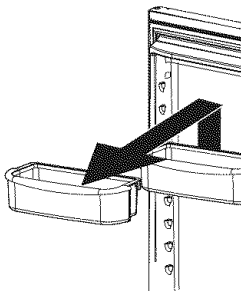

Crisper Drawers

The Crisper Drawers provide a higher humidity environment for fresh fruit and vegetable storage.

Controls

The Crisper Controls regulate the amount of humidity in the crisper drawer. Slide the control toward the Fruit setting for produce with outer skins. Slide the control toward the Vegetables setting for leafy produce.

Vegetables

Fruit

To Remove:

- Pull drawer out to full extension. Tilt up front of drawer and pull straight out.

To Install:

- Insert drawer into frame rails and push back into place.

Note:

For best results, keep the crisper drawers tightly closed.

DELI DRAWER

The Deli Drawer is a full-width drawer with adjustable temperature control. This drawer can be used for large party trays, deli items, beverages or miscellaneous items. There is a divider to organize the drawer into sections if desired.

There is a temperature control which adjusts the amount of cold air allowed into the Deli Drawer. The control is located on the right of the drawer, under the lid.

Set the control to **cold** to provide a normal refrigerator temperature. Set the drawer on the **coldest MAX COLD** setting when a temperature colder than the main refrigerator compartment is desired. Use the coldest setting when storing meats.

Notes:

- Cold air directed to the Deli Drawer can decrease refrigerator temperature. Refrigerator control may need to be adjusted.
- Do not place leafy vegetables in the Deli Drawer. Colder temperatures could damage leafy produce.

To Remove:

- Lift lid. Pull drawer out to full extension. Tilt the drawer front up and pull straight out.

To Install:

- Push metal glide rails to the back of the refrigerator. Place drawer onto rails and slide drawer back until it falls into place.

To Remove Divider:

- Pull drawer completely out and raise the front of the divider to unhook it from the rear wall of the pantry and lift it out.

To Install Divider:

- Hook back of divider over rear wall of pantry and lower into place.

REFRIGERATOR COMPARTMENT

ACCESSORIES

Wine Trivet/Can Rack

The Wine Trivet/Can Rack accessory fits in the Deli Drawer or on a shelf.

Bottles or cans can be laid crosswise, or a single bottle may be laid in the center depression.

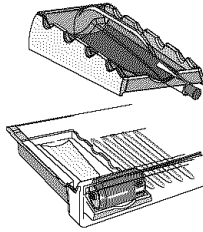

Deli Drawer Tray

The Deli Drawer tray allows for a removable tray within the full-width storage drawer.

FREEZER COMPARTMENT

UPPER WIRE BASKET

⚠ DANGER

To prevent accidental child entrapment or suffocation risk, do not remove the divider in the top freezer basket

To Remove:

- Turn off ice maker by raising the ice maker arm (see page 7).
- Pull upper basket out to full extension and lift out to remove.

To Install:

- Slide upper basket into freezer. Make sure that rear of basket hooks behind rail catch.

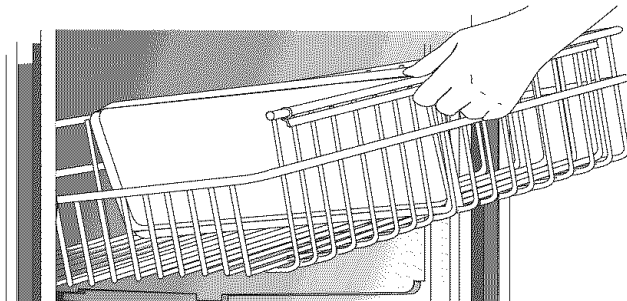

ACCESSORIES

Ice Bin

The ice bin provides storage for ice.

Lower Basket Divider

The lower basket divider allows the option to organize the basket area into sections.

To remove and replace divider:

- To remove, pull divider straight up.
- To install, hook top corners of divider over top horizontal basket rungs.

ICE AND WATER

AUTOMATIC ICE MAKER

Connect the ice maker to the water supply as instructed in the installation instructions. **Proper water flow and a level refrigerator are essential for optimal ice maker performance.**

Operating Instructions

- Confirm ice bin is in place and ice maker arm is down.
- After freezer section reaches between 0° to 2° F (-18° to -17° C), ice maker fills with water and begins operating. You will have a complete harvest of ice approximately every three hours.
- Allow approximately 24 hours after installation to receive first harvest of ice.
- Discard ice created within first 12 hours of operation to assure system is flushed of impurities.
- Stop ice production by raising ice maker arm until click is heard.
- Ice maker will remain in the off position until arm is pushed down.
- The first one or two batches will probably contain undersized and irregular cubes because of air in the supply line.
- When the ice cubes are ejected it is normal for several cubes to be joined together at the ends. They can easily be broken apart. The ice maker will continue to make ice until the supply of ice cubes raises the ice maker arm, shutting the ice maker off.
- Certain sounds may accompany the various cycles of the ice maker. The motor may have a slight hum, the cubes will rattle as they fall into an empty storage pan and the water valve may click or "buzz" occasionally.
- If the ice is not used frequently, the ice cubes will become cloudy, shrink, stick together and taste stale. Empty the ice storage bin periodically and wash it in lukewarm water. Be sure to dry the bin thoroughly before replacing it.
- Beverages and foods should not be placed in the ice storage bin for quick chilling. These items can block the ice maker arm, causing the ice maker to malfunction.
- Turn off (arm up) the ice maker when the water supply is to be shut off for several hours.

To Remove the Ice Bin:

- Pull it forward, away from the ice maker. To avoid the ice maker dumping ice while the bin is removed, turn the ice maker off by raising the icemaker arm.

To Install the Ice Bin:

- Reverse the above procedure. Turn the ice maker on by lowering the ice maker arm.

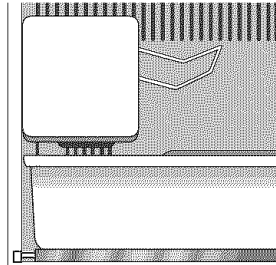

CAUTION

To avoid personal injury or property damage, observe the following:

- Do not place fingers or hands on the automatic ice making mechanism while the refrigerator is plugged in. This will help protect you from possible injury. It will also prevent interference with moving parts of the ejector mechanism and the heating element that releases the cubes.
- Under certain rare circumstances, ice cubes may be discolored, usually appearing with a green-bluish hue. The cause of this unusual discoloration can be a combination of factors such as certain characteristics of local waters, household plumbing and the accumulation of copper salts in an inactive water supply line which feeds the ice maker. Continued consumption of such discolored ice cubes may be injurious to health. If such discoloration is observed, discard the ice cubes and contact your dealer to purchase and install a water line filter.
- Water damage due to improper water connection may cause mold/mildew growth.
- Clean up water and ice spills to avoid personal injury and to prevent mold/mildew growth.

Water Dispenser

The Water Dispenser is located on the left side wall of the fresh food section. This design is for cold water dispensing only.

To Dispense Water:

- Hold container under spout and press dispenser pad.

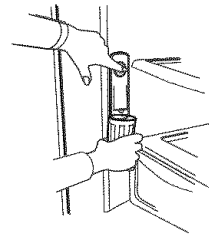

WATER FILTER

REMOVAL AND INSTALLATION

⚠ WARNING

To avoid serious illness or death:

- Do not use refrigerator where water is unsafe or of unknown quality without adequate disinfection before or after use of filter.
- Systems certified for cyst reduction may be used on disinfected waters that may contain filterable cysts.

⚠ CAUTION

After installing a new water filter, always dispense water for two minutes before removing the filter for any reason. Air trapped in system may cause water and cartridge to eject. Use caution when removing.

- The bypass cap does not filter water. Be sure to have replacement cartridge available when filter change is required.
- If water filtration system has been allowed to freeze, replace filter cartridge.
- If system has not been used for several months, or water has an unpleasant taste or odor, flush system by dispensing water for two to three minutes. If unpleasant taste or odor persists, change filter cartridge.

Initial Installation

The water filter is located in the upper right hand corner of the fresh food compartment.

1. Remove blue bypass cap and retain for later use.
2. Remove sealing label from end of filter and insert into filter head.
3. Rotate gently clockwise until filter stops. Snap filter cover closed.

4. Reduce water spurts by flushing air from system. Run water continuously for two minutes through dispenser until water runs steady. During initial use, allow about a one- to two-minute delay in water dispersal to allow internal water tank to fill.

- Additional flushing may be required in some households where water is of poor quality.

Replacing Water Filter

IMPORTANT: Air trapped in system may cause water and cartridge to eject. Always dispense water for two minutes before removing the filter for any reason. Use caution when removing.

1. Turn filter counterclockwise until it releases from filter head.
2. Drain water from filter into sink, and dispose of filter in normal household trash.
3. Wipe up excess water in filter cover and continue with Initial Installation, steps 2 through 4.

The filter should be changed at least every 12 months.

Important: Condition of water and amount used determines life span of water filter cartridge. If water use is high, or if water is of poor quality, replacement may need to take place more often.

To replacement filter cartridges or for service, contact your local dealer or Dacor Customer Service, 1-800-793-0093. (U.S.A. and Canada)

The dispenser feature may be used without a water filter cartridge. If you choose this option, replace filter with blue bypass cap.

State of California
Department of Health Services
Water Treatment Device
Certificate Number
03 - 1583

Date Issued: September 16, 2003
Date Revised: April 22, 2004

<u>Treatment Method/Technology</u>	<u>Microbiological Claims</u>
UF/RO/DA/XX/TS 447806-100 47010311-100	UF/RO/DA/XX 447806 47010311
<u>Manufacturer:</u> Dacor, Inc.	
The water treatment device(s) listed on this certificate have met the testing requirements pursuant to Section 104630 of the Health and Safety Code for the following health related contaminants:	
<u>Microbiological Contaminants and Toxins</u>	<u>Chemically-Related Contaminants</u>
Cysts Turbidity	Aluminum Lead Mercury
<u>Organic Compounds</u>	
Atrazine Endrin Dieldrin Carbofenthoate p-chlorophenoate Toxaphene	
<u>Rated Service Capacity:</u> 100 gal	<u>Rated Service Flow:</u> 0.78 gpm

Conditions of Certification:

Do not use where water is microbiologically unsafe or with water of unknown quality, except that systems certified for cyst reduction may be used on disinfected waters that may contain filterable cysts.

PERFORMANCE DATA

Standard No. 42: Aesthetic Effects								
Parameter	USEPA MCL	Influent Challenge Concentration	Influent Average	Effluent		% Reduction		Min. Required Reduction
				Average	Maximum	Average	Minimum	
Chlorine	-	2.0 mg/L ± 10%	1.88 mg/L	<0.05136364 mg/L	0.06 mg/L	>97.26	96.84	50%
Taste and Odor	-	-	-	-	-	-	-	-
Particulate**	-	at least 10,000 particles/ml	5,700,000 #/ml	30,583 #/ml	69,000 #/ml	99.52	98.94	85%

Standard No. 53: Health Effects								
Parameter	USEPA MCL	Influent Challenge Concentration	Influent Average	Effluent		% Reduction		Min. Required Reduction
				Average	Maximum	Average	Minimum	
Turbidity	1 NTU**	11 ± 1 NTU***	10.7 NTU	0.31 NTU	.049 NTU	97.09	95.20	0.5 NTU
Cysts	99.5% Reduction	Minimum 50,000/L	166,500 #/L	<1 #/L	<1 #/L	>99.99	>99.99	>99.99%
Asbestos	99% Reduction	10 ⁷ 10 ⁶ fibers/L; fibers > micrometers in length	155 MF/L	<1 MF/L	<1 MF/L	>99.99	>99.99	99%
Lead at pH 6.5	0.015 mg/L	0.15 mg/L +10%	0.153 mg/L	<.001 mg/L	<.001 mg/L	>99.35	>99.29	0.10 mg/L
Lead at pH 8.5	0.015 mg/L	0.15 mg/L +10%	0.150 mg/L	<.001 mg/L	<.001 mg/L	>99.33	>99.29	0.10 mg/L
Mercury at pH 6.5	0.002 mg/L	.006 mg/L ± 10%	0.006 mg/L	0.0003 mg/L	0.0005 mg/L	95.70	90.91	0.002 mg/L
Mercury at pH 8.5	0.002 mg/L	.006 mg/L ± 10%	0.006 mg/L	0.0008 mg/L	0.0015 mg/L	86.22	75.93	0.002 mg/L
Atrazine	0.003 mg/L	0.009 mg/L + 10%	0.009 mg/L	<0.002 mg/L	0.002 mg/L	76.99	75.31	0.003 mg/L
Benzene	0.005 mg/L	0.015 mg/L ± 10%	0.014 mg/L	0.0006 mg/L	0.0011 mg/L	95.71	92.14	0.005 mg/L
Carbofuran	0.04 mg/L	0.08 mg/L ± 10%	0.081 mg/L	<0.001 mg/L	<0.001 mg/L	98.74	98.46	0.04 mg/L
p-Dichlorobenzene	0.075 mg/L	.225 mg/L ± 10%	0.208 mg/L	<0.0005 mg/L	<0.0005 mg/L	99.76	99.74	0.075 mg/L
Lindane	0.0002 mg/L	0.002 mg/L ± 10%	0.002 mg/L	0.000 mg/L	<0.0001 mg/L	98.72	96.50	0.0002 mg/L
Toxaphene	0.003 mg/L	0.015 ± 10%	0.015 mg/L	<0.001 mg/L	<0.001 mg/L	92.97	91.67	0.003 mg/L

* Tested using a flow rate of 0.78 gpm; pressure of 60 psig; pH of 7.5 + 0.5; temp. of 68° + 5°F (20° + 3°C)
 ** Measurement in Particles/ml. Particles used were 0.5 - 1 microns
 *** NTU - Nephelometric Turbidity Units

SPECIFICATIONS

Rated Flow: .78 gpm (2.9 L/min)
 Min. Op.Temp: 33° F (.6° C)
 Max. Op.Temp: 100° F (38° C)
 Min. Op. Press: 35 psi (241 kPA)
 Max. Op. Press: 120 psi (827 kPA)



System tested and certified by NSF International against NSF/ANSI Std 42 for the reduction of Chlorine Taste and Odor, Particulate Class I and against NSF/ANSI 53 for the reduction of Cysts, Turbidity, Asbestos, Mercury, Lead, Benzene, p-Dichlorobenzene, Carbofuran

General Use Conditions

Read this Performance Data Sheet and compare the capabilities of this unit with your actual water treatment needs.

DO NOT use this product where water is microbiologically unsafe or of unknown quality without adequate disinfection before or after the system. System certified for cyst reduction may be used on disinfected water that may contain filterable cysts.

USE ONLY WITH COLD WATER SUPPLY. CHECK FOR COMPLIANCE WITH THE STATE AND LOCAL LAWS AND REGULATIONS.

The AquaClean™ retractable water filtration system uses an AFF3 replacement cartridge. Timely replacement of filter cartridge is essential for performance satisfaction from this filtration system. Please refer to the applicable section of your Use and Care Guide for general operation, maintenance requirements and troubleshooting.

This system has been tested according to ANSI/NSF 42 and 53 for reduction of the substances listed above. The concentration of the indicated substances in water entering the system was reduced to a concentration less than or equal to the permissible limit for water leaving the system, as specified in ANSI/NSF 42 and 53.

FOOD STORAGE TIPS

FRESH FOOD STORAGE

- The fresh food compartment of a refrigerator should be kept between 34°-40° F (1°-4° C) with an optimum temperature of 37° F (3° C). To check the temperature, place an appliance thermometer in a glass of water and place in the center of the refrigerator. Check after 24 hours. If the temperature is above 40° F (4° C) adjust the controls as explained on page 3.
- Avoid overcrowding the refrigerator shelves. This reduces the circulation of air around the food and results in uneven cooling.

Fruits and Vegetables

- Storage in the crisper drawers traps humidity to help preserve the fruit and vegetable quality for longer time periods (see page 5).
- Sort fruits and vegetables before storage and use bruised or soft items first. Discard those showing signs of decay.
- Always wrap odorous foods such as onions and cabbage so the odor does not transfer to other foods.
- While vegetables need a certain amount of humidity to remain fresh, too much humidity can shorten storage times (especially leafy vegetables). Drain vegetables well before storing.
- Wait to wash fresh produce until right before use.

Meat and Cheese

- Raw meat and poultry should be wrapped securely so leakage and contamination of other foods or surfaces does not occur.
- Occasionally mold will develop on the surface of hard cheeses (Swiss, Cheddar, Parmesan). Cut off at least an inch around and below the moldy area. Keep your knife or instrument out of the mold itself. Do not try to save individual cheese slices, soft cheese, cottage cheese, cream, sour cream or yogurt when mold appears.

Dairy Food

- Most dairy foods such as milk, yogurt, sour cream and cottage cheese have freshness dates on their cartons for appropriate length of storage. Store these foods in the original carton and refrigerate immediately after purchasing and after each use.

FROZEN FOOD STORAGE

- The freezer compartment of a refrigerator should be kept at approximately 0° F (-18° C). To check the temperature, place an appliance thermometer between the frozen packages and check after 24 hours. If the temperature is above 0° F (-18° C), adjust the control as described on pages 3.
- A freezer operates more efficiently when it is at least two-thirds full.

Packaging Foods for Freezing

- To minimize dehydration and quality deterioration use aluminum foil, freezer wrap, freezer bags or airtight containers. Force as much air out of the packages as possible and be sure they are tightly sealed. Trapped air can cause the food to dry out, change color and develop an off-flavor (freezer burn).
- Overwrap fresh meats and poultry with suitable freezer wrap prior to freezing.
- Do not refreeze meat that has completely thawed.

Loading the Freezer

- Avoid adding too much warm food to the freezer at one time. This overloads the freezer, slows the rate of freezing and can raise the temperature of frozen foods.
- Leave space between the packages so cold air can circulate freely, allowing food to freeze as quickly as possible.
- Avoid storing hard-to-freeze foods such as ice cream and orange juice on the freezer door shelves. These foods are best stored in the freezer interior where the temperature varies less with door openings.

Refer to the Food Storage Chart on pages 11-12 for approximate storage times.

FOOD STORAGE TIPS

Food Storage Chart

Storage times are approximate and may vary depending on type of packaging, storage temperature, and the quality of the food when purchased.

FOODS	REFRIGERATOR	FREEZER	STORAGE TIPS
DAIRY PRODUCTS			
Butter	1 month	6 to 9 months	Wrap tightly or cover.
Milk and cream	1 week	Not recommended	Check carton date. Close tightly. Don't return unused portions to original container. Don't freeze cream unless whipped.
Cream cheese, cheese spread and cheese food	1 to 2 weeks	Not recommended	Wrap tightly.
Cottage cheese	3 to 5 days	Not recommended	Store in original carton. Check carton date.
Sour cream	10 days	Not recommended	Store in original carton. Check carton date.
Hard cheese (Swiss, Cheddar and Parmesan)	1 to 2 months	4 to 6 months May become crumbly	Wrap tightly. Cut off any mold.
EGGS			
Eggs in the shell	3 weeks	Not recommended	Refrigerate small ends down.
Leftover yolks or whites	2 to 4 days	9 to 12 months	For each cup of yolks to be frozen, add 1 tsp. sugar for use in sweet, or 1 tsp. salt for non-sweet dishes.
FRUITS			
Apples	1 month	8 months (cooked)	May also store unripe or hard apples at 60° to 70° F (16° to 21° C).
Bananas	2 to 4 days	6 months (whole/peeled)	Ripen at room temperature before refrigerating. Note: Bananas will darken when refrigerated.
Pears, plums, avocados	3 to 4 days	Not recommended	Ripen at room temperature before refrigerating. Note: Avocados will darken when refrigerated.
Berries, cherries, apricots	2 to 3 days	6 months	Ripen at room temperature before refrigerating.
Grapes	3 to 5 days	1 month (whole)	Ripen at room temperature before refrigerating.
Citrus fruits	1 to 2 weeks	Not recommended	May also store at 60° to 70° F (16° to 21° C). If refrigerated, store uncovered.
Pineapples, cut	2 to 3 days	6 to 12 months	Will not ripen after purchase. Use quickly.
VEGETABLES			
Asparagus	1 to 2 days	8 to 10 months	Do not wash before refrigerating. Store in crisper.
Brussels sprouts, broccoli, cauliflower, green peas, lima beans, onions, peppers	3 to 5 days	8 to 10 months	Wrap odorous foods. Leave peas in pods.
Cabbage, celery	1 to 2 weeks	Not recommended	Wrap odorous foods and refrigerate in crisper.
Carrots, parsnips, beets and turnips	7 to 10 days	8 to 10 months	Remove tops. Wrap odorous foods and refrigerate in crisper.
Lettuce	7 to 10 days	Not recommended	
POULTRY and FISH			
Chicken and Turkey, whole	1 to 2 days	12 months	Keep in original packaging for refrigeration. Place in the Deli Drawer on coldest setting. When freezing longer than two weeks, overwrap with freezer wrap.
Chicken and Turkey, pieces	1 to 2 days	9 months	
Fish	1 to 2 days	2 to 6 months	

continued...

FOOD STORAGE TIPS

FOODS	REFRIGERATOR	FREEZER	STORAGE TIPS
MEATS			
Bacon	7 days	1 month	
Beef or lamb, ground	1 to 2 days	3 to 4 months	Fresh meats can be kept in original packaging for refrigeration.
Beef or lamb, roast and steak	3 to 5 days	6 to 9 months	Place in the Deli Drawer on coldest setting. When freezing longer than two weeks, overwrap with freezer wrap
Ham, full cooked, whole	7 days	1 to 2 months	
half	5 days	1 to 2 months	
slices	3 days	1 to 2 months	
Luncheon meat	3 to 5 days	1 to 2 months	Unopened, vacuum-packed luncheon meat may be kept up to two weeks in the Deli Drawer on coldest setting.
Pork, roasts	3 to 5 days	4 to 6 months	
Pork, chops	3 to 5 days	4 months	
Sausage, ground	1 to 2 days	1 to 2 months	
Sausage, chops	7 days	1 to 2 months	
Veal	3 to 5 days	4 to 6 months	
Frankfurters	7 days	1 month	Processed meats should be tightly wrapped and stored in the Deli Drawer on coldest setting.

Sources: United States Department of Agriculture; Food Marketing Institute; Cooperative Extension Service, Iowa State University

CARE AND CLEANING

⚠ WARNING

To avoid electrical shock which can cause severe personal injury or death, disconnect power to refrigerator before cleaning. After cleaning, reconnect power.

⚠ CAUTION

To avoid personal injury or property damage, observe the following:

- Read and follow manufacturer's directions for all cleaning products.
- **Do not place buckets, shelves or accessories in dishwasher. Cracking or warping of accessories may result.**

Refrigerator Cleaning Chart

PART	DO NOT USE	DO
Cabinet Interior	Abrasive or harsh cleaners Ammonia Chlorine bleach Concentrated detergents or solvents Metal or plastic-textured scouring pads	Use 4 tablespoons of baking soda dissolved in 1 quart (1 liter) warm soapy water. Rinse surfaces with clean warm water and dry immediately to avoid water spots.
Stainless Steel Doors and Exterior IMPORTANT: <i>Damage to stainless steel finish due to improper use of cleaning products or non-recommended products is not covered under this product's warranty.</i>	Abrasive or harsh cleaners Ammonia Chlorine bleach Concentrated detergents or solvents Metal or plastic-textured scouring pads Vinegar-based products Citrus-based cleaners	Use warm, soapy water and a soft, clean cloth or sponge. Rinse surfaces with clean warm water and dry immediately to avoid water spots.
Door Gaskets	Metal or plastic-textured scouring pads	Use warm, soapy water and a soft, clean cloth or sponge.
Condenser Coil <i>Remove base grille to access.</i>	Anything other than a vacuum cleaner	Use a vacuum cleaner hose nozzle.
Condenser Fan Outlet Grille <i>See back of refrigerator.</i>		Use a vacuum cleaner hose nozzle with brush attachment.
Accessories <i>Shelves, buckets, drawers, etc.</i>	A dishwasher	Follow removal and installation instructions from appropriate feature section. Allow items to adjust to room temperature. Dilute mild detergent and use a soft clean cloth or sponge for cleaning. Use a plastic bristle brush to get into crevices. Rinse surfaces with clean warm water. Dry glass and clear items immediately to avoid spots.

CARE AND CLEANING

REMOVING ODORS FROM REFRIGERATOR

⚠ WARNING

To avoid electrical shock which can cause severe personal injury or death, disconnect power to refrigerator before cleaning. After cleaning, reconnect power.

1. Remove all food and turn the refrigerator OFF.
2. Disconnect power to the refrigerator.
3. Clean the walls, floor, ceiling of cabinet interior, drawers, shelves and gaskets according to the instructions on page 13.
4. Dilute mild detergent and brush solution into crevices using a plastic bristle brush. Let stand for 5 minutes. Rinse surfaces with warm water. Dry surfaces with a soft, clean cloth.
5. Wash and dry all bottles, containers and jars. Discard spoiled or expired items.
6. Wrap or store odor-causing foods in tightly sealed containers to prevent recurring odors.
7. Reconnect power to refrigerator and return food to refrigerator.
8. Allow the refrigerator to cool.
9. After 24 hours, check if odor has been eliminated.

If odor is still present:

1. Remove drawers and place on top shelf of refrigerator.
2. Pack refrigerator and freezer sections – including doors – with crumpled sheets of black and white newspaper.
3. Place charcoal briquettes randomly on crumpled newspaper in both freezer and refrigerator compartments.
4. Close doors and let stand 24 to 48 hours.

ENERGY SAVING TIPS

- Avoid overcrowding refrigerator shelves. Overcrowding reduces air circulation around food and causes refrigerator to run longer.
- Avoid adding too much warm food to refrigerator at one time. This overloads compartments and slows rate of cooling.
- Do not use aluminum foil, wax paper, or paper toweling as shelf liners. This decreases air flow and causes refrigerator to run less efficiently.
- A freezer that is two-thirds full runs most efficiently.
- Locate refrigerator in coolest part of room. Avoid areas of direct sunlight, or near heating ducts, registers or other heat producing appliances. If this is not possible, isolate exterior by using a section of cabinet or an added layer of insulation.

- Clean door gaskets every three months according to cleaning instructions. This will assure that the door seals properly and refrigerator runs efficiently.
- Take time to organize items in refrigerator to reduce time that door is open.
- Be sure your doors are closing securely by leveling refrigerator as instructed in your installation instructions.
- Clean condenser coils as indicated in the cleaning instructions every three months. This will increase energy efficiency and cooling performance.

CARE AND CLEANING

REPLACING LIGHT BULBS

⚠ WARNING

To avoid electrical shock which can cause severe personal injury or death, disconnect power to refrigerator before replacing light bulb. After replacing light bulb, reconnect power.

⚠ CAUTION

To avoid personal injury or property damage, observe the following:

- Allow light bulb to cool.
- Wear gloves when replacing light bulb.

FRESH FOOD SECTION

1. Slide clear light shield toward back of compartment to release from light assembly.
2. Remove light bulbs.
3. Replace with appliance bulbs **no greater than 40 watts**.
4. Replace light bulb cover by inserting tabs on light shield into liner holes on each side of light assembly. Slide shield toward front of refrigerator until it locks into place. Do not force shield beyond locking point. Doing so may damage light shield.

FREEZER SECTION

1. Reach behind the light cover.
2. With firm pressure, press forward on the notches at the back of the cover and pull down. The cover will open from the back.
3. Remove the cover.
4. Remove light bulb.
5. Replace bulb with appliance bulb **no greater than 40 watts**.
6. Insert front tabs of light cover into slots in freezer liner and snap rear portion over light assembly until rear tab engages.

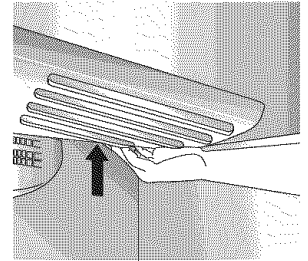
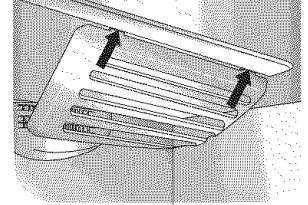
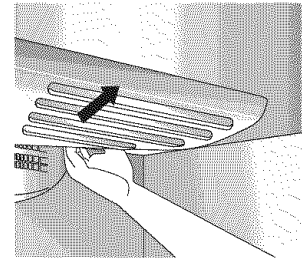

CARE AND CLEANING

PREPARING FOR VACATION/ABSENCE

⚠ CAUTION

If your refrigerator has a dispenser and there is any possibility that the temperature can drop below freezing where the refrigerator is located, the water supply system (including the water tank and the water valve) must be drained by a qualified servicer.

For short vacations or absences (three months or less):

1. Remove all perishables.
2. If no one will be checking in on the refrigerator during your absence, remove all frozen items also.
3. If your refrigerator has an automatic ice maker:
 - Shut off the water supply to the ice maker at least one day ahead of time.
 - After the last load of ice drops, raise the wire shut off arm to the OFF position.
 - Empty the ice bin.
4. If the room temperature will drop below 55° F (13° C), follow the instructions for longer absences.

For long vacations, absences (more than three months) OR if the room temperature will drop below 55° F (13° C):

1. Remove food.
2. If your refrigerator has an automatic ice maker:
 - Shut off the water supply to the ice maker at least one day ahead of time.
 - After the last load of ice drops, raise the wire shut off arm to the OFF position.
 - Empty the ice bin.
3. If your refrigerator has a dispenser system with water filter, remove the water filter cartridge and install the filter bypass. Dispose of the used cartridge.
4. Turn the freezer control to **OFF**.
5. Unplug the refrigerator.
6. Thoroughly clean the interior of both compartments with a baking soda solution and a clean soft cloth (four tablespoons of baking soda in one quart of warm water).
7. Dry thoroughly.
8. Leave the doors open to prevent the formation of mold and mildew.

UPON YOUR RETURN

After a short vacation or absence:

For models with automatic ice makers or dispensers:

- Reconnect the water supply and turn on supply valve.
- Monitor water connection for 24 hours and correct leaks if necessary.
- Run 10-15 glasses of water from the dispenser to flush out the system.
- Restart the ice maker by lowering the ice maker arm.
- Discard at least the first three ice harvests.

After a long vacation or absence:

- Reconnect the water supply and turn on supply valve.
- Plug the refrigerator back in and reset controls (see page 3).
- Monitor water connection for 24 hours and correct leaks, if necessary.

For dispenser models, run water through the dispenser for at least three minutes with the filter bypass in place, then install water filter (see page 8).

- After installing the water filter, run water through the dispenser continuously for at least two minutes, or until water runs steady. Initially you may notice a one to two minute delay in water dispersal as the internal tank fills.
- Restart the ice maker by lowering the ice maker arm.
- Discard ice produced within the first 12 hours (at least the first three harvests).

PREPARING TO MOVE

- Follow the above instructions for long vacations/absences, through step 7.
- Secure all loose items such as shelves and drawers by taping them securely in place to prevent damage.
- Tape the doors shut.
- Use an appliance dolly when moving the refrigerator. Always truck the refrigerator from its side or back - never from its front.
- Be sure the refrigerator stays in an upright position during moving.

OPERATING SOUNDS

Improvements in refrigeration design may produce sounds in your new refrigerator that are different or were not present in an older model. These improvements were made to create a refrigerator that is better at preserving food, is more energy efficient, and is quieter overall. Because new refrigerators run quieter, sounds may be detected that were present in older refrigerators, but were masked by higher sound levels. Many of these sounds are normal. Please note that the surfaces adjacent to a refrigerator, such as hard walls, floors and cabinetry may make these sounds seem even louder. The following are some of the normal sounds that may be noticed in a new refrigerator.

Sound	Possible Cause	Solution
Clicking	Freezer control (A) clicks when starting or stopping compressor.	Normal operation
	Motorized device (B) sounds like an electric clock and snaps in and out.	Normal operation
Air rushing or whirring	Freezer fan (C) and condenser fan (D) make this noise while operating.	Normal operation
Gurgling or boiling sound	Evaporator (E) and heat exchanger (F) refrigerant makes this noise when flowing.	Normal operation
Thumping	Ice cubes from ice maker drop into ice bucket (G) .	Normal operation
Vibrating noise	Compressor (H) makes a pulsating sound while running.	Normal operation.
	Refrigerator is not level.	See Installation Instructions for details on how to level your refrigerator
Buzzing	Ice maker water valve (I) hookup buzzes when ice maker fills with water.	Normal operation
Humming	Ice maker (J) is in the 'ON' position without water connection.	Stop sound by raising the ice maker arm to 'OFF' position (see page 7).
	Compressor (H) can make a high-pitched hum while operating.	Normal operation
Hissing or popping	Defrost heater (K) hisses, sizzles or pops when operational.	Normal operation

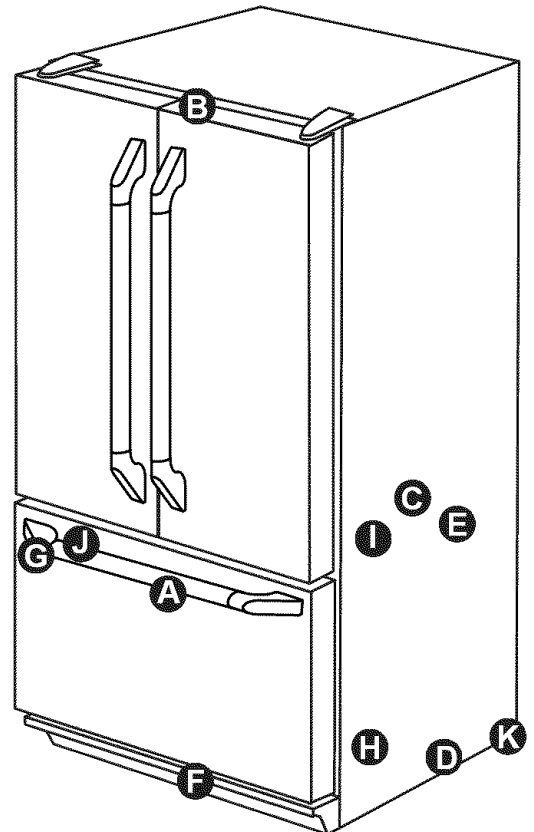

BEFORE YOU CALL FOR SERVICE

FRESH FOOD OR FREEZER DOOR DIFFICULT TO OPEN.

- Due to air flow between the compartments, it may be difficult to open the doors for several seconds after one of them is closed.

DISPENSER WILL NOT DISPENSE WATER OR ICE (SELECT MODELS).

- A water filter, or the filter bypass plug must be in place.
- Door is open.
- Water supply turned off.
- Water pressure too low.
- Lock switch on.
- Ice jam in the dispenser.
- Icemaker not operating.

WILL NOT RUN.

- Power cord not plugged in.
- No power at the electrical outlet.
- Circuit breaker tripped or house fuse blown.
- Main power turned **OFF (O)**.
- Touch the ON/OFF pad.
- Check Sabbath mode setting.

RUNS TOO LONG/TOO FREQUENTLY.

- Today's energy efficient refrigerators are larger and require more running time to maintain stable temperatures.
- Prolonged door openings.
- Too many door openings.
- Condenser needs cleaning.
- The door not sealing (due to a package or a container holding door open).
- Warm room temperature.

NOISY OPERATION.

- Cabinet not level.
- Weak floor.
- See Normal Operating Sounds

ODOR IN CABINET.

- Odor producing foods should be covered or wrapped.
- Interior needs cleaning.

CABINET VIBRATES.

- Cabinet not level.
- Weak floor.
- Improper installation.

MOISTURE ON INSIDE CABINET WALLS.

- Can occur during hot, humid weather with frequent or prolonged door openings.
- Door not closed properly.

EXCESSIVE MOISTURE IN OR AROUND DELI DRAWER.

- Food not wrapped properly.
- Hot, humid weather.

REFRIGERATOR COMPARTMENT TOO COLD.

- Refrigerator temperature set too cold.

REFRIGERATOR OR FREEZER COMPARTMENT TOO WARM.

- Refrigerator or freezer temperature set too warm.
- Prolonged door openings.

FREEZER NOT FREEZING PROPERLY.

- Products with high sugar content may not harden completely when frozen (ice cream, concentrated juice, etc.) Do not store in door.
- Adjust freezer temperature to a colder setting.

ICE CUBES EVAPORATE.

- Cold air moving over the ice cubes causes shrinkage, especially with limited usage. This is normal.

AUTOMATIC ICE MAKER NOT OPERATING.

- Wire lever arm in up (OFF) position.
- Water supply turned off.
- Water pressure too low.
- Freezer too warm.
- Install filter or filter bypass.

FRONT CABINET SURFACE WARM TO THE TOUCH.

- Special design to limit condensation during periods of high humidity.

WARRANTY & SERVICE

Product Maintenance

No maintenance, other than the **CARE AND CLEANING INSTRUCTIONS** identified in this **Use & Care Manual**, should be attempted by the owner/operator. All other maintenance and service must be performed by a qualified appliance technician.

If You Need Service...

First, review the recommended checks listed in the preceding **Before You Call for Service** section. Then, be certain that the appliance has been installed properly and is being operated correctly. Familiarize yourself with the warranty terms and conditions listed in the **PRODUCT WARRANTY** section.

If the above checks have been completed and the problem has not yet been remedied, call your local authorized DACOR service representative. Your dealer can normally provide the name and telephone number of the nearest service company.

DACOR works diligently to ensure your satisfaction when service is necessary. However, if you are not completely satisfied with the service provided, contact the company that performed the service and express why you are not pleased. Normally, they will be willing and able to resolve the problem.

If the service agency is not able to respond effectively, call or write the DACOR Customer Service.

Dacor Customer Service
1440 Bridge Gate Drive
Diamond Bar CA 91765

Telephone: 800-793-0093
Fax: 626-403-3130
Hours of Operation: Monday through Friday
6:00 am - 5:00 pm Pacific Time
Web Site: www.dacor.com

Please include your telephone number if you choose to write. We will then do our utmost to assure your happiness and satisfaction.

What is Covered

CERTIFICATE OF WARRANTIES
DACOR REFRIGERATORS

WITHIN THE FIFTY STATES OF THE U.S.A., THE DISTRICT OF COLUMBIA AND CANADA*:

FULL ONE YEAR WARRANTY

One (1) year - From the date of original retail purchase, any art that fails in normal home use will be repaired or replaced free of charge. Ice Maker - When purchased with the refrigerator and installed by the dealer the ice maker will be considered part of the refrigerator for warranty purposes.

LIMITED WARRANTY

Major Refrigeration Components

Second Through Fifth Year - After the first year from the date of original purchase, through the fifth year, Dacor will repair or replace, at its option, free of charge for parts and labor only, any part of the sealed refrigeration system (consisting of the compressor, evaporator, condenser, drier and connecting tubing) and the cabinet liner (exclusive of the door liner) which fail in normal home use. All other costs, including mileage, transportation, trip charge and diagnostic charge, if required, shall be the responsibility of the owner.

LIMITED WARRANTY

AquaClean Water Filter, if equipped

30 days - From the original retail purchase date, any part of the water filter cartridge which fails due to a defect in workmanship or materials will be replaced free of charge.

LIMITED WARRANTY

Other Parts

Second Year - Parts other than major refrigeration components which fail in normal home use during the second year following the date of original retail purchase will be repaired or provided free of charge for the part itself, with the owner paying all other costs, including labor, mileage, transportation, trip charge and diagnostic charge, if required.

NOTE

The full warranty and the limited warranties apply when the refrigerator is located in the United States or Canada. Refrigerators located elsewhere are covered by the limited warranties only including parts that fail during the first year.

CANADIAN RESIDENTS

The above warranties only cover an appliance installed in Canada that has been certified or listed by appropriate test agencies for compliance to a National Standard of Canada unless the appliance was brought into Canada due to transfer of residence from the United States to Canada.

LIMITATIONS OF LIABILITY

The warrantor shall not be liable for any incidental or consequential damages, including food loss. Some states do not allow the exclusion or limitation of consequential damages, so the above limitation or exclusion may not apply to you.

WARRANTY & SERVICE

What is Not Covered

1. Conditions and damages resulting from any of the following:
 - a. Improper installation, delivery, or maintenance.
 - b. Any repair, modification, alteration, or adjustment not authorized by the manufacturer or an authorized servicer.
 - c. Misuse, abuse, accidents, or unreasonable use.
 - d. Incorrect electric current, voltage, or supply.
 - e. Improper setting of any control.
2. Warranties are void if the original serial numbers have been removed, altered or cannot be readily determined.
3. Light bulbs.
4. Products purchased for commercial or industrial use.
5. The cost of service or service call to:
 - a. Correct installation errors.
 - b. Instruct the user on the proper use of the product.
 - c. Transport the appliance to the servicer.
6. Consequential or incidental damages sustained by any person as a result of any breach of these warranties. Some states do not allow the exclusion or limitation of consequential or incidental damages, so the above exclusion may not apply.

fold here

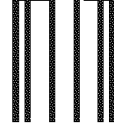

NO POSTAGE
NECESSARY
IF MAILED
IN THE
UNITED STATES

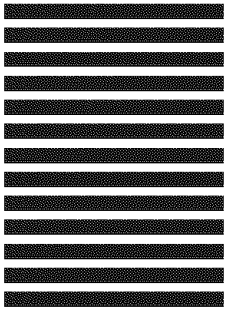

BUSINESS REPLY MAIL
FIRST-CLASS MAIL PERMIT NO. 4507 DIAMOND BAR CA

POSTAGE WILL BE PAID BY ADDRESSEE

ATTN: WARRANTY PROCESSING DEPT
DACOR
1440 BRIDGEGATE DR STE 200
PO BOX 6532
DIAMOND BAR CA 91765-9861





Please visit www.dacor.com to activate your warranty online.

WARRANTY INFORMATION



IMPORTANT:

Your warranty for this product **CANNOT BE ACTIVATED** until this form has been returned to Dacor. If you have purchased more than one Dacor product, Please return all forms in one envelope.

Please rest assured that under no conditions will Dacor sell your name or any of the information on this form for mailing list purposes. We are very grateful that you have chosen Dacor products for your home and do not consider the sale of such information to be a proper way of expressing our gratitude!

(Please Print or Type)

Owner's Name: _____
Last First Middle

Street: _____

City: _____ State: _____ Zip: _____

Purchase Date: _____ Email: _____ Telephone: _____

Dealer: _____

City: _____ State: _____ Zip: _____

Your willingness to take a few seconds to fill in the section below will be sincerely appreciated. Thank you.

1. How were you **first** exposed to Dacor products? (Please check one only.)

- A. T.V. Cooking Show
- B. Magazine
- C. Appliance Dealer Showroom
- D. Kitchen Dealer Showroom
- E. Home Show
- F. Builder
- G. Architect/Designer
- H. Another Dacor Owner
- I. Model Home
- J. Other _____

2. Where did you buy your Dacor appliances?

- A. Appliance Dealer
- B. Kitchen Dealer
- C. Builder Supplier
- D. Builder
- E. Other _____

3. For what purpose was the product purchased?

- A. Replacement **only**
- B. Part of a Remodeled
- C. New Home
- D. Other _____

4. What is your household income?

- A. Under \$75,000
- B. \$75,000 – \$100,000
- C. \$100,000 – \$150,000
- D. \$150,000 – \$200,000
- E. \$200,000 – \$250,000
- F. Over \$250,000

5. What other brands of appliances do you have in your kitchen?

- A. Cooktop _____
- B. Oven _____
- C. Dishwasher _____
- D. Refrigerator _____

6. Would you buy or recommend another Dacor product?

- Yes
- No

Comments: _____

Thank you very much for your assistance. The information you have provided will be extremely valuable in helping us plan for the future and giving you the support you deserve.

cut here

cut here