

PRO-FORM[®] 400e CROSSWALK

Model No. 831.29633.0

Serial No. _____

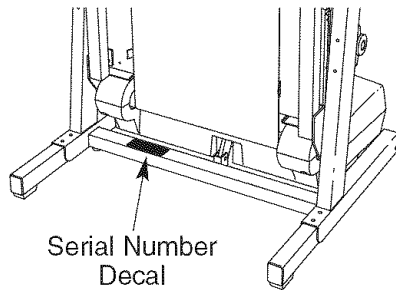

- Assembly
- Operation
- Maintenance
- Part List and Drawing

CAUTION

Read all precautions and instructions in this manual before using this equipment. Save this manual for future reference.

TREADMILL EXERCISER User's Manual

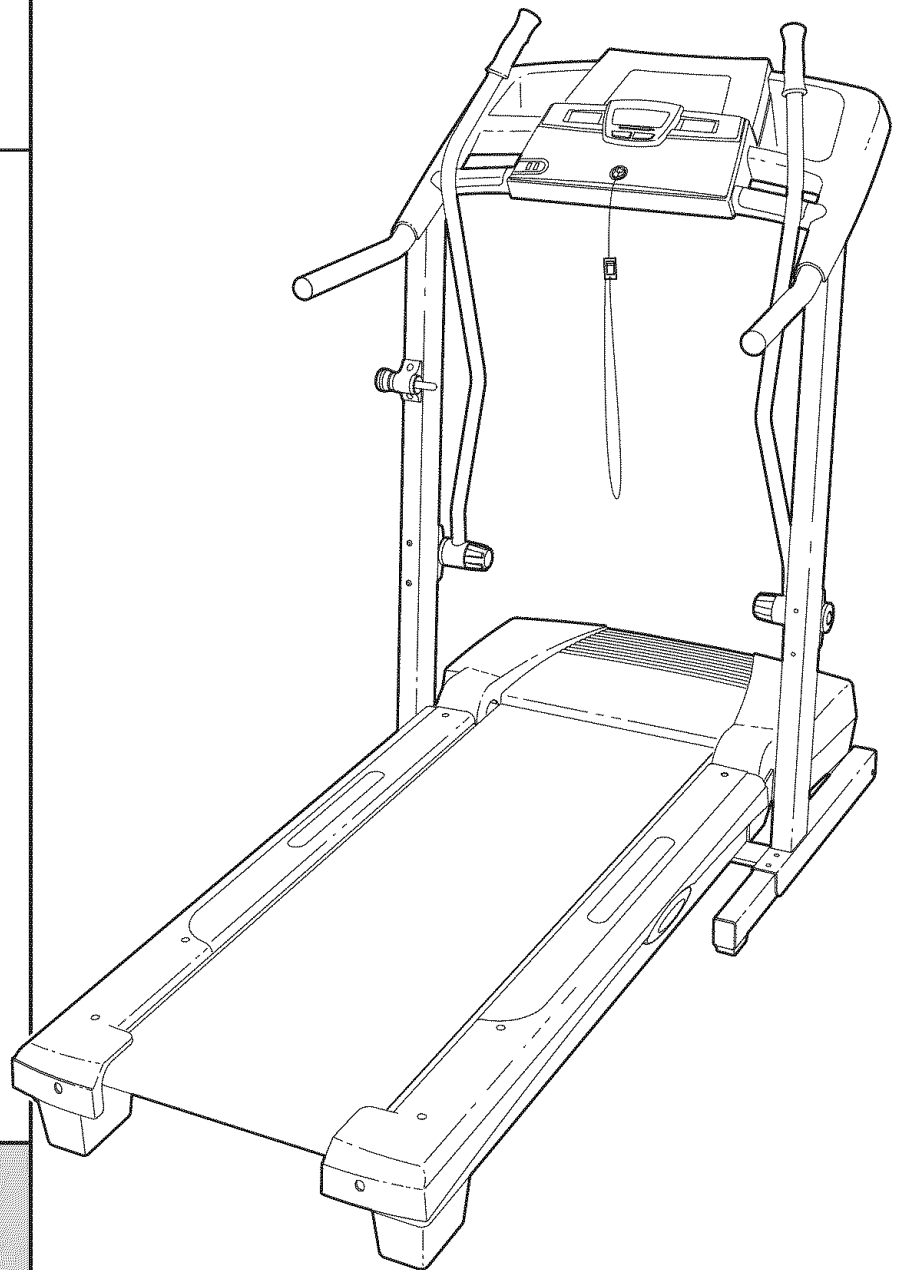

Sears, Roebuck and Co., Hoffman Estates, IL 60179

PRO-FORM 400e **CROSSWALK**

TABLE OF CONTENTS

| | |
|--|------------|
| IMPORTANT PRECAUTIONS | 3 |
| BEFORE YOU BEGIN | 5 |
| ASSEMBLY | 6 |
| OPERATION AND ADJUSTMENT | 10 |
| HOW TO FOLD AND MOVE THE TREADMILL | 15 |
| TROUBLESHOOTING | 17 |
| CONDITIONING GUIDELINES | 19 |
| ORDERING REPLACEMENT PARTS | Back Cover |
| FULL 90 DAY WARRANTY | Back Cover |

Note: An EXPLODED DRAWING and a PART LIST are attached in the center of this manual.

IMPORTANT PRECAUTIONS

⚠ WARNING: To reduce the risk of burns, fire, electric shock, or injury to persons, read the following important precautions and information before operating the treadmill.

1. It is the responsibility of the owner to ensure that all users of this treadmill are adequately informed of all warnings and precautions.
2. Use the treadmill only as described.
3. Place the treadmill on a level surface, with at least eight feet of clearance behind it and two feet on each side. Do not place the treadmill on any surface that blocks air openings. To protect the floor or carpet from damage, place a mat under the treadmill.
4. Keep the treadmill indoors, away from moisture and dust. Do not put the treadmill in a garage or covered patio, or near water.
5. Do not operate the treadmill where aerosol products are used or where oxygen is being administered.
6. Keep children under the age of 12 and pets away from the treadmill at all times.
7. The treadmill should be used only by persons weighing 250 pounds or less.
8. Never allow more than one person on the treadmill at a time.
9. Wear appropriate exercise clothes when using the treadmill. Do not wear loose clothes that could become caught in the treadmill. Athletic support clothes are recommended for both men and women. *Always wear athletic shoes. Never use the treadmill with bare feet, wearing only stockings, or in sandals.*
10. When connecting the power cord (see page 10), plug the power cord into a surge suppressor (not included) and plug the surge suppressor into a grounded circuit capable of carrying 15 or more amps. No other appliance should be on the same circuit. Do not use an extension cord.
11. Use only a single-outlet surge suppressor that meets all of the specifications described on page 10. To purchase a surge suppressor, see your local Sears store or call 1-800-366-7278 and order part number 146148, or see your local electronics store.
12. Failure to use a properly functioning surge suppressor could result in damage to the control system of the treadmill. If the control system is damaged, the walking belt may change speed, accelerate, or stop unexpectedly, which may result in a fall and serious injury.
13. Keep the power cord and the surge suppressor away from heated surfaces.
14. Never move the walking belt while the power is turned off. Do not operate the treadmill if the power cord or plug is damaged, or if the treadmill is not working properly. (See TROUBLESHOOTING on page 17 if the treadmill is not working properly.)
15. Read, understand, and test the emergency stop procedure before using the treadmill (see OPERATION and ADJUSTMENT).
16. Never start the treadmill while you are standing on the walking belt. Always hold the handrails or the upper body arms while using the treadmill.
17. The treadmill is capable of high speeds. Adjust the speed in small increments to avoid sudden jumps in speed.
18. The pulse sensor is not a medical device. Various factors, including the user's movement, may affect the accuracy of heart rate readings. The pulse sensor is intended only as an exercise aid in determining heart rate trends in general.
19. Never leave the treadmill unattended while it is running. Always remove the key and unplug the power cord when the treadmill is not in use.
20. Do not attempt to raise, lower, or move the treadmill until it is properly assembled. (See ASSEMBLY on page 6, and HOW TO FOLD AND MOVE THE TREADMILL on page 15.) You must be able to safely lift 45 pounds (20 kg) to raise, lower, or move the treadmill.

21. When folding or moving the treadmill, make sure that the storage latch is fully closed.

22. Inspect and properly tighten all parts of the treadmill regularly.

23. Never insert any object into any opening.

24. **DANGER:** Always unplug the power cord immediately after use, before cleaning the treadmill, and before performing the main-

tenance and adjustment procedures described in this manual. Never remove the motor hood unless instructed to do so by an authorized service representative. Servicing other than the procedures in this manual should be performed by an authorized service representative only.

25. This treadmill is intended for in-home use only. Do not use this treadmill in a commercial, rental, or institutional setting.

WARNING: Before beginning this or any exercise program, consult your physician. This is especially important for persons over the age of 35 or persons with pre-existing health problems. Read all instructions before using. Sears assumes no responsibility for personal injury or property damage sustained by or through the use of this product.

SAVE THESE INSTRUCTIONS

The decals shown have been placed on your treadmill. If a decal is missing, or if it is not legible, call toll-free 1-888-533-1333 and order a free replacement decal (see the front cover of this manual). Apply the decal in the location shown. Note: The decals are not shown at actual size.

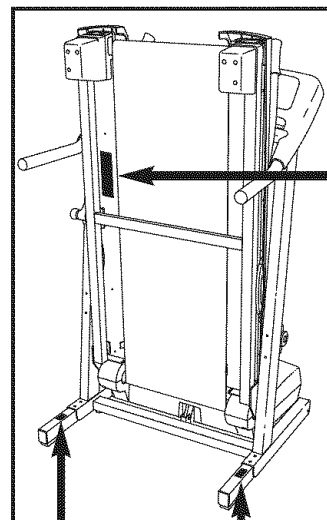

CAUTION
KEEP HANDS AND FEET AWAY FROM THIS AREA WHILE THE TREADMILL IS IN OPERATION.

WARNING:

Protect yourself and others from risk of serious injury. Read the user's manual and :



- Stand only on the side rails when starting or stopping treadmill.

- Change speed in small increments.

- Hold handrails to prevent falling, and always wear the safety clip while operating treadmill.

- Stop if you feel faint, dizzy, or short of breath.

- Fully engage storage latch before treadmill is moved or stored.

- Reduce incline to its lowest level before folding treadmill into storage position.



- Never allow children on or around treadmill.

- Remove key when not in use.



- Keep clothing, fingers, and hair away from moving belt.

- Never try to adjust or fix the belt while it is moving.

- Always wear athletic shoes while operating treadmill.

BEFORE YOU BEGIN

Thank you for selecting the PROFORM® CROSSWALK 400e treadmill. The CROSSWALK 400e treadmill combines advanced technology with innovative design to help you achieve your fitness goals in the convenience and privacy of your home. And when you're not exercising, the CROSSWALK 400e treadmill can be folded up, requiring less than half the floor space of other treadmills.

For your benefit, read this manual carefully before

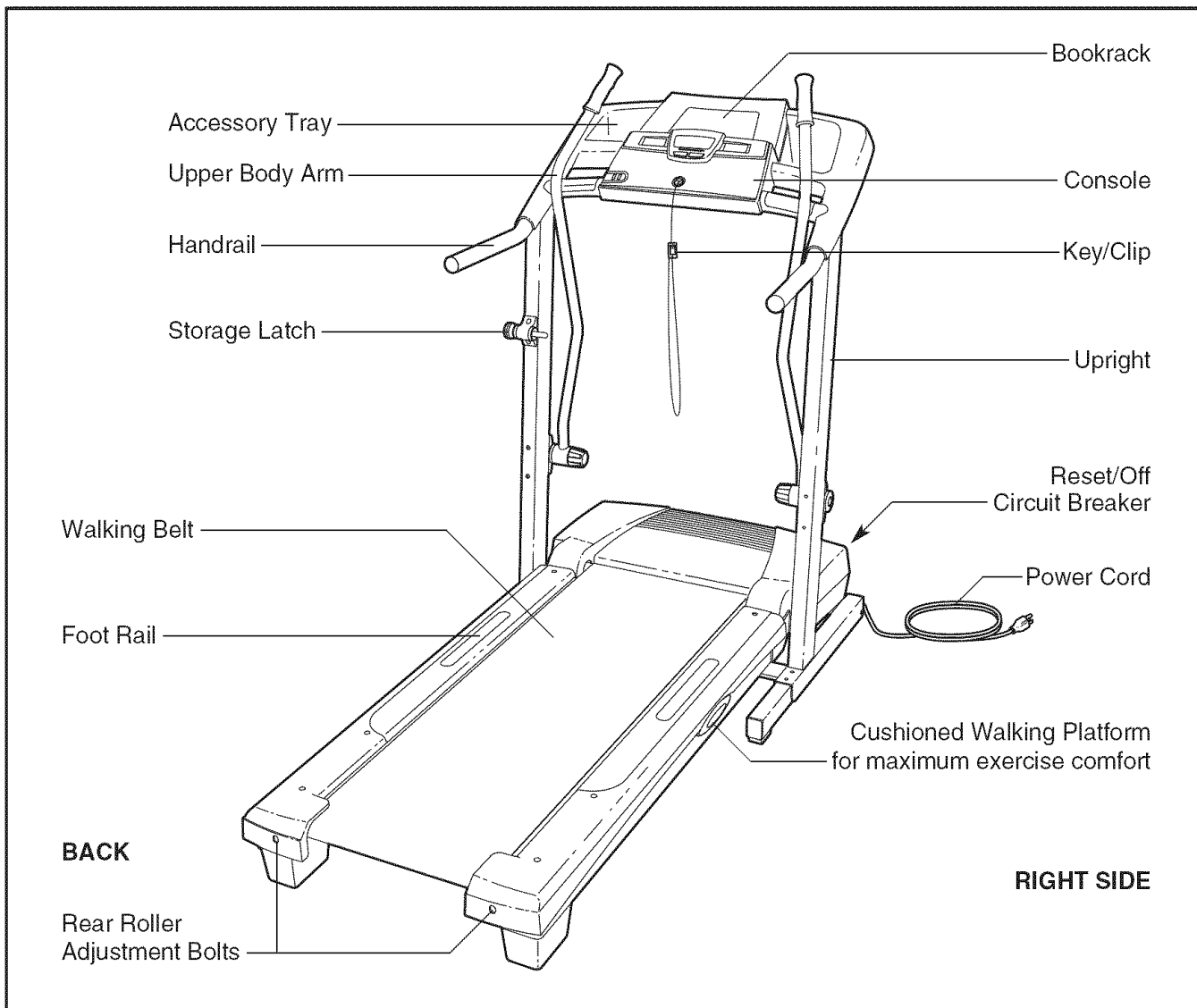

using the treadmill. If you have questions after reading this manual, call 1-800-4-MY-HOME® (1-800-469-4663). To help us assist you, please note the product model number and serial number before calling. The model number of the treadmill is 831.29633.0. The serial number can be found on a decal attached to the treadmill (see the front cover of this manual for the location).

Before reading further, please review the drawing below and familiarize yourself with the labeled parts.

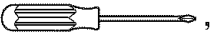

ASSEMBLY

Assembly requires two persons. Set the treadmill in a cleared area and remove all packing materials; do not dispose of the packing materials until assembly is completed. Note: The underside of the treadmill walking belt is coated with high-performance lubricant. During shipping, a small amount of lubricant may be transferred to the top of the walking belt or the shipping carton. This is a normal condition and does not affect treadmill performance. If there is lubricant on top of the walking belt, simply wipe off the lubricant with a soft cloth and a mild, non-abrasive cleaner.

Assembly requires the included allen wrenches  and your own phillips screwdriver , rubber mallet , and adjustable wrench .

For help identifying the assembly hardware, see the drawings below. If a part is not in the parts bag, first check to see if it has been pre-assembled. **If a part is missing, call toll-free 1-888-533-1333.**

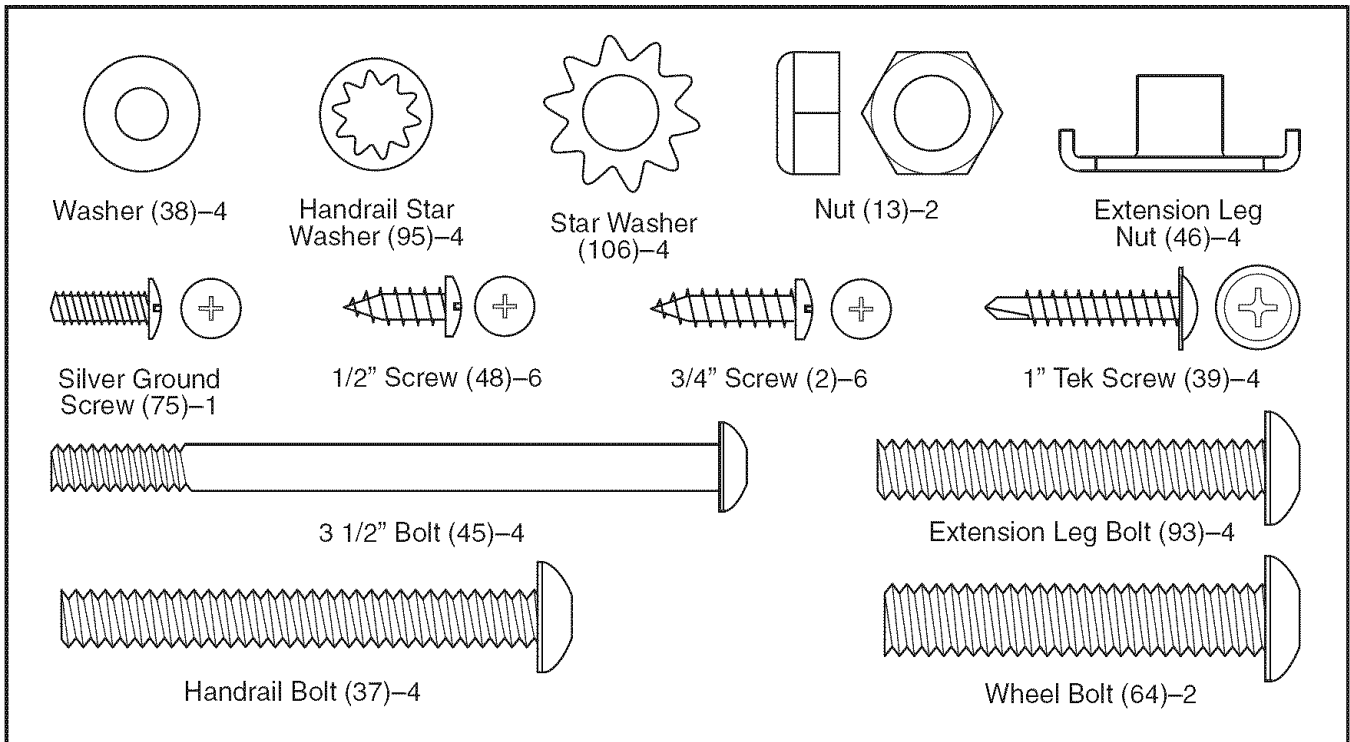

1. Make sure that the power cord is unplugged.

With the help of a second person, carefully tip the treadmill onto its left side as shown. Partially fold the Frame (86) so the treadmill is more stable. **Do not fully fold the treadmill until it is completely assembled.**

Insert an Extension Leg (63) into the base of the Uprights (69) with the Extension Leg Pad (61) oriented as shown. If necessary, use a rubber mallet to fully insert the Extension Leg. Next, hold two Extension Leg Nuts (46) in the bottom of the Extension Leg, and insert two Extension Leg Bolts (93) into the top of the Extension Leg. Firmly tighten the Extension Leg Bolts into the Extension Leg Nuts.

Attach two Base Pads (57) to the base of the Uprights (69) with two 1" Tek Screws (39).

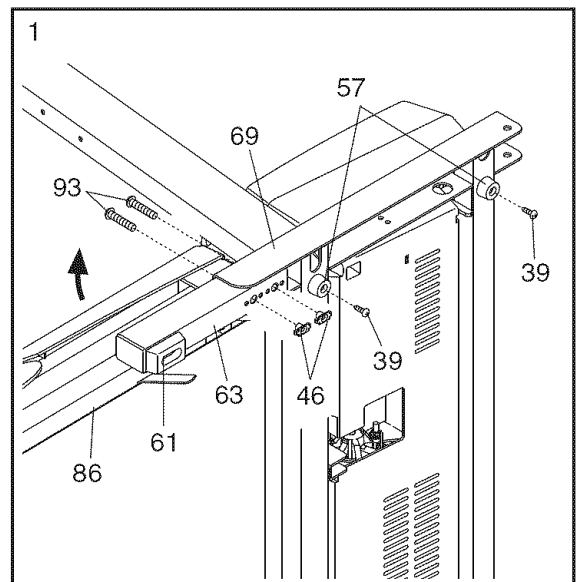

- Attach a Wheel (66) to the base of the Uprights (69) with a Wheel Bolt (64) and a Nut (13) as shown. **Do not overtighten the Bolt;** the Wheel should turn freely.

With the help of a second person, carefully tip the treadmill onto its other side. See assembly step 1, and attach the other Extension Leg (63) and the remaining two Base Pads (57). Then, attach the other Wheel (66) as described above.

With the help of a second person, carefully lower the base of the Uprights (69) to the floor so the Uprights are in a vertical position.

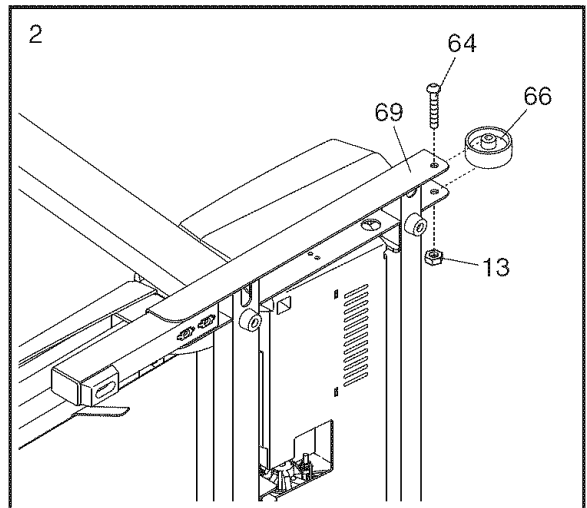

- If there is a board between the Uprights (69), remove the board and the two bolts. Discard the board and the bolts.

Identify the Right Handrail (72), which has a large hole in the left side. Remove the wire tie securing the Upright Wire (42) inside of the right Upright (69). Feed the Upright Wire into the hole in the bottom of the Right Handrail and out of the large hole in the side. Note: It may be helpful to use needlenose pliers to pull the Wire Harness out of the hole.

Set the Right Handrail (72) on the right Upright (69). Attach the Right Handrail with two Handrail Bolts (37) and two Handrail Star Washers (95). **Be careful not to pinch the Upright Wire (42).**

Attach the Left Handrail (71) as described above. Note: There is not an upright wire on the left side.

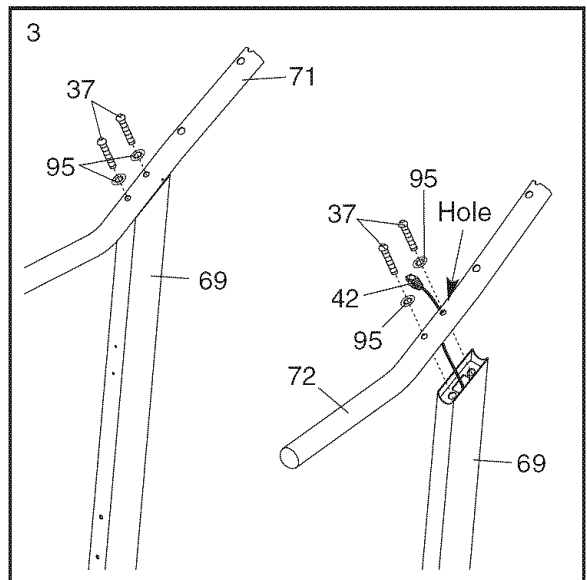

- Hold the Console Base (47) near the Left Handrail (71). Attach the end of the ground wire on the Console Base to the indicated small hole in the Left Handrail with the Silver Ground Screw (75).

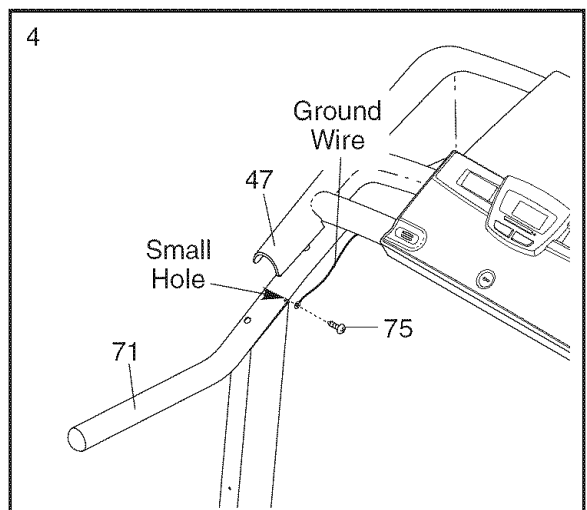

5. **Touch the Right Handrail (72) to discharge any static.** Slide the sleeve off the connector on the Upright Wire (42) as shown in the inset drawing. Next, press the end of the Upright Wire into the socket in the bottom of the Console Base (47). **The connector should slide easily into the socket and snap into place.** If the connector does not slide easily and snap into place, turn the connector and then insert it. Then, slide the sleeve back over the connector.

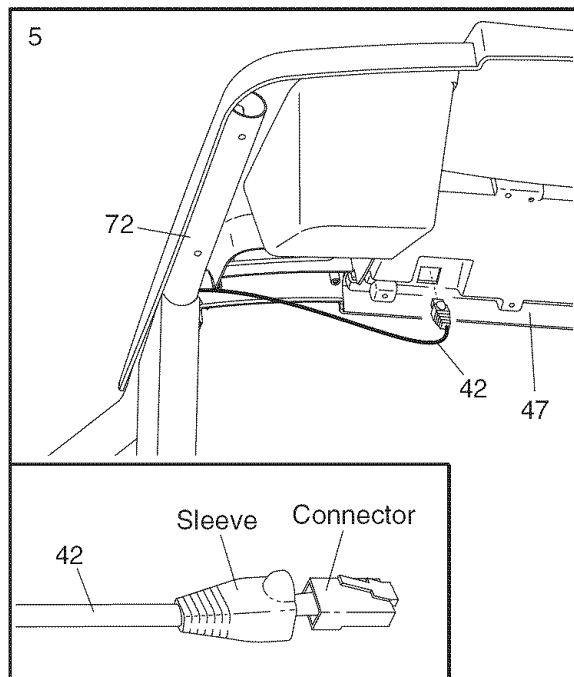

6. Set the Console Base (47) on the Handrails (71, 72). Attach the Console Base with four 3/4" Screws (2). **Start all four Screws before tightening them; do not over-tighten the Screws.**

See the lower drawing. **Make sure that the Upright Wire (42) is routed below the two indicated round posts (A).** Next, press the Upright Wire into the slot between the square post (B) and the Console Base (47).

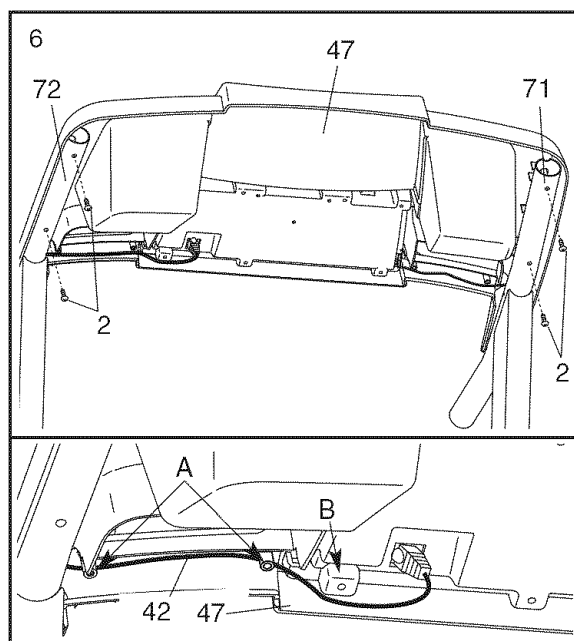

7. Cover the Upright Wire (42) with the Right Grip Plate (36). **Be careful not to pinch the Upright Wire.** Tighten three 1/2" Screws (48) into the Right Grip Plate and the Console Base (47).

Attach the Left Grip Plate (32) over the ground wire and the other wires with three 1/2" Screws (48). **Be careful not to pinch any of the wires.**

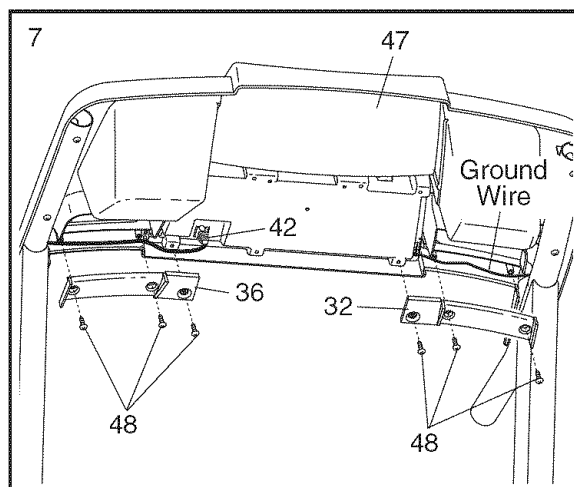

8. Attach the Left Upper Body Arm (24) to the left Upright (69) with two 3 1/2" Bolts (45), two Washers (38), and two Star Washers (106) as shown. **Make sure that the Left Upper Body Arm is on the indicated side of the Console Base (47).**

Attach the Right Upper Body Arm (not shown) to the right Upright (not shown) in the same way.

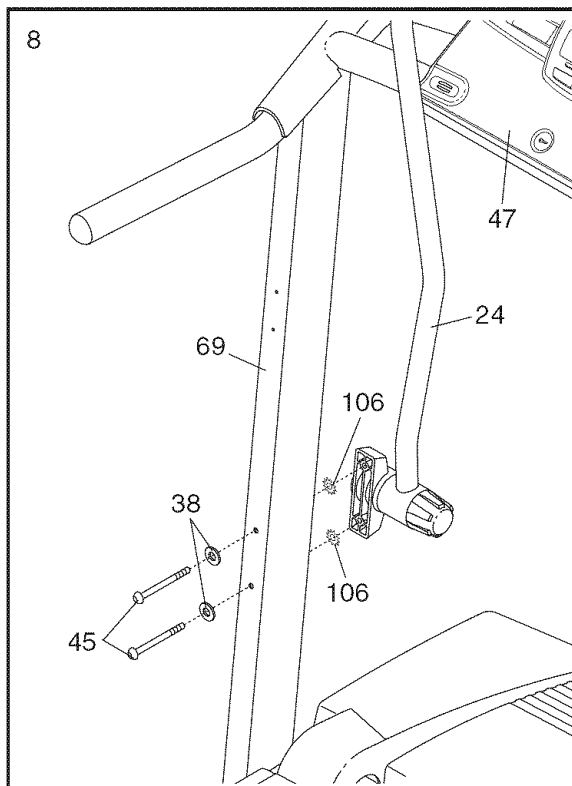

9. Attach the Latch Housing (29) to the left Upright (69) with two 3/4" Screws (2). **Make sure that the large hole in the Latch Housing is on the side shown.**

Remove the knob from the pin. **Make sure that the collar and the spring are on the pin as shown.** Then, insert the pin into the Latch Housing (29), and tighten the knob back onto the pin.

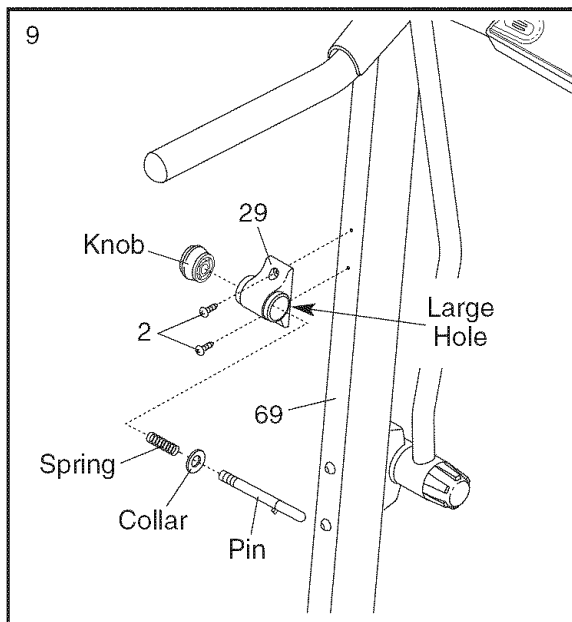

10. **Make sure that all parts are properly tightened before you use the treadmill.** Note: Extra hardware may be included. Keep the included allen wrenches in a secure place; the large allen wrench is used to adjust the walking belt (see page 17). To protect the floor or carpet, place a mat under the treadmill.

OPERATION AND ADJUSTMENT

THE PRE-LUBRICATED WALKING BELT

Your treadmill features a walking belt coated with high-performance lubricant. **IMPORTANT: Never apply silicone spray or other substances to the walking belt or the walking platform.** Such substances will deteriorate the walking belt and cause excessive wear.

HOW TO PLUG IN THE POWER CORD

⚠ DANGER: Improper connection of the equipment-grounding conductor can result in an increased risk of electric shock. Check with a qualified electrician or serviceman if you are in doubt as to whether the product is properly grounded. Do not modify the plug provided with the product—if it will not fit the outlet, have a proper outlet installed by a qualified electrician.

Your treadmill, like any other type of sophisticated electronic equipment, can be seriously damaged by sudden voltage changes in your home's power. Voltage surges, spikes, and noise interference can result from weather conditions or from other appliances being turned on or off. **To decrease the possibility of your treadmill being damaged, always use a surge suppressor with your treadmill (see drawing 1 at the right).** To purchase a surge suppressor, see your local Sears store or call 1-800-366-7278 and order part number 146148, or see your local electronics store.

Use only a single-outlet surge suppressor that is UL 1449 listed as a transient voltage surge suppressor (TVSS). The surge suppressor must have a UL suppressed voltage rating of 400 volts or less and a minimum surge dissipation of 450 joules. The surge suppressor must be electrically rated for 120 volts AC and 15 amps. There must be a monitoring light on the surge suppressor to indicate whether it is functioning properly. Failure to use a properly functioning surge suppressor could result in damage to the control system of the treadmill. If the control system is damaged, the walking belt may change speed, accelerate, or stop unexpectedly, which may result in a fall and serious injury.

This product must be grounded. If it should malfunction or break down, grounding provides a path of least resistance for electric current to reduce the risk of electric shock. This product is equipped with a cord having

an equipment-grounding conductor and a grounding plug. **Plug the power cord into a surge suppressor, and plug the surge suppressor into an appropriate outlet that is properly installed and grounded in accordance with all local codes and ordinances. Important: The treadmill is not compatible with GFCI-equipped outlets.**

This product is for use on a nominal 120-volt circuit, and has a grounding plug that looks like the plug illustrated in drawing 1 below. A temporary adapter that looks like the adapter illustrated in drawing 2 may be used to connect the surge suppressor to a 2-pole receptacle as shown in drawing 2 if a properly grounded outlet is not available.

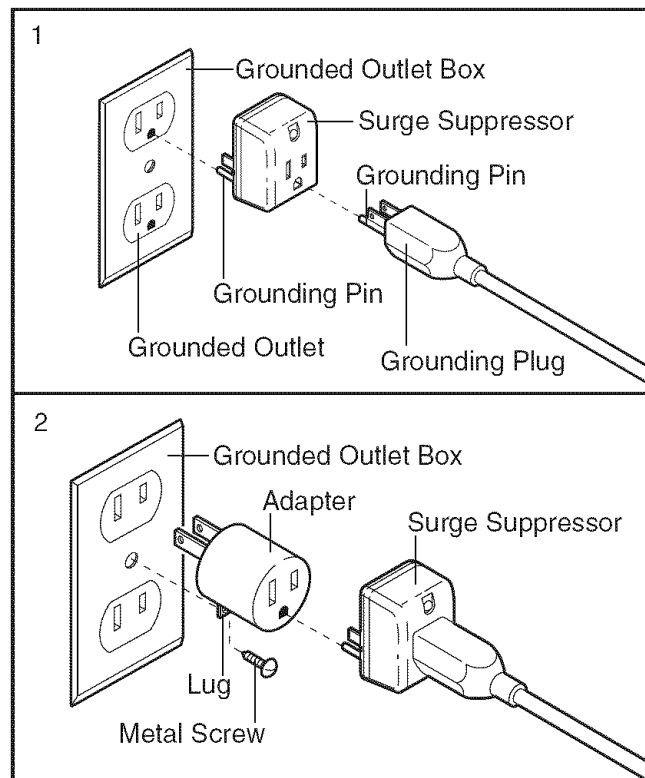

The temporary adapter should be used only until a properly grounded outlet (drawing 1) can be installed by a qualified electrician.

The green-colored rigid ear, lug, or the like extending from the adapter must be connected to a permanent ground such as a properly grounded outlet box cover. Whenever the adapter is used it must be held in place by a metal screw. **Some 2-pole receptacle outlet box covers are not grounded. Contact a qualified electrician to determine if the outlet box cover is grounded before using an adapter.**

CONSOLE DIAGRAM

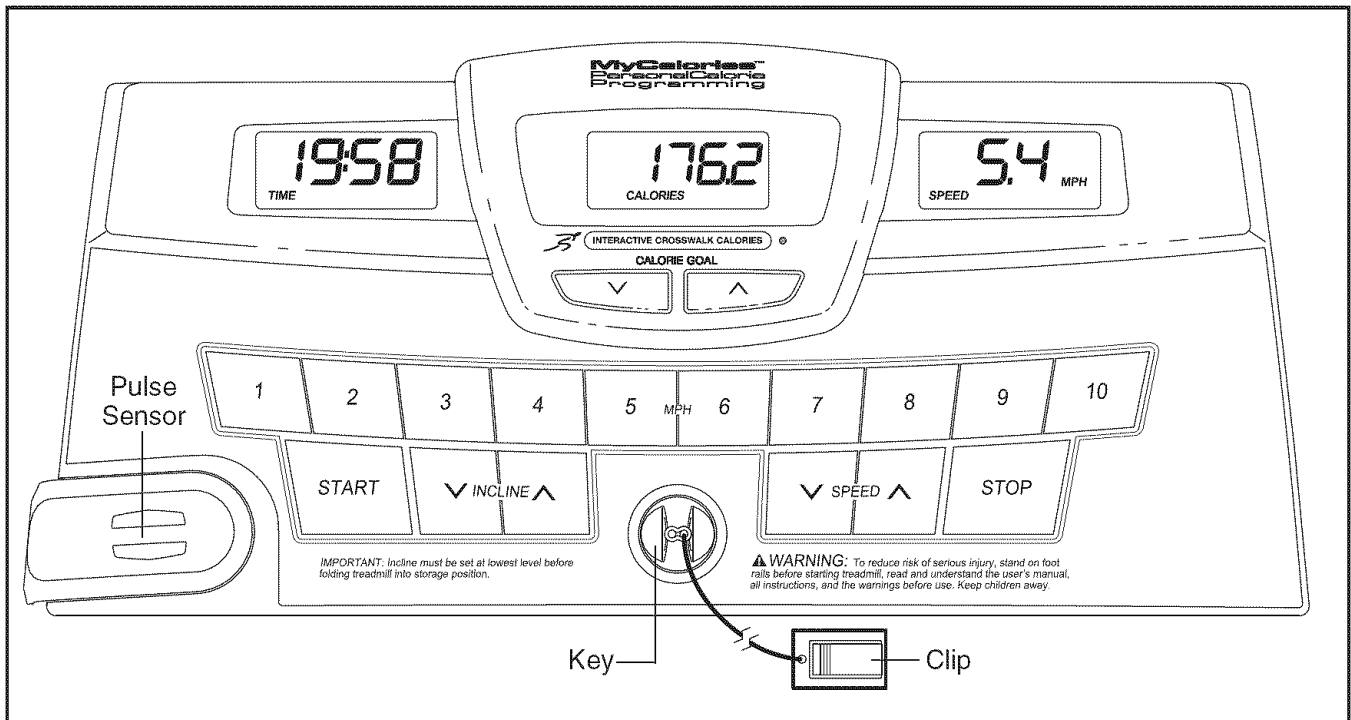

FEATURES OF THE CONSOLE

The treadmill console offers a selection of features designed to make your workouts more effective. During each workout, you can change the speed and incline of the treadmill with the touch of a button. As you exercise, the console will display continuous exercise feedback. You can even measure your heart rate using the built-in pulse sensor.

MyCalories™ Personal Calorie Programming

The center display of the console will show the approximate number of calories you have burned. If desired, you can program a calorie goal before each workout, and the console will count down the calories until you reach your goal.

Note: If there is a sheet of clear plastic on the console, peel off the plastic. To prevent damage to the walking platform, always wear clean shoes while using the treadmill. The first time you use the treadmill, periodically inspect the alignment of the walking belt, and center the walking belt if necessary (see page 18).

HOW TO TURN ON THE POWER

Plug in the power cord (see page 10). Next, locate the reset/off circuit breaker on the treadmill frame near the power cord. Make sure that the circuit breaker is in the “reset” position.

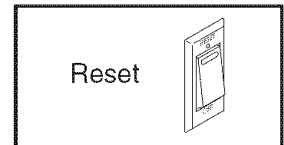

Next, stand on the foot rails of the treadmill. Locate the clip attached to the key (see the drawing above), and slide the clip securely onto the waistband of your clothes. Then, insert the key into the console. After a moment, the displays will light. **Important:** In an emergency situation, the key can be pulled from the console, causing the walking belt to slow to a stop. Test the clip by carefully taking a few steps backward; if the key is not pulled from the console, adjust the position of the clip.

CONSOLE OPERATION

1 Insert the key into the console.

See HOW TO TURN ON THE POWER on page 11.

2 Program a calorie goal if desired.

To program a calorie goal for your workout, press the increase button below the center display. A goal of 100 calories will appear in the center display. To increase or decrease the goal in increments of 50 calories, press the increase or decrease button repeatedly.



3 Start the walking belt.

To start the walking belt, press the Start button, the Speed increase button, or one of the ten numbered buttons.

If the Start button or the Speed increase button is pressed, the walking belt will begin to move at 1 mph. As you exercise, change the speed of the walking belt as desired by pressing the Speed increase and decrease buttons. Each time a button is pressed, the speed setting will change by 0.1 mph; if a button is held down, the speed setting will change in increments of 0.5 mph. Note: After a button is pressed, it may take a moment for the walking belt to reach the selected speed setting.

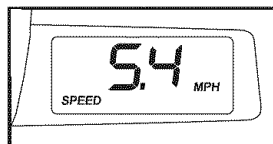

If one of the ten numbered buttons is pressed, the walking belt will gradually increase in speed until it reaches the selected speed setting.

To stop the walking belt, press the Stop button. The time will begin to flash in the left display. To restart the walking belt, press the Start button, the Speed increase button, or one of the ten numbered buttons.

4 Change the incline of the treadmill as desired.

To change the incline of the treadmill, press the Incline increase or decrease button until the desired incline level is reached.

5 Follow your progress with the three displays.

The left display—This display will show the elapsed time and the distance that you have walked or run during your workout. The display will change from one number to the other every few seconds.

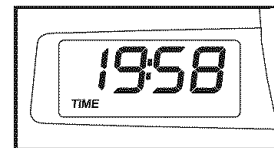

Note: The console can display distance and speed in either miles or kilometers, as shown by the letters MPH or Km/H in the right display. To change the unit of measurement, see THE INFORMATION MODE/DEMO MODE on page 13. **For simplicity, all instructions in this section refer to miles.**

The center display—

The center display will show the approximate number of calories you have burned during your workout.

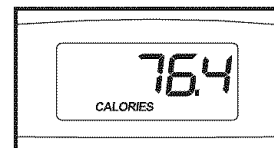

Note: If you have programmed a calorie goal, the center display will show the number of calories still to be burned. When you reach your goal, a series of tones will sound, the walking belt will slow to a stop, and the time will begin to flash in the left display. If you want to continue exercising, go to step 3 on this page.

When you use the treadmill's upper body arms, press the INTERACTIVE CROSSWALK CALORIES button so the indicator on the right side of the button is lit. The console will then include your upper body exercise as it counts the approximate number of calories you have burned.

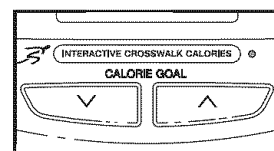

The right display—

The right display will show the speed of the walking belt. The right display will also show your heart rate when you use the pulse sensor (see step 6 below).

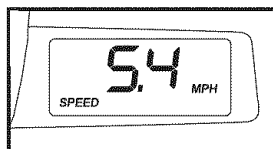

To reset the displays, press the Stop button, remove the key, and then reinsert the key.

6 Measure your heart rate if desired.

To measure your heart rate, **stand on the foot rails** and place your left thumb on the pulse sensor. **Do not press too hard, or the circulation in your thumb will be restricted and your pulse will not be detected.** When your pulse is detected, a heart-shaped indicator in the right display will flash each time your heart beats, one or two dashes will appear, and then your heart rate will be shown. **For the most accurate heart rate reading, hold your thumb on the pulse sensor for at least 15 seconds.**

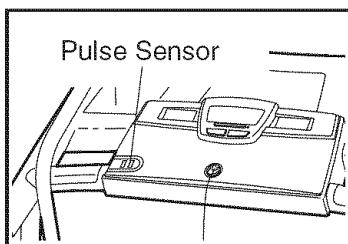

If the displayed heart rate appears to be too high or too low, or if your heart rate is not displayed, lift your thumb off the pulse sensor for a few seconds. Then, reposition your thumb on the pulse sensor. Remember to stand still while measuring your heart rate.

7 When you are finished exercising, remove the key.

Step onto the foot rails, press the Stop button, and **adjust the incline of the treadmill to the lowest setting. The incline must be at the lowest setting when the treadmill is folded to the storage position, or the treadmill will become damaged.** Next, remove the key from the console and put it in a se-

cure place. **Note: If the displays remain lit after the key is removed, the console is in the “demo” mode. See THE INFORMATION MODE/DEMO MODE on this page and turn off the demo mode.**

When you are finished using the treadmill, switch the reset/off circuit breaker to the “off” position and unplug the power cord.

THE INFORMATION MODE/DEMO MODE

The console features an information mode that keeps track of treadmill usage information and allows you to select a unit of measurement for the console.

To select the information mode, insert the key into the console while holding down the Stop button, and then release the Stop button. When the information mode is selected, the following information will be shown:

The left display will show the total number of hours that the treadmill has been used and the total number of miles (or kilometers) that the walking belt has moved.

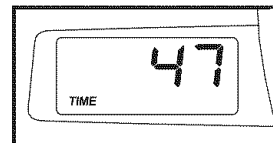

An “E” (for English) or an “M” (for metric) will appear in the right display. Press the Speed increase button to change the unit of measurement, if desired. **IMPOR-**

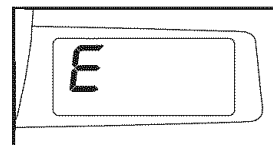

TANT: If a “d” appears in the right display, the console is in the “demo” mode. This mode is intended to be used only when a treadmill is displayed in a store. When the console is in the demo mode, the power cord can be plugged in, the key can be removed from the console, and the displays will remain lit; the buttons will not operate. **If a “d” appears when the information mode is selected, press the Speed decrease button so the “d” disappears.**

To exit the information mode, remove the key from the console.

HOW TO USE THE UPPER BODY ARMS

As you walk on the treadmill, you can hold the handrails or use the upper body arms. To exercise your arms, shoulders, and back for a total body workout, move the upper body arms forward and back as you walk on the treadmill.

To vary the intensity of your upper body exercise, the resistance of the upper body arms can be adjusted. To increase the resistance, turn the resistance knobs clockwise; to decrease the resistance, turn the knobs counterclockwise.

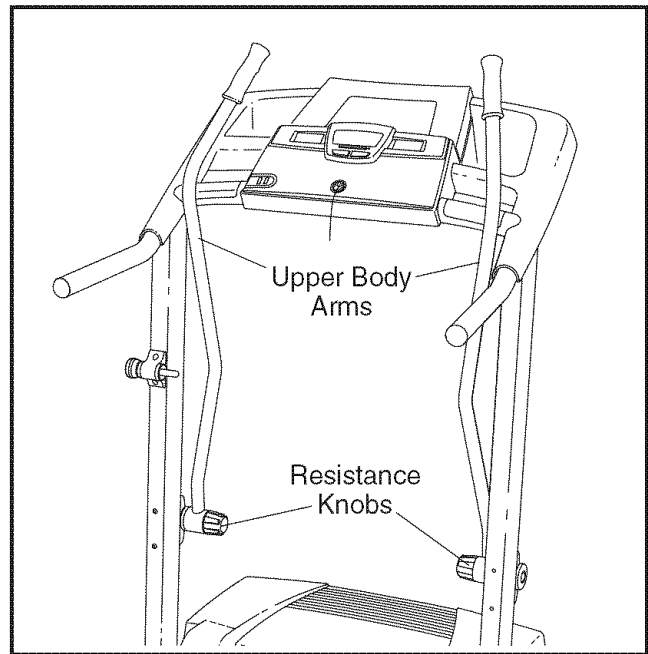

HOW TO FOLD AND MOVE THE TREADMILL

HOW TO FOLD THE TREADMILL FOR STORAGE

Before folding the treadmill, adjust the incline to the lowest position. If this is not done, the treadmill may become permanently damaged. Next, unplug the power cord. **CAUTION:** You must be able to safely lift 45 pounds (20 kg) to raise, lower, or move the treadmill.

1. Hold the metal frame firmly in the location shown by the arrow at the right. **CAUTION:** To decrease the possibility of injury, do not lift the frame by the plastic foot rails. Bend your legs and keep your back straight; as you raise the frame, make sure to lift with your legs rather than your back. Raise the frame about halfway to the vertical position.
2. Move your right hand to the position shown and hold the treadmill firmly. Using your left hand, pull the latch knob to the left and hold it. Raise the frame until the hole in the frame is aligned with the latch pin. Slowly release the latch knob; **make sure that the latch pin is fully inserted into the frame.**

To protect the floor or carpet from damage, place a mat under the treadmill. Keep the treadmill out of direct sunlight. Do not leave the treadmill in the storage position in temperatures above 85° Fahrenheit.

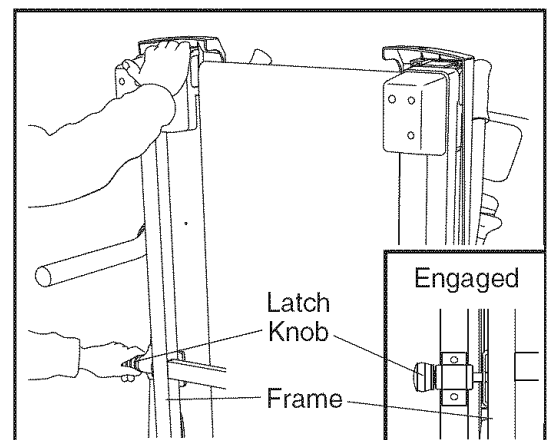
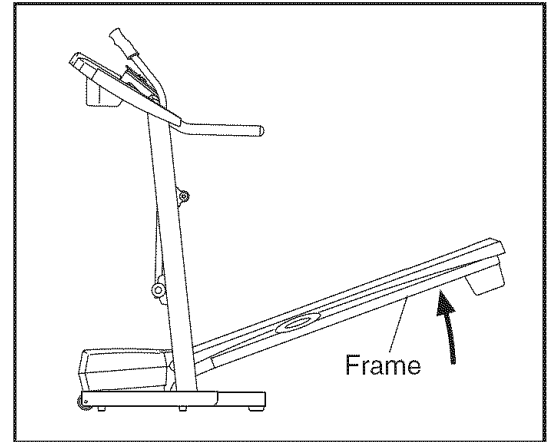

HOW TO MOVE THE TREADMILL

Before moving the treadmill, convert the treadmill to the storage position as described above. **Make sure that the latch pin is fully inserted into the frame.**

1. Hold the upper ends of the handrails, and place one foot against one of the wheels.
2. Tilt the treadmill back until it rolls freely on the wheels. Carefully move the treadmill to the desired location. **To reduce the risk of injury, use extreme caution while moving the treadmill. Do not move the treadmill over an uneven surface.**
3. Place one foot against one of the wheels, and carefully lower the treadmill until it is resting in the storage position.

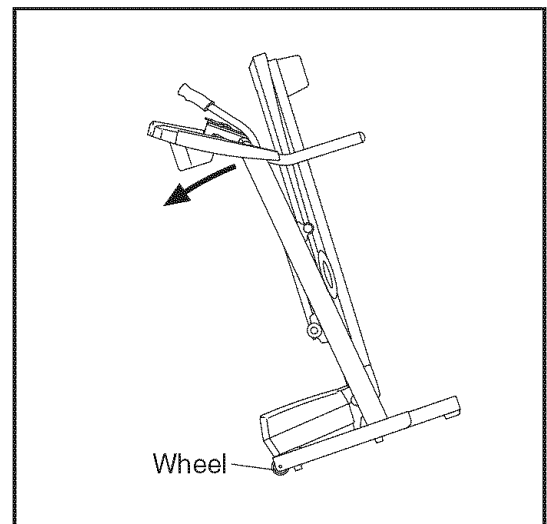

HOW TO LOWER THE TREADMILL FOR USE

1. Hold the treadmill with your right hand as shown. Pull the latch knob to the left and hold it. Pivot the treadmill down until the frame is past the latch pin.

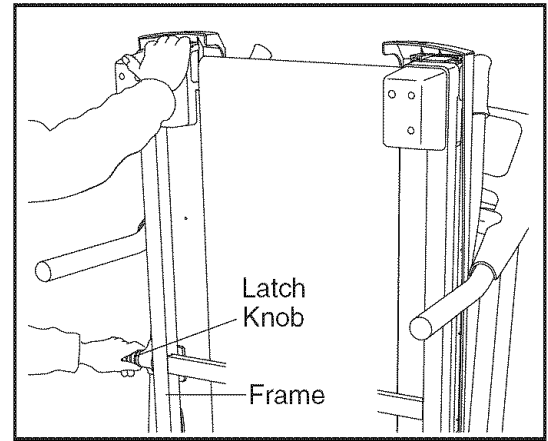

2. **Hold the metal frame firmly with both hands, and lower the frame to the floor. CAUTION: To decrease the possibility of injury, do not lower the frame by gripping only the plastic foot rails. Do not drop the frame to the floor. Make sure to bend your legs and keep your back straight.**

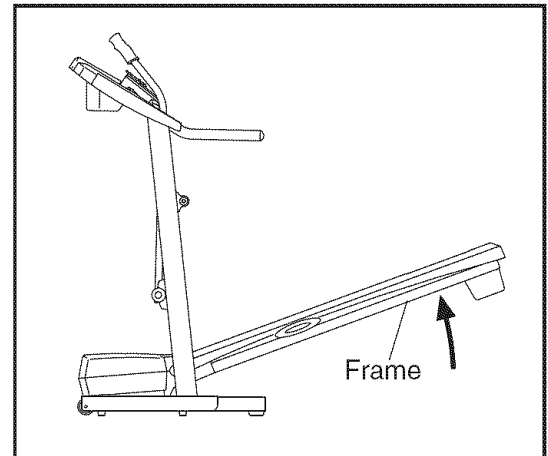

TROUBLESHOOTING

Most treadmill problems can be solved by following the simple steps below. Find the symptom that applies, and follow the steps listed. If further assistance is needed, call toll-free 1-800-4-MY-HOME® (1-800-469-4663).

PROBLEM: The power does not turn on

SOLUTION: a. Make sure that the power cord is plugged into a surge suppressor, and that the surge suppressor is plugged into a properly grounded outlet (see page 10). Use only a single-outlet surge suppressor that meets all of the specifications described on page 10. Important: The treadmill is not compatible with GFCI-equipped outlets.

b. After the power cord has been plugged in, make sure that the key is inserted into the console.

c. Check the reset/off circuit breaker located on the treadmill frame near the power cord. If the switch protrudes as shown, the circuit breaker has tripped. To reset the circuit breaker, wait for five minutes and then press the switch back in.

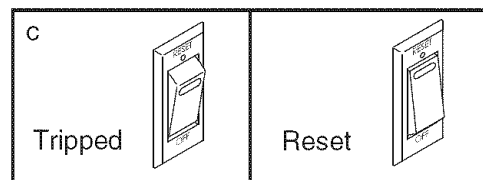

PROBLEM: The power turns off during use

SOLUTION: a. Check the circuit breaker located on the treadmill frame near the power cord (see the drawing above). If the circuit breaker has tripped, wait for five minutes and then press the switch back in.

b. Make sure that the power cord is plugged in. If the power cord is plugged in, unplug it, wait for five minutes, and then plug it back in.

c. Remove the key from the console. Reinsert the key into the console.

d. If the treadmill still will not run, please call toll-free 1-800-4-MY-HOME® (1-800-469-4663).

PROBLEM: The displays of the console do not function properly

SOLUTION: a. Remove the key from the console and **UNPLUG THE POWER CORD**. Remove the Screws (115) from the Hood (1), and carefully pivot the Hood off.

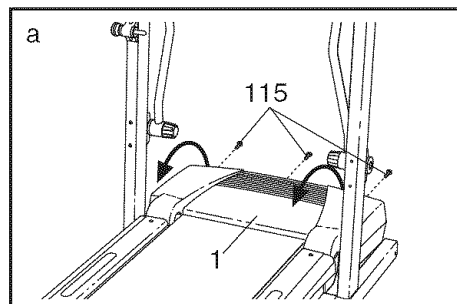

Locate the Reed Switch (10) and the Magnet (18) on the left side of the Pulley (17). Turn the Pulley until the Magnet is aligned with the Reed Switch. **Make sure that the gap between the Magnet and the Reed Switch is about 1/8"**. If necessary, loosen the Screw (58), move the Reed Switch slightly, and then retighten the Screw. Reattach the Hood, and run the treadmill for a few minutes to check for a correct speed reading.

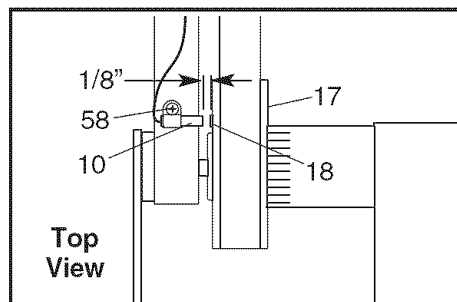

PROBLEM: The walking belt slows when walked on

SOLUTION: a. Use only a single-outlet surge suppressor that meets all of the specifications described on page 10.

b. If the walking belt is overtightened, treadmill performance may decrease and the walking belt may become damaged. Remove the key and **UNPLUG THE POWER CORD**. Using the allen wrench, turn both rear roller bolts counterclockwise, 1/4 of a turn. When the walking belt is properly tightened, you should be able to lift each edge of the walking belt 2 to 3 inches off the walking platform. Be careful to keep the walking belt centered. Then, plug in the power cord, insert the key, and run the treadmill for a few minutes. Repeat until the walking belt is properly tightened.

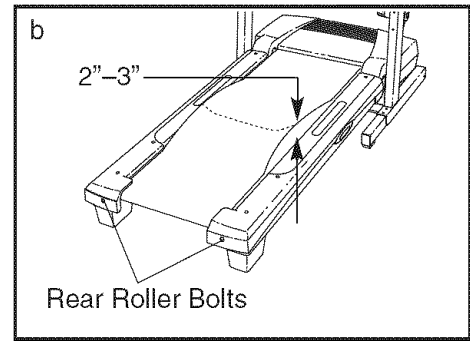

c. If the walking belt still slows when walked on, please call toll-free 1-800-4-MY-HOME® (1-800-469-4663).

PROBLEM: The walking belt is off-center or slips when walked on

SOLUTION: a. If the walking belt is off-center, remove the key and **UNPLUG THE POWER CORD**. **If the walking belt has shifted to the left**, use the allen wrench to turn the left rear roller bolt clockwise 1/2 of a turn; **if the walking belt has shifted to the right**, turn the bolt counterclockwise 1/2 of a turn. Be careful not to overtighten the walking belt. Then, plug in the power cord, insert the key, and run the treadmill for a few minutes. Repeat until the walking belt is centered.

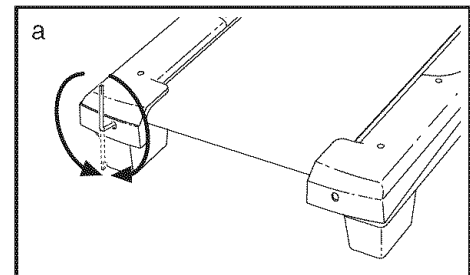

b. If the walking belt slips when walked on, remove the key and **UNPLUG THE POWER CORD**. Using the allen wrench, turn both rear roller bolts clockwise, 1/4 of a turn. When the walking belt is correctly tightened, you should be able to lift each edge of the walking belt 2 to 3 inches off the walking platform. Be careful to keep the walking belt centered. Then, plug in the power cord, insert the key, and carefully walk on the treadmill for a few minutes. Repeat until the walking belt is properly tightened.

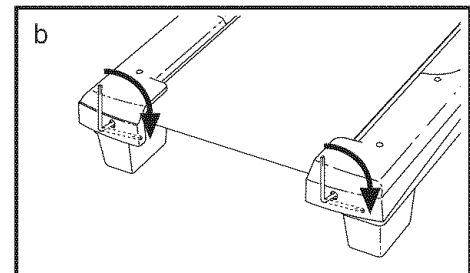

PROBLEM: The upper body arms squeak during use

SOLUTION: a. (Note: Correcting this problem requires a small amount of white marine grease, available at hardware stores.) Turn the Resistance Knob (109) counterclockwise and remove it. Next, remove the Resistance Cone (108) and the Upper Body Arm (24), along with the Resistance Plate (27), Washers (5), Spring Washer (111), Thrust Washers (112), and Thrust Bearing (113). (Note: If the Resistance Sleeve [107] or the Resistance Plate [27] comes out of the Resistance Bracket [105] or the Resistance Cone [108], press it back in.) Apply a **thin layer** of white marine grease to the outer surface of the Resistance Cone (107). Then, reattach all parts in the order shown at the right.

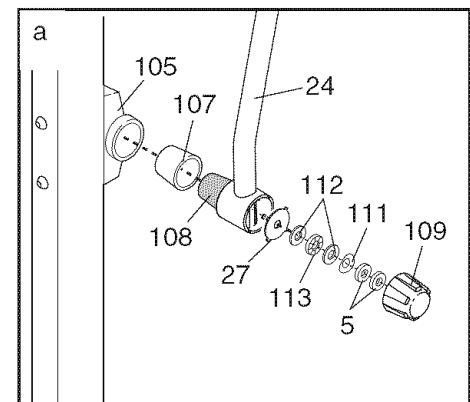

CONDITIONING GUIDELINES

⚠ WARNING: Before beginning this or any exercise program, consult your physician. This is especially important for individuals over the age of 35 or individuals with pre-existing health problems.

The pulse sensor is not a medical device. Various factors, including the user's movement, may affect the accuracy of heart rate readings. The pulse sensor is intended only as an exercise aid in determining heart rate trends in general.

The following guidelines will help you to plan your exercise program. For more detailed exercise information, obtain a reputable book or consult your physician.

EXERCISE INTENSITY

Whether your goal is to burn fat or to strengthen your cardiovascular system, the key to achieving the desired results is to exercise with the proper intensity. The proper intensity level can be found by using your heart rate as a guide. The chart below shows recommended heart rates for fat burning and aerobic exercise.

| | | | | | | | |
|--------------|-----|-----|-----|-----|-----|-----|-----|
| AEROBIC | 165 | 155 | 145 | 140 | 130 | 125 | 115 |
| MAX FAT BURN | 145 | 138 | 130 | 125 | 118 | 110 | 103 |
| FAT BURN | 125 | 120 | 115 | 110 | 105 | 95 | 90 |
| Age | 20 | 30 | 40 | 50 | 60 | 70 | 80 |

To find the proper heart rate for you, first find your age near the bottom of the chart (ages are rounded off to the nearest ten years). Next, find the three numbers above your age. The three numbers define your "training zone." The lower two numbers are recommended heart rates for fat burning, and the higher number is the recommended heart rate for aerobic exercise.

Fat Burning

To burn fat effectively, you must exercise at a relatively low intensity level for a sustained period of time. During the first few minutes of exercise, your body uses easily accessible *carbohydrate calories* for energy. Only after the first few minutes does your body

begin to use stored *fat calories* for energy. If your goal is to burn fat, adjust the speed and incline of the treadmill until your heart rate is near the lowest number in your training zone.

For maximum fat burning, adjust the speed and incline of the treadmill until your heart rate is near the middle number in your training zone.

Aerobic Exercise

If your goal is to strengthen your cardiovascular system, your exercise must be "aerobic." Aerobic exercise is activity that requires large amounts of oxygen for prolonged periods of time. This increases the demand on the heart to pump blood to the muscles, and on the lungs to oxygenate the blood. For aerobic exercise, adjust the speed and incline of the treadmill until your heart rate is near the highest number in your training zone.

WORKOUT GUIDELINES

Each workout should include the following three parts:

A Warm-up—Start each workout with 5 to 10 minutes of stretching and light exercise. A proper warm-up increases your body temperature, heart rate and circulation in preparation for exercise.

Training Zone Exercise—After warming up, increase the intensity of your exercise until your pulse is in your training zone for 20 to 60 minutes. (During the first few weeks of your exercise program, do not keep your pulse in your training zone for longer than 20 minutes.) Breathe regularly and deeply as you exercise—never hold your breath.

A Cool-down—Finish each workout with 5 to 10 minutes of stretching to cool down. This will increase the flexibility of your muscles and will help prevent post-exercise problems.

EXERCISE FREQUENCY

To maintain or improve your condition, complete three workouts each week, with at least one day of rest between workouts. After a few months, you may complete up to five workouts each week if desired. The key to success is to make exercise a regular and enjoyable part of your everyday life.

PART LIST—Model No. 831.29633.0

R1105A

| Key No. | Qty. | Description | Key No. | Qty. | Description | Key No. | Qty. | Description |
|---------|------|-----------------------------|---------|------|---------------------------|---------|------|---------------------------|
| 1 | 1 | Hood | 43 | 1 | Console | 88 | 1 | Console Warning Decal |
| 2 | 9 | 3/4" Screw | 44 | 2 | Rear Roller Plate | 89 | 2 | Cable Tie Clamp |
| 3 | 1 | Motor Belt | 45 | 4 | 3 1/2" Bolt | 90 | 1 | Front Roller Star Washer |
| 4 | 2 | Motor Tension Bolt | 46 | 4 | Extension Leg Nut | 91 | 1 | Sensor Clip |
| 5 | 4 | 3/8" Washer | 47 | 1 | Console Base | 92 | 1 | Ground Screw |
| 6 | 1 | Motor Star Washer | 48 | 6 | 1/2" Screw | 93 | 4 | Extension Leg Bolt |
| 7 | 1 | Flywheel | 49 | 1 | Wire Clamp | 94 | 1 | Allen Wrench |
| 8 | 1 | Drive Motor | 50 | 1 | Key/Clip | 95 | 4 | Handrail Star Washer |
| 9 | 2 | Foot Rail Cover | 51 | 1 | Incline Motor | 96 | 1 | Walking Belt |
| 10 | 1 | Reed Switch | 52 | 2 | Rear Roller Washer | 97 | 1 | Walking Platform |
| 11 | 1 | Latch Warning Decal | 53 | 1 | Incline Motor Bolt, Lower | 98 | 1 | Right Foot Rail |
| 12 | 2 | Frame Spacer | | | | 99 | 4 | U-nut |
| 13 | 9 | Nut | 54 | 2 | Incline Pivot Bolt | 100 | 1 | Rear Roller |
| 14 | 2 | Frame Pivot Bolt | 55 | 2 | Incline Pivot Nut | 101 | 2 | Upper Body Arm Screw |
| 15 | 2 | Platform Screw, Front | 56 | 1 | Motor Controller Wire | 102 | 3 | Incline Motor Bolt, Upper |
| 16 | 2 | Handrail Cap | 57 | 4 | Round Base Pad | 103 | 1 | Motor Mount Bracket |
| 17 | 1 | Front Roller/Pulley | 58 | 21 | 3/4" Tek Screw | 104 | 2 | Resistance Bolt |
| 18 | 1 | Magnet | 59 | 1 | Controller | 105 | 2 | Resistance Bracket |
| 19 | 1 | Motor Pivot Bolt | 60 | 1 | Lift Frame | 106 | 4 | Star Washer |
| 20 | 2 | Motor Bracket Bolt | 61 | 2 | Extension Leg Pad | 107 | 2 | Resistance Sleeve |
| 21 | 2 | Upper Body Arm Endcap | 62 | 2 | Warning Decal | 108 | 2 | Resistance Cone |
| 22 | 3 | Hood Clip | 63 | 2 | Extension Leg | 109 | 2 | Resistance Knob |
| 23 | 3 | Roller Adj. Bolt | 64 | 2 | Wheel Bolt | 110 | 1 | Latch Pin Assembly |
| 24 | 1 | Left Upper Body Arm w/Grip | 65 | 2 | Base Endcap | 111 | 2 | Spring Washer |
| 25 | 1 | Right Upper Body Arm w/Grip | 66 | 2 | Wheel | 112 | 4 | Thrust Washer |
| 26 | 1 | Ground Screw | 67 | 2 | 1/4" Nut | 113 | 2 | Thrust Bearing |
| 27 | 2 | Resistance Plate | 68 | 4 | 8" Cable Tie | 114 | 1 | Power Cord Ground Screw |
| 28 | 2 | Motor Tension Nut | 69 | 1 | Upright Base | 115 | 3 | Belly Pan Screw |
| 29 | 1 | Latch Housing | 70 | 1 | Grommet | 116 | 2 | Platform Washer |
| 30 | 1 | Latch Catch | 71 | 1 | Left Handrail | # | 1 | 4" Blue Wire, 2F |
| 31 | 2 | Left Rear Endcap | 72 | 1 | Right Handrail | # | 1 | 4" Black Wire, M/F |
| 32 | 2 | Platform Screw, Rear | 73 | 6 | Rear Endcap Screw | # | 1 | 8" Green Wire, F/R |
| 33 | 2 | Static Decal | 74 | 1 | Left Foot Rail | # | 1 | 4" Blue Wire, 2F |
| 34 | 1 | Left Grip Plate | 75 | 1 | Silver Ground Screw | # | 1 | 4" Red Wire, M/F |
| 35 | 2 | Roller Bracket Screw | 76 | 2 | Foam Grip | # | 1 | User's Manual |
| 36 | 1 | Right Grip Plate | 77 | 4 | Belly Pan Screw | | | |
| 37 | 4 | Handrail Bolt | 78 | 1 | Right Rear Endcap | | | |
| 38 | 6 | Washer | 79 | 1 | Power Cord Assembly | | | |
| 39 | 4 | 1" Tek Screw | 80 | 2 | Rear Roller Bracket | | | |
| 40 | 1 | Ground Wire | 81 | 1 | Belly Pan | | | |
| 41 | 2 | Rear Roller Star Washer | 82 | 2 | Belt Guide | | | |
| 42 | 1 | Upright Wire | 83 | 4 | Belt Guide Screw | | | |
| | | | 84 | 4 | Isolator Fastener | | | |
| | | | 85 | 2 | Isolator Cushion | | | |
| | | | 86 | 1 | Frame | | | |
| | | | 87 | 4 | Releasable Tie | | | |

#These parts are not illustrated

If a part is missing, call toll-free 1-888-533-1333.

EXPLODED DRAWING—Model No. 831.29633.0

R1105A

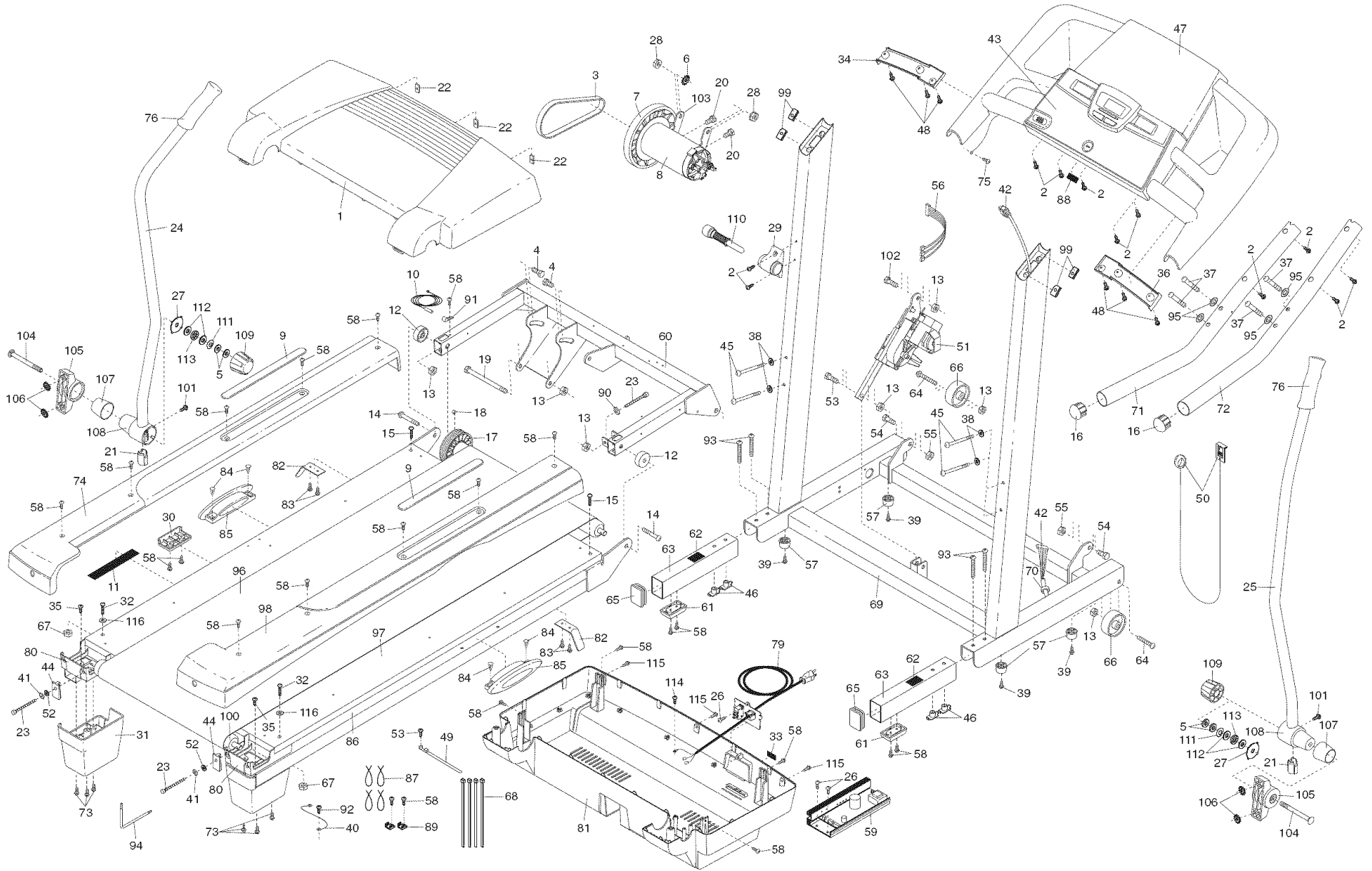

Get it fixed, at your home or ours!

Your Home

For repair – **in your home** – of **all** major brand appliances, lawn and garden equipment, or heating and cooling systems, **no matter who made it, no matter who sold it!**

For the replacement parts, accessories, and user's manuals that you need to do-it-yourself.

For Sears professional installation of home appliances and items like garage door openers and water heaters.

1-800-4-MY-HOME®

(1-800-469-4663)

www.sears.com

Anytime, day or night

(U.S.A. and Canada)

www.sears.ca

Our Home

For repair of carry-in products like vacuums, lawn equipment, and electronics, call or go on-line for the location of your nearest **Sears Parts and Repair Center.**

1-800-488-1222 Anytime, day or night (U.S.A. only)

www.sears.com

To purchase a protection agreement (U.S.A.) or maintenance agreement (Canada) on a product serviced by Sears:

1-800-827-6655 (U.S.A.)

1-800-361-6665 (Canada)

Para pedir servicio de reparación a domicilio, y para ordenar piezas:

1-888-SU-HOGARSM (1-888-784-6427)

SEARS

® Registered Trademark / ™ Trademark / SM Service Mark of Sears, Roebuck and Co.
® Marca Registrada / ™ Marca de Fábrica / SM Marca de Servicio de Sears, Roebuck and Co.

FULL 90 DAY WARRANTY

For 90 days from the date of purchase, if failure occurs due to defect in material or workmanship in this Sears Treadmill Exerciser, contact the nearest Sears Service Center throughout the United States and Sears will repair or replace the Treadmill Exerciser, free of charge. The drive motor is warranted for three (3) years from the date of purchase.

This warranty does not apply when the Treadmill Exerciser is used commercially or for rental purposes.

This warranty gives you specific legal rights, and you may also have other rights which vary from state to state.

Sears, Roebuck and Co., Dept. 817WA, Hoffman Estates, IL 60179