

**FOR MODEL :**

**RST5.6**



**HORIZON**  
FITNESS

# **TREADMILL ASSEMBLY & USER'S GUIDE**

# INTRODUCTION

**CONGRATULATIONS** and **THANK YOU** for your purchase of this Horizon Fitness treadmill!

Whether your goal is to win races or simply enjoy a fuller, healthier lifestyle, a Horizon Fitness treadmill can help you attain it – adding club-quality performance to your at-home workouts, with the ergonomics and innovative features you need to get stronger and healthier, faster. Because we're committed to designing fitness equipment from the inside out, we use only the highest quality components. It's a commitment we back with one of the strongest frame-to-motor warranty packages in the industry.

You want exercise equipment that offers the most comfort, the best reliability and the highest quality in its class.

**Horizon Fitness delivers.**

## TABLE OF CONTENTS

<i>Important Precautions</i>	<i>4</i>
<i>Assembly</i>	<i>6</i>
<i>Before You Begin</i>	<i>12</i>
<i>Treadmill Operation</i>	<i>15</i>
<i>Conditioning Guidelines</i>	<i>22</i>
<i>Troubleshooting &amp; Maintenance</i>	<i>28</i>
<i>Limited Warranty</i>	<i>31</i>
<b>CONTACT INFORMATION</b>	<i>Back Cover</i>

## IMPORTANT PRECAUTIONS

### SAVE THESE INSTRUCTIONS

Read all instructions before using this treadmill. When using an electrical product, basic precautions should always be followed, including the following: Read all instructions before using this treadmill. It is the responsibility of the owner to ensure that all users of this treadmill are adequately informed of all warnings and precautions. If you have any questions after reading this manual, contact Sears at the number listed on the back cover of this manual.



Connect this exercise product to a properly grounded outlet only. See grounding instructions.

### GROUNDING INSTRUCTIONS

This product must be grounded. If a treadmill should malfunction or breakdown, grounding provides a path of least resistance for electrical current to reduce the risk of electrical shock. This product is equipped with a cord having an equipment-grounding conductor and a grounding plug. The plug must be plugged into an appropriate outlet that is properly installed and grounded in accordance with local codes and ordinances.



Improper connection of the equipment-grounding conductor can result in a risk of electric shock. Check with a qualified electrician or serviceman if you are in doubt as to whether the product is properly grounded. Do not modify the plug provided with the product. If it will not fit the outlet, have a proper outlet installed by a qualified electrician.

This product is for use on a nominal 110-volt circuit and has a grounding plug that looks like the illustration to the right. This product must be used on a dedicated circuit. To determine if you are on a dedicated circuit, shut off the power to that circuit and observe if any other devices lose power. If so, move devices to a different circuit. **Note:** There are usually multiple outlets on one circuit. It is recommended that the treadmill be used with a 20 amp circuit for optimal performance.

3-Pole Grounded Outlet

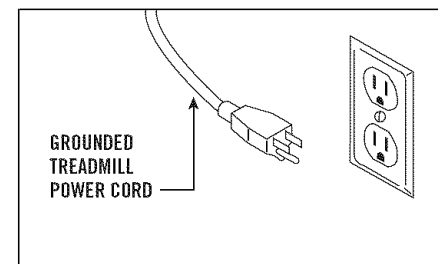

To reduce the risk of burns, fire, electrical shock or injury to persons:

- Never use the treadmill before securing the safety tether clip to your clothing.
- If you experience any kind of pain, including but not limited to chest pains, nausea, dizziness, or shortness of breath, stop exercising immediately and consult your physician before continuing.
- Do not wear clothes that might catch on any part of the treadmill.
- Always wear athletic shoes while using this equipment.
- Do not jump on the treadmill.
- Keep power cord away from heated surfaces.
- Do not insert or drop any object into any opening.
- Unplug treadmill before moving or cleaning it. To clean, wipe surfaces down with soap and slightly damp cloth only; never use solvents. (See MAINTENANCE)
- At no time should more than one person be on treadmill while in operation.
- The treadmill should not be used by persons weighing more than 275 pounds. Failure to comply will void the warranty.
- The treadmill is intended for in-home use only. Do not use this treadmill in any commercial, rental, school or institutional setting. Failure to comply will void the warranty.
- Do not use treadmill in any location that is not temperature controlled, such as but not limited to garages, porches, pool rooms, bathrooms, car ports or outdoors. Failure to comply may void the warranty.
- Use the treadmill only as described in this manual.

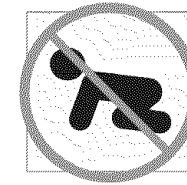

At NO time should pets or children under the age of 12 be closer to the treadmill than 10 feet.  
At NO time should children under the age of 12 use the treadmill.  
Children over the age of 12 should not use the treadmill without adult supervision.

### OTHER SAFETY TIPS FOR YOUR TREADMILL



#### OPERATION

To reduce the risk of damaging important components on your treadmill, it is strongly recommended that your treadmill is plugged into a dedicated 20 amp circuit, without the use of an additional extension cord and/or power strip. Failure to comply may void the warranty.

**IMPORTANT:** The treadmill is not compatible with GFCI-equipped outlets.

It is essential that your treadmill is used only indoors, in a climate controlled room. If your treadmill has been exposed to colder temperatures or high moisture climates, it is strongly recommended that the treadmill is warmed up to room temperature before first time use. Failure to do so may cause premature electronic failure.

# ASSEMBLY

## IMPORTANT: READ THESE SAFETY INSTRUCTIONS BEFORE USE!



During the assembly process of the treadmill there are several areas that special attention must be paid. It is very important to follow the assembly instructions correctly and to make sure all parts are firmly tightened. If the assembly instructions are not followed correctly, the treadmill could have frame parts that are not tightened and will seem loose and may cause irritating noises. There should be no side-to-side play in the console masts or any forward and back play in the console assembly or handlebars. If there is any play in these areas, the treadmill has not been properly assembled. To prevent damage to the treadmill, the assembly instructions must be reviewed and corrective actions should be taken.

## UNPACKING

Place the treadmill carton on a level flat surface. It is recommended that you place a protective covering on your floor. Take CAUTION when handling and transporting this unit. Never open box when it is on its side. Once the banding straps have been removed, do not lift or transport this unit unless it is fully assembled and in the upright folded position, with the lock latch secure. Unpack the unit where it will be used. Never grab hold of any portion of the incline frame and attempt to lift or move the treadmill. FAILURE TO FOLLOW THESE INSTRUCTIONS COULD RESULT IN INJURY!

Before proceeding, find your treadmill's serial number and model name located under the deck on the frame crossbar and enter it in the space provided below.

### ENTER YOUR SERIAL NUMBER AND MODEL NAME IN THE BOXES BELOW:

SERIAL NUMBER:

MODEL NAME:

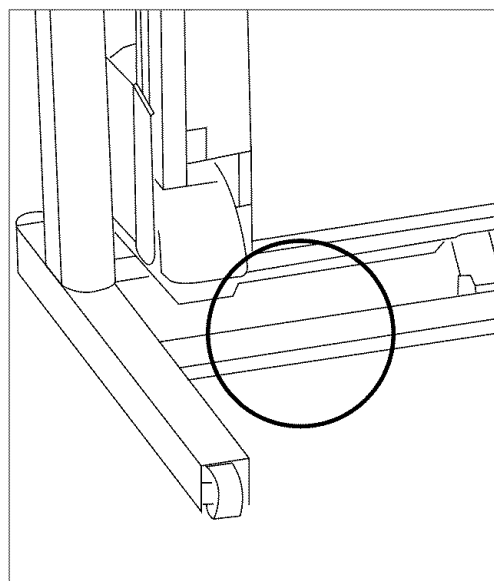

\* Refer to the SERIAL NUMBER and MODEL NAME when calling for service.

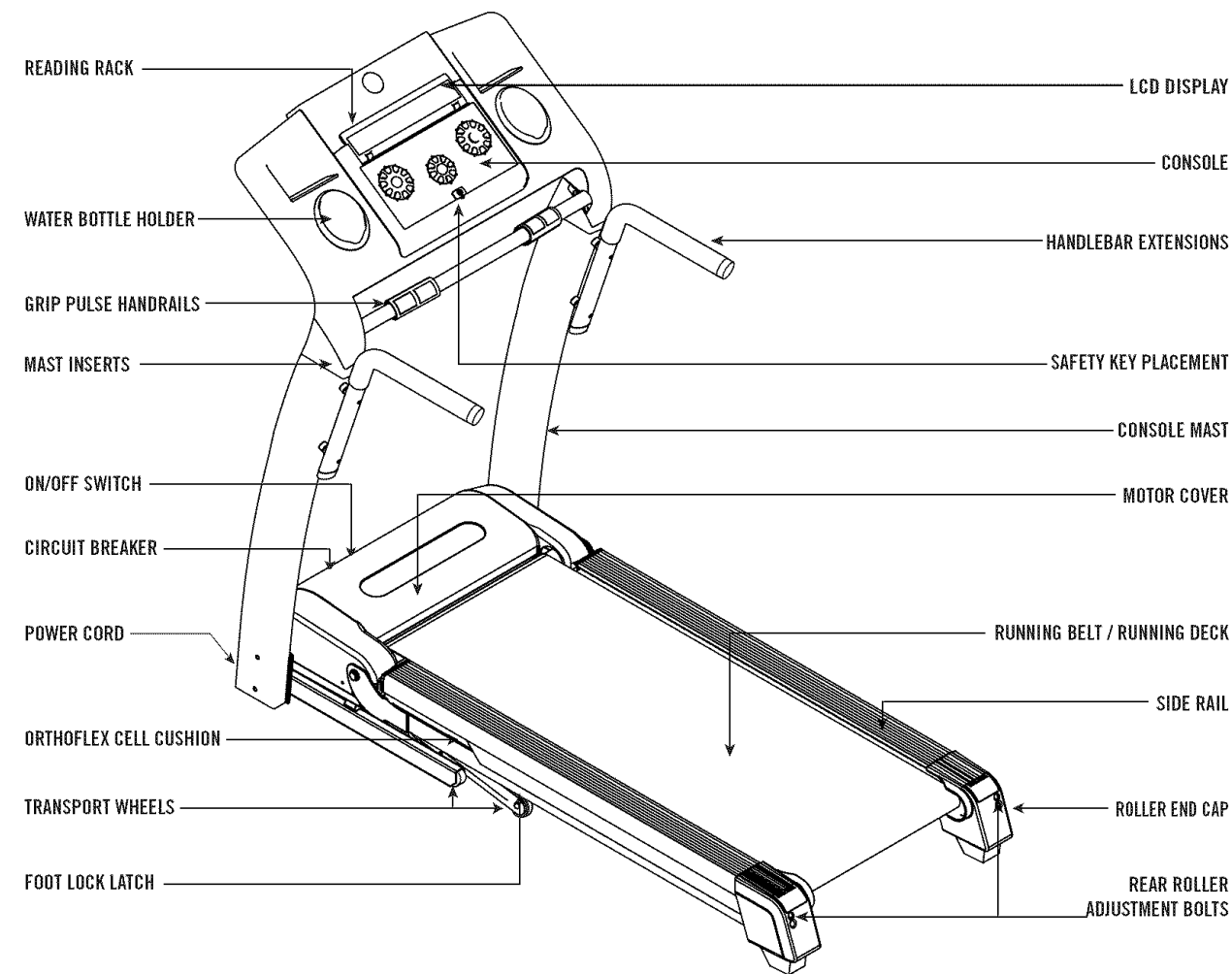

## TOOLS INCLUDED

- 5mm Allen Wrench
- 6mm T-Wrench
- Screwdriver

## PARTS INCLUDED

- 1 Safety Key
- 1 Console Assembly (located under treadmill deck)
- 1 Power Cord
- 3 Hardware Bags
- 2 Roller End Caps
- 2 Console Masts

If you have questions or if there are any missing parts, contact 1-800-4-MY-HOME®. Further contact information is located on the back cover of this manual.

For a complete exploded diagram, see Quick Start and Parts Guide (included in the owner's manual bag).

## PRE-ASSEMBLY

Disassemble box and remove the cardboard packaging that is not beneath the treadmill. Do not attempt to lift the treadmill at this time. Remove plastic wrap from console masts.

**\*NOTE:** During each assembly step, ensure that ALL nuts and bolts are in place and partially threaded in before completely tightening any ONE bolt. **NOTE:** A light application of grease may aid in the installation of hardware. Any grease, such as lithium bike grease is recommended.

## ASSEMBLY STEP 1

### HARDWARE BAG 1 CONTENTS:

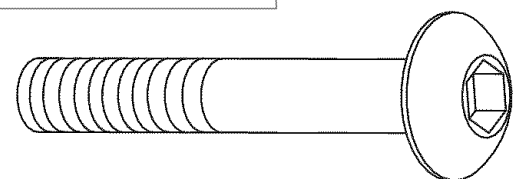

**BOLT (A)**  
55 mm  
Qty: 4

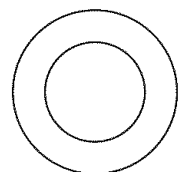

**FLAT WASHER (B)**  
Qty: 4

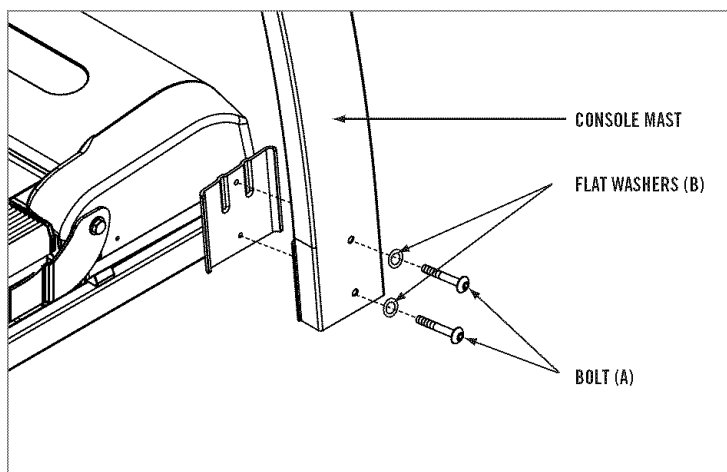
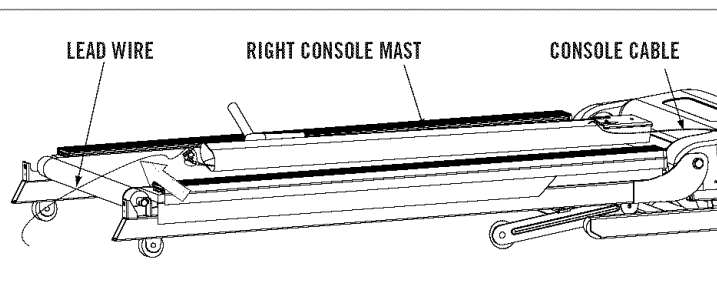

- Open **HARDWARE BAG 1**.
- Pull **LEAD WIRE** through **RIGHT CONSOLE MAST** to drag upward.
- Place **RIGHT CONSOLE MAST** into upright position using 2 **BOLTS (A)** and 2 **FLAT WASHERS (B)**, then tighten. Be sure to hold the **CONSOLE MAST** firmly, as it will not stay in the upright position on its own.  
**\*NOTE:** Do not pinch **CONSOLE CABLE** when placing the mast onto the main frame.
- Repeat on the left side.  
**\*NOTE:** There is no wire in the **LEFT CONSOLE MAST**.

## ASSEMBLY STEP 2

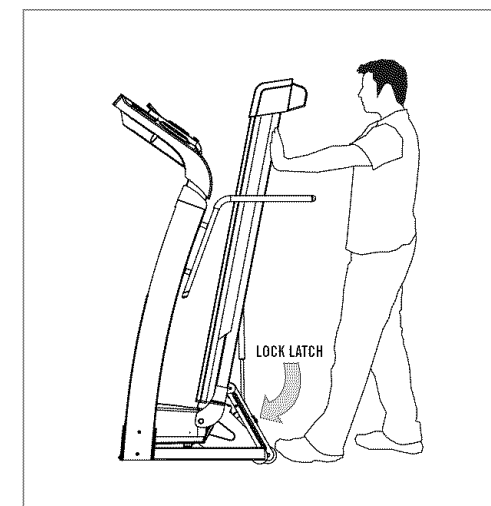
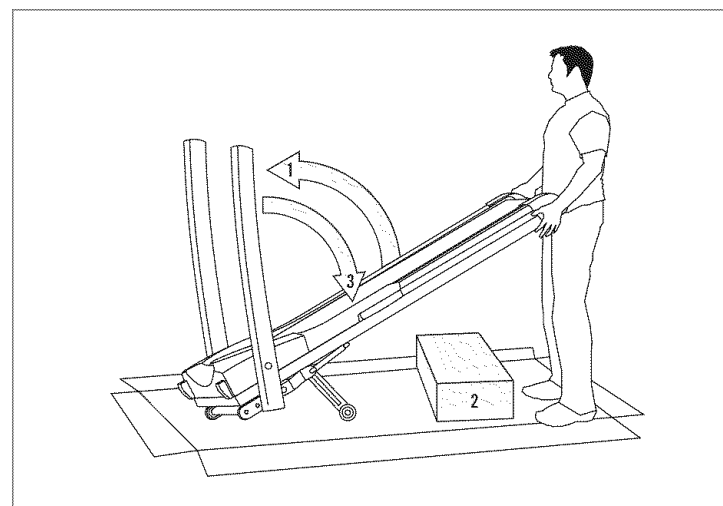

**NOTE:** There is no hardware bag for this step.

- Lift the **RUNNING DECK** until **LOCK LATCH** on side of treadmill is fully engaged.
- Remove **CONSOLE** from box and place out of the way.
- Lower the treadmill **RUNNING DECK** from the folded position by stepping on **LOCK LATCH** on the bottom left side of the deck.

## ASSEMBLY STEP 3

### HARDWARE BAG 3 CONTENTS:

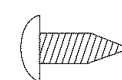

**SCREW (C)**  
12 mm  
Qty: 2

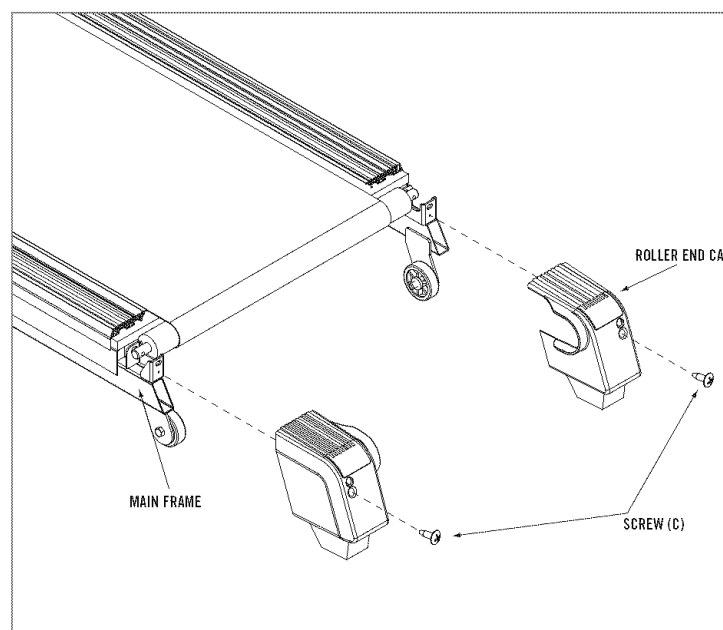

- Open **HARDWARE BAG 3**.
- Slide left **ROLLER END CAP** onto **MAIN FRAME** and attach with **SCREW (C)**.
- Repeat on other side.

## ASSEMBLY STEP 4

## HARDWARE BAG 4 CONTENTS:

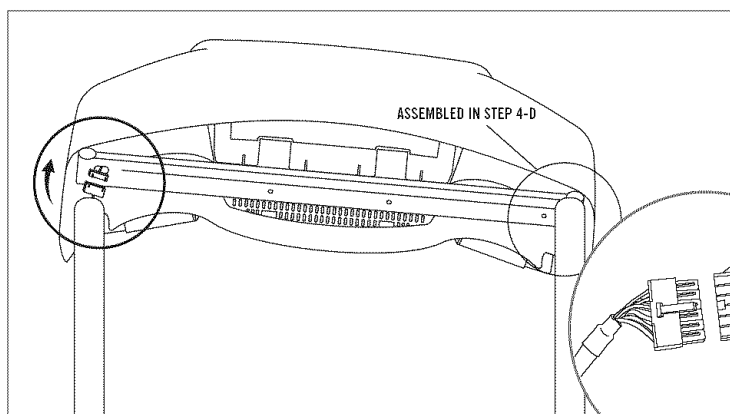
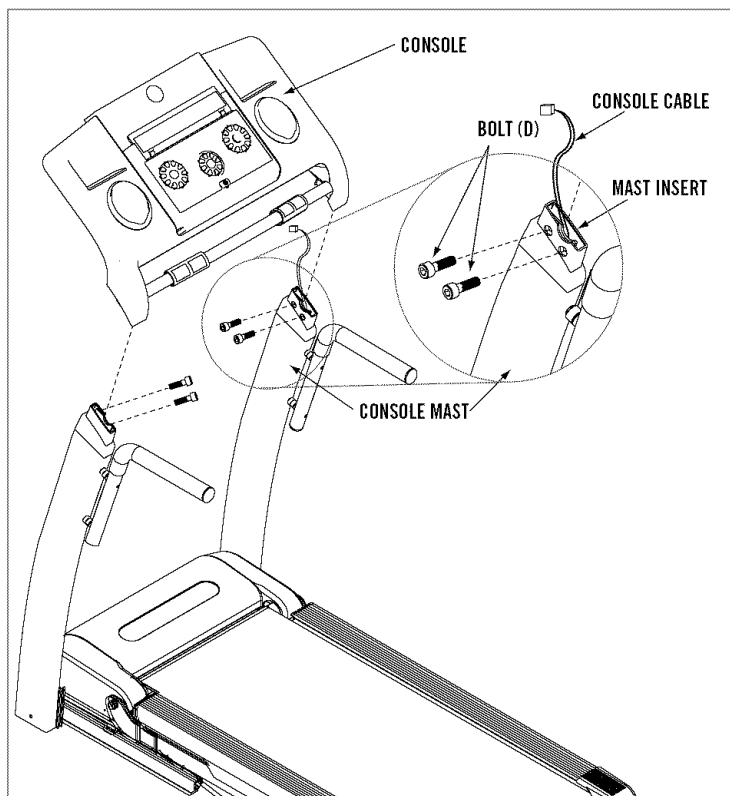
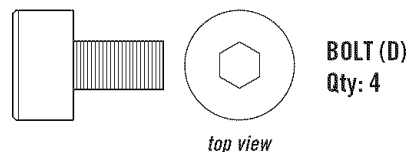

A) Open **HARDWARE BAG 4**.

B) Place the **CONSOLE** on **CONSOLE MASTS**. Slide the brackets that are underneath the **CONSOLE** onto the brackets in the top of the **CONSOLE MASTS**. The **CONSOLE** brackets fit inside the **CONSOLE MAST** brackets.

C) Place 2 **BOLTS (D)** into side of left **CONSOLE MAST** and lightly tighten.

D) Gently lift right side of the **CONSOLE** to connect the **CONSOLE CABLE**. Carefully tuck wires in mast to avoid damage. **\*NOTE:** Do not pinch console cable. Be sure the console cable prongs are aligned and the ends are tightly seated into each other.

E) Repeat step D above to secure the console to the **RIGHT CONSOLE MAST**.

F) Tighten all bolts completely.\*

**\* NOTE:** Be careful not to pinch any wires while assembling the masts.

YOU'RE FINISHED!

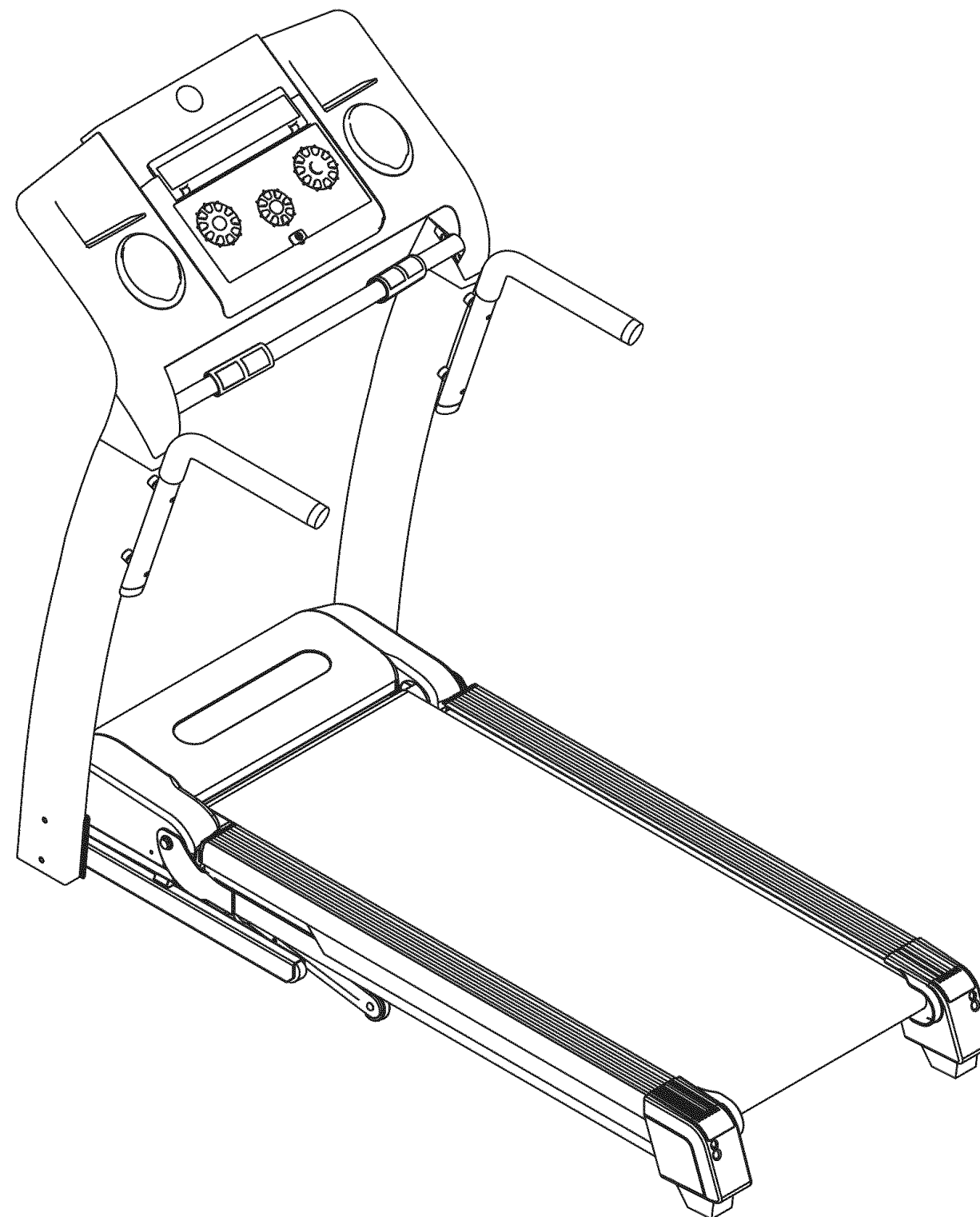

## BEFORE YOU BEGIN

**CONGRATULATIONS!** on choosing your treadmill. You've taken an important step in developing and sustaining an exercise program! Your treadmill is a tremendously effective tool for achieving your personal fitness goals. Regular use of your treadmill can improve the quality of your life in so many ways.

HERE ARE JUST A FEW OF THE HEALTH BENEFITS OF EXERCISE:

- Weight Loss
- A Healthier Heart
- Improved Muscle Tone
- Increased Daily Energy Levels

The key to reaping these benefits is to develop an exercise habit. Your new treadmill will help you eliminate obstacles that prevent you from exercising. Inclement weather and darkness won't interfere with your workout when you use your treadmill in the comfort of your home. This guide provides you with basic information for using and enjoying your new machine.

### LOCATION OF THE TREADMILL

Place the treadmill on a level surface. There should be 6 feet of clearance behind the treadmill, 3 feet on each side and one foot in front for folding and the power cord. Do not place the treadmill in any area that will block any vent or air openings. The treadmill should not be located in a garage, covered patio, near water or outdoors.

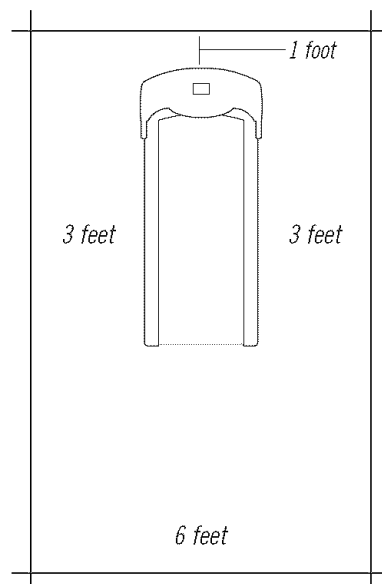

### DO NOT STAND ON THE BELT

While you are preparing to use the treadmill, do not stand on the belt. Place your feet on the side rails before starting the treadmill. Start walking on the belt only after the belt has begun to move. Never start the treadmill at a fast running speed and attempt to jump on!

### SAFETY KEY

Your treadmill will not start unless the safety key is placed in position. Attach the clip end securely to your clothing. This safety key is designed to cut the power to the treadmill if you should fall. Check the operation of the safety key every 2 weeks.



**NEVER USE THE TREADMILL WITHOUT SECURING THE SAFETY KEY CLIP TO YOUR CLOTHING. PULL ON THE SAFETY KEY CLIP FIRST TO MAKE SURE IT WILL NOT COME OFF YOUR CLOTHING.**

### PROPER USAGE

Your treadmill is capable of reaching high speeds. Always start off using a slower speed and adjust the speed in small increments to reach a higher speed level. Never leave the treadmill unattended while it is running. When not in use, remove the safety key, turn the on/off switch to off and unplug the power cord. Make sure to follow the MAINTENANCE schedule located on page 31. in this manual. Keep your body and head facing forward. Do not attempt to turn around or look backwards while the treadmill is running. Stop your workout immediately if you feel pain, faint, dizzy or are short of breath.



**Do not operate the treadmill if the power cord or plug is damaged. If the treadmill appears to not be working properly, do not use the treadmill.**

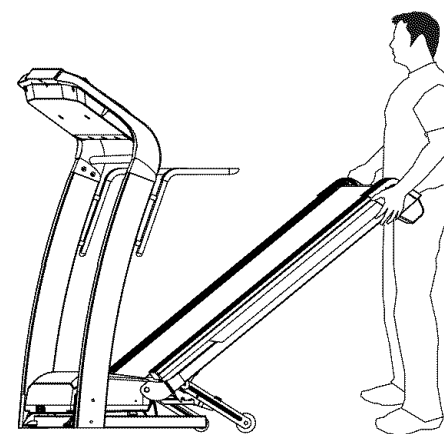

### FOLDING

Firmly grasp the back end of the treadmill. Carefully lift the end of the treadmill deck into the upright position until the foot lock latch engages and securely locks the deck into position. Make sure the deck is securely latched before letting go.



### UNFOLDING

To unfold, firmly grasp the back end of the treadmill. Gently press down on the foot lock latch with your foot until the lock latch disengages. Carefully lower the deck to the ground.

**NOTE:** The foot-lock latch is located at the bottom left side of the deck.

### MOVING

Your treadmill has a pair of transport wheels built into the frame. To move, make sure the treadmill is folded and securely latched. Then firmly grasp the handlebars, tilt the treadmill back and roll.



**Our Treadmills are heavy; use care and additional help if necessary when moving. Do not attempt to move or transport treadmill unless it is in the upright, folded position with the lock latch secured. Failure to follow these instructions could result in injury.**

## TENSIONING THE RUNNING BELT

The running belt has been properly adjusted at the factory before it was shipped. At times the belt can move off-center during shipment.

**CAUTION:** Running belt should NOT be moving during tensioning. Over-tightening the running belt can cause excessive wear on the treadmill as well as its components. Never over-tighten the belt.

If you can feel a slipping sensation when running on the treadmill, the running belt must be tightened. In most cases, the belt has stretched from use, causing the belt to slip. This is a normal and common adjustment. To eliminate this slipping, **TURN THE TREADMILL OFF** and tension **BOTH THE REAR ROLLER BOLTS** using the supplied allen wrench, turning them 1/4 TURN to the right as shown. Turn the treadmill on and check for slipping. Repeat if necessary, but **NEVER TURN** the roller bolts more than 1/4 turn at a time. Belt is properly tensioned when the slipping sensation is gone.

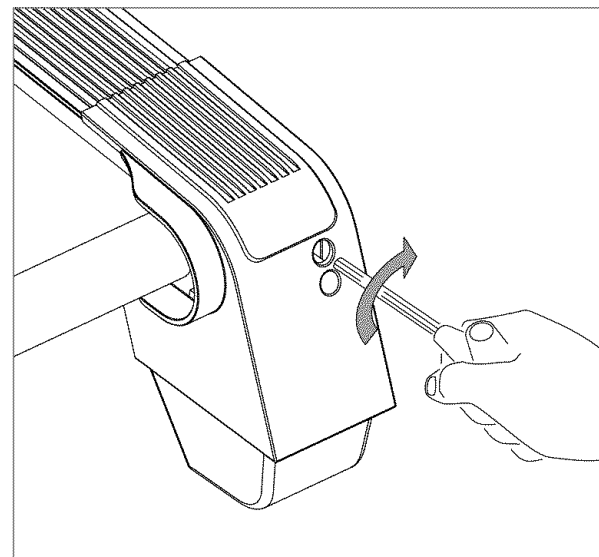

## CENTERING THE RUNNING BELT

The running belt has been properly adjusted at the factory before it was shipped. At times the belt can move off-center during shipment. Before operating the treadmill, make sure the belt is centered and remains centered to maintain smooth operation.

**CAUTION:** Do not run belt faster than 1/2 mph while centering. Keep fingers, hair and clothing away from belt at all times.

**If the running belt is too far to the right side:** With the treadmill running at 1/2 mph, turn the right adjustment bolt clockwise 1/4 TURN at a time (using the supplied allen wrench). Check the belt alignment. Allow belt to run a full cycle to gauge if more adjustment is needed. Repeat if necessary, until the belt remains centered during use.

**If the running belt is too far to the left side:** With the treadmill running at 1/2 mph, turn the right adjustment bolt counter-clockwise 1/4 TURN at a time (using the supplied allen wrench). Check the belt alignment. Allow belt to run a full cycle to gauge if more adjustment is needed. Repeat if necessary, until the belt remains centered during use.

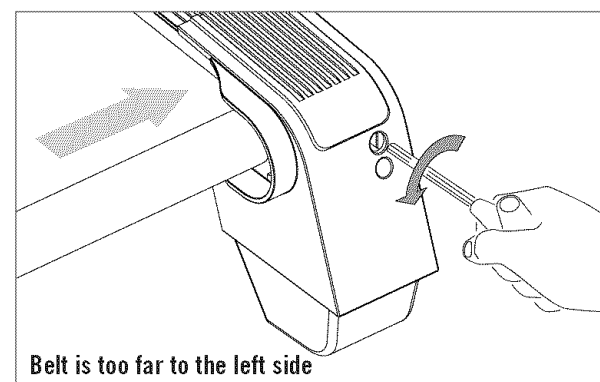
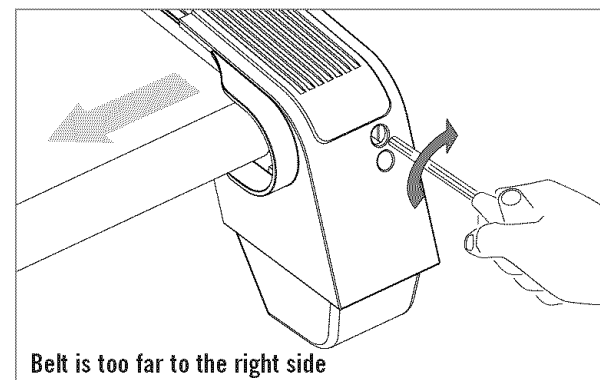

## TREADMILL OPERATION

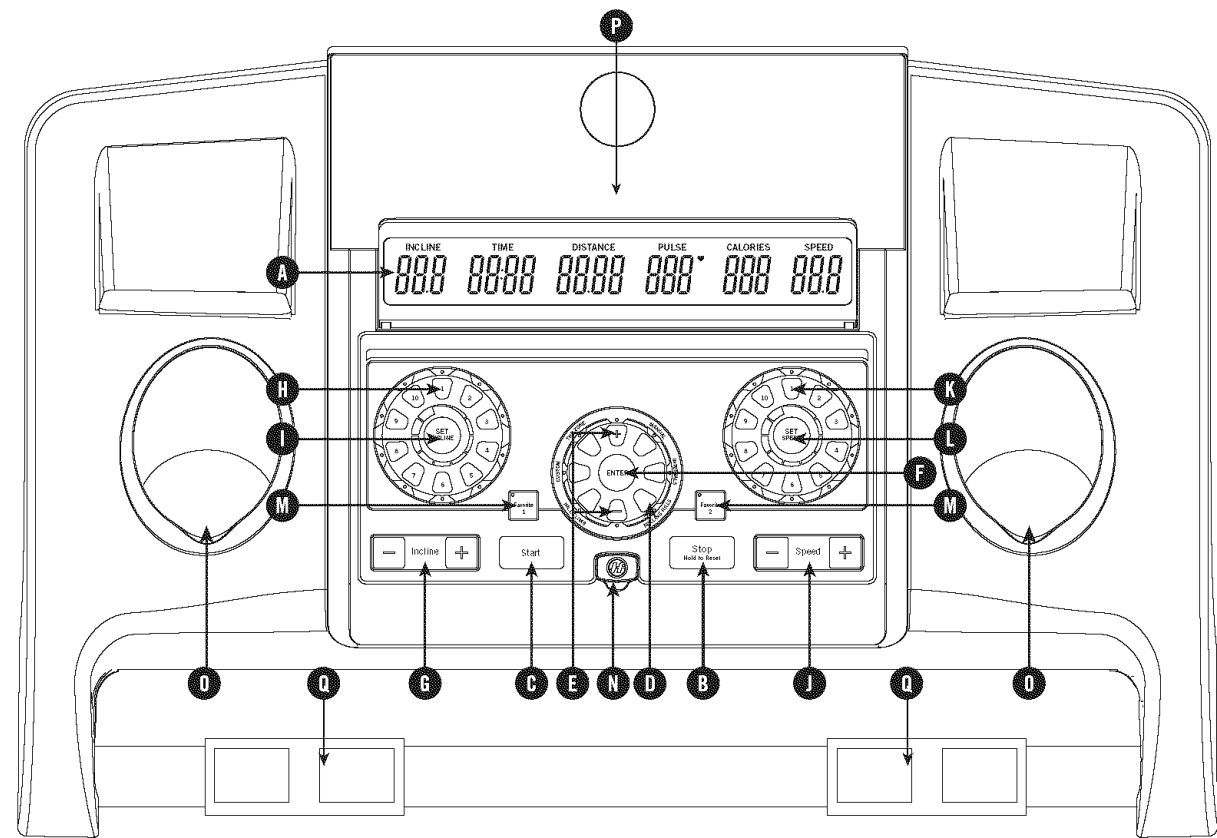

- A) **ADJUSTABLE MONITOR DISPLAY:** Incline, Time, Distance, Pulse, Calories, and Speed.
- B) **STOP:** Press to pause/end your workout. Hold for 3 seconds to reset the treadmill.
- C) **START:** Simply press to begin exercising.
- D) **PROGRAM KEYS:** Used to select your program.
- E) **+/- KEYS:** Used to adjust program settings.
- F) **ENTER:** Used to confirm settings.
- G) **INCLINE ARROW KEYS:** Press to adjust incline (0.5% increments).
- H) **QUICK INCLINE KEYS:** Press to reach desired incline more quickly. Select before pressing **SET INCLINE** key.
- I) **SET INCLINE KEY:** Used to confirm incline change. Press after selecting **INCLINE** with **QUICK INCLINE** keys.
- J) **SPEED ARROW KEYS:** Press to adjust speed (0.1 MPH increments).
- K) **QUICK SPEED KEYS:** Press to reach desired speed more quickly. Select before pressing **SET SPEED** key.
- L) **SET SPEED KEY:** Used to confirm speed change. Press after selecting **SPEED** with **QUICK SPEED** keys.
- M) **USER FAVORITE KEYS:** Retains a user's favorite program settings in memory.
- N) **SAFETY KEY POSITION:** Enables treadmill operation when safety key is in place.
- O) **WATER BOTTLE / CD / MP3 HOLDER:** Holds personal workout equipment.
- P) **READING RACK:** Holds reading material.
- Q) **HEART RATE CONTACT GRIP:** Monitors heart rate from your palms.



## ADJUSTABLE MONITOR DISPLAY

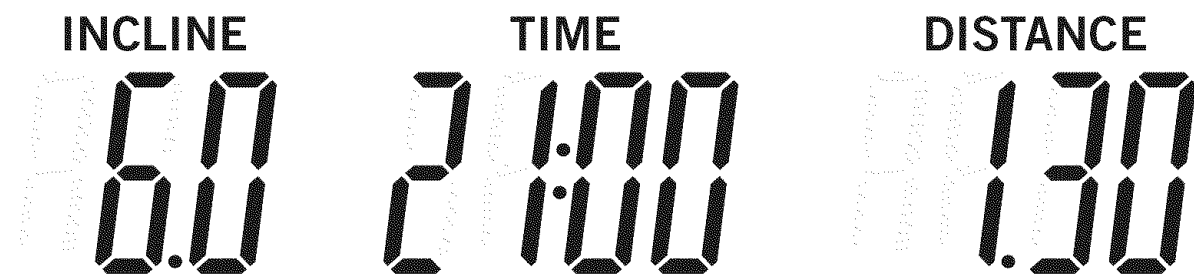

**INCLINE** • Shown as Percent. Indicates the incline of the treadmill deck surface.

**TIME** • Shown as Minutes:Seconds. Indicates the time remaining or the time elapsed in your workout.

**DISTANCE** • Shown as Miles. Indicates distance traveled during your workout.

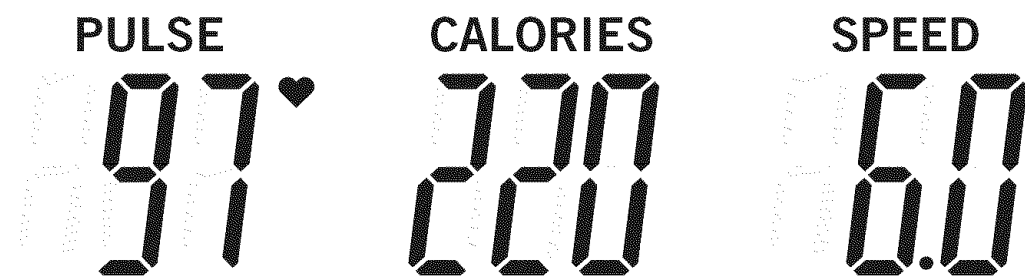

**PULSE** • Shown as Beats Per Minute. Indicates your heart rate (displayed when contact is made with both pulse grips).

**CALORIES** • Indicates total calories burned during your workout.

**SPEED** • Shown as MPH. Indicates the speed of the treadmill belt.

## HEART RATE

### PULSE GRIPS

Place the palm of your hands directly on the grip pulse handlebars. Both hands must grip the bars for your heart rate to register. It takes 5 consecutive heart beats (15-20 seconds) for your heart rate to register. When gripping the pulse handlebars, do not grip tightly. Holding the grips tightly may elevate your blood pressure. Keep a loose, cupping hold. You may experience an erratic readout if consistently holding the grip pulse handlebars. Make sure to clean the pulse sensors to ensure proper contact can be maintained.

## GETTING STARTED / SELECTING A PROGRAM

- 1) Check to make sure nothing is on the treadmill and that nothing will hinder the movement of the treadmill.
- 2) Plug in the power cord and turn the treadmill ON.
- 3) Stand on the side rails of the treadmill.
- 4) Attach the safety key clip to part of your clothing.
- 5) Insert the safety key into the safety key slot located on the console.
- 6) You have two options to start your workout:

### A) QUICK START UP

Simply press the **START** key to begin working out. OR...

### B) SELECT A PROGRAM

Select a program using the **PROGRAM KEYS**.  
Once a program has been chosen, press **ENTER**.

### SELECT A LEVEL

Select a program level using the **+/- KEYS**.  
Once a program level has been chosen, press **ENTER**.

### SET TIME

Set time using the **+/- KEYS** or use the default time.  
Once time has been set, press **START**.

Note: If the **MANUAL (P1)** program is selected, set **TIME**, **INCLINE**, and **SPEED** using the **+/- KEYS**. Press **ENTER** to confirm each selection then press **START**. For more information regarding the custom program or THR Zone program, please see the "PROGRAM INFORMATION" section.

### FINISHING YOUR WORKOUT

When your workout is complete, the **ADJUSTABLE MONITOR DISPLAY** will flash and beep. Your workout information will be displayed on the console for 30 seconds and then reset.

### CLEAR CURRENT SELECTION

To clear the current program selection or screen, hold the **STOP** button for 4-5 seconds.

## PROGRAM INFORMATION

### PROGRAM: MANUAL (P1)

Allows 'On The Fly' manual **SPEED** and **INCLINE** changes. Time-based goal.

### PROGRAM: INTERVALS (P2)

Walk or run a series of alternating **SPEED** levels. Time-based goal with 10 difficulty levels to choose from.

#### INTERVALS PROGRAM SEGMENTS

Time	WARM-UP		1	2	3	4	SEGMENTS ARE REPEATED UNTIL SELECTED TIME IS REACHED	COOL-DOWN	
	2:00	2:00	1:30	:30	1:30	:30		2:00	2:00
Level 1	1.0	1.5	2.0	4.0	2.0	4.0		1.5	1.0
Level 2	1.0	1.5	2.0	4.5	2.0	4.5		1.5	1.0
Level 3	1.3	1.9	2.5	5.0	2.5	5.0		1.9	1.3
Level 4	1.3	1.9	2.5	5.5	2.5	5.5		1.9	1.3
Level 5	1.5	2.3	3.0	6.0	3.0	6.0		2.3	1.5
Level 6	1.5	2.3	3.0	6.5	3.0	6.5		2.3	1.5
Level 7	1.8	2.6	3.5	7.0	3.5	7.0		2.6	1.8
Level 8	1.8	2.6	3.5	7.5	3.5	7.5		2.6	1.8
Level 9	2.0	3.0	4.0	8.0	4.0	8.0		3.0	2.0
Level 10	2.0	3.0	4.0	8.5	4.0	8.5		3.0	2.0

(WARM-UP and COOL-DOWN last 4:00 minutes each and are included in program times. Units are MPH.)

### PROGRAM: ROLLING HILLS (P3)

Motivates with different combinations of **SPEED**. Time-based goal with 10 difficulty levels to choose from.

#### ROLLING HILLS PROGRAM SEGMENTS

TIME	WARM-UP		1	2	3	4	5	6	7	8	SEGMENTS ARE REPEATED UNTIL SELECTED TIME IS REACHED	COOL-DOWN	
	2:00	2:00	:30	:30	:30	:30	:30	:30	:30	:30		2:00	2:00
Level 1	1.0	1.5	2.0	2.5	3.0	3.5	4.0	3.5	3.0	2.5		2.3	1.5
Level 2	1.3	1.9	2.5	3.0	3.5	4.0	4.5	4.0	3.5	3.0		2.6	1.8
Level 3	1.5	2.3	3.0	3.5	4.0	4.5	5.0	4.5	4.0	3.5		3.0	2.0
Level 4	1.8	2.6	3.5	4.0	4.5	5.0	5.5	5.0	4.5	4.0		3.4	2.3
Level 5	2.0	3.0	4.0	4.5	5.0	5.5	6.0	5.5	5.0	4.5		3.8	2.5
Level 6	2.3	3.4	4.5	5.0	5.5	6.0	6.5	6.0	5.5	5.0		4.1	2.8
Level 7	2.5	3.8	5.0	5.5	6.0	6.5	7.0	6.5	6.0	5.5		4.5	3.0
Level 8	2.8	4.1	5.5	6.0	6.5	7.0	7.5	7.0	6.5	6.0		4.9	3.3
Level 9	3.0	4.5	6.0	6.5	7.0	7.5	8.0	7.5	7.0	6.5		5.3	3.5
Level 10	3.3	4.9	6.5	7.0	7.5	8.0	8.5	8.0	7.5	7.0		5.6	3.8

(WARM-UP and COOL-DOWN last 4:00 minutes each and are included in program times. Units are MPH.)

### PROGRAM: HILL CLIMB (P4)

Simulates climbing and descending a hill by automatically varying incline. 10 difficulty levels to choose from.

#### HILL CLIMB PROGRAM SEGMENTS

TIME	WARM-UP		1	2	3	4	5	6	7	8	9	10	SEGMENTS ARE REPEATED UNTIL SELECTED TIME IS REACHED	COOL-DOWN	
	2:00	2:00	:30	:30	:30	:30	:30	:30	:30	:30	:30	:30		2:00	2:00
Level 1	0.0	0.0	1.0	1.5	2.0	2.5	3.0	3.0	2.5	2.0	1.5	1.0		0.0	0.0
Level 2	0.0	0.0	1.5	2.0	2.5	3.0	3.5	3.5	3.0	2.5	2.0	1.5		0.0	0.0
Level 3	0.0	1.0	2.0	2.5	3.0	3.5	4.0	4.0	3.5	3.0	2.5	2.0		1.0	0.0
Level 4	0.0	1.5	2.5	3.0	3.5	4.0	4.5	4.5	4.0	3.5	3.0	2.5		1.5	0.0
Level 5	0.0	1.5	3.0	3.5	4.0	4.5	5.0	5.0	4.5	4.0	3.5	3.0		1.5	0.0
Level 6	0.0	1.5	3.5	4.0	4.5	5.0	5.5	5.5	5.0	4.5	4.0	3.5		1.5	0.0
Level 7	0.0	1.5	4.0	4.5	5.0	5.5	6.0	6.0	5.5	5.0	4.5	4.0		1.5	0.0
Level 8	0.0	2.0	4.5	5.0	5.5	6.0	6.5	6.5	6.0	5.5	5.0	4.5		2.0	0.0
Level 9	0.0	2.0	5.0	5.5	6.0	6.5	7.0	7.0	6.5	6.0	5.5	5.0		2.0	0.0
Level 10	0.0	2.0	5.5	6.0	6.5	7.0	7.5	7.5	7.0	6.5	6.0	5.5		2.0	0.0

(WARM-UP and COOL-DOWN last 4:00 minutes each and are included in program times. Units in % grade.)

### PROGRAM: CUSTOM (P5)

Lets you create and reuse a perfect workout for you with specific speed, incline and time combination. The ultimate in personal programming. Time-based goal.

- 1) Select **CUSTOM 1** or **2** using the **PROGRAM KEYS**, then press **ENTER**.
- 2) Set **TIME** using the **+/- KEYS** and press **ENTER**.  
NOTE: If the program is previously stored:  
After you set the time and press **START**, the previously stored program will begin.
- 3) Choose the desired **SPEED** for each segment, using the **SPEED ARROW KEYS** and press **ENTER**. Note: You will need to press **ENTER** after each segment.
- 4) Choose the desired **INCLINE** for each segment, using the **INCLINE ARROW KEYS** and press **ENTER**. Note: You will need to press **ENTER** after each segment.
- 5) Press **START** to begin your program.



## PROGRAM: THR ZONE (P6)

Automatically adjusts incline to maintain your Target Heart Rate. Perfect for simulating the intensity of your favorite sport or everyday activity. Time-based goal.

- 1) Select **THR ZONE** using **PROGRAM KEYS**, then press **ENTER**.
- 2) Choose a **TARGET HEART RATE** using the **+/- KEYS** and press **ENTER**.  
**Note:** Use the chart provided in this guide to determine your target heart rate (page 24).
- 3) Set **TIME** using the **+/- KEYS** and press **ENTER**.
- 4) Press **START** to begin your program.
  - At this time, your program has been successfully saved into memory, and can be used for future workouts.
  - To **RESET** your program information and delete it from memory, press and hold the **ENTER** key for 5 seconds (after you have selected the **THR ZONE** program).

After the warm-up period, the **INCLINE** level will increase gradually to get you to the entered **TARGET HEART RATE ZONE**. Once you are at the **TARGET HEART RATE ZONE** (plus or minus 5 beats per minute) the **INCLINE** level will remain until you rise above or drop below your **TARGET HEART RATE ZONE** at which time the incline would adjust accordingly. If there is no heart rate detected, the incline will not change. If your heart rate is 25 beats over your target zone the program will shut down. There is a cool down at the end of the program. At this time, the program will gradually decrease the incline level to give you a smooth cool down.

**60% OF MAX HEART RATE:** Used for beginners and longer workouts. Lower intensity and longer duration helps burn fat more efficiently.

**65% OF MAX HEART RATE:** Used for beginner to intermediate users and mid to long range workouts. Lower intensity and longer duration helps burn fat more efficiently.

**70% OF MAX HEART RATE:** Used for intermediate users and mid range cardio workouts. While this range burns fat it really challenges the cardiovascular system and helps strengthen the heart.

**75% OF MAX HEART RATE:** Used for advanced users and short to mid range cardio workouts. Burns fat, tones muscles and challenges the heart.

**80% OF MAX HEART RATE:** Used for advanced users and short workouts. Burns fat, strengthens and tones muscles, and challenges the entire cardiovascular system.

## USER FAVORITE KEYS

The user favorite keys allow up to two programs and program settings to be saved into memory. Using a favorite key enables you to begin your favorite program quickly. To set a user **FAVORITE KEY**, follow the steps as listed in the "SETTING FAVORITE KEYS" section.

### SETTING FAVORITE KEYS:

- 1) Press and hold the **FAVORITE 1** or **FAVORITE 2** key for five seconds until you hear three beeps. The LED inside the **FAVORITE KEY** will be flashing.  
**\*NOTE:** The **FAVORITE KEYS** can not be programmed if you are already in a program.
- 2) Select preferred program using the **PROGRAM KEYS** and press **ENTER**.  
**\*NOTE:** The **CUSTOM PROGRAM (P5)** can not be saved into a **FAVORITE KEY**.
- 3) For P1, set **TIME**, **INCLINE**, and **SPEED** using the **+/- KEYS** and press **ENTER** after setting each value. For programs P2 through P4, set **LEVEL** and **TIME** using the **+/- KEYS** and press **ENTER** after setting each value. For P6, set **TARGET HEART RATE** and **TIME** using the **+/- KEYS** and press **ENTER** after setting each value.
- 4) After you have selected your settings, press the **FAVORITE KEY** to save the settings or press **START** to begin your program and your settings will automatically be saved.

### USING A FAVORITE KEY:

After you have programmed a **FAVORITE KEY** as listed in the "SETTING FAVORITE KEYS" section, you may use the favorite key. Press the desired **FAVORITE 1** or **FAVORITE 2** key then press **START** to begin the program.

**\*NOTE:** The **FAVORITE 1** and **FAVORITE 2** keys may only be used before starting a program. The keys will not function while in a program.

# CONDITIONING GUIDELINES

ALWAYS CONSULT YOUR PHYSICIAN BEFORE BEGINNING AN EXERCISE PROGRAM.

## HOW OFTEN? (Frequency of Workouts)

The American Heart Association recommends that you exercise at least 3 to 4 days per week to maintain cardiovascular fitness. If you have other goals such as weight or fat loss, you will achieve your goal faster with more frequent exercise. Whether it's 3 days or 6 days, remember that your ultimate goal should be to make exercise a lifetime habit. Many people are successful staying with a fitness program if they set aside a specific time of day to exercise. It doesn't matter whether it's in the morning before breakfast, during lunch hour or while watching the evening news. What's more important is that it's a time that allows you to keep a schedule, and a time when you won't be interrupted. To be successful with your fitness program, you have to make it a priority in your life. So decide on a time, pull out your day planner and pencil in your exercise times for the next month!

## HOW LONG? (Duration of Workouts)

For aerobic exercise benefits, it's recommended that you exercise from between 24 and 60 minutes per session. But start slowly and gradually increase your exercise times. If you've been sedentary during the past year, it may be a good idea to keep your exercise times to as little as five minutes initially. Your body will need time to adjust to the new activity. If your goal is weight loss, a longer exercise session at lower intensities has been found to be most effective. A workout time of 48 minutes or more is recommended for best weight loss results.

## HOW HARD? (Intensity of Workouts)

How hard you workout is also determined by your goals. If you use your treadmill to prepare for a 5K run, you will probably work out at a higher intensity than if your goal is general fitness. Regardless of your long term goals, always begin an exercise program at low intensity. Aerobic exercise does not have to be painful to be beneficial! There are two ways to measure your exercise intensity. The first is by monitoring your heart rate (using the grip pulse handlebars), and the second is by evaluating your perceived exertion level (this is simpler than it sounds!).

## PERCEIVED EXERTION LEVEL

A simple way to gauge your exercise intensity is to evaluate your perceived exertion level. While exercising, if you are too winded to maintain a conversation without gasping, you are working out too hard. A good rule of thumb is to work to the point of exhilaration, not exhaustion. If you cannot catch your breath, it's time to slow down. Always be aware of these warning signs of overexertion.

# TARGET HEART RATE ZONE CHART

## What is Target Heart Rate Zone?

Target Heart Rate Zone tells you the number of times per minute your heart needs to beat to achieve a desired workout effect. It is represented as a percentage of the maximum number of times your heart can beat per minute. Target Zone will vary for each individual, depending on age, current level of conditioning, and personal fitness goals. The American Heart Association recommends working-out at a Target Heart Rate Zone of between 60% and 75% of your maximum heart rate. A beginner will want to workout in the 60% range while a more experienced exerciser will want to workout in the 70-75% range. See chart for reference.

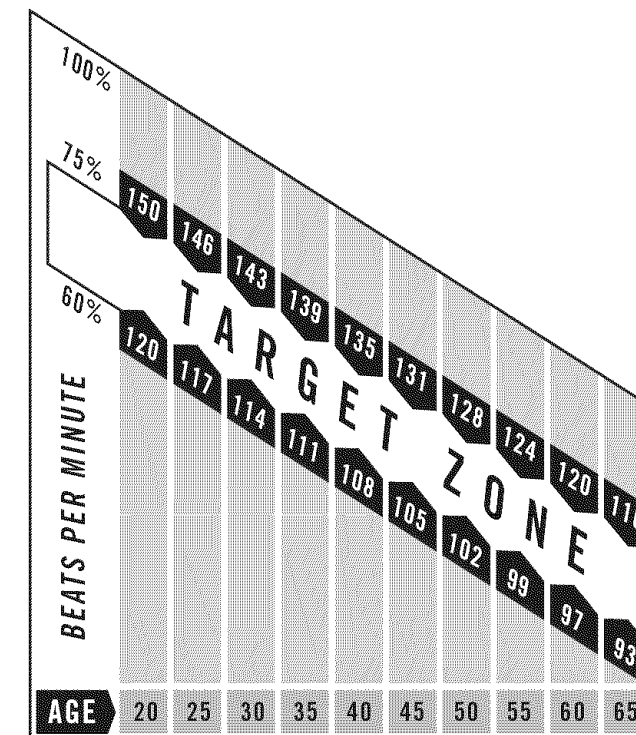

## EXAMPLE:

For a 42-year-old user: Find age along the bottom of the chart (round to 40), follow age column up to the target zone bar. Results: 60% of maximum Heart Rate = 108 Beats Per Minute, 75% of maximum Heart Rate = 135 Beat Per Minute.

ALWAYS CONSULT YOUR PHYSICIAN BEFORE BEGINNING AN EXERCISE PROGRAM.

**TIPS** ✓**STRETCHING****STRETCH FIRST**

Before using your product, it is best to take a few minutes doing a few gentle stretching exercises. Stretching prior to exercise will improve flexibility and reduce chances of exercise related injury. Ease into each of these stretches with a slow gentle motion. Do not stretch to the point of pain. Make sure not to bounce while doing these stretches.

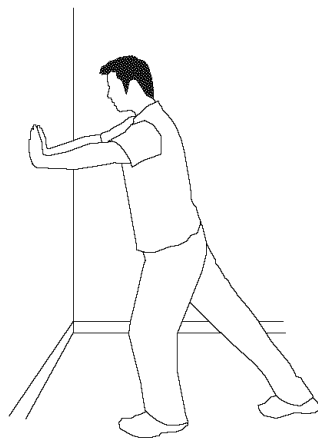
**1. STANDING CALF MUSCLE STRETCH**

Stand near a wall with the toes of your left foot about 18" from the wall, and the right foot about 12" behind the other foot. Lean forward, pushing against the wall with your palms. Keep your heels flat and hold this position for a count of 15 seconds. Make sure that you do not bounce while stretching. Repeat on the other side.

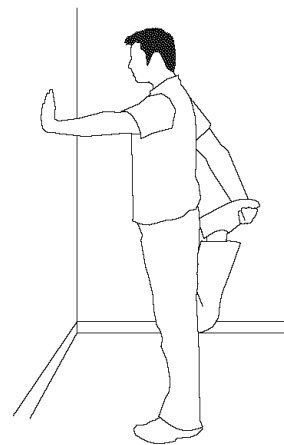
**2. STANDING QUADRICEPS STRETCH**

Using a wall to provide balance, grasp your left ankle with your left hand and hold your foot against the back of your thigh for 15 seconds. Repeat with your right ankle and hand.

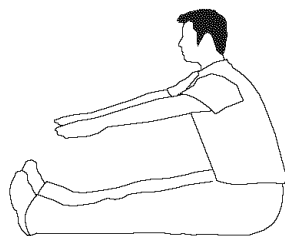
**3. SITTING HAMSTRING & LOWER BACK MUSCLE STRETCH**

Sit on the floor with your legs together and straight out in front of you. Do not lock your knees. Extend your fingers towards your toes and hold for a count of 15 seconds. Make sure that you do not bounce while stretching. Sit upright again. Repeat one time.

**TIPS** ✓**THE IMPORTANCE OF WARM UP & COOL DOWN****WARM UP**

The first 2 to 5 minutes of a workout should be devoted to warming up. The warm-up will limber your muscles and prepare them for more strenuous exercise. Make sure that you warm-up on your product at a slow pace. The warm up should gradually bring your heart rate into your Target Heart Rate Zone.

**COOL DOWN**

Never stop exercising suddenly! A cool-down period of 3-5 minutes allows your heart to readjust to the decreased demand. Make sure that your cool down period consists of a very slow pace to allow your heart rate to lower. After the cool-down, repeat the stretching exercises listed above to loosen and relax your muscles.

**TIPS** ✓**ACHIEVING YOUR FITNESS GOALS**

An important step in developing a long term fitness program is to determine your goals. Is your primary goal for exercising to lose weight? Improve muscle? Reduce stress? Prepare for the spring racing schedule? Knowing what your goals are will help you develop a more successful exercise program. Below are some common exercise goals:

- Weight Loss - lower intensity, longer duration workouts
- Improve Body Shape and Tone - interval workouts, alternate between high and low intensities
- Increased Energy Level - more frequent daily workouts
- Improved Sports Performance - high intensity workouts
- Improved Cardiovascular Endurance - moderate intensity, longer duration workouts

If possible try to define your personal goals in precise, measurable terms, and then put your goals in writing. The more specific you can be, the easier it will be to track your progress. If your goals are long term, divide them up into monthly and weekly segments. Longer term goals can lose some of the immediate motivation benefits. Short term goals are easier to achieve. Your console provides you with several readouts that can be used to record your progress. You can track Distance, Calories or Time.

**KEEPING AN EXERCISE DIARY**

To make your personal exercise log book, photocopy the weekly and monthly log sheets, which are located on the following pages, or you can print them off of your computer by going to:

[www.horizonfitness.com/guides/weeklylog.pdf](http://www.horizonfitness.com/guides/weeklylog.pdf)

[www.horizonfitness.com/guides/monthlylog.pdf](http://www.horizonfitness.com/guides/monthlylog.pdf)

As your fitness improves, you can look back and see how far you've come!

## WEEKLY LOG SHEETS

WEEK #		WEEKLY GOAL				COMMENTS
DAY	DATE	DISTANCE	CALORIES	TIME		
SUNDAY						
MONDAY						
TUESDAY						
WEDNESDAY						
THURSDAY						
FRIDAY						
SATURDAY						
<b>WEEKLY TOTALS :</b>						

WEEK #		WEEKLY GOAL				COMMENTS
DAY	DATE	DISTANCE	CALORIES	TIME		
SUNDAY						
MONDAY						
TUESDAY						
WEDNESDAY						
THURSDAY						
FRIDAY						
SATURDAY						
<b>WEEKLY TOTALS :</b>						

WEEK #		WEEKLY GOAL				COMMENTS
DAY	DATE	DISTANCE	CALORIES	TIME		
SUNDAY						
MONDAY						
TUESDAY						
WEDNESDAY						
THURSDAY						
FRIDAY						
SATURDAY						
<b>WEEKLY TOTALS :</b>						

## MONTHLY LOG SHEETS

MONTH		MONTHLY GOAL		
WEEK #	DISTANCE	CALORIES	TIME	
<b>MONTHLY TOTALS :</b>				

MONTH		MONTHLY GOAL		
WEEK #	DISTANCE	CALORIES	TIME	
<b>MONTHLY TOTALS :</b>				

MONTH		MONTHLY GOAL		
WEEK #	DISTANCE	CALORIES	TIME	
<b>MONTHLY TOTALS :</b>				

# TROUBLESHOOTING

## COMMON PRODUCT QUESTIONS

### ARE THE SOUNDS MY TREADMILL MAKES NORMAL?

All treadmills make a certain type of thumping noise due to the belt riding over the rollers, especially new treadmills. This noise will diminish over time, although may not totally go away. Over time, the belt will stretch, causing the belt to ride smoother over the rollers.

### WHY IS THE TREADMILL I PURCHASED LOUDER THAN THE ONE AT THE STORE?

All fitness products seem quieter in a large store showroom because there is generally more background noise than in your home. Also, there will be less reverberation on a carpeted concrete floor than on a wood overlay floor. Sometimes a heavy rubber mat will help reduce reverberation through the floor. If a fitness product is placed close to a wall, there will be more reflected noise.

### WHEN SHOULD I BE WORRIED ABOUT A NOISE?

As long as the sounds your treadmill makes are no louder than a normal conversational tone of voice, it is considered normal noise.

## TROUBLESHOOTING - TREADMILL

Your treadmill is designed to be reliable and easy to use. However, if you experience a problem, please reference the troubleshooting guide listed below.

**PROBLEM:** The console does not light up and/or the belt does not move.

**SOLUTION:** Verify the following:

#### DOES THE RED LIGHT ON THE ON/OFF SWITCH LIGHT UP?

**IF YES:**

- Double check that all connections are secure, especially the console cable. Unplug and reconnect the console cable to verify.
- Make sure the console cable is not pinched or damaged in any way.
- Turn the power off, unplug the power cable and wait 60 seconds. Remove motor cover. Wait until all red LED lights have gone off on the motor control board before proceeding. Next, verify that none of the wires connected to the lower board are loose or disconnected.

**IF NO:**

- Verify that the outlet the machine is plugged into is functional. Double check that the breaker has not tripped, it is on a dedicated 20-amp circuit, it is not on a GFCI equipped outlet, and it is not plugged into a power strip/surge protector or extension cord.
- The power cord is not pinched or damaged and is properly plugged into the outlet AND the machine.
- The power switch is turned to the ON position.

**PROBLEM:** The treadmill circuit breaker trips during a workout.

**SOLUTION:** Verify the following:

- Make sure the treadmill is plugged into a dedicated 20-amp circuit.
- Verify that you do not have the machine on an extension cord or surge protector.
- Confirm that the machine is not plugged into a GFCI-equipped outlet or on a circuit that has a GFCI-equipped outlet on it.

**PROBLEM:** The running belt does not stay centered during a workout.

**SOLUTION:** Verify the following:

- Make sure the treadmill is on a level surface.
- Verify that the belt is properly tightened and centered (Refer to the Adjustment section for detailed directions).

**PROBLEM:** Operating speed appears inaccurate.

**SOLUTION:** Auto-calibrate the treadmill:

- Power on the treadmill and have the safety key in position on the console. Press and hold the elevation “+” and speed “-” buttons for approximately 5 seconds to enter the Engineering Mode. The console will beep and “ENG0” appears in the display.
- Press the Speed “+” or “-” button until “ENG2” appears in the display.
- Press, “ENTER” to select. Press, “START” to begin. The treadmill running belt will begin to move automatically and the auto-calibration sequence will properly set and store the speed values.
- Upon successful calibration, the treadmill will beep several times. The console will automatically exit Engineering Mode and return to the start-up screen.



**DO NOT** stand on running belt while calibrating – stand on the guide rails. Treadmill will fluctuate between low and high speeds for several minutes until calibration is complete.

## TROUBLESHOOTING - HEART RATE

Check your exercise environment for sources of interference such as fluorescent lights, computers, underground fencing, home security systems or appliances containing large motors. These items may cause erratic heart rate readouts.

You may experience an erratic readout under the following conditions:

- Gripping the heart rate handlebars too tight. Try to maintain moderate pressure while holding onto the heart rate handlebars.
- Constant movement and vibration due to constantly holding the heart rate handlebars while exercising. If you are receiving erratic heart rate readouts, try to only hold the grips long enough to monitor your heart rate.
- When you are breathing heavily during a workout.
- When your hands are constricted by wearing a ring.
- When your hands are dry or cold. Try to moisten your palms by rubbing them together to warm.
- Anyone with heavy arrhythmia.
- Anyone with arteriosclerosis or peripheral circulation disorder.
- Anyone whose palm skin is especially thick.

If the above troubleshooting section does not remedy the problem, discontinue use and turn the power off, and contact Sears for service at 1-800-4-MY-HOME®.

The following information may be asked of you when you call. Please have these items readily available:

- Model Name
- Serial Number

In order for the technician to service your treadmill they may need to ask detailed questions about the symptoms that are occurring. Some troubleshooting questions that may be asked are:

- How long has this problem been occurring?
- Does this problem occur with every use? With every user?
- If you are hearing a noise, does it come from the front or the back? What kind of noise is it (thumping, grinding, squeaking, chirping etc.)?
- Has the machine been lubricated and maintained per the maintenance schedule?

Answering these and other questions will give the technicians the ability to send proper replacement parts and the service necessary to get you and your Horizon Fitness treadmill running again!

## MAINTENANCE

Cleanliness of your treadmill and its operation environment will keep maintenance problems and service calls to a minimum. For this reason, we recommend that the following preventive maintenance schedule be followed.

### AFTER EACH USE (DAILY)

Clean and inspect, following these steps:

- Turn off the treadmill with the on/off switch, then unplug the power cord at the wall outlet.
- Wipe down the running belt, deck, motor cover, and console casing with a damp cloth. Never use solvents, as they can cause damage to the treadmill.
- Inspect the power cord. Replace the power cord if damaged.
- Make sure the power cord is not underneath the treadmill or in any other area where it can become pinched or cut.
- Check the tension and alignment of the running belt. Make sure that the treadmill belt will not damage any other components on the treadmill by being misaligned.

### EVERY WEEK

Clean underneath the treadmill, following these steps:

- Turn off the treadmill with the on/off switch, then unplug the power cord at the wall outlet.
- Fold the treadmill into the upright position, making sure that the lock latch is secure.
- Move the treadmill to a remote location.
- Wipe or vacuum any dust particles or other objects that may have accumulated underneath the treadmill.
- Return the treadmill to its previous position.

### EVERY MONTH - IMPORTANT!

- Turn off the treadmill with the on/off switch, then unplug the power cord at the wall outlet.
- Inspect all assembly bolts of the machine for proper tightness.
- Turn off the treadmill and wait 60 seconds.
- Remove the motor cover. Wait until ALL LED lights turn off.
- Clean the motor and lower board area to eliminate any lint or dust particles that may have accumulated. Failure to do so may result in premature failure of key electrical components.
- Vacuum and wipe down the belt with a damp cloth. Vacuum any black/white particles that may accumulate around the unit. These particles may accumulate from normal treadmill use.

### EVERY 6 MONTHS OR 150 MILES

It is necessary to lubricate your treadmill running deck every six months or 150 miles to maintain optimal performance of your treadmill. Once the treadmill reaches 150 miles, the console will prompt you to lubricate the treadmill. Only use lubricant designated for treadmills; available by calling Sears at 1-800-4-MY-HOME®.

- **TURN OFF THE TREADMILL** with the on/off switch, then unplug the power cord at the wall outlet.
- Loosen both the rear roller bolts. (For best results, place two removable marks on both sides of the frame and note roller position). Once the belt is loosened, take the bottle of lubricant and apply it to the entire top surface of the running deck. Tighten both rear roller bolts (matching up the marks for proper position) to original position. After you have applied lubricant, plug in the power cord, insert the safety key, start the treadmill and walk on the belt for two minutes to spread the lubricant.
- Lubricate the air shocks with Teflon based spray.
- Once lubrication is complete, reset the console by pressing and holding 'STOP' and Speed '+' buttons for 5 seconds.

**NOTE:** The Treadmill will not operate when the message is showing. You may hold STOP for 5 seconds to suspend message for 5 miles.

## LUBRICATION

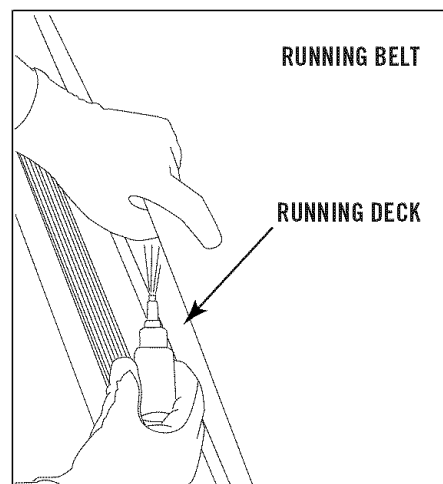

## LIMITED WARRANTY

### One Year Limited Warranty

When assembled, operated and maintained according to all instructions supplied with the product, if this Treadmill fails due to a defect in material or workmanship within one year from the date of purchase, call 1-800-4-MY-HOME® to arrange for free repair.

### Additional Limited Warranty on Specific Parts

From the date of purchase for the time periods listed below, the following specific parts will be supplied free of charge if they fail due to a defect in material or workmanship. After the first 90 days from the date of purchase, you pay for labor to have them installed.

- Eight Years: Motor
- Lifetime: Frame

All warranty coverage is void if this product is ever used for other than private household purposes.

This warranty gives you specific legal rights, and you may also have other rights which vary from state to state.

**Sears, Roebuck and Co., Hoffman Estates, IL 60179**



# Get it fixed, at your home or ours!

## Your Home

For repair – **in your home** – of **all** major brand appliances, lawn and garden equipment, or heating and cooling systems, **no matter who made it, no matter who sold it!**

For the replacement parts, accessories and owner's manuals that you need to do-it-yourself.

For Sears professional installation of home appliances and items like garage door openers and water heaters.

**1-800-4-MY-HOME® (1-800-469-4663)**

Call anytime, day or night (U.S.A. and Canada)

[www.sears.com](http://www.sears.com)    [www.sears.ca](http://www.sears.ca)

## Our Home

For repair of carry-in items like vacuums, lawn equipment, and electronics, call or go on-line for the location of your nearest

**Sears Parts & Repair Service Center**

**1-800-488-1222**

Call anytime, day or night (U.S.A. only)

[www.sears.com](http://www.sears.com)

To purchase a protection agreement (U.S.A.) or maintenance agreement (Canada) on a product serviced by Sears:

**1-800-827-6655** (U.S.A.)

**1-800-361-6665** (Canada)

Para pedir servicio de reparación a domicilio, y para ordenar piezas:

**1-888-SU-HOGAR®**

(1-888-784-6427)

[www.sears.com](http://www.sears.com)

Au Canada pour service en français:

**1-800-LE-FOYER<sup>MC</sup>**

(1-800-533-6937)

[www.sears.ca](http://www.sears.ca)



® Registered Trademark / <sup>TM</sup> Trademark / <sup>SM</sup> Service Mark of Sears Brands, LLC

® Marca Registrada / <sup>TM</sup> Marca de Fábrica / <sup>SM</sup> Marca de Servicio de Sears Brands, LLC

<sup>MC</sup> Marque de commerce / <sup>MD</sup> Marque déposée de Sears Brands, LLC

© Sears Brands, LLC

RST5.6 Rev. 1.4 | © 2006 Horizon Fitness Products | Designed & Engineered in the U.S.A. | Made in China