

FOR MODEL :

RE7.6



HORIZON
FITNESS

ELLIPTICAL ASSEMBLY & USER'S GUIDE

INTRODUCTION

CONGRATULATIONS and **THANK YOU** for your purchase of this Horizon Fitness elliptical!

Whether your goal is to win races or simply enjoy a fuller, healthier lifestyle, a Horizon Fitness elliptical can help you attain it – adding club-quality performance to your at-home workouts, with the ergonomics and innovative features you need to get stronger and healthier, faster. Because we're committed to designing fitness equipment from the inside out, we use only the highest quality components. It's a commitment we back with one of the strongest frame-to-brake warranty packages in the industry.

You want exercise equipment that offers the most comfort, the best reliability and the highest quality in its class.

Horizon Fitness delivers.

TABLE OF CONTENTS

<i>Important Precautions</i>	4
<i>Assembly</i>	5
<i>Before You Begin</i>	17
<i>Elliptical Operation</i>	18
<i>Conditioning Guidelines</i>	28
<i>Troubleshooting & Maintenance</i>	34
<i>Limited Warranty</i>	38
CONTACT INFORMATION	<i>Back Cover</i>

IMPORTANT PRECAUTIONS

SAVE THESE INSTRUCTIONS

Read all instructions before using this elliptical. When using an electrical product, basic precautions should always be followed, including the following: Read all instructions before using this elliptical. It is the responsibility of the owner to ensure that all users of this elliptical are adequately informed of all warnings and precautions. If you have any questions after reading this manual, contact Sears at the number listed on the back cover of this manual.



WARNING To reduce the risk of burns, fire, electrical shock or injury to persons:

- If you experience any kind of pain, including, but not limited to chest pains, nausea, dizziness, or shortness of breath, stop exercising immediately and consult your physician before continuing.
- Maintain a comfortable pace. Do not sprint above 80 rpms on this machine.
- To maintain balance, it is recommended to keep a grip on the handlebars while exercising, mounting or dismounting the machine.
- Do not wear clothes that might catch on any part of the elliptical.
- Do not turn pedal arms by hand.
- Make sure handlebars are secure before each use.
- Do not insert or drop any object into any opening.
- Unplug elliptical before moving or cleaning it. To clean, wipe surfaces down with soap and slightly damp cloth only; never use solvents. (See MAINTENANCE)
- This elliptical should not be used by persons weighing more than 250 pounds. Failure to comply will void the warranty.
- This elliptical is intended for in-home use only. Do not use this elliptical in any commercial, rental, school or institutional setting. Failure to comply will void the warranty.
- Do not use elliptical in any location that is not temperature controlled, such as but not limited to garages, porches, pool rooms, bathrooms, car ports or outdoors. Failure to comply may void the warranty.
- Use the elliptical only as described in this manual.

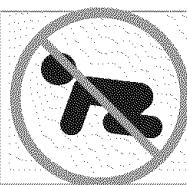

At NO time should pets or children under the age of 12 be closer to the elliptical than 10 feet. At NO time should children under the age of 12 use the elliptical. Children over the age of 12 should not use the elliptical without adult supervision.

It is essential that your elliptical is used only indoors, in a climate controlled room. If your elliptical has been exposed to colder temperatures or high moisture climates, it is strongly recommended that the elliptical is warmed up to room temperature before first time use. Failure to do so may cause premature electronic failure.

ASSEMBLY

IMPORTANT: READ THESE SAFETY INSTRUCTIONS BEFORE USE!



There are several areas during the assembly process of a elliptical that special attention must be paid. It is very important to follow the assembly instructions correctly and to make sure all parts are firmly tightened. If the assembly instructions are not followed correctly, the elliptical could have frame parts that are not tightened and will seem loose and may cause irritating noises. To prevent damage to the elliptical, the assembly instructions must be reviewed and corrective actions should be taken.

UNPACKING

Unpack the product where you will be using it. Place the product on a level flat surface. It is recommended that you place a protective covering on your floor. During each assembly step, ensure that ALL nuts and bolts are in place and partially threaded in before completely tightening any ONE bolt.

NOTE: A light application of grease may aid in the installation of hardware. Any grease, such as lithium bike grease is recommended.

Before proceeding, find your elliptical's serial number located on the front stabilizer tube and enter it in the space provided below. Also locate the model name which is located on the side cover badge.

ENTER YOUR SERIAL NUMBER AND MODEL NAME IN THE BOXES BELOW:

SERIAL NUMBER:

MODEL NAME:

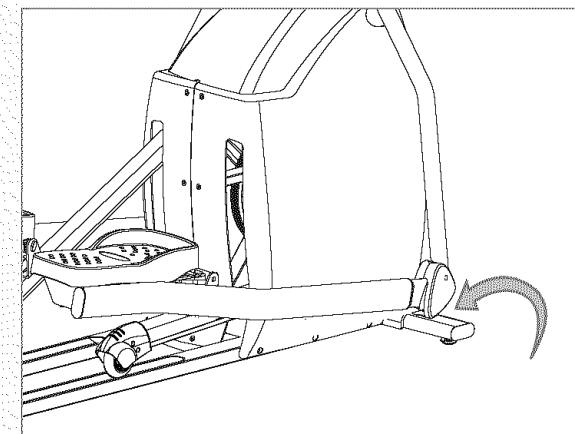

* Refer to the SERIAL NUMBER and MODEL NAME when calling for service.

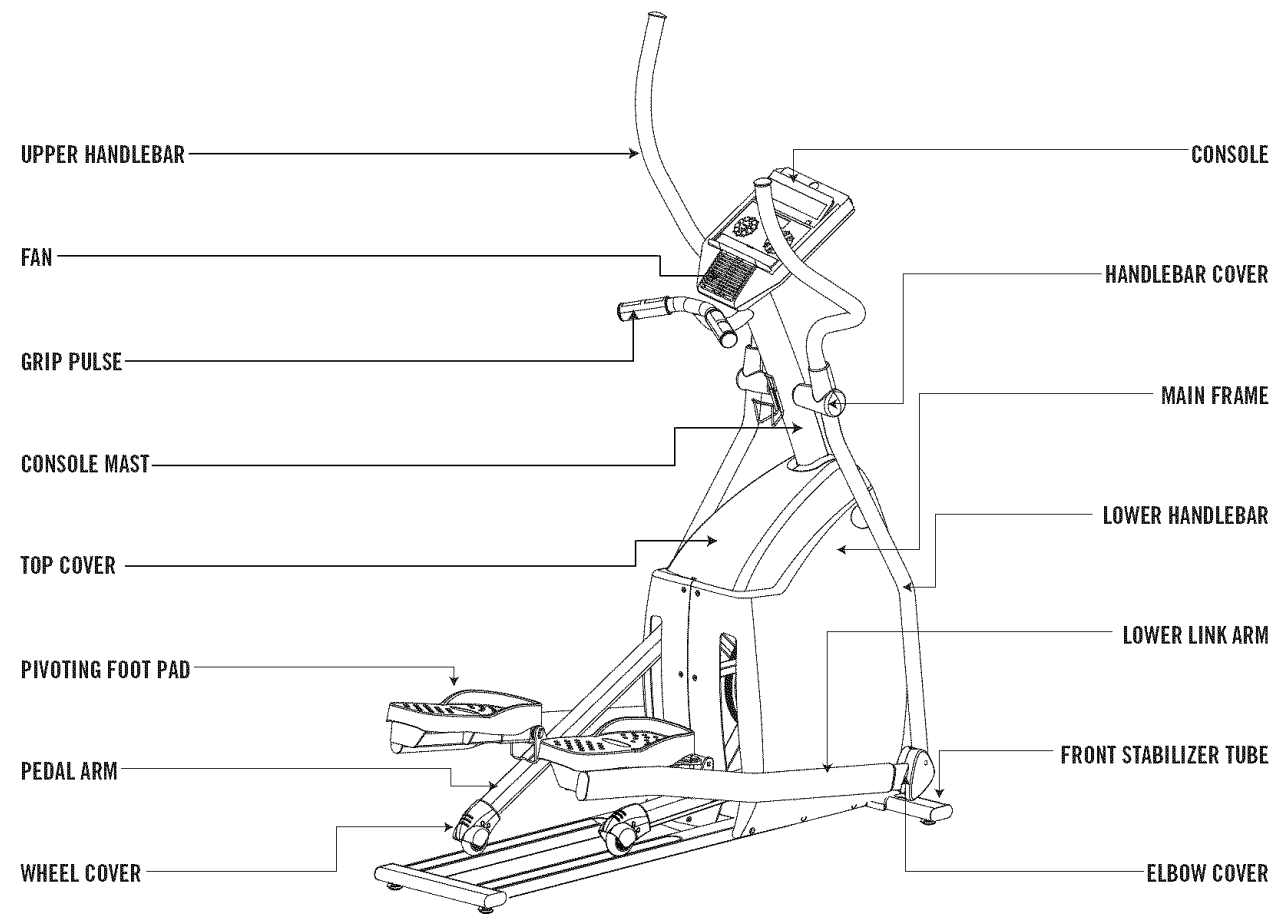
**TOOLS INCLUDED**

- 5mm Allen Wrench
- 6mm Allen Wrench
- Phillips Screw Driver
- 13/15mm Flat Wrench

PARTS INCLUDED

- 1 Console
- 1 Console Mast
- 1 Front Stabilizer Tube
- 2 Upper Handlebars
- 2 Lower Handlebars
- 2 Lower Link Arms
- 2 Pivoting Foot Pads
- 2 Top Covers
- 1 HORIZON FITNESS
12-volt Power Supply
- 2 Handlebar Covers
- 5 Hardware Bags
- 2 Elbow Covers
- Water Bottle Cage

If you have questions or if there are any missing parts, contact 1-800-4-MY-HOME®.
Further contact information is located on the back cover of this manual.

For a complete exploded diagram, see Quick Start and Parts Guide (included in User's Guide bag).

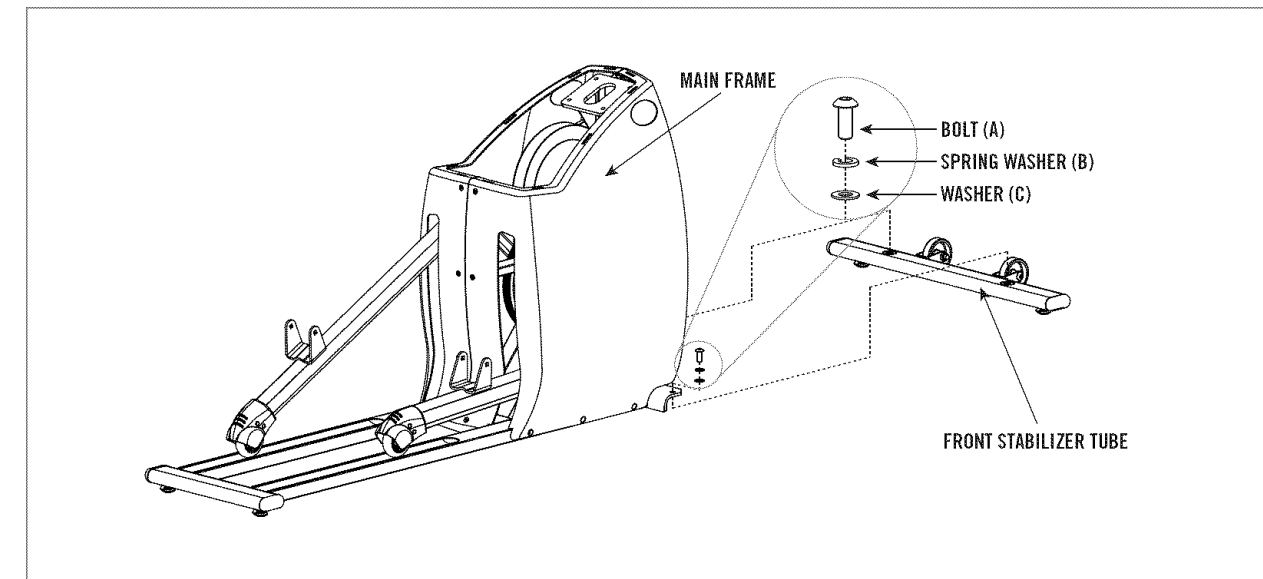
ASSEMBLY STEP 1

A) Open **HARDWARE BAG FOR STEP 1**.

B) Attach the **FRONT STABILIZER TUBE** to the **MAIN FRAME** using 2 **BOLTS (A)**, 2 **SPRING WASHERS (B)** and 2 **FLAT WASHERS (C)**.

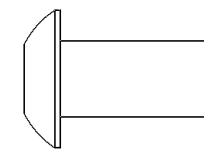
HARDWARE BAG FOR STEP 1 CONTENTS :

BOLT (A)
20 mm
Qty: 2

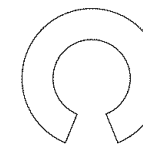

SPRING WASHER (B)
18 mm
Qty: 2

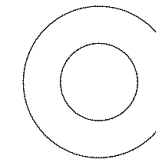

FLAT WASHER (C)
20 mm
Qty: 2

ASSEMBLY STEP 2

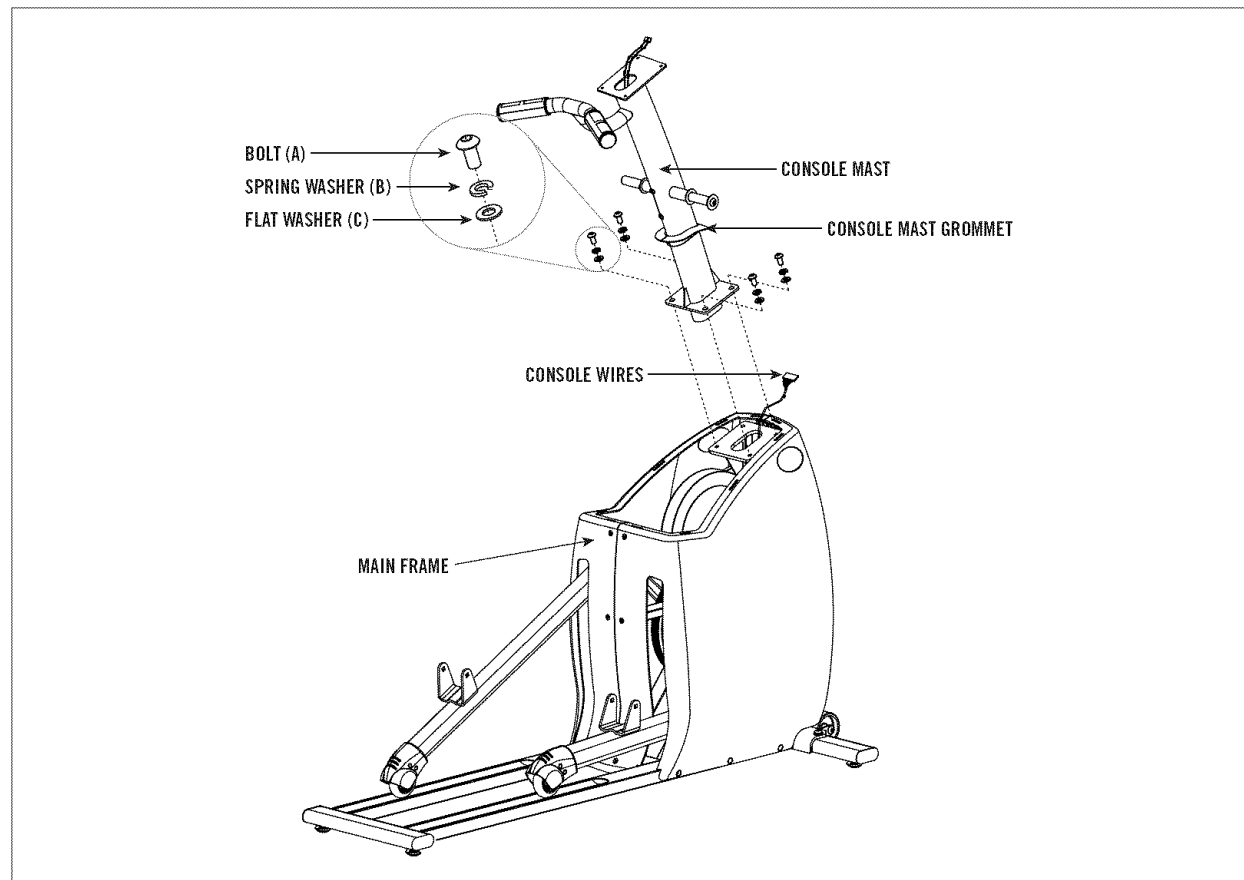

- A) Open **HARDWARE BAG FOR STEP 2**.
- B) Carefully pull the **CONSOLE WIRES** through the **CONSOLE MAST** using the twist tie located inside the **CONSOLE MAST**.
- C) Attach the **CONSOLE MAST** to the **MAIN FRAME** using 4 **BOLTS (A)**, 4 **SPRING WASHERS (B)** and 4 **FLAT WASHERS (C)**.

HARDWARE BAG FOR STEP 2 CONTENTS:

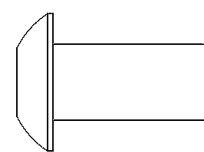

BOLT (A)
20 mm
Qty: 4

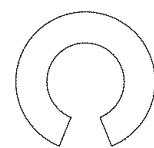

SPRING WASHER (B)
18 mm
Qty: 4

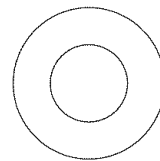

FLAT WASHER (C)
20 mm
Qty: 4

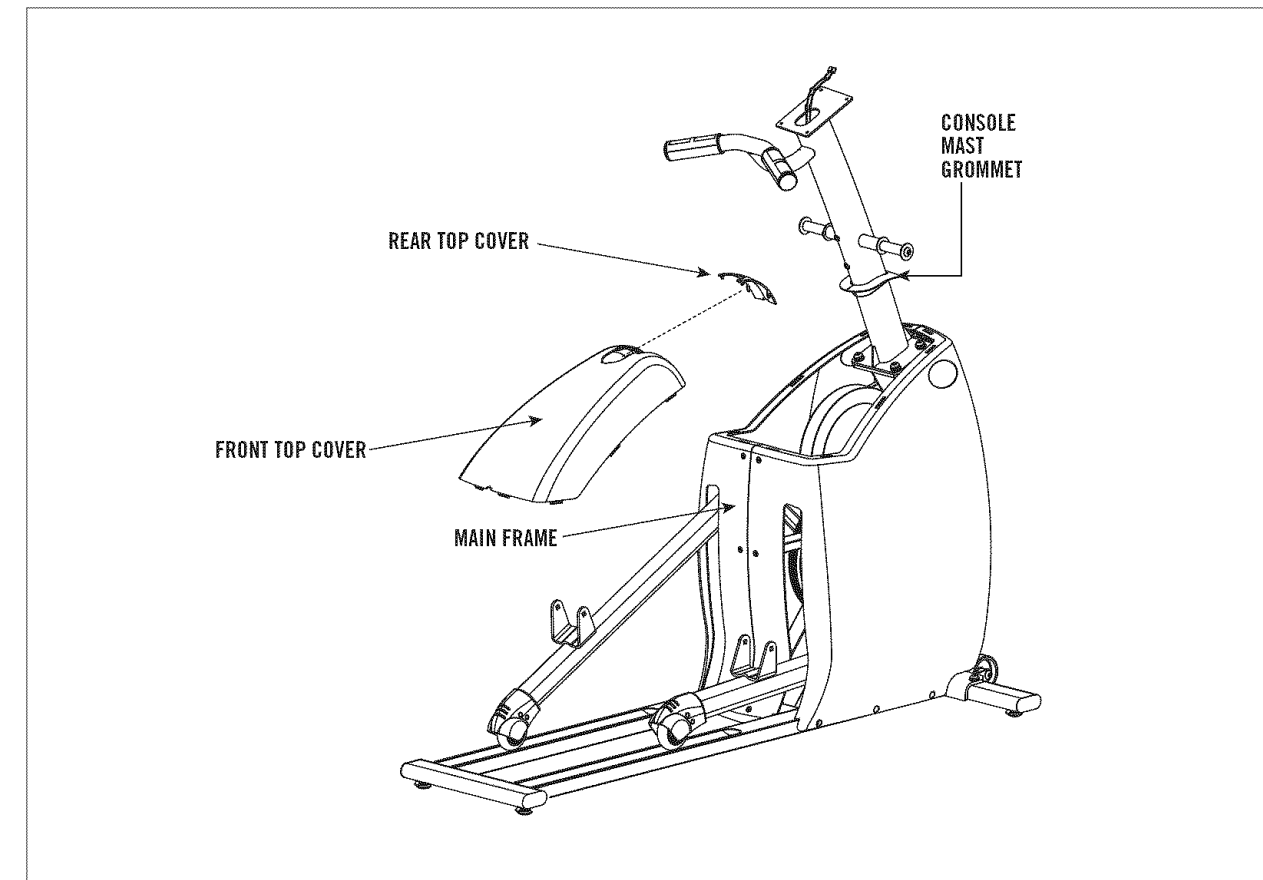

- D) Insert the **FRONT TOP COVER**, followed by the **REAR TOP COVER** and snap them together.
- E) Slide **CONSOLE MAST GROMMET** down to seal the console mast hole.

ASSEMBLY STEP 3

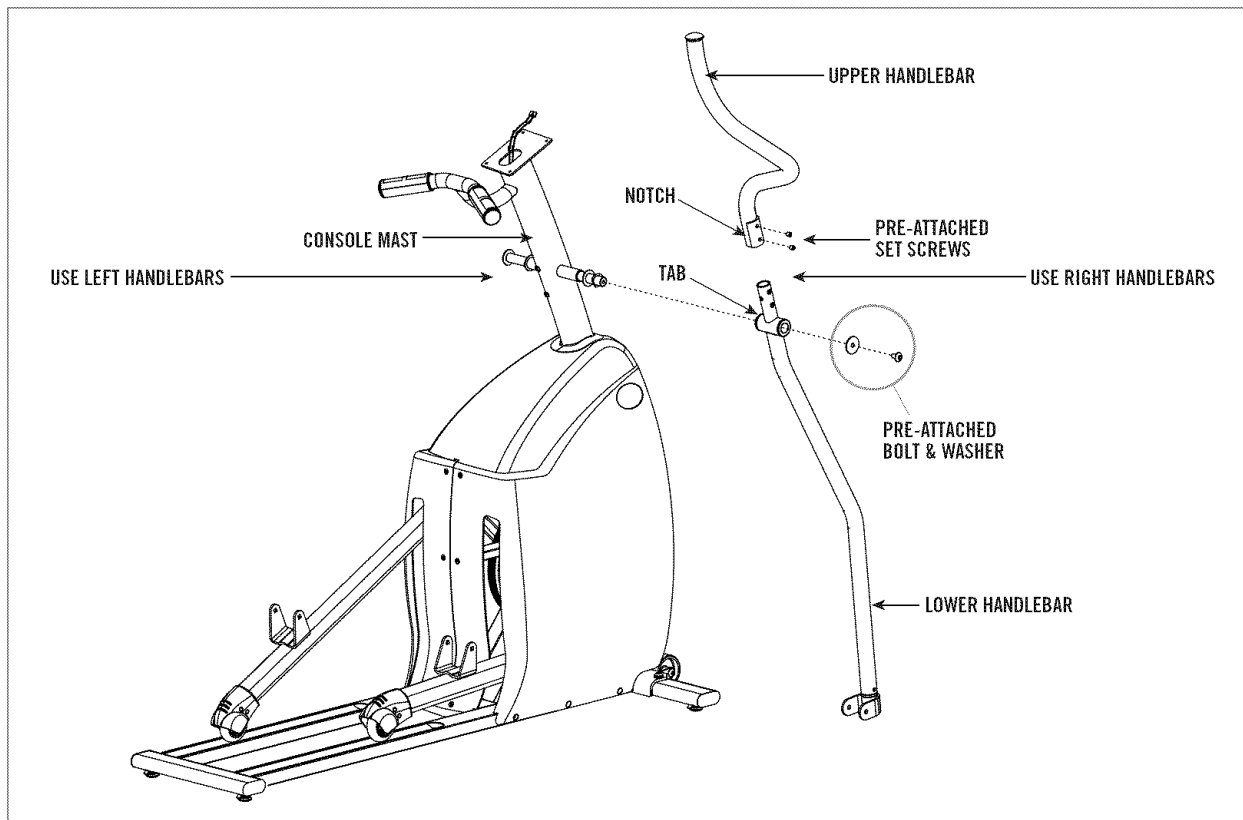

NOTE: There is NO hardware bag for this step. All hardware is pre-installed.

- Remove **PRE-ATTACHED BOLT & WASHERS** from **CONSOLE MAST**.
- Slide **LOWER HANDLEBARS** onto **CONSOLE MAST** and attach by re-inserting **PRE-ATTACHED BOLT & WASHERS**.
- Slide **UPPER HANDLEBARS** onto **LOWER HANDLEBARS** and align **NOTCH** with **TAB** making sure handlebars are joined together completely. Secure **UPPER HANDLEBARS** to **LOWER HANDLEBARS** using **PRE-ATTACHED SET SCREWS**.

*Reminder: The upper and lower handlebars are marked with an **L** if they are to be used on the left-hand side of the elliptical or an **R** if they are to be used on the right-hand side of the elliptical. If the handlebars are assembled on the incorrect side of the elliptical, the unit will not function correctly.*



After handlebars are assembled they will rotate freely – be cautious. Until the machine is fully assembled, do not grab the handlebars for support.

ASSEMBLY STEP 4

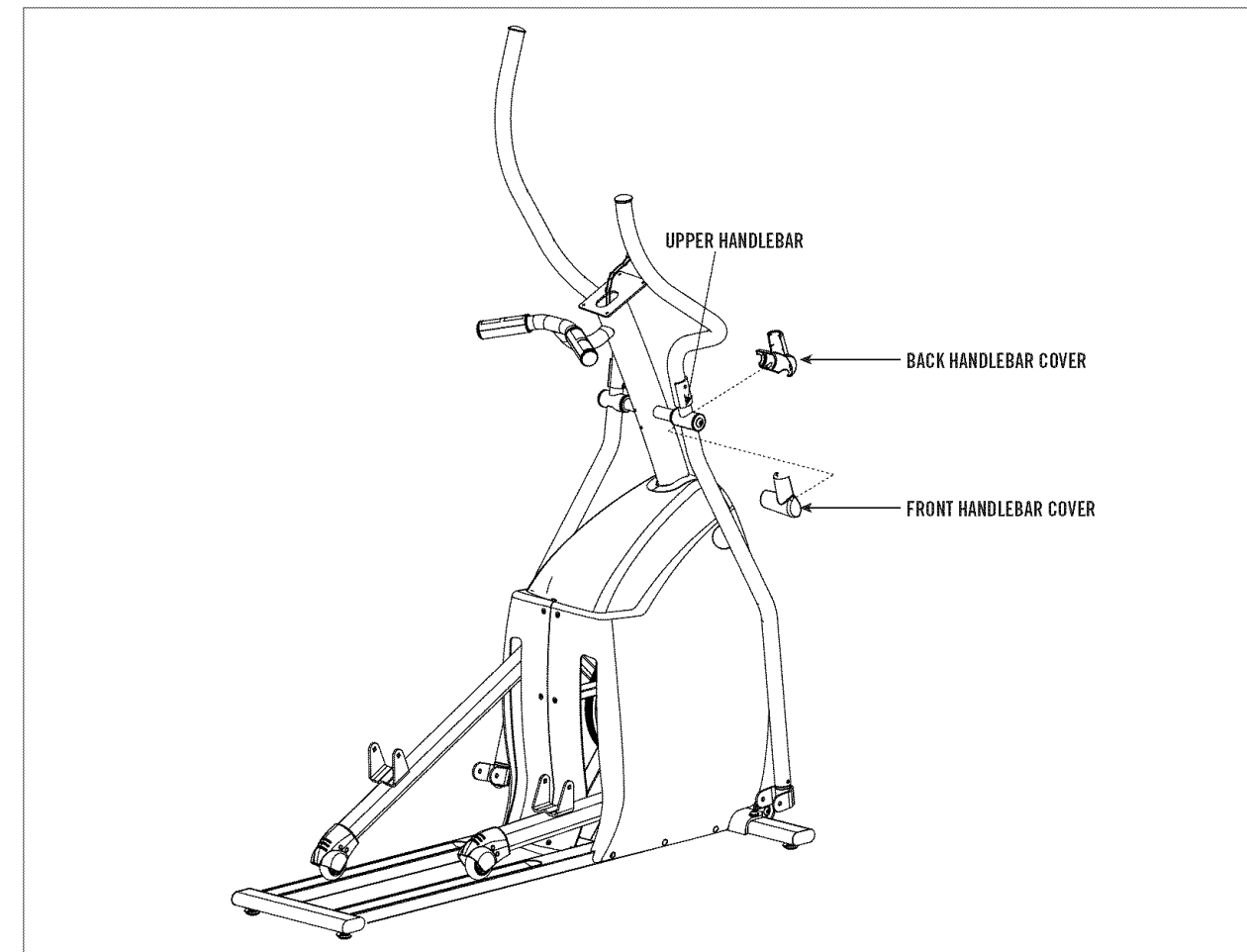

NOTE: There is NO hardware bag for this step.

- Snap the front and back **HANDLEBAR COVERS** together onto the **UPPER HANDLE BARS**. Note the position of the snap tabs on the covers before snapping into position.
- Repeat on other side.

ASSEMBLY STEP 5

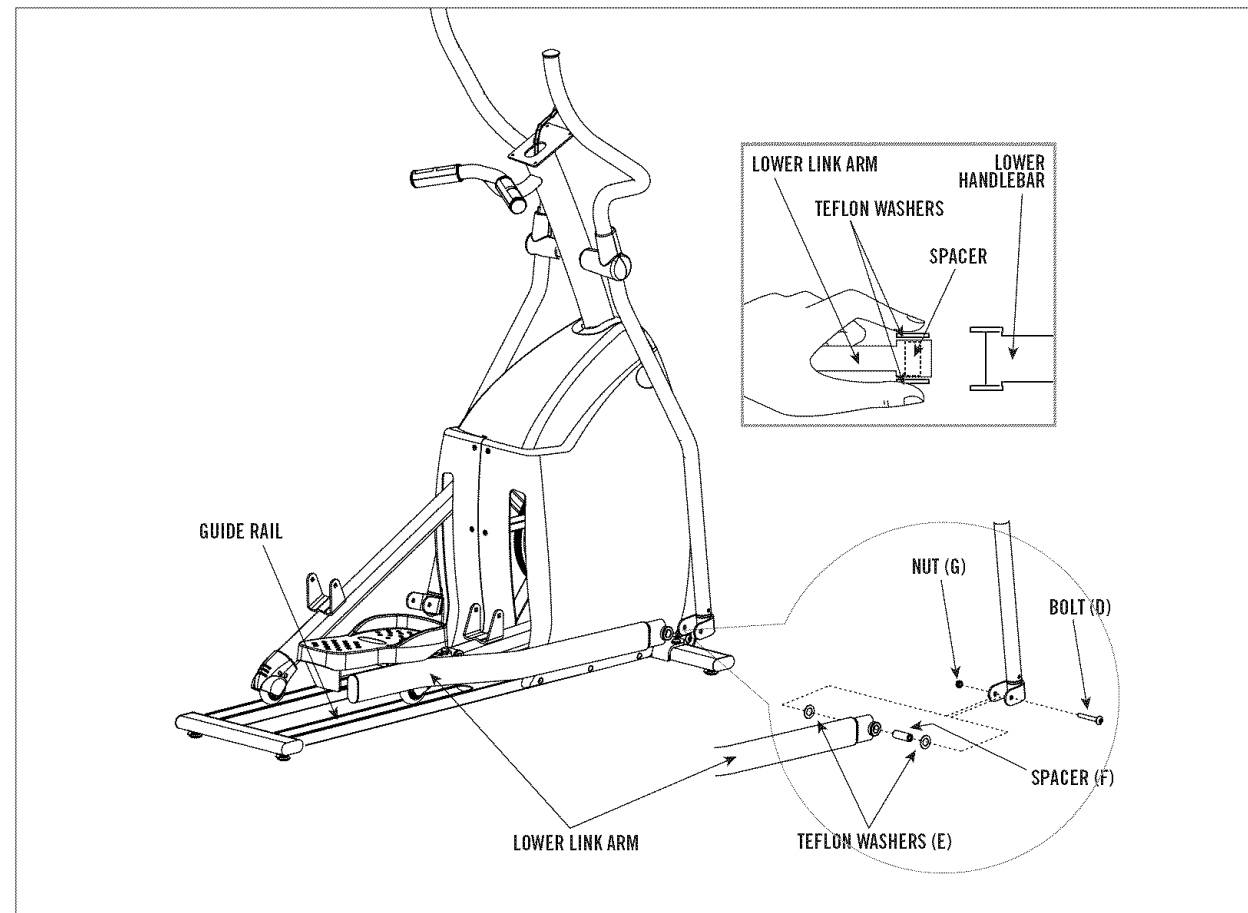

- A) Open **HARDWARE BAG FOR STEP 5**.
- B) Slide **SPACER (F)** into **LOWER HANDLEBAR**.
- C) Place **TEFLON WASHERS (E)** on either side of **SPACER (F)**. While holding **TEFLON WASHERS (E)** slide **LOWER LINK ARM** into bottom end of **LOWER HANDLEBAR**.
- D) Insert **BOLT (D)** into **LOWER HANDLEBAR** and secure using **NUT (G)**.
- E) Repeat on other side.

HARDWARE BAG FOR STEP 5 CONTENTS :

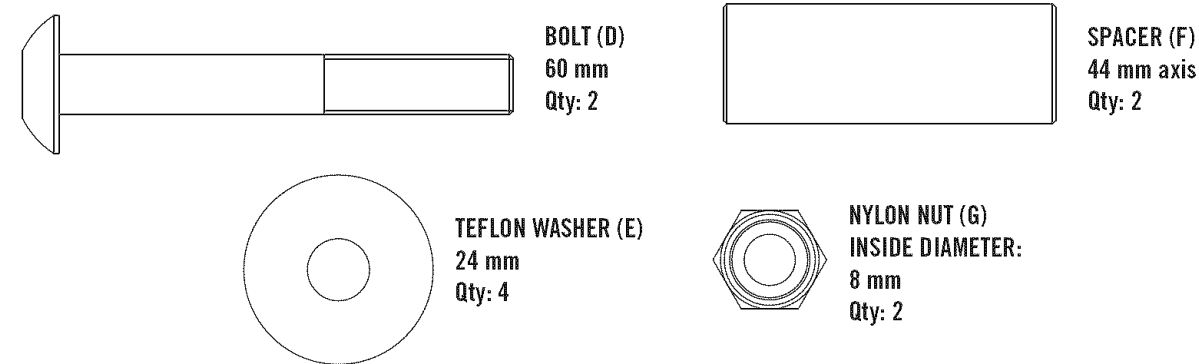

ASSEMBLY STEP 6

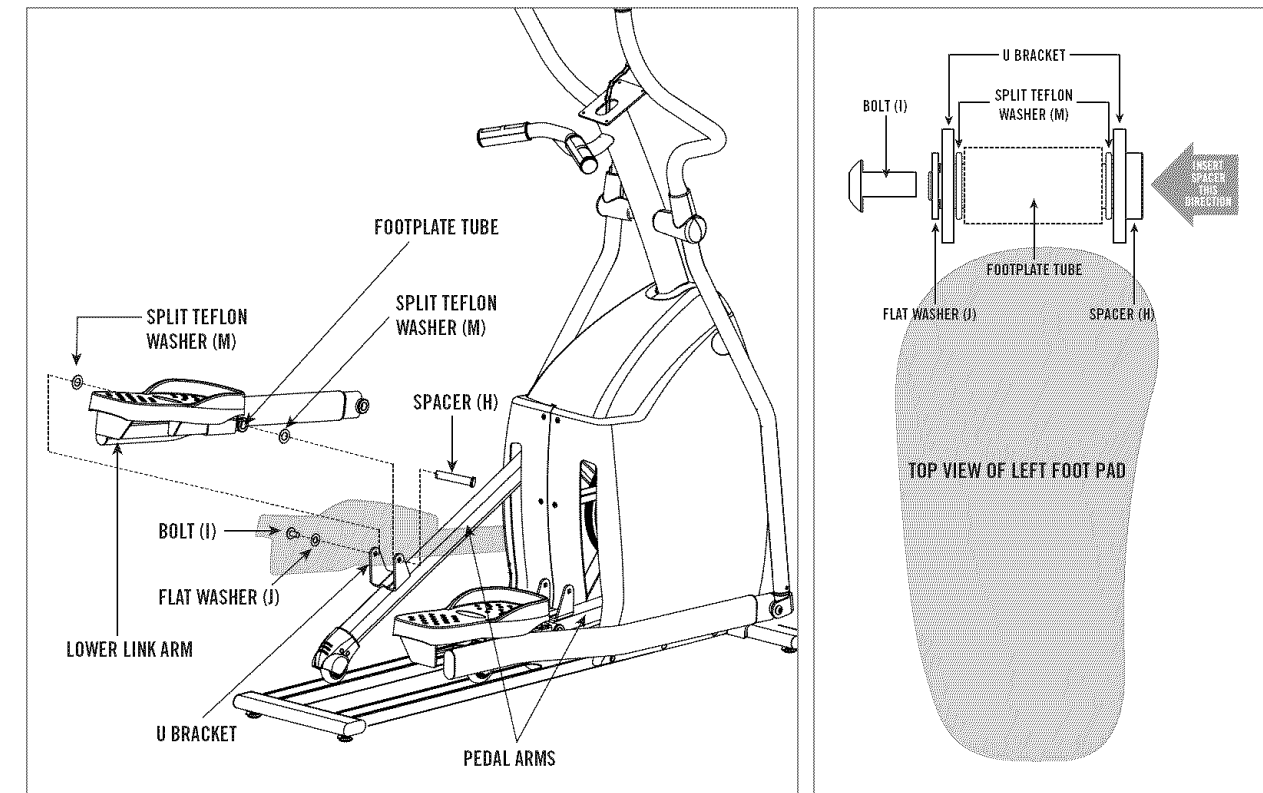

- A) Open **HARDWARE BAG FOR STEP 6**.
- B) Align **LOWER LINK ARM** with **U BRACKET**.
- CAUTION:** Be careful to keep the **LOWER LINK ARM** aligned with guide rail. Do not twist it to the left or right while positioning it on the **U BRACKET**.
- C) Slide **SPACER (H)** through **U BRACKET** and **FOOTPLATE TUBE**.
- D) Insert **FLAT WASHER (J)** and **BOLT (I)** into outside end of **FOOTPLATE TUBE**.
- E) Insert 2 **SPLIT TEFLON WASHERS (M)** on left and right sides of **FOOTPLATE TUBE** and tighten **BOLT (I)**.
- F) Repeat on other side.

HARDWARE BAG FOR STEP 6 CONTENTS :

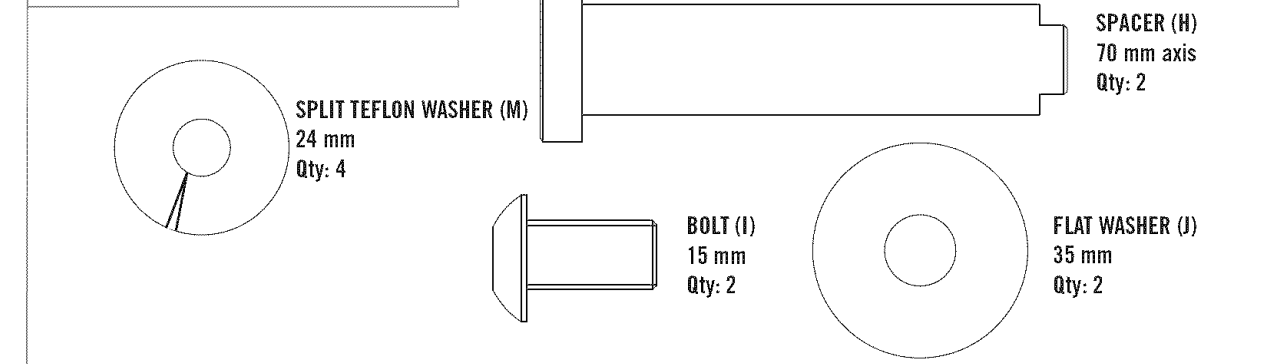

ASSEMBLY STEP 7

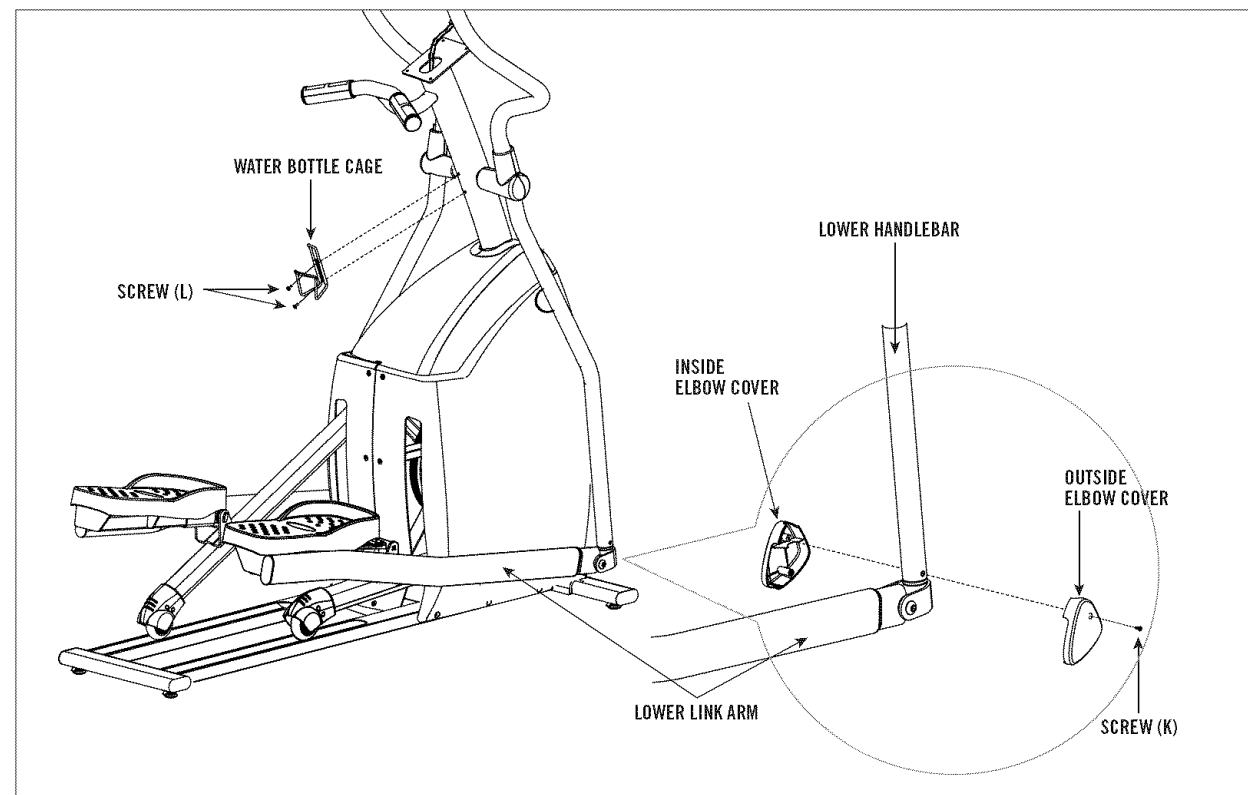

- A) Open **HARDWARE BAG FOR STEP 7**.
- B) Attach the **OUTSIDE ELBOW COVER** to elbow joint using 1 **SCREW (K)**.
- C) Snap the **INSIDE ELBOW COVER** onto the **OUTSIDE ELBOW COVER**.
Note the position of the snap tabs before snapping into position.
- D) Repeat on other side.
- E) Install **WATER BOTTLE CAGE** to console mast using 2 **SCREWS (L)**.

HARDWARE BAG FOR STEP 7 CONTENTS :



SCREW (K)
10 mm
Qty: 2

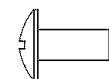

SCREW (L)
15 mm
Qty: 2

ASSEMBLY STEP 8

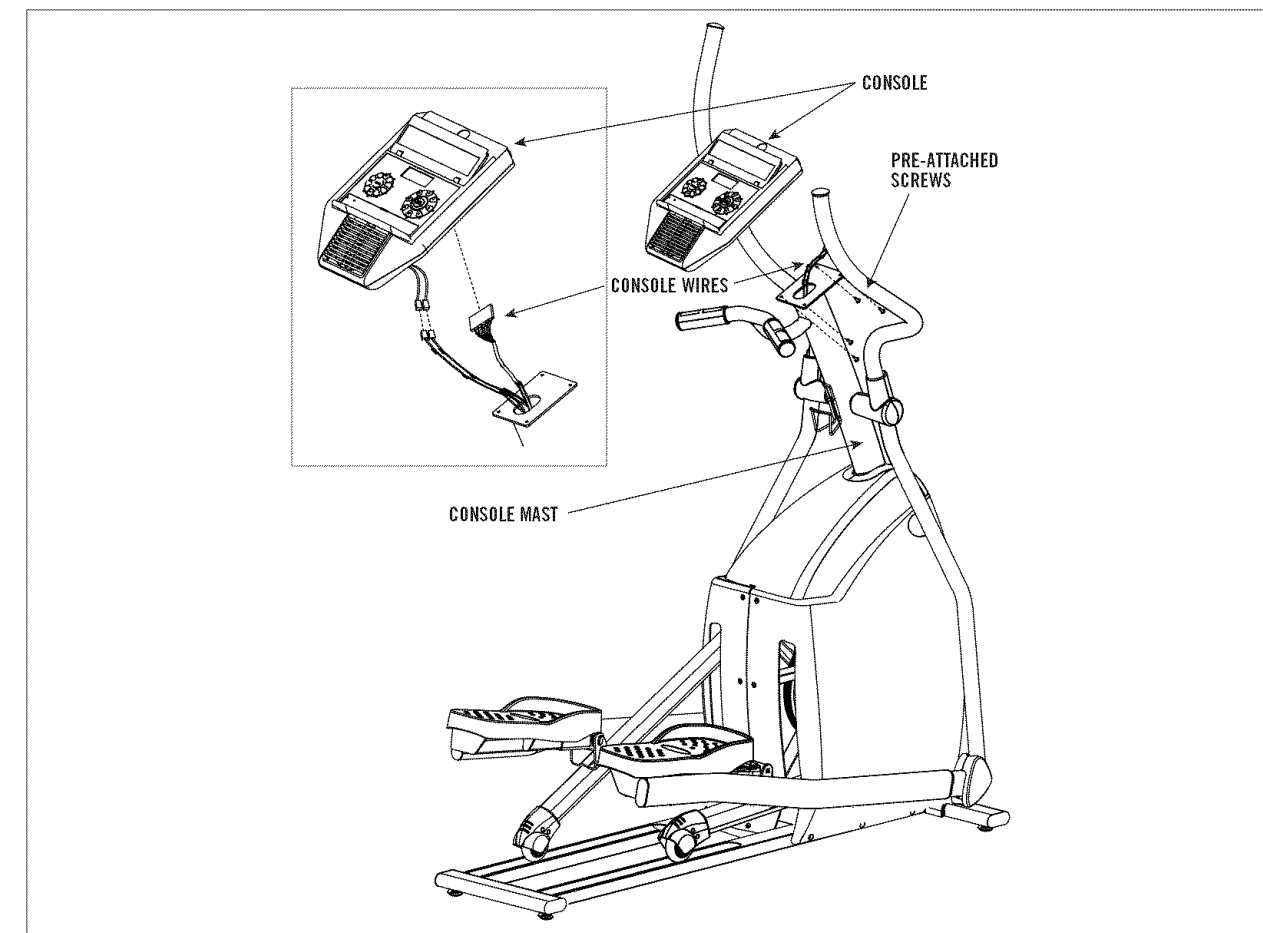

NOTE: There is NO hardware bag for this step. All hardware is pre-installed.

- A) Attach the **CONSOLE MAST** wires to the **CONSOLE** wires.
- B) Carefully tuck the **CONSOLE MAST** wires into the **CONSOLE MAST** before attaching the **CONSOLE**.
- C) Attach **CONSOLE** to the **CONSOLE MAST** using the 4 **PRE-ATTACHED SCREWS** (screws will have to be removed from the console first).

DO NOT PINCH WIRES!

YOU'RE FINISHED!

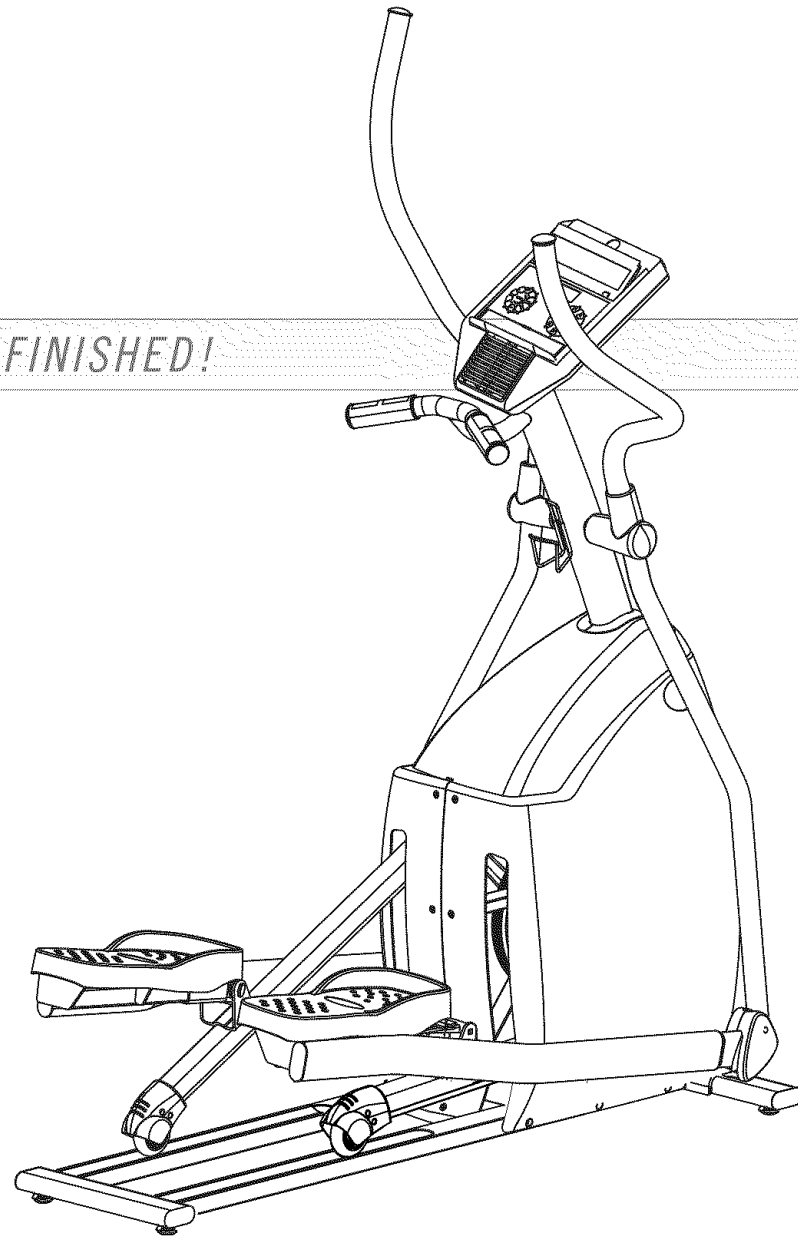

RE7.6

BEFORE YOU BEGIN

CONGRATULATIONS! on choosing your elliptical. You've taken an important step in developing and sustaining an exercise program! Your elliptical is a tremendously effective tool for achieving your personal fitness goals. Regular use of your elliptical can improve the quality of your life in so many ways.

HERE ARE JUST A FEW OF THE HEALTH BENEFITS OF EXERCISE:

- Weight Loss
- A Healthier Heart
- Improved Muscle Tone
- Increased Daily Energy Levels

The key to reaping these benefits is to develop an exercise habit. Your new elliptical will help you eliminate obstacles that prevent you from exercising. Inclement weather and darkness won't interfere with your workout when you use your elliptical in the comfort of your home. This guide provides you with basic information for using and enjoying your new machine.

LOCATION OF THE ELLIPTICAL

Place the elliptical on a level surface. There should be 6 feet of clearance behind the elliptical, 3 feet on each side and one foot in front for the power cord (See diagram to the right). Do not place the elliptical in any area that will block any vent or air openings. The elliptical should not be located in a garage, covered patio, near water or outdoors.

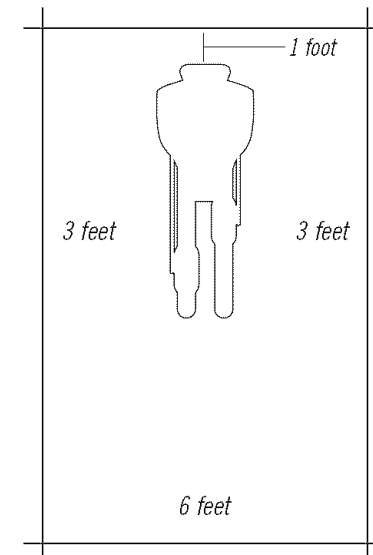

ELLIPTICAL OPERATION

POWER

Your programmable elliptical is powered by a power supply. The power must be plugged into the power jack, which is located in the front of the machine near the STABILIZER TUBE. Make sure the console power switch is in the ON position.



Do not operate the elliptical if the power cord or plug is damaged. If the elliptical appears to not be working properly, do not use the elliptical.

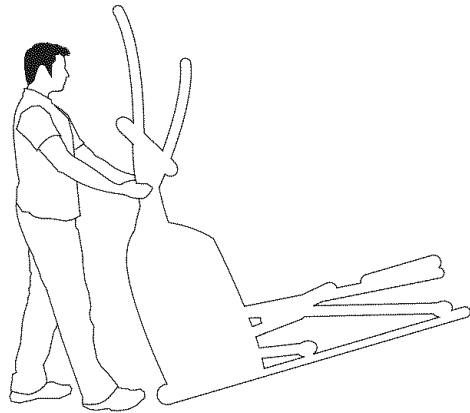

MOVING

Your elliptical has a pair of transport wheels built into the FRONT STABILIZER TUBE. To move, first remove the power supply and firmly grasp the CONSOLE MAST, carefully tilt and roll.



Our ellipticals are well built and heavy, weighing up to 200 lbs! Use care and additional help if necessary when moving.

FOOT POSITIONING

Your elliptical offers a variety of foot positions. Moving your foot to the forward most position of the foot pad increases your step height, which will create a feel similar to a step machine. Placing your foot toward the back of the foot pad decreases your step height and creates more of a gliding feel, similar to a smooth walk or run.

Your elliptical also allows you to pedal both forward and backwards to offer a variation to your workout and to focus on other major leg muscle groups such as your hamstrings and calves.

RE7.6 CONSOLE DISPLAY

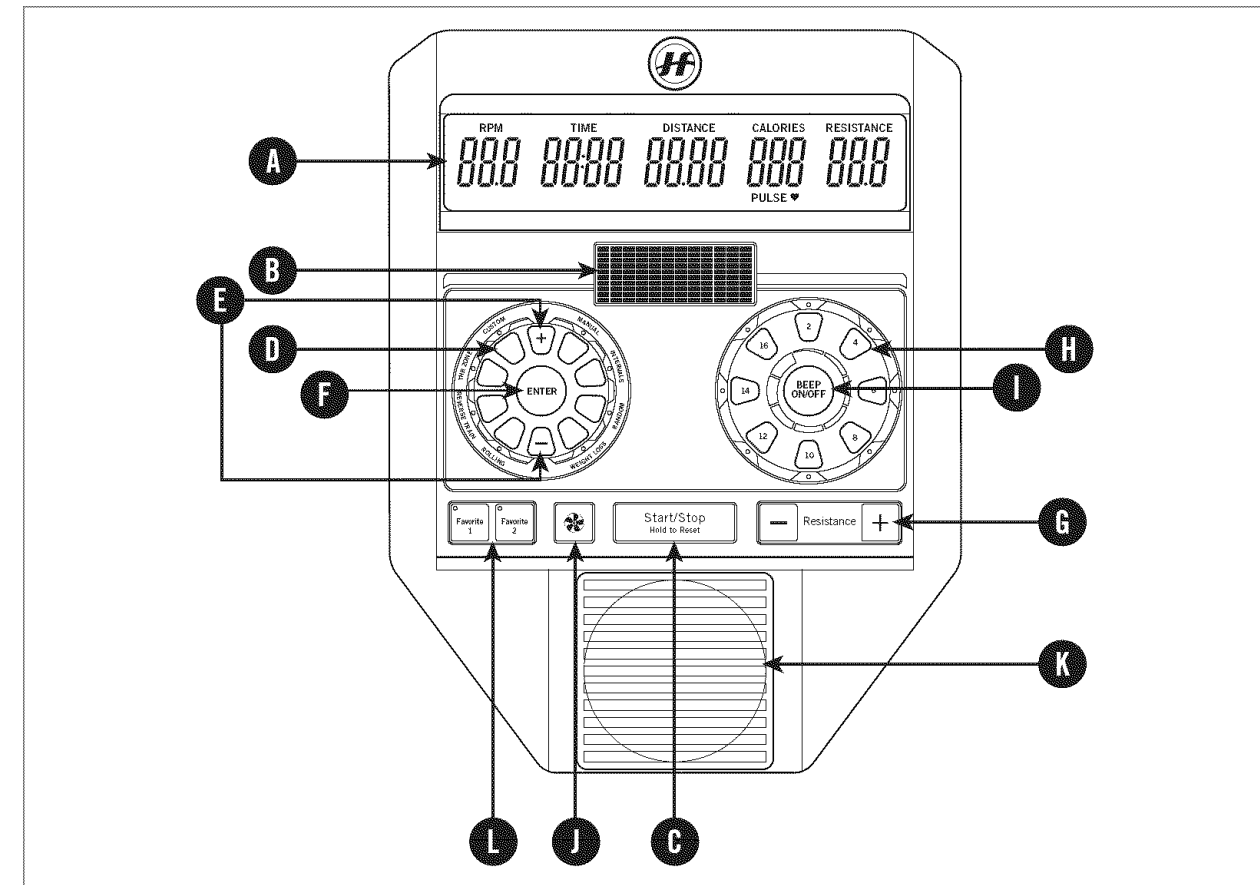

- A) **ADJUSTABLE MONITOR DISPLAY:** RPM, Time, Distance, Calories, Pulse, Resistance.
- B) **PROGRAM MATRIX:** Displays program profiles and scrolling messages.
- C) **START/STOP:** Press to start/pause/end your workout. Hold for 3 seconds to reset the elliptical.
- D) **PROGRAM KEYS:** Used to select your program (Manual, Intervals, Random, Weight Loss, Rolling, Reverse Train, THR Zone, Custom).
- E) **+/- KEYS:** Used to adjust program settings.
- F) **ENTER:** Used to confirm settings.
- G) **RESISTANCE UP/DOWN KEYS:** Used to adjust resistance.
- H) **ONE-TOUCH RESISTANCE KEYS:** Used to reach desired resistance more quickly.
- I) **BEEP ON/OFF:** Used to turn off indicator sound.
- J) **FAN KEY:** Used to adjust fan to 3 speed levels.
- K) **FAN:** Personal workout fan.
- L) **USER FAVORITE KEYS:** Retains a user's favorite program settings in memory.

RE7.6 CONSOLE OPERATION

QUICK START

- 1) Turn on Elliptical.
- 2) Press **START** button and begin exercising.
- 3) Program will automatically default to **MANUAL (P1)**, the time will count up from 0:00 and the resistance will default to level 1.
- 4) The resistance level can be adjusted during the workout.

SELECTING PROGRAMS

- 1) Select a program using the **PROGRAM KEYS** and press **ENTER**.
 - *NOTE: If you press **START**, the program will begin and count down from 30:00. The program defaults to level 1.
- 2) Select a **LEVEL** using the +/- **KEYS** and press **ENTER**.
- 3) Set **TIME** using the +/- **KEYS** and press **START** to begin the program.
 - Count-down range is 20:00 to 99:00 minutes (except **MANUAL** which can be set for 5:00 to 99:00)
 - Select desired time and press **ENTER**.

SELECTING THR ZONE PROGRAM

- 1) Select **THR ZONE** program (P7) using the **PROGRAM KEYS** and press **ENTER**.
 - The **CALORIES/PULSE** window will flash showing the default target heart rate of 80 beats per minute.
- 2) Set **TARGET HEART RATE** (from the chart on page 29) using the +/- **KEYS** and press **ENTER**.
 - *NOTE: Target beats per minute is selected in intervals of 5
- 3) Select **TIME** using the +/- **KEYS** and press **START** to begin the program.

NOTES:

- 1) There is a 4-minute warm-up built into this program at level 1 resistance.
- 2) After 4 minutes the resistance will automatically adjust to bring your heart rate within 5 beats of the target number you selected at the beginning of the program.
- 3) If there is no Heart Rate detected, the resistance will not change.
- 4) If your Heart Rate is 25 beats over your Target Zone the program will shut down.
- 5) There is a 4-minute cool-down built into this program.

SELECTING CUSTOM PROGRAM

- 1) Select **CUSTOM PROGRAM (P8)** using the **PROGRAM KEYS** and press **ENTER**.
- 2) Set **TIME** using the +/- **KEYS** and press **ENTER**.
 - IF THE PROGRAM IS PREVIOUSLY STORED – After you set the time and press **START** the previously stored program will begin.
- 3) Set the **RESISTANCE PROFILES** using the +/- **KEYS** and press **ENTER** after each **RESISTANCE PROFILE** is set to the desired level (repeat until all 15 segments are chosen).
 - *NOTE: If **START** is pressed it will take you back to previous segment.
- 4) After the 15th segment is set, press **ENTER** to save the program then press **START** to begin the program.
 - *NOTE: To reset the memory press and hold the **ENTER** button for 5 seconds.

PROGRAM PROFILES



MANUAL (P1)

Allows you to adjust the resistance level to your preference.



INTERVALS (P2)

Improves your strength, speed and endurance by raising and lowering the resistance levels throughout your workout to involve both your heart and muscles.



RANDOM (P3)

Provides even more workout variety by mixing up your resistance intervals in no particular order.



WEIGHT LOSS (P4)

Promotes weight loss by raising and lowering the resistance level, while keeping you in your fat burning zone.



ROLLING (P5)

Creates the feeling of moving up and down hills by gradually increasing and decreasing the resistance.



REVERSE TRAIN (P6)

Program cues you to pedal forward and backwards for an exciting and challenging workout.



THR ZONE (P7)

Automatically adjusts the resistance level to keep your heart rate in your desired range.



CUSTOM (USER PROGRAM) (P8)

Design and store your own custom exercise program.

USER FAVORITE KEYS

The **USER FAVORITE KEYS** allow up to two programs and program settings to be saved into memory. Using a favorite key enables you to begin your favorite program quickly. To set a **USER FAVORITE KEY**, follow the steps listed in the “SETTING FAVORITE KEYS” section.

SETTING FAVORITE KEYS

- 1) Press and hold the **FAVORITE 1** or **FAVORITE 2** key for five seconds until you hear three beeps. The LED inside the **FAVORITE KEY** will be flashing.
***NOTE:** The **FAVORITE KEYS** cannot be programmed if you are already in a program.
- 2) Select preferred program using the **PROGRAM KEYS** and press **ENTER**.
***NOTE:** The **CUSTOM PROGRAM (P8)** cannot be saved into a **FAVORITE KEY**.
- 3) For programs P1 through P6, set **LEVEL** and **TIME** using the **+/- KEYS** and press **ENTER** after setting each value. For P7 (THR Zone), set **TARGET HEART RATE** and **TIME** using the **+/- KEYS** and press **ENTER** after setting each value.
- 4) After you have saved the last value (**TIME**) into memory by pressing **ENTER** in step 3, the **FAVORITE KEY** programming is complete and the LED inside the **FAVORITE KEY** will no longer flash. Press **START** to begin the program you just set.

***NOTE:** At any time, you may reset a **FAVORITE KEY** with a new program or different program settings by following the four steps listed above.

USING FAVORITE KEYS

- 1) After you have programmed a **FAVORITE KEY** as listed in the “SETTING FAVORITE KEYS” section, you may use the **FAVORITE KEY**. Press the desired **FAVORITE 1** or **FAVORITE 2** key.
- 2) Press **START** to begin the program.

***NOTE:** The **FAVORITE 1** and **FAVORITE 2** keys may only be used before starting a program. The keys will not function while in a program.

PROGRAM: REVERSE TRAIN (P6)

Program cues you to pedal forward and backwards for an exciting and challenging workout (**RESISTANCE** levels). Time-based goal with 16 difficulty levels to choose from.

Segment	WARM-UP				PROGRAM SEGMENTS												COOL-DOWN			
	1	2	3	4	5	6	7	8	9	10	11	12	13	14	15	16	17	18	19	20
Seconds	60	60	60	60	30	60	90	60	90	45	60	45	90	90	30	30	60	60	60	60
Direction	F	F	F	F	F	R	F	R	F	R	F	R	F	R	F	R	F	F	F	F
Level 1	1	1	1	2	2	2	2	1	2	2	1	2	2	1	2	2	2	1	1	1
Level 2	1	1	1	2	3	2	3	2	2	3	2	2	3	2	2	3	2	1	1	1
Level 3	1	1	1	2	4	3	4	2	3	4	2	3	4	2	3	4	2	1	1	1
Level 4	1	1	1	2	5	4	5	3	4	5	3	4	5	3	4	5	2	1	1	1
Level 5	1	2	2	2	6	5	6	4	5	6	4	5	6	4	5	6	2	2	2	1
Level 6	1	2	2	3	6	6	6	5	6	6	5	6	6	5	6	6	3	2	2	1
Level 7	1	2	2	3	7	6	7	6	6	7	6	6	7	6	6	7	3	2	2	1
Level 8	1	2	2	4	8	7	8	6	7	8	6	7	8	6	7	8	4	2	2	1
Level 9	1	1	1	2	9	8	9	7	8	9	7	8	9	7	8	9	2	1	1	1
Level 10	1	1	1	2	10	9	10	8	9	10	8	9	10	8	9	10	2	1	1	1
Level 11	2	2	2	2	10	10	10	9	10	10	9	10	10	9	10	10	2	1	1	1
Level 12	2	2	2	3	11	10	11	10	10	11	10	10	11	10	10	11	2	1	1	1
Level 13	2	3	3	4	12	11	12	10	11	12	10	11	12	10	11	12	2	2	2	1
Level 14	2	3	4	5	13	12	13	11	12	13	11	12	13	11	12	13	3	2	2	1
Level 15	2	4	5	6	14	13	14	12	13	14	12	13	14	12	13	14	3	2	2	1
Level 16	3	5	6	6	14	14	14	13	14	14	13	14	14	13	14	14	4	2	2	1

Warm up and cool-down last 4:00 minutes each

PROGRAM: THR ZONE (P7)

Automatically adjusts the resistance level to keep your heart rate in your desired range (see **THR ZONE CHART** on page 29).

60% OF MAX HEART RATE: Used for beginners and longer workouts. Lower intensity and longer duration helps burn fat more efficiently.

65% OF MAX HEART RATE: Used for beginner to intermediate users and mid to long range workouts. Lower intensity and longer duration helps burn fat more efficiently.

70% OF MAX HEART RATE: For intermediate users and mid range cardio workouts. While this range burns fat it really challenges the cardiovascular system and helps strengthen the heart.

75% OF MAX HEART RATE: For advanced users and short to mid range cardio workouts. Burns fat, tones muscles and challenges the heart.

80% OF MAX HEART RATE: For advanced users and short workouts. Burns fat, strengthens and tones muscles, and challenges the entire cardiovascular system.

Warm up and cool-down last 4:00 minutes each

PROGRAM: CUSTOM (P8)

Allows you to set your own **RESISTANCE** changes. Time-based goal.

HEART RATE

PULSE GRIPS

Place the palm of your hands directly on the grip pulse handlebars. Both hands must grip the bars for your heart rate to register. It takes 5 consecutive heart beats (15-20 seconds) for your heart rate to register. When gripping the pulse handlebars, do not grip tightly. Holding the grips tightly may elevate your blood pressure. Keep a loose, cupping hold. You may experience an erratic readout if consistently holding the grip pulse handlebars. Make sure to clean the pulse sensors to ensure proper contact can be maintained.

CONDITIONING GUIDELINES

ALWAYS CONSULT YOUR PHYSICIAN BEFORE BEGINNING AN EXERCISE PROGRAM.

HOW OFTEN? (Frequency of Workouts)

The American Heart Association recommends that you exercise at least 3 to 4 days per week to maintain cardiovascular fitness. If you have other goals such as weight or fat loss, you will achieve your goal faster with more frequent exercise. Whether it's 3 days or 6 days, remember that your ultimate goal should be to make exercise a lifetime habit. Many people are successful staying with a fitness program if they set aside a specific time of day to exercise. It doesn't matter whether it's in the morning before breakfast, during lunch hour or while watching the evening news. What's more important is that it's a time that allows you to keep a schedule, and a time when you won't be interrupted. To be successful with your fitness program, you have to make it a priority in your life. So decide on a time, pull out your day planner and pencil in your exercise times for the next month!

HOW LONG? (Duration of Workouts)

For aerobic exercise benefits, it's recommended that you exercise from between 24 and 60 minutes per session. But start slowly and gradually increase your exercise times. If you've been sedentary during the past year, it may be a good idea to keep your exercise times to as little as five minutes initially. Your body will need time to adjust to the new activity. If your goal is weight loss, a longer exercise session at lower intensities has been found to be most effective. A workout time of 48 minutes or more is recommended for best weight loss results.

HOW HARD? (Intensity of Workouts)

How hard you workout is also determined by your goals. If you use your machine to prepare for a 5K workout, you will probably work out at a higher intensity than if your goal is general fitness. Regardless of your long term goals, always begin an exercise program at low intensity. Aerobic exercise does not have to be painful to be beneficial! There are two ways to measure your exercise intensity. The first is by monitoring your heart rate (using the grip pulse handlebars), and the second is by evaluating your perceived exertion level (this is simpler than it sounds!).

PERCEIVED EXERTION LEVEL

A simple way to gauge your exercise intensity is to evaluate your perceived exertion level. While exercising, if you are too winded to maintain a conversation without gasping, you are working out too hard. A good rule of thumb is to work to the point of exhilaration, not exhaustion. If you cannot catch your breath, it's time to slow down. Always be aware of these warning signs of overexertion.

TARGET HEART RATE ZONE CHART

What is Target Heart Rate Zone?

Target Heart Rate Zone tells you the number of times per minute your heart needs to beat to achieve a desired workout effect. It is represented as a percentage of the maximum number of times your heart can beat per minute. Target Zone will vary for each individual, depending on age, current level of conditioning, and personal fitness goals. The American Heart Association recommends working-out at a Target Heart Rate Zone of between 60% and 75% of your maximum heart rate. A beginner will want to workout in the 60% range while a more experienced exerciser will want to workout in the 70-75% range. See chart for reference.

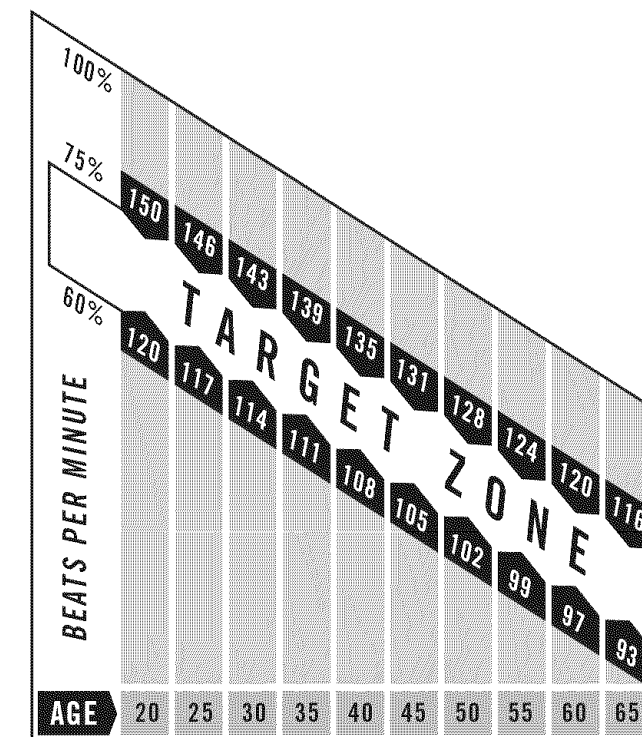

EXAMPLE:

For a 42-year-old user: Find age along the bottom of the chart (round to 40), follow age column up to the target zone bar. Results: 60% of maximum Hear Rate = 108 Beats Per Minute, 75% of maximum Heart Rate = 135 Beat Per Minute.

ALWAYS CONSULT YOUR PHYSICIAN BEFORE BEGINNING AN EXERCISE PROGRAM.

TIPS**STRETCHING****STRETCH FIRST**

Before using your product, it is best to take a few minutes to do a few gentle stretching exercises. Stretching prior to exercise will improve flexibility and reduce chances of exercise related injury. Ease into each of these stretches with a slow gentle motion. Do not stretch to the point of pain. Make sure not to bounce while doing these stretches.

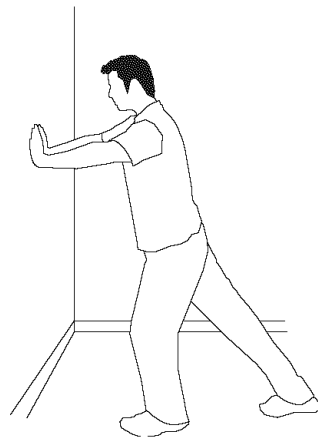
**1. STANDING CALF MUSCLE STRETCH**

Stand near a wall with the toes of your left foot about 18" from the wall, and the right foot about 12" behind the other foot. Lean forward, pushing against the wall with your palms. Keep your heels flat and hold this position for a count of 15 seconds. Make sure that you do not bounce while stretching. Repeat on the other side.

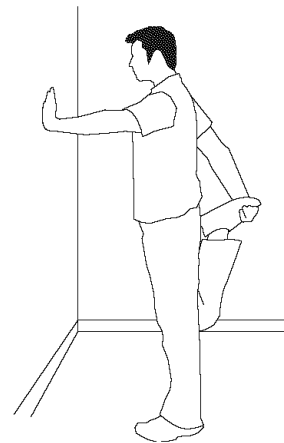
**2. STANDING QUADRICEPS STRETCH**

Using a wall to provide balance, grasp your left ankle with your left hand and hold your foot against the back of your thigh for 15 seconds. Repeat with your right ankle and hand.

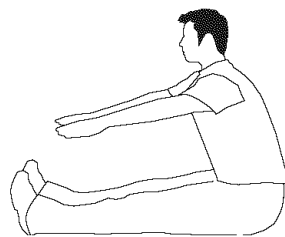
**3. SITTING HAMSTRING & LOWER BACK MUSCLE STRETCH**

Sit on the floor with your legs together and straight out in front of you. Do not lock your knees. Extend your fingers towards your toes and hold for a count of 15 seconds. Make sure that you do not bounce while stretching. Sit upright again. Repeat one time.

TIPS**THE IMPORTANCE OF WARM UP & COOL DOWN****WARM UP**

The first 2 to 5 minutes of a workout should be devoted to warming up. The warm-up will limber your muscles and prepare them for more strenuous exercise. Make sure that you warm-up on your product at a slow pace. The warm up should gradually bring your heart rate into your Target Heart Rate Zone.

COOL DOWN

Never stop exercising suddenly! A cool-down period of 3-5 minutes allows your heart to readjust to the decreased demand. Make sure that your cool down period consists of a very slow pace to allow your heart rate to lower. After the cool-down, repeat the stretching exercises listed above to loosen and relax your muscles.

TIPS**ACHIEVING YOUR FITNESS GOALS**

An important step in developing a long term fitness program is to determine your goals. Is your primary goal for exercising to lose weight? Improve muscle? Reduce stress? Prepare for the spring racing schedule? Knowing what your goals are will help you develop a more successful exercise program. Below are some common exercise goals:

- Weight Loss - lower intensity, longer duration workouts
- Improve Body Shape and Tone - interval workouts, alternate between hi and low intensities
- Increased Energy Level - more frequent daily workouts
- Improved Sports Performance - high intensity workouts
- Improved Cardiovascular Endurance - moderate intensity, longer duration workouts

If possible try to define your personal goals in precise, measurable terms, and then put your goals in writing. The more specific you can be, the easier it will be to track your progress. If your goals are long term, divide them up into monthly and weekly segments. Longer term goals can lose some of the immediate motivation benefits. Short term goals are easier to achieve. Your console provides you with several readouts that can be used to record your progress. You can track Distance, Calories or Time.

KEEPING AN EXERCISE DIARY

To make your personal exercise log book, photocopy the weekly and monthly log sheets, which are located on the following pages, or you can print them off of your computer by going to:

www.horizonfitness.com/guides/weeklylog.pdf

www.horizonfitness.com/guides/monthlylog.pdf

As your fitness improves, you can look back and see how far you've come!

WEEKLY LOG SHEETS

WEEK #		WEEKLY GOAL				COMMENTS
DAY	DATE	DISTANCE	CALORIES	TIME		
SUNDAY						
MONDAY						
TUESDAY						
WEDNESDAY						
THURSDAY						
FRIDAY						
SATURDAY						
WEEKLY TOTALS :						

WEEK #		WEEKLY GOAL				COMMENTS
DAY	DATE	DISTANCE	CALORIES	TIME		
SUNDAY						
MONDAY						
TUESDAY						
WEDNESDAY						
THURSDAY						
FRIDAY						
SATURDAY						
WEEKLY TOTALS :						

WEEK #		WEEKLY GOAL				COMMENTS
DAY	DATE	DISTANCE	CALORIES	TIME		
SUNDAY						
MONDAY						
TUESDAY						
WEDNESDAY						
THURSDAY						
FRIDAY						
SATURDAY						
WEEKLY TOTALS :						

MONTHLY LOG SHEETS

MONTH		MONTHLY GOAL		
WEEK #	DISTANCE	CALORIES	TIME	
MONTHLY TOTALS :				

MONTH		MONTHLY GOAL		
WEEK #	DISTANCE	CALORIES	TIME	
MONTHLY TOTALS :				

MONTH		MONTHLY GOAL		
WEEK #	DISTANCE	CALORIES	TIME	
MONTHLY TOTALS :				

TROUBLESHOOTING

Your Horizon Fitness elliptical is designed to be reliable. However, if you do experience problems with your elliptical, please reference the troubleshooting guide listed below.

PROBLEM: The console does not light up.

SOLUTION: Verify the following:

- The outlet the machine is plugged into is functional. Double check that the breaker has not tripped.
- The correct adapter is being used. Only use an adapter intended for Horizon Fitness Ellipticals.
- The adapter is not pinched or damaged and is properly plugged into the outlet AND the machine.
- The power switch is turned to the ON position (may not apply to all models).
- Turn off the machine and unplug power cord. Remove the console and check that all connections to the console are secure and not damaged or pinched.

NOTE: If your console uses batteries, they may need to be replaced.

PROBLEM: The console lights up but the Time/RPM's do not count.

SOLUTION: Verify the following:

- Turn off machine and unplug power cord. Remove the console and check that all connections to the console are secure and not damaged or pinched.
- If doing the above does not fix the problem, the speed sensor and/or magnet may have become dislodged or damaged.

PROBLEM: The resistance levels seem to be incorrect, seeming too hard or too easy.

SOLUTION: Verify the following:

- The correct adapter is being used. Only use an adapter intended for Horizon Fitness Ellipticals.
- Reset the console and allow the resistance to reset to the default position. Restart and retry the resistance levels.

PROBLEM: The roller wheels appear to be leaving particles on the guide rails.

SOLUTION: This is considered normal wear of the elliptical wheels.

To remove, simply wipe off the roller wheels and guide rails with a damp cloth.

PROBLEM: The elliptical makes a squeaking or chirping noise.

SOLUTION: Verify the following:

- The elliptical is on a level surface.
- Loosen all bolts attached during the assembly process, grease the threads, and tighten again.

HEART RATE TROUBLESHOOTING

PROBLEM: There is no heart rate reading.

SOLUTION: Remove the console and verify that the heart rate cables are attached properly, making sure that the cables are securely inserted into the console.

YOU MAY EXPERIENCE AN ERRATIC READOUT UNDER THE FOLLOWING CONDITIONS:

- Gripping the heart rate handlebars too tight. Try to maintain moderate pressure while holding onto the heart rate handlebars.
- Constant movement and vibration due to constantly holding the heart rate grips while exercising.
- When you are breathing heavily during a workout.
- When your hands are constricted by wearing a ring.
- When your hands are dry or cold. Try moistening your palms or rubbing them together to warm.
- Anyone with heavy arrhythmia.
- Anyone with arteriosclerosis or peripheral circulation disorder.
- Anyone whose palm skin is especially thick.

NOTE: Outside interference sources such as computers, motors and fluorescent lights may cause the heart rate reading to be erratic. Check your exercise environment for sources of interference such as high power lines, large motors, etc.

If the above troubleshooting section does not remedy the problem, discontinue use, turn the power off, and contact Sears for service at 1-800-4-MY-HOME®.

The following information may be asked of you when you call. Please have these items readily available:

- Model Name
- Serial Number

In order for a technician to service your elliptical, you may be asked detailed questions about the symptoms that are occurring. Some troubleshooting questions that may be asked are:

- How long has this problem been occurring?
- Does this problem occur with every use? With every user?
- If you are hearing a noise, does it come from the front, back or inside? What kind of noise is it (thumping, grinding, squeaking, chirping etc.)?
- If you are having a resistance problem what is occurring? Is the resistance always too hard or too easy? Does the resistance respond when pushing the buttons on the console? Does the resistance constantly cycle through the levels during the workout?
- Has the machine been maintained per the maintenance schedule?
- Does the problem occur when using the handlebars? Without using the handlebars?

Answering these and other questions will give the technicians the ability to send proper replacement parts and the service necessary to get you and your Horizon Fitness elliptical running again!

COMMON PRODUCT QUESTIONS

ARE THE SOUNDS MY ELLIPTICAL MAKES NORMAL?

Our ellipticals are some of the quietest available because they use belt drives and friction free magnetic resistance. We use the highest grade bearings and belts to minimize noise. However, because the resistance system itself is so quiet, you will occasionally hear other slight mechanical noises. Unlike older, louder technologies, there are no fans, friction belts, or alternator noises to mask these sounds on our ellipticals. These mechanical noises, which may or may not be intermittent, are normal and are caused by the transfer of significant amounts of energy to a rapidly spinning flywheel. All bearings, belts and other rotating parts will generate some noise which will transmit through the casing and frame. It is also normal for these sounds to change slightly during a workout and over time because of thermal expansion of the parts.

WHY IS THE ELLIPTICAL I HAD DELIVERED LOUDER THAN THE ONE AT THE STORE?

All fitness products seem quieter in a large store showroom because there is generally more background noise than in your home. Also, there will be less reverberation on a carpeted concrete floor than on a wood overlay floor. Sometimes a heavy rubber mat will help reduce reverberation through the floor. If a fitness product is placed close to a wall, there will be more reflected noise.

HOW LONG WILL THE DRIVE BELT LAST?

The computer modeling we have done indicated virtually thousands of maintenance free hours. Belts are now commonly used in far more demanding applications such as motorcycle drives.

CAN I MOVE THE TRAINER EASILY ONCE IT IS ASSEMBLED?

Your elliptical has a pair of transport wheels built into the front legs. It is easy to move your elliptical by rolling it on the front transport wheels. It is important that you place your elliptical in a comfortable and inviting room. Your elliptical is designed to use minimal floor space. Many people will place their ellipticals facing the TV or a picture window. If at all possible, avoid putting your elliptical in a unfinished basement. To make exercise a desirable daily activity for you, the elliptical should be in a comfortable setting.

CAN I PEDAL BACKWARDS ON MY ELLIPTICAL?

Your elliptical allows you to pedal both forward and backwards to exercise and strengthen a wider range of muscles.

MAINTENANCE

WHAT KIND OF ROUTINE MAINTENANCE IS REQUIRED?

We use sealed bearings throughout our ellipticals so lubrication is not needed. The most important maintenance step is to simply wipe your perspiration off the trainer after each use.

HOW DO I CLEAN MY ELLIPTICAL?

Clean with soap and water cleaners only. Never use solvents on plastic parts.

Cleanliness of your elliptical and its operating environment will keep maintenance problems and service calls to a minimum. For this reason, Horizon Fitness recommends that the following preventive maintenance schedule be followed.

AFTER EACH USE (DAILY)

Turn off the elliptical by unplugging the power cord from the wall outlet

- Wipe down the elliptical with a damp cloth. Never use solvents, as they can cause damage to the elliptical.
- Inspect the power cord. Replace the power cord if damaged.
- Make sure the power cord is not underneath the elliptical or in any other area where it can become pinched or cut.



To remove power from the elliptical, the power cord must be disconnected from the wall outlet.

WEEKLY

Clean underneath the elliptical, following these steps:

- Turn off the elliptical
- Move the elliptical to a remote location.
- Wipe or vacuum any dust particles or other objects that may have accumulated underneath the elliptical.
- Return the elliptical to its previous position.

EVERY MONTH

- Inspect all assembly bolts and pedals on the machine for proper tightness.
- Clean any debris off of the pedal arm wheels and guide rails.

LIMITED WARRANTY

One Year Limited Warranty

When assembled, operated and maintained according to all instructions supplied with the product, if this Elliptical machine fails due to a defect in material or workmanship within one year from the date of purchase, call 1-800-4-MY-HOME® to arrange for free repair.

Additional Limited Warranty on Specific Parts

From the date of purchase for the time periods listed below, the following specific parts will be supplied free of charge if they fail due to a defect in material or workmanship. After the first year from the date of purchase, you pay for labor to have them installed.

- *Seven Years: Brake*
- *Lifetime: Frame*

All warranty coverage is void if this product is ever used for other than private household purposes.

This warranty gives you specific legal rights, and you may also have other rights which vary from state to state.

Sears, Roebuck and Co., Hoffman Estates, IL 60179

Get it fixed, at your home or ours!

Your Home

For repair – **in your home** – of **all** major brand appliances, lawn and garden equipment, or heating and cooling systems, **no matter who made it, no matter who sold it!**

For the replacement parts, accessories and owner's manuals that you need to do-it-yourself.

For Sears professional installation of home appliances and items like garage door openers and water heaters.

1-800-4-MY-HOME® (1-800-469-4663)

Call anytime, day or night (U.S.A. and Canada)

www.sears.com www.sears.ca

Our Home

For repair of carry-in items like vacuums, lawn equipment, and electronics, call or go on-line for the location of your nearest

Sears Parts & Repair Service Center

1-800-488-1222

Call anytime, day or night (U.S.A. only)

www.sears.com

To purchase a protection agreement (U.S.A.) or maintenance agreement (Canada) on a product serviced by Sears:

1-800-827-6655 (U.S.A.)

1-800-361-6665 (Canada)

Para pedir servicio de reparación a domicilio, y para ordenar piezas:

1-888-SU-HOGAR®

(1-888-784-6427)

www.sears.com

Au Canada pour service en français:

1-800-LE-FOYER^{MC}

(1-800-533-6937)

www.sears.ca



© Registered Trademark / TM Trademark / SM Service Mark of Sears Brands, LLC

© Marca Registrada / TM Marca de Fábrica / SM Marca de Servicio de Sears Brands, LLC

^{MC} Marque de commerce / ^{MD} Marque déposée de Sears Brands, LLC

© Sears Brands, LLC