

Operator's Manual

CRAFTSMAN®

3.0 HP (Max. Developed)

10" Inch Blade

5000 R.P.M.

TABLE SAW

Model No.

137.218041

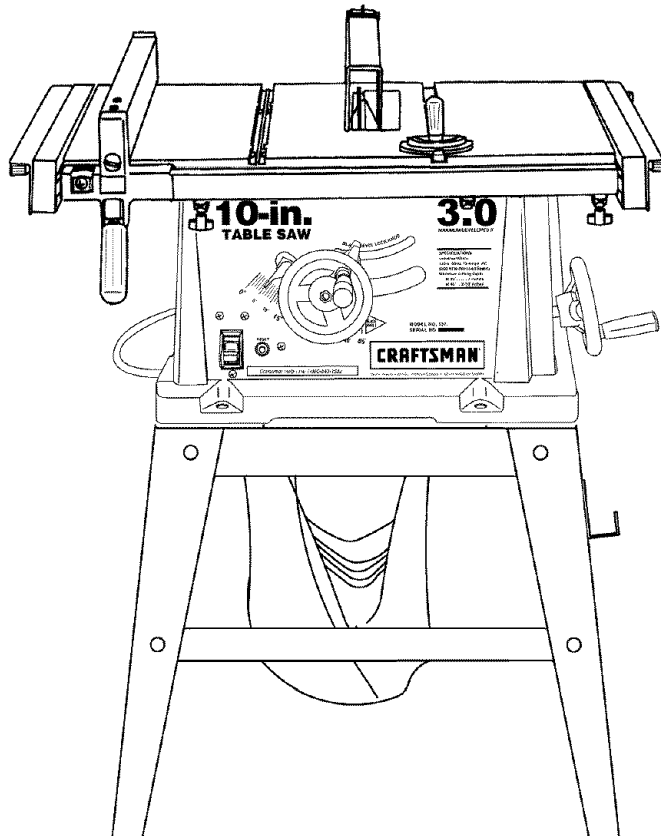

CAUTION:

Before using this Table Saw, read this manual and follow all its Safety Rules and Operating Instructions. Failure to heed the warnings in this manual can result in serious injury to the user.

- Safety Instructions
- Installation
- Operation
- Maintenance
- Parts List

Customer Help Line
1-800-843-1682

Sears, Roebuck and Co., Hoffman Estates, IL 60179 USA

Visit our Craftsman website: www.sears.com/craftsman

Part No. 137218041001

TABLE OF CONTENTS

SECTION	PAGE	SECTION	PAGE
Warranty	2	Know Your Table Saw.....	8
Product Specifications	2	Assembly and Adjustments.....	9
Power Tool Safety	3	Operation.....	16
Table Saw Safety.....	4	Maintenance	20
Electrical Requirements and Safety.....	5	Troubleshooting Guide.....	21
Accessories and Attachments.....	6	Parts List.....	22
Tools Needed For Assembly.....	6	Push Stick Plan	30
Carton Contents	6		

WARRANTY

FULL ONE YEAR WARRANTY

If this Table Saw fails due to a defect in material or workmanship within one year of date of purchase, Sears will at its option repair or replace it free of charge.

Return this Table Saw to a Sears Service Center for repair, or to place of purchase for replacement.

This warranty gives you specific legal rights, and you may also have other rights which may vary from state to state.

Sears, Roebuck and Co., Dept. 817 WA, Hoffman Estates, IL 60179

⚠ WARNING

Some dust created by power sanding, sawing, grinding, drilling and other construction activities contains chemicals known to the state of California to cause cancer, birth defects or other reproductive harm. Some examples of these chemicals are:

- Lead from lead-based paints
- Crystalline silica from bricks, cement and other masonry products
- Arsenic and chromium from chemically treated lumber

Your risk from these exposures varies, depending on how often you do this type of work. To reduce your exposure to these chemicals, work in a well-ventilated area and work with approved safety equipment such as dust masks that are specially designed to filter out microscopic particles.

PRODUCT SPECIFICATIONS

MOTOR

HP(Maximum developed).....	3.0
Type	Universal
Amps	15
Voltage	120
Hz	60
RPM (no load).....	5000
Overload Protection.....	YES

SAW

Table Size.....	26-7/64" x 17-5/8"
Table Extensions.....	Yes - Three
Extension Fence Capacity...	24" Right & Left
Blade Size.....	10"
Rip Fence	YES
Miter Gauge.....	YES
Maximum Cut Depth @ 90°..	3"
Maximum Cut Depth @ 45°..	2-1/2"
Maximum Diameter Dado	6"
Maximum Dado Cut Width...	1/2"
Net Weight.....	52 LBS

⚠ WARNING

To avoid electrical hazards, fire hazards or damage to the table saw, use proper circuit protection.

This table saw is wired at the factory for 110-120 Volt operation. It must be connected to a 110-120 Volt / 15 Ampere time delay fuse or circuit breaker. To avoid shock or fire, replace power cord immediately if it is worn, cut or damaged in any way.

Before using your table saw, it is critical that you read and understand these safety rules. Failure to follow these rules could result in serious injury to you or damage to the table saw.

POWER TOOL SAFETY

⚠ WARNING Before using your table saw, it is critical that you read and understand these safety rules. Failure to follow these rules could result in serious injury or damage to the table saw.

Good safety practices are a combination of common sense, staying alert and understanding how to use your power tool. To avoid mistakes that could cause serious injury, do not plug in your power tool until you have read and understood the following safety rules:

1. **READ** and become familiar with this entire Operator's Manual. **LEARN** the tool's applications, limitations and possible hazards.
2. **⚠ WARNING** Look for this symbol that identifies important safety precautions. It indicates a potentially hazardous situation where your safety is involved. You must adhere to the safety instructions to avoid serious injury or possible death.
3. **⚠ WARNING** Look for this symbol that identifies important safety precautions. It indicates an imminently hazardous situation where your safety is involved. You must adhere to the safety instructions to avoid serious injury or possible death.
4. **NEVER OPERATE THIS MACHINE WITHOUT THE SAFETY GUARD IN PLACE FOR ALL THROUGH-SAWING OPERATIONS.**
5. **DO NOT USE IN DANGEROUS ENVIRONMENTS** such as damp or wet locations or exposure to rain. Keep work area well lit.
6. **DO NOT** use power tools in the presence of flammable liquids or gases.
7. **KEEP WORK AREA CLEAN.** Cluttered areas and benches invite accidents.
8. **KEEP CHILDREN AWAY.** All visitors should be kept at a safe distance from the work area.
9. **DO NOT FORCE THE TOOL.** It will do the job better and safer at the rate for which it was designed.
10. **USE THE RIGHT TOOL.** Don't force the tool or attachment to do a job for which it is not designed.
11. **WEAR PROPER APPAREL.** **DO NOT** wear loose clothing, gloves, neckties, rings, bracelets or other jewelry which may get caught in moving parts. Non-slip footwear is recommended. Wear protective hair covering to contain long hair.
12. **WEAR A FACE MASK OR DUST MASK.** Sawing, cutting and sanding operations produce dust.
13. **DISCONNECT TOOLS** before servicing and when changing accessories such as blades, cutters, etc.
14. **REDUCE THE RISK OF UNINTENTIONAL STARTING.** Make sure the switch is in the OFF position before plugging into the power supply. **USE ONLY RECOMMENDED ACCESSORIES.** Consult the Operator's Manual for recommended accessories. The use of improper accessories may cause injury to you or damage to the tool.
15. **REMOVE ADJUSTING KEYS AND WRENCHES.** Form the habit of checking to see that keys and adjusting wrenches are removed from the tool before turning ON.
16. **NEVER LEAVE TOOL RUNNING UNATTENDED. TURN THE POWER "OFF".** Do not leave the tool before it comes to a complete stop.
17. **NEVER STAND ON TOOL.** Serious injury could occur if the tool is tipped or if the cutting tool is unintentionally contacted.
18. **DO NOT OVERREACH.** Keep proper footing and balance at all times.
19. **MAINTAIN TOOLS WITH CARE.** Keep tools sharp and clean for most efficient and safest performance. Follow instructions for lubricating and changing accessories.
20. **CHECK FOR DAMAGED PARTS.** Before further use of the tool, a guard or other part that is damaged should be carefully checked to ensure it will operate properly and perform its intended function. Check for alignment of moving parts, binding of moving parts, mounting and any other conditions that may affect its safe operation. A guard or other part that is damaged should be properly repaired or replaced.
21. **MAKE WORKSHOP CHILD PROOF** with padlocks, master switches or by removing starter keys.
22. **DO NOT** operate the tool if you are under the influence of any drugs, alcohol or medication that could impair your ability to use the tool safely.
23. **USE A DUST COLLECTION SYSTEM** wherever possible. Dust generated from certain materials can be hazardous to your health and in some cases, a fire hazard. Always operate the power tool in a well-ventilated area with adequate dust removal.
24. **ALWAYS WEAR EYE PROTECTION.** Any power tool can throw foreign objects into your eyes which could cause permanent eye damage. **ALWAYS** wear safety goggles (not glasses) that comply with ANSI safety standard Z87.1. Everyday glasses have only impact resistant lenses. They **ARE NOT** safety glasses.
NOTE: Glasses or goggles not in compliance with ANSI Z87.1 could cause serious injury when they break.
25. **DIRECTION OF FEED.** Feed work into a blade or cutter against the direction of rotation of the blade or cutter only.
26. **DO NOT AUTHORIZE ADDITIONAL USERS** to operate this power tool without the accompanying operators manual for which the user must read & understand.

TABLE SAW SAFETY

1. **ALWAYS USE SAW BLADE GUARD**, splitter and anti-kickback pawls for every operation for which they can be used, including through-sawing. Through-sawing operations are those in which the blade cuts completely through the workpiece when ripping or cross-cutting.
2. **ALWAYS HOLD WORK FIRMLY** against the miter gauge or rip fence.
3. **USE A PUSH STICK** when required. Always use a push stick when ripping narrow stock. Refer to ripping instructions in this Operator's Manual where the push stick is covered in detail. A pattern for making your own push stick is included on page 30.
4. **NEVER PERFORM ANY OPERATION "FREE HAND"**, which means using only your hands to support or guide the workpiece. Always use either the fence or the miter gauge to position and guide the work.

DANGER: FREEHAND CUTTING IS THE MAJOR CAUSE OF KICK-BACK & FINGER/HAND AMPUTATIONS.
5. **NEVER STAND** or have any part of your body in line with the path of the saw blade. Keep your hands out of the saw blade path.
6. **NEVER REACH** behind or over the cutting tool for any reason.
7. **NEVER** use a rip fence when cross cutting.
8. **DO NOT USE** a molding head with this saw.
9. **FEED WORK INTO THE BLADE** against the direction of rotation only.
10. **NEVER** use the rip fence as a cut-off gauge when cross-cutting.
11. **NEVER ATTEMPT TO FREE A STALLED SAW BLADE** without first turning the saw OFF. Turn power switch OFF and disconnect the plug from the power source immediately to prevent motor damage & before removing material
12. **PROVIDE ADEQUATE SUPPORT** to the rear and the sides of the saw table for long or wide workpieces.
13. **AVOID KICKBACKS** (work thrown back towards you) by keeping the blade sharp, the rip fence parallel to the saw blade and by keeping the splitter, anti-kickback pawls and guards in place and functioning. Do not release work before it has passed all the way past the saw blade & is off the table. Do not rip work that is twisted, warped or does not have a straight edge to guide it along the fence.
14. **AVOID AWKWARD OPERATIONS** and hand positions where a sudden slip could cause your hand to move into the saw blade.
15. **NEVER USE SOLVENTS** to clean plastic parts. Solvents could possibly dissolve or otherwise damage the material. Only a soft damp cloth should be used to clean plastic parts.
16. **MOUNT** your table saw on a bench or stand before performing any cutting operations. Refer to ASSEMBLY AND ADJUSTMENTS on page 9.
17. **NEVER CUT METALS** or materials which may make hazardous dust.
18. **ALWAYS USE IN WELL-VENTILATED AREA.** Remove sawdust frequently. Clean out sawdust from the interior of the saw to prevent a potential fire hazard. Attach a vacuum to the dust port for additional sawdust removal.
19. **NEVER LEAVE THE SAW** running unattended. Do not leave the saw until it comes to a complete stop.
20. **FOR** proper operation follow the instructions in this Operator's Manual. Failure to provide sawdust fall-through and removal hole will allow sawdust to build up in the motor area resulting in a fire hazard and potential motor damage (see page 10 for details).
21. **DO NOT AUTHORIZE ADDITIONAL USERS** to operate this power tool without the accompanying operators manual for which the user must read and understand.
22. **THE REAR OF THE TABLE INSERT MUST BE FLUSH TO THE TABLE** during all sawing operations. Two different inserts are provided for regular through-sawing operations and dado cutting where a rubber adjusting spacer is provided under the rear of the insert for this purpose.
23. **DO NOT USE A DADO BLADE LARGER THAN 6"** in diameter and 1/2" in width.

ELECTRICAL REQUIREMENTS AND SAFETY

POWER SUPPLY REQUIREMENTS

⚠ WARNING

To avoid electrical hazards, fire hazards or damage to the table saw, use proper circuit protection. Always use a separate electrical circuit for your tools. This power tool is wired at the factory for 120V operation. Connect it to a 120V, 15 Amp circuit and use a 15 Amp time delay fuse or circuit breaker. To avoid shock or fire, replace the cord immediately if it is worn, cut or damaged in any way.

EXTENSION CORD REQUIREMENTS

⚠ WARNING

Any extension cord must be GROUNDED for safe operation.

MINIMUM GAUGE FOR EXTENSION CORDS (AWG type / 120 Volt only)					
Ampere Rating		Total length in feet			
More Than	Not More Than	25'	50'	100'	150'
0	6	18	16	16	14
6	10	18	16	14	12
10	12	16	16	14	12
12	16	14	12	Not Applicable	

GUIDELINES FOR EXTENSION CORDS

Any extension cord used for power tools MUST be grounded (3 wire with two flat prongs and one round ground prong).

Make sure the extension cord is in good condition. When using an extension cord, make sure you use one heavy enough to carry the current the tool will draw. An undersized cord will cause a drop in line voltage resulting in loss of power and overheating. The table above shows the correct size to use according to extension cord length and nameplate ampere rating. If in doubt, use the next heavier gauge cord. The smaller the gauge number the heavier the cord.

NOTE: THE 12 TO 16 AMP RATING IS CORRECT FOR THIS TOOL. IT IS HIGHLIGHTED IN THE TABLE ABOVE.

Be sure your extension cord is properly wired and in good condition. Always replace a damaged extension cord or have it repaired by a qualified person before using it. Protect your extension cords from sharp objects, excessive heat and damp or wet areas.

Before connecting the saw to the extension cord, make sure the saw switch is turned OFF.

GROUNDING INSTRUCTIONS

IN THE EVENT OF A MALFUNCTION OR BREAKDOWN, grounding provides a path of least resistance for electric current and reduces the risk of electric shock. This saw is equipped with an electric cord that has an equipment grounding conductor and a grounding plug. The plug MUST be plugged into a matching receptacle that is properly installed and grounded in accordance with ALL local codes and ordinances.

DO NOT MODIFY THE PLUG PROVIDED. If it will not fit the receptacle, have the proper receptacle installed by a qualified electrician.

IMPROPER CONNECTION of the equipment grounding conductor can result in risk of electric shock. The conductor (wire) with the green insulation (with or without yellow stripes) is the equipment grounding conductor. If repair or replacement of the electric cord or plug is necessary, DO NOT connect the equipment grounding conductor to a live terminal.

CHECK with a qualified electrician or service personnel if you do not completely understand the grounding instructions, or if you are not sure the saw is properly grounded.

USE ONLY 3-WIRE EXTENSION CORDS THAT HAVE 3-PRONG GROUNDING PLUGS AND 3-POLE GROUNDING RECEPTACLES THAT ACCEPT THE SAW'S PLUG. REPAIR OR REPLACE DAMAGED OR WORN CORDS IMMEDIATELY.

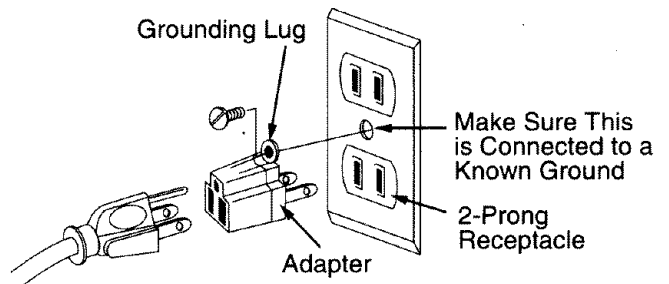
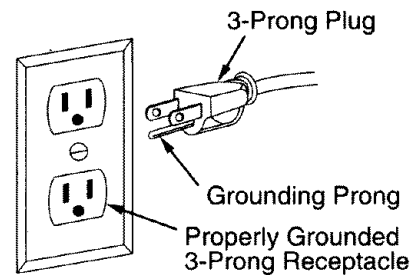

ACCESSORIES AND ATTACHMENTS

RECOMMENDED ACCESSORIES

▲ WARNING

Visit your Sears Hardware Department or see the Craftsman Power and Hand Tools Catalog to purchase recommended accessories for this power tool.

▲ WARNING

To avoid the risk of personal injury:

- Do not use adjustable (wobble) type dados or carbide tipped dado blades.
- Maximum dado width is 1/2".
- Do not use a dado with a diameter larger than 6".
- Do not use molding head set with this saw.
- Do not modify this power tool or use accessories not recommended by Sears.

TOOLS NEEDED FOR ASSEMBLY

TOOLS NEEDED



13mm Wrench



Phillips screwdriver



Straight edge

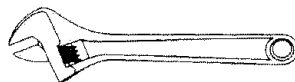

Adjustable wrench

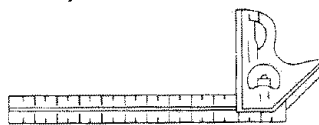

Combination square

CARTON CONTENTS

UNPACKING AND CHECKING CONTENTS

- For missing or damaged parts on initial purchase, call 800-843-1682
- To order parts, call 800-366-7278

Separate all parts from packing materials. Check each part with the illustration on the next page and the "Table of Loose Parts" to make certain all items are accounted for, before discarding any packing material.

▲ WARNING

If any part is missing or damaged, do not attempt to assemble the table saw, plug in the power cord, or turn the switch ON until the missing or damaged part is obtained and is installed correctly.

TABLE OF LOOSE PARTS

<u>ITEM</u>	<u>DESCRIPTION</u>	<u>QUANTITY</u>
A.	Table saw assembly	1
B.	Blade guard and splitter	1
C.	Bolt, flat washer, toothed washer, Oval washer, spring washer	1 each
D.	Rip fence, handle & nut	1
E.	Hand wheels	2
F.	Dome nuts	2
G.	Hand wheel handle	2
H.	Dado table insert	1
I.	Miter gauge	1
J.	Hex key	2
K.	Blade wrenches	2
L.	Table extension fences	2
M.	Locking Knobs	4
N.	Blade	1
O.	Dust chute	1
P.	Dust bag	1

STAND

Q.	Short Upper Support	2
R.	Long Upper Support	2
S.	Short Bottom Support	2
T.	Long Bottom Support	2
U.	Leg	4
V.	Stand mounting hardware bag	1

NOTE: To make assembly easier, keep contents of box together. Apply a coat of automobile wax to the table. Wipe all parts thoroughly with a clean dry cloth. This will reduce friction when pushing the workpiece.

UNPACKING YOUR TABLE SAW:

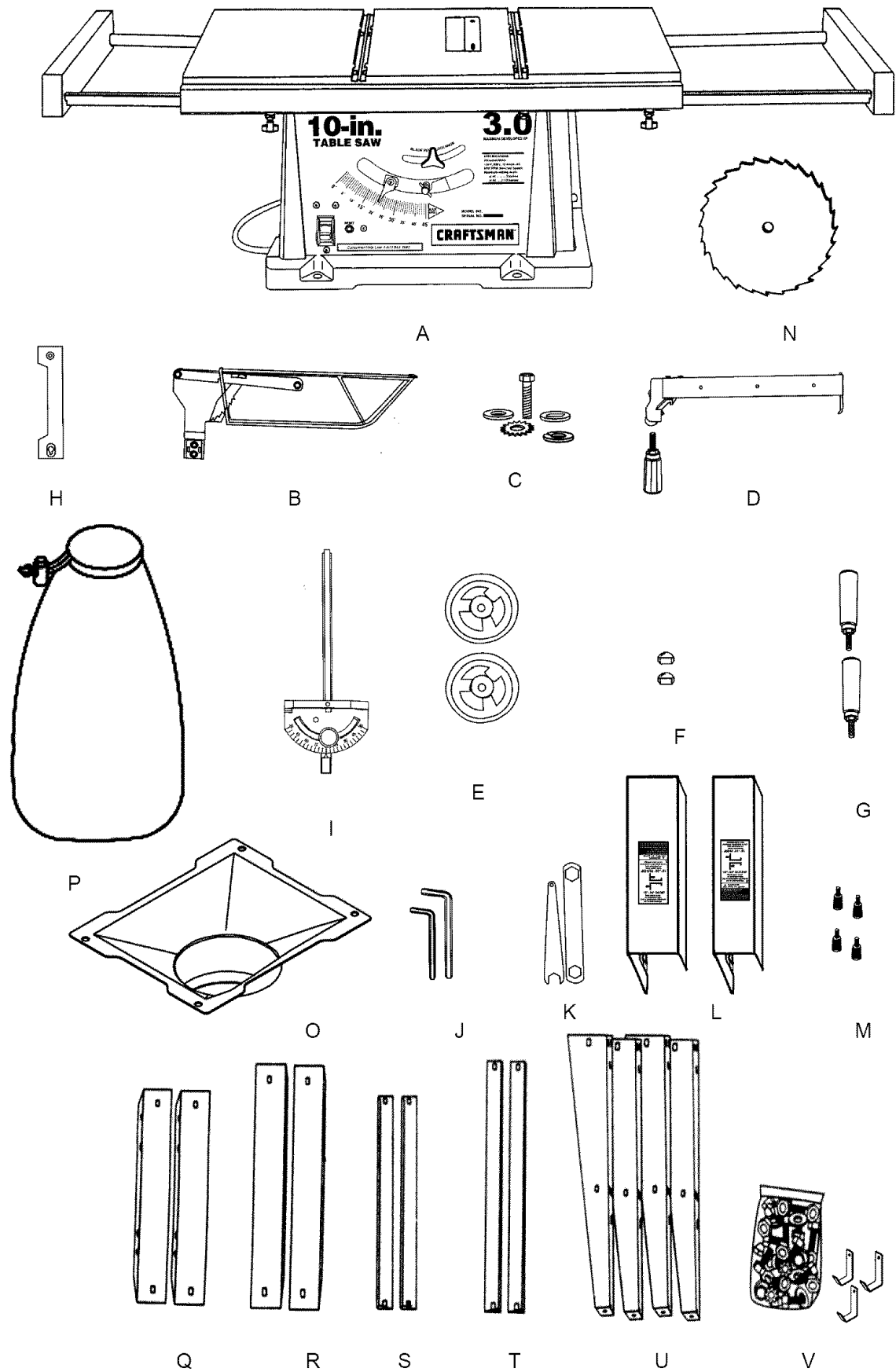

KNOW YOUR TABLE SAW

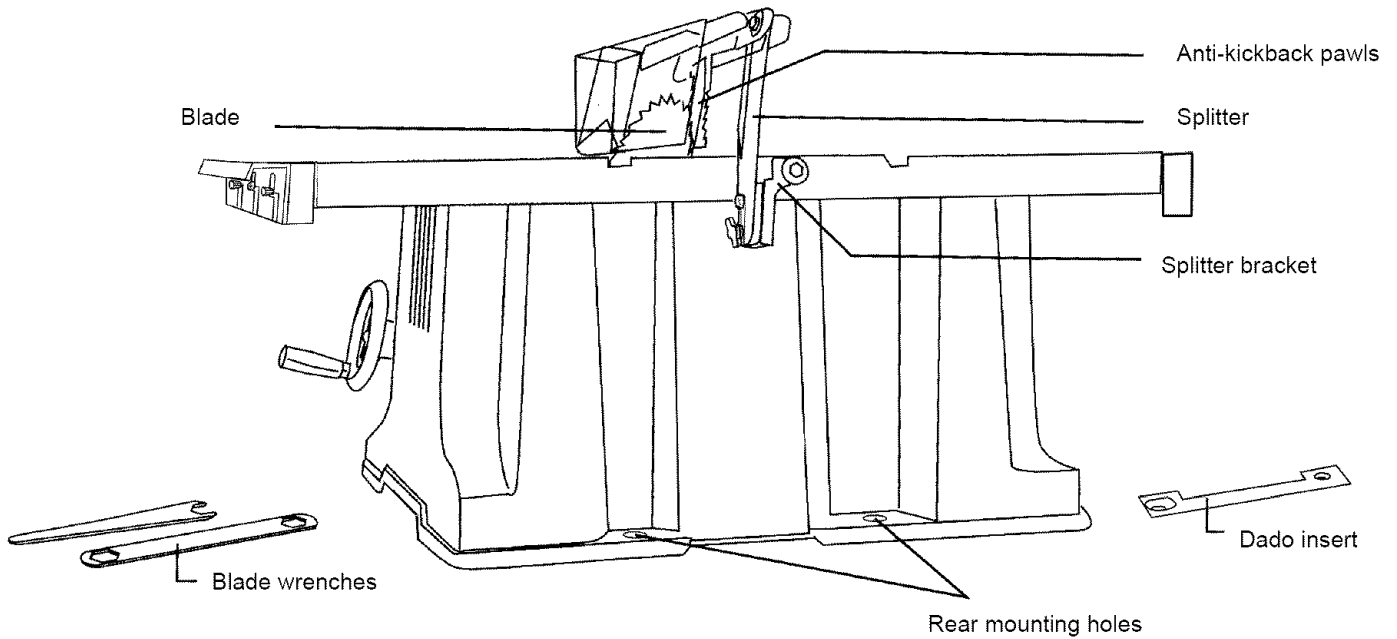
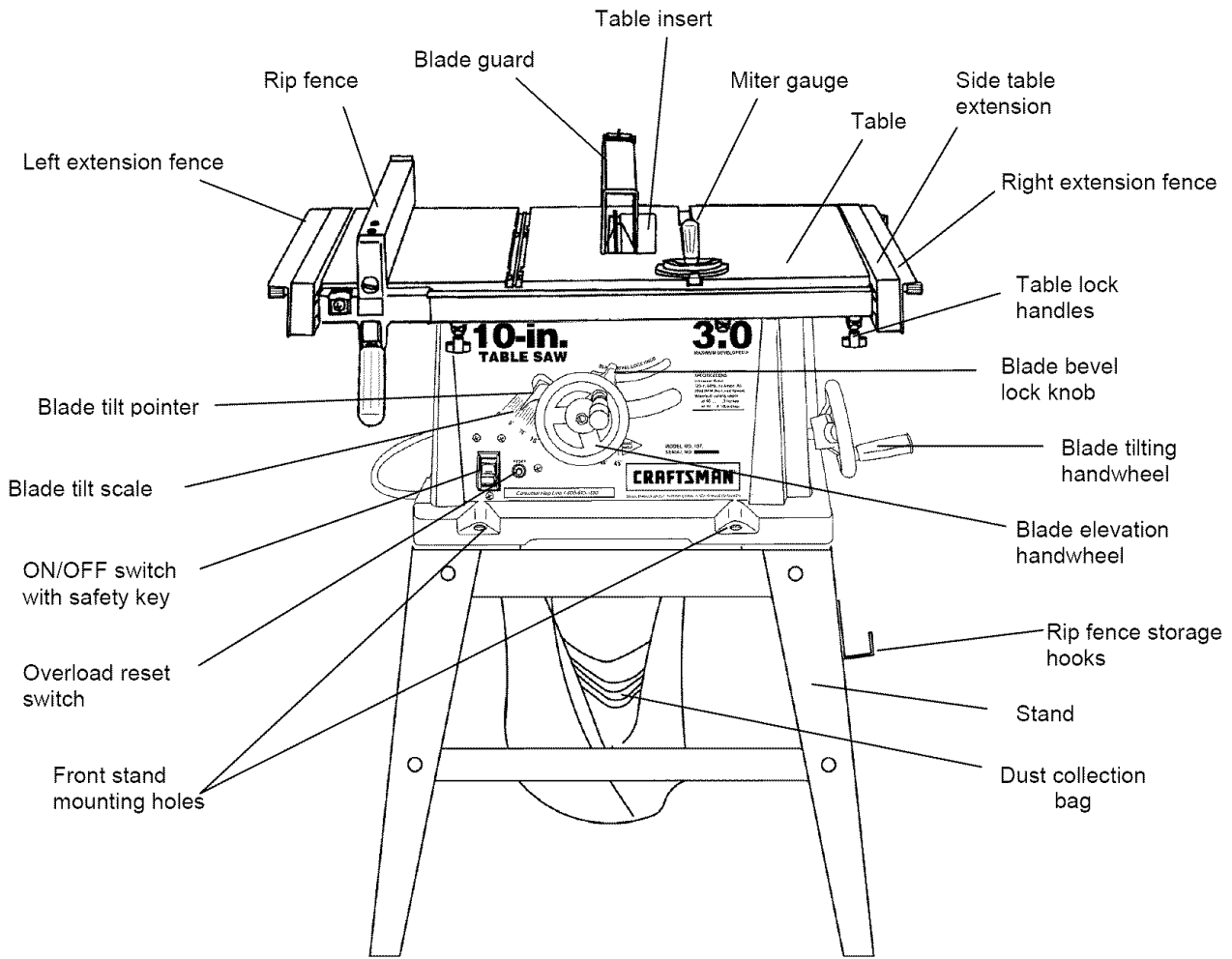

ASSEMBLY AND ADJUSTMENTS

Assemble stand (Fig. A)

1. Unpack all parts and group by type and size (Fig. A). Refer to parts list for quantities.
2. Attach one long upper support (12) to top of leg (1) using one square neck bolt (2) and nut (8).
- NOTE:** Snug bolts until stand is properly aligned (see step #9 before tightening).
3. Attach other end of long upper support to top of another leg using one square neck bolt and nut.
4. Attach one long bottom support (3) to center of each leg using square neck bolts and nuts. This completes the front frame section.
5. Assemble rear frame section in exactly the same way.
6. Join front and rear frame assemblies using two short upper supports (9) and two short bottom supports (13), square neck bolts and nuts.
7. Insert large hex head bolt (4) into rubber foot (5) and insert into bottom of leg. Fasten with washer (6) and nut (7). Repeat for each leg.
8. Attach one hook (14) to the left of the stand. Attach two hooks to the right of the stand for the rip fence storage.
9. Place stand on level surface and adjust so all legs are contacting the floor and are at similar angles to the floor. Tighten all bolts.
- NOTE:** Stand should not rock after all bolts are tightened.

Assemble table saw to stand (Fig. A, B)

1. Place protective corrugated cardboard or old blanket on floor to protect the saw table surface.
2. Place the saw up-side down on the protective material (Fig. B).
3. Position the dust chute between the stand and saw.
4. Position the stand up-side down on the saw base.
- NOTE:** Make sure front of stand and front of saw are facing the same direction.
5. Line up the four holes in saw base, dust chute and stand.
6. Fasten saw to dust chute to stand using four bolts (10), washers (11) and nuts (8).
- NOTE:** Place washer on each bolt before inserting into saw base and through the support. Nut must be flush against the bracket (see Fig. A).
7. Tighten all four nuts.
- NOTE: DO NOT OVER TIGHTEN NUTS HOLDING SAW TO STAND. THIS MAY DAMAGE THE SAW BASE.**
8. Carefully set the saw in its upright position on a clean level surface.

Fig. A

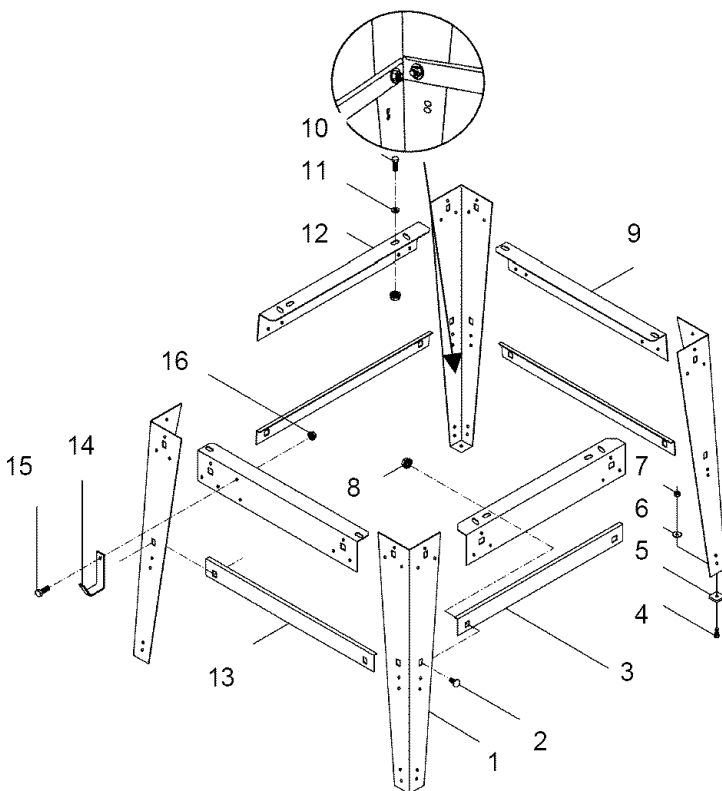
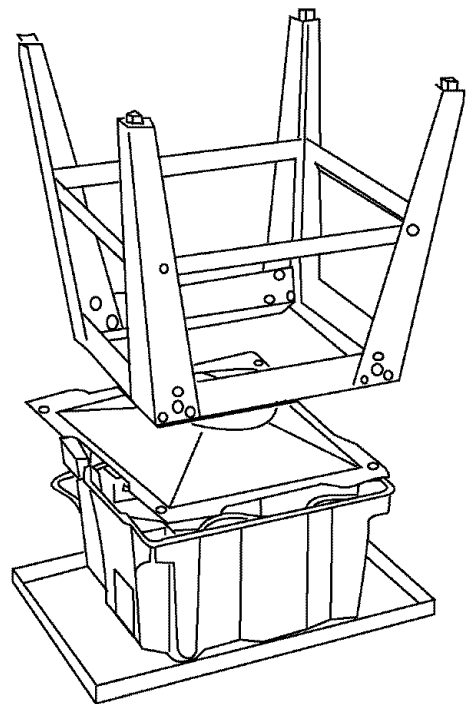

Fig. B



SAW MOUNTED TO WORK SURFACE (FIG. C)

1. If the leg set will not be used, the saw must be properly secured to a sturdy workbench using the four mounting holes at the base of the saw.
2. The surface of the table where the saw is to be mounted must have a hole large enough to facilitate sawdust fall-through and removal.
3. Square the saw on the mounting surface and mark the location of the four 3/8" mounting holes (1).
4. Drill 3/8" hole into the mounting surface.
5. Mark an 11" square (2) centered between the four mounting holes (1).
6. Cut out and remove the square.
7. This opening will allow sawdust to fall through the saw base.
8. Place the saw on the work surface, and align the mounting holes of the saw with those drilled through the surface.
9. Fasten the saw to the work surface.

▲ WARNING

Do not operate this machine on the floor. This is very dangerous and may cause serious injury.

Fig. C

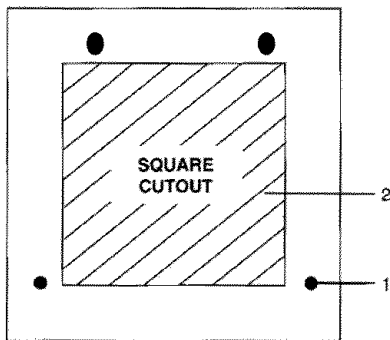

▲ WARNING

Failure to provide the sawdust fall-through hole for use of the saw when mounted to a work surface and not the stand will cause sawdust to build up in the motor area, which may result in fire or cause motor damage.

▲ WARNING

Always keep your work area clean, uncluttered and well lit.

1. If the dust bag is not used, do not work on floor surfaces that are slippery from sawdust or wax.
2. When using the dust bag some dust will not fall into the bag but come out through openings in the housing. Do not cover the motor cooling vents.

INSTALLING THE DUST BAG (FIG. D)

▲ WARNING

Do not use this saw to cut and/or sand metals. The hot chips or sparks may ignite sawdust or the bag material. Place the dust bag around the neck of the dust chute and tie the dust bag pulling the string tight and secure with the spring-loaded tie clip.

Fig. D

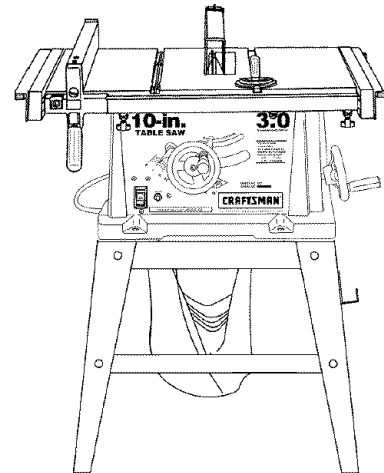

BLADE RAISING HANDWHEEL (FIG. E, F)

1. Attach the up ~ down handwheel (1) to the elevation rod (2) at the front of the saw.
Make sure the slots (3) in the hub of the handwheel engage with the pins (4).
2. Attach and tighten the dome nut (5 - Fig. F).

Fig. E

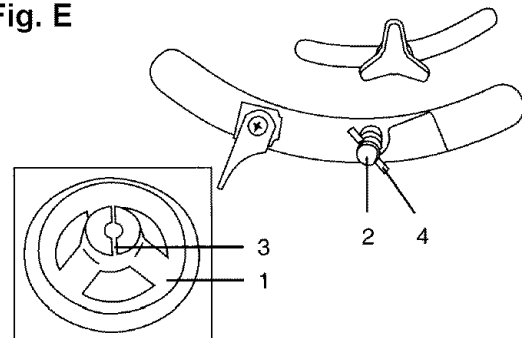

BLADE TILTING HANDWHEEL (FIG. F)

1. Attach the bevel 0° ~ 45° handwheel (6) to the blade tilting rod on the right side of the saw in the same manner as above.
2. Attach and tighten the handwheel dome nut (5).

Fig. F

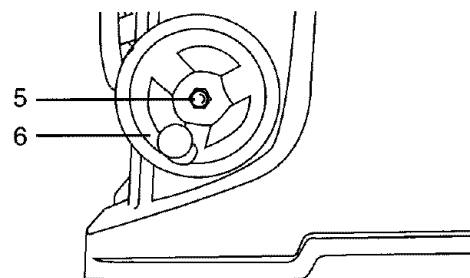

RIP FENCE (FIG. G)

1. Thread the fence handle (1) into the cam hole (2) until tight. Secure by tightening the nut (5) against the fence head.
2. Lift upward on the rip fence handle (1) so that the rear holding clamp (3) is fully extended.
3. Place the rip fence on the saw table engaging the rear holding clamp (3) to the table rear of the table first, then lower the front end onto the table (4).
4. Push down on the fence handle (1) to lock.

Fig. G

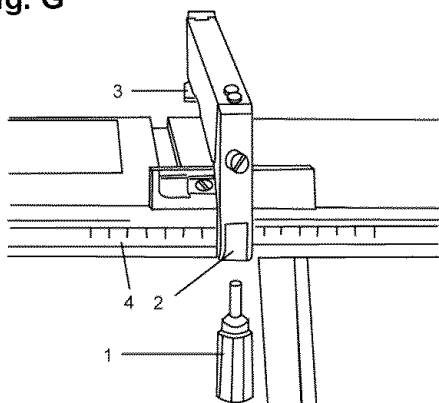

INSTALLING AND CHANGING THE BLADE (FIG. H, I, J)

⚠ WARNING

- To avoid injury from an accidental start, make sure the switch is in the OFF position and the plug is not connected to the power source outlet.
- To avoid serious injury, table insert must be level with the table. If the table insert is not level with the table, adjust the screw (3) until it is level with the table. To raise the insert, turn the screw counterclockwise, to lower the insert, turn the screw clockwise. Note: A rubber adjusting spacer is provided under rear of insert for this purpose.

1. Remove the table insert (1) by removing the two screws (2, 3). Be careful not to lose the rubber washer that is on the back screw (3) beneath the table insert. (Fig. H)

Fig. H

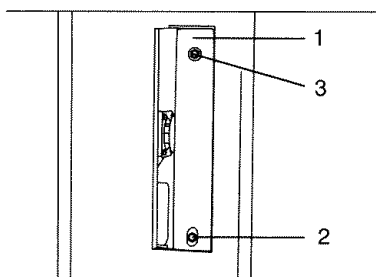

2. Raise the blade arbor (4) (Fig. I) to the maximum height by turning the blade raising handwheel counterclockwise.
3. Place the open-end wrench jaws on the flats of the saw arbor to keep the arbor from turning. (Fig. J) and place the box-end wrench (8) on the arbor nut (5), and turn counterclockwise.
4. Remove the arbor nut (5) and outer flange (6).
5. Install the saw blade onto the arbor with the blade teeth pointing toward the front of the saw.
6. Install the flange (6) against the blade and thread the arbor nut (5) as far as possible by hand. Ensure that the blade is flush against the inner side of the blade flange.

⚠ WARNING

To avoid possible injury and damage to the workpiece be sure to install the blade with the teeth pointing toward the front of table in the direction of the rotation arrow on the blade guard.

Fig. I

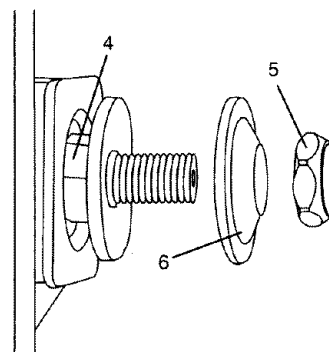

7. To tighten the arbor nut (5) place the open-end wrench jaws on the flats of the saw arbor to keep the arbor from turning. (Fig. J)
8. Place the box-end wrench (9) on the arbor nut (5), and turn clockwise (to the rear of the saw table).
9. Replace the blade insert in the table recess, insert the screws through the front and rear holes and tighten remembering the rubber washer under the rear of the insert.

Fig. J

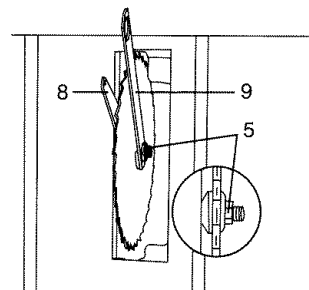

⚠ WARNING

To avoid injury from a thrown workpiece, blade parts, or blade contact, never operate saw without the proper insert in place. Use the original installed insert for all sawing operations except dado cuts. Use the dado head insert when using a dado.

BLADE GUARD ASSEMBLY & ALIGNMENT (FIG. K, L, M)

1. Set the blade to maximum height and the tilt to zero degrees on the bevel scale with the hand wheels. Lock the blade lock knob.
2. Place the spring washer (2), flat washer (3), external tooth lock washer (4) onto the blade guard mounting bolt (1). (Fig. K)

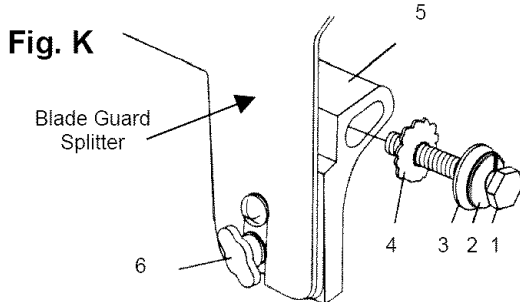

3. Place the oval washer (5) on the pivot rod (6). (Fig. L)
4. Install the blade guard splitter & bracket assembly (4) into the rear of the saw table. Thread the bolt (3) into the internally threaded pivot rod until snug.

NOTE: The blade guard & splitter is removed from the illustration for clarity.

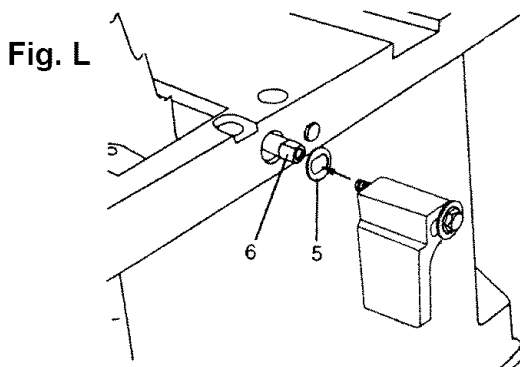

5. Lift blade guard arm (7) up and using a straight edge, align the blade guard splitter (8) with the saw blade (9). (Fig.M)
6. Shift the splitter assembly to right or left until parallel alignment to the blade is achieved.
7. When the splitter is properly aligned with the saw blade, tighten the bolt securely.

NOTE: The splitter must always be correctly aligned so that the cut workpiece will pass on either side without binding or twisting to the side.

⚠ WARNING

Improper splitter alignment can cause "kickback" and Serious injury.

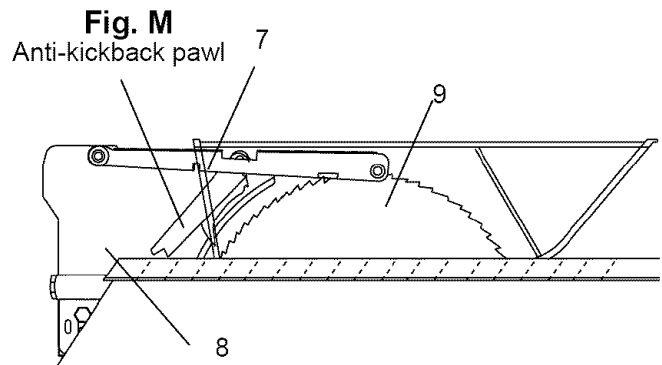

INSTALLING THE TABLE EXTENSION FENCE (FIG. N, N-1)

NOTE:

- A. For right ripping a 10" ~ 14" wide workpiece, the right extension fence has to be installed in the IN-RIP position (Fig. N). For left ripping a 11" ~ 16" wide workpiece, the left extension fence has to also be installed in the IN-RIP position. Raise the fence to a position that just clears the table surface and secure in place using lock handles (1) for IN-RIP position.
 - B. For right ripping a 14" ~ 24" wide workpiece, the right extension fence has to be installed in the OUT-RIP position (Fig. N-1). For left ripping a 16" ~ 24" wide workpiece, the left extension fence has to be installed in the OUT-RIP position.
1. Install the locking knobs (1) on the aluminum extension table.
 2. Place the table extension fence (2) on the aluminum extension table.
 3. Raise the fence to the desired location & height and tighten the lock knobs (1).

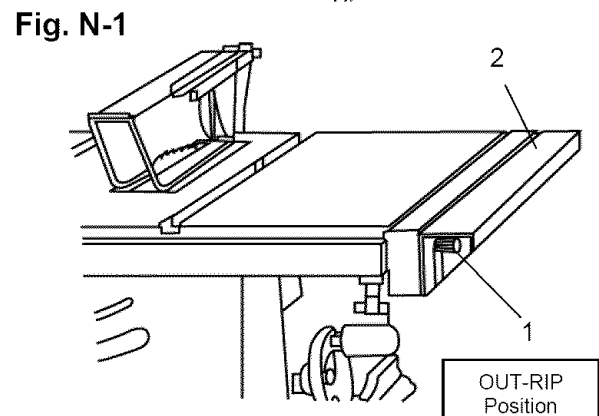
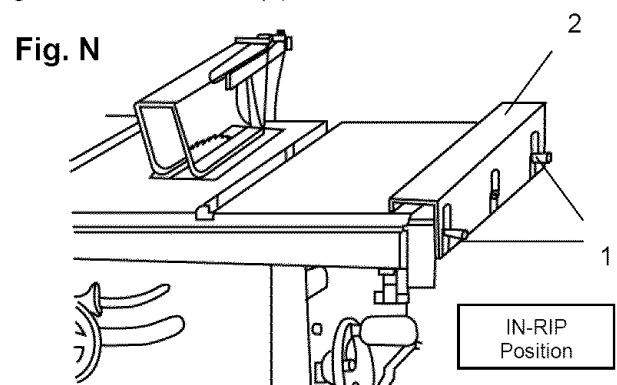

ADJUSTMENT INSTRUCTIONS

▲ WARNING

To avoid injury from an accidental start, make sure the switch is in the OFF position and the plug is not connected to the power source, before making any adjustments.

USING THE TABLE EXTENSION FENCE (FIG. N-2)

NOTE: The table extension may be used as side support when cutting large workpieces.

To adjust the table extension position

1. Loosen the two lock knobs (4) on the two extension tube brackets.
2. Slide the extension tubes in or out to the desired distance and tighten the two lock knobs (4).
3. Loosen lock knobs (5) and lower the table extension fence (6) level to the table and tighten the lock knobs making sure the table extensions are in the out-rip position.

Fig. N-2

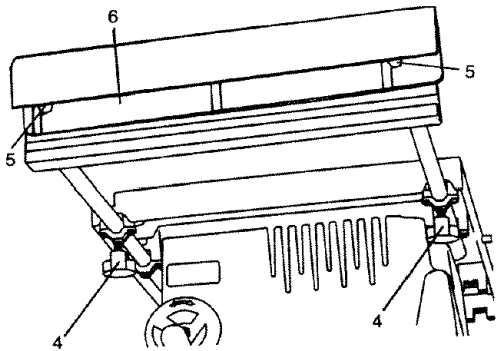

MITER GAUGE ADJUSTMENT (FIG. O)

1. Make sure that the miter gauge will slide freely through both table grooves.
2. Loosen the lock knob (1). Set the miter head (3) to 90°.
3. Adjust the pointer (2) to 90° on the miter gauge scale.

Note: This miter gauge is designed with positive detents every 15° for accuracy.

Fig. O

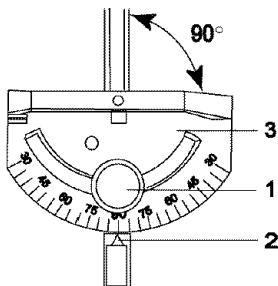

RIP FENCE ADJUSTMENT (FIG. P)

1. The fence (1) is moved by lifting up on the locking handle (2) and sliding the fence to the desired location. Pushing down on the handle locks the fence in position.
2. Position the fence on the table and along one edge of the miter gauge grooves.
3. Lock the fence handle. The fence should be parallel with the miter gauge groove.
4. If adjustment is needed to make the fence parallel to the groove, do the following:
 - Loosen the two screws (3) and lift up on the handle (2).
 - Hold the fence bracket (4) firmly against the front of the saw table. Move the far end of the fence until it is parallel with the miter gauge groove.
 - Tighten both screws and push the handle to lock.
5. If fence is loose when the handle is in the locked (downward) position, do the following:
 - Move the handle (2) upward and turn the adjusting screw (5) clockwise until the rear clamp is snug. Do not turn the adjusting screw more than 1/4 turn at a time.

Over-tightening the adjusting screw will cause the fence to come out of alignment.

▲ WARNING

Failure to properly align fence can cause “kickback” and serious injury.

NOTE: The rip fence and blade are aligned parallel to the miter gauge groove of the table.

Fig. P

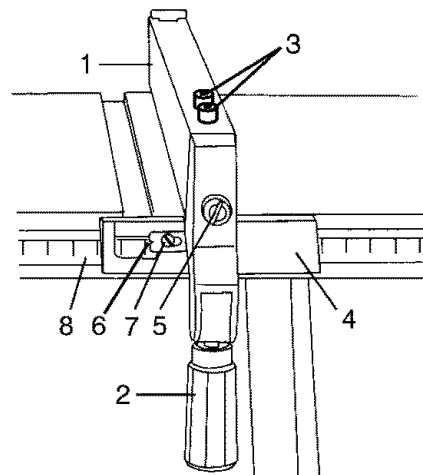

RIP FENCE INDICATOR ADJUSTMENT (FIG. P)

1. The rip fence indicator (6) points to the measurement scale (8). The scale shows the distance between the fence and the blade.
2. Measure the actual distance with a rule. If there is a difference between the measurement and the indicator, adjust the indicator (6).
3. Loosen the screw (7) and slide the indicator to the correct measurement on the scale. Tighten the screw and re-measure with the rule.

▲ WARNING

To avoid injury from an accidental start, make sure the switch is in the OFF position and the plug is not connected to the power source outlet.

ADJUSTING THE 90° AND 45° POSITIVE STOPS (FIG. Q, Q-1, R)

Your saw has positive stops that will quickly position the saw blade at 90° to the table. Make adjustments only if necessary.

90° Stop

1. Disconnect the saw from the power source.
2. Turn the blade elevation handwheel and raise the blade to the maximum elevation.
3. Loosen the blade bevel lock knob (2) and move the blade to the maximum vertical position, then tighten the lock knob (2).
4. Place a combination square on the table and against the blade (1) to determine if the blade is 90° to the table. (Fig. Q-1)
5. If the blade is not 90° to the table, loosen the two set screws (4), located on the collar (5) underneath the table saw, (Fig. R) with the hex key, and back off the collar..
6. Loosen the bevel lock knob. Turn the blade tilting handwheel to move the blade until it is 90° to the table.
7. Adjust the collar (5) so it contacts the bracket (3) when the blade is 90° to the table. Tighten the two set screws (4) (Fig.R).

Fig. Q

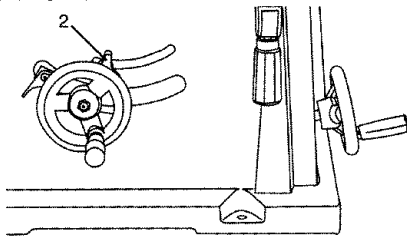
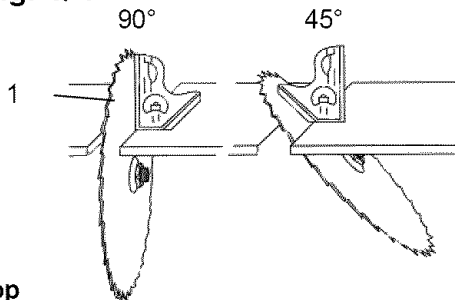

Fig. Q-1



45° Stop

1. With the blade in the upright 90° position, loosen the bevel lock knob and move the blade to the 45° position as far as it will go.
2. Place the combination square on the table as shown in Fig.Q-1 to check if the blade is 45° to the table.
3. If the blade is not 45° to the table, loosen the two set screws (4), located on the collar (5) underneath the table saw, (Fig. R) with the hex key, and back off the collar.
4. Tighten the bevel lock knob & secure the screw (4) until resistance is felt. Do not overtighten.

BLADE TILT POINTER

1. When the blade is positioned at 90°, adjust the blade tilt pointer to read 0° on the scale.
2. Loosen the mounting screw, position pointer over 0° and tighten the screw.

NOTE: Make a trial cut on scrap wood before making critical cuts. Measure for exactness.

Fig. R

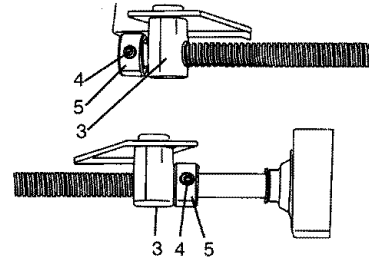

BLADE PARALLEL TO THE MITER GAUGE GROOVE (FIG. S, T)

This adjustment was made at the factory, but it should be rechecked and adjusted if necessary.

▲ WARNING

To prevent personal injury:

- Always disconnect plug from the power source when making any adjustments.
- This adjustment must be correct or kickback could result in a serious injury and accurate cuts can not be made.

1. Remove the safety switch key and unplug the saw.
2. Remove the blade guard for this procedure byt reinstall and realign after adjustment.
3. Raise the blade to the highest position and set at the 0° angle (90° straight up).
4. Select and mark, with a felt tip maker, a blade tooth having a "right set" and rotate the blade so the marked tooth is 1/2" above the table.
5. Place the combination square base (1) into the right side miter gauge groove (2). (Fig. S)
6. Adjust the rule so it touches the front marked tooth and lock ruler so it holds its position in the square assembly.
7. Rotate the blade bringing the marked tooth to the rear and about 1/2 inch above the blade.
8. Carefully slide the combination square to the rear until the ruler touches the marked tooth.
9. If the ruler touches the marked tooth at the front and rear position, no adjustment is needed at this time. If not or the base of the rule is no longer parallel with the edge of the miter gauge groove, perform adjustment procedure described in next section.

Fig. S

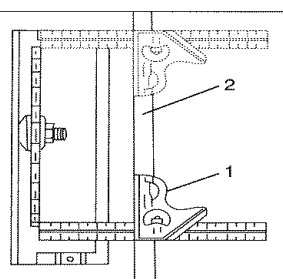

Additional blade adjustments (Fig. T)

TOOLS REQUIRED

- 10mm open end or 10mm combination wrench
- 4mm hex key
- Framing square
- Medium size flat blade screw driver

ADJUSTMENT PROCEDURE

1. Turn saw switch OFF and remove plug from the power source.
2. Remove blade guard and splitter assembly, miter gauge and rip fence.
3. Using the 10mm hex wrench, slightly loosen the two middle blade alignment rod strap bolts (1) and two rear blade alignment rod strap bolts (2) (see Fig. T).

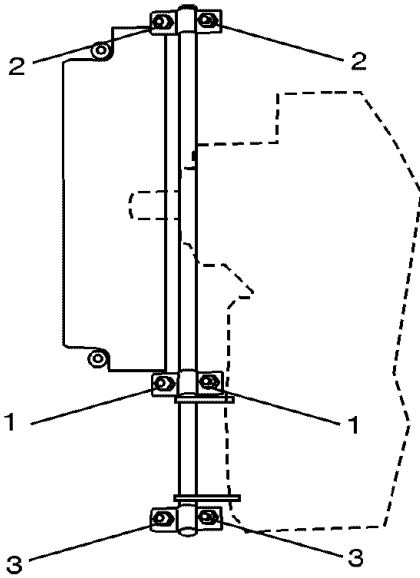

FRONT
Fig. T

4. While standing at the rear of the saw, use a medium size flat blade screwdriver and gently pry the rear of the blade alignment rod to the LEFT or RIGHT. Using the framing square, simultaneously measure the distance at the front and rear of the blade to an edge of a miter slot. When the distances are within 1/64" or closer, tighten both rear blade alignment rod strap bolts (2) while holding the rod firmly in place. NOTE: The blade alignment rod will only move slightly.
5. If alignment is not achieved by rear adjustment, loosen the two front blade alignment rod strap bolts (3).
6. While standing at the front of the saw, use a medium size flat blade screw driver and gently pry the front of

the blade alignment rod to the RIGHT or LEFT. Simultaneously measure the distance at the front and rear of the blade to an edge of a miter slot. When the distances are within 1/64" or closer, tighten both front blade alignment rod strap bolts (3) while holding the rod firmly in place. NOTE: The blade alignment rod will only move slightly to the right.

7. Tighten both middle blade alignment rod strap bolts (1). NOTE: Re-check to make sure all six bolts are properly tightened and that the distance from the front and rear of the blade to the miter gauge groove are within 1/64th of an inch from one another.
8. Re-install blade guard and splitter assembly and adjust the alignment with the blade as outlined earlier in the owner's manual.

OPERATION

BASIC SAW OPERATIONS

RAISE THE BLADE (FIG. U)

To raise or lower the blade, turn the blade elevation handwheel (1) to the desired blade height.

Fig. U

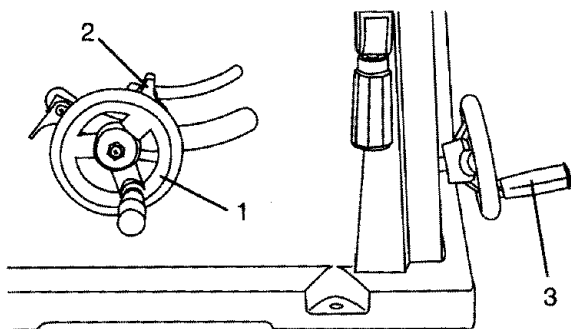

TILTING THE BLADE (FIG. U)

1. To tilt the saw blade for bevel cutting, loosen the lock knob (2) and turn the tilting handwheel (3) to the desired angle.
2. Tighten the bevel lock knob (2) to secure the angle.

ON/OFF SWITCH (FIG. V)

The ON / OFF switch has a removable safety key. With the key removed from the switch, unauthorized and hazardous use by children and others is minimized.

1. To turn the saw ON, insert key (1) into the slot in the switch (2). Move the switch upward to the ON position.
2. To turn the saw OFF, move the switch downward.
3. To lock the switch in the OFF position, grasp the end of the toggle switch (1) and pull out the safety switch key.
4. With the switch key removed, the switch will not operate.
5. If the switch key is removed while the saw is running, it can be turned OFF but cannot be restarted without inserting the switch key (1).

Fig. V

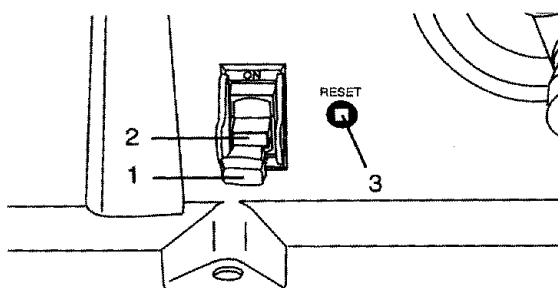

OVERLOAD PROTECTION (FIG. V)

This saw has a reset overload relay button (3) that will restart the motor after it shuts off due to overloading or low voltage. If the motor stops during operation, turn the ON / OFF switch to the OFF position. Wait for the motor to cool. Push in on the reset button (3) and turn the switch to the ON position.

⚠ WARNING

To avoid injury, the ON / OFF switch must be in the OFF position and the plug removed from the power source while the cool down takes place, to prevent accidental starting when the reset button is pushed. Overheating may be caused by misaligned parts or a dull blade. Inspect your saw for proper setup before using it again.

USING THE TABLE EXTENSION FENCE (FIG. W)

- A. **NOTE:** For right ripping a 10" ~ 14" wide workpiece, the right extension fence has to be installed in the IN-RIP position (Fig. N). For left ripping a 11" ~ 16" wide workpiece, the left extension fence has to also be installed in the IN-RIP position. Raise the fence to a position that just clears the table surface and secure in place using lock handles (1) for IN-RIP position.
- B. For right ripping a 14" ~ 24" wide workpiece, the right extension fence has to be installed in the OUT-RIP position (Fig. N-1). For left ripping a 16" ~ 24" wide workpiece, the left extension fence has to be installed in the OUT-RIP position.
1. Adjust the fence to the desired distance from the blade by reading the rip scale located on the front tube of the extension fence assembly.
 2. Raise the fence so the top is approximately 1/2" above the table of the saw and secure in position by tightening the two lock knobs (1).

NOTE: NEVER USE A RIP FENCE AND THE MITER GAUGE AT THE SAME TIME. KICKBACK CAN OCCUR.

Fig. N

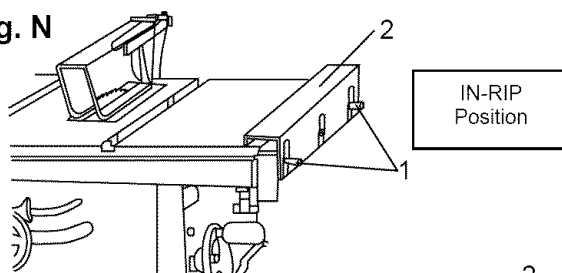
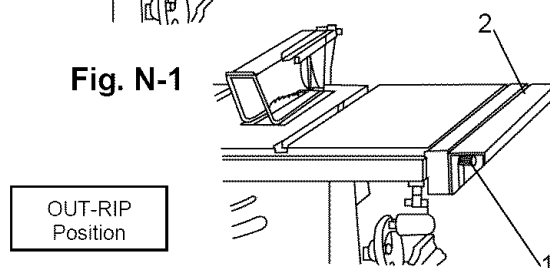

Fig. N-1



CUTTING OPERATIONS

There are two basic types of cuts: ripping and crosscutting. Ripping is cutting along the length and with the grain of the workpiece. Crosscutting is cutting either across the width or across the grain of the workpiece. Neither ripping nor crosscutting may be done safely freehand. Ripping requires the use of the rip fence, and crosscutting requires the miter gauge. Never use a rip fence and miter gauge at the same time.

⚠ WARNING

Before using the saw each and every time, check the following:

1. Blade is tight on the arbor.
2. Bevel angle lock knob is tight.
3. If ripping, fence lock handle is tight and fence is parallel to the blade.
4. Blade guard is in place and working properly.
5. Safety glasses are being worn.

The failure to adhere to these common safety rules, and those printed in the front of this manual, can greatly increase the likelihood of injury.

RIPPING (FIG. X, Y)

⚠ WARNING

To prevent serious injury:

- Never use the miter gauge when ripping.
- Never use more than one rip fence during a single cut.
- Do not allow familiarity or frequent use of your table saw to cause careless mistakes. Remember that even a careless fraction of a second is enough to cause a severe injury.
- Keep both hands away from the blade and path of the blade.
- The workpiece must have a straight edge against the fence and must not be warped, twisted, or bowed.
- DANGER – Never attempt to pull the workpiece backwards during a cutting operation. This will cause kickback and serious injury to the user can occur.

1. Remove the miter gauge. Secure the rip fence to the table or if using the extension fence, set the position and remove all other rip fences from the table..
2. Raise the blade so it is about 1/8" higher than the top of the workpiece.
3. Place the workpiece flat on the table and against the fence. Keep the workpiece about 1" away from the blade.
4. Turn the saw ON and wait for the blade to come up to speed.
5. Slowly feed the workpiece into the blade by pushing forward only on the workpiece section (1) that will pass between the blade and the fence. (Fig. X)

⚠ WARNING

AVOID KICKBACK by pushing forward that section of the workpiece that will pass between the blade and the fence. Use a push stick at all times.

Fig. X

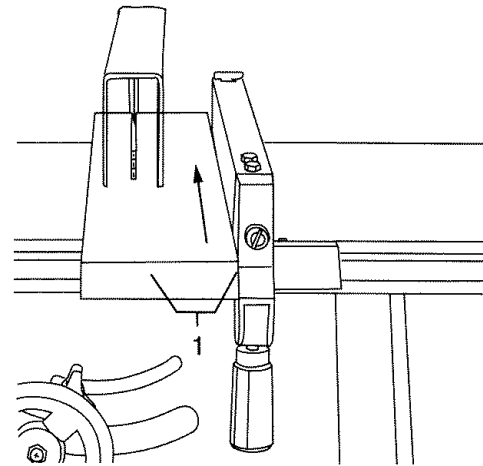

6. Keep your thumbs off the blade top. When both of your thumbs touch the front edge of the table (2), finish the cut with a push stick. You can make a push stick using the pattern on page 30.
7. The push stick (3) should always be used for any ripping operation.
8. Continue pushing the workpiece with the push stick (3) until it passes the blade guard and clears the rear of the table.
9. DANGER - Never attempt to pull the workpiece backwards during a cutting operation. This will cause kickback and serious injury to the user can occur. When the blade completely stops raise the anti-kickback pawls on each side of the splitter and slide the workpiece out.

Fig. Y

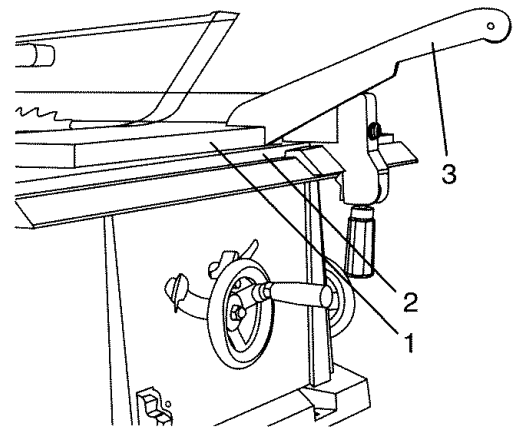

BEVEL RIPPING

This cut is the same as ripped except the blade bevel angle is set to an angle other than "0".

⚠ WARNING

Cut only with the workpiece and the fence on the right side of the blade.

⚠ WARNING

Never attempt to pull the workpiece backwards during a cutting operation. This will cause kickback and serious injury to the user can occur.

RIPPING SMALL PIECES

⚠ WARNING

Avoid injury from the blade contact. Never make through-saw cuts narrower than 3/4" wide.

1. It is unsafe to rip small pieces. Instead, rip a larger piece to obtain the size of the desired piece.
2. When a small width is to be ripped, your hand cannot be safely put between the blade and the rip fence, therefore, use one or more push sticks to pass the workpiece completely through and past the blade.

CROSSCUTTING 90° MITER ANGLE (FIG. Z)

⚠ WARNING

To prevent serious injury:

- Do not allow familiarity or frequent use of your table saw to cause careless mistakes. Remember that even a careless fraction of a second is enough to cause a severe injury.
- Keep both hands away from the blade and the path of the blade.
- DANGER - Never attempt to pull the workpiece backwards during a cutting operation. This will cause kickback and serious injury to the user can occur.

1. Remove the rip fence lower all table extension fences flush to the table and place the miter gauge a miter gauge groove on the table.
2. Adjust the blade height so it is 1/8" higher than the top of the workpiece.
3. Hold the workpiece firmly against the miter gauge with the blade path in line with the desired cut location. Move the workpiece to one inch distance from the blade.
4. Start the saw and wait for the blade (1) to come up to full speed. Never stand directly inline of the saw blade path, always stand to the side of the blade that you are cutting on.
5. Keep the workpiece (2) against the face of the miter gauge (3) and flat against the table. Then slowly push the workpiece through the blade.
6. Do not try to pull the workpiece back with the blade turning. Turn the switch OFF, and carefully slide the workpiece out when the blade is completely stopped.

⚠ WARNING

Always position the larger surface of the workpiece on the table when crosscutting and/or bevel crosscutting to avoid instability.

Fig. Z

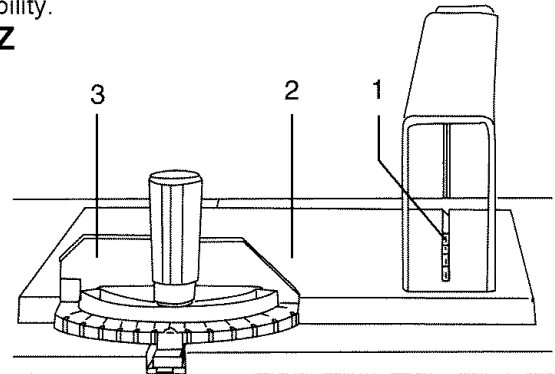

BEVEL CROSSCUTTING (FIG. AA)

0°~45° BLADE BEVEL & 90° MITER ANGLE

This cutting operation is the same as crosscutting except the blade is at bevel angle other than 0°.

1. Adjust the blade (1) to the desired angle, and tighten the blade bevel lock knob.
2. Always work to the left side of the blade. The miter gauge (3) must be in the left side groove (2). It cannot be used in the right side groove unless the miter angle is very sharp, as it will interfere with the blade guard.

Fig. AA

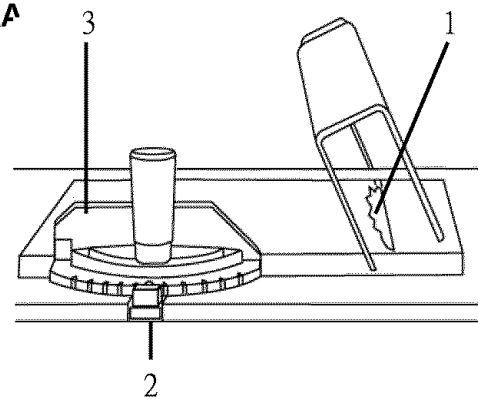

COMPOUND MITER CROSSCUTTING (FIG. BB)

0°~45° BLADE BEVEL & 0°~45° MITER ANGLE

This sawing operation is combining a miter angle with a bevel angle.

WARNING - Always work to the left side of the blade during this type of cut. The miter gauge (3) must be in the left side miter gauge groove. It cannot be used in the right side groove unless the miter angle is very sharp, as it will interfere with the blade guard.

1. Set the miter gauge (3) to the desired angle. Use only the left side groove (2).
2. Set the blade (1) bevel to the desired angle.
3. Carefully push the miter gauge to begin the cutting operation.

Fig. BB

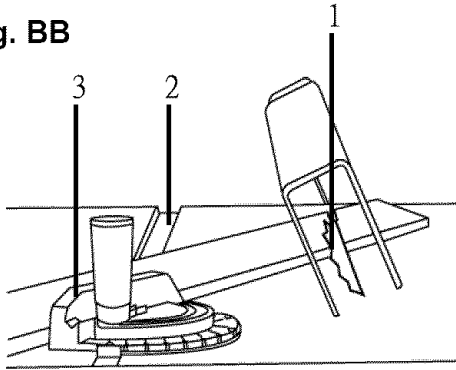

MITERING (FIG. CC) 0°~45° MITER ANGLE

This sawing operation is the same as crosscutting except the miter gauge is locked at an angle other than 90°.

WARNING - Always work to the left side of the blade during this type of cut. The miter gauge (3) must be in the left side miter gauge groove. It cannot be used in the right side groove unless the miter angle is very sharp, as it will interfere with the blade guard.

1. Hold the workpiece (2) firmly against the miter gauge (3).
2. Feed the workpiece slowly into the blade (1) to prevent the workpiece from moving.

Fig. CC

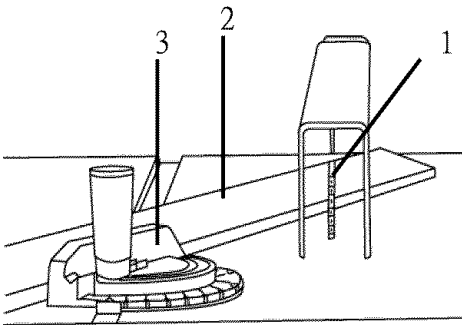

USING WOOD FACING ON THE RIP FENCE (FIG. DD)

When performing some special cutting operations, You can add a wood facing (1) to either side of the rip fence (2).

NOTE: Before using wood facing on the rip fence, make sure the auxiliary fences are lowered flush to the table top.

1. Use a smooth straight 3/4" thick wood board (1) that is as long as the rip fence.
2. Attach the wood facing to the fence with wood screws (3) through the hole in the fence. A wood fence should be used when ripping material such as thin paneling to prevent the material from catching between the bottom of the fence and the table.

Fig. DD

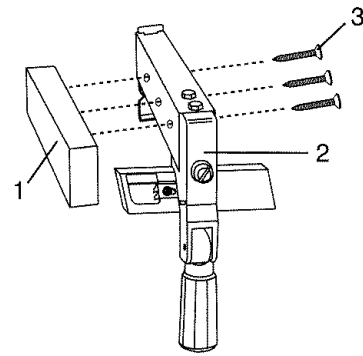

DADO CUTS (FIG. EE)

1. The dado table insert is included with this saw. Remove saw blade and blade guard for dado cuts only. Reinstall and realign blade guard for all through sawing operations. Install a dado not exceeding 6" diameter and 1/2" width and the dado table insert.
2. Instruction for operating the dado is packed with the separately purchased dado set.
3. The arbor (1) on this saw restricts the maximum width of the cut to 1/2".
4. It is not necessary to install the outside flange (2) before threading on the arbor nut (3) for maximum 1/2" dado cuts. Make sure that the arbor nut (3) is tight, and that at least one thread of the arbor sticks out past the nut.
5. Use only the 6" diameter dado set and keep the width 1/2" or less. It will be necessary to remove the blade guard and splitter when using a dado blade only. Always use caution when operating a dado blade.
6. Use only the correct number of round outside blades and inside chippers as shown in the dado set's instruction manual. Blades/chippers must not exceed 1/2" total in width.
7. Check saw to ensure that the dado will not strike the housing, insert, or motor when in operation.

▲ WARNING

For your own safety, always replace the blade, blade guard assembly, and blade insert when you are finished with the dado operation. You must also realign the blade guard assembly.

Fig. EE

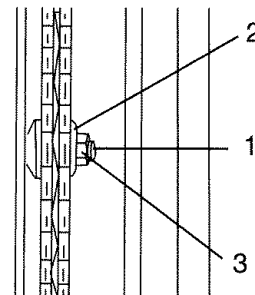

MAINTENANCE

MAINTAINING YOUR TABLE SAW

GENERAL MAINTENANCE

⚠ WARNING

For your own safety, turn the switch OFF and remove the switch key. Remove the plug from the power source outlet before maintaining or lubricating your saw.

1. Clean out all sawdust that has accumulated inside the saw cabinet and the motor.
2. Polish the saw table with an automotive wax to keep it clean and to make it easier to slide the workpiece.
3. Clean cutting blades with pitch and gum remover.
4. A worn, cut, or damaged power cord should be replaced immediately.

⚠ WARNING

All electrical or mechanical repairs should be attempted only by a trained repair technician. Contact the nearest Sears Service Center for service. Use only identical replacement parts. Any other parts may create a hazard.

5. Use liquid dish washing detergent and water to clean all plastic parts.

NOTE: Certain cleaning chemicals can damage plastic parts.

6. Avoid use of the following cleaning chemicals or solvents; ammonia and household detergents containing ammonia.

BLADE RAISING AND TILTING MECHANISM

After each five full hours of operation, the blade raising mechanism and tilting mechanism should be checked for looseness, binding, or other abnormalities. With the saw disconnected from the power source, turn the saw upside down and alternately pull upward and downward on the motor unit. Observe any movement of the motor mounting mechanism. Looseness or play in the blade raising screw (1) (Fig. FF) should be adjusted as follows:

1. Using a 14mm wrench, loosen the check-nut (2).
2. Adjust nut (3) until it is finger-tight against the bracket (4), then back off the nut (3) 1/6 turn.
3. Tighten nut (2) with the wrench, while holding nut (3) in place. Maximum allowable play in and out of the screw rod (1) is 1/8".

Fig. FF

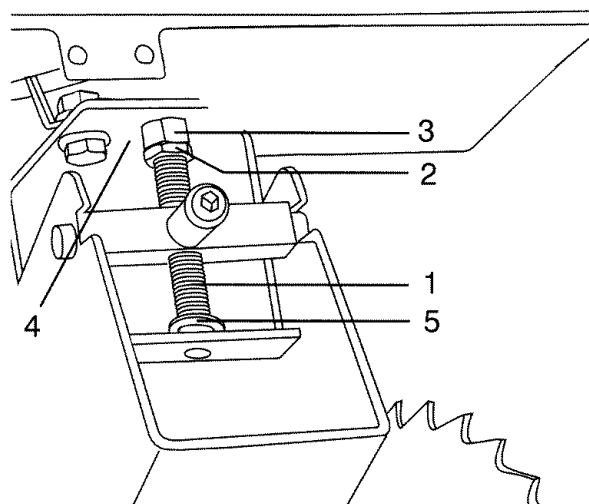

You can place a small amount of dry lubricant on bevel angle adjustment rod also. This rod (1) must be kept clean and free of sawdust, gum, pitch, and other contaminants for smooth operation.

If excessive looseness is observed in any parts of the blade raising mechanism or tilting mechanism, take the complete unit to a Sears Service Center.

LUBRICATION

All motor bearings are permanently lubricated at the factory and require no additional lubrication.

On all mechanical parts of your table saw where a pivot or threaded rod are present, lubricate using graphite or silicone. These dry lubricants will not hold sawdust as would oil or grease.

TROUBLESHOOTING GUIDE

▲ WARNING

To avoid injury from an accidental start, turn the switch OFF and always remove the plug from the power source before making any adjustments.

- Consult your local Sears Service Center if for any reason the motor will not run.

SYMPTOM	POSSIBLE CAUSES	CORRECTIVE ACTION
Saw will not start	<ol style="list-style-type: none"> 1. Saw not plugged in 2. Fuse blown or circuit breaker tripped 3. Cord damaged 	<ol style="list-style-type: none"> 1. Plug in saw 2. Replace fuse or reset circuit breaker 3. Have cord replaced by a Sears Service Center
Does not make accurate 45° and 90° rip cuts	<ol style="list-style-type: none"> 1. Positive stop not adjusted correctly 2. Tilt angle pointer not set accurately 	<ol style="list-style-type: none"> 1. Check blade with square and adjust positive stop 2. Check blade with square and adjust to zero
Material pinched blade when ripping	<ol style="list-style-type: none"> 1. Rip fence not aligned with blade 2. Warped wood, edge against fence is not straight 	<ol style="list-style-type: none"> 1. Check and adjust rip fence 2. Select another piece of wood
Material binds on splitter	<ol style="list-style-type: none"> 1. Splitter not aligned correctly with blade 	<ol style="list-style-type: none"> 1. Check and align splitter with blade
Saw makes unsatisfactory cuts	<ol style="list-style-type: none"> 1. Dull blade 2. Blade mounted backwards 3. Gum or pitch on blade 4. Incorrect blade for work being done 5. Gum or pitch on blade causing erratic feed 	<ol style="list-style-type: none"> 1. Replace blade 2. Blade teeth must face forward 3. Remove blade and clean with turpentine and coarse steel wool 4. Change the blade 5. Clean table with turpentine and steel wool
Material kicked back from blade	<ol style="list-style-type: none"> 1. Rip fence out of adjustment 2. Splitter not aligned with blade 3. Feeding stock without rip fence 4. Splitter not in place 5. Dull blade 6. The operator letting go of material before it is past saw blade 	<ol style="list-style-type: none"> 1. Align rip fence with miter gauge slot 2. Align splitter with blade 3. Install and use rip fence 4. Install and use splitter (with guard) 5. Replace blade 6. Push material all the way past saw blade and off the table before releasing work
Blade does not raise or tilt freely	<ol style="list-style-type: none"> 1. Sawdust and dirt in raising and tilting mechanisms 	<ol style="list-style-type: none"> 1. Brush or blow out loose dust and dirt
Blade does not come up to speed	<ol style="list-style-type: none"> 1. Extension cord too light or too long 2. Low house voltage 	<ol style="list-style-type: none"> 1. Replace with adequate size gauge cord 2. Contact your electric company
Machine vibrates excessively	<ol style="list-style-type: none"> 1. Saw not mounted securely to workbench 2. Bench on uneven floor 3. Damaged saw blade 	<ol style="list-style-type: none"> 1. Tighten all mounting hardware 2. Reposition on flat level surface Fasten to floor if necessary 3. Replace blade
Does not make accurate 45° and 90° cross cuts	<ol style="list-style-type: none"> 1. Miter gauge out of adjustment 	<ol style="list-style-type: none"> 1. Replace miter gauge or check blade alignment

PARTS LIST

10" TABLE SAW PARTS LIST

MODEL: 137.218041

▲ WARNING

When servicing use only CRAFTSMAN replacement parts. Use of any other parts may create a HAZARD or cause product damage.

▲ WARNING

Any attempt to repair or replace electrical parts on this Table Saw may create a HAZARD unless repair is done by a qualified service technician. Repair service is available at your nearest Sears Service Center.

Always order by I.D.NO.

Schematic A

I.D. No.	Description	Size	Qty
2009	TABLE		1
0806	KNOB		4
0B3B	SCALE		1
0B3H	INSERT		1
0B57	RIP FENCE ASS'Y		1
0B6S	CLAMP HANDLE	#23 M8*1.25-26	1
0B84	WASHER	D=φ 18	1
0B8A	WARNING STICK LABEL	PVC	1
0BCD	GUIDE HOLDER	#06	3
0BCT	SCALE		1
0H8H	CLAMP BOLT	#06	4
0J76	FLAT WASHER	1/4*3/4-1/16	1
0J95	SPRING WASHER	φ 6	1
0JAA	WASHER	φ 8	1
0JYN	HEX. SOC. COUNTERSUNK HD. SCREW	M6*1.0-25	6
0K3R	CR.RE. PAN HD. SCREW & WASHER	M5X0.8-12	2
0K5P	CR. RE. COUNT HD. SCREW	M6*1.0-50	3
0K5S	CR. RE. COUNT HD. SCREW	M6*1.0-55	1
0KCY	CR.RE. PAN HD PLAIN WASHER TAPPING SCREW	M5*0.8-12	4
0KDR	CR. RE. PAN HD. SCREW	M5*0.8-10	2
0KDS	CR. RE. PAN HD. SCREW	M5*0.8-40	4
0KDU	CR. RE. PAN HD. SCREW	M6*1.0-12	2
0KMS	HEX. NUT	M6*1.0 T=5	1
0KMY	HEX. NUT	M8*1.25 · T=6.5	1
0KSW	STRAIN RELIEF	φ 6.1	1
202N	BLADE GUARD ASS'Y		1
20L1	SLOTTED PAN HD.SCREW	M6*1.0-25	2
20LW	CR.RE. PAN HD. SCREW & WASHER	M5*0.8-16	6
20WQ	HEX. HD. BOLT	M6*1.0-50	1
22KU	WARNING LABEL		1
25MG	MITER GAUGE ASS'Y	#23	1
267K	SLIDING BASE	#06	2
27X4	EXTENTION WING(LEFT)		1
27X5	EXTENTION WING(RIGHT)		1
27X6	ASSIST-FENCE(LEFT)		1
27X7	ASSIST-FENCE(RIGHT)		1
27X8	UPER TUBE		1
27X9	UPER TUBE		1
27XA	UPER TUBE		1
27XB	UPER TUBE		1
27XL	END CAP	#06	4
28FE	CAUTION LABEL		1
28Q1	WARNING LABEL		1
28Q2	WARNING LABEL		1
28Q3	SCALE		1
29PD	WARNING LABEL		1

10" TABLE SAW PARTS LIST
Schematic B

MODEL: 137.218041

I.D. No.	Description	Size	Qty	I.D. No.	Description	Size	Qty
09JK	WRENCH HEX.	#06	1	0JEY	E-RING	E-9	1
0AV9	BODY SHELL	#53	1	0JXL	HEX. SOC. SET SCREW	M10*1.5-12	1
0B22	HEIGHT REGULATING BOLT		1	0K0Z	HEX. HD. SCREW AND WASHER	M8*1.25-16	4
0B23	SADDLE		1	0K16	HEX. HD. SCREW AND WASHER	M8*1.25-16	1
0B24	SPRING		1	0K25	HEX.SOCKET HD.CAP SCREWS	M5*0.8-20	1
0B25	POINTER BRACKET		1	0K3G	CR.RE. PAN HD. SCREW & WASHER	M5*0.8-12	1
0B2A	NEEDLE POINTER	#19	1	0K7K	CR. RE. ROUND WASHER HD. SCREW	M6*1.0-12	2
0B2C	SWITCH BOX	#06	1	0K8C	CR. RE.COUNT HD. TAPPING SCREW	M4*18-10	4
0B3K	INSERT		1	0K91	CR. RE. TRUSS HD. TAPPING SCREW	M4*16-12	4
0B3R	WRENCH		1	0KA4	CR.RE. PAN HD. TAPPING SCREW	M4*16-16	2
0B3Y	RETAINING CLIP		1	0KCX	CR. RE.COUNT HD. TAPPING SCREW	M5*0.8-10	2
0B48	WARNING LABEL		1	0KDU	CR. RE. PAN HD. SCREW	M6*1.0-12	2
0B97	MOTOR BRACKET		1	0KF6	CR. RE. PAN HD. SCREW	M4*0.7-8	1
0B99	SPACER		1	0KF7	CR. RE. PAN HD. SCREW	M4*0.7-12	2
0B9C	PLUNGER HOUSING		1	0KJ0	CAP HD. SQ.NECK BOLT	M6*1.0-16	2
0B9H	ANGLE ROD		1	0KJ4	CAP HD. SQ.NECK BOLT	M6*1.0-35	1
0B9M	STRAP		6	0KJ5	CAP HD. SQ.NECK BOLT	M6X1.0-80	1
0B9S	BRACKET		1	0KMR	HEX. NUT	M5*0.8 T=4	1
0B9W	BRACKET		1	0KMS	HEX. NUT	M6*1.0 T=5	1
0BA4	SPACER		1	0KMV	HEX. NUT	M10*1.5 T=8	1
0BAC	SET NUT		1	0KMW	HEX. NUT	M10*1.5 T=4	1
0BAE	ARBOR COLLAR		1	0KMY	HEX. NUT	M8*1.25 · T=6.5	1
0BAT	NUT		1	0KQJ	CROWN NUT	M8*1.25 T=12.5	2
0BAU	SUPPORTING PLATE		1	0KRQ	SERRATED TOOTHED HEXAGON FLANGE NUT	M6*1.0 T=6	6
0BAY	SCREW BAR		1	0KRX	HEXAGON NUT AND FLAT WASHER	M6*1.0	3
0BB3	CAUTION LABEL		1	0KRX	HEXAGON NUT AND FLAT WASHER	M6*1.0	4
0BPA	LOCK KNOB	#23	1	0KTA	STRAIN RELIEF		2
0G1U	DUST SHIELD		4	0L6G	POWER CABLE ASS'Y		1
0J3P	WRENCH HEX.		1	0LMG	LOCKING CABLE TIE		1
0J3U	WRENCH HEX.		1	0LSL	CIRCUIT BREAKER SWITCH		1
0J4F	FLAT WASHER	φ 8X16-2.5	1	0LVW	ROCKER SWITCH		1
0J4H	FLAT WASHER	φ 10*30-0.2	2	0QEF	MOTOR		1
0J70	FLAT WASHER	1/4*3/4-7/64	2	0QQ0	CLAMP-CORD		1
0J76	FLAT WASHER	1/4*3/4-1/16	4	0SRX	STIFFENER ASS'Y		1
0J76	FLAT WASHER	1/4*3/4-1/16	1	0STF	PARRLE RING ASS'Y		2
0J8D	FLAT WASHER	3/8*3/4-5/64	2	0STQ	HAND WHEEL ASS'Y	#06	1
0J9H	SPRING WASHER	φ 1/4"	6	0STR	HAND WHEEL ASS'Y	#06	1
0JAE	EXTERNAL TOOTH LOCK WASHER	φ 4	2	20Q9	BAG-DUST	#06	1
0JAE	EXTERNAL TOOTH LOCK WASHER	φ 4	1	212M	LEAD WIRE ASS'Y		1
0JC9	SPRING PIN	3-18	1	21CH	CR.RE. PAN HD. SCREW & WASHER	M5*0.8-10	1
0JCA	SPRING PIN	3-24	1	23PP	BLADE		1
0JCA	SPRING PIN	3-24	1	26HR	DUST COLLECTOR	#06	1
0JCR	SPRING PIN	8-90	1	27QV	PARTS BOX CARTON		1
0JE7	C-RING	A-9	1	29EB	LABEL		1
0JED	C-RING	A-16	1				

Schematic B

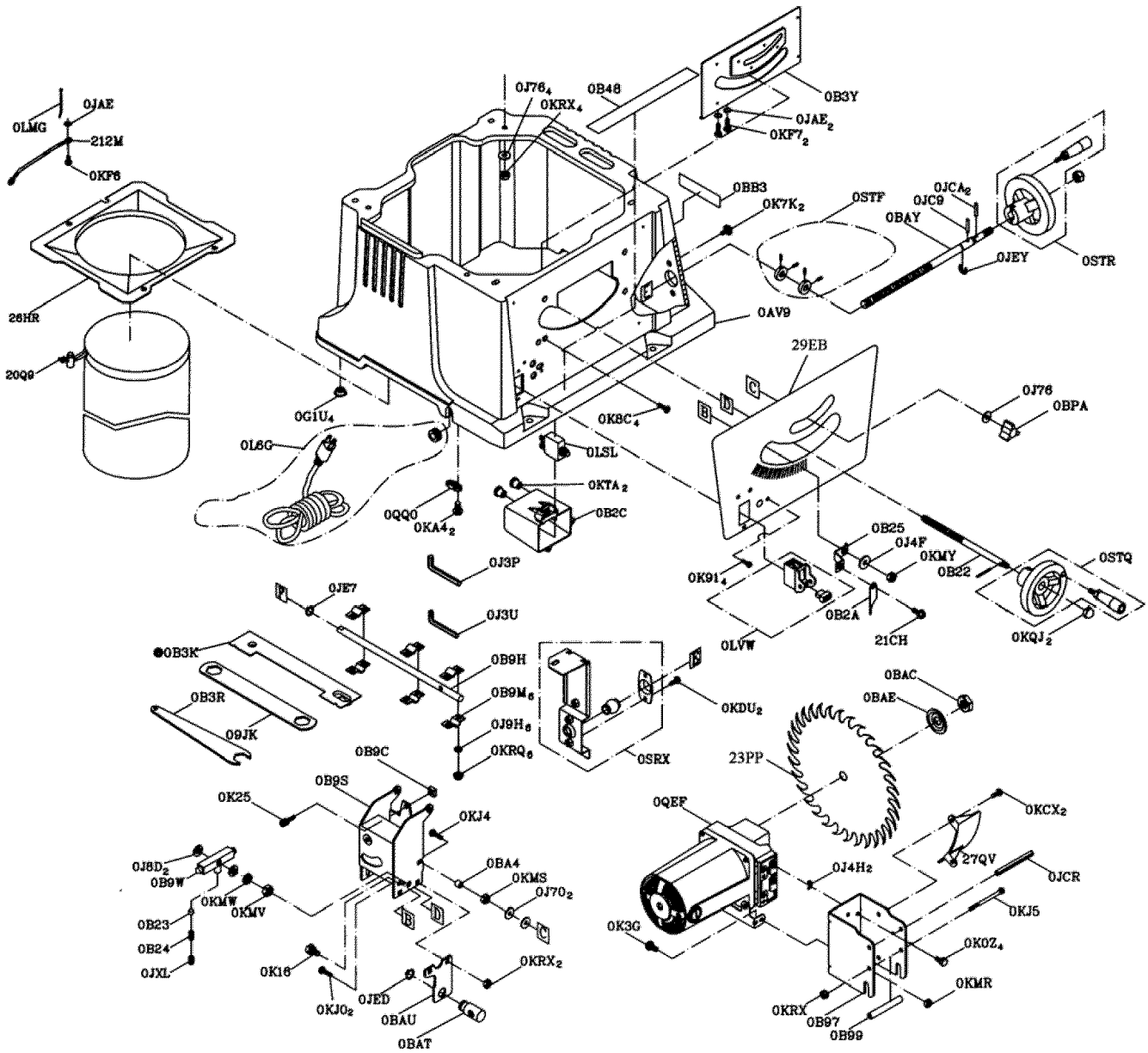

10" TABLE SAW
Part list for MOTOR

MODEL: 137.218041

I.D. No.	Description	Size	Qty
1502	FIELD ASS'Y		1
0HX9	NEEDLE BEARING	HK-1010	1
0JAL	EXT.TOOTH LOCK WASHER	φ4	4
0JX3	HEX. SOC. SET SCREW	M5x0.8-8	2
0K3A	CR.RE. PAN HD. SCREW & WASHER	M5x0.8-30	4
0K5V	CR.-RE. COUND.HD.SCREW	M4x0.7-8	4
0KCP	CR.RE. PAN HEAD TAPPING & WASHER SCREW	M5x12-60	2
0KTH	STRAIN RELIEF		1
0QDZ	BEARING RETAINER		1
0QE9	MOTOR NAMEPLATE		1
0QEA	BRACKET		1
0QEC	ARBOR SHAFT ASS'Y		1
0QED	SUPPORT PLATE		1
0QM2	BRUSH HOLDER ASS'Y		2
0QQT	BRUSH ASS'Y		2
0QR0	BRUSH COVER		2
0R1Q	MOTOR HOUSING	#6	1
0R1S	BEARING BUSHING		1
0R1Y	ARMATURE ASS'Y		1
0R20	BAFFLE	#6	1

10" TABLE SAW**MODEL: 137.218041****Part list for STAND**

I.D.No.	Description	Size	Qty
09D6	SPACER		4
0BBN	HOOK		3
0EA8	BRACKET		4
0EAH	UPPER SUPPORT	L=450	2
0EAU	UPPER SUPPORT	L=410	2
0EB2	BOTTOM SUPPORT BRACKET	L=526	2
0EBB	BOTTOM SUPPORT BRACKET	L=472	2
0J4F	FLAT WASHER	φ 8X16-2.5	4
0J4J	FLAT WASHER	φ 10X20-2	4
0JPC	HEX. HD. BOLT	M6*1.0-12	3
0JPP	HEX. HD. BOLT	M8*1.25-30	4
0JPX	HEX. HD. BOLT	M10*1.5-20	4
0KJ7	CAP HD. SQ.NECK BOLT	M8*1.25-16	16
0KMU	HEX. NUT	M10*1.5 T=8	4
0KRQ	SERRATED TOOTHED HEXAGON FLANGE NUT	M6*1.0 T=6	3
0KRR	SERRATED TOOTHED HEXAGON FLANGE NUT	M8*1.25 T=7.5	20
0Z1G	CAP HD. SQ.NECK BOLT	M8*1.25-12	16

STAND

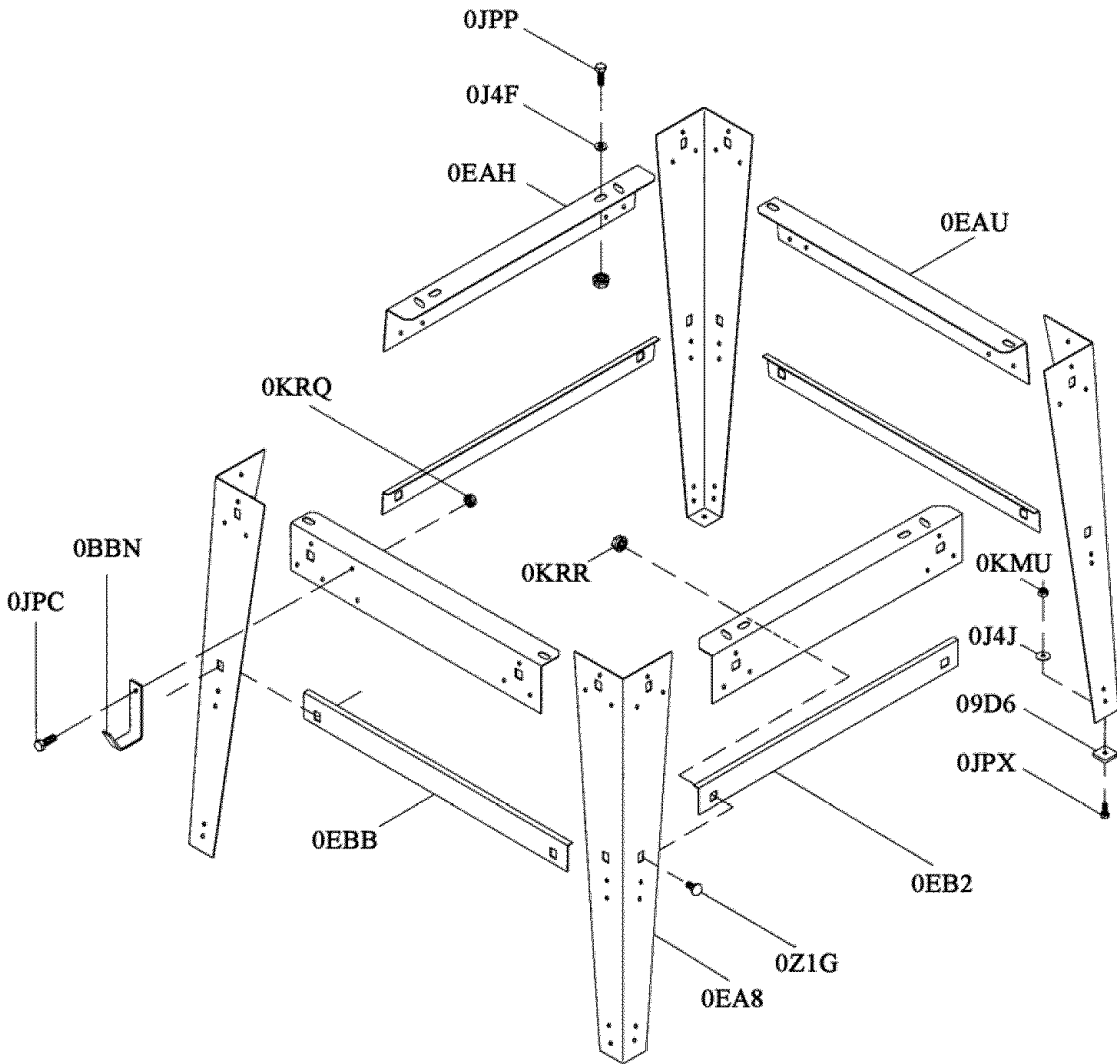

PUSH STICK CONSTRUCTION

- This is a full-size drawing (actual size)
- Use good quality plywood or solid wood
- Use $\frac{1}{2}$ " or $\frac{3}{4}$ " material
- Push stick MUST be thinner than the width of material being cut

Drill Hole For Hanging

Notch To Prevent Hand From Slipping

Cut Here To Push $\frac{1}{2}$ " Wood

Cut Here To Push $\frac{3}{4}$ " Wood

Get it fixed, at your home or ours!

Your Home

For repair – **in your home** – of **all** major brand appliances, lawn and garden equipment, or heating and cooling systems, **no matter who made it, no matter who sold it!**

For the replacement parts, accessories and Operator's Manuals that you need to do-it-yourself.

For Sears professional installation of home appliances and items like garage door openers and water heaters.

1-800-4-MY-HOME® (1-800-469-4663)

Call anytime, day or night (U.S.A. and Canada)

www.sears.com www.sears.ca

Our Home

For repair of carry-in items like vacuums, lawn equipment, and electronics, call or go on-line for the location of your nearest **Sears Parts & Repair Center.**

1-800-488-1222

Call anytime, day or night (U.S.A. only)

www.sears.com

To purchase a protection agreement on a product serviced by Sears:

1-800-827-6655 (U.S.A.)

1-800-361-6665 (Canada)

Para pedir servicio de reparación a domicilio, y para ordenar piezas:

1-888-SU-HOGARSM
(1-888-784-6427)

Au Canada pour service en français:

1-800-LE-FOYER^{MC}
(1-800-533-6937)
www.sears.ca

SEARS

© Registered Trademark / TM Trademark / SM Service Mark of Sears, Roebuck and Co.

© Marca Registrada / TM Marca de Fábrica / SM Marca de Servicio de Sears, Roebuck and Co.

^{MC} Marque de commerce / ^{MD} Marque déposée de Sears, Roebuck and Co.

© Sears, Roebuck and Co.