

Installation Instructions For Heavy Duty (FAS Models) and Median (FAM Models) Air Conditioners

Please read ALL instructions before installing. Two people are recommended to install this product. If a new electrical outlet is required, have the outlet installed by a qualified electrician *before* installing unit. See #5 in Preliminary Instructions following.

Preliminary Instructions

Do the following before starting to install unit. See illustrations below.

Check dimensions of your unit to determine model type:

	Heavy duty (FAS)	Median (FAM)
Unit Height:	18 5/8"	17 5/8"
Unit Width:	26 1/2"	23 1/2"
Min. Window Opening:	19"	18 1/2"
Min. Window Width:	31"	26 1/2"
Max. Window Width:	43"	40 1/2"

1. **Check window opening size** - the mounting parts furnished with this air conditioner are made to install in a wooden sill double-hung window. The standard parts are for window dimensions listed above. Open sash to a minimum of 19"(483mm). (FIG. 1)
2. **Check condition of window** - all wood parts of window must be in good shape and able to firmly hold the needed screws. If not, make repairs before installing unit.

FIG. 1

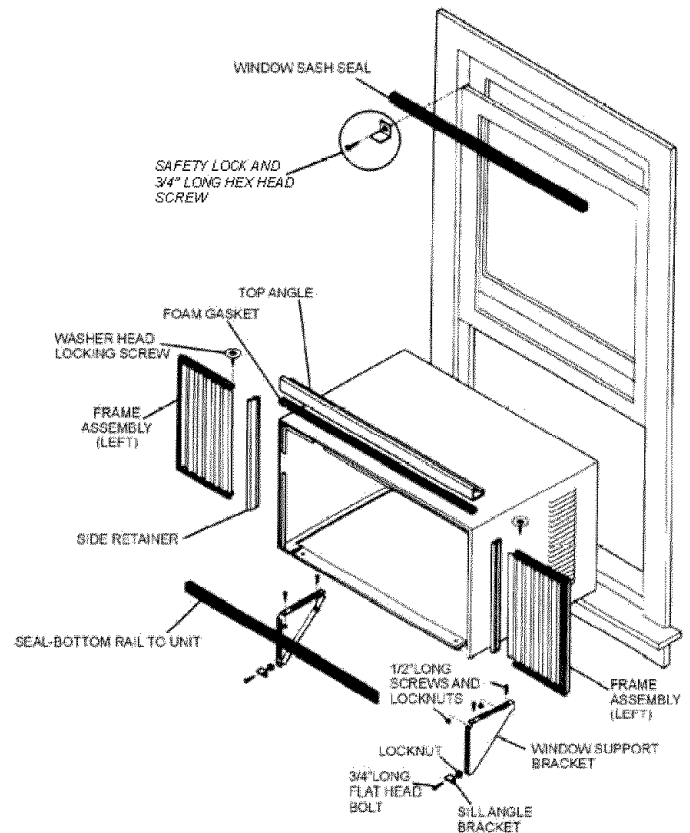
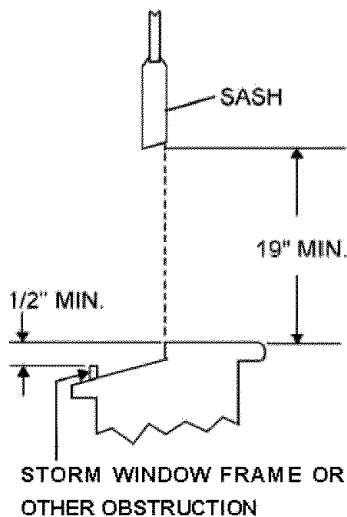

3. **Check your storm windows** - if your storm window frame does not allow the clearance required, correct by adding a piece of wood as shown in FIG. 2, or by removing storm window while room air conditioner is being installed. (continued)

FIG. 2

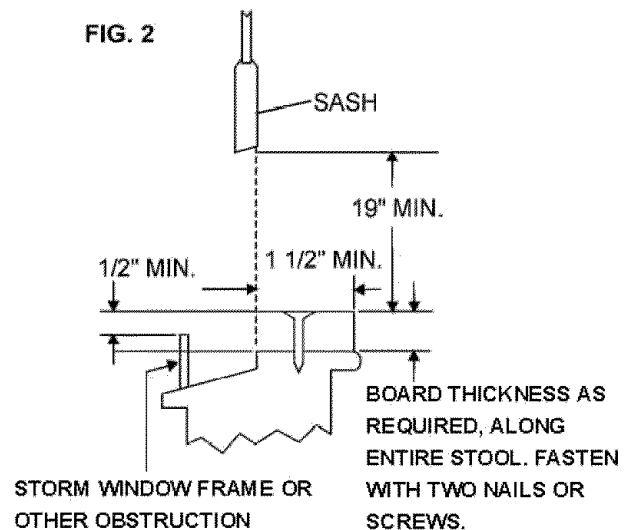

- CHECK FOR ANYTHING THAT COULD BLOCK AIRFLOW - check area outside of window for things such as shrubs, trees, or awnings. Inside, be sure furniture, drapes, or blinds will not stop proper airflow.
- Check the available electrical service - power supply must be the same as that shown on the unit serial nameplate. (See Owner's Guide for serial plate location.) Power cord is 48" long. Be sure you have an outlet near.

All models have a 3-prong service plug to provide proper service and safe positive grounding. Do not change plug in any way. Do not use an adapter plug. If your present wall outlet does not match your plug, call a qualified electrician to make the needed change.

⚠ WARNING Avoid fire hazard or electric shock. Do not use an extension cord or an adaptor plug. Do not remove any prong from the power cord.

Grounding type wall receptacle

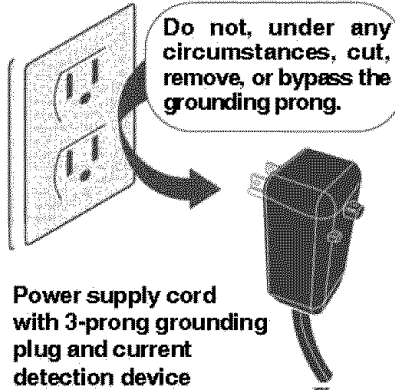

Do not, under any circumstances, cut, remove, or bypass the grounding prong.



Power supply cord with 3-prong grounding plug and current detection device

- Carefully unpack air conditioner - remove all packing material. Protect floor or carpet from damage. Two people should be used to move and install unit.

Tools Required

- ✓ a large flat blade screwdriver
- ✓ tape measure
- ✓ adjustable wrench or pliers
- ✓ pencil
- ✓ Level
- ✓ Socket wrenches
- ✓ Phillips screwdriver

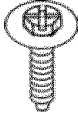
Hardware (in plastic bag)

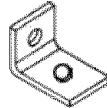
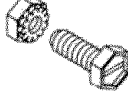
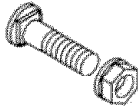
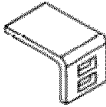
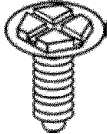
		Qty.
	Washer Head Locking Screw For window panels	2
	3/4" Long Hex-Head Screw	3
	Safety Lock	1
	1/2" Long Screw and Locknut	4 ea.
	3/4" Long Flat Head Bolt and Locknut	2 ea.
	Sill Angle Bracket	2
	Long hex-head locking screw for top angle, side retainer 5/16" Long	10

Window Mounting

1 Remove Chassis

1. Pull down front panel and remove filter. (See FIG. 1).
2. Lift front upwards and place to one side.

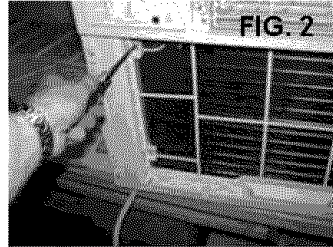
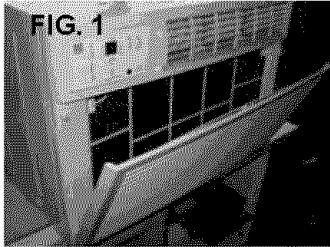

3. Locate the four front screws and remove. These screws will be needed to re-install the front later. (See FIG. 2).
4. Pry away front from cabinet sides as per photo (See FIG. 3).
5. Gently lift front off unit and place to one side (See FIG. 4).

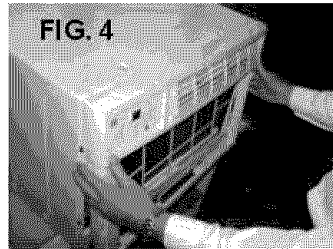
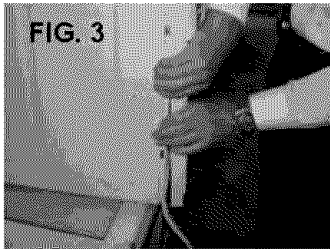

6. Remove shipping crews from top of unit and also on the side by the base if installed.
7. Hold the cabinet while pulling on the base handle, and carefully remove the unit.
8. Add two foam inserts to holes in top of cabinet where shipping screws were removed from.

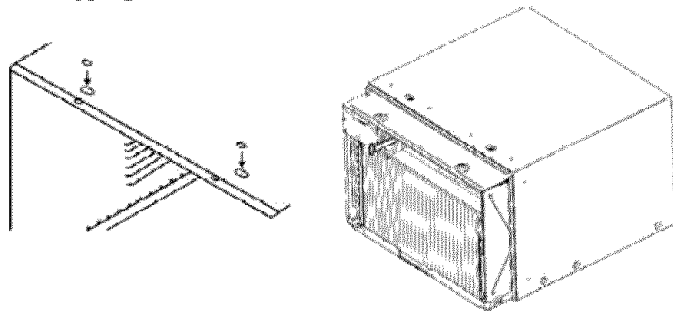

9. Your unit may come with internal packaging. **THIS PACKAGING MUST BE REMOVED PRIOR TO INSTALLING THE AIR CONDITIONER BACK INTO THE CABINET.** (See FIG. 5).

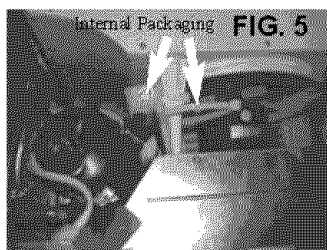

2 Install Top Angle and Side Bracket

1. Attach foam gasket to top angle above holes as shown in FIG. 6.

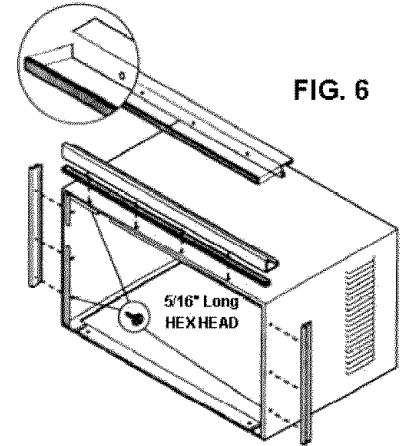

2. Install top angle and side retainers to cabinet as shown in FIG. 6.

3 Assemble Window Filler Panels

1. Place cabinet on floor, a bench, or a table.
2. Slide "T" section of window filler panel into side retainer on the side of the cabinet (see Figures 7-8). Do both sides.

FIG. 7

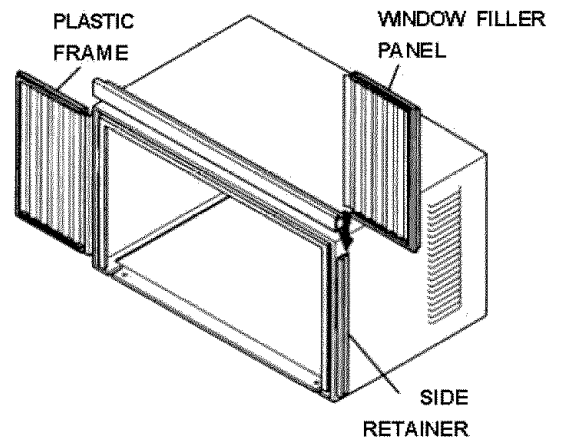
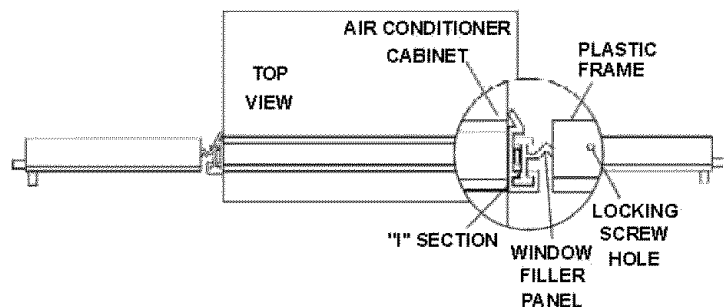

FIG. 8



3. Insert top and bottom legs of window filler panel frame into channel in the top angle and bottom rail. Do both sides.
4. Insert washer head locking screws (2) into holes in top leg of filler panel frame (see Step 6). Do not totally tighten. Allow leg to slide freely. Screws will be tightened after Section 6.

4 Place Cabinet in Window

1. Open window and mark center of window stool.

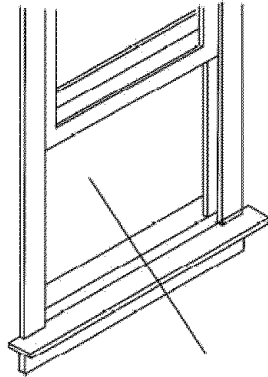

2. Place cabinet in window with bottom stool angle firmly seated over window stool as shown. Bring window down temporarily behind top angle to hold cabinet in place.

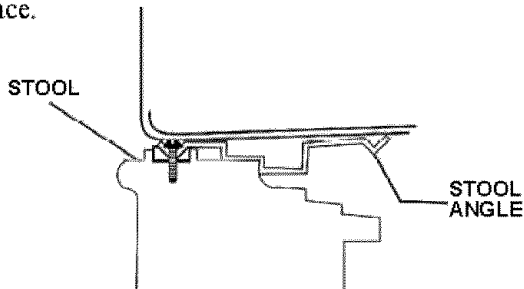

3. Shift cabinet left or right as needed to line up center of cabinet on center line marked on stool.
4. Fasten cabinet to window stool with 2 screws into holes. (You may wish to pre-drill pilot holes.)
5. Add bottom rail seal over screws to window stool.

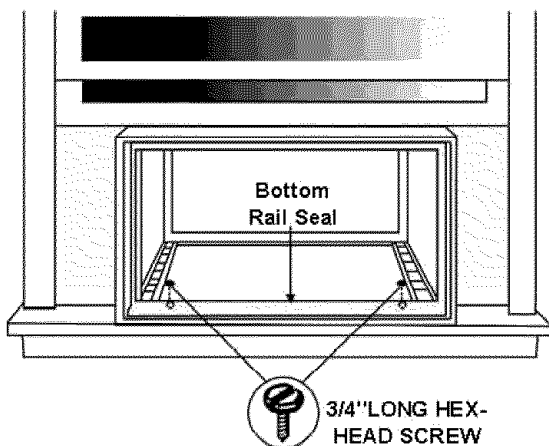

5 Install Support Bracket

1. Hold each support bracket flush against outside of sill, and tight to bottom of cabinet as shown below. Mark brackets at top level of sill, and remove.

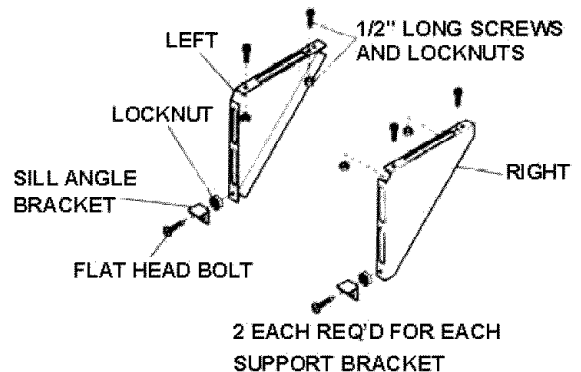
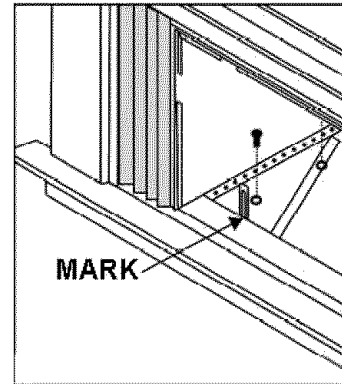

2. Assemble sill angle bracket to support brackets at the marked position, as shown. Hand tighten, but allow for any changes later.
3. Install support brackets (with sill angle brackets attached) to correct hole in bottom of cabinet as shown.
4. Tighten all 6 bolts securely.

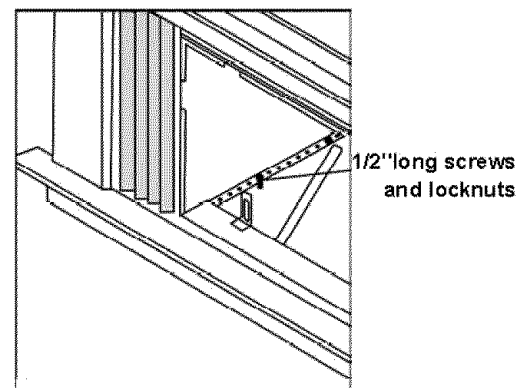

6 Extend Window Filler Panels

1. Carefully raise window to expose filler panel locking screws. Loosen screws so filler panels slide easily.

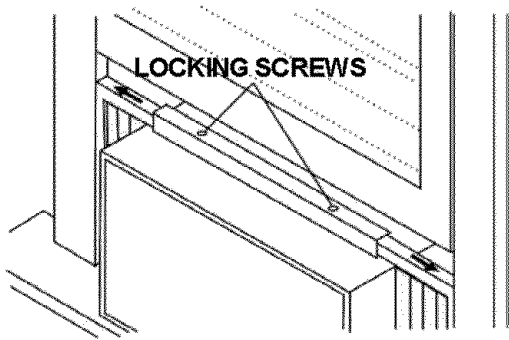

2. Extend panels to fill window opening completely. Tighten locking screws on top.
3. Close window behind top angle.

7 Install Window Lock and Sash Seal

1. Trim sash seal to fit window width. Insert into space between upper and lower sashes.

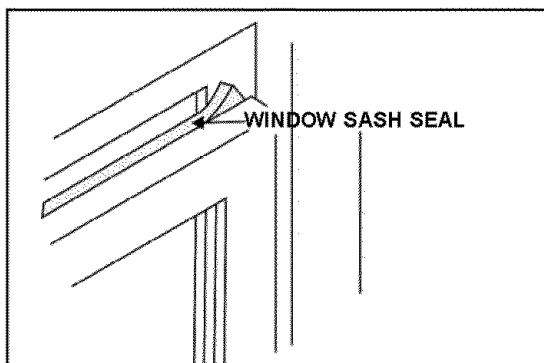

2. Attach right angle safety lock as shown.

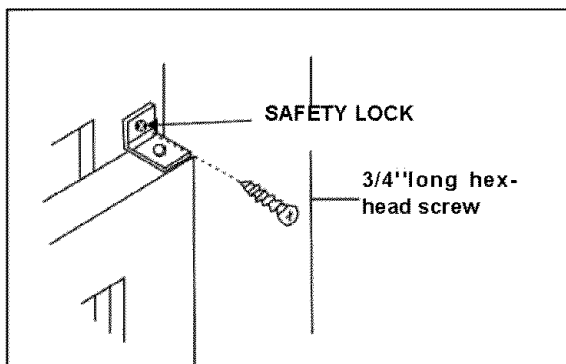

8 Install Chassis into Cabinet and Install Front to Unit

1. Lift air conditioner and carefully slide into cabinet leaving 6" protruding.
2. **CAUTION** DO not push on controls OR finned coils.
3. Be sure chassis is firmly seated towards rear of cabinet.
4. Installation of front is the reverse of removal outlined in Section 1.

Thru-The-Wall Installation

NOTE: Consult local building codes prior to installation, or a qualified carpenter.

1 Select Wall Location

This air conditioner has a slide-out chassis, so that it can be installed through an outside wall as specified below:

	Heavy Duty (FAS)	Median (FAM)
Max wall thickness	12"	10"

IMPORTANT: Side louvers must never be blocked.

NOTE: All parts needed for Thru-The-Wall Installation are provided, except a wood frame, shims, and 10 wood screws (# 10-1" long minimum). Select a wall surface that:

1. does not support major structural loads such as the frame construction at ends of windows, and under truss-bearing points, etc.
2. does not have plumbing or wiring inside.
3. is near existing electrical outlets, or where another outlet can be installed.
4. faces, and is not blocked to the area to be cooled.
5. allows unblocked airflow from rear sides and end (outside) of installed air conditioner.

2 Prepare Wall

1. Prepare wall in frame construction (including brick and stucco veneer). Working from inside the room, find wall stud nearest the center of area where air conditioner will be installed (by sounding wall, or by magnetically finding nails).
2. Cut or knock out a hole on each side of center stud.
3. Measure between inside edges of every other stud as shown in FIG. 1.

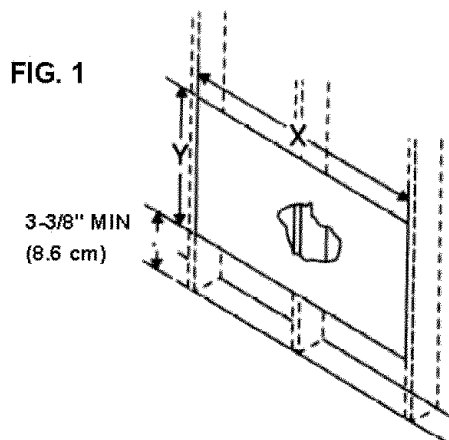

Carefully measure and cut an opening with the following dimensions depending on your model. See FIGS. 1 and 2.

WIDTH "X" = inside model width plus twice the thickness of framing material used.

HEIGHT "Y" = inside model height plus twice the thickness of framing material used.

	Heavy Duty (FAS)	Median (FAM)
Inside Frame Height:	18 ^{7/8} " (47.9cm)	18" (45.7cm)
Inside Frame Width:	26 ^{3/4} " (67.9cm)	23 ^{7/8} " (60.6cm)

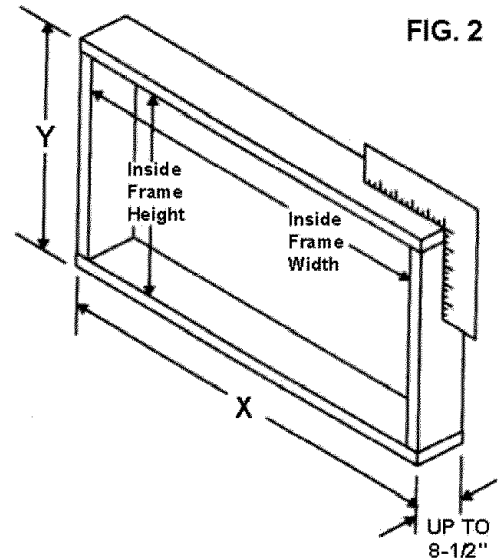

4. Build a wooden frame with the INSIDE dimensions of your model listed above. (Measure twice remember...) Frame depth should be the same as wall thickness. Fill in the space from the opening to the studs with wood spacers, as shown.
5. Nail frame to spacers to studs with front flush with drywall.

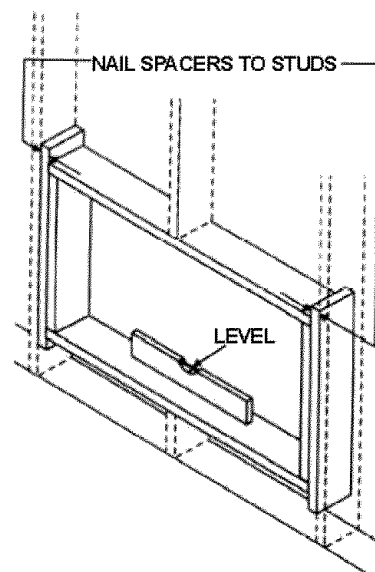

NOTE: If wall thickness is 8-1/2" or more, add aluminum flashing over bottom of frame opening to assure no water can enter area between inner and outer wall.

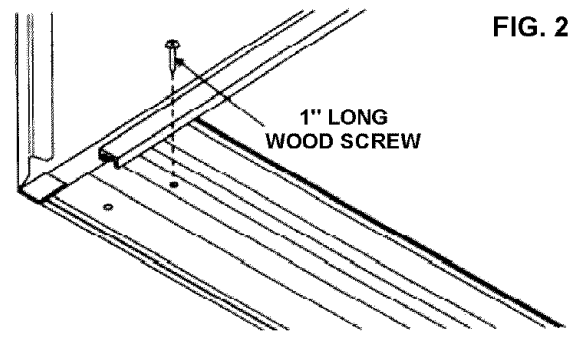
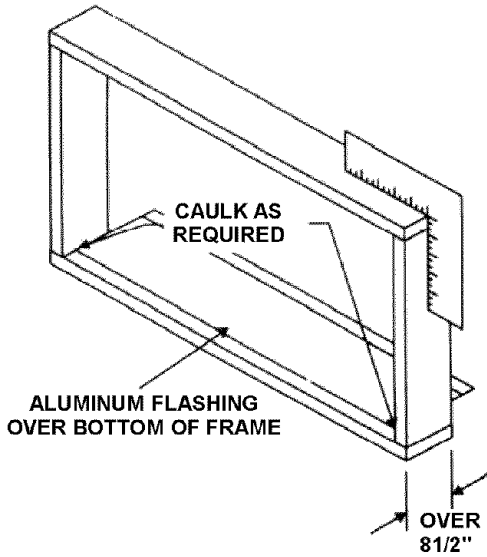

Refer to Step 4 of Window Mounting for assembly of support brackets. A wooden strip nailed to the outside wall should be used in conjunction with sill support angle brackets.

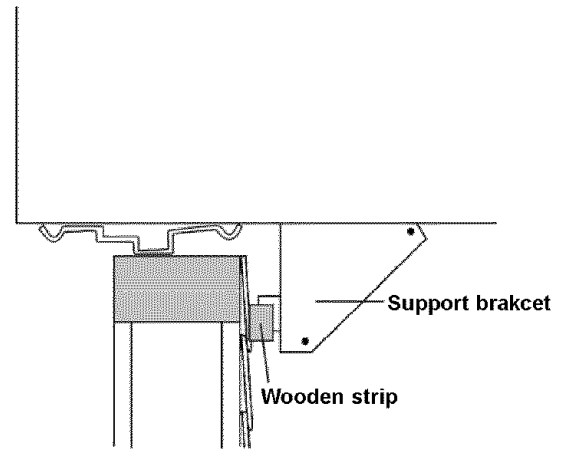

5. Screw or nail cabinet wooden frame using shims if frame is oversized, to eliminate distortion. Remember to maintain proper slope as described in Step 3.

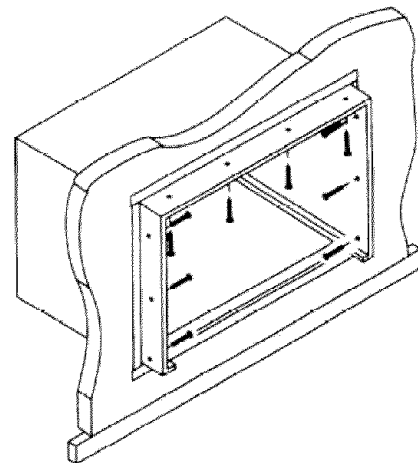

6. Install chassis into cabinet by following all steps in Step 8 of Window Mounting. (continued)

3 Prepare and Install Cabinet

1. Slide chassis from cabinet. Refer back to Step 1 of Window Mounting.
2. Place cabinet into opening with bottom rail resting firmly on bottom board of wooden frame.
3. Position cabinet to achieve proper slope for water removal. (See FIG. 1 below.)

FIG. 1

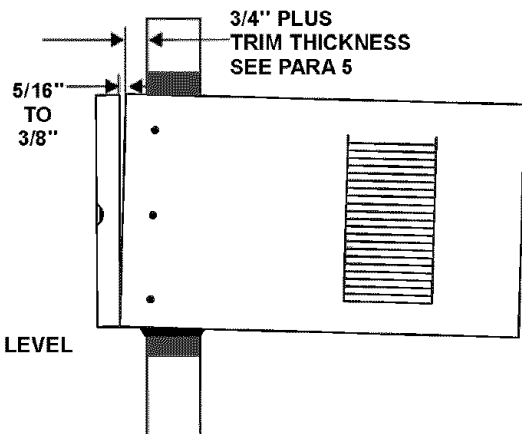

4. Secure bottom rail to wood frame with two large wood screws 1"(2.5 cm) long using the two holes in the bottom of the channel resting on frame. (See FIG. 2 following)

OPTIONAL: Caulking and installation of trim on interior wall may be done. You can buy wood from your local lumber or hardware supply. On the outside, caulk openings around top and sides of cabinet, and all sides of wood sleeve to the opening.

NOTE: See Step 7, Item 3 of Window Mounting Instructions for bottom rail seal location.

Masonry Construction

1. Cut or build a wall opening in the masonry wall similar to the frame construction (refer to Step 2 of Thru-the-Wall Installation for a wall thickness greater than 8-1/2").
2. Secure cabinet in place using masonry nails, or the right masonry anchor screws. (Another way to do this is to build an in-between frame of 2x4's as shown in the Step 2 Prepare Wall illustrations-but make it double framed on either side, and install between masonry wall opening and cabinet. Frame must be securely anchored to masonry wall opening) This way gives very good louver clearance on either side of cabinet.
3. Install a lintel to support masonry wall above cabinet. Existing holes in cabinet can be used and/or additional holes can be drilled to fasten cabinet at various positions. Be sure that side louver clearance is in accordance with Step 1 above.
4. Install exterior cabinet support brackets as shown in Step 2 of Thru-the-Wall Installation. Caulk or flash if needed, to provide a wether-tight seal around top and sides of cabinet.
5. To complete installation, apply wood trim molding around room side projection of cabinet.