

NOTE TO THE INSTALLER

After you have followed the procedures on the previous pages. Check the following.

FINAL CHECK LIST HAVE YOU CARRIED OUT THE FOLLOWING

REMOVE TRANSIT BOTTOM PACKER

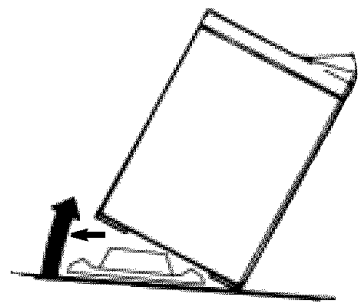

Bottom packer **MUST** be removed from the base of the washer, before the basket packer is removed.

DRAIN HOSE

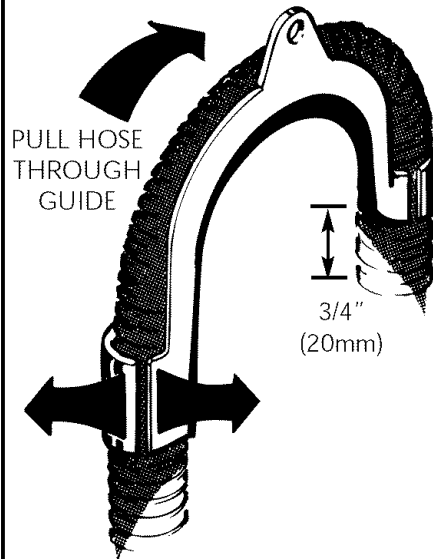

The drain hose guide **MUST** be fitted to the drain hose and should not extend more than 3/4" (20mm) from the end of the guide. Place the drain hose in tub or standpipe.

INLET HOSE CONNECTIONS

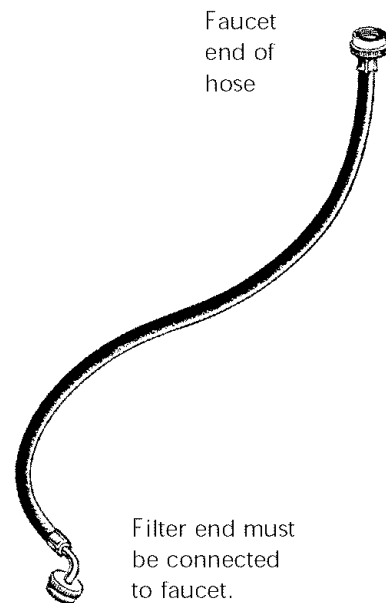

Filter end must be connected to faucet.
Washer end of hose.

LEVELING

Make sure washer is level and four rubber inserts are properly installed.

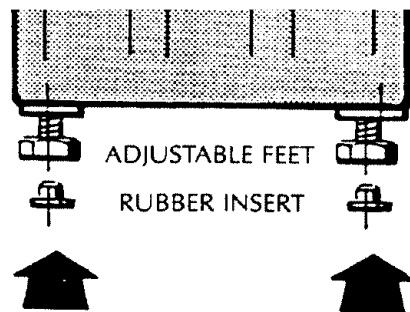

GROUNDING

MUST be properly grounded to conform to local codes and ordinances.
WARNING: Improper connection of equipment-grounding conductor can result in a risk of electric shock. Check with a qualified electrician or serviceman if you are in doubt as to whether the appliance is properly grounded.

OPERATION

1. Turn faucets on. Check for leaks, noise, vibration, correct water temperatures and proper operation in spin.
2. Turn hot and cold water faucets off and instruct customer to do the same when washer is not in use.
3. Give customer the Use & Care Book and Installation Instructions.

READ AND OBSERVE ALL SAFETY INSTRUCTIONS - CONSULT THE PRODUCT USE & CARE BOOK FOR CUSTOMER CAUTIONS

INSTALLATION INSTRUCTIONS FOR YOUR ECO SMART WASHER

BEFORE YOU BEGIN - READ THESE INSTRUCTIONS COMPLETELY AND CAREFULLY.
IMPORTANT - OBSERVE ALL GOVERNING CODES AND ORDINANCES.

Note to installer: Be sure to leave these instructions with the Customer.
Note to Consumer: Keep these instructions with your Use & Care Book for future reference.
Note: This appliance must be properly grounded.

INSTALLATION REQUIREMENTS

LOCATION

Washer must be installed on firm flooring to minimize vibration during spin cycles. Concrete flooring is best, but wood base is sufficient providing floor support meets FHA standards.

Washer should not be installed on rugs or exposed to the weather.

PLUMBING

Water Temperature

Your cold water should not exceed 95°F (35°C) or your hot water exceed 150°F (65°C). Temperatures above this may damage your washer.

Shut off valves

Both hot and cold shut-off valves (faucets) should be available in laundry area.

Drain

Water may be drained into a standpipe or set tub. The standpipe must be 1 1/2" (38mm) minimum inside diameter and must be open to the atmosphere.

ELECTRICAL

This appliance must be supplied with 110V-120V, 60Hz, and connected to an individual, properly grounded branch circuit, protected by a 15 or 20 amp circuit breaker or time delay fuse.

SPECIFICATIONS

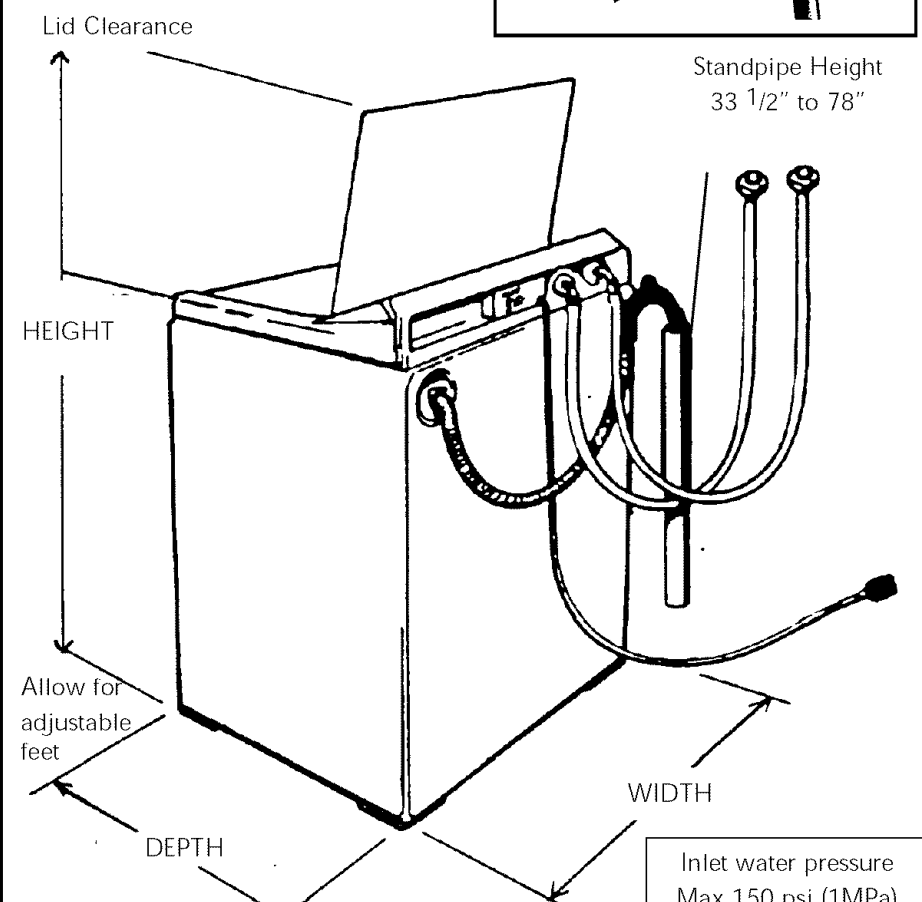
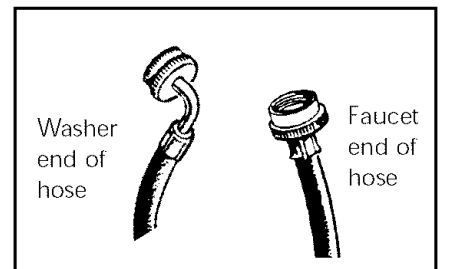

DIMENSIONS

MODEL	All models
DEPTH	25 1/2" (650mm)
WIDTH	25 1/2" (650mm)
HEIGHT to top of console	40 1/2" - 41 1/2" (1020-1050mm)
HEIGHT LID OPEN	55 1/2" - 56 1/2" (1410-1440mm)

Inlet water pressure
Max 150 psi (1MPa)
Min 3 psi (20kPa)

STEP 1

REMOVE BOTTOM PACKER

1. Remove outer packaging.
2. Tilt the machine backwards and walk the machine off the bottom packer. The plastic bottom packer can now be removed from the machine.

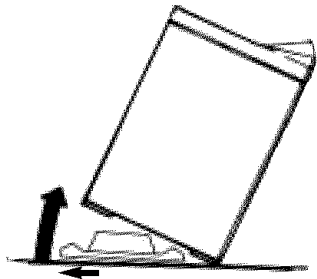

Caution: Operating the machine when the bottom packer is in place can result in damage to the machine.

STEP 2

REMOVING BASKET PACKER AND ACCESSORIES

1. Lift lid and remove cardboard basket packer from under lid.
2. Keep the bottom packer and basket packer in case they are required for future transit.
3. Remove hoses, accessories and installation pack.

The installation pack contains the following:

- 4 rubber inserts for the leveling feet
- 1 drain hose guide

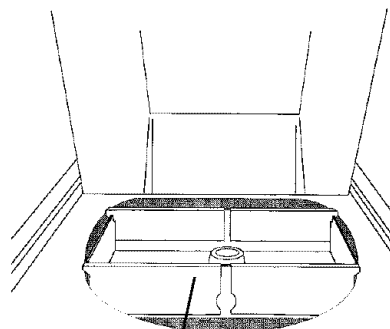

BASKET PACKER

STEP 3

Drain Hose

1. Carefully pull the drain hose out from the back of the washer by pulling the exposed part of the hose downwards and then out.
2. The hose guide is used to guide the drain hose over the tub or standpipe. It MUST be fitted to the drain hose. To prevent siphoning the drain hose should not extend more than 3/4" (20mm) from the end of the guide. If necessary, the drain hose can be trimmed to length.

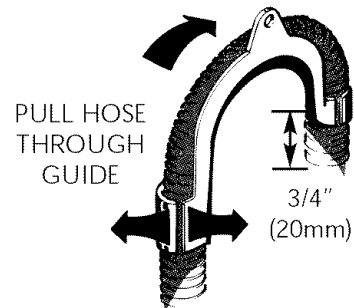

PULL HOSE THROUGH GUIDE

3. Place the drain hose in laundry tub or standpipe.

Note:

- In multi-storey apartments or any upper floor, the machine should be installed on a drained floor
- Check that the tub or standpipe is free from lint or other obstructions.
- In basement installation do not exceed standpipe height. (78")

STEP 4

Inlet Hoses

1. Install hoses with straight end (with filters) onto the faucets.
2. Install elbow ends onto washing machine (inlet valves are marked on the back of the machine H=hot, C=cold)

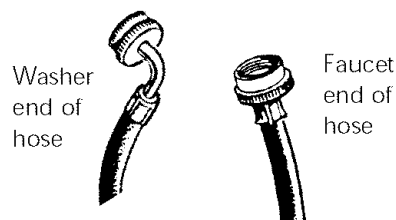

Washer end of hose

Faucet end of hose

Note: If there is a cold water supply only, an inlet valve cap (available from Fisher & Paykel) MUST be connected to the hot valve. The cap prevents water leaking out the hot valve. Cold water connection is required.

STEP 5

LEVELING THE WASHER

Leveling Feet

1. Insert the four rubber leveling feet inserts into the feet on the base of the washer.

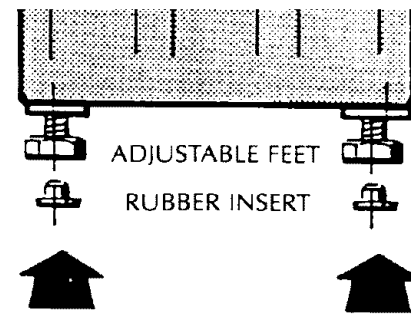

2. Move the washer into its final position. We suggest a minimum clearance of 1" (25mm) on each side for ease of installation.

1" (25mm) 1" (25mm)

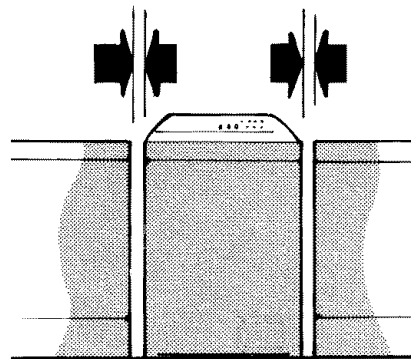

3. Turn on water and check hose connections for leaks. Make sure there are no kinks in the hoses.
4. It is IMPORTANT to level the washer to give proper performance in spin.

Make sure the rubber inserts are in the adjustable feet on the base of the washer. Adjust the feet by unscrewing/screwing to make sure the washer is level and cannot rock.

5. Use the walls and adjacent counter tops as a sight guide to check to see if washer appears level. Readjust the feet if necessary.

6. Please test machine in permanent press cycle.

7. Open lid and check the washer basket to see that it sits slightly forward of centre (see illustration).

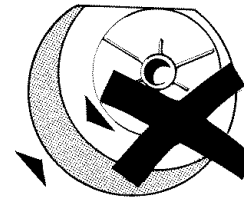

INCORRECT ADJUSTMENT

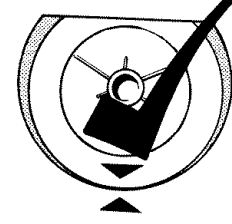

CORRECT ADJUSTMENT

8. Close the lid. Visually check that the lid and topdeck are aligned.

If it does not look like the diagram below, adjust one of the front feet slightly until it matches.

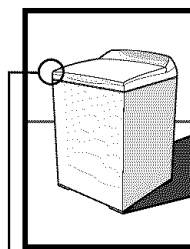

Lid Alignment

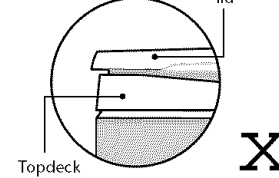
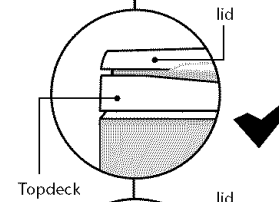
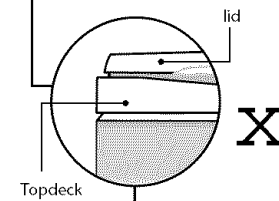

SPECIAL REQUIREMENTS FOR ALCOVE OR CLOSET INSTALLATION

The minimum ventilation clearance between the washer and adjacent walls or other surfaces is:

1" (25mm) either side and front
3" (75mm) rear

NOTE: The clearances stated are minimums. Consideration must be given to providing adequate clearance for installation and servicing.

Minimum vertical space from floor to overhead shelves, cabinets, ceilings etc is 59" (1500mm).

Closet doors must be louvered or otherwise ventilated and have at least 60 square inches open area for a washer only, or if the closet contains both a washer and dryer, doors must contain at least 120 square inches of open area equally distributed.

Caution: DO NOT INSTALL THIS APPLIANCE IN A CLOSET WITH A SOLID DOOR.

LOUVERED DOOR WASHER & DRYER

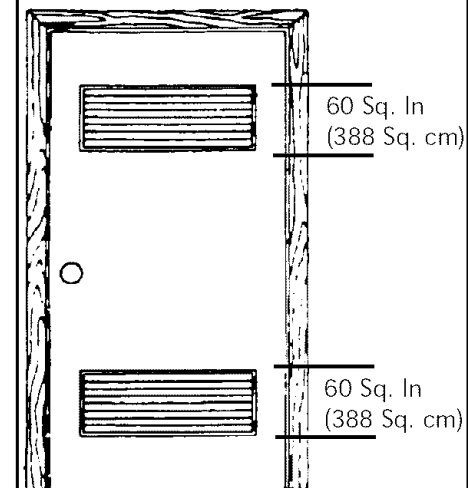

MOBILE HOME INSTALLATION

Installation must conform to STANDARD FOR MOBILE HOMES, ANSI A119.1 and NATIONAL MOBILE HOME CONSTRUCTION & SAFETY STANDARDS ACT OF 1974 (PL93-383).

GROUNDING INSTRUCTIONS

This appliance must be grounded. In the event of malfunction or break down, grounding will reduce the risk of electric shock by providing a path of least resistance for electric current. This appliance is equipped with a cord having an equipment-grounding conductor and a grounding plug. The plug must be plugged in to an appropriate outlet that is properly installed and grounded in accordance with all local codes and ordinances.

WARNING: Improper connection of equipment-grounding conductor can result in a risk of electric shock. Check with a qualified electrician or serviceman if you are in doubt as to whether the appliance is properly grounded.

Do not modify the plug provided with the appliance - if it will not fit the outlet, have a proper outlet installed by a qualified electrician.

OPERATION

1. Turn faucets on. Check for leaks, noise, vibration, correct water temperatures and proper operation in spin. Check lid locks during spin.
2. Turn hot and cold water faucets off and instruct customer to do the same when washer is not in use.
3. Give customer the USE & CARE Book and Installation Instructions.

SPECIAL INSTRUCTIONS

1. The washer may give warning signals when low water pressure, or drain problems are encountered. Consult the USE & CARE Book.
2. Note user options shown in the USE & CARE Book.

If further help is needed concerning this appliance call:
TOLL FREE 1 888 9FNP USA
(1 888 936 7872)

IN CANADA
Direct 1 877 744 7400

or write:

Fisher & Paykel Appliances Inc.,
27 Hubble, Irvine, CA 92618