

Owner's Manual

Stainless Steel
Professional
30", 36" and 48"
Dual Fuel Ranges

Natural Gas Models

ZDP48N4G

ZDP48N6R

ZDP48N6D

ZDP36N6

ZDP36N4R

ZDP36N4D

ZDP30N4

Liquid Propane Models

ZDP48L4G

ZDP48L6R

ZDP48L6D

ZDP36L6

ZDP36L4R

ZDP36L4D

ZDP30L4



Monogram®

Introduction

Your new Monogram range makes an eloquent statement of style, convenience and kitchen planning flexibility. Whether you chose it for its purity of design, assiduous attention to detail—or for both of these reasons—you'll find that your Monogram range's superior blend of form and function will delight you for years to come.

The information on the following pages will help you operate and maintain your range properly. If you have any other questions, visit our Website at: ge.com

Contents

Surface Cooking

Burners15, 16
 Controls 14, 15, 19
 Cookware17
 Dual-Flame Burners16
 Features 14
 Griddle 20, 21
 Grill 18–20

Oven

Aluminum Foil 8, 9, 24
 Baking/Roasting 22–24
 Broiling/Broiling Guide 26, 27
 Controls 14, 22, 23, 26–28
 Convection Cooking 25, 26
 Features 14
 Proofing 23
 Self-Cleaning Instructions 28, 29

Care and Cleaning

Backguards 36
 Burner Caps 33
 Burner Grates 33
 Broiler Pan and Grid 31
 Companion Standard Clean 29
 Control Panel and Knobs 30
 Drip Trays, Liners
 and Drain Tubes 34
 Griddle 35
 Grill 36
 Lift-Off Oven Door 36
 Oven Heating Elements 30
 Oven Light 31
 Sealed Burner Assemblies 32
 Self-Clean Oven Racks 36
 Stainless Steel 30

Consumer Services

Important Phone Numbers 39
 Model and Serial Number 3, 14
 Problem Solver 37, 38
 Product Registration 3, 43, 44
 Safety Instructions 2, 3, 4–13
 Warranty 42

WARNING: If the information in this manual is not followed exactly, a fire or explosion may result causing property damage, personal injury or death.

- Do not store or use gasoline or other flammable vapors and liquids in the vicinity of this or any other appliance.
- **WHAT TO DO IF YOU SMELL GAS**
 - Do not try to light any appliance.
 - Do not touch any electrical switch; do not use any phone in your building.
 - Immediately call your gas supplier from a neighbor's phone. Follow the gas supplier's instructions.
 - If you cannot reach your gas supplier, call the fire department.
- Installation and service must be performed by a qualified installer, service agency or the gas supplier.

AVERTISSEMENT : Si vous ne suivez pas exactement les informations contenues dans ce manuel, vous pouvez provoquer un incendie ou une explosion qui peut occasionner des dommages matériels, des blessures corporelles ou même la mort.

- Ne conservez ou n'utilisez jamais d'essence ou d'autres vapeurs ou liquides inflammables au voisinage de cet appareil ou de tout autre appareil ménager.
- **QUE FAIRE SI VOUS SENTEZ LE GAZ**
 - N'essayez pas d'allumer un appareil ménager.
 - Ne touchez aucun commutateur électrique; n'utilisez pas le téléphone dans votre bâtiment.
 - Appelez immédiatement votre fournisseur de gaz en utilisant le téléphone d'un voisin. Suivez les instructions du fournisseur de gaz.
 - Si vous ne pouvez pas joindre votre fournisseur de gaz, appelez les pompiers.
- L'installation et le service doivent être effectués par un installateur qualifié, un centre de service ou votre fournisseur de gaz.





⚠ WARNING

- ALL RANGES CAN TIP
- INJURY COULD RESULT
- INSTALL ANTI-TIP BRACKET PACKED INSIDE OVEN
- SEE INSTRUCTIONS



⚠ AVERTISSEMENT

- TOUTES LES CUISINIÈRES PEUVENT BASCULER
- CELA PEUT OCCASIONNER DES BLESSURES
- INSTALLEZ LE SUPPORT ANTI-BASCULEMENT EMPAQUÉTÉ À L'INTÉRIEUR DU FOUR
- CONSULTEZ LES INSTRUCTIONS

Before using your range

Read this manual carefully. It is intended to help you operate and maintain your new range properly.
Keep it handy for answers to your questions.

If you don't understand something or need more help, there is a list of toll-free consumer service numbers included in the back section of this manual.

OR

Visit our Website at: ge.com

Write down the model & serial numbers

You'll find them on a label located at the bottom of the oven, visible when the oven door is opened.

These numbers are also on the Consumer Product Ownership Registration Card included in this manual.

Before sending in this card, please write these numbers here:

Model Number

Serial Number

Use these numbers in any correspondence or service calls concerning your range.

If you received a damaged range

Immediately contact the dealer (or builder) that sold you the range.

Save time & money

Before you request service, check the Problem Solver in the back of this manual.

It lists causes of minor operating problems that you can correct yourself.

If you need service

To obtain service, see the Consumer Services page in the back of this manual.

We're proud of our service and want you to be pleased. If for some reason you are not happy with the service you receive, here are the steps to follow for further help.

FIRST, contact the people who serviced your appliance. Explain why you are not pleased. In most cases, this will solve the problem.

NEXT, if you are still not pleased, write all the details—including your phone number—to:

Manager, Customer Relations
GE Appliances
Appliance Park
Louisville, KY 40225

IMPORTANT SAFETY INSTRUCTIONS

IMPORTANT SAFETY NOTICE

- **The California Safe Drinking Water and Toxic Enforcement Act** requires the Governor of California to publish a list of substances known to the state to cause cancer, birth defects or other reproductive harm, and requires businesses to warn customers of potential exposure to such substances.
- **The fiberglass insulation in self-clean ovens gives off a very small amount of carbon monoxide during the cleaning cycle.** Exposure can be minimized by venting with an open window or using a ventilation fan or hood.
- **Gas appliances can cause minor exposure to four of these substances, namely benzene, carbon monoxide, formaldehyde and soot, caused primarily by the incomplete combustion of natural gas or LP fuels.**
Properly adjusted burners, indicated by a bluish rather than a yellow flame, will minimize incomplete combustion. Exposure to these substances can be minimized by venting with an open window or using a ventilation fan or hood.

SAFETY PRECAUTIONS

When using your appliance, follow basic safety precautions, including the following:

- **Have the installer show you the location of the range gas shut-off valve and how to turn it off if necessary.**
- **Be sure all packing materials are removed from the range before operating it to prevent fire or smoke damage should the packing material ignite.**
- **After prolonged use of a range, high floor temperatures may result and many floor coverings will not withstand this kind of use.** Never install the range over vinyl tile or linoleum that cannot withstand such use. Never install it directly over interior kitchen carpeting.
- **Locate the range out of kitchen traffic path and out of drafty locations and areas with poor air circulation.**

▲ WARNING:



All ranges can tip and injury could result. To prevent accidental tipping of the range, attach it to the wall by installing the Anti-Tip device supplied.



To check if the device is installed and engaged properly, carefully tip the range forward. The Anti-Tip device should engage and prevent the range from tipping over.

If you pull the range out from the wall for any reason, make sure the device is properly engaged when you push the range back against the wall.

If it is not, there is a possible risk of the range tipping over and causing injury if you or a child stand, sit or lean on an open door.

Please refer to the Anti-Tip information in the installation instructions.

Failure to take this precaution could result in tipping of the range and injury.

AVIS IMPORTANT DE SÉCURITÉ

- **Le California Safe Drinking Water and Toxic Enforcement Act** exige que le Gouverneur de Californie publie une liste de substances que l'on sait causer des anomalies congénitales ou d'autres déficiences de reproduction et exige que les entreprises mettent en garde leurs clients contre une exposition possible à ces substances.
- **L'isolant de fibres de verre dans les cuisinières autonettoyantes émet de toutes petites quantités de monoxyde de carbone pendant le cycle de nettoyage.** Vous pouvez réduire votre exposition à ce monoxyde de carbone en aérant, en ouvrant les fenêtres ou en utilisant une hotte ou un ventilateur d'aération.
- **Les appareils ménagers à gaz peuvent causer une exposition mineure aux substances suivantes :** le benzène, le monoxyde de carbone, le formaldéhyde et la suie, produites principalement par la combustion incomplète de gaz naturel ou de carburants de pétrole liquéfié.

Un bon réglage des brûleurs, indiqué par une flamme bleuâtre plutôt que jaune, minimise une combustion incomplète. Vous pouvez diminuer l'exposition à ces substances en aérant, en ouvrant les fenêtres ou en utilisant une hotte ou un ventilateur d'aération.

PRÉCAUTIONS DE SÉCURITÉ

Pour utiliser votre appareil ménager, vous devez prendre certaines précautions de base, en particulier les précautions suivantes :

- **Demandez à l'installateur de vous montrer l'emplacement du robinet d'alimentation de gaz de la cuisinière et la manière de couper l'alimentation de gaz si nécessaire.**
- **Assurez-vous de bien enlever tous les matériaux d'emballage de votre cuisinière avant de commencer à l'utiliser, pour éviter tout risque d'incendie ou de dommage dû à la fumée si les matériaux d'emballage prennent feu.**
- **Après tout usage prolongé de votre cuisinière, il se produit une élévation de la température du plancher et ne nombreuses couvertures de plancher ne supportent pas ce genre d'utilisation.** N'installez jamais votre cuisinière sur des carreaux de vinyle ou sur du linoléum, qui ne peuvent pas supporter ce genre d'utilisation. N'installez jamais votre cuisinière directement sur un revêtement intérieur de cuisine.
- **Ne placez jamais votre cuisinière dans un passage ou dans un emplacement venteux ou un endroit où il peut y avoir une mauvaise circulation de l'air.**

⚠ AVERTISSEMENT:



Toutes les cuisinières peuvent basculer et causer des blessures. Pour éviter que votre cuisinière bascule accidentellement, fixez-la au mur ou au plancher en installant le mécanisme anti-basculant fourni.



Pour vérifier si le mécanisme est bien installé et fixé, faites basculer avec soin la cuisinière vers l'avant. Le mécanisme anti-basculant devrait se brancher et empêcher la cuisinière de basculer vers l'avant.

Si vous écartez du mur votre cuisinière en la tirant, pour une raison quelconque, assurez-vous que le mécanisme entre bien quand vous repoussez la cuisinière contre le mur.

Autrement, vous risquez de faire basculer la cuisinière en occasionnant des blessures si un enfant se tient, est assis ou se penche sur une porte ouverte.

Veillez consulter les informations concernant le mécanisme anti-basculant dans les installations d'installation.

Si vous ne prenez pas cette précaution, vous pouvez faire basculer votre cuisinière et occasionner des blessures.

IMPORTANT SAFETY INSTRUCTIONS

SAFETY PRECAUTIONS

- **Use this appliance only for its intended use** as described in this manual.
- **Be sure your appliance is properly installed and grounded** by a qualified technician in accordance with the provided installation instructions.
- **Do not attempt to repair or replace any part of your range unless it is specifically recommended in this manual.** All other servicing should be referred to a qualified technician.
- **Before performing any service, DISCONNECT THE RANGE POWER SUPPLY AT THE HOUSEHOLD DISTRIBUTION PANEL BY REMOVING THE FUSE OR SWITCHING OFF THE CIRCUIT BREAKER.**
- **Do not leave children alone**—children should not be left alone or unattended in an area where an appliance is in use. They should never be allowed to sit or stand on any part of the appliance.
- **Do not allow anyone to climb, stand or hang on the door, kick panel, drip tray handles, or cooktop.** They could damage the range and even tip it over, causing severe personal injury.
- **Do not store flammable materials in the oven or near the cooktop.**
- **Do not store plastic, flammable liquids or combustible materials on top of the optional high shelf.**
- **CAUTION: ITEMS OF INTEREST TO CHILDREN SHOULD NOT BE STORED IN CABINETS ABOVE A RANGE OR ON THE BACKSPASH OF A RANGE—CHILDREN CLIMBING ON THE RANGE TO REACH ITEMS COULD BE SERIOUSLY INJURED.**
- **For your safety, never use your appliance for warming or heating the room.**
- **Never wear loose-fitting or hanging garments while using the appliance.** Be careful when reaching for items stored over the range. Flammable material could be ignited if brought in contact with surface burners, burner grates or oven heating elements and may cause severe burns.
- **Use only dry pot holders**—moist or damp pot holders on hot surfaces may result in burns from steam. Do not let pot holders touch surface burners, burner grates or oven heating elements. Do not use a towel or other bulky cloth.
- **When surface cooking, do not touch the surface burners, burner grates, grill or griddle (on some models) or the surrounding areas.**

When using the oven, do not touch the oven heating elements, the interior surface of the oven or the exterior area immediately surrounding the door or back trim.

These surfaces may be hot enough to burn.

During and after use, do not touch, or let clothing or other flammable materials contact, the surface burners, grill or griddle (on some models), areas near the surface burners, or any interior area of the oven; allow sufficient time for cooling first.

Potentially hot surfaces include the cooktop, areas facing the cooktop, oven vent opening, surfaces near the opening, crevices around the oven door, the drip tray handles directly above the oven door, metal trim parts above the door, or any backguard or high shelf surface.

The drip trays get hot when the oven is on. Do not remove the drip trays until they are cool.

CAUTION: The inside surface of the oven may be hot when the door is opened.
- **Keep the ventilator hood and grease filters clean to maintain good venting and to avoid grease fires.** Turn the ventilator OFF in case of fire or when intentionally “flaming” liquor or other spirits on the cooktop. The blower, if in operation, could spread the flames.
- **DO NOT obstruct the flow of combustion or ventilation air to the appliance.** Be sure a fresh air supply is available.
- **Cook meat and poultry thoroughly**—meat to at least an **INTERNAL** temperature of **160°F** and poultry to at least an **INTERNAL** temperature of **180°F**. Cooking to these temperatures usually protects against foodborne illness.

PRÉCAUTIONS DE SÉCURITÉ

- **N'utilisez cet appareil qu'aux fins prévues** décrites dans ce Manuel du propriétaire.
- **Assurez-vous que votre appareil soit bien installé et mis à la terre** par un technicien qualifié conformément aux instructions d'installation fournies.
- **N'essayez jamais de réparer ou de remplacer une pièce de votre cuisinière, à moins que nous ne le recommandions spécifiquement dans ce manuel.** Tout autre entretien ou réparation doit être effectué par un technicien qualifié.
- **Avant d'effectuer un entretien ou une réparation, DÉBRANCHEZ L'ALIMENTATION DE COURANT DE VOTRE CUISINIÈRE AU NIVEAU DU TABLEAU DE DISJONCTEURS DE LA MAISON, EN ENLEVANT LE FUSIBLE OU EN FAISANT BASCULER LE DISJONCTEUR.**
- **Ne laissez jamais des enfants sans surveillance**— vous ne devez jamais laisser des enfants seuls ou sans surveillance dans un emplacement où un appareil ménager est utilisé. Vous ne devez jamais leur permettre de s'asseoir ou de monter sur une partie de l'appareil ménager.
- **Ne permettez à personne de grimper, de se tenir ou de se suspendre sur la porte de votre cuisinière, son panneau de bas de porte, les poignées de son égouttoir ou sa table de cuisson.** Cette personne peut endommager la cuisinière et même la faire basculer, en occasionnant des blessures corporelles sévères.
- **Ne rangez jamais de matières inflammables dans le four ou à proximité de la table de cuisson.**
- **Ne rangez jamais de matière plastique, de liquide inflammable ou de matériau combustible sur l'étagère en option.**
- **MISE EN CAUSE : VOUS NE DEVEZ JAMAIS RANGER DES ARTICLES QUI RISQUENT D'INTÉRESSER LES ENFANTS DANS DES ARMOIRES SITUÉES AU-DESSUS DE VOTRE CUISINIÈRE OU SUR LE DOSSERET DE VOTRE CUISINIÈRE. DES ENFANTS QUI MONTENT SUR LA CUISINIÈRE POUR ATTEINDRE CES ARTICLES PEUVENT ÊTRE SÉRIEUSEMENT BLESSÉS.**
- **Pour votre sécurité, n'utilisez jamais votre appareil ménager pour réchauffer la pièce.**
- **Ne portez jamais de vêtements lâches ou traînants quand vous utilisez votre cuisinière.** Faites attention quand vous allez chercher des articles qui sont rangés au-dessus de votre cuisinière. Des matières inflammables peuvent prendre feu si elles sont mises en contact avec les brûleurs de surface, les grilles de brûleur ou les éléments de chauffage du four et peuvent occasionner des brûlures sérieuses.
- **N'utilisez que des poignées de casserole sèches.** Des poignées de casseroles humides ou mouillées sur des surfaces chaudes peuvent occasionner des brûlures dues à la vapeur. Ne laissez jamais de poignée de casserole s'approcher des brûleurs de surface, des grilles de brûleur ou des éléments de chauffage du four. N'utilisez jamais de serviette ou de linge épais à la place d'une poignée de casserole.
- **Quand vous cuisez en surface, ne touchez jamais les brûleurs de surface, les grilles de brûleur, la grille ou le grill (sur certains modèles), ni les surfaces avoisinantes.**

Quand vous utilisez le four, ne touchez jamais les éléments de chauffage du four, la surface intérieure du four ou la surface extérieure entourant directement la porte ou la garniture arrière.

Ces surfaces peuvent être chaudes et vous brûler. Pendant et après toute utilisation, ne touchez jamais, ou ne laissez jamais vos vêtements ou tout autre matériau inflammable en contact avec les brûleurs de surface, la grille ou le grill (sur certains modèles), les surfaces avoisinant les brûleurs de surface, ou toute surface intérieure du four; laissez-les suffisamment de temps pour se refroidir.

Les surfaces qui peuvent être chaudes comprennent la table de cuisson, les surfaces en face de la table de cuisson, les ouvertures des événements du four, les surfaces avoisinant ces ouvertures, les fentes autour de la porte du four, les poignées de l'égouttoir situées directement au-dessus de la porte du four, les pièces de garniture en métal situées au-dessus de la porte ou toute surface du dossier ou de la clayette supérieure.

Les égouttoirs se réchauffent quand le four est en marche. N'enlevez les égouttoirs que quand ils ont refroidi.

MISE EN CAUSE : La surface intérieure du four peut être chaude quand vous ouvrez la porte.
- **Il faut que votre hotte et vos filtres à graisse soient toujours propres pour assurer une bonne ventilation et éviter les incendies de graisses.** Mettez toujours le ventilateur en position OFF (arrêt) en cas de feu ou quand vous faites flamber intentionnellement des liqueurs ou d'autres alcools sur votre table de cuisson. Le ventilateur en fonctionnement peut répandre les flammes.
- **NE gênez JAMAIS la circulation d'air de combustion ou de ventilation allant à votre appareil ménager.** Assurez-vous de toujours avoir un courant d'air frais.
- **Faites bien cuire vos viandes et vos volailles— Faites cuire vos viandes à une température INTERNE d'au moins 160°F et vos volailles à une température INTERNE d'au moins 180°F.** La cuisson à ces températures protège en général contre les maladies alimentaires.

IMPORTANT SAFETY INSTRUCTIONS

SAFETY PRECAUTIONS

- **Do not use water on grease fires. Never pick up a flaming pan.** Turn the controls off. Smother a flaming pan on a surface unit by covering the pan completely with a well-fitting lid, cookie sheet or flat tray. Use a multi-purpose dry chemical or foam-type fire extinguisher.

Flaming grease outside a pan can be put out by covering it with baking soda or, if available, by using a multi-purpose dry chemical or foam-type fire extinguisher.

Flame in the oven can be smothered completely by closing the oven door and turning the oven off or by using a multi-purpose dry chemical or foam-type fire extinguisher.
- **DO NOT STORE OR USE COMBUSTIBLE MATERIALS, GASOLINE OR OTHER FLAMMABLE VAPORS AND LIQUIDS IN THE VICINITY OF THIS OR ANY OTHER APPLIANCE.**
- **Do not let cooking grease or other flammable materials accumulate in or near the range.** Clean drip trays and liners after every use.
- **If you smell gas,** the installer has not done a proper job of checking for leaks. You can have a small leak and therefore a faint gas smell if the connections are not completely tight.

Finding a gas leak is **NOT** a do-it-yourself procedure. Some leaks can only be found with the burner control in the ON position and for your protection it must be done by a qualified service technician. Never use an open flame to locate a leak.
- **If by some chance a burner goes out and gas escapes, open a window or a door to let the room air out.** Do not attempt to use the appliance until the gas has had time to dissipate. Follow the instructions in "What to do if You Smell Gas" on page 2.
- **Do not use aluminum foil to line any part of the oven or cooktop.** Using a foil liner could result in a fire hazard or the obstruction of the flow of combustion and ventilation air. Foil is an excellent heat insulator and heat will be trapped underneath it. This trapped heat can upset the cooking performance and can damage the finish of the oven or the cooktop.

SURFACE COOKING

- **Do not heat unopened food containers;** a build-up of pressure may cause the container to burst.
- **Set the burner control so that the flame heats only the bottom of the pan** and does not extend beyond the bottom of the pan. Excessive flame is hazardous. The high BTU burners can easily melt cookware handles.
- **Hold the handle of the pan, using a dry pot holder,** to prevent movement of the utensil when stirring or turning food.
- **Always heat fat slowly, and watch as it heats.**
- **Always use the LITE position when igniting the surface burners** and make sure the burners have ignited.
- **Never leave the surface burners unattended at high flame settings.** Boilovers cause smoking and greasy spillovers that may catch on fire. If the burner flames are smothered by a severe boilover which affects the ignitor, unburned gas will escape into the room.
- **Do not let pot holders come near open flames when lifting cookware.** Do not use a towel or other bulky cloth in place of a pot holder.
- **To minimize the possibility of burns,** ignition of flammable materials and spillage, turn cookware handles toward the side or back of the range without extending over adjacent burners.
- **Never block the vents (air openings) of the range.** They provide the air inlet and outlet that are necessary for the range to operate properly with correct combustion. Air openings are located at the top and bottom of the oven door, in the front portion of the drip tray and at the bottom of the backguard.

PRÉCAUTIONS DE SÉCURITÉ

- **N'utilisez jamais d'eau sur les feux de graisse. Ne soulevez jamais une casserole en flammes.** Mettez tous les boutons de réglage en position OFF (arrêt). Arrêtez les flammes d'une casserole placée sur un brûleur de surface en la recouvrant complètement d'un couvercle bien ajusté, d'une tôle à biscuits ou d'un plateau plat. Utilisez un extincteur d'incendie polyvalent à mousse ou à poudre.
Vous pouvez éteindre de la graisse en flamme sortie d'une casserole en la couvrant de bicarbonate de soude ou, si possible, en utilisant un extincteur d'incendie polyvalent à mousse ou à poudre.
Vous pouvez éteindre des flammes dans le four en fermant la porte du four et en mettant tous les boutons de réglage en position OFF (arrêt) ou en utilisant un extincteur d'incendie polyvalent à mousse ou à poudre.
- **NE RANGEZ JAMAIS OU N'UTILISEZ JAMAIS DE MATIÈRE COMBUSTIBLE, D'ESSENCE OU D'AUTRE VAPEUR OU LIQUIDE INFLAMMABLE À PROXIMITÉ DE CET APPAREIL OU DE TOUT AUTRE APPAREIL MÉNAGER.**
- **Ne laissez jamais de graisse de cuisson ou d'autre matière inflammable s'accumuler dans votre cuisinière ou à proximité de votre cuisinière.** Nettoyez après chaque utilisation les égouttoirs et les revêtements intérieurs.
- **Si vous sentez le gaz**, c'est que l'installateur n'a pas bien vérifié les fuites. Il est possible que vous ayez une petite fuite et par conséquent une faible odeur de gaz si les raccords ne sont pas complètement étanches.
Vous **NE** pouvez **PAS** localiser vous-même une fuite de gaz. On ne peut trouver certaines fuites qu'avec les boutons de contrôle des brûleurs en position ON (marche). Pour votre protection, c'est un technicien qualifié qui doit localiser toute fuite. N'essayez jamais de localiser une fuite à l'aide d'une flamme.
- **Si, par hasard, un brûleur s'éteint et du gaz s'échappe, ouvrez une fenêtre ou une porte pour laisser sortir l'air de la pièce.** N'essayez jamais d'utiliser votre appareil ménager avant que tout le gaz se soit dissipé. Suivez les instructions de la page 2 "Que faire si vous sentez le gaz."
- **N'utilisez jamais de papier d'aluminium pour recouvrir un élément du four ou de la table de cuisson.** L'utilisation de papier d'aluminium peut occasionner un incendie ou un arrêt de la circulation d'air de combustion et de ventilation. Le papier d'aluminium est un excellent isolant de la chaleur et prend au piège toute la chaleur. Cette chaleur prise au piège peut gêner la cuisson et endommager le fini du four ou de la table de cuisson.

CUISSON DE SURFACE

- **Ne réchauffez pas de contenants d'aliments fermés;** une augmentation de pression peut faire exploser le contenant.
 - **Ajustez la taille de la flamme du brûleur de surface de manière à ce qu'elle ne dépasse pas le fond de la casserole.** Une trop grande flamme est dangereuse. Les brûleurs forts peuvent facilement faire fondre les poignées de casserole.
 - **Tenez la casserole par sa poignée, à l'aide d'un torchon sec,** pour éviter tout mouvement de l'ustensile quand vous remuez ou touillez des aliments.
 - **Réchauffez toujours doucement les matières grasses, et surveillez-les quand elles chauffent.**
 - **Utilisez toujours le réglage en position LITE (allumage) quand vous allumez les brûleurs de surface** et assurez-vous que les brûleurs aient bien pris feu.
 - **Ne laissez jamais vos brûleurs de surface sans surveillance à un réglage de flammes élevées.** Les liquides bouillants causent des débordements fumants et gras qui peuvent prendre feu.
- Si les brûleurs sont éteints par un débordement important qui touche l'allumage, du gaz peut s'échapper dans la pièce.
- **Ne laissez jamais de poignée de casserole s'approcher des flammes quand vous soulevez une casserole.** N'utilisez jamais de serviette ou de linge épais à la place d'une poignée de casserole.
 - **Pour minimiser la possibilité de brûlures,** d'ignition de matériel inflammable et de renversement, tournez les poignées de casserole vers le côté ou l'arrière de la cuisinière sans les laisser dépasser sur des brûleurs adjacents.
 - **Ne bloquez jamais les événements (ouvertures d'aération) de votre cuisinière.** Ils fournissent l'entrée et la sortie d'air nécessaires pour permettre à votre cuisinière de fonctionner avec une bonne combustion. Les ouvertures d'aération sont situées en haut et en bas de la porte du four, devant l'égouttoir et en bas du dossier.

IMPORTANT SAFETY INSTRUCTIONS

SURFACE COOKING

- **Always turn the surface burners to OFF before removing cookware.**
- **Carefully watch foods being fried at a high flame setting.**
- **Foods for frying should be as dry as possible.** Frost on frozen foods or moisture on fresh foods can cause hot fat to bubble up and over the sides of the pan.
- **Use the least possible amount of fat for effective shallow or deep fat frying.** Filling the pan too full of fat can cause spillovers when food is added.
- **Use a deep fat thermometer** whenever possible to prevent overheating fat beyond the smoking point.
- **Never try to move a pan of hot fat,** especially a deep fat fryer. Wait until the fat is cool.
- **When using glass cookware,** make sure it is designed for top-of-range cooking.
- **If a combination of oils or fats will be used in frying,** stir together before heating or as fats melt slowly.
- **Do not leave any items on the cooktop.** The hot air from the vent may ignite flammable items and will increase pressure in closed containers, which may cause them to burst.
- **Use proper pan size**—avoid pans that are unstable or easily tipped. Select cookware having flat bottoms large enough to properly contain food and avoid boilovers and spillovers and large enough to cover burner grate. This will both save cleaning time and prevent hazardous accumulations of food, since heavy spattering or spillovers left on the range can ignite. Use pans with handles that can be easily grasped and remain cool.
- **Keep all plastics away from the top burners.**
- **Do not leave plastic items on the cooktop**—they may melt if left too close to the vent.
- **To avoid the possibility of a burn,** always be certain that the controls for all burners are at the OFF position and all grates are cool before attempting to remove them.
- **Do not flame foods on the cooktop. If you do flame foods under the hood, turn the fan on.**
- **Grease is flammable.** Let hot grease cool before attempting to handle it. Avoid letting grease deposits collect in the grill or the griddle drip trays. Clean these areas after each use.
- **For proper lighting and performance of the cooktop burners, keep the burner ports clean.** It may be necessary to clean these when there is a boilover or when the burner does not light, even though the electronic ignitors click.
- **After cleaning, it is important to make sure the cap and burner port are properly aligned with the burner base.** Incorrect alignment will produce poor burner performance. Never operate the burner without all burner parts in place.
- **Clean the cooktop with caution.** Avoid steam burns; do not use a wet sponge or cloth to clean the cooktop while it is hot. Some cleaners produce noxious fumes if applied to a hot surface. Follow manufacturer's directions.
- **Do not use the grill for cooking excessively fatty meats or products which promote flare-up.**
- **If range is located near a window,** do not hang long curtains that could blow over the surface burners and create a fire hazard.
- **Be sure all the range and/or cooktop controls are turned off and the appliance is cool** before using any type of aerosol cleaner or cooking spray on or around the appliance. The chemical that produces the spraying action could, in the presence of heat, ignite or cause metal parts to corrode.

CUISSON DE SURFACE

- **Mettez toujours les boutons de contrôle des brûleurs en position OFF (arrêt) avant d'enlever les ustensiles de cuisine.**
- **Surveillez bien les fritures d'aliments à réglage de flammes élevées.**
- **Les aliments à frire doivent être aussi secs que possible.** Le givre sur les aliments surgelés ou l'humidité sur les aliments frais peuvent occasionner un bouillonnement de matières grasses chaudes et un débordement de la casserole.
- **Utilisez le moins de matière grasse possible pour faire frire en friture profonde ou basse.** Si vous mettez trop de matière grasse, cela peut occasionner des débordements si vous ajoutez des aliments.
- **Utilisez autant que possible un thermomètre profond** à matières grasses pour empêcher les matières grasses de surchauffer au-delà du point de fumée.
- **N'essayez jamais de déplacer une casserole de matière grasse chaude,** en particulier une friteuse à friture profonde. Attendez que la matière grasse soit refroidie.
- **Quand vous utilisez une casserole de verre,** assurez-vous qu'elle soit conçue pour la cuisson sur table de cuisson.
- **Si vous utilisez une combinaison d'huiles ou de matières grasses pour vos fritures,** mélangez bien avant de chauffer ou pendant que les matières grasses fondent doucement.
- **Ne laissez aucun article sur la table de cuisson.** L'air chaud en provenance de l'événement peut mettre feu à des articles inflammables et augmenter la pression dans des contenants fermés, qui peuvent exploser.
- **Utilisez toujours la bonne taille de casserole.** Évitez les casseroles qui sont instables ou qui peuvent être facilement renversées. Choisissez des casseroles qui ont des fonds plats suffisamment grands pour couvrir la grille du brûleur. Pour éviter tout renversement, assurez-vous que la casserole soit suffisamment grande pour bien contenir toute la nourriture. Cela économise du temps de cuisson et empêche des accumulations dangereuses d'aliments, car des renversements ou des débordements importants sur votre cuisinière peuvent prendre feu. Utilisez des casseroles qui ont des poignées qui sont facilement saisies et restent froides.
- **Éloignez toujours les articles en matière plastique des brûleurs de surface.**
- **Ne laissez jamais d'article en matière plastique sur la table de cuisson.** Il peut fondre s'il se trouve trop près de l'événement.
- **Pour éviter toute possibilité de brûlure,** assurez-vous toujours que les contrôles de tous les brûleurs se trouvent en position OFF (arrêt) et que toutes les grilles soient froides avant d'essayer de les enlever.
- **Ne flambez pas les aliments sur la surface de cuisson.** Si vous le faites sous la hotte, mettez le ventilateur en marche.
- **La graisse est inflammable.** Laissez refroidir les matières grasses chaudes avant d'essayer de les traiter. Évitez de laisser des dépôts de matière grasse s'accumuler dans le gril ou l'égouttoir. Nettoyez ces surfaces après chaque usage.
- **Pour bien allumer et faire fonctionner les brûleurs de la table de cuisson, conservez les orifices de brûleur propres.** Vous devrez peut-être les nettoyer s'il y a un débordement ou si les brûleurs ne s'allument pas, même si les allumeurs électroniques cliquent.
- **Après les avoir nettoyés, vous devez bien aligner le capuchon et l'orifice du brûleur à la base du brûleur.** Si vous ne les alignez pas bien, vous obtiendrez un mauvais rendement du brûleur. Ne faites jamais fonctionner un brûleur si toutes ses pièces ne sont pas bien placées.
- **Faites attention quand vous nettoyez la table de cuisson.** Évitez les brûlures dues à la vapeur. N'utilisez jamais d'éponge ou de linge mouillé pour nettoyer la table de cuisson quand elle est chaude. Certains détergents produisent des émanations délétères en contact d'une surface chaude. Suivez les instructions du fabricant.
- **N'utilisez jamais le gril pour cuire des aliments excessivement gras ou des produits qui favorisent la flambée.**
- **Si la cuisinière est placée près d'une fenêtre,** ne pendez pas de rideaux longs qui peuvent s'envoler sur les brûleurs de surface et prendre feu.
- **Assurez-vous que tous les boutons de réglage du four et/ou de la table de cuisson soient en position OFF (arrêt) et que votre appareil ménager soit froid** pour utiliser un produit nettoyant en aérosol ou un aérosol de cuisine sur ou autour de l'appareil. Les produits qui vaporisent peuvent, en présence de chaleur, s'enflammer ou corroder les pièces métalliques.

IMPORTANT SAFETY INSTRUCTIONS

OVEN

- **Stand away from the range when opening the oven door.** Hot air or steam which escapes can cause burns to hands, face and/or eyes.
- **Never open door broil.** Open door broiling is not permitted due to excessive control knob temperatures.
- **Children in walkers, or children crawling, can be attracted to the round oven door handle and may grab and open the oven door.** This can result in injury from the door being pulled open on a child, or severe burns if the oven is in use and hot.
- **Do not heat unopened food containers.** Pressure could build up and the container could burst, causing an injury.
- **Keep the oven vent unobstructed.**
- **Keep the oven free from grease buildup.**
- **Place the oven rack in the desired position while the oven is cool.** If racks must be handled when hot, do not let pot holder contact the heating elements.
- **Slide the oven rack out to the stop position.** This will provide additional clearance to hot oven walls and make it easier to lift out heavy or large dishes.
- **When using cooking or roasting bags in the oven, follow the manufacturer's directions.**
- **Do not use your oven to dry newspapers.** If overheated, they can catch on fire.
- **Do not use oven for a storage area.** Items stored in an oven can ignite.
- **Do not leave paper products, cooking utensils or food in the oven when not in use.**

SELF-CLEANING OVEN

- **Do not clean the door gasket.** The door gasket is essential for a good seal. Care should be taken not to rub, damage or move the gasket.
- **Do not use oven cleaners.** No commercial oven cleaner or oven liner protective coating of any kind should be used in or around any part of the oven. Residue from oven cleaners will damage the inside of the oven when the self-clean cycle is used.
- **Clean only parts listed in this Owner's Manual.**
- **Before self-cleaning the oven, remove the broiler pan and other cookware.**
- **Be sure to wipe up excess spillage before starting the self-cleaning operation.**

SAVE THESE INSTRUCTIONS

AVIS IMPORTANT DE SÉCURITÉ

FOUR

- **Écartez-vous de la cuisinière quand vous ouvrez la porte du four.** L'air chaud ou la vapeur qui s'échappe peut vous brûler les mains, le visage et/ou les yeux.
- **N'ouvrez jamais la porte quand vous grillez.** Vous ne pouvez pas ouvrir la porte quand vous grillez à cause des températures excessives du bouton de réglage.
- **Les enfants dans des marchettes, ou les enfants à quatre pattes, peuvent être attirés par la poignée ronde de la porte du four et peuvent la saisir et ouvrir la porte du four.** Cela peut occasionner des blessures quand la porte s'ouvre sur l'enfant, ou des brûlures graves si le four est en fonctionnement et est chaud.
- **Ne réchauffez pas de contenants d'aliments fermés;** une augmentation de pression peut faire exploser le contenant, en occasionnant des blessures.
- **Ne bloquez jamais l'évent du four.**
- **Empêchez les matières grasses de s'accumuler dans le four.**
- **Placez la clayette du four en position désirée quand le four est froid.** Si vous devez déplacer la clayette quand elle est chaude, ne laissez pas le gant porteur de casserole entrer en contact avec les éléments chauffants.
- **Faites sortir la clayette du four en la faisant glisser en position d'arrêt.** Cela fournira un espace supplémentaire aux parois chaudes du four et facilitera le déplacement de plats lourds ou de grande taille.
- **Quand vous utilisez des sacs de cuisson ou de rôtissage dans le four,** suivez les instructions du fabricant.
- **N'utilisez jamais le four pour faire sécher des journaux.** Surchauffés, les journaux peuvent prendre feu.
- **N'utilisez jamais le four comme espace de rangement.** Les articles rangés dans un four peuvent prendre feu.
- **Ne laissez jamais dans le four des papiers, des ustensiles de cuisine ou des aliments quand vous ne l'utilisez pas.**

FOUR AUTONETTOYANT

- **Ne nettoyez jamais le joint de la porte.** Le joint de la porte est essentiel à une bonne fermeture du four. Vous devez bien prendre garde de ne pas frotter, endommager ou déplacer ce joint.
- **N'utilisez jamais de produit nettoyant de four.** N'utilisez jamais de nettoyant de four commercial ou de revêtement protecteur de four dans votre four ou autour d'une partie de votre four. Les résidus de nettoyeurs de four endommagent l'intérieur du four quand vous utilisez le cycle d'auto nettoyage.
- **Nettoyez uniquement les pièces énumérées dans ce manuel du propriétaire.**
- **Avant d'auto nettoyer le four,** enlevez le gril-lèche-frite et tout ustensile de cuisine.
- **Assurez-vous d'essuyer tout renversement excessif avant de commencer d'auto nettoyer le four.**

CONSERVEZ CES INSTRUCTIONS

Features of Your Range

Stainless Steel Range

Design information

(Not all features are on all models. Appearance may vary.)

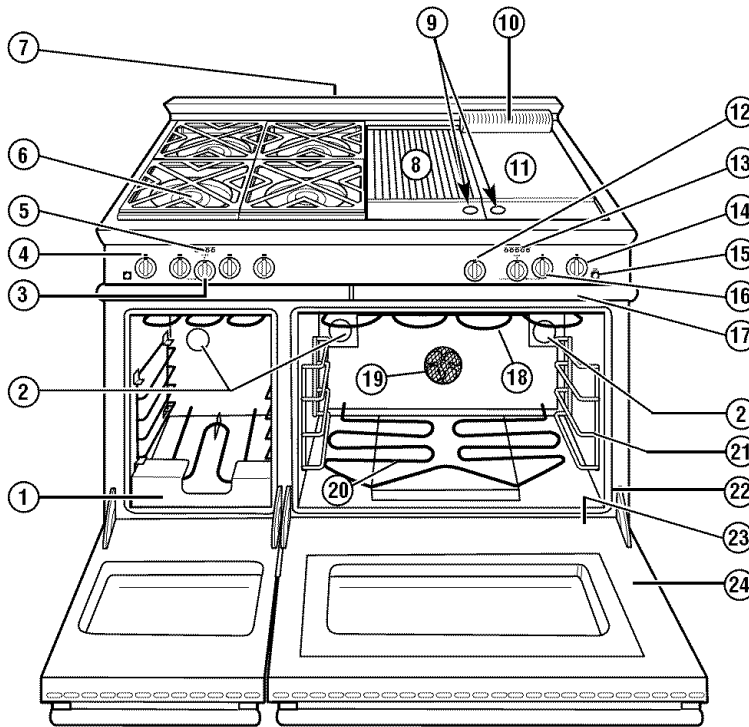
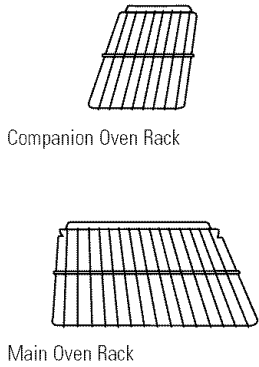

ZDP48N4G
ZDP48L4G

Feature Index	Page
1 Companion Oven Crumb Catch Tray	—
2 Halogen Oven Lights	31
3 Companion Oven Control Knob	22, 23, 26, 27
4 Cooktop Burner Control Knobs	15, 19
5 Companion Oven Controls	22, 23, 26, 27
6 Burner Assemblies	32
7 Backguard	36
8 Grill	18–20, 36
9 Drain Tubes	34
10 Griddle Flue Cover (Vent)	20
11 Griddle	20, 21, 35
12 Grill Control Knob	19, 30
13 Main Oven Controls	22, 26–28
14 Griddle Control Knob	21, 30
15 Oven Light Switch	—
16 Main Oven Control Knob	22, 26–28
17 Pull Out Drip Trays	18, 34
18 Broil Elements	30
19 Convection Fan	25
20 Bake Elements	30
21 Oven Back Guides	28
22 Oven Door Gasket	12, 13
23 Model and Serial Numbers (on the bottom of the oven opening, visible when the oven door is opened)	3, 14
24 Oven Door	26

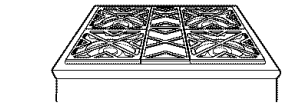

ZDP30N4
ZDP30L4

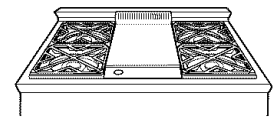

ZDP36N4D
ZDP36L4D

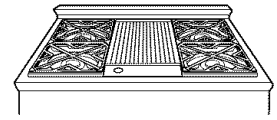

ZDP36N4R
ZDP36L4R

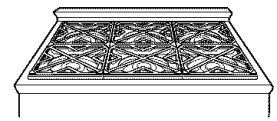

ZDP36N6
ZDP36L6

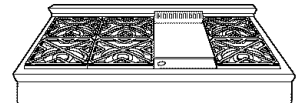

ZDP48N6D
ZDP48L6D

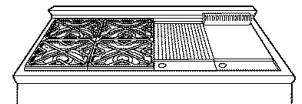

ZDP48N4G
ZDP48L4G

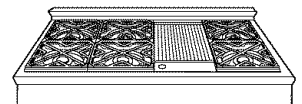

ZDP48N6R
ZDP48L6R

Surface Cooking

Stainless Steel Range

Electronic ignition & automatic reignition

Your surface burners are equipped with electronic ignition which eliminates the need for a standing pilot light.

All igniters will spark and make clicking sounds when only one burner is being turned on. Do not touch any of the burners when igniters are clicking.

The burners on this range will automatically relight if the flame goes out. All burners will spark while any one burner is relighting.

Burners may spark if wind or a draft lifts the flame away from the flame sensor.

In case of a power outage, you can light the surface burners on your cooktop with a match. Hold a lighted match to the burner, then turn the knob to the HIGH position. **Use extreme caution when lighting burners this way.**

To light a burner

Push the control knob down and turn it **counterclockwise** to the LITE position.

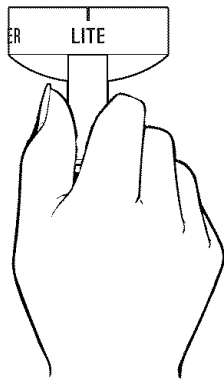

After the burner ignites, turn the knob in either direction to adjust the flame size.

To turn a burner off, turn the knob clockwise, as far as it will go, to the OFF position.

- All of the burners can be used for both general cooking and simmering.
- Do not operate a burner for an extended period of time without cookware on the grate. The finish on the grate may chip without cookware to absorb the heat.
- For your convenience, the indicator lamp in the bezel for each knob verifies the burner is "ON".
- Be sure you turn the control knob to "OFF" when you finish cooking.

How to select flame size

Watch the flame, not the knob, as you increase or reduce heat.

The flame size on a gas burner should match the cookware you are using.

FOR SAFE HANDLING OF COOKWARE, NEVER LET THE FLAME EXTEND UP THE SIDES OF THE COOKWARE. Any flame larger than the bottom of the cookware is wasted and only serves to heat the handle.

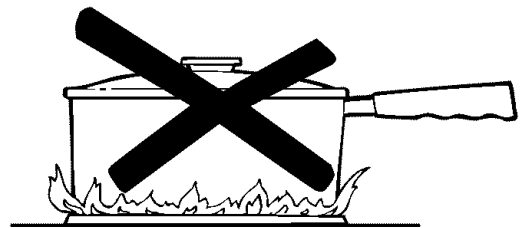

NOTE: Use 10" or larger diameter cookware when using heat settings between HI and X-HI.

Dual-flame burners

All burners on the cooktop have two separate flames: a simmer (lower) flame and a main (upper) flame.

Simmering: Use simmer (SIM) to melt chocolate, hold delicate sauces or for other foods requiring low simmer heat.

Primary Cooking: Settings from LO to X-HI will use both the main and simmer flames. Use LO to HI for all purpose cooking. Use HI or X-HI (highest setting) with 10" or larger diameter cookware.

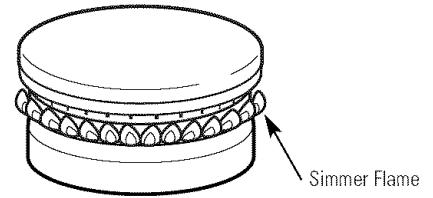

Simmering

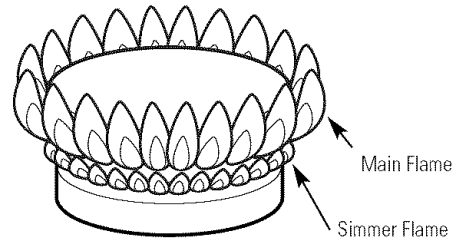

Primary Cooking

Cookware

Aluminum: Medium-weight cookware is recommended because it heats quickly and evenly. Most foods brown evenly in an aluminum skillet. Use saucepans with tight-fitting lids for cooking with minimum amounts of water.

Cast Iron: If heated slowly, most skillets will give satisfactory results.

Enamelware: Under some conditions, the enamel of some cookware may melt. Follow cookware manufacturer's recommendations for cooking methods.

Glass: There are two types of glass cookware—those for oven use only and those for surface cooking (saucepans, coffee and teapots). Glass conductors heat very slowly.

Heatproof Glass-Ceramic: Can be used for either surface or oven cooking. It conducts heat very slowly and cools very slowly. Check cookware manufacturer's directions to be sure it can be used on gas cooktops.

Stainless Steel: This metal alone has poor heating properties, and is usually combined with copper, aluminum or other metals for improved heat distribution. Combination metal skillets generally work satisfactorily if they are used at medium heat as the manufacturer recommends.

Wok cooking

All burner grates are designed to support wok cooking. For easy access and additional clearances to combustibles, we suggest using a front burner for wok cooking.

Lift out one burner grate at the front. Turn it over and replace in the grate frame. The wok side is contoured to support a wok with a round or bowl shaped bottom. This design eliminates the need for a wok ring and will accommodate most woks.

Check to be sure that your wok fits securely and is stable when placed on the wok grate.

CAUTION: Good wok stability is best achieved by using round-bottom woks. Flat-bottom woks are not recommended. Avoid using woks with extremely smooth, untextured, bottom surface finishes as these may allow undesired rocking of the wok in the grate cradle.

ATTENTION : Pour obtenir une bonne stabilité de travail, il vaut mieux utiliser des woks à fond rond. Les woks à fond plat ne sont pas recommandés. Évitez d'utiliser des woks dont le fond a une surface extrêmement lisse, sans texture, car il peuvent occasionner un balancement imprévu du wok dans le trou de la grille.

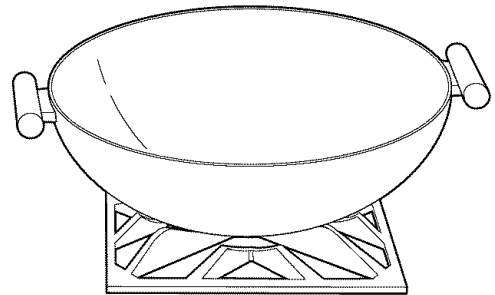

Excessive grill flare-ups and flaming

Occasionally grease drippings ignite. These drippings will create minor puffs of flame for a second or two. This is normal when cooking on a barbecue. You may find it handy to have a spray bottle filled with water to lightly spray the flare-up.

If the flame becomes excessive, remove the food from the grill. Lower the heat setting. Replace the food when the flare-up subsides.

To prevent flare-ups from happening, trim the fat from around the edges of steaks and chops, use hamburger that is lean, remove the fat from poultry, etc.

When turning any kind of meat or poultry, the melting fat will drop onto the grill radiant and may create a flare-up. If this happens, use a long-handled spatula to move the food to another area.

Gourmet Radiant™ Tray

Flare ups are minimized because a Gourmet Radiant™ Tray, below the grille grate, directs grease down to the drip pan before it begins to burn.

Grill grates *(on some models)*

The two-piece cast stainless steel grill grates are reversible. Place the side with the two grooved tabs toward the back of the cooktop.

The grate will change color when subjected to the heat, and as oils cook onto the surface. This is normal and does not affect the cooking performance.

For best results, the grate should be seasoned before the first use. Seasoning will insure a stick-resistant cooking surface. If the grill has not been used for a period of time, it should be reseasoned.

To season the grill grate:

- 1 Clean the grate thoroughly with hot, soapy water to remove any manufacturing oils, etc.
- 2 Rinse with a mixture of 2 cups water and 1/2 cup white vinegar. Dry thoroughly.
- 3 Using a heavy cloth, rub vegetable oil over the entire surface of the rack. Do not use corn oil, as it can get sticky.
- 4 Place grate into the grill housing. Turn the burner on to a medium setting. Turn the burner off when the oil begins to smoke. Allow grates to cool.
- 5 Repeat steps 3 and 4.

The grill is now ready for use.

One side of the grates (side A) is ridged and should be used for foods where you want the fat to run off, such as steak or hamburger patties. The ridges are sloped so the fat runs toward the front of the grill, into a drain hole and down to a drip tray below.

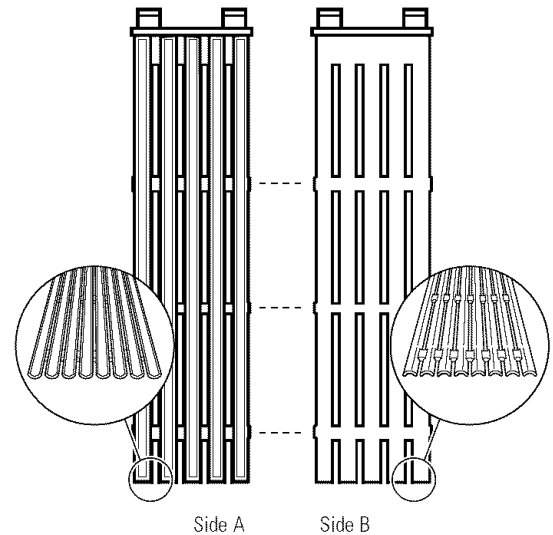

The other side of the grate (side B) is designed for delicate foods that need more support while cooking, such as fish.

Food cooked on this side achieves the same flavor as food cooked on an outdoor grill. The intense heat from the grill radiant caramelizes the fats and juices that are brought to the surface of the food, giving it the barbecued flavor.

This gas grill may cook slightly faster than you are used to.

Using the grill

(on some models)

Remove the cover before lighting the burner. The cover must be removed when using the grill.

Before starting to cook **on** the grill, be sure the drip tray and liners are in place and that you have the grill racks turned to the side you want for cooking.

Preheat the grill for 15 minutes with the control knob set on HI.

NOTE: The longer you preheat the grill, the darker the grill marks will be on your food.

During cooking it may be necessary to adjust the heat setting. The control knob may be set to any position between HI and LO.

For proper searing and browning the grill requires high heat.

With large pieces of meat or poultry you will need to turn the heat to a lower heat setting after the food has been seared. This lower heat setting will allow the food to cook through without burning the outside.

Marinades and barbecue sauce should be added toward the end of cooking time. The heat should be turned to low when sauces are added.

Do not leave the grill unattended while it is on.

When you are finished cooking, allow the grill and the drip trays to cool before cleaning them. They should be cleaned each time they are used.

Replace the grill cover.

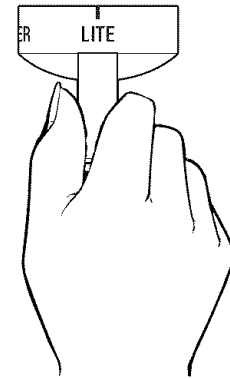

NOTE: The grill will take approximately 45 seconds to ignite. Unlike the surface burners, which use electric igniters, the grill uses a glow bar for ignition. It takes approximately 45 seconds for the glow bar to reach temperature. Gas is only supplied to the grill once the glow bar reaches temperature.

Gourmet Radiant™ Tray

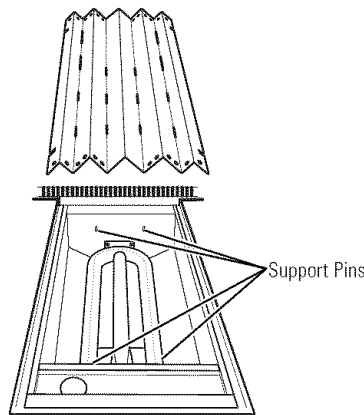

Models equipped with a grill have a Gourmet Radiant™ Tray which distributes the heat from the burners evenly across the grill area.

The tray rests on pins at the front and the back of the grille opening. Be sure the tray is oriented to mate with front and rear support pins.

Grilling hints

- When turning the meat over, always use a spatula as it will not puncture the meat allowing the juices to run out. This will help to keep the meat juicy. Turn the meat only once, as juices are lost when the meat is repeatedly turned. Season or salt the meat after it has been cooked.
- Be sure to trim any excess fat from meat or poultry. To prevent steaks or chops from curling while they are being cooked, slit the fat around the edges at about 2" intervals. To test for doneness, make a small cut in the center of the meat.
- The doneness of meat is affected by the thickness of the cut. It is impossible to cook a thin piece of meat to a rare doneness. A steak should be at least 1" thick to have it turn out rare and juicy. The cooking time is affected by the temperature of the meat when you start to cook it, the size and shape of the cut and the kind of meat you are cooking. The degree of doneness desired also affects the time.
- The U. S. Department of Agriculture says, "Rare beef is popular, but you should know that cooking it to only 140°F means some food poisoning organisms may survive." (Source: Safe Food Book. Your Kitchen Guide. USDA Rev. June 1985.)

Before using the griddle

(on some models)

Remove the cover before turning the griddle on.

The griddle is made from Type 304 stainless steel and highly polished to provide a smooth cooking surface. It is normal for it to darken with use as oils cook onto the surface to provide a stick-resistant base or "seasoning."

The griddle is thermostatically controlled and cycles on and off to maintain the set temperature. A light will glow to indicate the griddle is on.

The griddle assembly should not be removed for cleaning.

Once the unit is in position, the rear center shipping screw can be removed. It is located beneath the griddle flue cover. Remove the flue cover by lifting it straight up. Be careful not to scratch the backguard during removal of the flue cover.

The two outer screws are leveling screws.

Do not remove these two screws. They can be turned to level the griddle or to provide a forward slope to help grease and oils to drain away from the food being cooked. After using the griddle a few times you will be able to judge the slope best for the foods you are cooking and your personal preference.

When replacing the griddle flue cover, ensure that the cover slips to the outside of the front and back metal flanges of the fixed griddle assembly. This will ensure a tight fit of the flue cover.

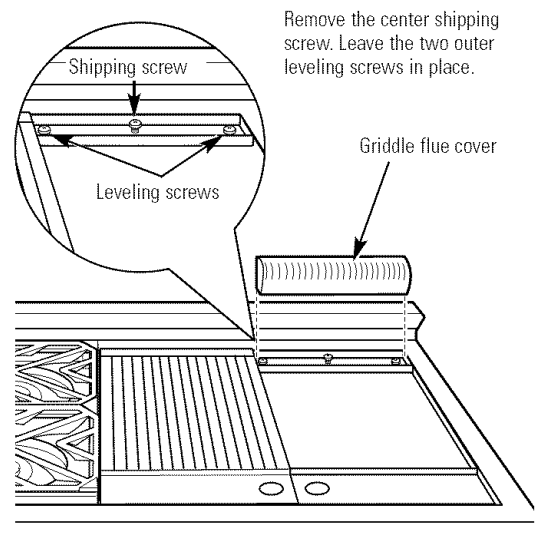

Seasoning the griddle

Before using the griddle for the first time, it must be seasoned.

If the griddle has not been used for a period of time, it should be reseasoned.

To season the griddle:

- 1 Clean the griddle thoroughly with hot, soapy water to remove any protective coating.
- 2 Rinse with a mixture of 1 quart water and 1 cup white vinegar. Dry thoroughly.
- 3 Pour 1 teaspoon vegetable oil into the center of the griddle. Do not use corn oil as it can get sticky. Rub the oil over the entire surface of the griddle using a heavy cloth.

- 4 Turn the control knob to a medium setting (350°F.). Turn the heat off when the oil begins to smoke. Allow the griddle to cool.
- 5 Repeat step 3. Be sure to cover the entire surface with the oil.
- 6 Repeat step 4. Allow the griddle to cool. Wipe the entire surface of the griddle using a heavy cloth. Apply a very thin layer of vegetable oil. The griddle is now ready to use.

Using the griddle

Before starting to cook on the griddle, be sure the drip tray and liners are in place. Select the cooking temperature and preheat for 15 minutes.

NOTE: When the griddle is properly seasoned, it can be used without any additional shortening. However, shortening can be used for flavor.

NOTE: The griddle will take approximately 45 seconds to ignite. Unlike the surface burners, which use electric igniters, the griddle uses a glow bar for ignition. It takes approximately 45 seconds for the glow bar to reach temperature. Gas is only supplied to the griddle once the glow bar reaches temperature.

Oven racks

To avoid possible burns, place the oven racks in the correct position before you turn the oven on.

The correct rack position depends on the kind of food and the browning desired.

The oven racks have stop-locks, so that when placed correctly on the supports, they will stop before coming completely out, and will not tilt. When placing and removing cookware, pull the rack out to the bump on the rack support.

To remove a rack, pull it toward you, tilt the front end up and pull it out.

To replace, place the end of the rack on the support, tilt up the front and push in.

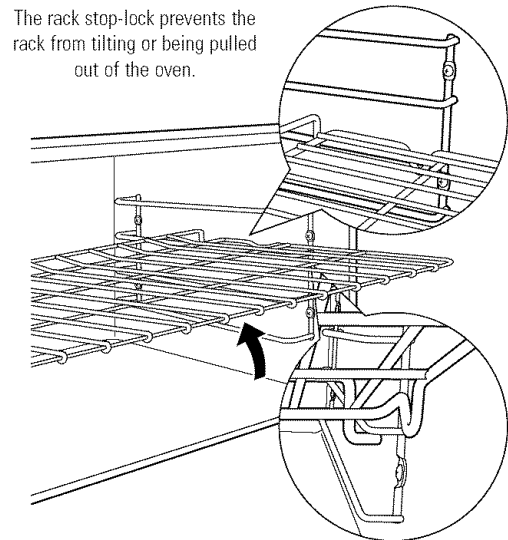

To remove, pull rack out and lift up the front.

How to set the oven controls

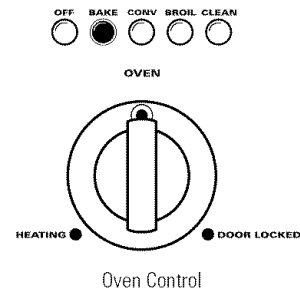
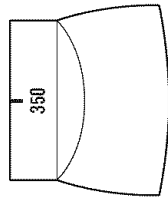

1 Select the desired oven mode by pushing one of the Mode Selector Buttons: BAKE, CONV, BROIL, or CLEAN.

2 Select the desired temperature by turning the Oven Thermostat Knob.

- The Oven light will glow and remain on until the OFF selector button has been pushed or the thermostat dial has been turned to the OFF (O) position.

- The Heating light will glow. The oven is preheated to the set temperature when the Heating light initially cycles off.

3 Turn the oven off by pushing the OFF Mode Selector Button.

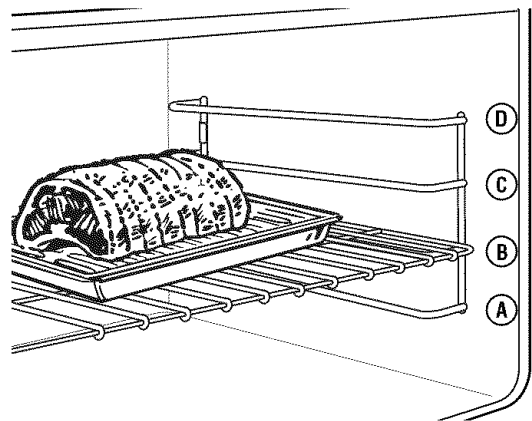

When roasting, use the B or C rack position.

How to set companion oven controls

(48" ranges only)

- 1 Select the desired oven mode by pushing one of the Mode Selector Buttons: BAKE, BROIL or PROOF.
- 2 Select the desired oven temperature by turning the Oven Thermostat Knob.
 - The Oven light will glow and remain on until the OFF selector button has been pushed or the thermostat dial has been turned to the OFF position.
 - The oven is preheated to the set temperature when the HEATING light cycles off.
- 3 Turn the oven off by pushing the OFF Mode Selector Button.

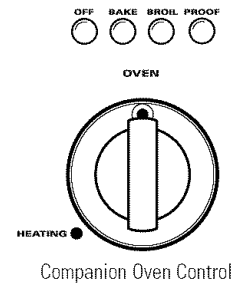

Companion Oven Control

How to set companion oven control for proofing

(48" ranges only)

The proofing feature maintains a warm, non-drafty environment useful for proofing yeast-leavened products.

- 1 Place the dough in a dish in the small oven.
- 2 Push in the PROOF selector button on the left hand side of the control panel above the thermostat dial.
 - The OVEN light and oven interior light turn on.
 - The HEATING light will not turn on.
 - The thermostat dial does not affect the proof temperature.
- 3 Set a minute timer for the minimum proof time. When proofing is finished, push the OFF selector button.
 - To avoid lowering the oven temperature and lengthening proofing time, do not open the oven door unnecessarily.

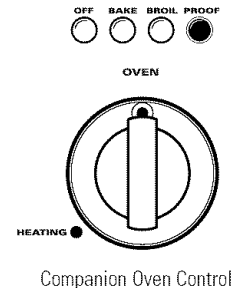

Companion Oven Control

Proofing time may be decreased when you use the large oven at the same time you are proofing.

Check bread products early to avoid over-proofing.

NOTE: Do not use the proofing mode for warming food or keeping food hot. The proofing oven temperature is not hot enough to hold foods at safe temperatures (above 140°F).

Using the Ovens

Stainless Steel Range

Baking pans/sheets

Use the proper baking pan. The type of finish on the pan determines the amount of browning that will occur.

- Dark, rough or dull pans absorb heat resulting in a browner, crisper crust. Use this type for pies.

- Shiny, bright and smooth pans reflect heat, resulting in a lighter, more delicate browning. Cakes and cookies require this type of pan or sheet.
- Glass baking dishes also absorb heat. When baking in glass baking dishes, the temperature may need to be reduced by 25°F.

Pan placement

For even cooking and proper browning, there must be enough room for air circulation in the oven. Baking results will be better if baking pans are centered as much as possible rather than being placed to the front or to the back of the oven.

Pans should not touch each other or the walls of the oven. Allow 1- to 1½" space between pans, between pans and the oven door, and the back or sides of the oven.

If you use two racks, stagger the pans so one is not directly above the other. Check the food on the bottom rack sooner than the minimum time. The food on the lower rack may cook slightly faster than the food on the upper rack.

Preheating

Preheat the oven if the recipe calls for it. To preheat, set the oven at the correct temperature—selecting a higher temperature does not shorten preheat time.

Preheating is necessary for good results when baking cakes, cookies, pastry and breads.

Aluminum foil

Never entirely cover a rack with aluminum foil. This will disturb the heat circulation and result in poor baking. A smaller sheet of foil may be used to catch a spillover by placing it on a lower rack several inches below the food.

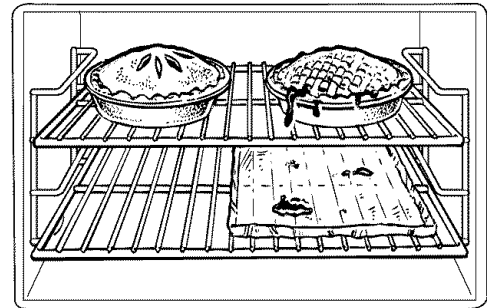

What is convection cooking?

In a convection oven, a fan circulates the heated air evenly, over and around the food. During convection cooking, both the broil element and the bake element are energized along with the convection fan. As a result, foods are evenly browned at lower temperatures and in less time.

- Preheating is not necessary for foods with a bake time over 15 minutes.
- Food is heated faster in a convection oven. When using the convection feature, many types of food can be cooked at lower temperatures than those suggested for regular ovens.
- Good for large quantities of baked foods.
- Good results with cookies, biscuits, brownies, cream puffs, sweet rolls, angel food cake and bread.
- Ideal for baked foods cooked on two or three shelves. Because heated air is circulated evenly throughout the oven, foods can be baked with excellent results on two or three racks at the same time. Multi-rack baking may increase cook times slightly for some foods, but the overall result is time saved. Multi-rack baking provides very good results with cookies, biscuits and other quickbreads.
- Recipe books often give times and temperatures for cooking in traditional thermal ovens. Convection ovens make it possible to reduce the temperature by 25°F.
- Check foods for doneness at the minimum suggested cooking time.
- Some package instructions for frozen casseroles or main dishes have been developed using commercial convection ovens. For best results in this oven, preheat the oven and use the temperature on the package.

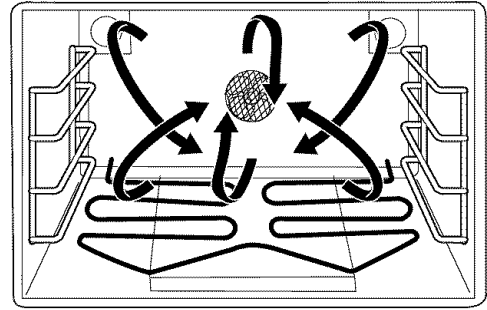

Convection cookware

Before using your convection oven, check to see if your cookware leaves room for air circulation in the oven. If you are baking with several pans, leave space between them. Also, be sure the pans do not touch each other or the walls of the oven. Use the pan size recommended in the recipe.

When baking cookies, you will get the best results if you use a flat cookie sheet instead of a pan with low sides.

For recipes like oven-baked chicken, you should use a pan with low sides. Hot air cannot circulate well around food in a pan with high sides.

Metal and Glass

Any type of cookware will work in your convection oven. However, metal pans heat the fastest and are recommended for convection baking.

- Darkened or matte-finished pans will bake faster than shiny pans.
- Glass or ceramic pans cook more slowly.

Paper and Plastic

Heat-resistant paper and plastic containers that are recommended for use in regular ovens can be used in convection ovens. Plastic cookware that is heat-resistant to temperatures of 400°F can also be used.

How to set the ovens for broiling

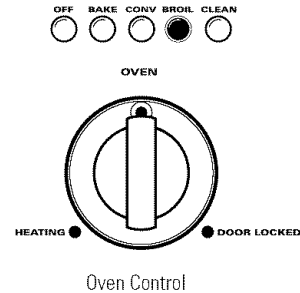
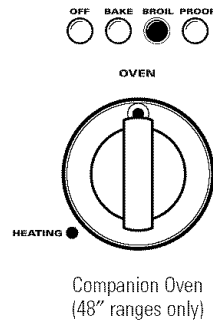

- 1 If the meat has fat or gristle around the edge, cut vertical slashes through both about 2" apart. If desired, the fat may be trimmed, leaving a layer about 1/8" thick.
- 2 Place the meat or fish on the broiler grid in the broiler pan. Always use the grid so that any fat will drip into the broiler pan; otherwise the juices may become hot enough to catch on fire.
- 3 Position a shelf on the recommended shelf position as suggested in the Broiling Guide.
- 4 Close door. Your unit has been designed to broil with the door closed.
- 5 Push in the BROIL selector button on the side of the control panel above the oven you wish to use.

NOTE: A cooling fan will be activated when the BROIL selector button is pushed. This cooling fan cools the oven controls when broiling.

- 6 Turn the control knob below the selector button to BROIL. The broiler does not need to be preheated for most broiling. However, foods that cook quickly, such as thin strips of

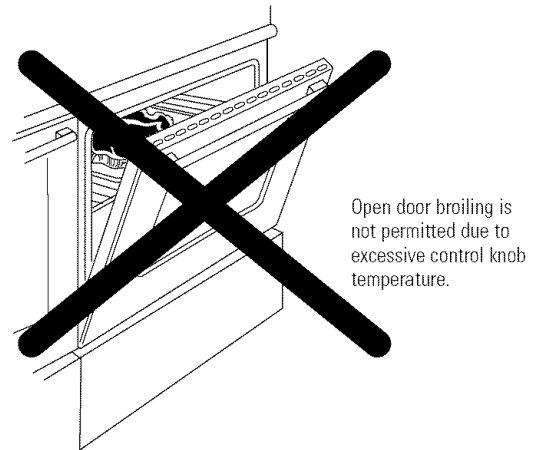

meat or fish may require a short preheating period of 2 to 3 minutes to allow the food surface to brown in the same time the food takes to be cooked throughout.

Turn the food only once during broiling. Time the foods for the first side according to the Broiling Guide.

- 7 When broiling is finished, push in the OFF selector button.

Broiling guide

The size, weight, thickness, starting temperature and your preference of doneness will affect broiling times. This guide is based on meats at refrigerator temperature.

† The U.S. Department of Agriculture says "Rare beef is popular, but you should know that cooking it to only 140°F means some food poisoning organisms may survive." (Source: *Safe Food Book, Your Kitchen Guide*. USDA Rev. June 1985.)

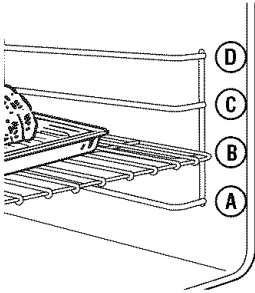

Suggested shelf positions and cooking times are intended as general guidelines only. Experiment with these settings for specific foods and your personal preference.

Food	Quantity/ Thickness	Shelf* Position	1st Side Minutes	2nd Side Minutes	Comments
Bacon	1/2 lb. (about 8 thin slices)	D	3-5	3-5	Arrange in single layer.
Ground Beef Well Done	2 lbs. (8 patties) 1/2 to 3/4" thick	C	10-13	7-10	Space evenly. Up to 8 patties take about the same time.
Beef Steaks Rare† Medium Well Done	1" thick (1 to 1½ lbs.)	C C C	7 8-10 20-25	7 6-9 15	Steaks less than 1" thick cook through before browning. Pan frying is recommended.
Rare† Medium Well Done	1½" thick (2 to 2½ lbs.)	C C B	10 15 25	7-8 14-16 20-25	Slash fat.
Chicken	1 whole (2 to 2½ lbs.), split lengthwise	B	30-35	25-30	Reduce time about 5 to 10 minutes per side for cut-up chicken. Brush each side with melted butter. Broil skin-side-down first.
Bakery Products Bread (Toast) Toaster Pastries English Muffins	2 to 4 slices 1 pkg. (2) 2 (split)	D D D	1½-2 1½-2 4-6	1/2 1/2	Space evenly. Place English muffins cut-side-up and brush with butter, if desired.
Lobster Tails	2-4 (6 to 8 oz. each)	C	14-18	<i>Do not turn over.</i>	Cut through back of shell. Spread open. Brush with melted butter before broiling and after half of broiling time.
Fish	1-lb. fillets 1/4 to 1/2" thick	C	8-10	5-10	Handle and turn very carefully. Brush with lemon butter before and during cooking, if desired. Preheat broiler to increase browning.
Ham Slices (precooked)	1" thick	C	9	8-10	Increase time 5 to 10 minutes per side for 1½" thick or home cured.
Pork Chops Well Done	2 (1/2" thick) 2 (1" thick), about 1 lb.	C C	15 15-20	10-15 15-18	Slash fat.
Lamb Chops Medium Well Done	2 (1" thick), 10 to 12 oz.	C C	8-10 12-15	4-7 8-10	Slash fat.
Medium Well Done	2 (1½" thick), about 1 lb.	C C	10-13 17	10-12 12-14	
Wieners, Sausages, Bratwurst	1-lb. pkg. (10)	C	6-8	1-4	If desired, split in half lengthwise; cut into 5 to 6" pieces.

*See illustration for description of shelf positions.

Self-Cleaning 27" Oven

Stainless Steel Range

Before a clean cycle

NOTE: When the 27" oven is set for self-cleaning, only the surface burners may be used. The 12" oven, the griddle and/or the grill cannot be used.

For the first self-clean cycle, we recommend venting your kitchen with an open window or using a ventilation fan or hood.

Remove the broiler pan, broiler grid, all cookware, probe and any aluminum foil from the oven—they cannot withstand the high cleaning temperatures.

NOTE: Your oven is equipped with gray porcelain-coated oven shelves. They may be left in the oven during the self-clean cycle.

Soil outside the gasket on the front frame of the range and on the door will need to be cleaned by hand. Clean these areas with hot water, soap-filled scouring pads or cleansers such as Soft Scrub®. Rinse well with clean water and dry.

Do not clean the gasket. The fiberglass material of the oven door gasket cannot withstand abrasion. It is essential for the gasket to remain intact. If you notice it becoming worn or frayed, replace it.

Wipe up any heavy spillovers on the oven bottom.

Make sure the oven light bulb cover is in place and the oven light is off.

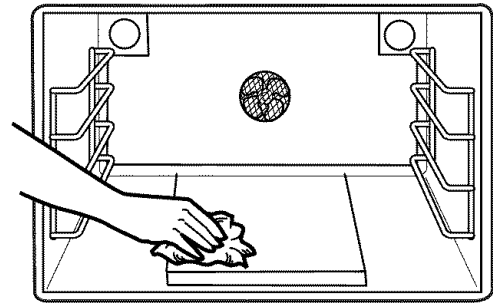

Wipe up heavy soil on the oven bottom.

How to set oven for self-cleaning

The clean cycle takes about 5 hours plus about 30 minutes to cool down.

1 Push in the CLEAN selector button on the right hand side of the control panel above the thermostat dial.

2 Set the thermostat dial to CLEAN.

- Cooling blower turns on.
- The OVEN light and HEATING light turn on.
- The DOOR LOCKED light turns on.
- The blower and the OVEN light will turn off once the cycle has finished.

3 When cleaning has finished, push the OFF selector button.

The door latch will unlock automatically after the oven temperature falls below approx. 550°F.

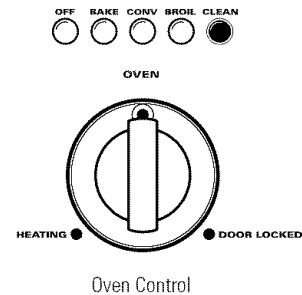

After a clean cycle

If white spots remain, remove them with warm sudsy water and rinse thoroughly with a vinegar and water mixture. These deposits are usually a salt residue that cannot be removed by the clean cycle.

If the oven is not clean after one clean cycle, repeat the cycle.

You may notice some white ash in the oven. Wipe it up with a damp cloth after the oven cools.

If the shelves become hard to slide, apply a small amount of vegetable oil or cooking oil to a paper towel and wipe the edges of the oven shelves and racks with the paper towel.

Companion standard clean

(48" ranges only)

With proper care, the porcelain enamel finish on the inside of the oven—top, bottom, sides, back and inside of the door—will stay new-looking for years.

Let the range cool before cleaning.

We recommend that you wear rubber gloves when cleaning the range.

Soap and water will normally do the job.

Heavy spattering or spillovers may require cleaning with a mild abrasive cleaner. Soapy, wet metal pads may also be used. Do not allow food spills with a high sugar or acid content (such as milk, tomatoes, sauerkraut, fruit juices or pie filling) to remain on the surface. They may cause a dull spot even after cleaning.

Household ammonia may make the cleaning job easier. Place 1/2 cup in a shallow glass or pottery container in a cold oven overnight. The ammonia fumes will help loosen the burned-on grease and food.

If necessary, you may use an oven cleaner.

Follow the package directions.

Cautions about using spray-on oven cleaners:

- Do not spray on the electrical controls and switches because it could cause a short circuit and result in sparking or fire.
- Do not allow a film from the cleaner to build up on the temperature sensor—it could cause the oven to heat improperly. (The sensor is located on the left-hand side of the oven.) Carefully wipe the sensor clean after each oven cleaning, being careful not to move the sensor as a change in its position could affect how the oven bakes.
- Do not spray any oven cleaner on the oven door, handles or any exterior surface of the oven, cabinets or painted surfaces. The cleaner can damage these surfaces.
- Porcelain-coated oven racks may be placed in the 27" oven during self-clean.

Précautions pour utiliser les produits à nettoyer les fours en aérosol :

- Ne pulvérisez jamais sur les contrôles électriques et les commutateurs, car cela peut occasionner un court circuit et provoquer des étincelles ou un incendie.
- Ne permettez jamais à une pellicule de produit à nettoyer de se former sur le thermocontact. Cela peut occasionner une mauvaise température du four (le thermocontact est situé à gauche du four). Essayez soigneusement le thermocontact après chaque nettoyage de four, en prenant soin de ne pas le déplacer car tout changement de position peut changer la température de cuisson du four.
- Ne pulvérisez aucun produit de nettoyage sur la porte du four, les poignées ou toute surface extérieure du four, les surfaces peintes ou la carrosserie de la cuisinière. Le produit de nettoyage peut endommager ces surfaces.
- Vous pouvez placer les clayettes de four émaillées dans le four de 27" pendant l'auto nettoyage.

Care and Cleaning

Stainless Steel Range

Control panel and knobs

Clean up spatters with a damp cloth. Remove heavier soil with warm, soapy water.

Do not use abrasives of any kind on the control panel.

The control knobs may be removed for easier cleaning. To remove a knob, pull it straight off the stem. Wash the knobs in soap and water but do not soak.

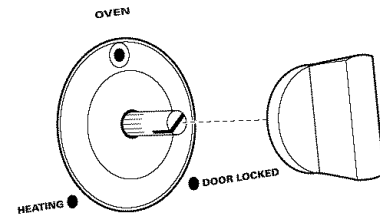

Oven heating elements

Do not clean the bake elements or the broil elements. Any soil will burn off when the elements are heated.

The bake elements can be lifted gently to clean the oven floor. If spillovers, residue or ash accumulate around the bake elements, gently wipe around the element with warm water.

Stainless steel

Do not use a steel-wool pad; it will scratch the surface.

To clean the stainless steel surface, use warm sudsy water or a stainless steel cleaner or polish. Always wipe the surface in the direction of the grain. Follow the cleaner instructions for cleaning the stainless steel surface.

To inquire about purchasing stainless steel appliance cleaner or polish, or to find the location of a dealer nearest you, please call our toll-free number, 800.626.2002 or visit ge.com.

Oven light bulbs

NOTE: The glass cover should be removed only when the oven is completely cool. Wearing latex gloves may offer a better grip.

CAUTION: Before replacing the bulb, disconnect electrical power to the oven at the main fuse or circuit breaker panel.

Be sure to let the light cover and bulb cool completely.

For your safety, do not touch a hot bulb with bare hands or a damp cloth.

ATTENTION : Avant de remettre en place l'ampoule, débranchez l'alimentation électrique du four au niveau du fusible principal ou du tableau de disjoncteurs.

Assurez-vous de laisser refroidir complètement le couvercle de lumière et l'ampoule.

Pour votre sécurité, ne touchez pas une ampoule chaude à mains nues ou avec un linge mouillé.

To remove:

- 1 Turn the glass cover counterclockwise 1/4 turn until the tabs of the glass cover clear the grooves of the socket.
- 2 Using gloves or a dry cloth, remove the bulb by pulling it straight out.

To replace:

- 1 Use a new 130-volt Halogen bulb, not to exceed 35 watts.
- 2 Using gloves or a dry cloth, remove the bulb from its packaging. Do not touch the bulb with bare fingers.
- 3 Push the bulb straight into the receptacle all the way.
- 4 Place the tabs of the glass cover into the grooves of the socket. Turn the glass cover clockwise 1/4 turn.

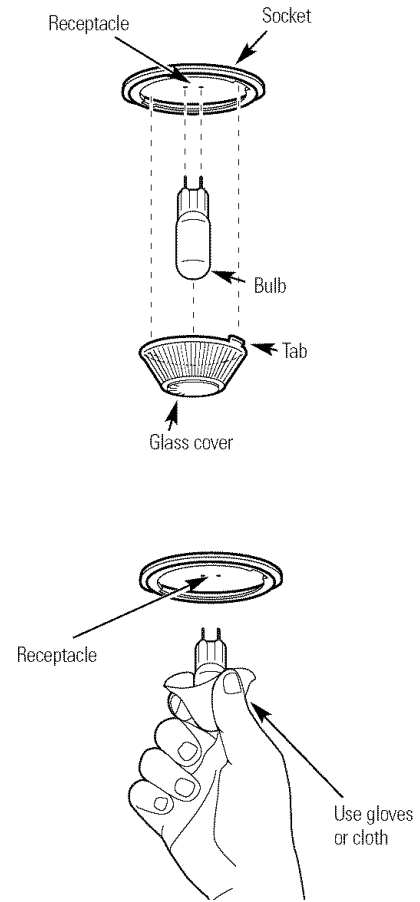

For improved lighting inside the oven, clean the glass cover frequently using a wet cloth. This should be done when the oven is completely cool.

- 5 Reconnect electrical power to the oven.

Broiler pan and grid

After broiling, remove the broiler pan from the oven. Remove the grid from the pan. Carefully pour out the grease from the pan into a proper container. Wash and rinse the broiler pan and grid in hot water with a soap-filled or plastic scouring pad.

If food has burned on, sprinkle the grid with detergent while hot and cover with wet paper towels or a dishcloth. Soaking the pan will remove burned-on foods.

The broiler pan may be cleaned with a commercial oven cleaner. The grid is chrome; do not use an oven cleaner to clean it.

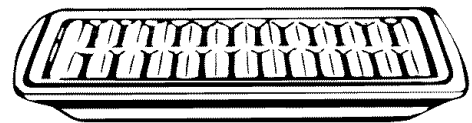

Both the broiler pan and grid can also be cleaned in the dishwasher.

Do not store a soiled broiler pan and grid anywhere in the range.

Sealed burner assemblies

Turn all controls **OFF** before removing the burner parts.

The burner grates, burner caps and burner ring sub-assemblies can be lifted off, making them easy to clean.

CAUTION: DO NOT OPERATE THE BURNER WITHOUT ALL BURNER PARTS IN PLACE.

MISE EN CAUSE : N'UTILISEZ PAS DE BRÛLEUR QUI N'A PAS TOUTES SES PIÈCES EN PLACE.

For proper ignition, make sure the small holes in the burner rings are kept open. A sewing needle or wire twist-tie works well to unclog them.

The slits in the burner heads of your cooktop must be kept clean at all times for an even, unhampered flame.

You should clean the surface burner routinely, especially after bad spillovers, which could clog these openings.

To remove burned-on food, soak the burner heads and rings in a solution of mild liquid detergent and hot water for 20–30 minutes. For more stubborn stains, use a toothbrush.

Clean the burner bases in place on the cooktop.

To remove the burner parts:

- 1 Lift off the burner cap and burner head.
- 2 Remove the burner ring locking nut using a 1/16" socket wrench, crescent wrench or channel-lock pliers.
- 3 Lift off the burner ring. **Do not remove the burner bases.**

Before putting the burner parts back, shake out excess water and then dry them thoroughly by setting them in a warm oven for 30 minutes.

To replace the burner parts:

Make sure all parts for the correct burner are firmly seated.

- 1 Align the locator pins on the burner ring into the labeled hole in the burner base. Seat in place.
- 2 Replace the burner ring locking nut and hand-tighten. Using the wrench or pliers, turn the nut 1/4 turn to secure it in place.
- 3 Align the locator pin in the burner head into the hole in the burner ring. Seat in place.
- 4 Replace the burner caps.

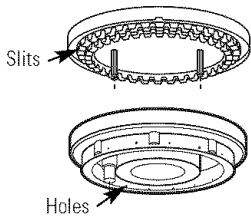
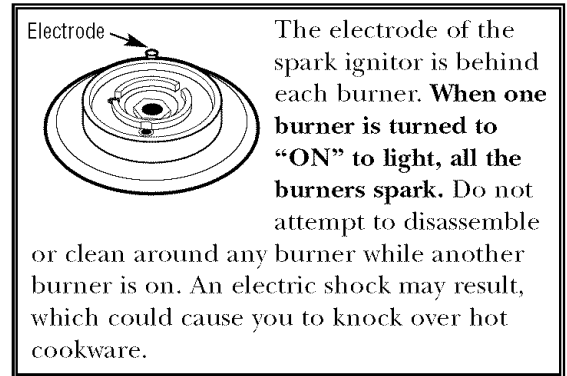

Use a sewing needle, twist-tie and/or toothbrush to unclog the small holes and slits in the burner heads and burner rings.

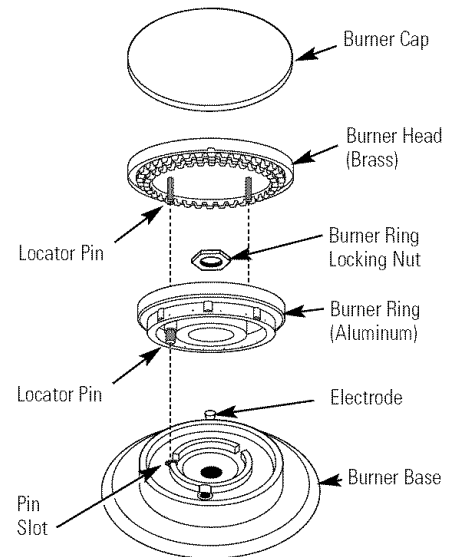

NOTE: Locator pin fits into burner base pin slot.

High Output Burners

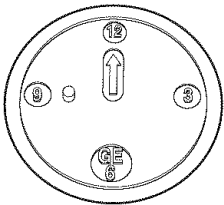

To aid reassembly, each brass Burner Head is marked with a clock face. Replace the Burner Head with the arrow pointing to the rear of the cooktop (12 o'clock position).

Burner caps

Do not use a steel wool pad; it will scratch the surface.

Lift off when cool. Wash burner caps in hot, soapy water and rinse with clean water. You may scour with a plastic scouring pad to remove burned-on food particles.

Dry them in a warm oven or with a cloth—don't reassemble them wet. Replace the burner caps.

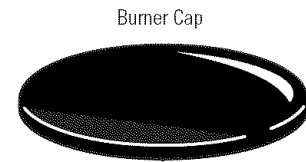

Burner grates

Cast-iron burner grates should be washed regularly and especially after spillovers.

Wash them in hot, soapy water and rinse with clean water. Dry the grates with a cloth—don't put them back on the cooktop wet.

To get rid of burned-on food, place the grates in a covered container or plastic bag. Add 1/4 cup ammonia and let them soak for 30 minutes. Wash, rinse well and dry.

The grates may also be cleaned in a dishwasher.

Although they are durable, the grates will gradually lose their shine, regardless of the best care you can give them. This is due to their continual exposure to high temperatures.

Do not operate a burner for an extended period of time without cookware on the grate. The finish on the grate may chip without cookware to absorb the heat.

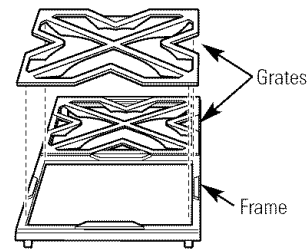

Rubber Grate Feet

For stability, your grates have rubber feet on each leg. If any of these rubber feet should become damaged or lost, replace it with one of the extra rubber feet supplied with your range.

Drip trays, drip tray liners and drain tubes

(on some models)

Located beneath the cooktop you will find a drip tray and liner(s). The drip trays and liners are made of stainless steel. The drip trays are on rollers so they are easy to remove and replace.

To remove the drip tray liner, pull the drip tray forward. If something has spilled into the tray, it should be cleaned up as soon as possible to prevent “baked on” food soil.

Grease from the griddle or the grill drains through the drain tubes into the tray and into the liner below.

Do not allow the grease to accumulate in the drip tray or liner as it can be a fire hazard. Clean the drip tray and liner as soon as they are cool. Clean with hot soapy water.

To remove the drip tray, pull it forward to stop, push in on the release tabs located on each side of the tray and continue to pull forward.

To clean the drain tube use a soapy bottle brush. A mild abrasive cleaner such as Bon-Ami® or Soft Scrub® can be used. For stubborn stains, use a soap-filled scouring pad or a harsh abrasive cleaner such as Comet® or Ajax®, rubbing lightly. Rinse all parts thoroughly.

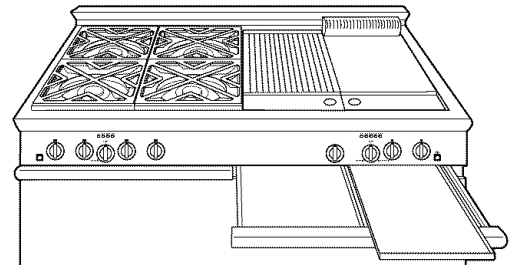
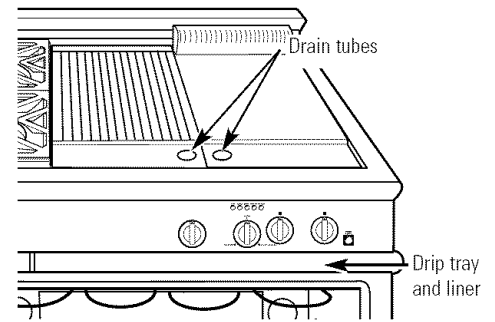

Griddle

(on some models)

Thoroughly clean the griddle of grease and food particles, using a square-edged spatula, while it is still hot.

Wipe the griddle with a dry, heavy, coarse cloth to remove any remaining residue and food particles.

If desired, wash with hot soapy water, rinse and dry.

Once the griddle has cooled, rub the surface lightly with vegetable oil. Do not use corn oil or cooking sprays as they get sticky.

If the griddle is cleaned with anything other than a dry, heavy, coarse cloth, it will need to be reseasoned.

Never flood the hot griddle with cold water. This could cause the griddle to crack or warp.

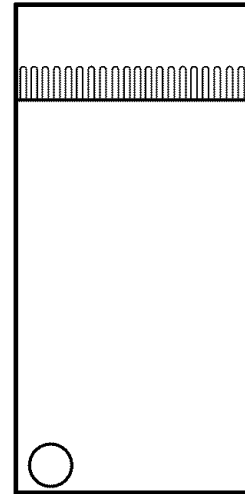

Grill (on some models)

Clean the grill immediately after cooking. Turn off the burner. To protect your hand from steam and heat, wear a barbecue mitt. Scrub the grill with a brass bristle barbecue brush, frequently rinsing in a bowl of water.

The steam created softens the food particles and assists the cleaning process. The food particles will drop into the liner and drip tray. Be sure to clean the drain tube, drip tray and liner after they have cooled.

Clean the Gourmet Radiant™ Tray with hot soapy water. Rinse and dry.

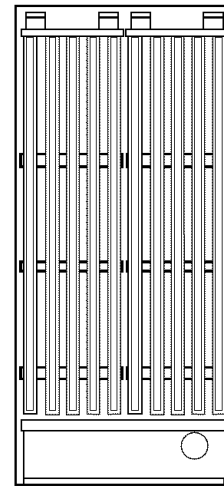

Backguards and shelf

The backguards and shelf are made of stainless steel.

Do not use a steel-wool pad; it will scratch the surface.

Clean with hot soapy water. Rinse and dry.

If the panel and shelf have food soil remaining, try a general kitchen cleaner, such as Fantastik®, Simple Green® or Formula 409®.

For hard to clean soil use a standard stainless steel cleaner such as Bon-Ami®, Cameo® or Bar Keepers Friend®. Apply cleaner with a damp sponge, rinse thoroughly and dry. Always scrub lightly in the direction of the grain.

After cleaning, use a stainless steel polish such as Stainless Steel Magic®.

Lift-Off Oven Door

The oven door is removable for easier access to the light bulb and cleaning.

Do not lift the door by the handle.

To remove the door:

- 1 Fully open the door.
- 2 Each hinge has a hinge lock. Close the hinge latches down against the door frame.
- 3 Firmly grasp the door **at the top sides**.
- 4 Close the door to the near-vertical position.
- 5 Lift the door up and pull straight out.

To replace the door:

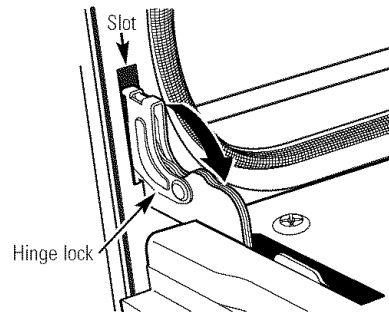

- 1 Firmly grasp the door **at the top sides**. **This is critical.**
- 2 Approach the range with the door angled in a vertical position.
- 3 Guide the hinges into the slots.
- 4 Push the door in firmly while opening.
- 5 Once in position, open the door completely. Push the hinge locks back in and toward the front frame.

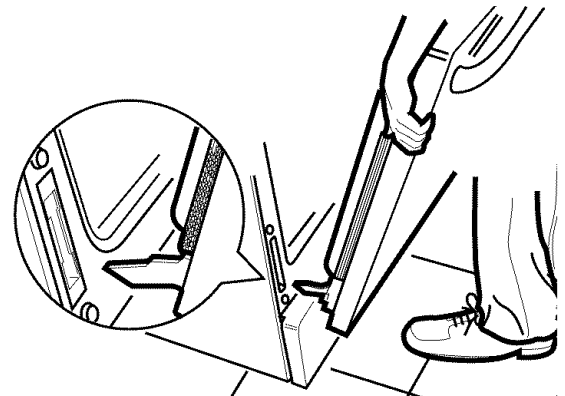

Pull the hinge locks down to unlock.

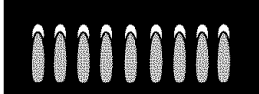

*Questions?
Before you
call for
service...*

PROBLEM	POSSIBLE CAUSE
BURNERS DO NOT LIGHT OR SPARK RANDOMLY	<ul style="list-style-type: none"> • Electrical plug is not plugged into a live power outlet. • Gas not turned on. • Burner parts not replaced correctly. • Holes in the simmer rings or slits in the burner rings are clogged. • Clogged orifice, or wet burners or electrodes.
BURNERS HAVE YELLOW OR YELLOW-TIPPED FLAMES	<ul style="list-style-type: none"> • Burner parts not replaced correctly. <div style="display: flex; justify-content: space-around; align-items: flex-start;"> <div style="text-align: center;">  <p>A. Yellow flames: <i>Call for service.</i></p> </div> <div style="text-align: center;">  <p>B. Yellow tips on outer cones: <i>Normal for LP gas.</i></p> </div> <div style="text-align: center;">  <p>C. Soft blue flames: <i>Normal for natural gas.</i></p> </div> </div> <ul style="list-style-type: none"> • If burner flames look like (A), call for service. Normal burner flames should look like (B) or (C), depending on the type of gas.
BURNER FLAMES VERY LARGE OR YELLOW	<ul style="list-style-type: none"> • If cooktop is connected to LP gas, contact the person who installed your range or made the conversion.
BURNER CONTROL KNOB WILL NOT TURN	<ul style="list-style-type: none"> • When the knob is at the OFF position, it must be pushed in before it can be turned, and it can only be turned in a counterclockwise direction. Similarly, when the knob is in the LOW or X-HI positions, it must also be pushed in to change flame settings.
OVEN LIGHT DOES NOT WORK	<ul style="list-style-type: none"> • The light bulb is loose or defective. Tighten or replace the bulb. • The switch operating light is broken. Call for service.
FOOD DOES NOT BAKE OR ROAST PROPERLY	<ul style="list-style-type: none"> • The oven controls are improperly set. See the “How to set your oven for baking or roasting” section. • Incorrect cookware or cookware of improper size being used. See the “How to set your oven for baking or roasting” section. • Use a foil tent to slow down browning during roasting.
FOOD DOES NOT BROIL PROPERLY	<ul style="list-style-type: none"> • The oven control is not set at BROIL. Push in the BROIL selector button for the oven you want to use. • Improper shelf position being used. See the Broiling Guide. • Cookware is not suited for broiling. Use the broiling pan and grid that came with your range. • Aluminum foil used on the broiling pan and grid has not been fitted properly and slit as recommended. • In some areas the power (voltage) may be low. Preheat the broil element for 10 minutes. Broil for the longest period of time recommended in the Broiling Guide.

The Problem Solver

Stainless Steel Range

*Questions?
Before you
call for
service...*

PROBLEM	POSSIBLE CAUSE
OVEN WILL NOT WORK	<ul style="list-style-type: none">• Plug on the range is not completely inserted in the electrical outlet.• A fuse in your home may be blown or the circuit breaker tripped.• The oven controls are not properly set.• The oven controls are set for cleaning. If necessary, allow the oven to cool then open the door.
OVEN WILL NOT SELF-CLEAN	<ul style="list-style-type: none">• The controls are not properly set.
48" MODELS: UNABLE TO USE THE COMPANION OVEN, GRIDDLE AND/OR GRILL WHEN SELF-CLEANING	<ul style="list-style-type: none">• When the oven is set for cleaning, only the surface burners may be used. The companion oven, the griddle and/or the grill cannot be used.
"CRACKING" OR "POPPING" SOUND DURING CLEANING	<ul style="list-style-type: none">• This is normal. This is the sound of the metal heating and cooling during both the cooking and cleaning functions.
EXCESSIVE SMOKING OCCURS DURING CLEANING	<ul style="list-style-type: none">• Excessive soil. Press the OFF selector button. Open the windows to rid the room of smoke. Wait until the DOOR LOCKED light goes off. Wipe up excess soil and reset the clean cycle.
STRONG ODOR FROM SELF-CLEAN CYCLE	<ul style="list-style-type: none">• An odor from the insulation around the inside of the oven is normal for the first few times the oven is used. This is temporary.
OVEN NOT CLEAN AFTER A CLEAN CYCLE	<ul style="list-style-type: none">• The oven was heavily soiled. Clean up heavy spillovers before starting the clean cycle. Heavily soiled ovens may need to self-clean again.• The oven controls are not properly set. See the Self-Cleaning section.

With the purchase of your new Monogram appliance, receive the assurance that if you ever need information or assistance from GE, we will be there. All you have to do is call—toll-free!

GE Answer Center®

**In the USA:
800.626.2000**

Whatever your question about any Monogram major appliance, GE Answer Center® information service is available to help. Your call—and your question—will be answered promptly and courteously. And you can call any time. GE Answer Center® service is open 24 hours a day, 7 days a week.

OR

Visit our Website at: ge.com

In Canada, call 1.888.880.3030.

In-Home Repair Service

**In the USA:
800.444.1845**

**In Canada:
1.888.880.3030**

A GE consumer service professional will provide expert repair service, scheduled at a time that's convenient for you. Many GE Consumer Service company-operated locations offer you service today or tomorrow, or at your convenience (7:00 a.m. to 7:00 p.m. weekdays, 9:00 a.m. to 2:00 p.m. Saturdays). Our factory-trained technicians know your appliance inside and out—so most repairs can be handled in just one visit.

For Customers With Special Needs...

**In the USA:
800.626.2000**

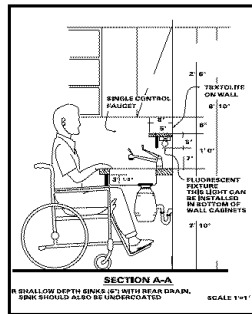

GE offers a brochure to assist in planning a barrier-free kitchen for persons with limited mobility.

Consumers with impaired hearing or speech who have access to a TDD or a conventional teletypewriter may call 800.TDD.GEAC (800.833.4322) to request information or service.

Service Contracts

**In the USA:
800.626.2224**

**In Canada:
1.888.880.3030**

You can have the secure feeling that GE Consumer Service will still be there after your warranty expires. Purchase a GE contract while your warranty is still in effect and you'll receive a substantial discount. With a multiple-year contract, you're assured of future service at today's prices.

Parts and Accessories

**In the USA:
800.626.2002**

**In Canada:
1.888.880.3030**

Individuals qualified to service their own appliances can have parts or accessories sent directly to their home. The GE parts system provides access to over 47,000 parts...and all GE Genuine Renewal Parts are fully warranted. VISA, MasterCard and Discover cards are accepted.

User maintenance instructions contained in this manual cover procedures intended to be performed by any user. Other servicing generally should be referred to qualified service personnel. Caution must be exercised, since improper servicing may cause unsafe operation.

YOUR MONOGRAM RANGE WARRANTY

Staple sales slip or cancelled check here. Proof of original purchase date is needed to obtain service under warranty. Please have serial number and model number available when calling for service.

WHAT IS COVERED

LIMITED ONE-YEAR WARRANTY

For one year from date of original purchase, we will provide, free of charge, parts and service labor in your home to repair or replace **any part of the range** that fails because of a manufacturing defect.

LIMITED FIVE-YEAR WARRANTY

For five years from the date of original purchase, we will provide, free of charge, replacement **gas surface burners** if they fail in normal household use. (The grill, griddle and oven burners are not included.) You pay for the service trip to your home and all service labor charges.

LIMITED LIFETIME WARRANTY

For the lifetime of the gray porcelain enamel oven racks, we will provide, free of charge, replacement **racks** if they fail in

normal household use. You pay for the service trip to your home and all service labor charges.

This warranty is extended to the original purchaser and any succeeding owner for products purchased for ordinary home use in the 48 mainland states, Hawaii and Washington, D.C. In Alaska the warranty is the same except that it is LIMITED because you must pay to ship the product to the service shop or for the service technician's travel costs to your home.

All warranty service will be provided by our Factory Service Centers or by our authorized Customer Care® servicers during normal working hours.

Should your appliance need service, during warranty period or beyond, in the U.S.A. call 800.444.1845. In Canada: 888.880.3030.

WHAT IS NOT COVERED

- Service trips to your home to teach you how to use the product.
- Discoloration of the griddle plate or oven racks.
- Chipping of porcelain enamel grates or oven racks.
- Replacement of house fuses or resetting of circuit breakers.
- Incidental or consequential damage caused by possible defects with this appliance.
- Damage after delivery.
- Damage to the product caused by accident, fire, floods or acts of God.
- Failure of the product if it is used for other than its intended purpose or used commercially.
- Improper installation, delivery or maintenance.

If you have an installation problem, contact your dealer or installer. You are responsible for providing adequate electrical, gas, exhausting and other connecting facilities as described in the Installation Instructions provided with the product.

- Product not accessible to provide required service.

EXCLUSION OF IMPLIED WARRANTIES—Your sole and exclusive remedy is product repair as provided in this Limited Warranty. Any implied warranties, including the implied warranties of merchantability or fitness for a particular purpose, are limited to one year or the shortest period allowed by law.

Some states do not allow the exclusion or limitation of incidental or consequential damages, so the above limitation or exclusion may not apply to you. This warranty gives you specific legal rights, and you may also have other rights which vary from state to state.

To know what your legal rights are in your state, consult your local or state consumer affairs office or your state's Attorney General.

**Consumer Product
Ownership Registration**
Important Mail Today

GE Appliances



Place
1st Class
Letter
Stamp
Here

General Electric Company
Warranty Registration Department
P.O. Box 32150
Louisville, KY 40232-2150

Consumer Product Ownership Registration

Dear Customer:

Thank you for purchasing our product and thank you for placing your confidence in us. We are proud to have you as a customer!

Follow these three steps to protect your new appliance investment:



1

Complete and mail your Consumer Product Ownership Registration today. Have the peace of mind of knowing we can contact you in the unlikely event of a safety modification.

2

After completing this registration, write your model and serial numbers in this manual. You will need this information should you require service. The service number in the USA: 800.444.1845. In Canada: 1.888.880.3030.

3

Read your Owner's Manual carefully. It will help you operate your new appliance properly.

Important: To ensure that your product is registered, mail the separate product registration card. If the separate product registration card is missing, fold and mail the form below. No envelope is needed.

FOLD HERE

Consumer Product Ownership Registration



Important
Mail
Today!

Product
Range

Model

Serial

Mr. Ms. Mrs. Miss

First
Name

Last
Name

Street
Address

Apt. #

City

State

Zip
Code

Date Placed

In Use
Month

Day

Year

Phone
Number



GE Consumer & Industrial
Appliances
General Electric Company
Louisville, KY 40225
ge.com

* Please provide your e-mail address to receive, via e-mail, discounts, special offers and other important communications from GE Appliances (GEA).

Check here if you do not want to receive communications from GEA's carefully selected partners.

FAILURE TO COMPLETE AND RETURN THIS CARD DOES NOT DIMINISH YOUR WARRANTY RIGHTS.

For more information about GEA's privacy and data usage policy, go to ge.com and click on "Privacy Policy" or call 800.626.2224



TAPE CLOSED



GE Consumer & Industrial
Appliances
General Electric Company
Louisville, KY 40225
ge.com

49-80380

17685 Rev. B 12-05 JR

Printed in the United States