

OPERATOR'S MANUAL

SELF-PROPELLED ROTARY LAWN MOWER

- **Assembly**
 - **Operation**
 - **Maintenance**
 - **Service and Adjustments**
 - **Storage**
 - **Troubleshooting**

⚠WARNING: This lawn mower is equipped with an internal combustion engine and should not be used on or near any unimproved forest-covered, brush-covered or grass-covered land unless the engine's exhaust system is equipped with a spark arrester meeting applicable local or state laws (if any). If a spark arrester is used, it should be maintained in effective working order by the operator.

In the state of California the above is required by law (Section 4442 of the California Public Resources Code). Other states may have similar laws. Federal laws apply on federal lands. A spark arrester for the muffler is available through your nearest authorized service center.

TABLE OF CONTENTS

Safety Rules	2-3	Maintenance	16-18	Storage	22-23
Assembly	4-7	Service and		Troubleshooting	23-24
Operation	8-15	Adjustments.....	18-21		

SAFETY RULES

IMPORTANT: This cutting machine is capable of amputating hands and feet and throwing objects. Failure to observe the following safety instructions could result in serious injury or death.

⚠ Look for this symbol to point out important safety precautions. It means **CAUTION!!! BECOME ALERT!!! YOUR SAFETY IS INVOLVED.**

⚠ WARNING: In order to prevent accidental starting when setting up, transporting, adjusting or making repairs, always disconnect spark plug wire and place wire where it cannot come in contact with plug.

⚠ WARNING: Engine exhaust, some of its constituents, and certain vehicle components contain or emit chemicals known to the State of California to cause cancer and birth defects or other reproductive harm.

⚠ WARNING: Battery posts, terminals and related accessories contain lead and lead compounds, chemicals known to the State of California to cause cancer and birth defects or other reproductive harm. **Wash hands after handling.**

⚠ CAUTION: Muffler and other engine parts become extremely hot during operation and remain hot after engine has stopped. To avoid severe burns on contact, stay away from these areas.

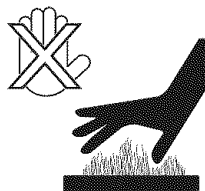

I. GENERAL OPERATION

- Read, understand, and follow all instructions on the machine and in the manual(s) before starting. Be thoroughly familiar with the controls and the proper use of the machine before starting.
- Do not put hands or feet near or under rotating parts. Keep clear of the discharge opening at all times.
- Only allow responsible individuals, who are familiar with the instructions, to operate the machine.
- Clear the area of objects such as rocks, toys, wire, bones, sticks, etc., which could be picked up and thrown by blade.
- Be sure the area is clear of other people before mowing. Stop machine if anyone enters the area.
- Do not operate the mower when barefoot or wearing open sandals. Always wear substantial foot wear.

- Do not pull mower backwards unless absolutely necessary. Always look down and behind before and while moving backwards.
- Never direct discharged material toward anyone. Avoid discharging material against a wall or obstruction. Material may ricochet back toward the operator. Stop the blade when crossing gravel surfaces.
- Do not operate the mower without proper guards, plates, grass catcher or other safety protective devices in place.
- See manufacturer's instructions for proper operation and installation of accessories. Only use accessories approved by the manufacturer.
- Stop the blade(s) when crossing gravel drives, walks, or roads.
- Stop the engine (motor) whenever you leave the equipment, before cleaning the mower or unclogging the chute.
- Shut the engine (motor) off and wait until the blade comes to complete stop before removing grass catcher.
- Mow only in daylight / good artificial light.
- Do not operate the machine while under the influence of alcohol or drugs.
- Never operate machine in wet grass. Always be sure of your footing: keep a firm hold on the handle; walk, never run.
- Disengage the self-propelled mechanism or drive clutch on mowers so equipped before starting the engine.
- If the equipment should start to vibrate abnormally, stop the engine (motor) and check immediately for the cause. Vibration is generally a warning of trouble.
- Always wear safety goggles or safety glasses with side shields when operating mower.

II. SLOPE OPERATION

Slopes are a major factor related to slip & fall accidents which can result in severe injury. All slopes require extra caution. If you feel uneasy on a slope, do not mow it.

DO:

- Mow across the face of slopes: never up and down. Exercise extreme caution when changing direction on slopes.

- Remove obstacles (rocks, tree limbs, etc.)
- Watch for holes, ruts, or bumps. Tall grass can hide obstacles.

DO NOT:

- Do not trim near drop-offs, ditches or embankments. The operator could lose footing or balance.
- Do not trim excessively steep slopes.
- Do not mow on wet grass. Reduced footing could cause slipping.

III. CHILDREN

Tragic accidents can occur if the operator is not alert to the presence of children. Children are often attracted to the machine and the mowing activity. *Never* assume that children will remain where you last saw them.

- Keep children out of the trimming area and under the watchful care of another responsible adult.
- Be alert and turn machine off if children enter the area.
- Before and while walking backwards, look behind and *down* for small children.
- Never allow children to operate the mower.
- Use extra care when approaching blind corners, shrubs, trees, or other objects that may obscure vision.

IV. SAFE HANDLING OF GASOLINE

Use extreme care in handling gasoline. Gasoline is extremely flammable and the vapors are explosive.

- Extinguish all cigarettes, cigars, pipes and other sources of ignition.
- Use only an approved container.
- Never remove gas cap or add fuel with the engine running. Allow engine to cool before refueling.
- Never refuel the machine indoors.
- Never store the machine or fuel container where there is an open flame, spark or pilot light such as a water heater or on other appliances.
- Never fill containers inside a vehicle, on a truck or trailer bed with a plastic liner. Always place containers on the ground

- away from your vehicle before filling.
- Remove gas-powered equipment from the truck or trailer and refuel it on the ground. If this is not possible, then refuel such equipment with a portable container, rather than from a gasoline dispenser nozzle.
- Keep the nozzle in contact with the rim of the fuel tank or container opening at all times until fueling is complete. Do not use a nozzle lock-open device.
- If fuel is spilled on clothing, change clothing immediately.
- Never overfill fuel tank. Replace gas cap and tighten securely.

V. GENERAL SERVICE

- Never run machine inside a closed area.
- Never make adjustments or repairs with the engine (motor) running. Disconnect the spark plug wire, and keep the wire away from the plug to prevent accidental starting.
- Keep nuts and bolts, especially blade attachment bolts, tight and keep equipment in good condition.
- Never tamper with safety devices. Check their proper operation regularly.
- Keep machine free of grass, leaves, or other debris build-up. Clean oil or fuel spillage. Allow machine to cool before storing.
- Stop and inspect the equipment if you strike an object. Repair, if necessary, before restarting.
- Never attempt to make wheel height adjustments while the engine is running.
- Grass catcher components are subject to wear, damage, and deterioration, which could expose moving parts or allow objects to be thrown. Frequently check components and replace with manufacturer's recommended parts, when necessary.
- Mower blades are sharp and can cut. Wrap the blade(s) or wear gloves, and use extra caution when servicing them.
- Do not change the engine governor setting or overspeed the engine.
- Maintain or replace safety and instruction labels, as necessary.

CONGRATULATIONS on your purchase of a new Lawn Mower. It has been designed, engineered and manufactured to give you the best possible dependability and performance. Should you experience any problems you cannot easily remedy, please contact your nearest authorized service center. They have competent, well trained technicians and the proper tools to service or repair this unit.

- Read the SAFETY RULES and this Operator's Manual in its entirety before you attempt to assemble or operate your new lawn mower to insure proper operation and to prevent injury to yourself and others. Save this manual for future reference.
- Your new lawn mower has been assembled at the factory with the exception of those parts left unassembled for shipping purposes. To ensure safe and proper operation of your lawn mower, all parts and hardware you assemble must be tightened securely. Use the correct tools as necessary to ensure proper tightness.
- All parts such as nuts, washers, bolts, etc., necessary to complete the assembly have been placed in the parts bag.

TO REMOVE MOWER FROM CARTON

- Remove all loose parts from carton.
- Remove lawn mower housing with care. Avoid touching blade under housing. Always wear gloves or other protection when working under or lifting mower.

THINGS TO KNOW BEFORE YOU ASSEMBLE OR OPERATE YOUR LAWN MOWER

Do I have a side or rear discharge lawn mower?

Look for the grass discharge opening on your mower. If the opening is on the right side of the mower housing, it is a side discharge mower. If the opening is at the back of the mower housing, it is a rear discharge mower. Only rear discharge lawn mowers have a grass catcher included with the mower. Approved grass catchers for side discharge mowers may be purchased from your nearest authorized dealer.

Do I have a mulching lawn mower?

Look for the grass discharge opening on your mower. Raise the discharge guard (rear door on rear discharge mowers). If the opening is closed off by a plate, then your lawn mower is mulcher ready. To convert to a discharging mower, see the Operation section of this manual.

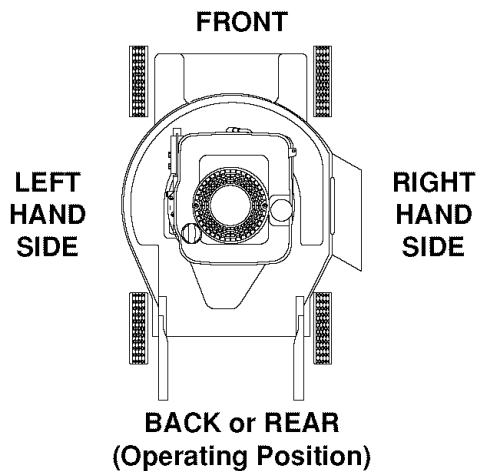

What is the right and left side of the lawn mower?

When right hand (RH) or left hand (LH) is mentioned in this manual, it means when you are in the operating position (standing behind the handle).

What kind of engine is on my lawn mower?

When learning how to operate your new lawn mower, you will need to know what kind of engine powers the mower. A decal on the engine will indicate the manufacturer and type or brand name of the engine.

BRIGGS & STRATTON ENGINES

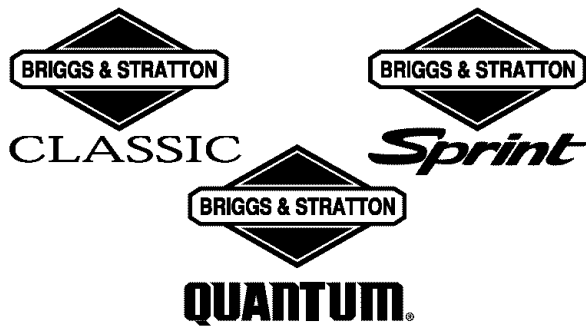

TECUMSEH ENGINES



HONDA ENGINES



ASSEMBLY

⚠CAUTION: Do not operate this lawn mower without the discharge guard or an entire approved grass catcher in place. These guards are for your protection and are required by the American National Standards Institute and Consumer Products Safety Commission.

⚠CAUTION: Disconnect spark plug wire from spark plug and place wire where it cannot come in contact with plug.

HOW TO SET UP YOUR LAWN MOWER

UNFOLD HANDLE

IMPORTANT: Unfold handle carefully so as not to pinch or damage control cables.

2 POSITION / "ADJUSTABLE" HANDLES

- Raise handles until lower handle section locks into place in operating position.

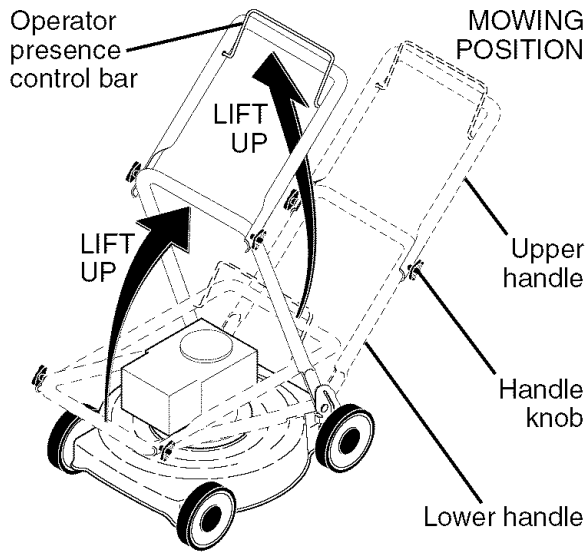

ALL HANDLES

- Raise upper handle section into place on lower handle, remove protective padding and tighten both handle knobs.
- Remove handle padding holding operator presence control bar to upper handle.
- Your lawn mower handle can be adjusted for your mowing comfort. Refer to "ADJUST HANDLE" in the Service and Adjustments section of this manual.

NOTE: For shipping purposes, the rear wheels on your lawn mower may not be adjusted to the same position as the front wheels. Before operating mower adjust all wheels to the same cutting height.

3 POSITION "EZ" HANDLES

- Raise lower handle section to operating position and align hole in handle with one of three height positioning holes.
- Insert handle bolt through handle and bracket and secure with knob.
- Repeat for opposite side of handle.

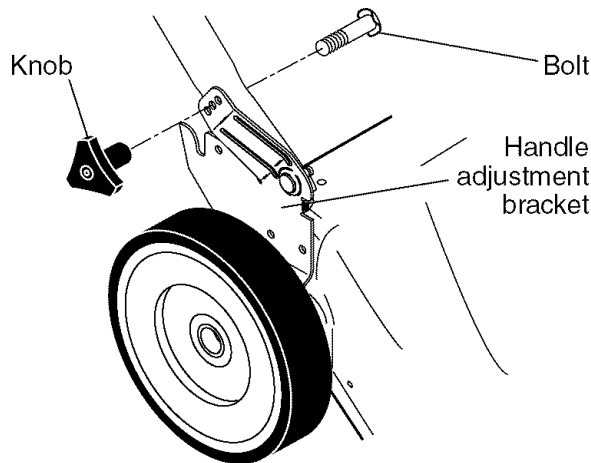

INSTALL REAR WHEELS (HIGH WHEEL MOWERS ONLY)

Some high wheel models require washers which will be provided in a parts bag. If provided, install washers on the axle first as shown.

- Install one (1) rear wheel on the axle of rear wheel adjuster.
- Install 3/8-16 locknut and tighten securely.
- Repeat procedure for other rear wheel.

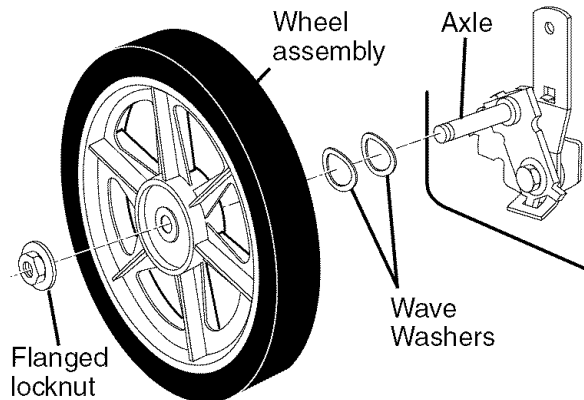

3 POSITION "QUICK" HANDLES

- Raise lower handle section to operating position and squeeze the bottom ends of lower handle towards each other until the pin in handle can be inserted into one of the three height adjustment holes.

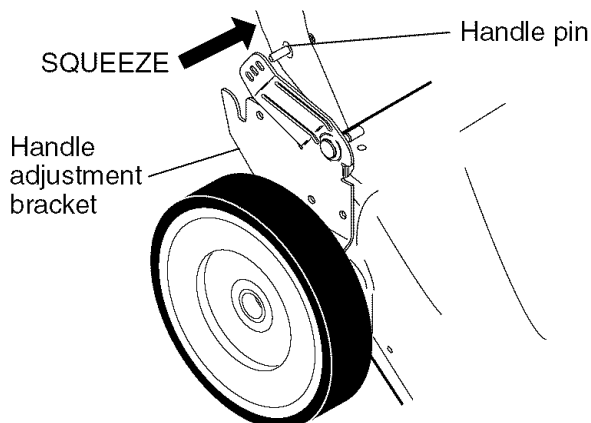

ASSEMBLE GRASS CATCHER (REAR DISCHARGE MOWERS ONLY)

IMPORTANT: If your model lawn mower is mulcher ready, the mulcher plate or plug must be removed before using mower as a bagger. To convert mower to bagging or discharging, see the Operation section in this manual.

Look at the different grass catcher illustrations that follow. Determine which type of grass catcher you have and follow the appropriate instructions.

**“FABRIC TOP” GRASS CATCHERS
TO ASSEMBLE AND ATTACH GRASS
CATCHER**

- Put grass catcher frame into grass bag with rigid part of bag on the bottom.
- Slip vinyl bindings over frame.

NOTE: If vinyl bindings are too stiff, hold them in warm water for a few minutes. If bag gets wet, let it dry before using.

- Lift the rear door on the mower housing.
- For HINGE BRACKET mounted catcher, place the grass catcher frame onto the formed tabs on the rear door hinge bracket.
- For HANDLE BRACKET mounted catcher, place frame side hooks into slots in handle brackets.
- For DOOR PIVOT PIN mounted catcher, place the grass catcher frame hooks onto the door pivot pins.
- For DOOR SLOT mounted catcher, place the grass catcher frame hooks into the slots of the rear door.

NOTE: The grass catcher is secured to the lawn mower housing when the rear door is lowered onto the grass catcher frame.

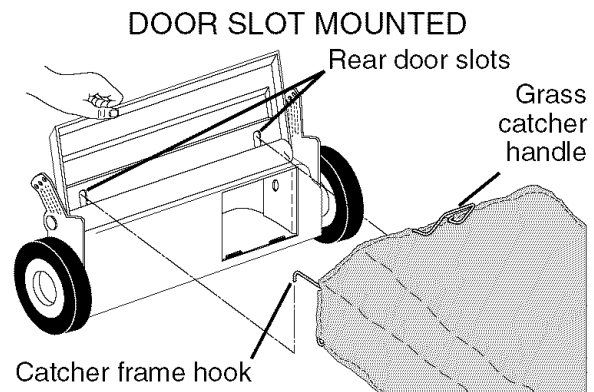
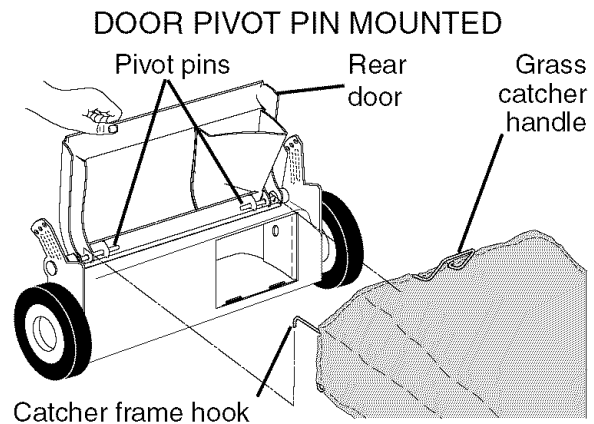
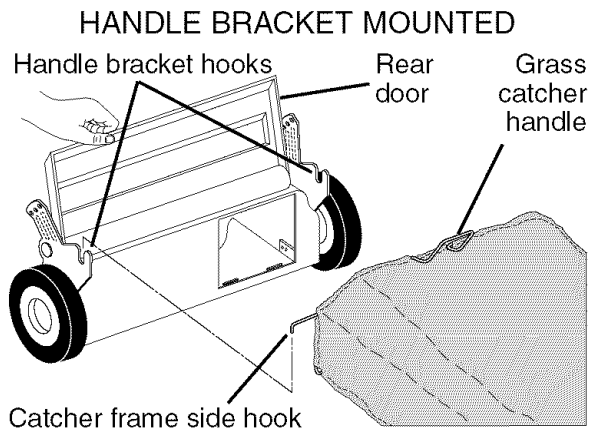
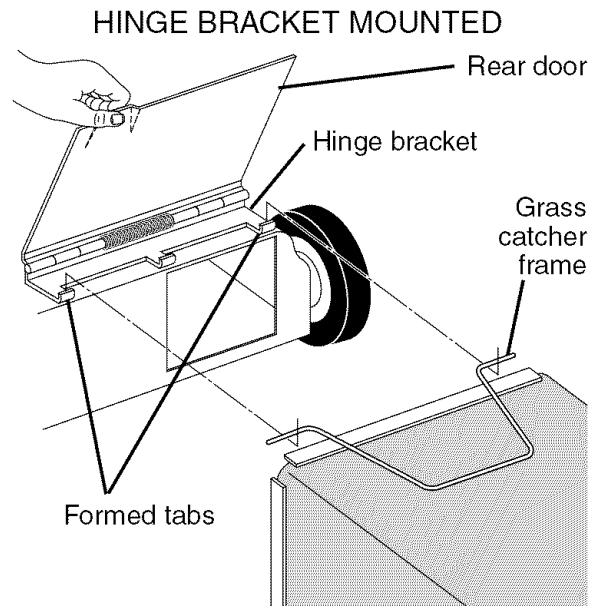
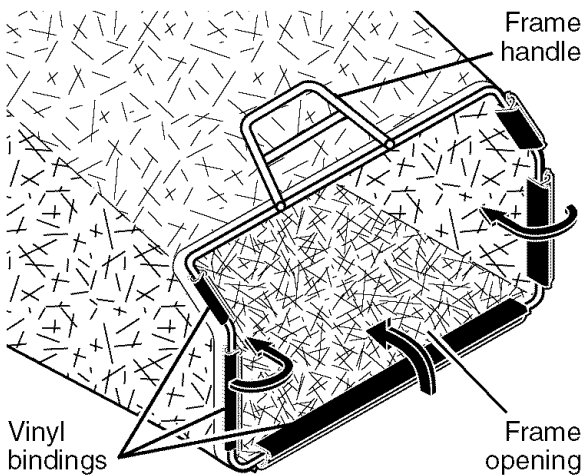

⚠CAUTION: Under normal usage, the catcher material is subject to deterioration and wear and should, therefore, be checked frequently for replacement. Any replacement catcher should be checked to ensure compliance with original manufacturer's specifications.

⚠CAUTION: Do not run lawn mower without the discharge guard (rear door), approved grass catcher, clipping deflector or mulcher plate in place. Never attempt to operate mower with the discharge guard (rear door) removed or propped open.

SPARK PLUG BOOT

On some models a spark plug boot is packed loose in the parts bag. If your model has the boot, install on spark plug wire and reconnect spark plug wire to spark plug.

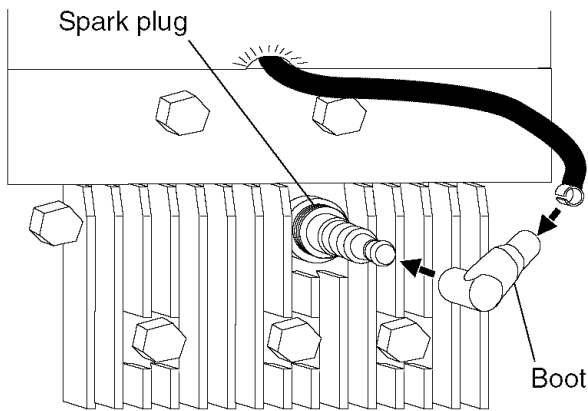

TO PREPARE BATTERY (ELECTRIC START MODELS ONLY)

NOTE: Your battery must be charged before you can start your lawn mower.

UNITS WITH HANDLE-MOUNTED KEY SWITCH ONLY:

- Connect battery charger connector (male) to harness connector (female).

UNITS WITH DECK-MOUNTED BATTERY or TRIMPLATE-MOUNTED KEY SWITCH:

- Disconnect engine connector (male) from battery connector (female).
- Connect battery charger connector (male) to battery connector (female).

ALL UNITS:

- Plug battery charger into 110 volt A.C. outlet.
- Leave battery charger connected for 24 hours before starting your engine for the first time.

UNITS WITH HANDLE-MOUNTED KEY SWITCH ONLY:

- After charging, disconnect harness connector (female) from battery charger connector (male).

Connect your battery charger to charge battery after each use.

IMPORTANT: The engine will not recharge your battery.

UNITS WITH DECK-MOUNTED BATTERY or TRIMPLATE-MOUNTED KEY SWITCH:

- After charging, connect engine connector (male) to battery connector (female).

Your engine has an integral alternator for partial charging. Connect your battery charger to charge battery as required.

IMPORTANT: The engine alternator will not charge a discharged battery.

ALL UNITS:

At the end of the mowing season the battery should be charged for 48 hours to protect the battery during winter storage.

CAUTION: Always disconnect the engine connector (male) from the battery connector (female) to prevent accidental starting when transporting or storing your lawn mower after the season.

HANDLE-MOUNTED KEY SWITCH

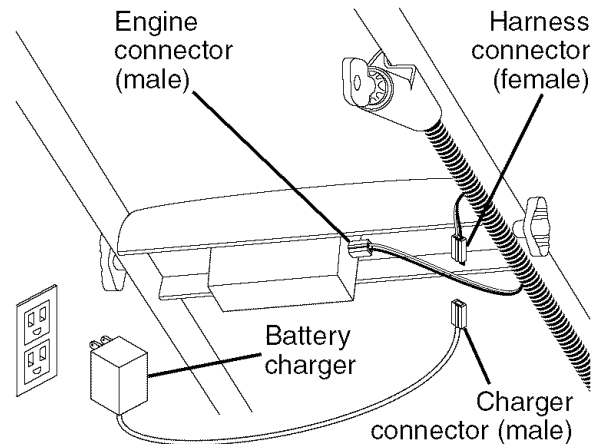

DECK-MOUNTED BATTERY

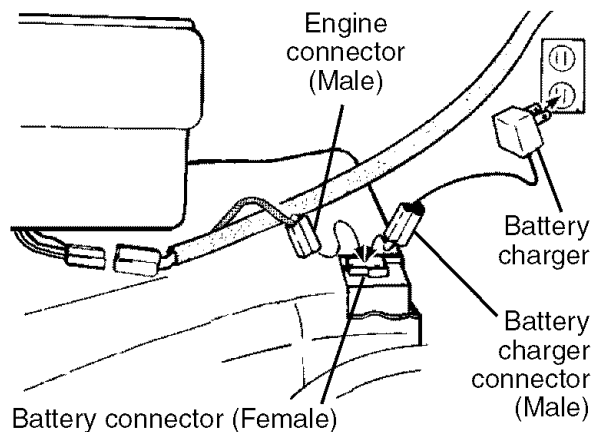

TRIMPLATE-MOUNTED KEY SWITCH

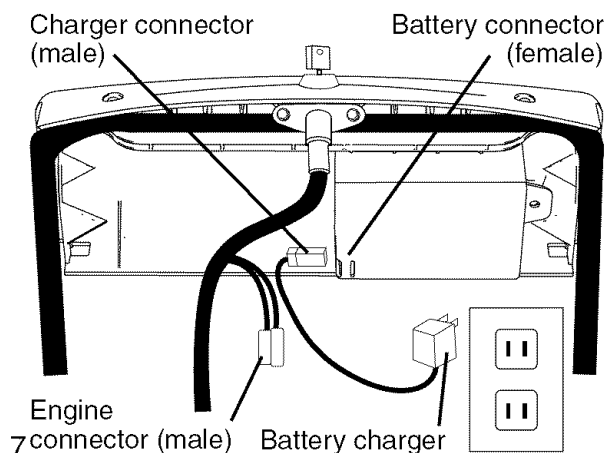

OPERATION



The operation of any lawn mower can result in foreign objects thrown into the eyes, which can result in severe eye damage. Always wear safety glasses or eye shields while operating your lawn mower or performing any adjustments or repairs. We recommend standard safety glasses or a wide vision safety mask worn over spectacles.

HOW TO USE YOUR LAWN MOWER ENGINE SPEED CONTROL

MODELS WITH REMOTE THROTTLE
Engine speed is controlled by the throttle control located on the upper handle.

- Move lever forward to FAST engine speed for starting and better bagging.
- Move lever backward for SLOW engine speed.
- Some models have engines equipped with a choke feature. Move the lever all the way forward to the CHOKE position when starting a cold engine.

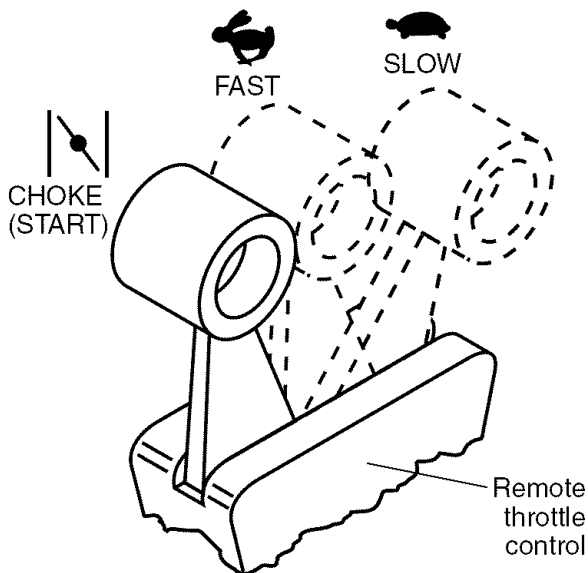

MODELS WITH FIXED SPEED ENGINES
Engine speed was set at the factory for optimum performance. Engine speed is not adjustable.

TO ADJUST CUTTING HEIGHT

Adjust cutting height to suit your requirements. Medium position is best for most lawns. Raise wheels for low cut and lower wheels for high cut.

MODELS WITH MANUAL ADJUST
BOLT-ON WHEELS

- Remove wheel, bolt, and hardware and reassemble in desired adjustment hole.

- Reinstall wheel components in the same order as they were before removal. Tighten securely.
- Make sure all wheels are at same height.

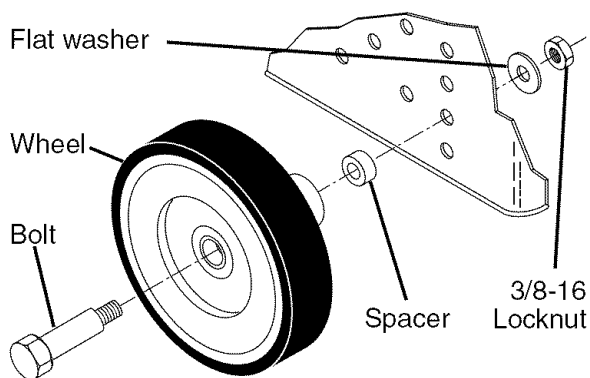

MODELS WITH "QUICK ADJUST"
WHEEL HEIGHT ADJUSTERS

NOTE: For shipping purposes, the rear wheels on your lawn mower may not be adjusted to the same position as the front wheels. Before operating mower adjust all wheels to the same cutting height.

- Raise wheels for low cut and lower wheels for high cut.
- Adjust cutting height to suit your requirements. Medium position is best for most lawns.
- To change cutting height, squeeze adjuster lever toward wheel. Move wheel up or down to suit your requirements. Be sure all wheels are in the same setting.

NOTE: Adjuster is properly positioned when plate tab inserts into hole in lever. Also, 9-position adjusters (if so equipped) allow lever to be positioned between the plate tabs.

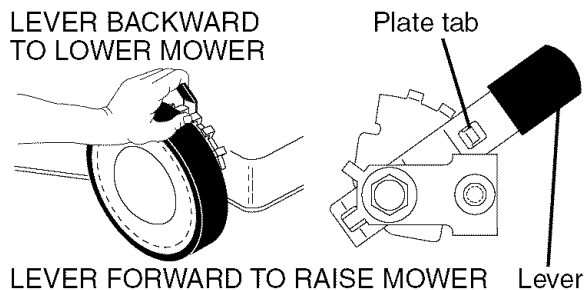

FOR MULCHING MOWERS ONLY

Most mulching mowers are shipped ready to be used as a mulcher.

“REAR DISCHARGE ONLY” MOWERS

Some models have a separate mulcher plug, other models have the mulcher plug built into the rear door. To convert to bagging or discharging, the plate or plug (if so equipped) must be removed from the discharge opening of the lawn mower.

- Open rear door and remove mulcher plate or plug (if so equipped). Store mulcher plate or plug in a safe place.
- You can now install grass catcher or optional clipping deflector accessory.
- To return to mulching operation, install mulcher plate or plug into discharge opening of mower.

⚠CAUTION: Do not run your lawn mower without mulcher plate/plug in place or approved clipping deflector or grass catcher in place. Never attempt to operate the lawn mower with the rear door removed or propped open.

MULCHER PLUG BUILT INTO REAR DOOR

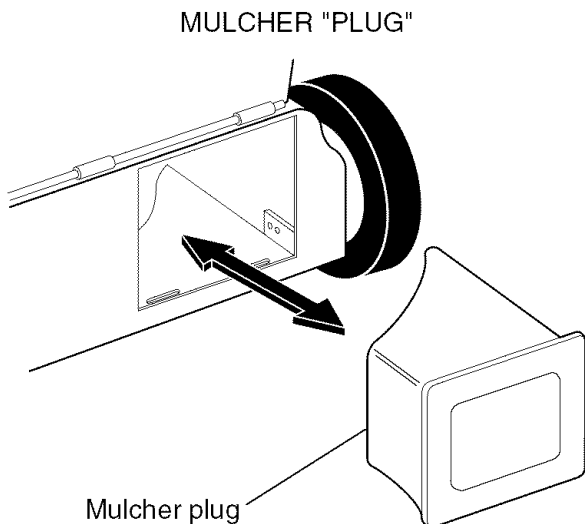
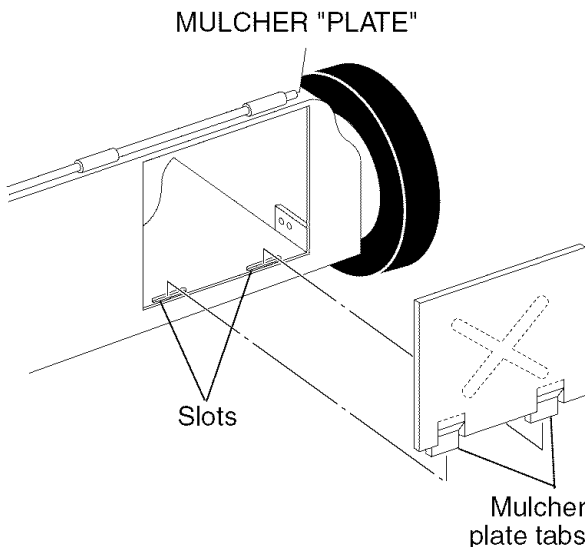
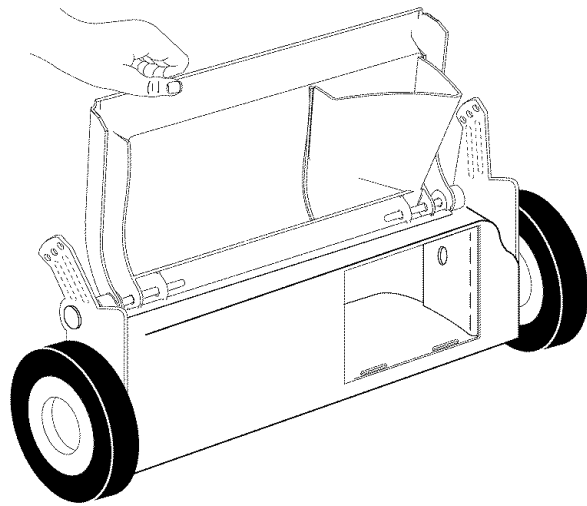

“SIDE DISCHARGE ONLY” MOWERS MULCHER PLATE TYPE

To convert to bagging or discharging, mulcher plate must be removed from underside of lawn mower.

- Remove the four (4) screws and lock nuts securing the mulcher plate to the mower.
- Store mulcher plate and hardware in a safe place.
- Mower can now be used for side discharging or optional grass catcher accessory can be attached.
- To return to mulching operation, simply reinstall mulcher plate and tighten hardware securely.

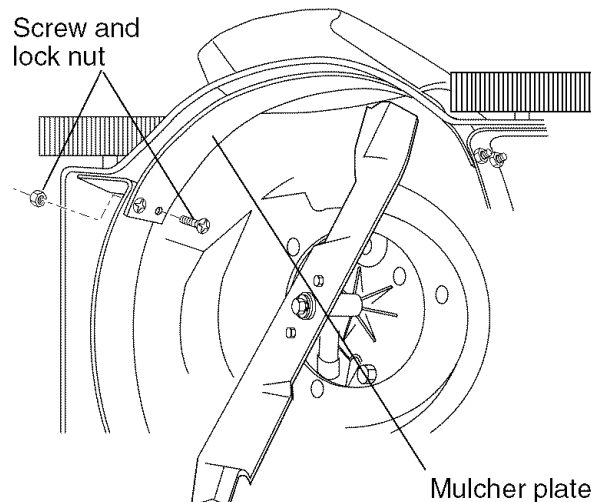

MULCHER PLUG TYPE "A"

To convert to mulching operation, mulcher plug must be installed into discharge opening of mower.

- Open discharge guard.
- Insert tab of mulch plug into housing opening.
- Align hooks of mulch plug over hinge rod of discharge guard. Push mulch plug down until mulch plug is seated in housing opening.

CAUTION: Do not run your lawn mower without discharge guard, approved grass catcher or mulcher plug in place.

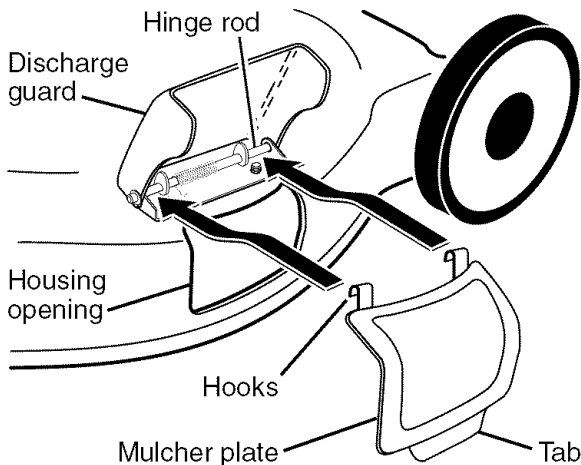

MULCHER PLUG TYPE "B"

To convert to bagging or discharging:

- Lift discharge guard and remove mulcher plug.
- Mower can now be used for side discharging or optional grass catcher can be attached.
- To return to mulching operation, simply reinstall mulcher plug as shown.

CAUTION: Do not run your lawn mower without discharge guard, approved grass catcher or mulcher plug in place.

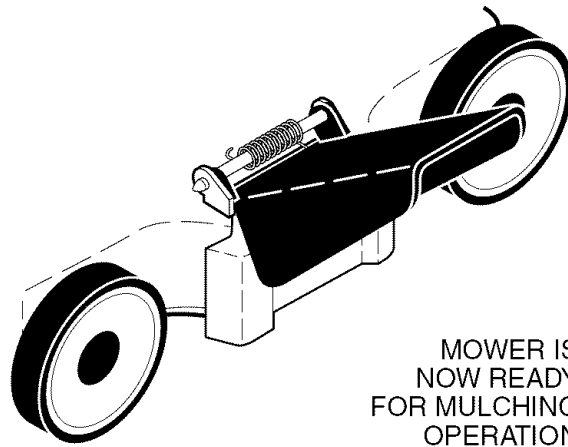
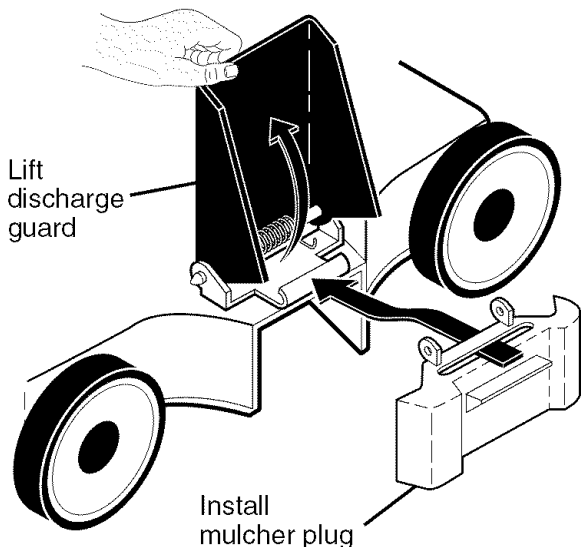

MOWER IS
NOW READY
FOR MULCHING
OPERATION

"COMBI-CUT" MOWERS

Your lawn mower was shipped ready to be used as a mulcher. To convert to bagging or discharging:

REAR BAGGING

- Open rear door and remove mulcher plate. Store mulcher plate in a safe place.
- You can now install grass catcher.
- To convert to mulching or discharging operation, install mulcher plug into rear discharge opening of mower, making sure all tabs are seated properly.

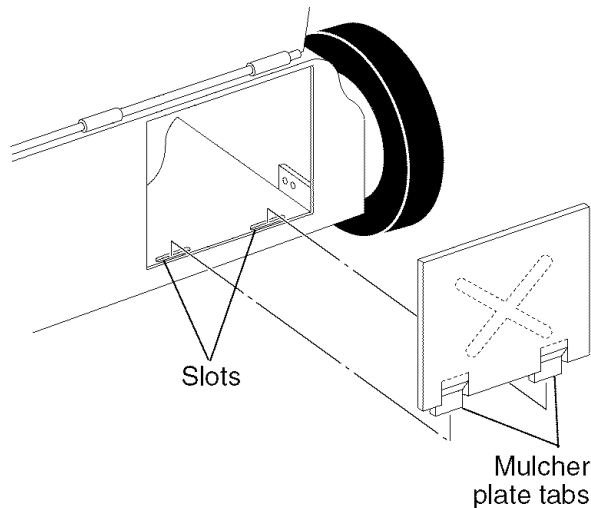

SIDE DISCHARGING

- Mulcher plate must be installed into rear discharge opening of mower (see above instructions).
- Open mulcher door and install discharge deflector under door as shown.
- Mower is now ready for discharging operation.
- To convert to mulching or bagging operation, discharge deflector must be removed and mulcher door must be closed.

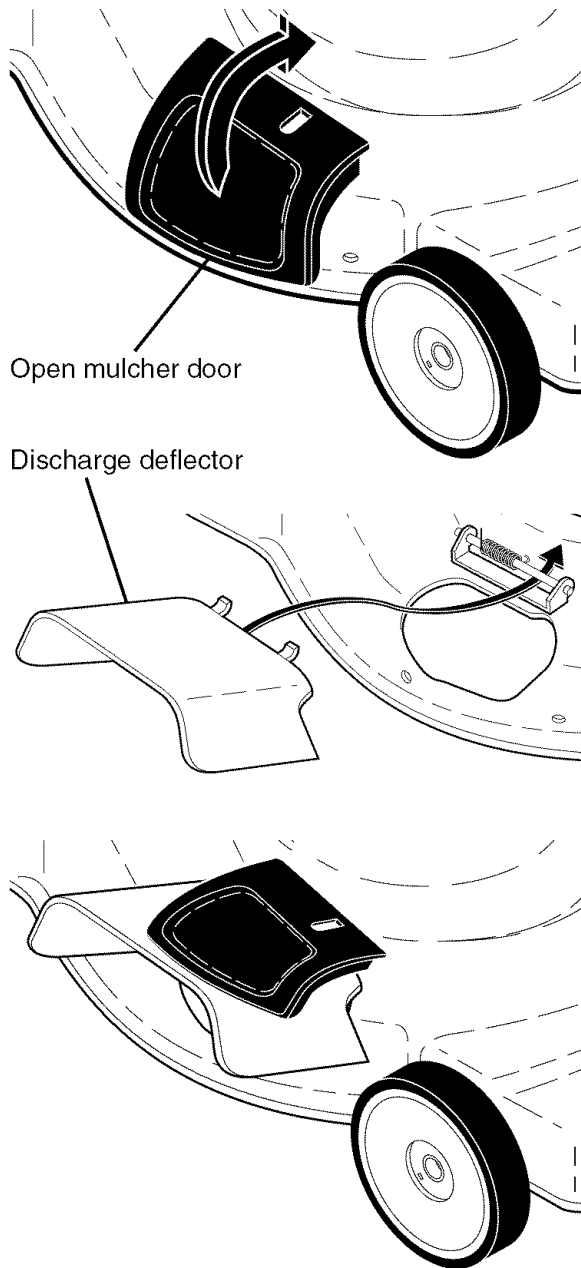

SIMPLE STEPS TO REMEMBER WHEN CONVERTING YOUR "COMBI-CUT" LAWN MOWER

FOR MULCHING -

- Rear mulcher plate installed and rear door closed.
- Mulcher door closed.

FOR REAR BAGGING -

- Rear mulcher plate removed.
- Grass catcher installed.
- Mulcher door closed.

FOR SIDE DISCHARGING -

- Rear mulcher plate installed and rear door closed.
- Discharge deflector installed.

⚠CAUTION: Do not run your lawn mower without rear mulcher plate or plug in place or approved grass catcher in place. Never attempt to operate the lawn mower with the rear door removed or propped open.

GRASS CATCHER (REAR BAGGING MODELS ONLY) TO EMPTY GRASS CATCHER

- Simply open rear door and lift grass catcher up and away from mower.

NOTE: Do not drag the bag when emptying. It will cause unnecessary wear.

⚠CAUTION: Under normal usage, the catcher material is subject to deterioration and wear and should, therefore, be checked frequently for replacement. Any replacement catcher should be checked to ensure compliance with original manufacturer's specifications.

⚠CAUTION: Do not run lawn mower without the rear door, approved grass catcher or clipping deflector in place. Never attempt to operate mower with the rear door removed or propped open.

OPERATOR PRESENCE CONTROL BAR

Your lawn mower is equipped with an operator presence control bar which requires the operator to be positioned behind the lawn mower handle in order to start and operate the lawn mower.

⚠CAUTION: Federal regulations require an engine control to be installed on this lawn mower in order to minimize the risk of blade contact injury. Do not under any circumstances attempt to defeat the function of the operator control. The blade turns when the engine is running.

DRIVE CONTROL

“STANDARD DRIVE” CONTROL

- Self-propelling is controlled by holding the operator presence control bar down to the handle and pushing the drive control lever forward until it clicks; then releasing the lever.
- Forward motion will stop when the operator presence control bar is released. To stop forward motion without stopping engine, release the operator presence control bar slightly until the drive control disengages. Hold operator presence control bar down against handle to continue mowing without self-propelling.
- To keep drive control engaged when turning corners, push down on handle and lift front wheels off ground while turning lawn mower.

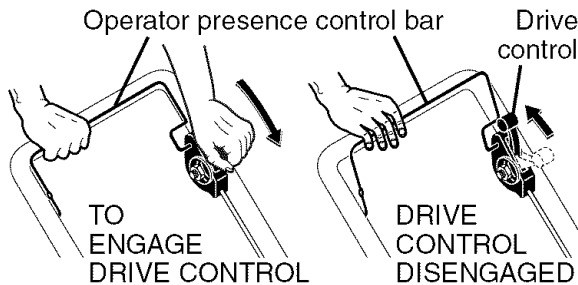

“DUAL BAIL” DRIVE CONTROL

- To start forward motion, lift drive control bar up to handle.
- To stop forward motion, release drive control bar.

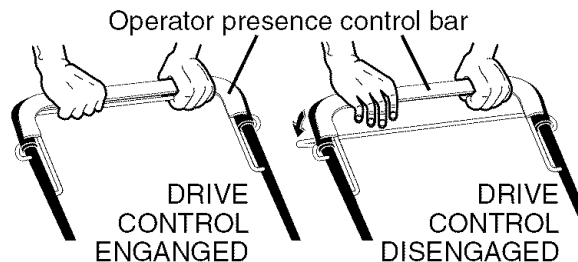

“AUTOWALK” DRIVE CONTROL

- Self-propelling is controlled by holding the operator presence control bar down to the handle and pulling the drive control lever rearward to the handle. The farther toward the handle the lever is pulled, the faster the unit will travel.
- Forward motion will stop when either the operator presence control bar or drive control lever are released. To stop forward motion without stopping engine, release the drive control lever only. Hold operator presence control bar down against handle to continue mowing without self-propelling.

NOTE: If after releasing the drive control the mower will not roll backwards, push the mower forward slightly to disengage drive wheels.

FRONT WHEEL DRIVE MODELS ONLY:

- To keep drive control engaged when turning corners, push down on the handle to lift the front wheels off the ground while turning lawn mower.

“AUTOWALK” ADJUSTMENT

Over time, the drive control system may become “loose”, resulting in decreased speed. There is a turnbuckle on the underside of the drive control housing to increase tension on the drive cable. Proceed as follows:

- Turn unit off and disconnect spark plug wire from spark plug.
- Turn nut on underside of drive control to increase drive speed.
- Operate mower to test drive speed. Readjust as required.
- If condition fails to improve after the above steps (forward speed remains the same), your drive belt is worn and should be replaced.

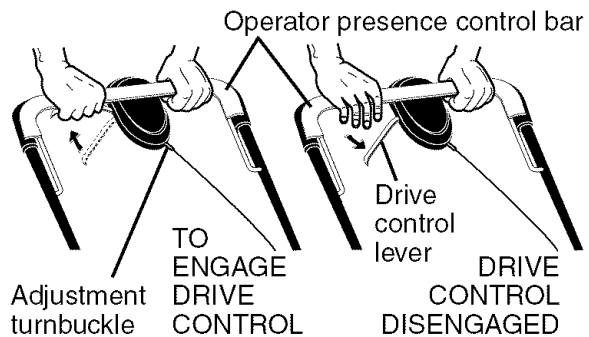

“VARI-SPEED” DRIVE CONTROL

- Self-propelling is controlled by holding the operator presence control bar down to the handle and pulling the drive control bar up to the handle. The closer to the handle the bar is pulled, the faster the unit will travel.
- Forward motion will stop when either the operator presence control bar or drive control bar are released. To stop forward motion without stopping engine, release the drive control bar only. Hold operator presence control bar down against handle to continue mowing without self-propelling.

NOTE: If after releasing the drive control the mower will not roll backwards, push the mower forward slightly to disengage drive wheels.

FRONT WHEEL DRIVE MODELS ONLY:

- To keep drive control engaged when turning corners, push down on the handle to lift the front wheels off the ground while turning lawn mower.

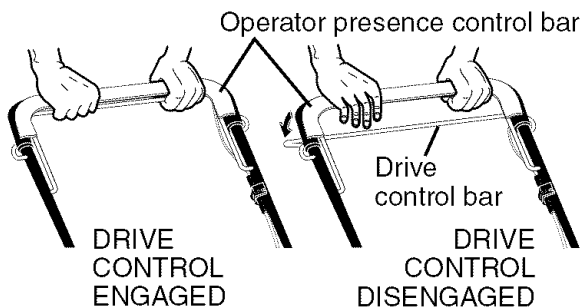

VARI-SPEED “THUMBSCREW” ADJUSTMENT

Over time, the drive control system may become “loose”, resulting in decreased speed. There is a thumbscrew on the underside of the drive control housing to increase tension on the drive cable. Proceed as follows:

- Turn unit off and disconnect spark plug wire from spark plug.
- Rotate thumbscrew counter-clockwise to tighten the drive cable.
- Operate mower to test drive speed.
- If condition fails to improve after the above steps (forward speed remains the same), your drive belt is worn and should be replaced.

NOTE: If mower begins to “creep” forward, the drive cable is too tight. Rotate thumbscrew clockwise to loosen drive cable.

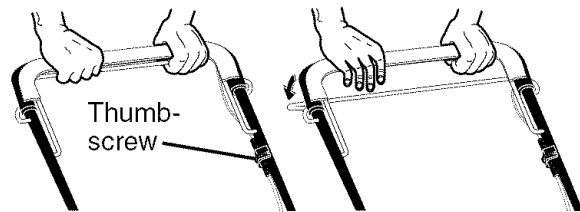

VARI-SPEED “BLOCK” ADJUSTMENT

Over time, the drive control system may become “loose”, resulting in decreased speed. There are holes in the drive control housing to increase tension on the drive cable. Proceed as follows:

1. Turn unit off and disconnect spark plug wire from spark plug.
2. Loosen nut, move drive control housing down handle to the next hole and retighten nut.
3. Operate mower to test drive speed.
4. If condition fails to improve after the above steps (forward speed remains the same), your drive belt is worn and should be replaced.

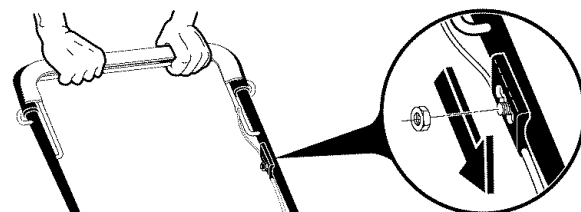

TO ADJUST, MOVE DOWN TO NEXT HOLE

BEFORE STARTING ENGINE

Read the engine manual packed with your mower.

FILL ENGINE WITH OIL

Your lawn mower is shipped without oil in the engine.

- Be sure mower is level and area around oil fill is clean.
- Remove engine oil filler plug (oil fill cap/dipstick on models so equipped).
- Slowly add oil. For type and grade of oil to use, see "ENGINE" in the Maintenance section of this manual.
- Fill to the top of slot in filler hole (to "FULL" line on dipstick on models so equipped). Do not overfill.
- Replace plug (oil fill cap/dipstick on models so equipped) and tighten.
- Check oil level before each use. Add oil as needed.
- To change oil, see Maintenance section of this manual.

FILL GASOLINE TANK

- Fill gasoline tank with fresh, clean, unleaded gasoline. **DO NOT USE PREMIUM GASOLINE. BE CAREFUL NOT TO OVERFILL TANK.**

WARNING: Alcohol blended fuels (called gasohol or using ethanol or methanol) can attract moisture which leads to separation and formation of acids during storage. Acidic gas can damage the fuel system of an engine while in storage. To avoid engine problems, the fuel system should be emptied before storage of 30 days or longer. Drain the fuel tank, start the engine and let it run until fuel lines and carburetor are empty. Use fresh fuel next season. See Storage Instructions for additional information. Never use engine or carburetor cleaner products in fuel tank or permanent damage may occur.

TO START ENGINE

CAUTION: The mower blade rotates whenever the engine is running.

- Move engine speed control to FAST position (or to CHOKE/START position on models equipped with choke feature).
- If your mower has a primer, to start a cold engine, push primer as many times as instructed in the engine manual packed with your mower. Use a firm push. This step is not usually necessary when starting an engine which has already run for a few minutes.
- Hold operator presence control bar down against handle.

MODELS WITH RECOIL STARTER

- Pull starter handle quickly. Do not allow starter rope to snap back.

MODELS WITH ELECTRIC STARTER

- Push the engine start button (or turn the key on models so equipped).

IMPORTANT: Do not crank engine more than five continuous seconds each time you try to start. Wait 5 to 10 seconds between each attempt.

ALL MODELS

- For engines equipped with choke, slowly move engine speed control lever to FAST after engine starts.

TO STOP ENGINE

- To STOP engine, release operator presence control bar.

NOTE: For engines with a primer, it may be necessary to repeat priming steps in cooler weather. In warmer weather, overpriming may cause flooding and engine will not start. If you do flood engine, wait a few minutes before attempting to start and **DO NOT** repeat priming steps.

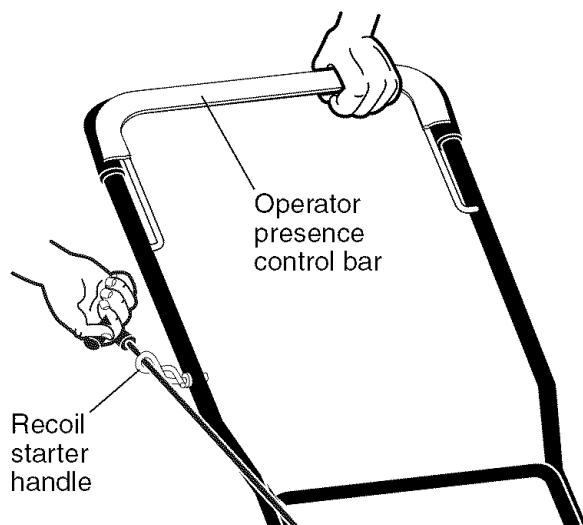

MOWING TIPS

⚠ CAUTION: Do not use de-thatcher blade attachments on your mower. Such attachments are hazardous, will damage your mower and could void your warranty.

- For most cutting conditions and better bagging performance, the engine speed should be set in the FAST position.
- Under certain conditions, such as when mowing very tall grass, raise the mower height on the first cut to reduce pushing effort, to avoid overheating the engine, and to avoid leaving clumps of grass clippings. Make the second cut to the desired height.
- For extremely heavy cutting, reduce the width of cut.
- For side discharge lawn mowers, cut in a counterclockwise direction, starting at the outside of the area to be cut, in order to spread grass clippings more evenly and to put less load on the engine. To keep clippings off of walkways, flower beds, etc., make the first cuts in a clockwise direction.

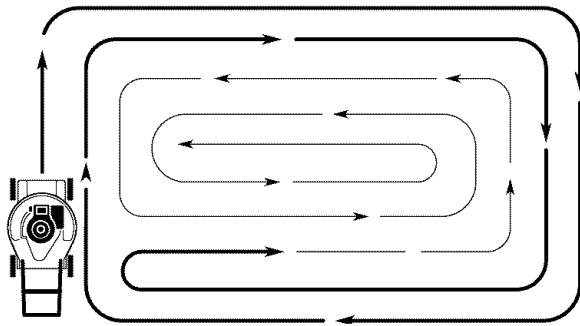

- When using a rear discharge lawn mower in moist, heavy grass, clumps of cut grass may not enter the grass catcher. Reduce ground speed (pushing speed) and/or run the lawn mower over the area a second time.
- If a trail of grass clipping is left on the right side of a rear discharge lawn mower, mow in a clockwise direction with a small overlap to collect the clippings on the next pass.
- Pores in cloth grass catchers can become filled with dirt and dust with use and the catcher will collect less grass. To prevent this, regularly hose catcher off with water and let dry before use.

FOR MULCHING MOWERS ONLY - MULCHING MOWING TIPS

IMPORTANT: For best performance, keep mower housing free of built-up grass and trash. See "CLEANING" in the Maintenance section of this manual.

- The special mulching blade will recut the grass clippings many times and reduce them in size so that as they fall onto the lawn they will disperse into the grass and not be noticed. Also, the mulched grass will biodegrade quickly to provide nutrients for the lawn. Always mulch with your highest engine (blade) speed as this will provide the best recutting action of the blades.
- Avoid cutting your lawn when it is wet. Wet grass tends to form clumps and interferes with the mulching action. The best time to mow your lawn is the early afternoon. At this time the grass has dried, yet the newly cut area will not be exposed to direct sunlight.
- For best results, adjust the lawn mower cutting height so that the lawn mower cuts off only the top one-third of the grass blades. If the lawn is overgrown it will be necessary to raise the height of cut to reduce pushing effort and to keep from overloading the engine and leaving clumps of mulched grass. For extremely heavy grass, reduce your width of cut by overlapping previously cut path and mow slowly.

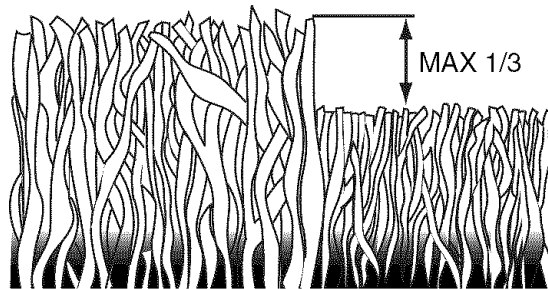

- Certain types of grass and grass conditions may require that an area be mulched a second time to completely hide the clippings. When doing a second cut, mow across (perpendicular) to the first cut path.
- Change your cutting pattern from week to week. Mow north to south one week then change to east to west the next week. This will help prevent matting and graining of the lawn.

MAINTENANCE

MAINTENANCE SCHEDULE		BEFORE EACH USE	AFTER EACH USE	EVERY 10 HOURS	EVERY 25 HOURS OR SEASON	EVERY 100 HOURS	BEFORE STORAGE
LAWN MOWER	Check for Loose Fasteners	✓					✓
	Clean / Inspect Grass Catcher *	✓	✓				✓
	Check Tires	✓					
	Check Drive Wheels ***	✓					
	Clean Lawn Mower ****		✓				✓
ENGINE	Clean under Drive Cover ***			✓			
	Check Drive Belt / Pulleys ***				✓		
	Check / Sharpen / Replace Blade				✓ ₃		
	Lubrication				✓		
	Clean and Recharge Battery **				✓		✓ ₄
ENGINE	Check Engine Oil level	✓ ₅					
	Change Engine Oil				✓ _{1,2}		
	Clean Air Filter				✓ ₂		
	Inspect Muffler				✓		
	Replace Spark Plug					✓	
	Replace Air Filter Paper Cartridge					✓ ₂	
	Empty fuel system or add Stabilizer						✓

- * (if so equipped)
- ** Electric-Start mowers
- *** Power-Propelled mowers
- **** Use a scraper to clean under deck
- 1 - Change more often if operating under a heavy load or in high outdoor temperatures.
- 2 - Service more often if operating in dirty or dusty conditions.
- 3 - Replace blades more often when mowing in sandy soil.
- 4 - Charge 48 hours at end of season.
- 5 - And after each 5 hours of use.

GENERAL RECOMMENDATIONS

The warranty on this lawn mower does not cover items that have been subjected to operator abuse or negligence. To receive full value from the warranty, operator must maintain mower as instructed in this manual. Some adjustments will need to be made periodically to properly maintain your unit. All adjustments in the Service and Adjustments section of this manual should be checked at least once each season.

- Once a year, replace the spark plug, clean or replace air filter element, and check blade for wear. A new spark plug and clean/new air filter element assures proper air-fuel mixture and helps your engine run better and last longer.
- Follow the Maintenance Schedule in this manual.

BEFORE EACH USE

- Check engine oil level.
- Check for loose fasteners.

LUBRICATION

Keep unit well lubricated (See "LUBRICATION CHART").

IMPORTANT: Do not oil or grease plastic wheel bearings. Viscous lubricants will

LUBRICATION CHART

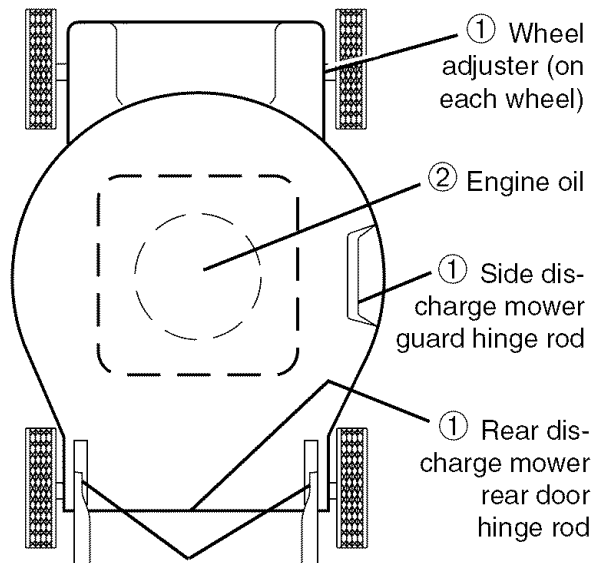

① Handle bracket mounting pins

- ① Spray lubricant
- ② See "ENGINE" in Maintenance section.

attract dust and dirt that will shorten the life of the self-lubricating bearings. If you feel they must be lubricated, use only a dry, powdered graphite type lubricant sparingly.

LAWN MOWER

Always observe safety rules when performing any maintenance.

TIRES

- Keep tires free of gasoline, oil, or insect control chemicals which can harm rubber.
- Avoid stumps, stones, deep ruts, sharp objects and other hazards that may cause tire damage.

BLADE CARE

For best results, mower blade must be kept sharp. Replace a bent or damaged blade.

⚠ CAUTION: Use only a replacement blade approved by the manufacturer of your mower. Using a blade not approved by the manufacturer of your mower is hazardous, could damage your mower and void your warranty.

TO REMOVE BLADE

1. Disconnect spark plug wire from spark plug and place wire where it cannot come in contact with plug.
2. Turn lawn mower on its side. Make sure air filter and carburetor are up.
3. Use a wood block between blade and mower housing to prevent blade from turning when removing blade bolt.

NOTE: Protect your hands with gloves and/or wrap blade with heavy cloth.

4. Remove blade bolt by turning counter-clockwise.
5. Remove blade and attaching hardware (bolt, lock washer and hardened washer).

NOTE: Remove the blade adapter and check the key inside hub of blade adapter. The key must be in good condition to work properly. Replace adapter if damaged.

TO REPLACE BLADE

1. Position the blade adapter on the engine crankshaft. Be sure key in adapter and crankshaft keyway are aligned.
2. Position blade on the blade adapter aligning the two (2) holes in the blade with the raised lugs on the adapter.
3. Be sure the trailing edge of blade (opposite sharp edge) is up toward the engine.
4. Install the blade bolt with the lock washer and hardened washer into blade adapter and crankshaft.

5. Use block of wood between blade and lawn mower housing and tighten the blade bolt, turning clockwise.
- The recommended tightening torque is 35-40 ft. lbs.

IMPORTANT: Blade bolt is heat treated. If bolt needs replacing, replace only with approved bolt shown in the Repair Parts section of this manual.

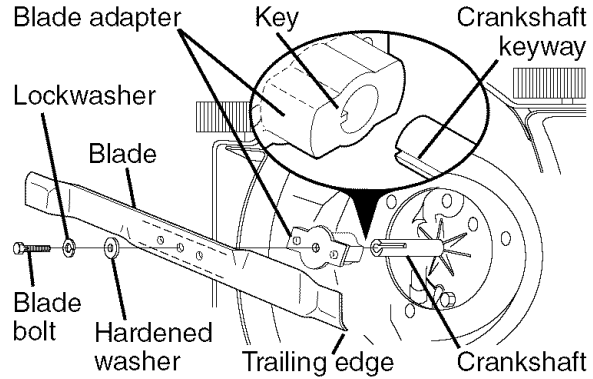

TO SHARPEN BLADE

NOTE: We do not recommend sharpening blade - but if you do, be sure the blade is balanced. An unbalanced blade will cause eventual damage to lawn mower or engine.

- The blade can be sharpened with a file or on a grinding wheel. Do not attempt to sharpen while on the mower.
- To check blade balance, drive a nail into a beam or wall. Leave about one inch of the straight nail exposed. Place center hole of blade over the head of the nail. If blade is balanced, it should remain in a horizontal position. If either end of the blade moves downward, sharpen the heavy end until the blade is balanced.

DRIVE COVER

Clean under the drive cover at least twice a season. Scrape underside of cover with a putty knife or similar tool to remove any buildup of trash or grass.

DRIVE WHEELS

Check drive wheels each time before you mow to be sure they move freely. The wheels not turning freely means trash, grass cuttings, etc. are in the drive wheel area and must be cleaned to free drive wheels.

If necessary to clean the drive wheels, check both drive wheels.

- If after cleaning, the drive wheels do not turn freely, contact your nearest authorized service center.

GEAR CASE

- To keep your drive system working properly, the gear case and area around the drive should be kept clean and free of trash build-up. Clean under the drive cover twice a season.
- The gear case is filled with lubricant to the proper level at the factory. The only time the lubricant needs attention is if service has been performed on the gear case.

GEAR CASE WITH METAL HOUSING:

- If lubricant is required, use only Texaco Starplex Premium 1 Grease, Part No. 750369. Do not substitute.

GEAR CASE WITH PLASTIC HOUSING:

- If lubricant is required, use only ELF Multis EP00. Do not substitute.

ENGINE

Read the maintenance section of your engine manual.

LUBRICATION

Change the oil after the first two hours of operation and every 25 hours thereafter or at least once a year if the lawn mower is not used for 25 hours in one year. Refer to engine manual.

TO CHANGE ENGINE OIL (SEE ENGINE MANUAL)

- Be sure lawn mower is on level surface.
- Oil will drain more freely when warm.
- Catch oil in a suitable container.
- For engines without dipstick, remove bottom oil drain plug.
- For engines with oil fill cap/dipstick, remove bottom drain plug or remove engine oil cap and turn mower on its side.
- After oil has drained completely, replace oil drain plug and tighten securely.
- Refill engine with oil. Pour slowly. Do not overfill.
- Fill to top of slot inside of filler hole or to "FULL" line on dipstick on models so equipped. Keep oil at proper level.

AIR FILTER

Your engine will not run properly and may be damaged by using a dirty air filter. Clean the element after every 25 hours of operation or every season. Replace the air filter every 100 hours of operation or every season, whichever occurs first. Service air cleaner more often under dusty conditions. See the maintenance section of your engine manual.

MUFFLER

Inspect and replace corroded muffler as it could create a fire hazard and/or damage.

SPARK PLUG

Replace spark plug at the beginning of each mowing season or after every 100 hours of operation, whichever occurs first. Set spark plug gap according to engine manual specifications.

CLEANING

IMPORTANT: For best performance, keep mower housing free of grass build-up and trash. Clean the underside of your mower after each use.

- Clean the underside of your lawn mower by scraping to remove buildup of grass and trash.
- Clean engine often to keep trash from accumulating. A clogged engine runs hotter and shortens engine life.
- Keep finished surfaces and wheels free of all gasoline, oil, etc.

We do not recommend using a garden hose to clean your lawn mower unless the electrical system, muffler, air filter, and carburetor are covered to keep water out. Water in engine can shorten engine life.

GRASS CATCHER (IF SO EQUIPPED)

Grass catcher may be hosed with water but must be dry when used.

CAUTION: Under normal usage, the catcher material is subject to deterioration and wear and should therefore be checked to ensure compliance with original manufacturer specifications.

SERVICE AND ADJUSTMENTS

CAUTION: Before performing any service or adjustments:

- Release operator presence control bar.
- Make sure the blade and all moving parts have completely stopped.
- Disconnect spark plug wire from spark plug and place wire where it cannot come in contact with plug.

LAWN MOWER

TO ADJUST CUTTING HEIGHT

See "TO ADJUST CUTTING HEIGHT" in the Operation section of this manual.

TO ADJUST HANDLE

2 POSITION HANDLES

The handle can be mounted in a high or low position. The mounting holes in the bottom of lower handle are off center for raising or lowering the handle.

- Remove upper handle and all parts attached to lower handle.
- Remove hairpin cotters from lower handle bracket mounting pin.
- Squeeze lower handle in to remove it from mounting pins.
- Turn lower handle over to raise or lower handle.
- Squeeze lower handle in and position holes onto mounting pins on handle bracket.
- Reassemble hairpin cotters onto mounting pins.
- Reassemble upper handle and all parts removed from lower handle.

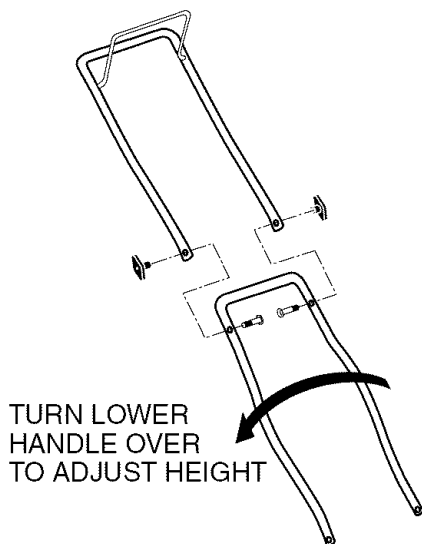
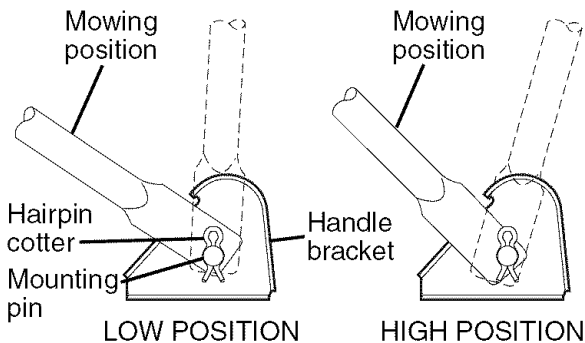

3 POSITION "EZ"

The handle on your lawn mower has three (3) height positions - adjust to height that suits you.

- Remove knob and carriage bolt on one side of the lower handle.
- While holding handle assembly, remove knob and carriage bolt from opposite side, align hole in handle with desired hole in handle bracket and reassemble bolt and knob and tighten securely.
- Align opposite side of handle with same positioning hole and secure with bolt and knob.

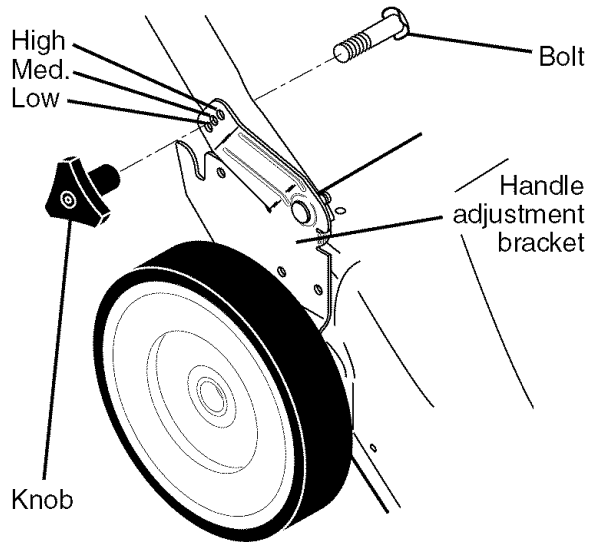

3 POSITION "QUICK"

The handle on your lawn mower has three (3) height positions - adjust to height that suits you.

- Squeeze the bottom ends of lower handle towards each other until the pin in handle can be inserted into one of the three height adjustment holes.

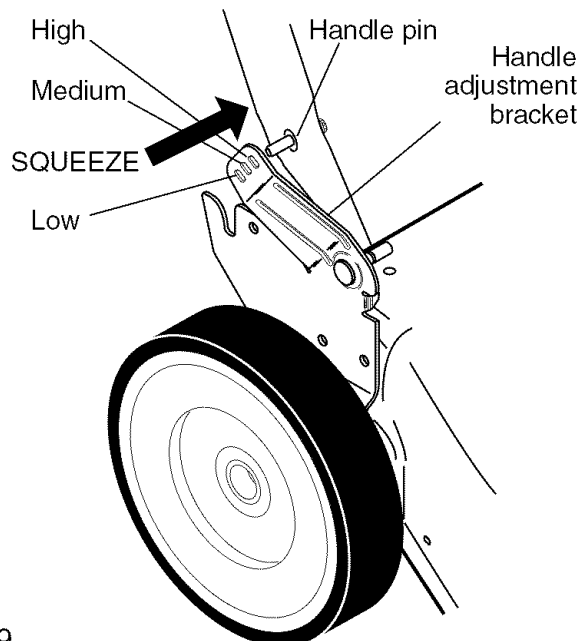

REAR DEFLECTOR (IF EQUIPPED)

The rear deflector, attached between the rear wheels of your mower, is provided to minimize the possibility that objects will be thrown out of the rear of the mower into the operator mowing position. If the deflector becomes damaged, it should be replaced.

TO REMOVE / REPLACE DRIVE BELT

FRONT WHEEL DRIVE MODELS:

- Remove drive cover. Remove belt from gearcase pulley by pushing down on pulley and rolling belt off it.
- Turn lawn mower on its side. See engine manual for proper direction of turning over the engine.
- Remove blade.
- Remove debris shield.
- Remove belt from engine pulley on crankshaft.
- Place new drive belt in the belt retainers of the debris shield (if equipped).
- Install new belt by reversing above steps.

NOTE: Always use factory approved belt to assure fit and long life.

GEAR CASE WITH METAL HOUSING:

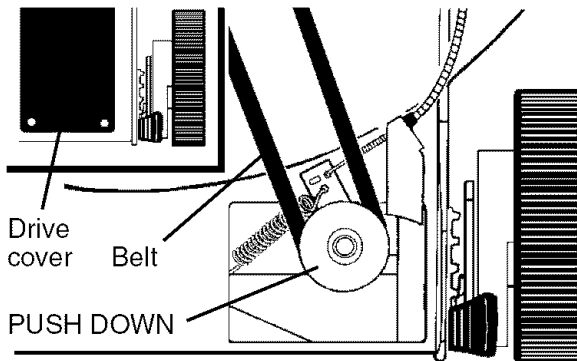

GEAR CASE WITH PLASTIC HOUSING:

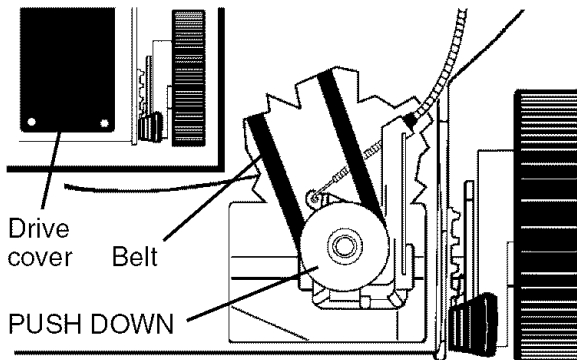

DEBRIS SHIELD WITH BELT RETAINERS:

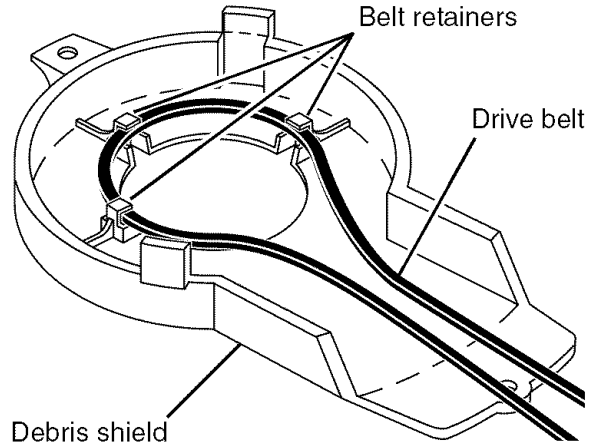

“AUTO WALK” OR “VARI-SPEED” ONLY

- Remove drive cover and belt keeper.
- Remove belt from gearcase pulley by pushing down on pulley and rolling belt off it.
- Turn lawn mower on its side. See engine manual for proper direction of turning over the engine.
- Remove blade and debris shield.
- Remove belt from engine pulley on crankshaft.
- Install new belt by reversing above steps.

NOTE: Always use factory approved belt to assure fit and long life.

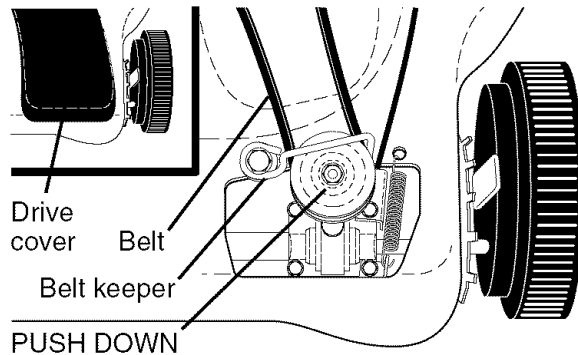

“TORUS” HOUSING ONLY:

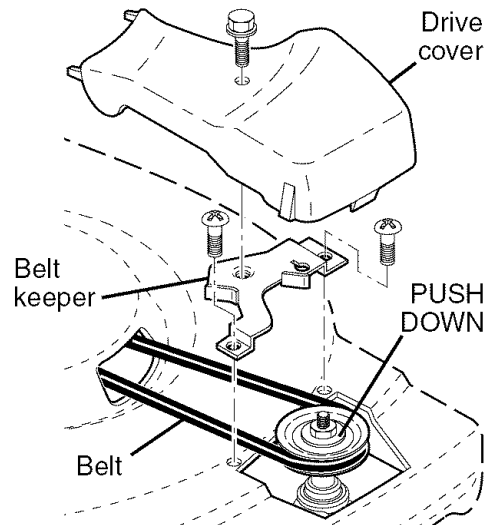

REAR WHEEL DRIVE MODELS:

- Disconnect spark plug wire from spark plug and place wire where it cannot come in contact with plug.
- Remove screws retaining drive cover (not shown); and remove drive cover from lawn mower housing.
- Remove drive cable from anchor, then detach it and return spring (if equipped) from idler arm assembly.
- Remove idler arm assembly from housing by removing hex nut; then remove drive belt from drive pulley, belt keepers and idler arm assembly.

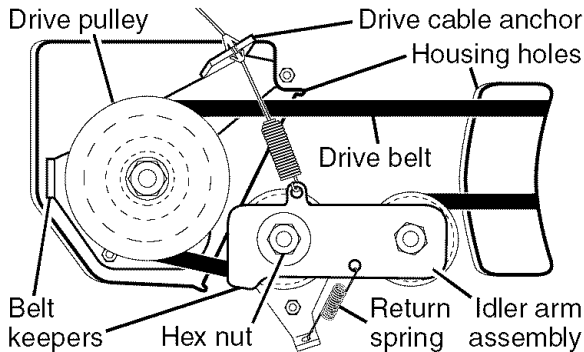

- Turn lawn mower on its side. See engine manual for proper direction of turning over the engine.
- Use a wood block between blade and mower housing to prevent blade from turning when removing blade bolt.

NOTE: Protect your hands with gloves and/or wrap blade with heavy cloth.

- Remove blade bolt.
- Remove blade, attaching hardware (bolt, lock washer, hardened washer), blade adapter and debris shield. Note that the debris shield has a tab which fits into the housing hole.
- Remove drive belt from engine pulley; discard old belt.

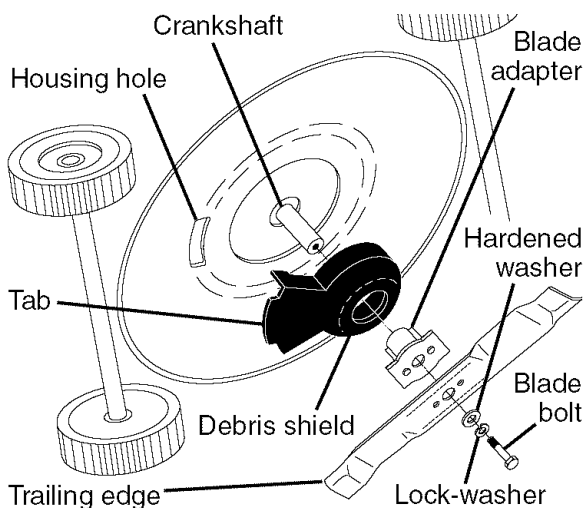

- Install new belt by reversing above steps.

NOTE: Always use factory approved belt to assure fit and long life.

- The recommended tightening torque is 35-40 ft. lbs.

IMPORTANT: Blade bolt is grade 8 heat treated.

ENGINE

CARBURETOR

The carburetor has been preset at the factory and adjustment should not be necessary. However, minor adjustment may be required to compensate for differences in fuel, temperature, altitude or load.

- The air filter must be assembled to the carburetor when running engine.
- Best carburetor adjustment is obtained when fuel tank is 1/4 full.
- In order for the engine to run, the operator presence control bar must be held in the operating position. Therefore, and assistant will be required to hold the control bar in the operating position when making final adjustment to the carburetor.

See the ADJUSTMENT section of your engine manual for further instructions.

ENGINE SPEED

The engine speed has been factory set. Do not attempt to increase engine speed as it may result in personal injury. If you believe the engine is running too fast or too slow, take your lawn mower to an authorized engine service center for repair and adjustment.

THROTTLE CONTROL

If it becomes necessary to adjust or replace the throttle control, see the ADJUSTMENT section of your engine manual.

STORAGE

Immediately prepare your lawn mower for storage at the end of the season or if the unit will not be used for 30 days or more.

CAUTION: Never store the lawn mower with gasoline in the tank inside a building where fumes may reach an open flame or spark. Allow the engine to cool before storing in any enclosure.

LAWN MOWER

When lawn mower is to be stored for a period of time, clean it thoroughly, remove all dirt, grease, leaves, etc. Store in a clean, dry area.

- Clean entire lawn mower (See “CLEANING” in the Maintenance section of this manual).
- Lubricate as shown in the Maintenance section of this manual.
- Be sure that all nuts, bolts, screws, and pins are securely fastened. Inspect moving parts for damage, breakage and wear. Replace if necessary.
- Touch up all rusted or chipped paint surfaces; sand lightly before painting.

HANDLE

Your handle may be folded for storage as shown.

- Squeeze the bottom ends of lower handle towards each other until handle clears the handle brackets and swing handles forward over mower.
- Loosen upper handle mounting hardware enough to allow upper handle to be folded back.

IMPORTANT: When folding handles for storage or transportation, be sure to fold handles as shown or you may damage the control cables.

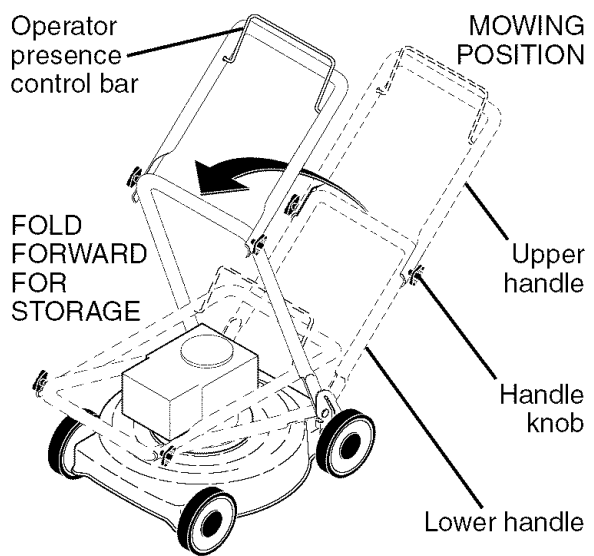
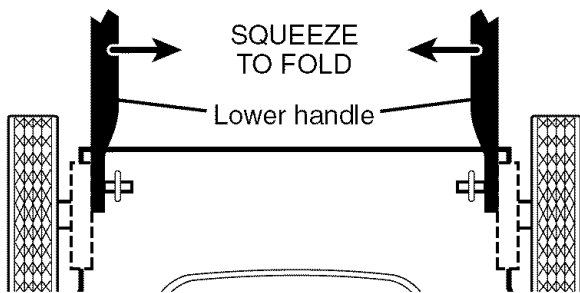

2 POSITION / “ADJUSTABLE” HANDLES

When setting you handles up from the storage position, the lower handle will automatically lock into mowing position.

3 POSITION HANDLES

When setting up your handle from the storage position, the lower handle will require manually locking into the mowing position.

3 POSITION “EZ”

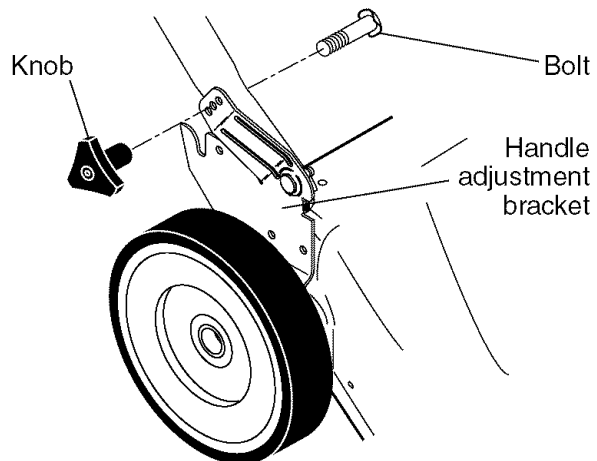

3 POSITION “QUICK”

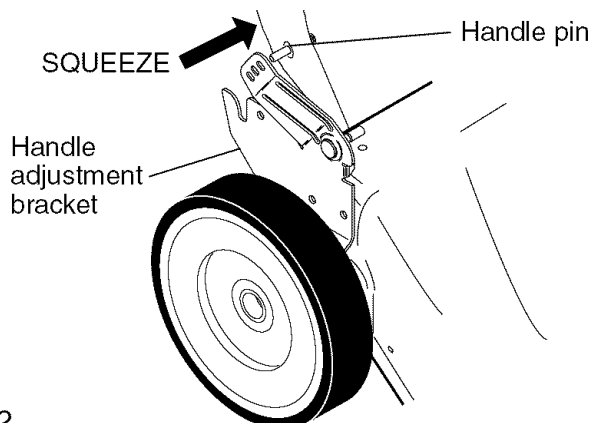

ENGINE

FUEL SYSTEM

IMPORTANT: It is important to prevent gum deposits from forming in essential fuel system parts such as carburetor, fuel filter, fuel hose, or tank during storage. Alcohol blended fuels (called gasohol or using ethanol or methanol) can attract moisture which leads to separation and formation of acids during storage. Acidic gas can damage the fuel system of an engine while in storage.

- Drain the fuel tank.
- Start the engine and let it run until the fuel lines and carburetor are empty.
- Never use engine or carburetor cleaner products in the fuel tank or permanent damage may occur.
- Use fresh fuel next season.

NOTE: Fuel stabilizer is an acceptable alternative in minimizing the formation of fuel gum deposits during storage. Add stabilizer to gasoline in fuel tank or storage container. Always follow the mix ratio found on stabilizer container. Run engine at least 10 minutes after adding stabilizer to allow the stabilizer to reach the carburetor. Do not drain the gas tank and carburetor if using fuel stabilizer.

ENGINE OIL

Drain oil (with engine warm) and replace with clean oil. (See "ENGINE" in the Maintenance section of this manual).

CYLINDER

- Remove spark plug.
- Pour one ounce (29 ml) of oil through spark plug hole into cylinder.
- Pull starter handle slowly to distribute oil.
- Replace with new spark plug.

BATTERY (IF EQUIPPED)

Disconnect the battery from the engine connector and charge battery 48 hours.

OTHER

- Do not store gasoline from one season to another.
- Replace your gasoline can if your can starts to rust. Rust and/or dirt in your gasoline will cause problems.
- If possible, store your unit indoors and cover it to protect it from dust and dirt.
- Cover your unit with a suitable protective cover that does not retain moisture. Do not use plastic. Plastic cannot breathe, which allows condensation to form and will cause your unit to rust.

IMPORTANT: Never cover mower while engine and exhaust areas are still warm.

CAUTION: Never store the lawn mower with gasoline in the tank inside a building where fumes may reach an open flame or spark. Allow the engine to cool before storing in any enclosure.

TROUBLESHOOTING - See appropriate section in manual unless directed to an authorized Service Center.

PROBLEM	CAUSE	CORRECTION
Does not start	<ol style="list-style-type: none">1. Dirty air filter.2. Out of fuel.3. Stale fuel. 4. Water in fuel. 5. Spark plug wire is disconnected.6. Bad spark plug.7. Loose blade or broken blade adapter.8. Control bar in released position.9. Control bar defective.10. Fuel valve lever (if so equipped) in OFF position.11. Weak battery (if equipped).12. Disconnected battery connector (if equipped).	<ol style="list-style-type: none">1. Clean/replace air filter.2. Fill fuel tank.3. Drain fuel tank and refill tank with fresh, clean gasoline.4. Drain fuel tank and refill tank with fresh, clean gasoline.5. Connect wire to plug. 6. Replace spark plug.7. Tighten blade bolt or replace blade adapter.8. Depress control bar to handle.9. Replace control bar.10. Turn fuel valve lever to the ON position.11. Charge battery.12. Connect battery to engine.

TROUBLESHOOTING - See appropriate section in manual unless directed to an authorized Service Center.

PROBLEM	CAUSE	CORRECTION
Loss of power	<ol style="list-style-type: none"> 1. Rear of lawn mower housing or cutting blade dragging in heavy grass. 2. Cutting too much grass. 3. Dirty air filter. 4. Buildup of grass, leaves, and trash under mower. 5. Too much oil in engine. 6. Walking speed too fast. 	<ol style="list-style-type: none"> 1. Raise cutting height. 2. Raise cutting height. 3. Clean/replace air filter. 4. Clean underside of mower housing. 5. Check oil level. 6. Cut at slower walking speed.
Poor cut – uneven	<ol style="list-style-type: none"> 1. Worn, bent or loose blade. 2. Wheel heights uneven. 3. Buildup of grass, leaves and trash under mower. 	<ol style="list-style-type: none"> 1. Replace blade. Tighten blade bolt. 2. Set all wheels at same height. 3. Clean underside of mower housing.
Excessive vibration	<ol style="list-style-type: none"> 1. Worn, bent or loose blade. 2. Bent engine crankshaft. 	<ol style="list-style-type: none"> 1. Replace blade. Tighten blade bolt. 2. Contact a qualified service center.
Starter rope hard to pull	<ol style="list-style-type: none"> 1. Engine flywheel brake is on when control bar is released. 2. Bent engine crankshaft. 3. Blade adapter broken. 4. Blade dragging in grass. 	<ol style="list-style-type: none"> 1. Depress control bar to upper handle before pulling starter rope. 2. Contact a qualified service center. 3. Replace blade adapter. 4. Move lawn mower to cut grass or to hard surface.
Grass catcher not filling (If so equipped)	<ol style="list-style-type: none"> 1. Cutting height too low. 2. Lift on blade worn off. 3. Catcher not venting air. 	<ol style="list-style-type: none"> 1. Raise cutting height. 2. Replace blade. 3. Clean grass catcher.
Hard to push	<ol style="list-style-type: none"> 1. Grass is too high or wheel height is too low. 2. Rear of lawn mower housing or cutting blade dragging in grass. 3. Grass catcher too full. 4. Handle height position not right for you. 	<ol style="list-style-type: none"> 1. Raise cutting height. 2. Raise rear of lawn mower housing one (1) setting higher. 3. Empty grass catcher. 4. Adjust handle height to suit.
Loss of drive or slowing of drive speed	<ol style="list-style-type: none"> 1. Belt wear. 2. Belt off of pulley. 3. Drive cable worn or broken. 4. “Loose” drive control system. 	<ol style="list-style-type: none"> 1. Check/replace drive belt. 2. Check/reinstall drive belt. 3. Replace drive cable. 4. Adjust drive control.