



# Room Air Conditioners

*Safety Instructions* .....2, 3

*Operating Instructions* .....4, 5

*Care and Cleaning* .....6

*Installation Instructions*

Preparing to Install the  
Air Conditioner .....7

Window Installation .....8-12

*Troubleshooting Tips* .....13-15

Normal Operating Sounds .....15

*Consumer Support*

Consumer Support . . . .Back Cover

Product Registration .....17, 18

Warranty .....19

**Owner's Manual and  
Installation Instructions**

AGE14  
AGE18  
AGE21

**Write the model and serial numbers here:**

**Model #** \_\_\_\_\_

**Serial #** \_\_\_\_\_

Find these numbers on a label on the side of the air conditioner.

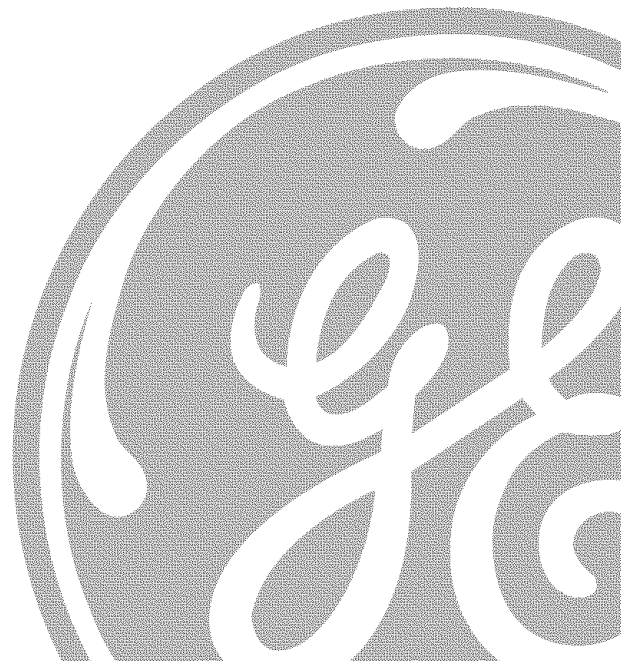

# IMPORTANT SAFETY INFORMATION. READ ALL INSTRUCTIONS BEFORE USING.

## **⚠ WARNING!**

For your safety, the information in this manual must be followed to minimize the risk of fire, electric shock or personal injury.

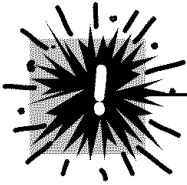

## SAFETY PRECAUTIONS

- Use this appliance only for its intended purpose as described in this Owner's Manual.
- This air conditioner must be properly installed in accordance with the Installation Instructions before it is used.
- Never unplug your air conditioner by pulling on the power cord. Always grip plug firmly and pull straight out from the receptacle.
- Replace immediately all electric service cords that have become frayed or otherwise damaged. A damaged power supply cord must be replaced with a new power supply cord obtained from the manufacturer and not repaired. Do not use a cord that shows cracks or abrasion damage along its length or at either the plug or connector end.
- Turn the unit **OFF** and unplug your air conditioner before making any repairs or cleaning.
- **NOTE:** We strongly recommend that any servicing be performed by a qualified individual.
- For your safety...do not store or use combustible materials, gasoline or other flammable vapors or liquids in the vicinity of this or any other appliance.
- All air conditioners contain refrigerants, which under federal law must be removed prior to product disposal. If you are getting rid of an old product with refrigerants, check with the company handling disposal about what to do.

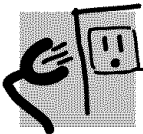

## HOW TO CONNECT ELECTRICITY

*Do not, under any circumstances, cut or remove the third (ground) prong from the power cord. For personal safety, this appliance must be properly grounded.*

The power cord of this appliance is equipped with a 3-prong (grounding) plug which mates with a standard 3-prong (grounding) wall outlet to minimize the possibility of electric shock hazard from this appliance.

Power cord includes a current interrupter device. A test and reset button is provided on the plug case. The device should be tested on a periodic basis by first pressing the **TEST** button and then the **RESET** button. If the **TEST** button does not trip or if the **RESET** button will not stay engaged, discontinue use of the air conditioner and contact a qualified service technician.

Have the wall outlet and circuit checked by a qualified electrician to make sure the outlet is properly grounded.

Where a 2-prong wall outlet is encountered, it is your personal responsibility and obligation to have it replaced with a properly grounded 3-prong wall outlet.

The air conditioner should always be plugged into its own individual electrical outlet which has a voltage rating that matches the rating plate.

This provides the best performance and also prevents overloading house wiring circuits which could cause a fire hazard from overheated wires.

See the Installation Instructions, *Electrical Requirements* section for specific electrical connection requirements.

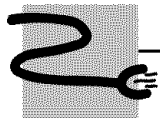
**⚠ WARNING!****USE OF EXTENSION CORDS—115-Volt models only**

*Because of potential safety hazards under certain conditions, we strongly recommend against the use of an extension cord.*

However, if you must use an extension cord, it is absolutely necessary that it be a UL-listed, 14 gauge, 3-wire grounding type appliance extension cord having a grounding type plug and outlet and that the electrical rating of the cord be 15 amperes (minimum) and 125 volts.

**⚠ CAUTION:** *DO NOT use an extension cord with any of the 230/208 volt models.*

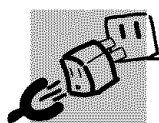
**USE OF ADAPTER PLUGS—115-Volt models only**

*Because of potential safety hazards under certain conditions, we strongly recommend against the use of an adapter plug.*

However, if you must use an adapter, where local codes permit, a **temporary connection** may be made to a properly grounded 2-prong wall outlet by use of a UL-listed adapter available at most local hardware stores.

The larger slot in the adapter must be aligned with the larger slot in the wall outlet to provide proper polarity in the connection of the power cord.

When disconnecting the power cord from the adapter, always hold the adapter in place with one hand while pulling the power cord plug with the other hand. If this is not done, the adapter ground terminal is very likely to break with repeated use.

If the adapter ground terminal breaks, **DO NOT USE** the air conditioner until a proper ground has been established.

*Attaching the adapter ground terminal to a wall outlet cover screw does not ground the appliance unless the cover screw is metal, and not insulated, and the wall outlet is grounded through the house wiring. You should have the circuit checked by a qualified electrician to make sure the outlet is properly grounded.*



**READ AND FOLLOW THIS SAFETY INFORMATION CAREFULLY.**

**SAVE THESE INSTRUCTIONS**

## About the controls on the air conditioner.

Features and appearance will vary.

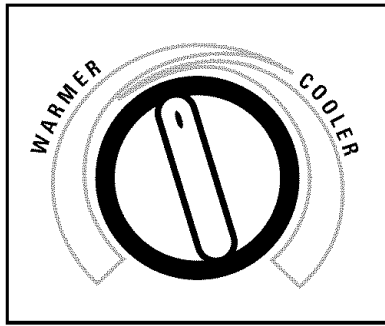

### TEMP CONTROL

1

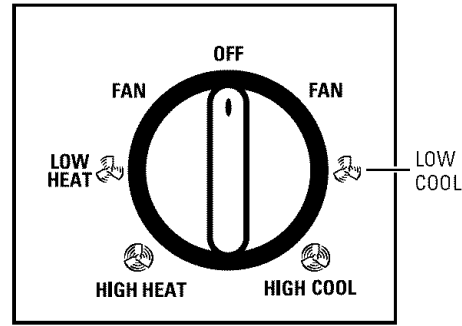

### MODE CONTROL

2



## Controls

### 1 Temp Control

The temp control is used to maintain the room temperature. The compressor will cycle on and off to keep the room at the same level of comfort. Turn the knob clockwise to **COOLER** (blue) and the indoor air will become cooler. Turn the knob counterclockwise to **WARMER** (red) and the indoor air will become warmer.

### 2 Mode Control

**HIGH COOL** and **LOW COOL** provide cooling with different fan speeds.

**HIGH HEAT** and **LOW HEAT** provide heating with different fan speeds.

**FAN** settings provide air circulation and filtering without cooling or heating.

**NOTE:** If you move the mode control from a cool setting to **OFF**, a fan setting, or a heat setting wait at least 3 minutes before switching back to a cool setting.

#### Cooling Descriptions

**For Normal Cooling**—Select **HIGH COOL** or **LOW COOL** with the temp control at midpoint.

**For Maximum Cooling**—Select **HIGH COOL** with the temp control turned clockwise as far as possible.

**For Quieter & Nighttime Cooling**—Select **LOW COOL** with the temp control at midpoint.

#### Heating Descriptions

**For Normal Heating**—Select **HIGH HEAT** or **LOW HEAT** with the temp control at midpoint.

**For Maximum Heating**—Select **HIGH HEAT** with the temp control turned counterclockwise as far as possible.

**For Quieter & Nighttime Heating**—Select **LOW HEAT** with the temp control at midpoint.

## Additional controls and important information.

### Vent Control

The vent control is located above the control knobs.

To open the vent, pull the lever toward you. To close it, push it in.

When set at **CLOSE**, only the air inside the room will be circulated and conditioned. When set at **OPEN**, some inside air is exhausted outside.

### Air Direction—Side-to-Side

**CIRCULAIRE** (on some models)

For fixed side-to-side air direction, set the Circulaire switch to **ON** until the desired air direction is obtained, then move it to **OFF**.

For continuous side-to-side air circulation (cool settings only), set the Circulaire switch to **ON**.

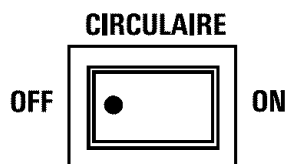

### Air Direction—Up and Down

Fingertip pressure on the bank of horizontal louvers adjusts the air direction up or down.

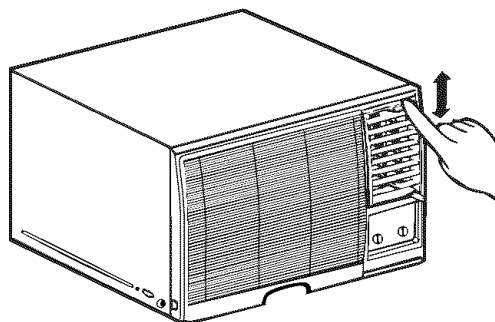

### Water Drain Valve

When the outside temperature drops below 58°F and the unit is set for heating, a drain valve opens up to release water from the base pan. This is normal and prevents water from freezing in the base pan and interfering with the outdoor fan.

## Care and cleaning of the air conditioner.

### Grille and Case

Turn the air conditioner off and remove the plug from the wall outlet before cleaning.

To clean, use water and a mild detergent. Do not use bleach or abrasives.

### Outdoor Coils

The coils on the outdoor side of the air conditioner should be checked regularly. If they are clogged with dirt or soot they may be professionally cleaned.

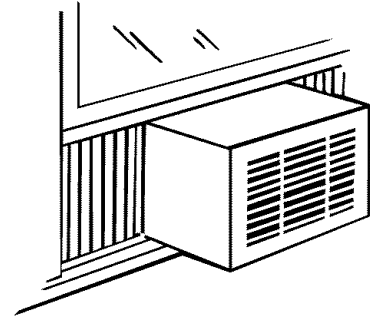

### Air Filter

The air filter behind the front grille should be checked and cleaned at least every 30 days or more often if necessary.

Clean the filter with warm, soapy water. Rinse and let the filter dry before replacing it.

**⚠ CAUTION:** DO NOT operate the air conditioner without a filter because dirt and lint will clog it and reduce performance.

#### To remove (on some models):

- 1 Open the inlet grille upward by pulling out the bottom of the inlet grille.
- 2 Using the tab, pull up slightly on the filter to release it and pull it down.

#### To remove (on some models):

- 1 Open the inlet grille downward by pulling out the top of the inlet grille.
- 2 Using the tab, push down slightly on the filter to release it and pull it up.

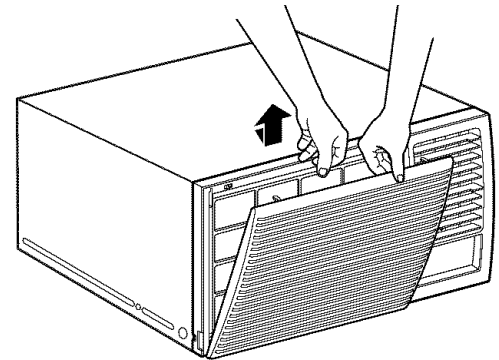
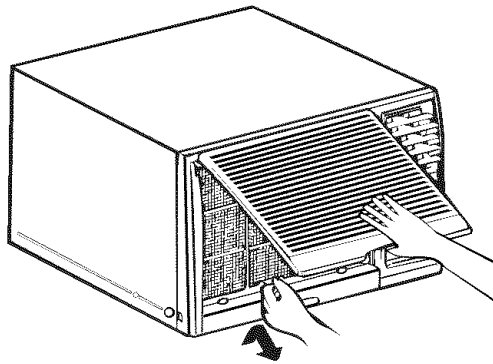

# Installation Instructions

# Air Conditioner

? Questions? Call 800.GE.CARES (800.432.2737) or Visit our Website at: [ge.com](http://ge.com)



## BEFORE YOU BEGIN

Read these instructions completely and carefully.

- **IMPORTANT** — Save these instructions for local inspector's use.
- **IMPORTANT** — Observe all governing codes and ordinances.
- **Note to Installer** – Be sure to leave these instructions with the Consumer.
- **Note to Consumer** – Keep these instructions for future reference.
- **Skill level** – Installation of this appliance requires basic mechanical skills.
- **Completion time** – Approximately 1 hour
- We recommend that two people install this product.
- Proper installation is the responsibility of the installer.
- Product failure due to improper installation is not covered under the Warranty.



## ELECTRICAL REQUIREMENTS



Some models require a 115/120-volt a.c., 60 Hz grounded outlet protected with a 15-amp time delay fuse or circuit breaker.

The 3-prong grounding plug minimizes the possibility of electric shock hazard. If the wall outlet you plan to use is only a 2-prong outlet, it is your responsibility to have it replaced with a properly grounded 3-prong wall outlet.



Some models require 230/208-volt a.c., protected with a time delay fuse or circuit breaker. These models should be installed



on their own single branch circuit for best performance and to prevent overloading house or apartment wiring circuits, which could cause a possible fire hazard from overheating wires.

## CAUTION:

Do not, under any circumstances, cut or remove the third (ground) prong from the power cord.

Do not change the plug on the power cord of this air conditioner.

Aluminum house wiring may present special problems—consult a qualified electrician.

## TOOLS YOU WILL NEED

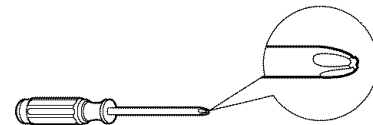

Phillips head screwdriver



Flat-blade screwdriver



Pencil

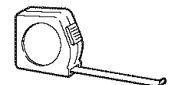

Ruler or tape measure



Level



Scissors or knife

Power cord includes a current interrupter device. A test and reset button is provided on the plug case. The device should be tested on a periodic basis by first pressing the **TEST** button and then the **RESET** button. If the **TEST** button does not trip or if the **RESET** button will not stay engaged, discontinue use of the air conditioner and contact a qualified service technician.

# Installation Instructions

## PARTS INCLUDED (Appearance may vary)

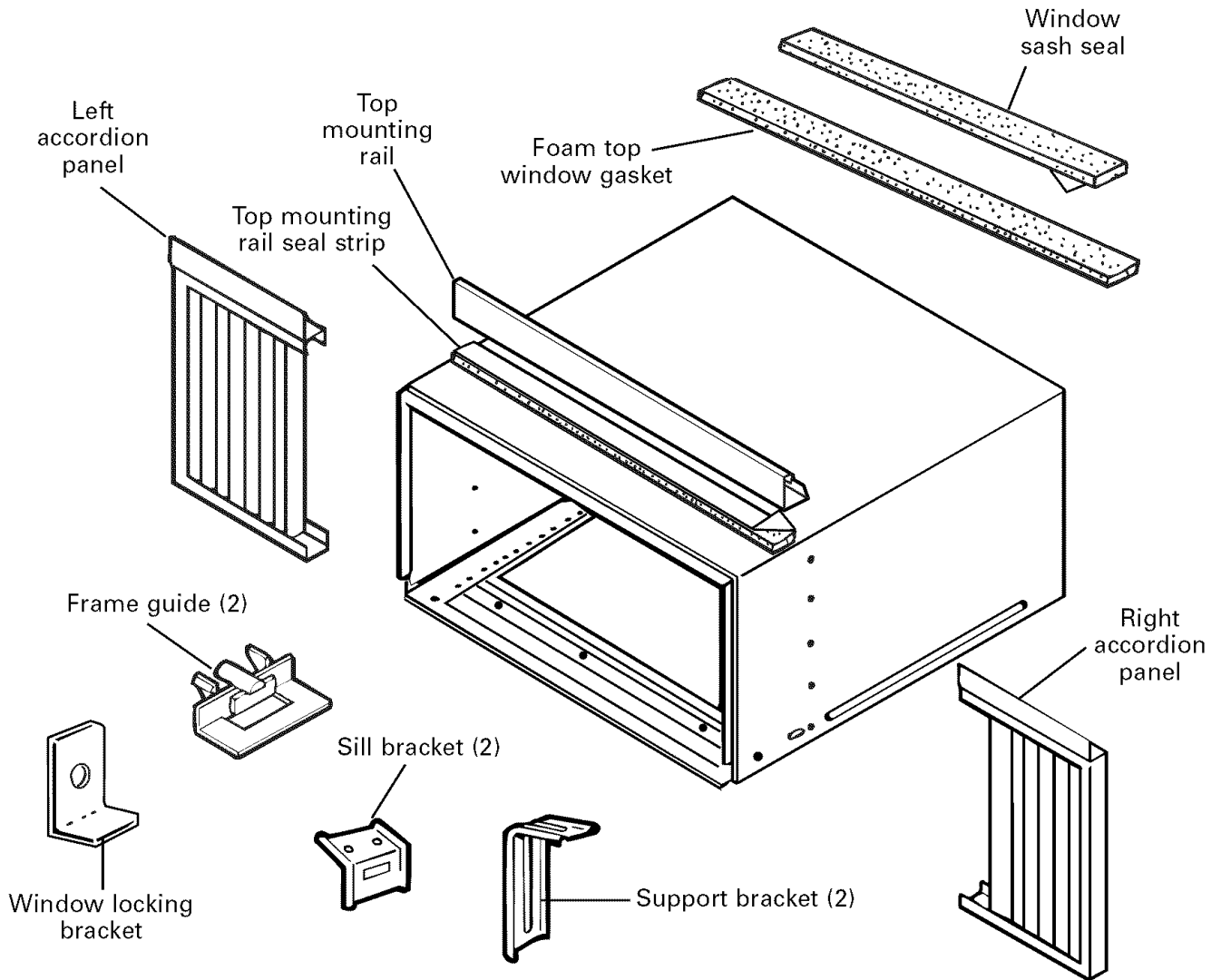

Type A (14)



Type B (7)

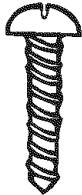

Type C (5)



Type D (2)



Carriage Bolt (2)



Lock Nut (4)





# Installation Instructions

## 1 WINDOW REQUIREMENTS

- These instructions are for a standard double-hung window. You will need to modify them for other types of windows.
- The air conditioner can be installed without the accordion panels if needed to fit in a narrow window. See the window opening dimensions.
- All supporting parts must be secured to firm wood, masonry or metal.
- The electrical outlet must be within reach of the power cord.

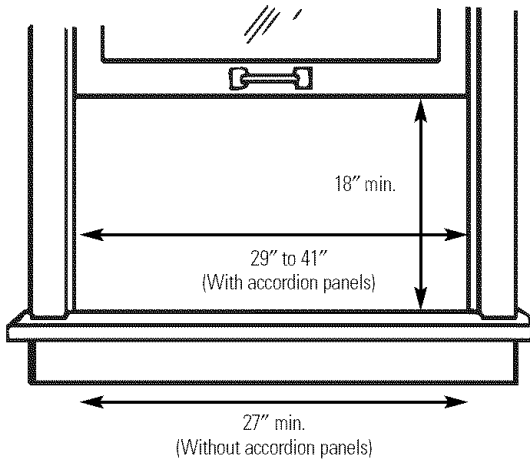

## 2 STORM WINDOW REQUIREMENTS

A storm window frame will not allow the air conditioner to tilt toward the outside, and will keep it from draining properly. To adjust for this, attach a piece of wood to the stool.

### WOOD PIECES—

**WIDTH:** 2"

**LENGTH:** Long enough to fit inside the window frame.

**THICKNESS:** To determine the thickness, place a piece of wood on the stool to make it 1/2" higher than the top of the storm window frame.

Attach securely with nails or screws provided by the installer.

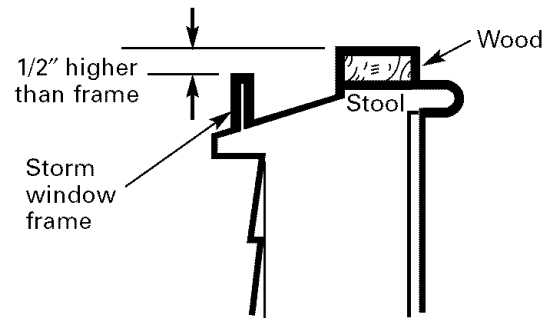

# Installation Instructions

## 3 REMOVE THE AIR CONDITIONER FROM THE CASE

- A** Remove the 2 shipping screws from the back of the case.
- B** Remove the 2 screws on each side of the case. Keep these for later use.

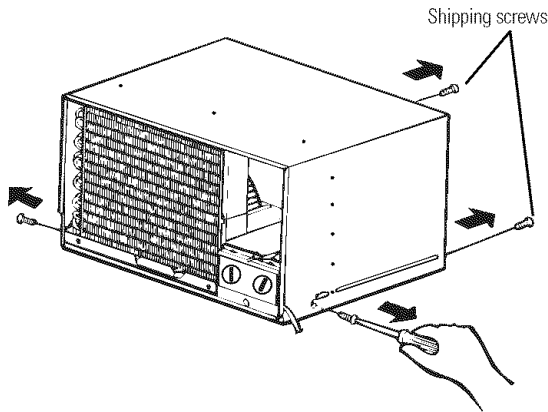

- C** Slide the air conditioner from the case by gripping the base pan handle and pulling forward while bracing the case.

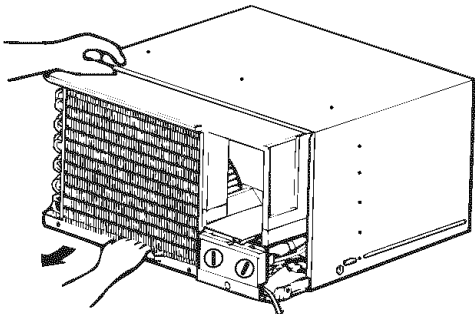

## 4 PREPARE THE WINDOW AND THE CASE

- A** Cut the window sash seal to the proper length. Peel off the backing and attach the seal to the underside of the window sash.

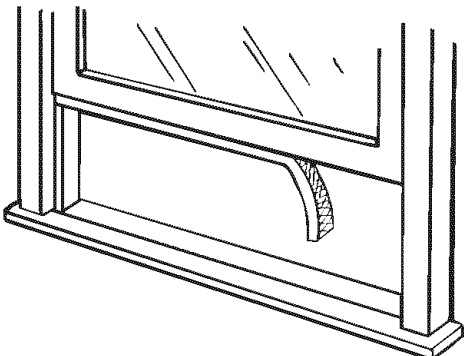

## 4 PREPARE THE WINDOW AND THE CASE (CONT.)

- B** Carefully insert the plastic frame guides into the bottom of the case on each side.

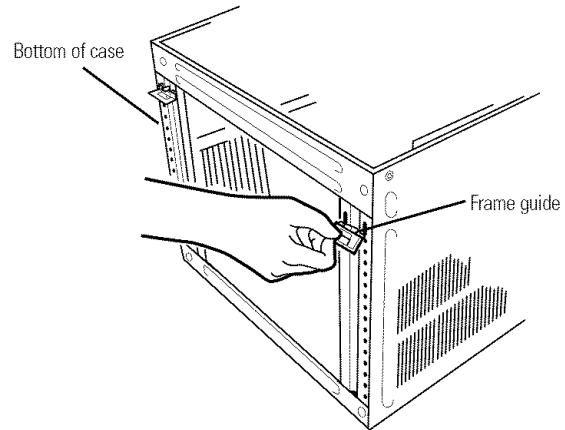

- C** Remove the backing from the top mounting rail seal strip and attach it to the bottom of the top mounting rail.

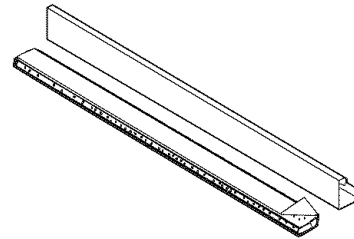

- D** Install the top mounting rail with 3 type A screws on the inside of the case. Insert the frames for the accordion panels into the top mounting rail and the frame guides. Attach the accordion panels to the side of the case using 5 type A screws on each side.

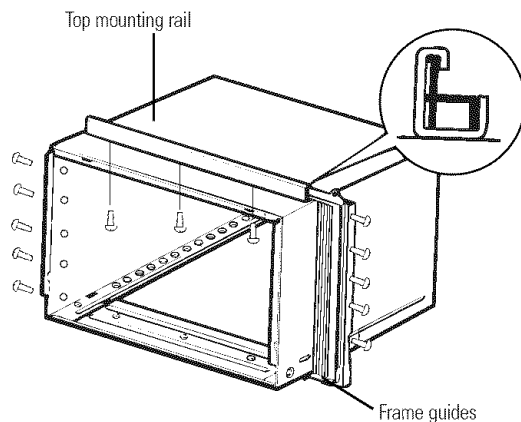

# Installation Instructions

## 5 PREPARE THE WINDOW

- A** Loosely attach the sill brackets to the support brackets using the 2 carriage bolts and 2 lock nuts.

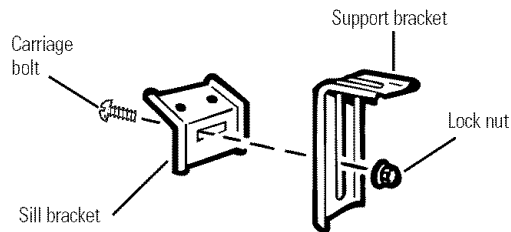

- B** Open the window and mark the centerline of the window stool. Measure and mark 11" to the left and right of the centerline.

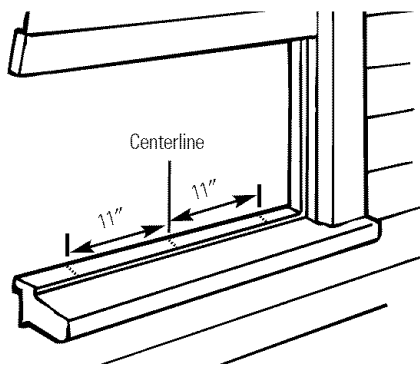

## 6 INSTALL THE CASE IN THE WINDOW

- A** Align the inside edge of the sill brackets with the 11" marks from the centerline and attach them to the window sill using 2 type B screws on each side.
- B** Carefully place the case on the window stool aligning the center front on the bottom with the centerline marked on the window stool. Close the window, making sure the window sash is behind the top mounting rail.
- C** Using the larger diameter hole in the case, attach the brackets to the case using two type D screws and 2 lock nuts on each side.

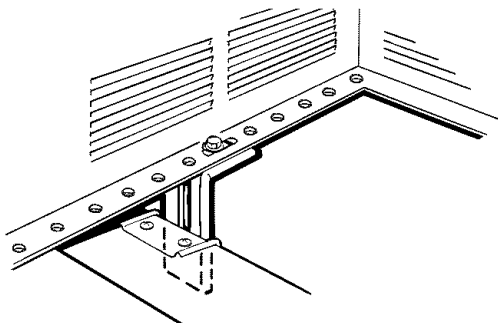

## 6 INSTALL THE CASE IN THE WINDOW (CONT.)

- D** Adjust the carriage bolts and the lock nuts in each support so that the case is installed with a slight tilt to the outside. Use a level; about 1/3 bubble will be the correct case slant to the outside. Tighten the bolts.

**CAUTION:** DO NOT drill a hole in the base pan. The unit is designed to operate with approximately 1/2" of water in the base pan.

- E** Secure the case to the window stool by using 3 type B screws.

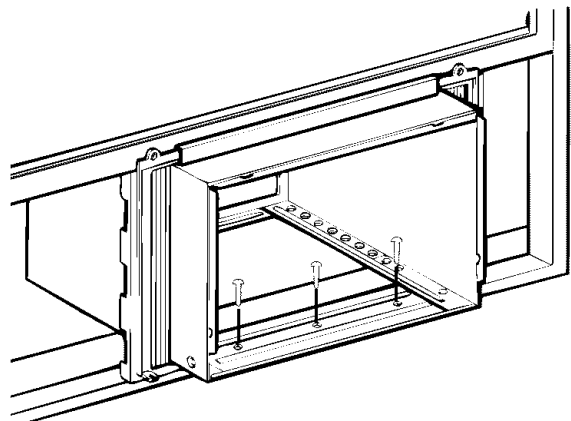

- F** Pull the accordion panels to each window sash track. Attach them on each side to the window sash and the window stool using 4 type C screws.

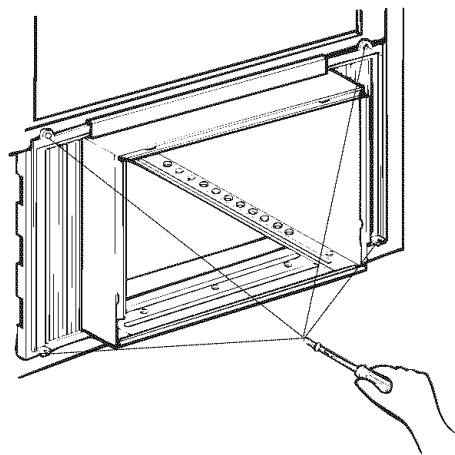

# Installation Instructions

## 7 INSTALL A SUPPORT BRACKET AND THE FOAM TOP WINDOW GASKET

- A** Attach a support bracket with a Type C screw.

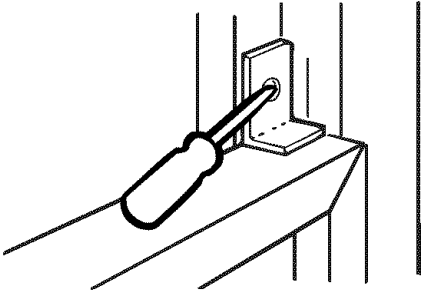

- B** Cut the foam top window gasket to the window width.
- C** Stuff the foam between the glass and the window to prevent air and insects from getting into the room.

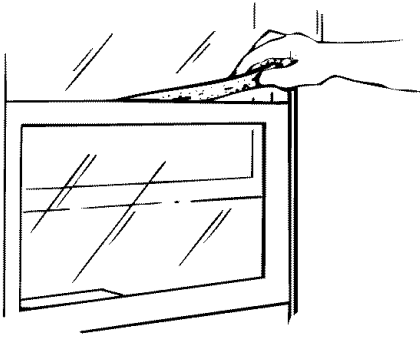

## 8 INSTALL THE AIR CONDITIONER IN THE CASE

- A** Slide the air conditioner into the case. Reinstall the 2 screws removed earlier on each side of the case.
- B** Before installing the front grille, pull out the vent control lever located above the unit control knobs, as shown.

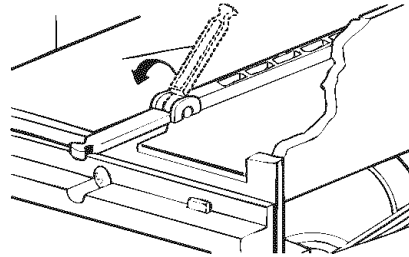

- C** Attach the front grille to the case by inserting the tabs on the grille into the slots on the front of the case. Push the grille in until it snaps into place.

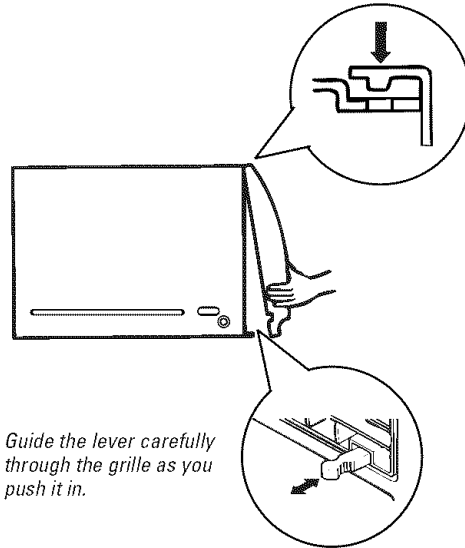

*Guide the lever carefully through the grille as you push it in.*

- D** Lift the inlet grille and secure the front frame with a type A screw through the front grille. Lower the inlet grille back into place.

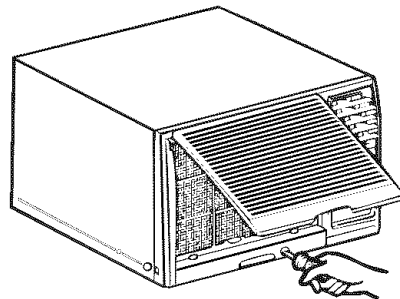



## Troubleshooting Tips

Save time and money! Review the chart below first and you may not need to call for service.

Problem	Possible Causes	What To Do
<b>Air conditioner does not start</b>	The air conditioner is unplugged	<ul style="list-style-type: none"> <li>• Make sure the air conditioner plug is pushed completely into the outlet.</li> </ul>
	The fuse is blown/circuit breaker is tripped	<ul style="list-style-type: none"> <li>• Check the house fuse/circuit breaker box and replace the fuse or reset the breaker.</li> </ul>
	Power failure	<ul style="list-style-type: none"> <li>• The unit will automatically re-start in the settings last used after the power is restored.</li> <li>• There is a protective time delay (approximately 3 minutes) to prevent tripping of the compressor overload. For this reason, the unit may not start normal cooling or heating for 3 minutes after it is turned back on.</li> </ul>
	The current interrupter device is tripped	<ul style="list-style-type: none"> <li>• Press the <b>RESET</b> button located on the power cord plug.</li> <li>• If the <b>RESET</b> button will not stay engaged, discontinue use of the air conditioner and contact a qualified service technician.</li> </ul>
<b>Air conditioner freezing up</b>	Ice blocks the air flow and stops the air conditioner from cooling the room	<ul style="list-style-type: none"> <li>• Set the mode control at <b>FAN</b> or <b>HIGH COOL</b> with the temp control at a warmer setting.</li> </ul>
<b>Air conditioner does not cool as it should</b>	Airflow is restricted	<ul style="list-style-type: none"> <li>• Make sure there are no curtains, blinds or furniture blocking the front of the air conditioner.</li> </ul>
	The temp control may not be set correctly	<ul style="list-style-type: none"> <li>• Turn the temperature knob clockwise as far as possible.</li> </ul>
	The air filter is dirty	<ul style="list-style-type: none"> <li>• Clean the filter at least every 30 days. See the <i>Operating Instructions</i> section.</li> </ul>
	The room may have been hot	<ul style="list-style-type: none"> <li>• When the air conditioner is first turned on you need to allow time for the room to cool down.</li> </ul>
	Cold air is escaping	<ul style="list-style-type: none"> <li>• Check for open furnace floor registers and cold air returns.</li> <li>• Set the air conditioner's vent to the closed position.</li> </ul>
	Cooling coils have iced up	<ul style="list-style-type: none"> <li>• See "<b>Air conditioner freezing up</b>" below.</li> </ul>
<b>Air conditioner does not warm as it should</b>	Airflow is restricted	<ul style="list-style-type: none"> <li>• Make sure there are no curtains, blinds or furniture blocking the front of the air conditioner.</li> </ul>
	The temp control may not be set low enough	<ul style="list-style-type: none"> <li>• Turn the knob counterclockwise as far as possible. The lowest setting provides maximum warming.</li> </ul>
	The air filter is dirty	<ul style="list-style-type: none"> <li>• Clean the filter at least every 30 days. See the <i>Operating Instructions</i> section.</li> </ul>
	The room may have been cold	<ul style="list-style-type: none"> <li>• When the air conditioner is first turned on, you need to allow time for the room to warm up.</li> </ul>
	Warm air is escaping	<ul style="list-style-type: none"> <li>• Check for open furnace floor registers and cold air returns.</li> </ul>

## Before you call for service...



### Troubleshooting Tips

<b>Problem</b>	<b>Possible Causes</b>	<b>What To Do</b>
<b>Water drips outside</b>	Excessively hot and humid weather	<ul style="list-style-type: none"> <li>• This is normal.</li> </ul>
<b>Water drips indoors</b>	The air conditioner is not tilted to the outside	<ul style="list-style-type: none"> <li>• For proper water disposal, make sure the air conditioner slants slightly from the case front to the rear.</li> </ul>
<b>Water collects in base pan</b>	Moisture is removed from indoor air and drains into rear of a cabinet where a fan blows it against the outdoor condenser coil	<ul style="list-style-type: none"> <li>• This is normal for a short period in areas with little humidity; normal for a longer period in very humid areas.</li> </ul>

### **Normal Operating Sounds**

- You may hear a pinging noise caused by water being picked up and thrown against the condenser on rainy days or when the humidity is high. This design feature helps remove moisture and improve efficiency.
- You may hear the thermostat click when the compressor cycles on and off.
- Water will collect in the base pan during high humidity or on rainy days. The water may overflow and drip from the outdoor side of the unit.
- The fan may run even when the compressor does not.

**Safety Instructions**

**Operating Instructions**

**Installation Instructions**

**Troubleshooting Tips**

**Consumer Support**

<b>Consumer Support</b>	<b>Troubleshooting Tips</b>	<b>Installation Instructions</b>	<b>Operating Instructions</b>	<b>Safety Instructions</b>
-------------------------	-----------------------------	----------------------------------	-------------------------------	----------------------------

**Notes.**

---



## GE Service Protection Plus™

GE, a name recognized worldwide for quality and dependability, offers you Service Protection Plus™—comprehensive protection on all your appliances—**No Matter What Brand!**

**Benefits Include:**

- Backed by GE
- All brands covered
- Unlimited service calls
- All parts and labor costs included
- No out-of-pocket expenses
- No hidden deductibles
- One 800 number to call

***We'll Cover Any Appliance.  
Anywhere. Anytime.\****

You will be completely satisfied with our service protection or you may request your money back on the remaining value of your contract. No questions asked. It's that simple.

Protect your refrigerator, dishwasher, washer and dryer, range, TV, VCR and much more—**any brand!** Plus there's no extra charge for emergency service and low monthly financing is available. Even icemaker coverage and food spoilage protection is offered. You can rest easy, knowing that all your valuable household products are protected against expensive repairs.

Place your confidence in GE and call us in the U.S. toll-free at **800.626.2224** for more information.

\*All brands covered, up to 20 years old, in the continental U.S.



Please place in envelope and mail to:

***General Electric Company***  
**Warranty Registration Department**  
**P.O. Box 32150**  
**Louisville, KY 40232-2150**

# Consumer Product Ownership Registration

Dear Customer:

Thank you for purchasing our product and thank you for placing your confidence in us. We are proud to have you as a customer!

Follow these three steps to protect your new appliance investment:

# 1

Complete and mail your **Consumer Product Ownership Registration** today. Have the peace of mind of knowing we can contact you in the unlikely event of a safety modification.

# 2

After mailing the registration below, store this document in a safe place. It contains information you will need should you require service. Our service number is 800.GE.CARES (800.432.2737).

# 3

Read your Owner's Manual carefully. It will help you operate your new appliance properly.

Model Number

Serial Number



**Important: If you did not get a registration card with your product, detach and return the form below to ensure that your product is registered, or register online at ge.com.**

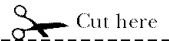

# Consumer Product Ownership Registration



Model Number

Serial Number



Mr.  Ms.  Mrs.  Miss

First Name

Last Name

Street Address

Apt. #

E-mail Address\*

City

State

Zip Code

Date Placed In Use  
Month

Day

Year

Phone Number  -  -



**GE Consumer & Industrial Appliances**  
General Electric Company  
Louisville, KY 40225  
ge.com

\* Please provide your e-mail address to receive, via e-mail, discounts, special offers and other important communications from GE Appliances (GEA).  
 Check here if you do not want to receive communications from GEA's carefully selected partners.

**FAILURE TO COMPLETE AND RETURN THIS CARD DOES NOT DIMINISH YOUR WARRANTY RIGHTS.**

For information about GEA's privacy and data usage policy, go to ge.com and click on "Privacy Policy" or call 800.626.2224.

# GE Air Conditioner Warranty.

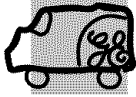

All warranty service provided by our Factory Service Centers, or an authorized Customer Care® technician. To schedule service, on-line, 24 hours a day, visit us at [ge.com](http://ge.com), or call 800.GE.CARES (800.432.2737). Please have serial number and model number available when calling for service.

Staple your receipt here.  
Proof of the original purchase date is needed to obtain service under the warranty.

## For The Period Of: GE Will Replace:

### One Year

From the date of the original purchase

**Any part** of the air conditioner which fails due to a defect in materials or workmanship. During this **limited one-year warranty**, GE will also provide, **free of charge**, all labor and related service to replace the defective part.

### Five Years

From the date of the original purchase

**Any part of the sealed refrigerating system** (the compressor, condenser, evaporator and all connecting tubing) which fails due to a defect in materials or workmanship. During this **four-year limited additional warranty**, GE will also provide, **free of charge**, all labor and related service to replace the defective part.

## What Is Not Covered:

- Service trips to your home to teach you how to use the product.
- Improper installation, delivery or maintenance. If you have an installation problem, or if the air conditioner is of improper cooling capacity for the intended use, contact your dealer or installer. You are responsible for providing adequate electrical connecting facilities.
- Failure of the product resulting from modifications to the product or due to unreasonable use including failure to provide reasonable and necessary maintenance.
- In commercial locations labor necessary to move the unit to a location where it is accessible for service by an individual technician.
- Replacement of house fuses or resetting of circuit breakers.
- Failure due to corrosion on models not corrosion-protected.
- Damage to the product caused by improper power supply voltage, accident, fire, floods or acts of God.
- Incidental or consequential damage caused by possible defects with this air conditioner.
- Damage caused after delivery.
- Product not accessible to provide required service.

**EXCLUSION OF IMPLIED WARRANTIES—Your sole and exclusive remedy is product repair as provided in this Limited Warranty. Any implied warranties, including the implied warranties of merchantability or fitness for a particular purpose, are limited to one year or the shortest period allowed by law.**

This warranty is extended to the original purchaser and any succeeding owner for products purchased for home use within the USA. If the product is located in an area where service by a GE Authorized Servicer is not available, you may be responsible for a trip charge or you may be required to bring the product to an Authorized GE Service location for service. In Alaska, the warranty excludes the cost of shipping or service calls to your home.

Some states do not allow the exclusion or limitation of incidental or consequential damages. This warranty gives you specific legal rights, and you may also have other rights which vary from state to state. To know what your legal rights are, consult your local or state consumer affairs office or your state's Attorney General.

Warrantor: General Electric Company, Louisville, KY 40225

## Consumer Support.

---



### *GE Appliances Website*

**ge.com**

Have a question or need assistance with your appliance? Try the GE Appliances Website 24 hours a day, any day of the year! For greater convenience and faster service, you can now download Owner's Manuals, order parts, catalogs, or even schedule service on-line. You can also "Ask Our Team of Experts™" your questions, and so much more...

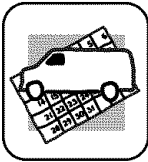

### *Schedule Service*

**ge.com**

Expert GE repair service is only one step away from your door. Get on-line and schedule your service at your convenience 24 hours any day of the year! Or call 800.GE.CARES (800.432.2737) during normal business hours.

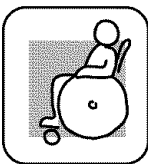

### *Real Life Design Studio*

**ge.com**

GE supports the Universal Design concept—products, services and environments that can be used by people of all ages, sizes and capabilities. We recognize the need to design for a wide range of physical and mental abilities and impairments. For details of GE's Universal Design applications, including kitchen design ideas for people with disabilities, check out our Website today. For the hearing impaired, please call 800.TDD.GEAC (800.833.4322).



### *Extended Warranties*

**ge.com**

Purchase a GE extended warranty and learn about special discounts that are available while your warranty is still in effect. You can purchase it on-line anytime, or call 800.626.2224 during normal business hours. GE Consumer Home Services will still be there after your warranty expires.

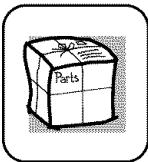

### *Parts and Accessories*

**ge.com**

Individuals qualified to service their own appliances can have parts or accessories sent directly to their homes (VISA, MasterCard and Discover cards are accepted). Order on-line today, 24 hours every day or by phone at 800.626.2002 during normal business hours.

***Instructions contained in this manual cover procedures to be performed by any user. Other servicing generally should be referred to qualified service personnel. Caution must be exercised, since improper servicing may cause unsafe operation.***



### *Contact Us*

**ge.com**

If you are not satisfied with the service you receive from GE, contact us on our Website with all the details including your phone number, or write to: General Manager, Customer Relations  
GE Appliances, Appliance Park  
Louisville, KY 40225



### *Register Your Appliance*

**ge.com**

Register your new appliance on-line—at your convenience! Timely product registration will allow for enhanced communication and prompt service under the terms of your warranty, should the need arise. You may also mail in the pre-printed registration card included in the packing material.