

Owner's Manual

36" Stainless Steel
Gas Cooktop

ZGU375LS

ZGU375NS



Monogram®

Introduction

Your new Monogram cooktop makes an eloquent statement of style, convenience and kitchen planning flexibility. Whether you chose it for its purity of design, assiduous attention to detail—or for both of these reasons—you’ll find that your Monogram cooktop’s superior blend of form and function will delight you for years to come.

Your Monogram cooktop was designed to provide the flexibility to blend in with your kitchen cabinetry. Its sleek design can be beautifully integrated into the kitchen.

The information on the following pages will help you operate and maintain your cooktop properly.

Contents

Care and Cleaning	Using Your Cooktop
Burner Caps 15	Cookware12
Burner Grates 15	Dual-Flame Burners11
Burner Sub-assemblies14	Electric Ignition10
Control Knobs 13	Features 9
Sealed Burner Assemblies 13	Flame Size 10
Stainless Steel Surfaces 13	LP Gas9
Consumer Services	Optional Griddle Accessory9
Before You Call for Service 16	Wok Cooking12
Important Phone Numbers 17	
Model and Serial Number 4	
Product Registration19, 20	
Safety Instructions 2, 3, 5–8	
Warranty 18	

WARNING: If the information in this manual is not followed exactly, a fire or explosion may result causing property damage, personal injury or death.

- Do not store or use gasoline or other flammable vapors and liquids in the vicinity of this or any other appliance.
- **WHAT TO DO IF YOU SMELL GAS**
 - Do not try to light any appliance.
 - Do not touch any electrical switch; do not use any phone in your building.
 - Immediately call your gas supplier from a neighbor’s phone. Follow the gas supplier’s instructions.
 - If you cannot reach your gas supplier, call the fire department.
- Installation and service must be performed by a qualified installer, service agency or the gas supplier.



AVERTISSEMENT : Si les informations de ce manuel ne sont pas suivies à la lettre, un incendie ou une explosion peut résulter et causer des dommages matériels, des blessures ou la mort.

— Ne stockez pas ou n'utilisez pas de l'essence ou d'autres vapeurs ou liquides inflammables à proximité de cet appareil électrique ou de tout autre.

— **QUE FAIRE SI VOUS SENTEZ DU GAZ**

- N'essayez pas d'allumer un appareil quelconque.
 - Ne touchez aux interrupteurs électriques ; n'utilisez pas les téléphones de votre immeuble.
 - Appelez immédiatement votre fournisseur de gaz à partir du téléphone d'un voisin. Suivez les instructions du fournisseur de gaz.
 - Si vous ne pouvez pas contacter votre fournisseur de gaz, appelez les pompiers.
- L'installation et l'entretien doivent être effectués par un installateur qualifié, une agence d'entretien ou le fournisseur du gaz.



Consumer Information

Gas Cooktop

Before using your cooktop

Read this manual carefully. It is intended to help you operate and maintain your new cooktop properly.

Keep it handy for answers to your questions.

If you don't understand something or need more help, call:

GE Answer Center®

800.626.2000

24 hours a day, 7 days a week

OR

Visit our Website at: **ge.com**

Write down the model & serial numbers

You'll find them on a label located on the underside of the cooktop.

These numbers are also on the Consumer Product Ownership Registration Card included in this manual.

Before sending in this card, please write these numbers here:

Model Number

Serial Number

Use these numbers in any correspondence or service calls concerning your cooktop.

If you received a damaged cooktop

Immediately contact the dealer (or builder) that sold you the cooktop.

Save time & money

Before you request service, check the "Before you call for service" section in the back of this manual.

It lists causes of minor operating problems that you can correct yourself.

If you need service

To obtain service, see the Consumer Services page in the back of this manual.

We're proud of our service and want you to be pleased. If for some reason you are not happy with the service you receive, here are some steps to follow for further help.

FIRST, contact the people who serviced your appliance. Explain why you are not pleased. In most cases, this will solve the problem.

NEXT, if you are still not pleased, write all the details—including your phone number—to:

Manager, Customer Relations
GE Appliances
Appliance Park
Louisville, KY 40225

IMPORTANT SAFETY INSTRUCTIONS

SAFETY PRECAUTIONS

IMPORTANT SAFETY NOTICE:

- **The California Safe Drinking Water and Toxic Enforcement Act** requires the Governor of California to publish a list of substances known to the state to cause cancer, birth defects or other reproductive harm, and requires businesses to warn customers of potential exposure to such substances.
- **Gas appliances can cause minor exposure to four of these substances**, namely benzene, carbon monoxide, formaldehyde and soot, caused primarily by the incomplete combustion of natural gas or LP fuels. Properly adjusted burners, indicated by a bluish rather than a yellow flame, will minimize incomplete combustion. Exposure to these substances can be minimized further by venting with an open window or using the ventilation fan.
- **When you get your cooktop, have the installer show you the location of the gas shut-off valve and how to shut it off if necessary.**
- **Have your cooktop installed and properly grounded by a qualified installer**, in accordance with the installation instructions. Any adjustment and service should be performed only by qualified gas range installers or service technicians.
- **Plug your cooktop into a 120-volt grounded outlet only.** Do not remove the round grounding prong from the plug. If in doubt about the grounding of the home electrical system, it is your personal responsibility and obligation to have an ungrounded outlet replaced with a properly-grounded 3-prong outlet in accordance with the National Electrical Code. Do not use an extension cord with this appliance.
- **Be sure all packing materials are removed from the cooktop** before operating it, to prevent fire or smoke damage should the packing material ignite.
- **Be sure your cooktop is correctly adjusted by a qualified service technician or installer** for the type of gas (natural or LP) which is to be used.
- **Do not attempt to repair or replace any part of your cooktop unless it is specifically recommended in this manual.** All other servicing should be referred to a qualified technician.
- **Do not leave children alone or unattended where a cooktop is hot or in operation.** They could be seriously burned.
- **CAUTION:** Items of interest to children should not be stored in cabinets above a cooktop—children climbing on the cooktop to reach items could be seriously injured.
- **Clean the cooktop with caution.** If a wet sponge or cloth is used to wipe spills on a hot cooktop, be careful to avoid steam burns.
- **Do not clean the cooktop with flammable or volatile cleaning fluids.**
- **Do not clean the cooktop when the appliance is in use.**
- **Avoid scratching the cooktop** with sharp instruments, or with rings and other jewelry.
- **Let the burner grates and other surfaces cool before touching them or leaving them where children can reach them.**
- **Never use the cooktop as a cutting board.**
- **Never wear loose-fitting or hanging garments while using the appliance.** Be careful when reaching for items stored in cabinets over the cooktop. Flammable material could be ignited if brought in contact with flame or hot surfaces and may cause severe burns.
- **For your safety, never use your appliance for warming or heating the room.**
- **Do not use water on grease fires. Never pick up a flaming pan.** Turn the controls off. Smother a flaming pan on a surface burner by covering the pan completely with a well-fitting lid, cookie sheet or flat tray. Use a multi-purpose dry chemical or foam-type fire extinguisher. Flaming grease outside a pan can be put out by covering it with baking soda or, if available, by using a multi-purpose dry chemical or foam-type fire extinguisher.
- **Do not store flammable materials near the cooktop.** Do not store or use gasoline or other flammable vapors and liquids in the vicinity of this or any other appliance.
- **Do not let cooking grease or other flammable materials accumulate on or near the cooktop.**
- **Never leave surface burners unattended at high flame settings.** Boilovers cause smoking and greasy spillovers that may catch on fire.
- **Adjust surface burner flame size so it does not extend beyond the edge of the cookware.** Excessive flame is hazardous.

IMPORTANT SAFETY INSTRUCTIONS

- **Use only dry pot holders**—moist or damp pot holders on hot surfaces may result in burns from steam. Do not let pot holders come near open flames when lifting cookware. Do not use a towel or other bulky cloth in place of a pot holder.
- **To minimize the possibility of burns**, ignition of flammable materials and spillage, turn cookware handles toward the side or center of the cooktop without extending over adjacent burner or vent area.
- **Always turn the surface burners to off before removing the cookware.**
- **Foods for frying should be as dry as possible.** Frost on frozen foods or moisture on fresh foods can cause hot fat to bubble up and over the sides of the pan.
- **Use least possible amount of fat for effective shallow or deep fat frying.** Filling the pan too full of fat can cause spillovers when food is added.
- **Carefully watch foods being fried at high flame setting.**
- **If a combination of oils or fats will be used in frying**, stir together before heating, or as fats melt slowly.
- **Always heat fat slowly**, and watch as it heats.
- **Use a deep fat thermometer whenever possible** to prevent overheating fat beyond the smoking point.
- **Use proper pan size**—avoid pans that are unstable or easily tipped. Select cookware having flat bottoms large enough to properly contain food and avoid boilovers and spillovers, and large enough to cover burner grate. This will both save cleaning time and prevent hazardous accumulations of food, since heavy spattering or spillovers left on cooktop can ignite. Use pans with handles that can be easily grasped and remain cool.
- **Keep all plastics away from burners.**
- **To avoid the possibility of a burn, always be certain that the controls for all burners are at the off position and all grates are cool before attempting to remove a grate.**
- **If the cooktop is located near a window**, do not use long curtains which could blow over the burners and create a fire hazard.
- **If you smell gas**, turn off the gas to the cooktop and call a qualified service technician. Never use an open flame to locate a leak.
- **Do not cover or block the area around the cooktop knobs.** This area must be kept clear for proper ventilation and burner performance.
- **Cook meat and poultry thoroughly**—meat to at least an INTERNAL temperature of 160°F. and poultry to at least an INTERNAL temperature of 180°F. Cooking to these temperatures usually protects against foodborne illness.
- **When using a wok on the cooking surface**, always use the provided metal ring which is placed over the center burner grate to support the wok.
- **Do not flame foods on the cooktop. If you do flame foods under the hood**, turn the fan on.

SAVE THESE INSTRUCTIONS

INSTRUCTIONS DE SÉCURITÉ IMPORTANTES

PRÉCAUTIONS DE SÉCURITÉ

AVIS IMPORTANT DE SÉCURITÉ :

- La loi de l'état de Californie sur l'eau potable sécurisée et l'application des lois sur les produits toxiques exige que le Gouverneur de Californie publie une liste de substances qui, selon les connaissances de l'état, causent le cancer, les maladies congénitales ou autre lésion reproductrice, et exige que les entreprises avertissent leurs clients de leur exposition potentielle à de telles substances.

- Les appareils à gaz peuvent causer une exposition mineure à quatre de ces substances, soit le benzène, le monoxyde de carbone, le formaldéhyde et la suie, surtout à cause de la combustion incomplète du gaz naturel ou des carburants PL.

Des brûleurs correctement ajustés, ce qui est indiqué par des flammes bleuâtres plutôt que jaunes, réduiront au minimum la combustion incomplète. L'exposition à ces substances peut être réduite davantage en aérant avec une fenêtre ouverte ou en utilisant le ventilateur d'aération.

- Lorsque vous recevez votre cuisinière, demandez à l'installateur de vous montrer l'emplacement de la soupape d'arrêt et la façon de la fermer en cas de besoin.
- Demandez à un installateur qualifié d'installer et de mettre à la terre correctement votre cuisinière, conformément aux instructions d'installation. Tout ajustement ou entretien doit être effectué seulement par des installateurs de cuisinière à gaz qualifiés ou des techniciens de service.
- Branchez votre cuisinière seulement sur une prise de 120 volts mise à la terre. Ne retirez pas la broche ronde de mise à la terre de la prise. En cas de doute concernant la mise à la terre du système électrique de la résidence, vous assumez la responsabilité et l'obligation personnelles de faire remplacer toute prise non mise à la terre par une prise à trois broches correctement mise à la terre conformément au Code national de l'électricité. N'utilisez pas de rallonge de câble avec cet appareil.
- Assurez-vous que tous les matériaux d'emballage sont retirés de la cuisinière avant de la mettre en marche, pour empêcher les dommages d'incendie et de fumée au cas où le matériau d'emballage s'enflammerait.

- Assurez-vous que la cuisinière est ajustée correctement par un technicien de service ou un installateur qualifié en fonction du type de gaz (naturel ou PL) qui sera utilisé.

- N'essayez pas de réparer ou de remplacer toute pièce de la cuisinière sauf si cela est spécifiquement recommandé dans ce manuel. Toutes les autres actions de service doivent être référées à un technicien qualifié.

- Ne laissez pas les enfants seuls ou non surveillés lorsqu'une cuisinière est chaude ou en marche. Ils pourraient être brûlés grièvement.

- **ATTENTION :** Les articles suscitant l'intérêt des enfants ne doivent pas être rangés dans les armoires au-dessus de la cuisinière—les enfants grimant sur la cuisinière pour saisir ces articles pourraient être grièvement blessés.

- Nettoyez la cuisinière avec précaution. Si une éponge ou un chiffon mouillé est utilisé pour essuyer les renversements sur une cuisinière chaude, faites attention d'éviter les brûlures causées par la vapeur.

- Ne nettoyez pas la cuisinière avec des nettoyants inflammables ou volatils.

- Ne nettoyez pas la cuisinière lorsqu'elle est en marche.

- Évitez de rayer la cuisinière avec des instruments pointus ou avec des bagues ou d'autres bijoux.

- Laissez refroidir les grilles des brûleurs et les autres surfaces avant de les toucher ou de les laisser là où les enfants peuvent les atteindre.

- N'utilisez jamais la cuisinière comme planche à découper.

- Ne portez jamais de vêtements lâches ou amples lorsque vous utilisez cet appareil. Faites attention pour saisir des articles rangés dans les armoires au-dessus de la cuisinière. La matière inflammable peut s'enflammer si elle entre en contact avec les flammes ou les surfaces chaudes et peut causer des brûlures graves.

- Pour votre sécurité, n'utilisez jamais votre appareil pour chauffer ou réchauffer la pièce.

INSTRUCTIONS DE SÉCURITÉ IMPORTANTES

- **N'utilisez pas de l'eau sur les incendies de graisse. Ne saisissez jamais une poêle enflammée.** Arrêtez les contrôles. Éteignez les flammes d'une poêle placées sur un brûleur de surface en la recouvrant entièrement d'un couvercle bien ajusté, d'un plateau à gâteau ou d'un plateau plat. Utilisez un extincteur à produit chimique sec multi-usages ou du type à mousse.

Le graisse enflammée à l'extérieur d'une poêle peut être éteinte en la couvrant de bicarbonate de soude ou, s'il est disponible, en utilisant un extincteur à produit chimique sec multi-usages ou du type à mousse.

- **Ne stockez pas de matière inflammable près de la cuisinière.** Ne stockez pas et n'utilisez pas d'essence ou d'autres vapeurs ou liquides inflammables à proximité de cet appareil ou de tout autre.
- **Ne laissez pas la graisse de cuisson ou autre matière inflammable s'accumuler sur ou près de la cuisinière.**
- **Ne laissez jamais les brûleurs de surface sans surveillance lorsqu'ils sont réglés pour des flammes hautes.** Les débordements excessifs causent de la fumée et des renversements graisseux qui pourraient s'enflammer.
- **Ajustez la taille des flammes des brûleurs de surface pour qu'elles ne dépassent pas du bord du conteneur.** Les flammes excessives sont dangereuses.
- **Utilisez seulement des gants secs pour saisir les plats**—les gants humides ou mouillés placés sur des surfaces chaudes peuvent causer des brûlures dues à la vapeur. Ne mettez pas les gants près des flammes vives pour soulever les plats. N'utilisez pas de serviette ou autre chiffon encombrant au lieu des gants de plat.
- **Pour réduire au minimum la possibilité de brûlures, d'inflammation de matière inflammable et de renversement, tournez les poignées des plats vers le côté ou le centre de la cuisinière, sans les placer au-dessus d'un brûleur adjacent ou une zone d'aération.**
- **Arrêtez toujours les brûleurs de surface avant de retirer les plats.**
- **Les aliments à frire doivent être aussi secs que possible.** Le gel des aliments congelés ou l'humidité des aliments frais peut causer le bouillonnement des matières grasses chaudes et leur déversement sur le côté de la poêle.
- **Utiliser la quantité de graisse la plus faible possible pour la friture à la poêle ou à la friteuse.** Si l'ustensile est trop rempli de graisse, celle-ci peut déborder lorsque les aliments sont ajoutés.
- **Observez avec soin les aliments frits sur flammes hautes.**
- **Si un mélange d'huile et de matières grasses va être utilisé pour la friture, mélangez avant le chauffage ou à mesure que les matières grasses fondent lentement.**
- **Réchauffez toujours lentement les matières grasses** et observez leur réchauffement.
- **Utilisez un thermomètre de friteuse lorsque cela est possible** possible pour empêcher de surchauffer les matières grasses au-delà de leur point de fumée.
- **Utiliser des poêles de taille appropriée**— évitez les poêles qui sont instables ou qui peuvent basculer facilement. Sélectionnez des ustensiles de cuisine avec des fonds plats, suffisamment grands pour pouvoir correctement contenir les aliments et éviter les débordements et les déversements, et suffisamment grands pour recouvrir les grilles des brûleurs. Cela réduira le temps de nettoyage et empêchera les accumulations dangereuses d'aliments, étant donné que les éclaboussures ou les déversements importants laissés sur la cuisinière peuvent s'enflammer. Utilisez des poêles avec des poignées qui peuvent être facilement saisies et qui restent froides.
- **Eloignez tous les matériaux en plastique des brûleurs.**
- **Pour éviter les risques de brûlures, assurez-vous toujours que les contrôles des brûleurs sont à la position d'arrêt et toutes les grilles sont froides avant d'essayer de retirer une grille.**
- **Si la cuisinière est située près d'une fenêtre, n'utilisez pas de longs rideaux** qui pourraient être projetés au-dessus des brûleurs et constituer un risque d'incendie.
- **Si vous sentez du gaz, coupez l'arrivée du gaz à la cuisinière et appelez un technicien de service qualifié.** N'utilisez jamais de flamme vive pour rechercher les fuites.
- **Ne couvrez pas et ne bloquez pas la zone autour des boutons de la cuisinière.** Cette zone doit rester dégagée pour assurer une bonne ventilation et une bonne performance des brûleurs.
- **Cuisez la viande et la volaille complètement**— la viande à une température INTERNE d'au moins 160°F, et la volaille à une température INTERNE d'au moins 180°F. La cuisson à ces températures protège en général contre les maladies causées par les aliments contaminés.
- **Lorsque vous utilisez un wok sur la surface de cuisson, utilisez toujours l'anneau métallique fourni qui est placé sur la grille du brûleur central pour supporter le wok.**
- **Ne préparez pas des mets flambés sur la cuisinière.** Si vous préparez des mets flambés sous la hotte, mettez le ventilateur en marche.

CONSERVEZ CES INSTRUCTIONS

Features of Your Cooktop

Gas Cooktop

Design information

(Not all features are on all models. Appearance may vary.)

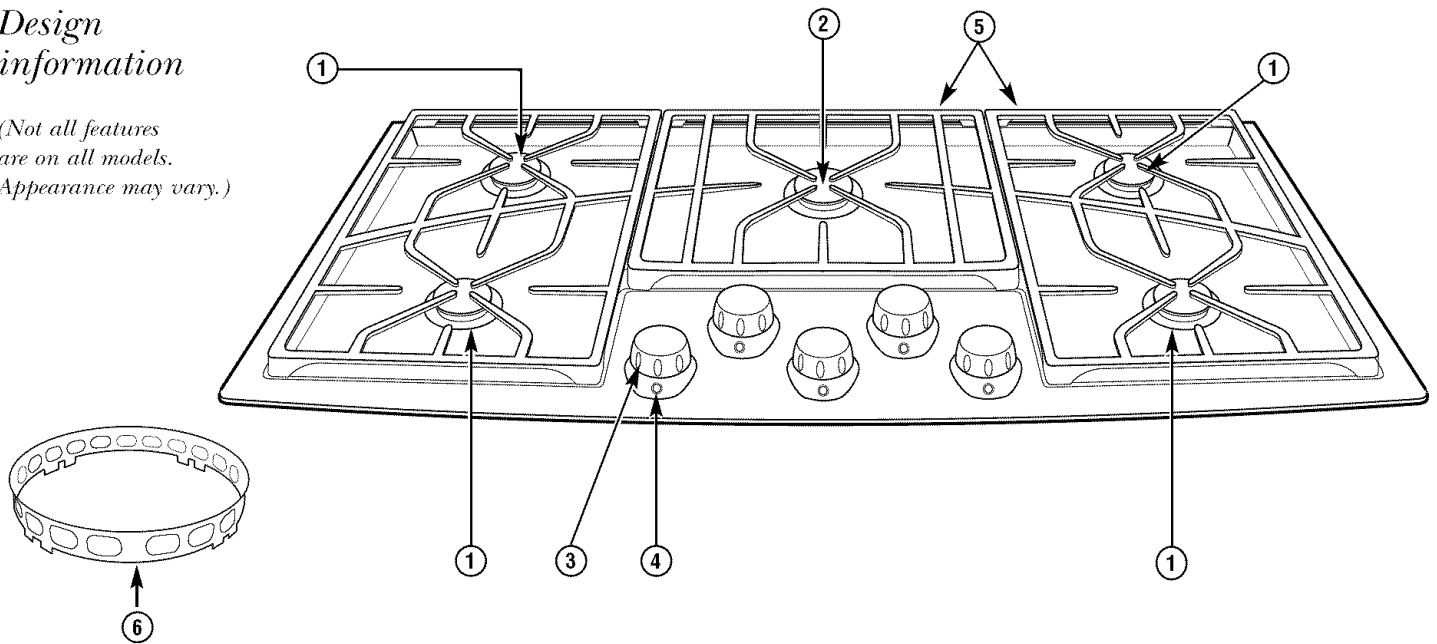

Feature Index	Page
1 Dual-Flame Spillproof Burners—High Output	10, 11, 13, 14
2 Dual-Flame Spillproof Burner—Maximum Output	10, 11, 13, 14
3 Tactile-touch Control Knobs (One For Each Surface Burner)	13
4 Burner “ON” Indicator Lamps (One On Each Control Knob)	10
5 Interlocking Grates	10, 15
6 Wok Ring Accessory (Supplied On Some Models)	12

Optional griddle accessory

A dual griddle is available that can be placed over the two right or left burners on your cooktop. Contact your local distributor or GE at 800.626.2002 and order part number **ZX375GRD**.

LP Gas

Cooktop model ZGU375NS is shipped from the factory set to operate only with Natural Gas. If you wish to use Liquefied Petroleum Gas, you must have cooktop model ZGU375LS.

Using Your Cooktop

Gas Cooktop

Electric ignition & relight

Your surface burners are lit by electric ignition, eliminating the need for standing pilot lights with constantly burning flames.

All five igniters make clicking sounds and spark even when only a single burner is being turned on. Do not touch any of the burners when the igniters are clicking.

The burners on this cooktop relight automatically if the flame goes out. This helps prevent the inconvenience of having to manually relight a burner.

Occasionally, the burners may spark if excess wind or draft blows the flame away from the burner's flame sensor.

All of the burner igniters spark while a burner is relighting.

In case of a power outage, you can light the surface burners on your cooktop with a match. Hold a lighted match to the burner, then turn the knob to the HIGH position. **Use extreme caution when lighting burners this way.**

Surface burners in use when an electrical power failure occurs will continue to operate normally.

To light a burner

Push the control knob down and turn it **counterclockwise** to the desired position from HI to LO or simmer (SIM).

After the burner ignites, turn the knob in either direction to adjust the flame size.

To turn a burner off, turn the knob clockwise, as far as it will go, to the OFF position.

- All of the burners can be used for both general cooking and simmering. The center burner is the maximum output burner for larger pans or fast boiling operations.
- Do not operate a burner for an extended period of time without cookware on the grate. The finish on the grate may chip without cookware to absorb the heat.
- Be sure the burners and grates are cool before you place your hand, a pot holder, cleaning cloths or other materials on them.
- For your convenience, the indicator lamp in the bezel for each knob verifies the burner is "ON".
- Be sure you turn the control knob to "OFF" when you finish cooking.

How to select flame size

Watch the flame, not the knob, as you reduce heat.

The flame size on a gas burner should match the cookware you are using.

FOR SAFE HANDLING OF COOKWARE, NEVER LET THE FLAME EXTEND UP THE SIDES OF THE COOKWARE. Any flame larger than the bottom of the cookware is wasted and only serves to heat the handle.

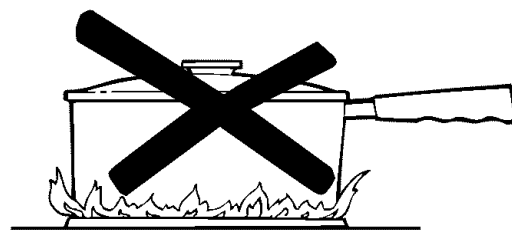

NOTE: The center maximum output burner has an extra large flame. Use 10" or larger diameter cookware when using high heat settings.

Dual-flame burners

All five burners on your cooktop have two rows of flames. These dual-flame burners have a simmer (lower) flame and a main (upper) flame.

When a burner is turned on, the simmer flame will always light and stay on.

Simmering: The simmer (SIM) setting will use only the lower flames. Use simmer (SIM) to melt chocolate, hold delicate sauces or for other foods requiring low simmer heat.

When holding some foods at serving temperature (such as mashed potatoes), it may be best to use the LO flame setting for a few minutes before turning the knob to simmer (SIM).

Primary Cooking: Settings from LO to HI will use both rows of flames. Use LO to HI for all purpose cooking.

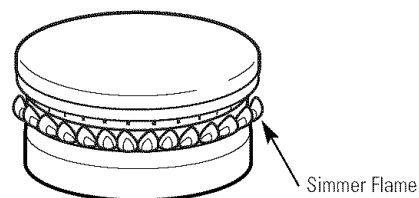

Simmer Burner

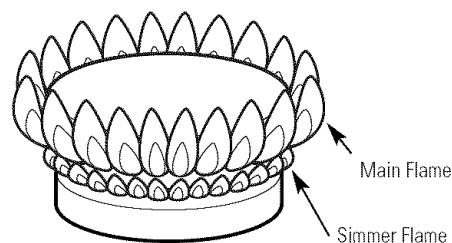

Main Burner

Using Your Cooktop

Gas Cooktop

Cookware

Aluminum: Medium-weight cookware is recommended because it heats quickly and evenly. Most foods brown evenly in an aluminum skillet. Use saucepans with tight-fitting lids for cooking with minimum amounts of water.

Cast Iron: If heated slowly, most skillets will give satisfactory results.

Enamelware: Under some conditions, the enamel of some cookware may melt. Follow cookware manufacturer's recommendations for cooking methods.

Glass: There are two types of glass cookware—those for oven use only and those for surface cooking (saucepans, coffee and teapots). Glass conducts heat very slowly.

Heatproof Glass-Ceramic: Can be used for either surface or oven cooking. It conducts heat very slowly and cools very slowly. Check cookware manufacturer's directions to be sure it can be used on gas cooktops.

Stainless Steel: This metal alone has poor heating properties, and is usually combined with copper, aluminum or other metals for improved heat distribution. Combination metal skillets generally work satisfactorily if they are used at medium heat as the manufacturer recommends.

Wok cooking

Use woks with a support ring (provided on some models) on the center burner only. Make sure that the support ring is securely locked onto the **center** grate fingers. Do not try to use round bottomed woks without a ring. You could be seriously burned if the wok tipped over.

Use a 12" or smaller diameter wok if the cooktop is installed adjacent to standard wall surfaces. If wall surfaces are constructed of or covered with non-combustible materials (such as masonry, ceramics, granite, stainless steel, etc.) a larger diameter wok may be used. Ensure that the wok is properly nested in the ring prior to cooking. The wok should be stable and the bottom of the wok should not touch the center grate when in the wok ring.

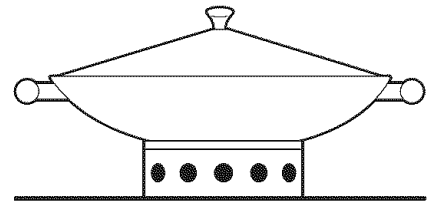

Care and Cleaning

Gas Cooktop

General information

Proper care and cleaning are important so your cooktop will give you efficient and satisfactory service. Follow these directions carefully in caring for it.

Some cooktop models are provided with cleaners. Follow the instructions on the containers.

Before cleaning any part of your cooktop, be sure all burners are off and cool. **DISCONNECT ELECTRICAL POWER TO THE COOKTOP** at the fuse box or circuit breaker panel, or pull the cooktop power plug, located beneath the cooktop and inside the cabinets.

Stainless steel surfaces

Do not use a steel wool pad; it will scratch the surface.

To clean the stainless steel surface, use warm sudsy water or a stainless steel cleaner or polish. Always wipe the surface in the direction of the grain. Follow the cleaner instructions for cleaning the stainless steel surface.

To inquire about purchasing stainless steel appliance cleaner or polish, or to find the location of a dealer nearest you, please call our toll-free number:

National Parts Center 1.800.626.2002
ge.com

Control knobs

The control knobs may be removed for easier cleaning.

To remove knob, pull it straight up.

The knobs have a tactile grip surface, but no special cleaning is required.

The knobs can be cleaned in a dishwasher or they may also be washed with soap and water. Make sure the insides of the knobs are dry before replacing.

Replace the knobs after cleaning.

NOTE: The knob stem is “D” shaped. Replace the flat side of the knob onto the flat side of the stem.

Sealed burner assemblies

Turn all controls **OFF** before removing the burner parts.

The burner grates, burner caps and burner ring sub-assemblies can be lifted off, making them easy to clean.

CAUTION: DO NOT OPERATE THE BURNER WITHOUT ALL BURNER PARTS IN PLACE.

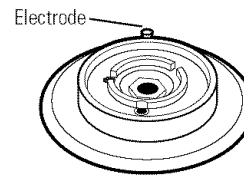

The electrode of the spark igniter is behind each burner. **When one burner is turned to “ON” to light, all the burners spark.** Do not

attempt to disassemble or clean around any burner while another burner is on. An electric shock may result, which could cause you to knock over hot cookware.

Burner sub-assemblies

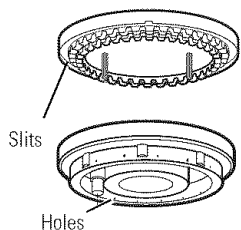

Use a sewing needle, twist-tie and/or toothbrush to unclog the small holes and slits in the burner heads and burner rings.

NOTE: Before removing the burner parts, remember their size and location. Replace them in the same location after cleaning for proper burner operation.

For proper ignition, make sure the small holes in the burner rings are kept open. A sewing needle or wire twist-tie works well to unclog them.

The slits in the burner heads of your cooktop must be kept clean at all times for an even, unhampered flame.

You should clean the surface burners routinely, especially after bad spills, which could clog these openings.

To remove burned-on food, soak the burner heads and rings in a solution of mild liquid detergent and hot water for 20–30 minutes. For more stubborn stains, use a toothbrush.

Clean the burner bases in place on the cooktop.

To remove the burner parts:

1. Lift off the burner cap and burner head.
2. Remove the burner ring locking nut using a 1 $\frac{1}{16}$ " socket wrench, crescent wrench or channel-lock pliers.
3. Lift off the burner ring. **Do not remove the burner bases.**

Before putting the burner parts back, shake out excess water and then dry them thoroughly by setting them in a warm oven for 30 minutes.

Replace the burner parts. Make sure that the rings, heads and caps are replaced in the correct location. There are four medium sets and one large set of rings, heads and caps.

To replace the burner parts:

Make sure all parts are for the correct burner, are in the correct location and are firmly seated.

1. Align the locator pin on the burner ring into the labeled hole in the burner base. Seat in place and push toward the electrode to set gap properly.
2. Replace the burner ring locking nut and hand-tighten. Using the wrench or pliers, turn the nut 1/4 turn to secure it in place.
3. Align the two locator pins in the burner head into the holes in the burner ring. Seat in place. **NOTE:** Make sure the burner head pins completely engage in the burner ring holes and that burner head is level.

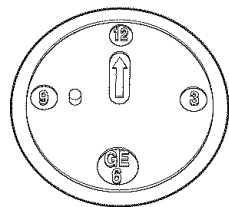

To aid reassembly, each brass Burner Head is marked with a clock face. Replace the Burner Head with the arrow pointing to the rear of the cooktop (12 o'clock position).

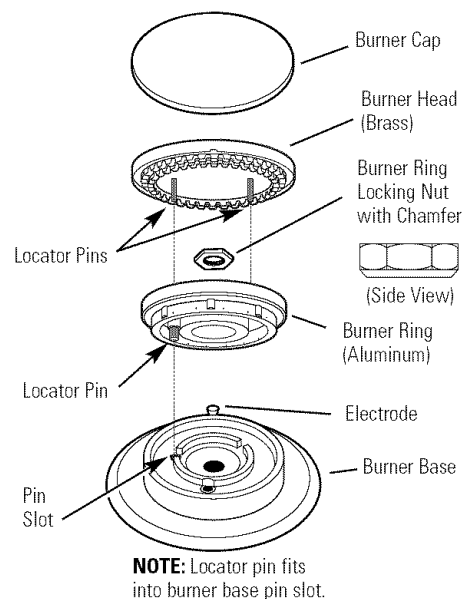
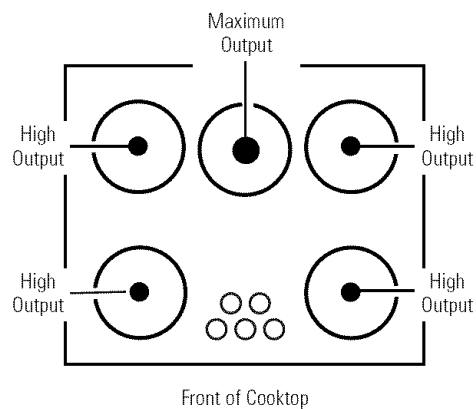

Maximum Output Center Burner

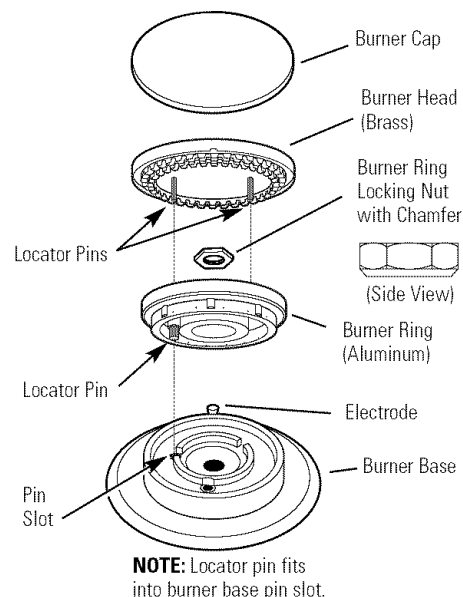

High Output Burners

Burner caps

Do not use a steel wool pad; it will scratch the surface.

Lift off when cool. Wash burner caps in hot, soapy water and rinse with clean water. You may scour with a plastic scouring pad to remove burned-on food particles.

Dry them in a warm oven or with a cloth—don't reassemble them wet. Replace the burner caps.

Make sure that caps are replaced on the correct size burner. There are four medium sets and one large set of rings, heads and caps.

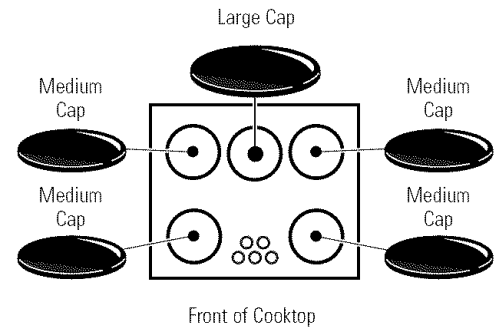

Burner grates

Cast-iron burner grates should be washed regularly and especially after spillovers.

Wash them in hot, soapy water and rinse with clean water. Dry the grates with a cloth—don't put them back on the cooktop wet. When replacing the grates, be sure they're positioned securely over the burners.

To get rid of burned-on food, place the grates in a covered container or plastic bag. Add 1/4 cup ammonia and let them soak for 30 minutes. Wash, rinse well and dry.

The grates may also be cleaned in a dishwasher.

Although they are durable, the grates will gradually lose their shine, regardless of the best care you can give them. This is due to their continual exposure to high temperatures.

Do not operate a burner for an extended period of time without cookware on the grate. The finish on the grate may chip without cookware to absorb the heat.

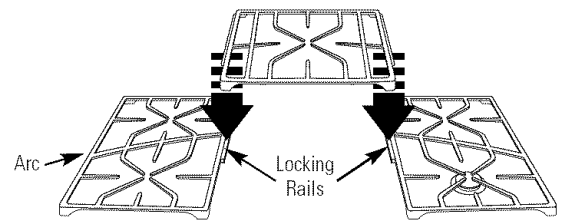

After cleaning, replace the two side grates with their locking rails toward the center. Replace the center grate so that a continuous "arc" is formed with the center ribs of all three grates. Make sure the rails on the center grate are locked over the rails on the side grates and that all grates are stable and level.

Rubber Grate Feet

For stability, your cooktop has two rubber feet on each leg of the burner grates. If any of these rubber feet should become damaged or lost, replace it with one of the extra rubber feet supplied with your cooktop.

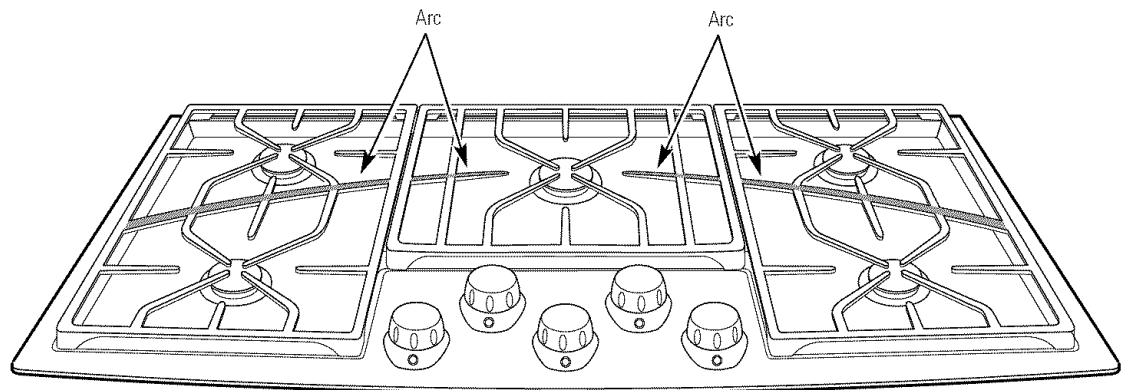

Before You Call For Service

Gas Cooktop

*Questions?
Before you
call for
service...*

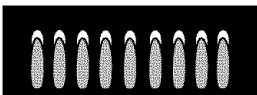
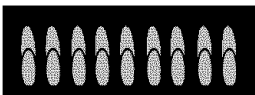
PROBLEM	POSSIBLE CAUSE
<p>BURNERS DO NOT LIGHT OR SPARK RANDOMLY</p>	<ul style="list-style-type: none"> • Make sure electrical plug is plugged into a live power outlet. • Gas not turned on. • Burner parts not replaced correctly. • Holes in the simmer rings or slits in the burner rings may be clogged. • Clogged orifice or wet due to spillage or burners not dry after cleaning. • Rubber discs below knobs are not pushed down through the bezel to the valve.
<p>BURNERS HAVE YELLOW OR YELLOW-TIPPED FLAMES</p>	<ul style="list-style-type: none"> • Burner parts not replaced correctly. <div style="display: flex; justify-content: space-around; align-items: flex-start;"> <div style="text-align: center;">  <p>A. Yellow flames: <i>Call for service.</i></p> </div> <div style="text-align: center;">  <p>B. Yellow tips on outer cones: <i>Normal for LP gas.</i></p> </div> <div style="text-align: center;">  <p>C. Soft blue flames: <i>Normal for natural gas.</i></p> </div> </div> <ul style="list-style-type: none"> • If burner flames look like (A), call for service. Normal burner flames should look like (B) or (C), depending on the type of gas.
<p>BURNER FLAMES VERY LARGE OR YELLOW</p>	<ul style="list-style-type: none"> • If cooktop is connected to LP gas, contact the person who installed your cooktop or made the conversion.
<p>BURNER CONTROL KNOB WILL NOT TURN</p>	<ul style="list-style-type: none"> • When the knob is at the OFF position, it must be pushed in before it can be turned, and it can only be turned in a counterclockwise direction. Similarly, when the knob is in the LOW or HIGH positions, it must also be pushed in to change flame settings.

With the purchase of your new Monogram appliance, receive the assurance that if you ever need information or assistance from GE, we'll be there. All you have to do is call—toll-free!

GE Answer Center®

800.626.2000

Whatever your question about any Monogram major appliance, GE Answer Center® information service is available to help. Your call—and your question—will be answered promptly and courteously. And you can call any time. GE Answer Center® service is open 24 hours a day, 7 days a week.

OR

Visit our Website at: ge.com

In-Home Repair Service

800.444.1845

A GE consumer service professional will provide expert repair service, scheduled at a time that's convenient for you. Many GE Consumer Service company-operated locations offer you service today or tomorrow, or at your convenience (7:00 a.m. to 7:00 p.m. weekdays, 9:00 a.m. to 2:00 p.m. Saturdays). Our factory-trained technicians know your appliance inside and out—so most repairs can be handled in just one visit.

For Customers With Special Needs...

800.626.2000

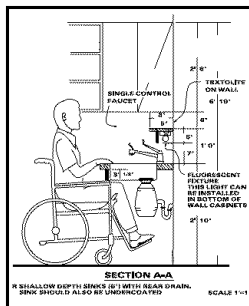

GE offers, free of charge, a brochure to assist in planning a barrier-free kitchen for persons with limited mobility.

Consumers with impaired hearing or speech who have access to a TDD or a conventional teletypewriter may call 800.TDD.GEAC (800.833.4322) to request information or service.

Service Contracts

800.626.2224

You can have the secure feeling that GE Consumer Service will still be there after your warranty expires. Purchase a GE contract while your warranty is still in effect and you'll receive a substantial discount. With a multiple-year contract, you're assured of future service at today's prices.

Parts and Accessories

800.626.2002

Individuals qualified to service their own appliances can have parts or accessories sent directly to their home. The GE parts system provides access to over 47,000 parts...and all GE Genuine Renewal Parts are fully warranted. VISA, MasterCard and Discover cards are accepted.

User maintenance instructions contained in this manual cover procedures intended to be performed by any user. Other servicing generally should be referred to qualified service personnel. Caution must be exercised, since improper servicing may cause unsafe operation.

YOUR MONOGRAM COOKTOP WARRANTY

Staple sales slip or cancelled check here. Proof of original purchase date is needed to obtain service under warranty.

WHAT IS COVERED

LIMITED ONE-YEAR WARRANTY

For one year from date of original purchase, we will provide, free of charge, parts and service labor in your home to repair or replace **any part of the cooktop** that fails because of a manufacturing defect.

.....

This warranty is extended to the original purchaser and any succeeding owner for products purchased for ordinary home use in the 48 mainland states, Hawaii and Washington, D.C. If the product is located in an area where service by a GE Authorized Servicer is not available, you may be responsible for a trip charge or you may be required to bring the product to an Authorized GE Service Location for service. In Alaska the warranty is the same except that it is LIMITED because you must pay to ship the product to the service shop or for the service technician's travel costs to your home.

All warranty service will be provided by our Factory Service Centers or by our authorized Customer Care® servicers during normal working hours.

Should your appliance need service, during warranty period or beyond, call 800.444.1845. Please have your serial number and model number available when calling for service.

WHAT IS NOT COVERED

- | | |
|--|--|
| <ul style="list-style-type: none"> • Service trips to your home to teach you how to use the product. • Replacement of house fuses or resetting of circuit breakers. • Damage to the product caused by accident, fire, floods or acts of God. • Failure of the product if it is used for other than its intended purpose or used commercially. • Improper installation, delivery or maintenance. | <p>If you have an installation problem, contact your dealer or installer. You are responsible for providing adequate electrical, gas, exhausting and other connecting facilities as described in the Installation Instructions provided with the product.</p> <ul style="list-style-type: none"> • Incidental or consequential damage caused by possible defects with this appliance. • Damage caused after delivery. • Product not accessible to provide required service. |
|--|--|

EXCLUSION OF IMPLIED WARRANTIES—Your sole and exclusive remedy is product repair as provided in this Limited Warranty. Any implied warranties, including the implied warranties of merchantability or fitness for a particular purpose, are limited to one year or the shortest period allowed by law.

Some states do not allow the exclusion or limitation of incidental or consequential damages, so the above limitation or exclusion may not apply to you. This warranty gives you specific legal rights, and you may also have other rights which vary from state to state.

To know what your legal rights are in your state, consult your local or state consumer affairs office or your state's Attorney General.

Warrantor: General Electric Company, Louisville, KY 40225

GE Service Protection Plus™

GE, a name recognized worldwide for quality and dependability, offers you Service Protection Plus™—comprehensive protection on all your appliances—**No Matter What Brand!**

Benefits Include:

- Backed by GE
- All brands covered
- Unlimited service calls
- All parts and labor costs included
- No out-of-pocket expenses
- No hidden deductibles
- One 800 number to call

***We'll Cover Any Appliance.
Anywhere. Anytime.****

You will be completely satisfied with our service protection or you may request your money back on the remaining value of your contract. No questions asked. It's that simple.

Protect your refrigerator, dishwasher, washer and dryer, range, TV, VCR and much more—**any brand!** Plus there's no extra charge for emergency service and low monthly financing is available. Even icemaker coverage and food spoilage protection is offered. You can rest easy, knowing that all your valuable household products are protected against expensive repairs.

Place your confidence in GE and call us in the U.S. toll-free at **800.626.2224** for more information.

*All brands covered, up to 20 years old, in the continental U.S.



Please place in envelope and mail to:

General Electric Company
Warranty Registration Department
P.O. Box 32150
Louisville, KY 40232-2150

Consumer Product Ownership Registration

Dear Customer:

Thank you for purchasing our product and thank you for placing your confidence in us.

We are proud to have you as a customer!

Follow these three steps to protect your new appliance investment:

1

Complete and mail your Consumer Product Ownership Registration today. Have the peace of mind of knowing we can contact you in the unlikely event of a safety modification.

2

After mailing the registration below, store this document in a safe place. It contains information you will need should you require service. Our service number is 800 GE CARES (800.432.2737).

3

Read your Owner's Manual carefully. It will help you operate your new appliance properly.

Model Number

Serial Number

Important: If you did not get a registration card with your product, detach and return the form below to ensure that your product is registered, or register online at ge.com.

 Cut here

Consumer Product Ownership Registration



Model Number

Serial Number

Mr. Ms. Mrs. Miss

First Name

Last Name

Street Address

Apt. #

E-mail Address*

City

State

Zip Code

Date Placed In Use
Month

Day

Year

Phone Number



GE Consumer & Industrial Appliances
General Electric Company
Louisville, KY 40225
ge.com

* Please provide your e-mail address to receive, via e-mail, discounts, special offers and other important communications from GE Appliances (GEA).

Check here if you do not want to receive communications from GEA's carefully selected partners.

FAILURE TO COMPLETE AND RETURN THIS CARD DOES NOT DIMINISH YOUR WARRANTY RIGHTS.

For more information about GEA's privacy and data usage policy, go to ge.com and click on "Privacy Policy" or call 800.626.2224

164D4290P369

49-80378

11167 B

12-05 JR

Printed in the United States