



# Zoneline<sup>®</sup> Air Conditioners

*Safety Instructions* .....2

*Operating Instructions*

Air Direction .....4  
Auxiliary Controls .....5-9  
Controls .....3  
Vent Control .....4

*Care and Cleaning*

Air Filters .....11  
Base Pan .....10  
Outdoor Coils .....10  
Room Cabinet and Case .....10

*Installation Instructions*

Electrical Supply .....14-16  
Installing the Zoneline ....17, 18  
Optional Drain Kit .....19  
Preparation .....12  
Replacing an Existing Unit? ...13

*Troubleshooting Tips* .....20

Normal Operating Sounds ....21

*Consumer Support*

Consumer Support ...Back Cover  
Product Registration .....25, 26  
Warranty .....27

**Owner's Manual and  
Installation Instructions**

*Heat/Cool Model 2500  
Heat Pump Model 3500*

**Write the model and serial  
numbers here:**

**Model #** \_\_\_\_\_

**Serial #** \_\_\_\_\_

Find these numbers on a label  
behind the room cabinet on the  
base pan.



## **IMPORTANT SAFETY INFORMATION. READ ALL INSTRUCTIONS BEFORE USING.**

### **⚠ WARNING!**

*For your safety, the information in this manual must be followed to minimize the risk of fire or explosion, electric shock, or to prevent property damage, personal injury, or loss of life.*



### **SAFETY PRECAUTIONS**

- This Zoneline must be properly installed in accordance with the Installation Instructions before it is used. See the Installation Instructions in the back of this manual.
- Immediately repair or replace all electric service cords that have become frayed or otherwise damaged.
- Unplug or disconnect the Zoneline at the fuse box or circuit breaker before making any repairs.

**NOTE:** We strongly recommend that any servicing be performed by a qualified individual.

#### ***Replacing an existing unit?***

For details, see the Installation Instructions in this manual.



**READ AND FOLLOW THIS SAFETY INFORMATION CAREFULLY.**

**SAVE THESE INSTRUCTIONS**

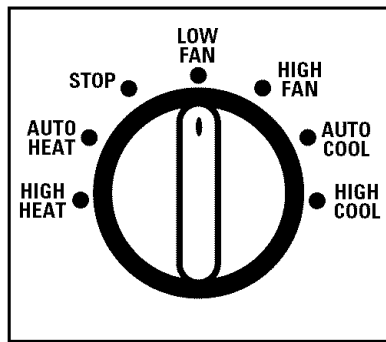

**MODE CONTROL**

1

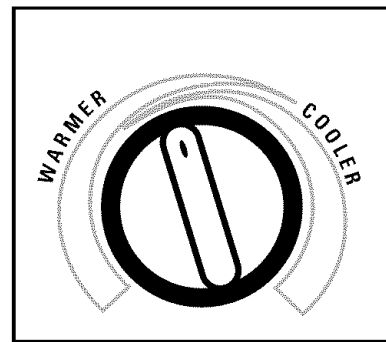

**TEMP CONTROL**

2



## Controls

**1 Mode Control**  
**HIGH COOL** and **AUTO COOL** provide cooling with different fan speeds.

**HIGH HEAT** and **AUTO HEAT** provide heating with different fan speeds.

**LOW FAN** or **HIGH FAN** provides air circulation and filtering without cooling or heating.

**NOTE:** If you move the switch from a cool or heat setting to **STOP** or to a fan setting, the unit has an automatic 3-minute delay before allowing the compressor to restart in the cool or heat mode.

**2 Temp Control**  
The temp control is used to maintain the room temperature. The compressor will cycle on and off to keep the room at the same comfort level. When you turn the knob to **COOLER** (blue) the indoor air will become cooler. Turn the knob to **WARMER** (red) and the indoor air will become warmer.

### **3500 Series only**

When the outdoor temperature is lower than 25°F, heat is provided by the electric heater in the air conditioner instead of by the heat pump.

### **About Your Heat Pump (3500 Series only)**

Heat pumps can save money by removing heat from the outside air—even when the outside temperature is below freezing—and releasing that heat indoors.

To get the best performance from your heat pump, don't change the room thermostat very often. Raising the heat setting 2–3 degrees will cause the Zoneline to use its electric heating elements in order to reach the new temperature setting quickly.

There is a three minute minimum compressor run time at any setting to prevent short cycling.

The indoor fan motor starts before the compressor and stops after the compressor cycles off.

The electric heating elements use much more electricity than heat pumps and cost more to operate.

## Other features your Zoneline may have.

### Ventilation Control

The ventilation control lever is located at the upper left side of the Zoneline unit, behind the room cabinet.

**NOTE:** The vent door shipping hardware must be removed before using the vent control lever. See the Installation Instructions in this manual.

When set at **CLOSE**, only the air inside the room is circulated and filtered.

When set at **OPEN**, some outdoor air will be drawn into the room. This will reduce the heating or cooling efficiency.

**Energy Tip:** Keep the vent control at **CLOSE**. The room air will be filtered and circulated.

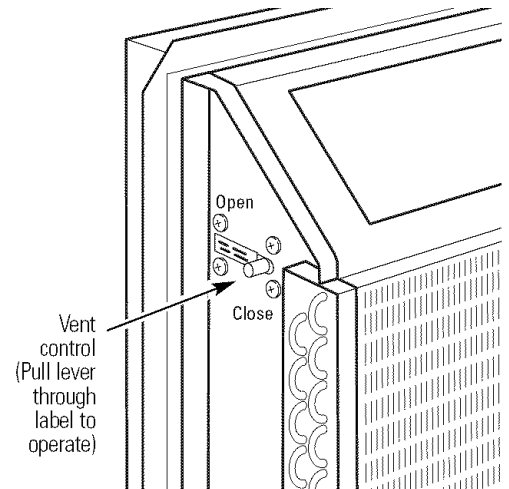

### To Remove the Room Cabinet

Additional controls are located behind the room cabinet.

**To remove:** Pull out at the bottom to release it from the tabs (1). Then lift up (2).

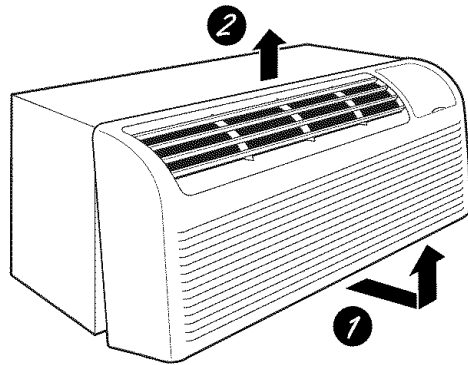

**To replace:** Place the tabs over the top rail (1). Push inward at the bottom until it snaps into place (2).

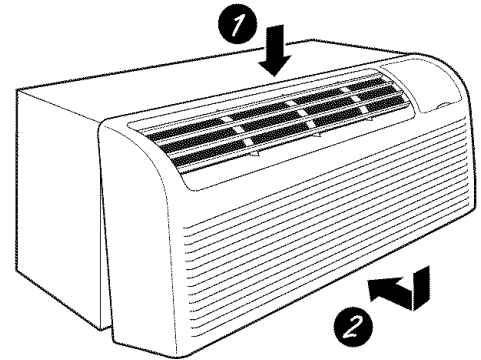

### Air Direction

To adjust the air direction, remove the room cabinet. Remove the 7 louver screws that hold the louver insert in place. Flip the louver insert 180°, replace the screws and the room cabinet.

Remove the room cabinet and flip the louver insert to change the air direction.

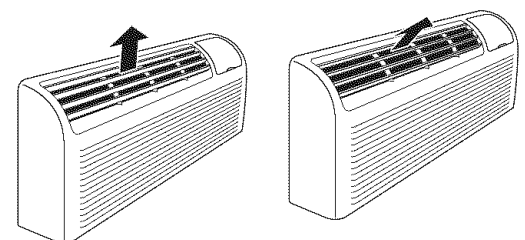
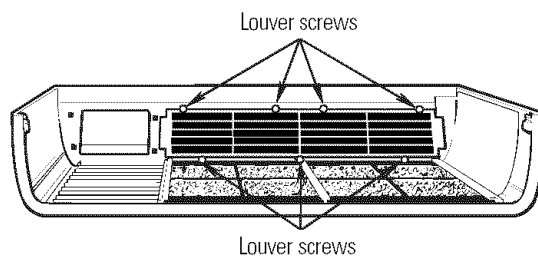

## Auxiliary Controls – Dip Switches

The auxiliary dip switch controls are located behind the room cabinet, through an opening in the control panel.

Remove the room cabinet. See the *To Remove the Room Cabinet* section.

The factory settings will be in the **DOWN** position.

The owner is responsible for checking switches and ensuring they are in the desired position.

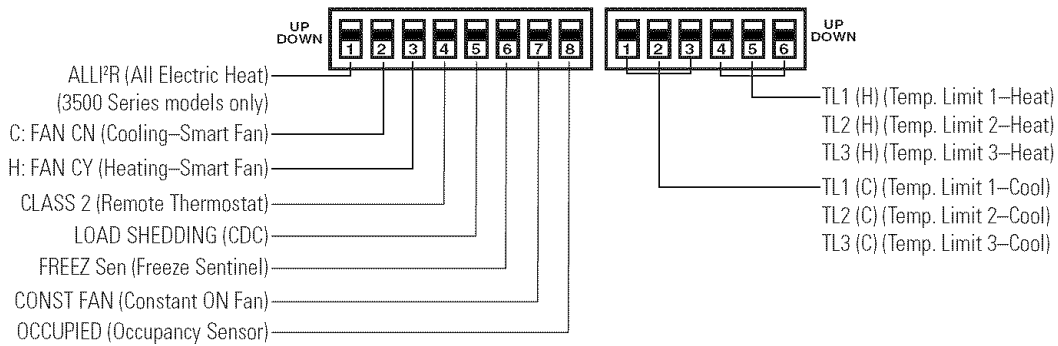
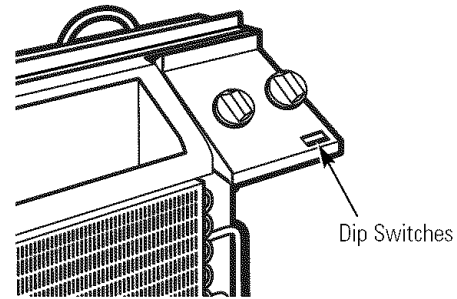

### All Electric Heat

This electric heat option functions only on the 3500 Series models. When this switch is enabled (**UP**), heat pump operation is locked out, causing the unit to provide only electric resistance heat.

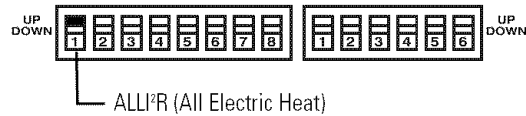

### Cooling–Smart Fan

When this switch is enabled (**UP**), it allows the indoor fan to cycle on/off with the compressor. When this switch is disabled (**DOWN**), it allows the indoor fan to run continuously.

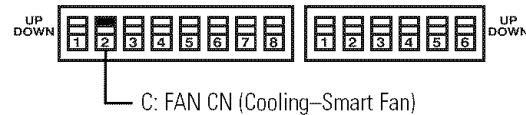

### Heating–Smart Fan

When this switch is enabled (**UP**), it allows the indoor fan to run continuously. When this switch is disabled (**DOWN**), it allows the indoor fan to cycle on/off with the heat pump or heater operation.



## Auxiliary controls on your Zoneline.

### Remote Thermostat—Class 2

When this switch is enabled (**UP**), it allows the unit to operate off of a Class 2 Remote Control Wall Thermostat. The unit controls are disabled.

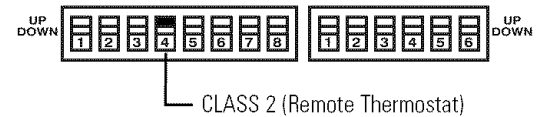

### Load Shedding (CDC)

This feature is active only if the unit is in CDC mode. When this switch is enabled (**UP**), the indoor fan can be turned ON or OFF with the unit controls.

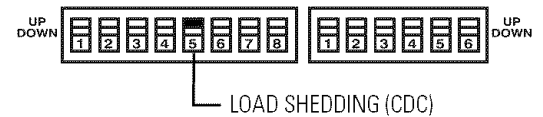

### Freeze Sentinel

When this switch is enabled (**UP**), it turns OFF the freeze sentinel protection feature. With the switch disabled (**DOWN**), the freeze sentinel is activated which automatically provides heat without user interface. This helps to prevent plumbing damage by turning the heater and indoor fan ON at 41° F and OFF at 46° F.

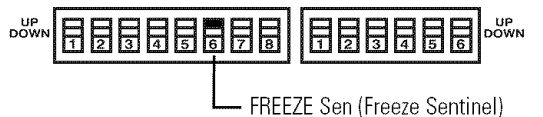

### Constant ON Fan

When this switch is enabled (**UP**), it allows the indoor fan to run continuously, at high speed, even if the unit is in the STOP position.

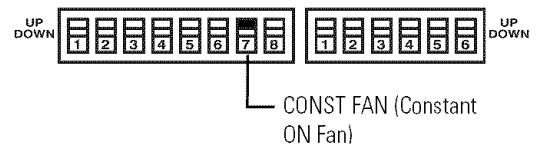

### Occupancy Sensor

When this switch is enabled (**UP**), it allows the unit to utilize an infrared motion sensor and a door switch for occupancy detection. This feature allows an energy management system to be installed and operated in conjunction with the unit.

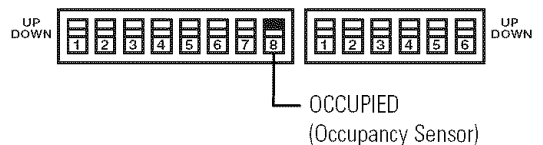

### Temperature Limiting

Temperature limiting can reduce energy costs by limiting the lowest temperature that can be set for cooling and the highest temperature that can be set for heating. Temperature limiting is controlled by the second six auxiliary switches.

The first three switches are used to select the cooling limits and the remaining three switches are used to control the heating limits. This feature is not available with the Remote Thermostat—Class 2.

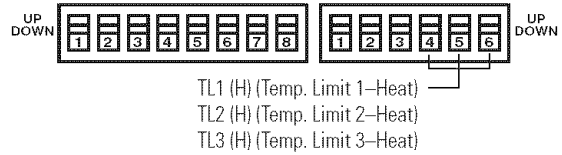
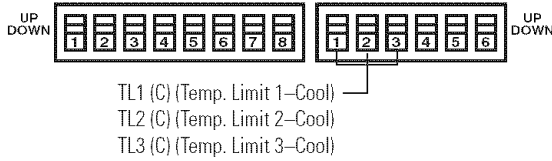

Temperature limiting during COOL mode (all temperatures shown in °F)			
UP	DOWN	Minimum	Maximum
NONE	1, 2, 3	60°	85°
1	2, 3	64°	85°
1, 2	3	66°	85°
2	1, 3	68°	85°
2,3	1	70°	85°
1, 2, 3	NONE	72°	85°
1, 3	2	74°	85°
3	1, 2	76°	85°

Temperature limiting during HEAT mode (all temperatures shown in °F)			
UP	DOWN	Minimum	Maximum
NONE	4, 5, 6	60°	85°
4	5, 6	60°	80°
4, 5	6	60°	78°
5	4, 6	60°	76°
5,6	4	60°	74°
4, 5, 6	NONE	60°	72°
4, 6	5	60°	70°
6	4, 5	60°	65°

# Auxiliary controls on your Zoneline.

## Auxiliary Controls—Terminal Connections

The auxiliary controls are located behind the room cabinet beneath the control panel.

- 1 Remove the room cabinet. See the *To Remove the Room Cabinet* section.
- 2 Remove the screw from the control panel corner.
- 3 Remove the control panel and knobs by grasping the control panel on both sides and pulling forward. The knobs will pull off with the control panel.
- 4 After all desired settings have been made, replace the control panel, knobs and room cabinet by reversing steps 1–3. **NOTE:** The knob stem is **D** shaped. Install the flat of the shaft to the flat of the knob.

The owner is responsible for making all connections and setting the appropriate dip switches.

Insert the building hook-up wires into the bottom of the terminal and tighten screw securely to make the desired connections.

### CAUTION:

Improper wiring may damage the Zoneline electronics. No common busing is permitted. Damage or erratic operation may result. A separate wire pair must be run from each separate controlling switch to each individual Zoneline.

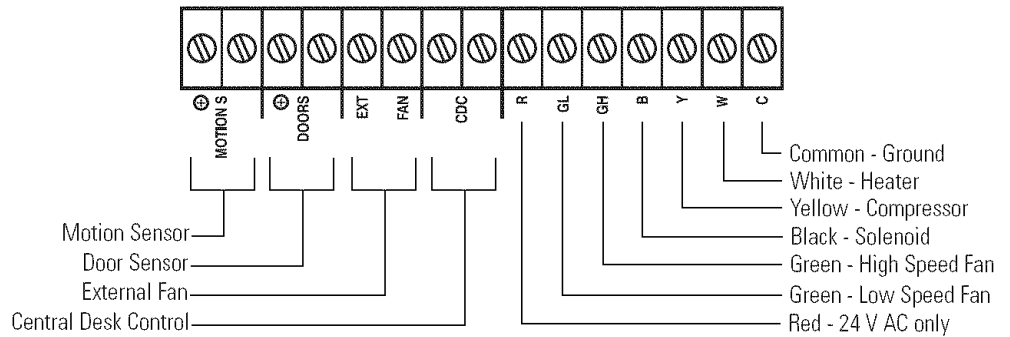

## Motion Sensor (Obtained locally)

When connected, the wall mounted motion sensor will detect motion in the room and automatically turn the unit ON or OFF.

The door and motion sensors work together to automatically turn the unit ON or OFF.

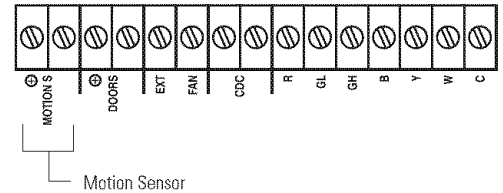



### Door Sensor (Obtained locally)

When connected, the door sensor will detect when the door in the room was opened or closed. This feature must be used in conjunction with the motion sensor.

The door and motion sensors work together to automatically turn the unit ON or OFF.

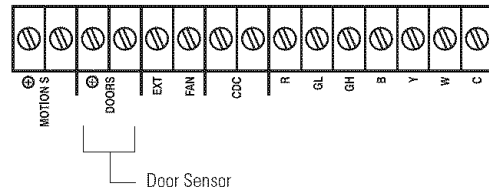

### External Fan (Obtained locally)

When connected, an auxiliary or external fan can be controlled with the indoor fan motor on the Zoneline. Connections provide 24 V AC to energize a remote relay, turning on the external fan.

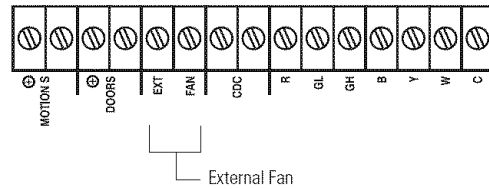

### Central Desk Control

When connected, the unit can be turned ON or OFF with a switch located at the Central Control Panel. A separate wire pair must be run from each separate controlling switch to each individual Zoneline.

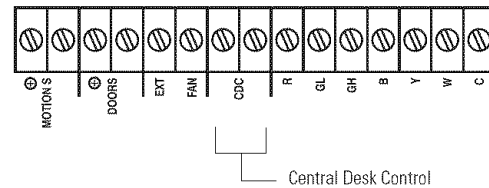

### Remote Thermostat

When connected, the unit will be controlled by a remote thermostat.

**NOTE:** The number 4 dip switch must be in the enabled (**UP**) position to activate the remote thermostat. (See the installation instructions supplied with the remote thermostat).

### IMPORTANT:

The Zoneline thermostat connections provide 24 V AC only.

If using a digital/electronic wall thermostat, you must set it to the 24 V AC setting. See the Installation Instructions for the wall thermostat.

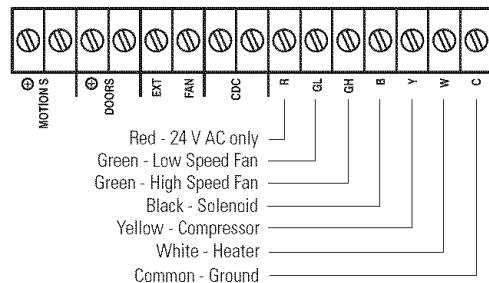

### CAUTION:

Damage to a wall thermostat or to the Zoneline electronics can result from improper connections. Special care must be used in connecting blue and black wires. No line voltage connections should be made to any circuit. Isolate all wires in building from line voltage.

## Care and cleaning.

### Room Cabinet and Case

Turn the Zoneline off and disconnect the power supply.

To clean, use water and a mild detergent. Do not use bleach or abrasives. Some commercial cleaners may damage the plastic parts.

### Outdoor Coils

The coils on the outdoor side of the Zoneline should be checked regularly. If they are clogged with dirt or soot, they may be professionally steam cleaned, a service available through your GE service outlet. You will need to remove the unit to inspect the coils because the dirt build-up occurs on the inside.

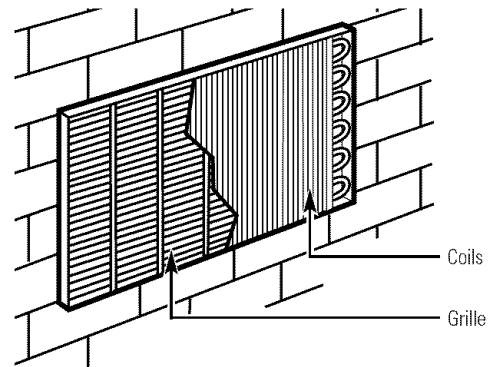

*Clean the outside coils regularly.*

### Base Pan

In some installations, dirt or other debris may be blown into the unit from the outside and settle in the base pan (the bottom of the unit).

In some areas of the United States a “jell-like” substance may be seen in the base pan.

Check it periodically and clean, if necessary.

To maintain optimum performance, clean the filters at least every 30 days.

## Air Filters

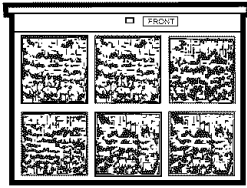

Dirty filter—Needs cleaning

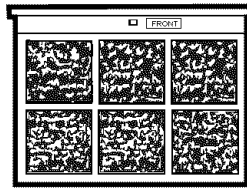

Clogged filter—Greatly reduces cooling, heating and airflow.

### Turn the Zoneline off before cleaning.

The most important thing you can do to maintain the Zoneline is to clean the filter at least every 30 days. Clogged filters reduce cooling, heating and air flow.

### Keeping these filters clean will:

- Decrease cost of operation.
- Save energy.
- Prevent clogged heat exchanger coils.
- Reduce the risk of premature component failure.

### To clean the air filters:

- Vacuum off the heavy soil.
- Run water through the filters.
- Dry thoroughly before replacing.

### To remove the air filters:

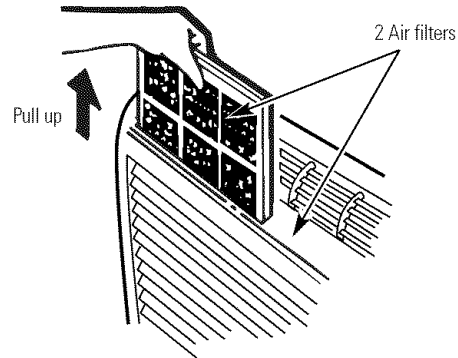

### To replace the air filters:

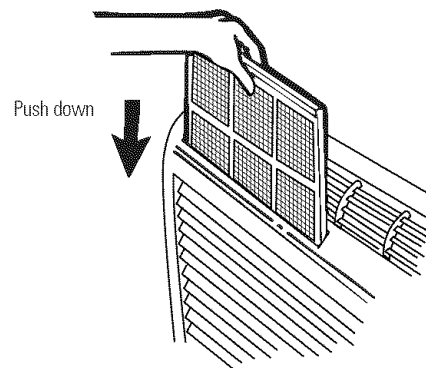

**⚠ CAUTION:** Do not operate the Zoneline without the filters in place. If a filter becomes torn or damaged it should be replaced immediately.

Operating without the filters in place or with damaged filters will allow dirt and dust to reach the in-door coil and reduce the cooling, heating, airflow and efficiency of the unit.

Replacement filters are available from your salesperson, GE dealer, GE Service and Parts Center or authorized Customer Care® servicers.

# Installation Instructions

# Zoneline Air Conditioners

Questions? Call 800.GE.CARES (800.432.2737) or Visit our Website at: [www.GEAppliances.com](http://www.GEAppliances.com)

## BEFORE YOU BEGIN

Read these instructions completely and carefully.

- **IMPORTANT** — Save these instructions for local inspector's use.
- **IMPORTANT** — Observe all governing codes and ordinances.
- **Note to Installer** — Be sure to leave these instructions with the owner.
- **Note to Owner** — Keep these instructions for future reference.
- Proper installation is the responsibility of the installer.
- Product failure due to improper installation is not covered under the Warranty.

## TOOLS YOU WILL NEED



Phillips screwdriver

## IMPORTANT ELECTRICAL SAFETY—READ CAREFULLY

### ⚠ CAUTION:

- Follow the National Electrical Code (NEC) or local codes and ordinances.
- For personal safety, this Zoneline must be properly grounded.
- Protective devices (fuses or circuit breakers) acceptable for Zoneline installations are specified on the nameplate of each unit.
- Do not use an extension cord with this unit.
- Aluminum building wiring may present special problems—consult a qualified electrician.
- When the unit is in the STOP position there is still voltage to the electrical controls.
- Disconnect the power to the unit before servicing by:
  - 1 Removing the power cord (if it has one) from the wall receptacle.OR
  - 2 Removing the branch circuit fuses or turning the circuit breakers off at the panel.

## ZONELINE COMPONENTS

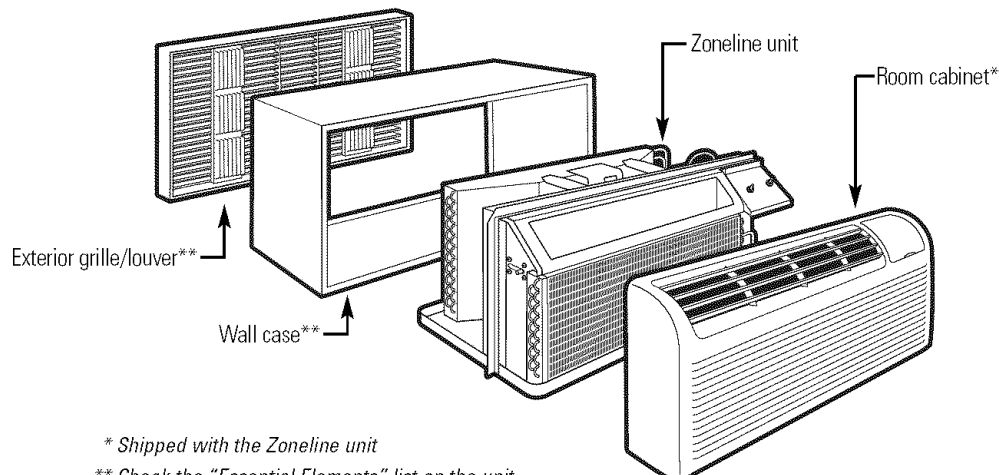

\* Shipped with the Zoneline unit

\*\* Check the "Essential Elements" list on the unit

# Installation Instructions

## REPLACING AN EXISTING UNIT?

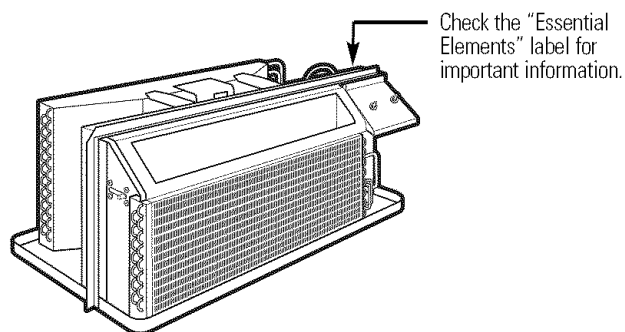

### Use the correct wall case

This unit is designed to be installed in a GE plastic or insulated metal wall case. This minimizes condensation from forming on the room side of the case.

If the current wall case is not insulated, you can reduce the possibility of condensation forming by installing insulation kit RAK901L, available where you purchased the unit.

### Use the correct outdoor grille

You should use the outdoor grilles shown on the "Essential Elements" label on the top of the unit.

- If an existing grille is not replaced, capacity and efficiency will be reduced and the unit may fail to operate properly or fail prematurely. A deflector kit, RAK40, may be used with grilles that were not designed for your new GE Zonelines. The RAK40 contains air deflectors and gaskets that mount to the unit to direct the hot exhaust air away from the air intake to allow the unit to function properly. The grille must have a 65% minimum free area.
- Any vertical deflectors in the existing rear grille should be removed to decrease condenser air recirculation which can cause the unit to "short-cycle" and lead to premature component failure.

### Replacing a ducted unit

#### New ducted installation:

If this unit is to be installed in a new ducted application using a duct adapter kit, the kit must be installed before the unit is placed in the wall case. The installation instructions are packed with the kit.

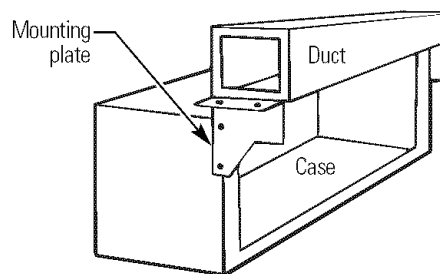

#### Existing ducted installation:

Replacement of an existing ducted unit may require different components. Request this information from your sales representative.

- **Replacing 230/208 volt units:**  
See page 14.
- **Replacing 265 volt units:**  
See pages 15 and 16.

# Installation Instructions

## HOW TO CONNECT

- 1 Remove the room cabinet.
- 2 Connect to electrical power.
- 3 See the special instructions below for applicable supply voltages.
- 4 Reinstall the room cabinet.

## 230/208 VOLT ELECTRICAL SUPPLY

All wiring, including installation of the receptacle, must be in accordance with the NEC and local codes, ordinances and regulations.

This unit is equipped with a line cord for appropriate amperage wall receptacle. See below.



**Tandem**  
15 Amp.



**Perpendicular**  
20 Amp.



**Large Tandem**  
30 Amp.

*230/208 volt receptacle configuration.*

Order Kit RAK4002A for 230/208 volt direct connection.

230/208 volt models may be installed using one of the following electrical subbases:

<b>Branch Circuit and Unit Amperage Rating</b>	<b>Proper GE Subbase Kit</b>
15/20	RAK204D20
30	RAK204D30

Electrical subbases provide a flexible enclosure for direct connection or enclosed receptacles.

The instructions provided with the selected subbase kit must be carefully followed. It is the responsibility of the installer to ensure the connection of components is done in accordance with these instructions and all electrical codes.

# Installation Instructions

## 265 VOLT ELECTRICAL SUPPLY

### **⚠ WARNING:**

Connection of this 265 V AC product to a branch circuit **MUST** be done by direct connection in accordance with the National Electric Code. Plugging this unit into a building mounted exposed receptacle is not permitted by code.

These models must be installed using one of the following methods:

**A** Electrical subbase kits are available to provide a flexible enclosure for direct connection.

<b>Branch Circuit and Unit Amperage Rating</b>	<b>Proper GE Subbase Kit</b>
15	RAK204E15
20	RAK204E20
30	RAK204E30

The instructions provided with the selected subbase kit must be carefully followed. It is the responsibility of the installer to ensure the connection of components is done in accordance with these instructions and all electrical codes.

**B** For direct connection to branch circuit wiring inside the provided junction box without using a subbase kit, cut the cord, strip the wire ends and connect as follows.

### **1 REMOVE JUNCTION BOX**

- 1 Remove the junction box cover by taking out the front two screws.
- 2 Remove the junction box by taking out the top and bottom rear screws. Note how the tabs on the lower left side of the junction box serve to hold the side in place. This will help when the box is being reinstalled. The cord will be coiled up inside the junction box.

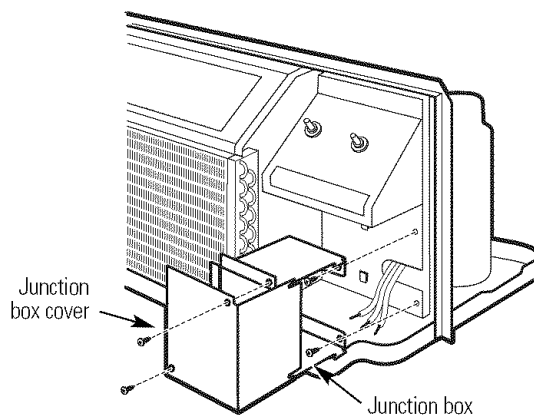

### **2 CUT AND STRIP THE CORDSET**

- 1 Measure 6" down the cord from the strain relief securing the cord to the unit and cut the cord through at this point.
- 2 Carefully split the cord insulation at the center for 2" so as to separate into three insulated wires. Be careful not to cut through the center green ground wire insulation.
- 3 Strip 3/4" of the insulation away at the end of each of the three wires (L1, Neutral and Ground). The Neutral wire is identified by molded rib along its entire length. The L1 (Hot) wire insulation is smooth.

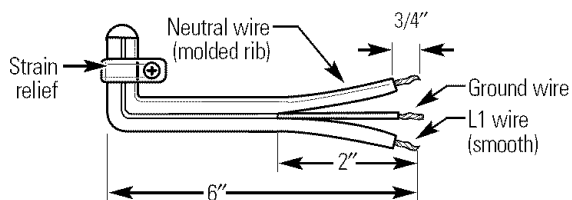

# Installation Instructions

## 265 VOLT ELECTRICAL SUPPLY

**NOTE:** Order Kit RAK4002CW to enable a quick disconnect inside the junction box.

### 3 ATTACH CONDUIT

- 1 Use the round knockout at the bottom of the junction box to attach conduit coming from the branch circuit. Remove the knockout, attach the conduit and bring wires into the junction box. Leave 6" of wire free at the end of the conduit to allow connections to be made.

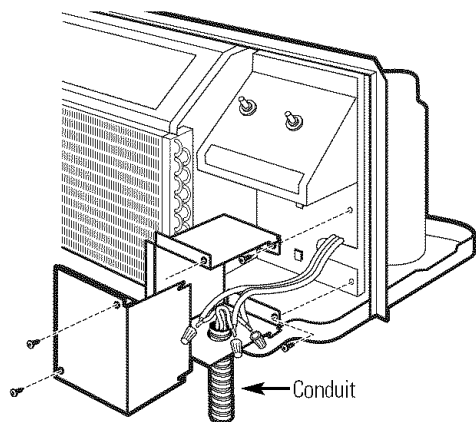

- 2 If a fuse and fuseholder are to be used, the knockout at the top of the box is for mounting a Buss Fuseholder. Be sure the fuse and fuseholder are of the same rating as the branch circuit. Leadwires at the fuse can be either soldered in place or attached using UL-listed 1/4" female (receptacle) crimp connectors.

### 4 REINSTALL JUNCTION BOX

- Reinstall the junction box by engaging the left tabs on the lower right face of the unit, aligning the screw holes at the top and bottom and driving the two screws until secure. Be sure that all wire leads are inside the box and not pinched between the box and the unit.

The identified (ribbed) Neutral wire of the cordset **MUST** be connected to the white Neutral wire of the branch circuit. The green insulated ground wire from the unit **MUST** be connected to the branch circuit ground wire.

### 5 MAKE WIRING CONNECTIONS

- 1 Make all wire connections by using appropriate UL-listed electrical connectors and techniques (black to black, white to white and green to green).
- 2 Carefully tuck all wires and connections back inside the junction box. Be sure there are no loose connections or stray uninsulated wires exposed.
- 3 Place the junction box cover in place. Replace the two screws removed earlier and tighten securely.
- 4 Discard the unused portion of the plug and the cordset.



# Installation Instructions

## INSTALLING THE ZONELINE

### 1 INSTALL THE WALL CASE AND EXTERIOR GRILLE

The RAB71 series or RAB77 wall case must be properly installed per instructions packed with the case.

- Remove the corrugated stiffener and the outdoor protective panel. Use the slit in the outdoor panel as a handhold and push out.

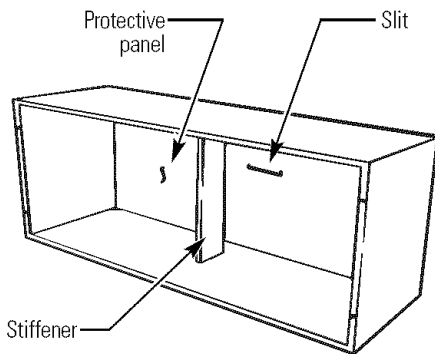

- Install the exterior grille from the room side following instructions packed with the grill.

#### Insulated Wall Case

This unit is designed to be installed in a GE plastic or an insulated steel wall case. This minimizes condensation from forming on the room side of the case.

The RAB71 series wall cases are insulated. Insulation kit RAK901L is available for use with RAB77 or existing uninsulated wall cases when needed.

**NOTE:** For installation with a subbase or duct adapter; see the instructions packed with those kits.

### 2 PREPARE THE ROOM CABINET

- Carefully remove shipping tape, if there is any, from the room cabinet and vent door.

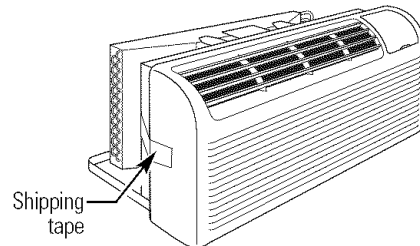

- Remove the shipping screw/clamp from the top of the vent door, if present.

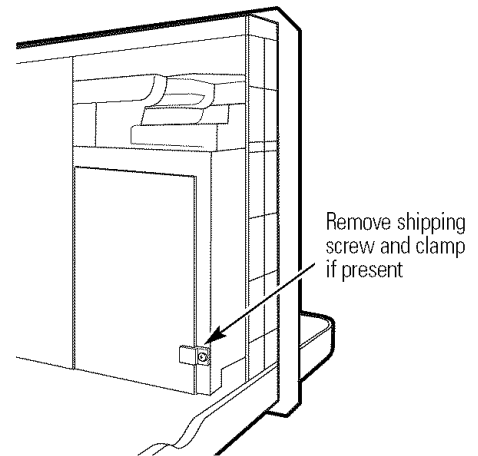

- Remove the room cabinet by pulling it out at the bottom to release it (1), then lift it up to clear the rail along the unit top (2).

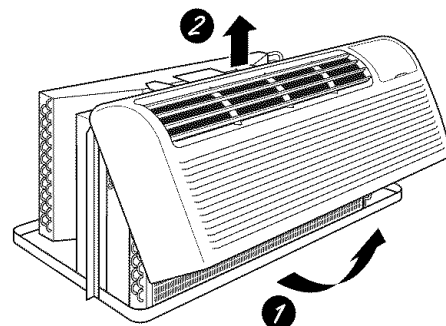

# Installation Instructions

## 3 INSTALL THE UNIT INTO THE WALL CASE

Slide the unit into the wall case and secure with four screws through the unit flange holes.

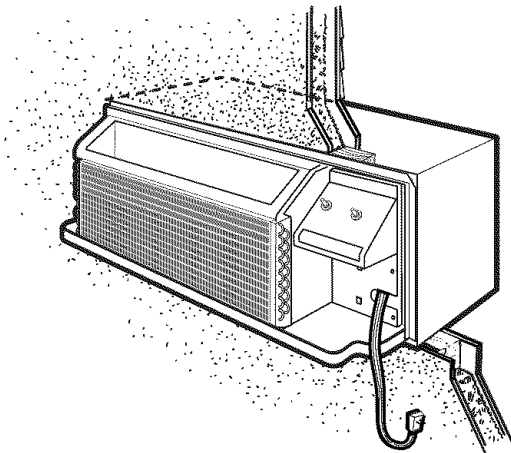

## 4 REPLACE THE ROOM CABINET

Reinstall the room cabinet by hooking the top over the rail along the unit top (1), then pushing it in at the bottom (2).

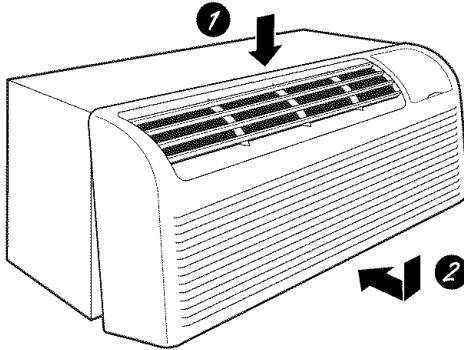

# Installation Instructions

## OPTIONAL – DRAIN KIT INSTALLATION

Dry Air 2500 Series models are designed to improve dehumidification by 25%. Since more moisture will be removed from the air, there is a greater possibility that water will drip from the wall case than with a standard unit. To prevent this water from dripping onto external building walls, we recommend the use of RAD10 Drain Kit.

### External Drain

See the Installation Instructions in the RAD10 kit.

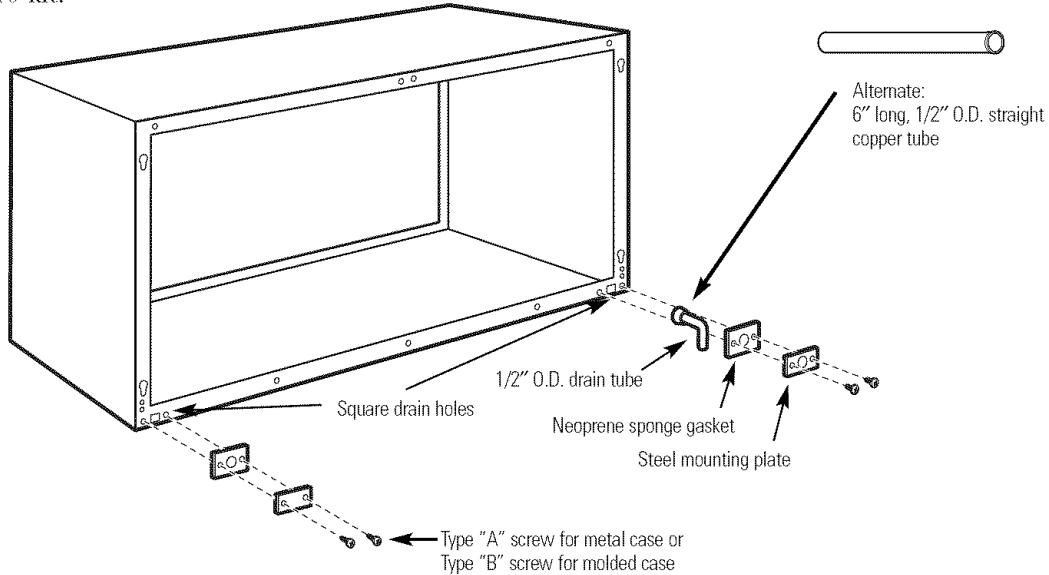

### Internal Drain

See the Installation Instructions in the RAD10 kit.

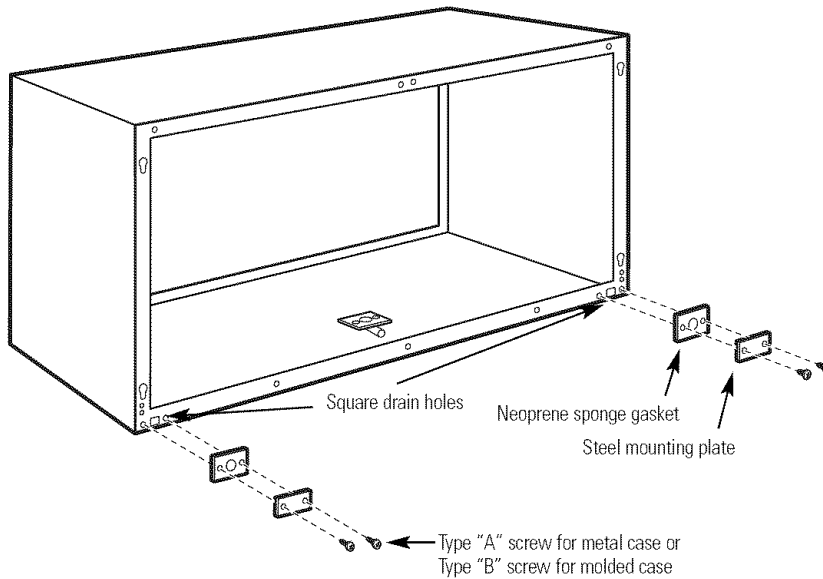

## Before You Call For Service...



### Troubleshooting Tips

Save time and money! Review the charts on the following pages first and you may not need to call for service.

Problem	Possible Causes	What To Do
<b>Zoneline does not start</b>	The unit is unplugged.	<ul style="list-style-type: none"> <li>Make sure the Zoneline plug is pushed completely into the outlet.</li> </ul>
	The fuse is blown/circuit breaker is tripped.	<ul style="list-style-type: none"> <li>Check the house fuse/circuit breaker box and replace the fuse or reset the breaker.</li> </ul>
	The unit is waiting for the compressor overload protector to reset.	<ul style="list-style-type: none"> <li>This is normal. The Zoneline will start again after it resets.</li> </ul>
	Power failure.	<ul style="list-style-type: none"> <li>If power failure occurs, set the mode control to <b>STOP</b>. When power is restored, set the mode control to the desired setting.</li> <li>There is a protective time delay (up to 3 minutes) to prevent tripping of the compressor overload. For this reason, the unit may not start normal heating or cooling for 3 minutes after it is turned back on.</li> </ul>
<b>Zoneline does not cool or heat as it should</b>	Indoor airflow is restricted.	<ul style="list-style-type: none"> <li>Make sure there are no curtains, blinds or furniture blocking the front of the Zoneline.</li> </ul>
	Outdoor airflow is restricted or recirculated.	<ul style="list-style-type: none"> <li>Make sure the rear grille is not restricted. This can cause the unit to cycle off due to the compressor overload.</li> <li>Outdoor grille must have a minimum of 65% free area. Non-GE grilles may be too restrictive for proper performance. Consult your salesperson for assistance.</li> </ul>
	The temp control may not be set high enough.	<ul style="list-style-type: none"> <li>Turn the control to a lower or higher setting. <b>NOTE:</b> The temperature limiter may be limiting the temperature range.</li> </ul>
	The air filter is dirty.	<ul style="list-style-type: none"> <li>Clean the filter at least every 30 days. See the <i>Operating Instructions</i> section.</li> </ul>
	The room may have been hot or cold.	<ul style="list-style-type: none"> <li>When the Zoneline is first turned on you need to allow time for the room to cool down or warm up.</li> </ul>
	Outdoor air is entering the room.	<ul style="list-style-type: none"> <li>Set the vent control to the <b>CLOSE</b> position.</li> </ul>
<b>Burning odor at the start of heating operation</b>	Dust is on the surface of the heating element.	<ul style="list-style-type: none"> <li>This can cause a "burning" odor at the beginning of the heating operation. This odor should quickly fade.</li> </ul>
<b>The air is not always cool or hot during operation</b>	The heat pump is not producing hot air.	<ul style="list-style-type: none"> <li>This is normal. The heat pump will produce warm air but not as hot as air produced when the higher-cost electric heat is used.</li> </ul>
	The fan switch may be set at continuous fan	<ul style="list-style-type: none"> <li>This causes the fan to blow room temperature air even when the compressor or heater cycles off. The continuous air movement provides better overall temperature control.</li> </ul>
<b>The air does not feel warm enough during heating operation</b>	The heat pump alone produces air that feels cooler than desired.	<ul style="list-style-type: none"> <li>Use the Electric Heat Option. This turns off the heat pump and warms with electric heat only. <b>NOTE:</b> Use of this option will result in increased energy consumption.</li> </ul>

**Normal Operating Sounds**



You may hear a pinging noise caused by water being picked up and thrown against the condenser on rainy days or when the humidity is high. This design feature helps remove moisture and improve efficiency.

**"CLICK"**

You may hear relays click when the controls cycle on and off or are adjusted to change the room temperature.



Water will collect in the base pan during high humidity or on rainy days. The water may overflow and drip from the outdoor side of the unit.



The indoor fan runs continuously when the unit is operating in the cooling mode, unless the fan switch behind the room cabinet is set at fan cycle (up). This will cause the fan to cycle on and off with the compressor. You may also hear a fan noise stop and start.

**3-Minute Delay**

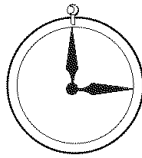

You may notice a few minutes delay in starting if you try to restart the Zoneline too soon after turning it off or if you adjust the thermostat right after the compressor has shut off. This is due to a built-in restart protector for the compressor that causes a 3-minute delay.

**SILENCE**

The compressor shuts off during the defrost cycle. Full resistance heat comes on during the defrost cycle to maintain room comfort.

**COMPRESSOR PROTECTION**

To protect the compressor and prevent short cycling, the unit is designed to run for a minimum of 3 minutes, after the compressor starts at any thermostat setting.

<i>Customer Service</i>	<i>Troubleshooting Tips</i>	<i>Care and Cleaning</i>	<i>Operating Instructions</i>	<i>Safety Instructions</i>
-------------------------	-----------------------------	--------------------------	-------------------------------	----------------------------

**Notes.**

---

**Notes.**

---

<i>Safety Instructions</i>	<i>Operating Instructions</i>	<i>Care and Cleaning</i>	<i>Troubleshooting Tips</i>	<i>Customer Service</i>
----------------------------	-------------------------------	--------------------------	-----------------------------	-------------------------

<i>Customer Service</i>	<i>Troubleshooting Tips</i>	<i>Care and Cleaning</i>	<i>Operating Instructions</i>	<i>Safety Instructions</i>
-------------------------	-----------------------------	--------------------------	-------------------------------	----------------------------

**Notes.**

---



 Cut here

Please place in envelope and mail to:

***General Electric Company***  
**Warranty Registration Department**  
**P.O. Box 32150**  
**Louisville, KY 40232-2150**



# Zonline Warranty.



All warranty service provided by our Factory Service Centers, or an authorized Customer Care<sup>®</sup> technician. To schedule service, on-line, 24 hours a day, visit us at [www.GEAppliances.com](http://www.GEAppliances.com), or call 800.GE.CARES (800.432.2737). For service in Canada, call 1.800.361.3400.

Staple your receipt here. Proof of the original purchase date is needed to obtain service under the warranty.

For The Period Of:	GE Will Replace:
<b>One Year</b> From the date of the original purchase	<b>Any part</b> of the Zonline which fails due to a defect in materials or workmanship. During this <b>full one-year warranty</b> , GE will also provide, <b>free of charge</b> , all labor and on-site service to replace the defective part.
<b>Five Years</b> From the date of the original purchase	<b>Any part of the sealed refrigerating system</b> (the compressor, condenser, evaporator and all connecting tubing) which fails due to a defect in materials or workmanship. During this <b>full five-year sealed refrigerating system warranty</b> , GE will also provide, <b>free of charge</b> , all labor and on-site service to replace the defective part.
<b>Five Years</b> From the date of the original purchase	For the <b>second through the fifth year</b> from the date of original purchase, GE will replace <b>certain parts</b> that fail due to a defect in materials or workmanship. Parts covered are fan motors, switches, thermostats, heater, heater protectors, compressor overload, solenoids, circuit boards, auxiliary controls, thermistors, frost controls, ICR pump, capacitors, varistors and indoor blower bearing. During this <b>limited four-year parts warranty</b> , you will be responsible for any labor or on-site service costs.

## What GE Will Not Cover:

- Service trips to your site to teach you how to use the product.
- Improper installation.  
If you have an installation problem, or if the air conditioner is of improper cooling capacity for the intended use, contact your dealer or installer. You are responsible for providing adequate electrical connecting facilities.
- In commercial locations, labor necessary to move the unit to a location where it is accessible for service by an individual technician.
- Failure or damage resulting from corrosion due to installation in an environment containing corrosive chemicals.
- Replacement of fuses or resetting of circuit breakers.
- Failure of the product resulting from modifications to the product or due to unreasonable use including failure to provide reasonable and necessary maintenance.
- Failure or damage resulting from corrosion due to installation in a coastal environment, except for models treated with special factory-applied anti-corrosion protection as designated in the model number.
- Damage to product caused by improper power supply voltage, accident, fire, floods or acts of God.
- Incidental or consequential damage to personal property caused by possible defects with this air conditioner.

This warranty is extended to the original purchaser and any succeeding owner for products purchased for use within the USA and Canada. In Alaska, the warranty excludes the cost of shipping or service calls to your site.

Some states or provinces do not allow the exclusion or limitation of incidental or consequential damages. This warranty gives you specific legal rights, and you may also have other rights which vary from state to state or province to province. To know what your legal rights are, consult your local, state or provincial consumer affairs office or your state's Attorney General.

Warrantor: General Electric Company, Louisville, KY 40225

Safety Instructions

Operating Instructions

Care and Cleaning

Troubleshooting Tips

Customer Service

## Consumer Support.

---



### *GE Appliances Website*

[www.GEAppliances.com](http://www.GEAppliances.com)

---

Have a question or need assistance with your appliance? Try the GE Appliances Website 24 hours a day, any day of the year! For greater convenience and faster service, you can now download Owner's Manuals, order parts, catalogs, or even schedule service on-line. You can also "Ask Our Team of Experts™" your questions, and so much more...

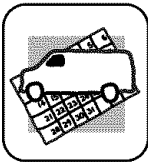

### *Schedule Service*

[www.GEAppliances.com](http://www.GEAppliances.com)

---

Expert GE repair service is only one step away from your door. Get on-line and schedule your service at your convenience 24 hours any day of the year! Or call 800.GE.CARES (800.432.2737) during normal business hours.

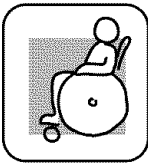

### *Real Life Design Studio*

[www.GEAppliances.com](http://www.GEAppliances.com)

---

GE supports the Universal Design concept—products, services and environments that can be used by people of all ages, sizes and capabilities. We recognize the need to design for a wide range of physical and mental abilities and impairments. For details of GE's Universal Design applications, including kitchen design ideas for people with disabilities, check out our Website today. For the hearing impaired, please call 800.TDD.GEAC (800.833.4322).

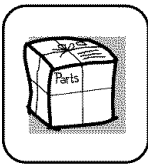

### *Parts and Accessories*

[www.GEAppliances.com](http://www.GEAppliances.com)

---

Individuals qualified to service their own appliances can have parts or accessories sent directly to their homes (VISA, MasterCard and Discover cards are accepted). Order on-line today, 24 hours every day or by phone at 800.626.2002 during normal business hours.

***Instructions contained in this manual cover procedures to be performed by any user. Other servicing generally should be referred to qualified service personnel. Caution must be exercised, since improper servicing may cause unsafe operation.***



### *Contact Us*

[www.GEAppliances.com](http://www.GEAppliances.com)

---

If you are not satisfied with the service you receive from GE, contact us on our Website with all the details including your phone number, or write to: General Manager, Customer Relations  
GE Appliances, Appliance Park  
Louisville, KY 40225



### *Register Your Appliance*

[www.GEAppliances.com](http://www.GEAppliances.com)

---

Register your new appliance on-line—at your convenience! Timely product registration will allow for enhanced communication and prompt service under the terms of your warranty, should the need arise. You may also mail in the pre-printed registration card included in the packing material, or detach and use the form in this Owner's Manual.