

# ***Multi Channel AV Receiver***

---

Operating Instructions

## **Owner's Record**

The model and serial numbers are located on the rear of the unit. Record the serial number in the space provided below. Refer to them whenever you call upon your Sony dealer regarding this product.

Model No. \_\_\_\_\_ Serial No. \_\_\_\_\_

***STR-DG800***

## WARNING

### To reduce the risk of fire or electric shock, do not expose this apparatus to rain or moisture.

To prevent fire, do not cover the ventilation of the apparatus with newspapers, table-cloths, curtains, etc. And don't place lighted candles on the apparatus.

To prevent fire or shock hazard, do not place objects filled with liquids, such as vases, on the apparatus.

Do not install the appliance in a confined space, such as a bookcase or built-in cabinet.

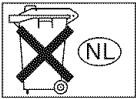

Don't throw away batteries with general house waste; dispose of them correctly as chemical waste.

## For customers in the United States

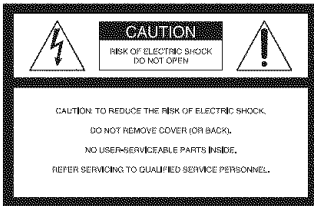

This symbol is intended to alert the user to the presence of uninsulated "dangerous voltage" within the product's enclosure that may be of sufficient magnitude to constitute a risk of electric shock to persons.



This symbol is intended to alert the user to the presence of important operating and maintenance (servicing) instructions in the literature accompanying the appliance.

## WARNING

This equipment has been tested and found to comply with the limits for a Class B digital device, pursuant to Part 15 of the FCC Rules. These limits are designed to provide reasonable protection against harmful interference in a residential installation.

This equipment generates, uses, and can radiate radio frequency energy and, if not installed and used in accordance with the instructions, may cause harmful interference to radio communications.

However, there is no guarantee that interference will not occur in a particular installation. If this equipment does cause harmful interference to radio or television reception, which can be determined by turning the equipment off and on, the user is encouraged to try to correct the interference by one or more of the following measures:

- Reorient or relocate the receiving antenna.
- Increase the separation between the equipment and receiver.
- Connect the equipment into an outlet on a circuit different from that to which the receiver is connected.
- Consult the dealer or an experienced radio/TV technician for help.

## CAUTION

You are cautioned that any changes or modification not expressly approved in this manual could void your authority to operate this equipment.

## Note to CATV system installer:

This reminder is provided to call CATV system installer's attention to Article 820-40 of the NEC that provides guidelines for proper grounding and, in particular, specifies that the cable ground shall be connected to the grounding system of the building, as close to the point of cable entry as practical.

# About This Manual

- The instructions in this manual are for model STR-DG800. Check your model number by looking at the lower right corner of the front panel. In this manual, models of area code U is used for illustration purposes unless stated otherwise. Any difference in operation is clearly indicated in the text, for example, “Models of area code CA only”.
- The instructions in this manual describe the controls on the supplied remote. You can also use the controls on the receiver if they have the same or similar names as those on the remote.

## About area codes

The area code of the receiver you purchased is shown on the lower left portion of the rear panel (see the illustration below).

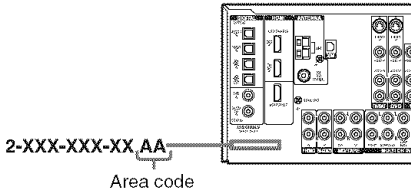

Any differences in operation, according to the area code, are clearly indicated in the text, for example, “Models of area code AA only”.

This receiver incorporates Dolby<sup>®</sup> Digital and Pro Logic Surround and the DTS<sup>®</sup> Digital Surround System.

- \* Manufactured under license from Dolby Laboratories. “Dolby”, “Pro Logic”, “Surround EX”, and the double-D symbol are trademarks of Dolby Laboratories.
- \*\* “DTS”, “DTS-ES”, “Neo:6”, and “DTS 96/24” are trademarks of Digital Theater Systems, Inc.

This receiver incorporates High-Definition Multimedia Interface (HDMI<sup>™</sup>) technology. HDMI, the HDMI logo and High-Definition Multimedia Interface are trademarks or registered trademarks of HDMI Licensing LLC.

XM is a registered trademark of XM Satellite Radio Inc.

---

# Table of Contents

---

## Getting Started

Description and location of parts.....	5
1: Installing speakers .....	15
2: Connecting speakers .....	16
3a: Connecting the audio components.....	17
3b: Connecting the video components .....	23
4: Connecting the antennas.....	32
5: Preparing the receiver and the remote .....	33
6: Selecting the speaker system.....	35
7: Calibrating the appropriate settings automatically (AUTO CALIBRATION).....	35
8: Adjusting the speaker levels and balance (TEST TONE).....	39

---

## Playback

Selecting a component.....	40
Listening/Watching a component .....	42

---

## Amplifier Operations

Navigating through menus.....	46
Adjusting the level (LEVEL menu).....	51
Adjusting the equalizer (EQ menu) .....	52
Settings for the surround sound (SUR menu).....	52
Settings for the tuner (TUNER menu).....	54
Settings for the audio (AUDIO menu).....	55
Settings for the video (VIDEO menu).....	56
Settings for the system (SYSTEM menu) .....	56
Calibrating the appropriate settings automatically (AUTO CAL menu).....	60

---

## Enjoying Surround Sound

Enjoying Dolby Digital and DTS Surround sound (AUTO FORMAT DIRECT) .....	61
Selecting a pre-programmed sound field.....	63

Using only the front speakers (2CH STEREO) .....	66
Listening to the sound without any adjustment (ANALOG DIRECT).....	66
Resetting sound fields to the initial settings .....	67

---

## Tuner Operations

Listening to FM/AM radio.....	67
Presetting radio stations .....	69
Listening to the XM Radio .....	72
Presetting XM Radio stations .....	76

---

## Other Operations

Switching the audio input mode (INPUT MODE) .....	78
Listening to digital sound from other inputs (DIGITAL ASSIGN) .....	78
Watching component images from other inputs (COMPONENT VIDEO ASSIGN).....	80
Watching HDMI images from other inputs (HDMI VIDEO ASSIGN) .....	81
Naming inputs.....	82
Changing the display .....	83
Using the Sleep Timer .....	83
Recording using the receiver.....	84
Listening to the sound in another zone .....	85

---

## Using the Remote

Programming the remote .....	86
------------------------------	----

---

## Additional Information

Glossary .....	91
Precautions .....	92
Troubleshooting .....	93
Specifications .....	97
Index .....	100

# Description and location of parts

## Front panel

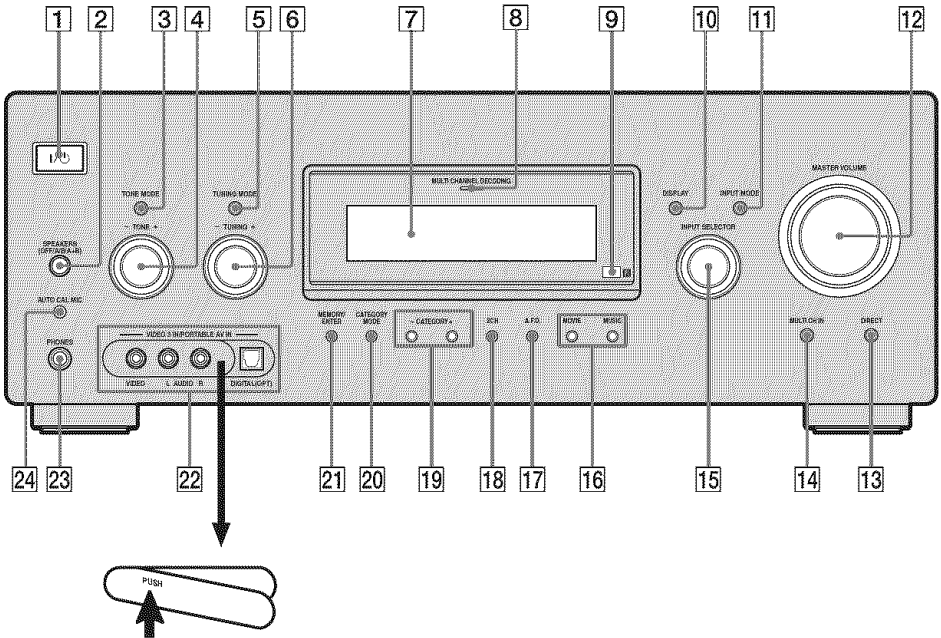

### To remove the cover

Press PUSH.

When you remove the cover, keep it out of reach from children.

Name	Function
1 I/⏻	Press to turn the receiver on or off (page 33, 42, 43, 67, 98).
2 <b>SPEAKERS (OFF/A/B/A+B)</b>	Press to select OFF, A, B, A+B of the front speakers (page 35).
3 <b>TONE MODE</b>	Press to select Equalizer mode (page 47).
4 <b>TONE +/-</b>	Turn to adjust the EQUALIZER menu parameters (page 47, 52).
5 <b>TUNING MODE</b>	Press to select the tuning mode (page 71, 98).
6 <b>TUNING +/-</b>	Turn to scan a station (page 68, 70).

continued

Name	Function
<b>7 Display</b>	The current status of the selected component or a list of selectable items appears here (page 7).
<b>8 MULTI CHANNEL DECODING lamp</b>	Lights up when multi channel audio is decoded (page 43).
<b>9 Remote sensor</b>	Receives signals from remote commander.
<b>10 DISPLAY</b>	Press to select information displayed on the display (page 82).
<b>11 INPUT MODE</b>	Press to select the input mode when the same components are connected to both digital and analog jacks (page 78).
<b>12 MASTER VOLUME</b>	Turn to adjust the volume level of all speakers at the same time (page 39, 40, 42, 43).
<b>13 DIRECT</b>	Press to listen to high quality analog sound (page 66).
<b>14 MULTI CH IN</b>	Press to select the audio directly from the components connected to the MULTI CH IN jacks (page 40).
<b>15 INPUT SELECTOR</b>	Turn to select the input source to playback (page 40, 42, 43, 66, 68, 71, 78, 82, 83).
<b>16 MOVIE, MUSIC</b>	Press to select sound fields for movie or music (page 63).
<b>17 A.F.D.</b>	Press to select A.F.D. mode (page 61).
<b>18 2CH</b>	Press to select 2CH STEREO mode (page 66, 67).

Name	Function
<b>19 CATEGORY +/-</b>	Press to select a category (page 75).
<b>20 CATEGORY MODE</b>	Press to select the category mode (page 74).
<b>21 MEMORY/ ENTER</b>	Press to store a station or enter the selection when selecting the settings (page 33).
<b>22 VIDEO 3 IN/ PORTABLE AV IN jacks</b>	To connect a camcorder or video game (page 29, 40).
<b>23 PHONES jack</b>	Connects to a headphone (page 94).
<b>24 AUTO CAL MIC jack</b>	Connects to the supplied ECM-AC2 optimizer microphone for the Auto Calibration function (page 35).

## About the indicators on the display

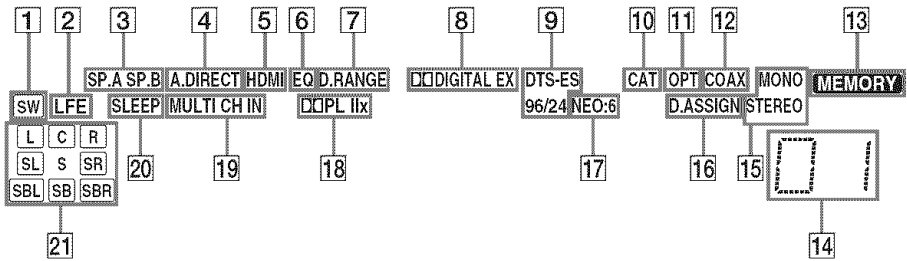

Name	Function
<b>1</b> SW	Lights up when sub woofer selection is set to "YES" (page 49) and the audio signal is output from the SUB WOOFER jack.
<b>2</b> LFE	Lights up when the disc being played back contains an LFE (Low Frequency Effect) channel and the LFE channel signal is actually being reproduced.
<b>3</b> SP.A/SP.B	Lights up according to the speaker system used. However, these indicators do not light up if the speaker output is turned off or if a headphone is connected.
<b>4</b> A.DIRECT	Lights up when ANALOG DIRECT is selected (page 66).
<b>5</b> HDMI	Flashes when you select "HDMI V. ASSIGN" in the Video menu (page 81).
<b>6</b> EQ	Lights up when the equalizer is activated (page 47).
<b>7</b> D.RANGE	Lights up when dynamic range compression is activated (page 47).

Name	Function
<b>8</b> DIGITAL EX	Lights up when Dolby Digital signals are input. "DIGITAL EX" lights up when Dolby Digital Surround EX signals are decoded. <b>Note</b> When playing a Dolby Digital format disc, be sure that you have made digital connections and that INPUT MODE is not set to "ANALOG FIXED" (page 78).
<b>9</b> DTS (-ES)/ (96/24)	Lights up when DTS signals are input. "DTS-ES" lights up when DTS-ES signals are input. "DTS 96/24" lights up when the receiver is decoding DTS 96 kHz/24 bit signals. <b>Note</b> When playing a DTS format disc, be sure that you have made digital connections and that INPUT MODE is not set to "ANALOG FIXED" (page 78).
<b>10</b> CAT	Lights up when you select category mode to "ONE CAT". For details on presetting XM Radio station, see page 76.
<b>11</b> OPT	Lights up when INPUT MODE is set to "AUTO 2CH" and the source signal is a digital signal being input through the OPTICAL jack, or when INPUT MODE is set to "OPT FIXED" (page 78).

Name	Function
<b>12 COAX</b>	Lights up when INPUT MODE is set to "AUTO 2CH" and the source signal is a digital signal being input through the COAXIAL jack, or when INPUT MODE is set to "COAX FIXED" (page 78).
<b>13 MEMORY</b>	Lights up when a memory function, such as Preset Memory (page 70), etc., is activated.
<b>14 Preset station indicators</b>	Lights up when using the receiver to tune in radio stations you have preset. For details on presetting radio stations, see page 69.
<b>15 Tuner indicators</b>	Lights up when using the receiver to tune in radio stations (page 67), etc.
<b>16 D.ASSIGN</b>	Lights up when the digital assign function is used for selected input.
<b>17 NEO:6</b>	Lights up when DTS Neo:6 Cinema/Music decoder is activated (page 62).
<b>18 DOLBY PL (II)/(IIx)</b>	Lights up when the receiver applies Pro Logic processing to 2 channel signals in order to output the center and surround channel signals. "DOLBY PL II" lights up when the Pro Logic II Movie/Music/Game decoder is activated. "DOLBY PL IIx" lights up when the Pro Logic IIx Movie/Music/Game decoder is activated. However, these indicators do not light up if both the center and surround speakers are set to "NO" (page 49) and you select a sound field using the A.F.D. button. <b>Note</b> Dolby Pro Logic IIx decoding does not function for DTS format signals or for signals with a sampling frequency of more than 48 kHz.
<b>19 MULTI CH IN</b>	Lights up when MULTI CH IN is selected (page 40).
<b>20 SLEEP</b>	Lights up when the sleep timer is activated (page 83).

Name	Function
<b>21 Playback channel indicators</b>	The letters (L, C, R, etc.) indicate the channels being played back. The boxes around the letters vary to show how the receiver downmixes the source sound (based on the speaker settings).
<b>L</b>	Front Left
<b>R</b>	Front Right
<b>C</b>	Center (monaural)
<b>SL</b>	Surround Left
<b>SR</b>	Surround Right
<b>S</b>	Surround (monaural or the surround components obtained by Pro Logic processing)
<b>SBL</b>	Surround back left
<b>SBR</b>	Surround back right
<b>SB</b>	Surround back (the surround back components obtained by 6.1 channel decoding)
	<b>Example:</b> Recording format (Front/ Surround): 3/2.1 Output channel: When surround speaker is set to "NO" (page 49) Sound Field: A.F.D. AUTO



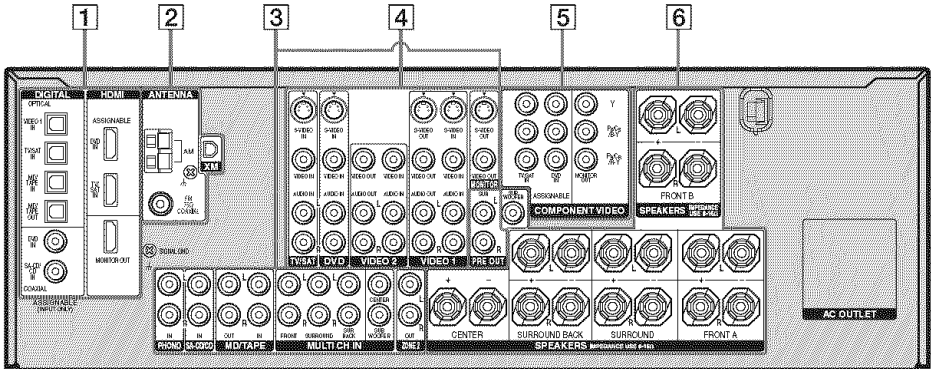

## 1 DIGITAL INPUT/OUTPUT section



**OPTICAL IN/OUT jack** Connects to a DVD player, etc. The COAXIAL jack provides a better quality of loud sound (page 26, 28).



**COAXIAL IN jack**



**HDMI IN/MONITOR OUT jack** Connects to a DVD player, or a satellite tuner. The image and the sound are output to TV or a projector (page 30).

## 2 ANTENNA section



**FM ANTENNA** Connects to the FM wire antenna supplied with this receiver (page 32).



**AM ANTENNA** Connects to the AM loop antenna supplied with this receiver (page 32).



**XM** Connects to the XM connect-and-play antenna (not supplied with this receiver) (page 72).

## 3 AUDIO INPUT/OUTPUT section



**White (L) AUDIO IN/OUT jack** Connects to an MD deck or CD player, etc. (page 21).



**Red (R)**



**White (L) MULTI CHANNEL INPUT jack** Connects to a Super Audio CD player or DVD player which has an analog audio jack for 7.1 channel sound (page 20).



**Red (R)**



**Black**



**White (L) PRE OUT jack** Connects to an external power amplifier.



**Red (R)**

## 4 VIDEO/AUDIO INPUT/OUTPUT section



**White (L) VIDEO/AUDIO IN/OUT jack** Connects the video and audio jacks of a VCR or a DVD player (page 25, 26, 27, 28, 29).



**Red (R)**





**Yellow VIDEO IN/OUT jack\***



**S-VIDEO IN/OUT jack\***

## 5 COMPONENT VIDEO INPUT/OUTPUT section

-  Green COMPONENT VIDEO INPUT/OUTPUT jack\* Connects to a DVD player, TV, or a satellite tuner. You can enjoy high quality image (page 25, 27, 28).
-  Blue COMPONENT VIDEO INPUT/OUTPUT jack\*
-  Red COMPONENT VIDEO INPUT/OUTPUT jack\*

## 6 SPEAKER section

-  Connects to speakers (page 16).

-  Connects to sub woofer (page 16).

\* You can watch the selected input image when you connect the MONITOR OUT jack to a TV monitor (page 25).

## Remote commander

You can use the supplied remote to operate the receiver and to control the Sony audio/video components that the remote is assigned to operate. You can also program the remote to control non-Sony audio/video components. For details, see "Programming the remote" (page 86).

### RM-AAP008

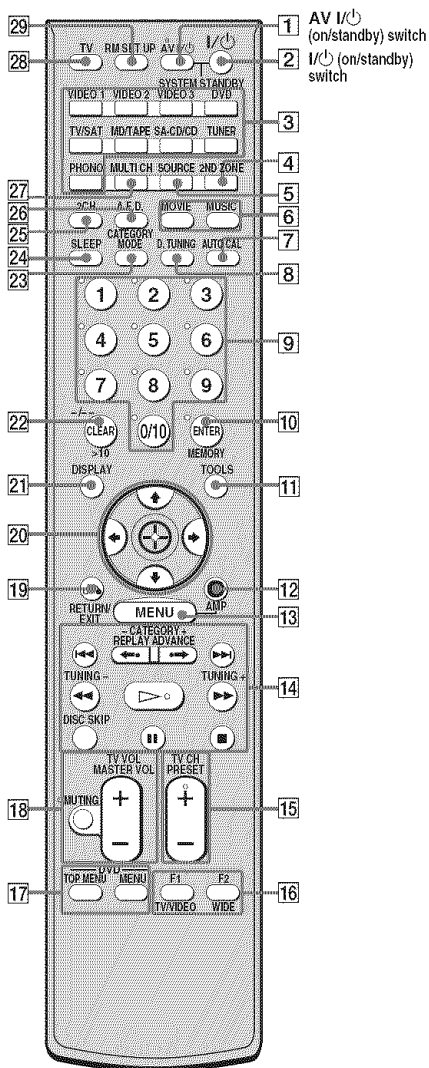

Name	Function
<b>1</b> AV I/⏻	<p>Press to turn on or off the Sony audio/video components that the remote is programmed to operate.</p> <p>To turn the TV on or off, press TV (28) and then press AV I/⏻.</p> <p>If you press I/⏻ (2) at the same time, it will turn off the receiver and other components (SYSTEM STANDBY).</p> <p><b>Note</b></p> <p>The function of the AV I/⏻ switch changes automatically each time you press the input buttons (3).</p>
<b>2</b> I/⏻	<p>Press to turn the receiver on or off.</p> <p>To turn off all components, press I/⏻ and AV I/⏻ (1) at the same time (SYSTEM STANDBY).</p>

Name	Function
<b>3</b> Input buttons	<p>Press one of the buttons to select the component you want to use. When you press any of the input buttons, the receiver turns on. The buttons are factory assigned to control Sony components as follows. You can program the remote to control non-Sony components by changing the code. For details see "Programming the remote" (page 86).</p>





Button	Assigned Sony component
VIDEO 1	VCR (VTR mode 3)
VIDEO 2	VCR (VTR mode 2)
VIDEO 3	VCR (VTR mode 1)
DVD	DVD player
TV/SAT	TV tuner
MD/TAPE	MD deck
SA-CD/CD	Super Audio CD/CD player
TUNER	Built-in tuner
PHONO	Not assigned.

<b>4</b> 2ND ZONE	Press 2ND ZONE to light up the button to select the command mode of the remote.
<b>5</b> SOURCE	Press to select the current input for the main receiver.
<b>6</b> MOVIE, MUSIC	Press to select sound fields (MOVIE, MUSIC).
<b>7</b> AUTO CAL	Press to activate the Auto Calibration function.
<b>8</b> D.TUNING	Press to enter direct tuning mode.

Name	Function
<b>9</b> <b>Numeric buttons (number 5<sup>a</sup>)</b>	<p>Press to</p> <ul style="list-style-type: none"> <li>– preset/tune to preset stations.</li> <li>– select track numbers of the CD player, DVD player, LD player, DAT deck, tape deck or MD deck. Press 0/10 to select track number 10.</li> <li>– select channel numbers of the VCR, satellite tuner, Blu-ray disc recorder, PSX, DVD/VIDEO COMBO, or DVD/HDD COMBO.</li> </ul> <p>Press TV (<b>28</b>), and then press the numeric buttons to select the TV channels.</p>
<b>10</b> <b>ENTER</b>	<p>Press to enter the value after selecting a channel, disc or track using the numeric buttons.</p> <p>To enter the value of Sony TV, press TV (<b>28</b>), and then press ENTER.</p>
<b>MEMORY</b>	Press to store a station.
<b>11</b> <b>TOOLS</b>	<p>Press to display options applicable to the entire disc (e.g. disc protection), recorder (e.g. audio settings during recording), or multiple items on a list menu (e.g. erasing multiple titles).</p> <p>To display the options of Sony TV, press TV (<b>28</b>), and then press TOOLS.</p>
<b>12</b> <b>AMP</b>	Press AMP to light up the button, then press MENU ( <b>13</b> ) to display the menu of the receiver. Then, use the control buttons to perform menu operations.
<b>13</b> <b>MENU</b>	<p>Press to display the menus of the VCR, DVD player, satellite tuner, Blu-ray disc recorder, PSX, DVD/VIDEO COMBO, or DVD/HDD COMBO, on the TV screen. Then, use the control buttons to perform menu operations.</p> <p>To display the menus of Sony TV, press TV (<b>28</b>), and then press MENU.</p>

Name	Function
<b>14</b>	Press to skip tracks of the VCR, CD player, VCD player, LD player, DVD player, MD deck, DAT deck, tape deck, Blu-ray disc recorder, PSX, DVD/VIDEO COMBO, or DVD/HDD COMBO.
<b>REPLAY</b> <b>ADVANCE</b>	Press to replay the previous scene or fast forward the current scene of the VCR, DVD player, DVD/VIDEO COMBO, or DVD/HDD COMBO.
<b>CATEGORY</b> <b>+/-</b>	Press to select XM Radio category you want.
	<p>Press to</p> <ul style="list-style-type: none"> <li>– search tracks in the forward/backward direction of the DVD player, LD player, MD deck, Blu-ray disc recorder, PSX, DVD/VIDEO COMBO, or DVD/HDD COMBO.</li> <li>– fast forward/rewind of the VCR, CD player, MD deck, DAT deck or tape deck.</li> </ul>
	Press to start playback of the VCR, CD player, VCD player, LD player, DVD player, MD deck, tape deck, Blu-ray disc recorder, PSX, DVD/VIDEO COMBO, or DVD/HDD COMBO.
<b>DISC SKIP</b>	Press to skip disc of the CD player, VCD player, DVD player, MD deck or LD player (multi-disc changer only).
<b>II</b>	Press to pause playback or recording of the VCR, CD player, VCD player, LD player, DVD player, MD deck, DAT deck, tape deck, Blu-ray disc recorder, PSX, DVD/VIDEO COMBO, or DVD/HDD COMBO. (Also starts recording with components in recording standby.)

Name	Function
<b>14</b> ■	Press to stop playback of the VCR, CD player, VCD player, LD player, DVD player, MD deck, DAT deck, tape deck, Blu-ray disc recorder, PSX, DVD/VIDEO COMBO, or DVD/HDD COMBO.
<b>TUNING +/-</b>	Press to scan a station.
<b>15</b> <b>TV CH +<sup>a</sup>/-</b>	Press TV (28), and then press TV CH +/- to select preset TV channels.
<b>PRESET +<sup>a</sup>/-</b>	Press to select – preset stations. – preset channels of the VCR, satellite tuner, Blu-ray disc recorder, DVD, DVD/VIDEO COMBO, or DVD/HDD COMBO.
<b>16</b> <b>F1, F2</b>	Press to select the media (for DVD/VIDEO COMBO and DVD/HDD COMBO models only).
<b>WIDE</b>	Press TV (28), and then press WIDE to select the wide picture mode.
<b>TV/VIDEO</b>	Press TV (28) and then press TV/VIDEO to select the input signal (TV input or video input).
<b>17</b> <b>DVD TOP MENU</b>	Press to display the DVD title of the DVD player on the TV screen. Then, use the control buttons to perform menu operations.
<b>DVD MENU</b>	Press to display the menu of the DVD player on the TV screen. Then, use the control buttons to perform menu operations.

Name	Function
<b>18</b> <b>TV VOL +/-</b>	Press TV (28) and then press TV VOL +/- to adjust the TV volume level.
<b>MASTER VOL +/-</b>	Press to adjust the volume level of all speakers at the same time.
<b>MUTING</b>	Press to mute the sound. To mute the sound of the TV, press TV (28) and then press MUTING.
<b>19</b> <b>RETURN/EXIT</b> ↶	Press to – return to the previous menu. – exit the menu while the menu or on-screen guide of the VCR, DVD player, LD player, Blu-ray disc recorder, PSX or satellite tuner is displayed on the TV screen. To return to the previous menu of Sony TV, press TV (28), and then press RETURN/EXIT ↶.
<b>20</b> <b>Control buttons</b>	After pressing AMP (12), then MENU 13 for receiver operation, DVD TOP MENU 17 or DVD MENU 17, press the control button  ,  ,  , or  to select the settings. When you press DVD TOP MENU or DVD MENU, press the control button to enter the selection.
<b>21</b> <b>DISPLAY</b>	Press to select information displayed on the TV screen of the VCR, VCD player, satellite tuner, CD player, DVD player, MD deck, Blu-ray disc recorder, PSX, DVD/VIDEO COMBO, or DVD/HDD COMBO.

Name	Function
<b>22</b> <b>-/--</b>	Press to select the channel entry mode, either one or two digits of the Blu-ray disc recorder or satellite tuner. To select the channel mode of the TV, press TV ( <b>28</b> ) and then press <b>-/--</b> .
<b>&gt;10</b>	Press to select track numbers over 10 of the VCR, satellite tuner, CD player or MD deck, tape deck, TV, Blu-ray disc recorder or PSX.
<b>CLEAR</b>	Press to – clear a mistake when you press the incorrect numeric button. – return to continuous playback, etc. of the satellite tuner, Blu-ray disc recorder, PSX, DVD/VIDEO COMBO, or DVD/HDD COMBO.
<b>23</b> <b>CATEGORY MODE</b>	Press to select the category mode for XM radio.
<b>24</b> <b>SLEEP</b>	Press to activate the Sleep Timer function and the duration which the receiver turns off automatically.
<b>25</b> <b>2CH</b>	Press to select 2CH STEREO mode.
<b>26</b> <b>A.F.D.</b>	Press to select A.F.D. mode.
<b>27</b> <b>MULTI CH</b>	Press to select the audio directly from the components connected to MULTI CH IN jacks (page 40).
<b>28</b> <b>TV</b>	Press to light up the button. It changes the remote key function to activate the buttons with orange printing. It also activate the TOOLS ( <b>11</b> ), MENU ( <b>13</b> ), RETURN/EXIT  ( <b>19</b> ), and DISPLAY ( <b>21</b> ) buttons to perform menu operations for Sony TVs only.
<b>29</b> <b>RM SET UP</b>	Press to set-up the remote.

## Notes

- Some functions explained in this section may not work depending on the model.
- The above explanation is intended to serve as an example only. Therefore, depending on the component, the above operation may not be possible or may operate differently than described.

<sup>a)</sup>The number 5, PRESET +, TV CH +, and  buttons have tactile dots. Use the tactile dots as references when operating the receiver.

# 1: Installing speakers

This receiver allows you to use a 7.1 channel system (7 speakers and one sub woofer).

## Enjoying a 5.1/7.1 channel system

To fully enjoy theater-like multi channel surround sound requires five speakers (two front speakers, a center speaker, and two surround speakers) and a sub woofer (5.1 channel).

### Example of a 5.1 channel speaker system configuration

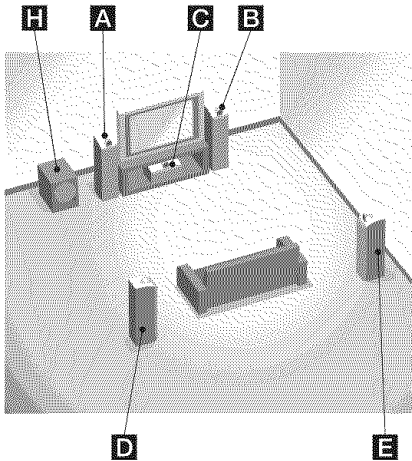

- A** Front speaker (L)
- B** Front speaker (R)
- C** Center speaker
- D** Surround speaker (L)
- E** Surround speaker (R)
- H** Sub woofer

You can enjoy high fidelity reproduction of DVD software recorded sound in the Surround EX format if you connect one additional surround back speaker (6.1 channel) or two surround back speakers (7.1 channel) (see “Using the surround back decoding mode” on page 53).

### Example of a 7.1 channel speaker system configuration

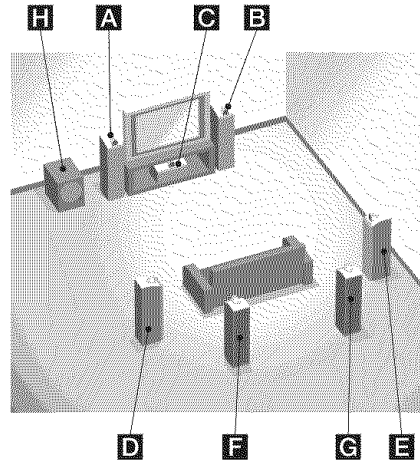

- A** Front speaker (L)
- B** Front speaker (R)
- C** Center speaker
- D** Surround speaker (L)
- E** Surround speaker (R)
- F** Surround back speaker (L)
- G** Surround back speaker (R)
- H** Sub woofer

#### Tips

- When you connect a 6.1 channel speaker system, place the surround back speaker behind the listening position.
- Since the sub woofer does not emit highly directional signals, you can place it wherever you want.
- If you connect the SUR PRE OUT jack to another power amplifier, you are recommended to connect the surround speakers to the SPEAKER jacks of that amplifier. Do not connect the surround speakers to this receiver.

## 2: Connecting speakers

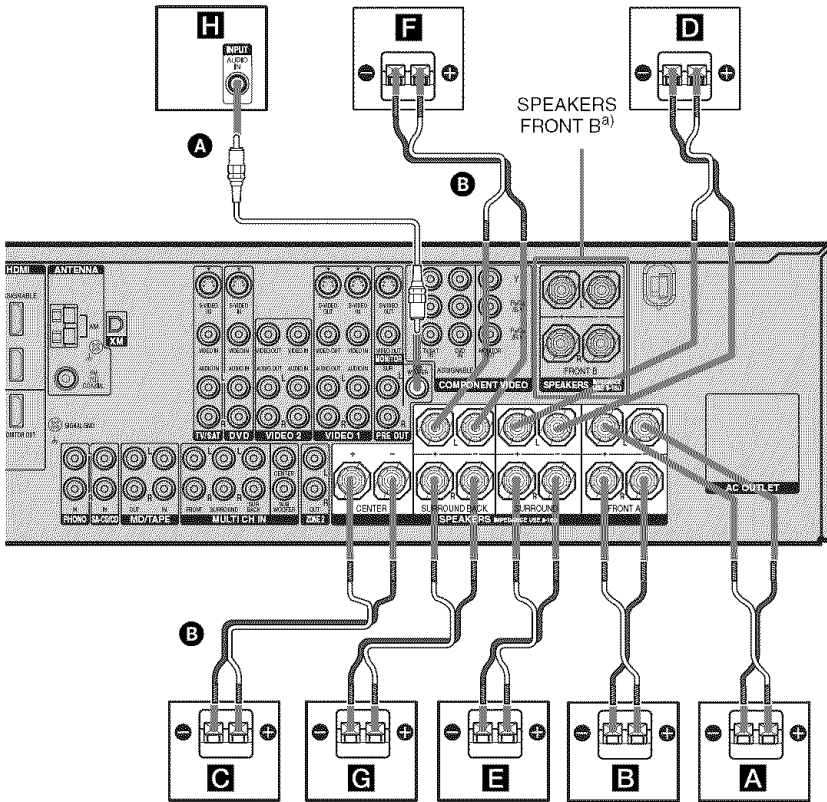

- A** Monaural audio cord (not supplied)
- B** Speaker cords (not supplied)

- A** Front speaker A (L)
- B** Front speaker A (R)
- C** Center speaker
- D** Surround speaker (L)
- E** Surround speaker (R)
- F** Surround back speaker (L)<sup>b)</sup>
- G** Surround back speaker (R)<sup>b)</sup>
- H** Sub woofer<sup>c)</sup>

<sup>a)</sup> If you have an additional front speaker system, connect them to the SPEAKERS FRONT B terminal. You can select the front speakers you want to use with the SPEAKERS (OFF/A/B/A+B) button. For details, see “6: Selecting the speaker system” (page 35).

<sup>b)</sup> If you connect only one surround back speaker, connect it to the SURROUND BACK SPEAKERS L terminal.

<sup>c)</sup> When you connect a sub woofer with an auto standby function, turn off the function when watching movies. If the auto standby function is set to ON, it turns to standby mode automatically based on the level of the input signal to a sub woofer, then sound may not be output.



## 3a: Connecting the audio components

### How to hook up your components

This section describes how to hook up your components to this receiver. Before you begin, refer to “Component to be connected” below for the pages which describe how to connect each component.

After hooking up all your components, proceed to “4: Connecting the antennas” (page 32).

### Component to be connected

Component	With	Page
Super Audio CD player/CD player	Digital audio output <sup>a)</sup>	18
	Multi-channel audio output <sup>b)</sup>	20
	Analog audio output only <sup>c)</sup>	21
MD deck/Tape deck/Turntable	Digital audio output <sup>a)</sup>	18
	Analog audio output only <sup>c)</sup>	21

<sup>a)</sup> Model with DIGITAL OPTICAL OUTPUT or DIGITAL COAXIAL OUTPUT jack etc.

<sup>b)</sup> Model with MULTI CH OUTPUT jacks, etc. This connection is used to output audio decoded by the component’s internal multi-channel decoder through this receiver.

<sup>c)</sup> Model equipped only with AUDIO OUT L/R jacks, etc.

# Connecting components with digital audio input/output jacks

The following illustration shows how to connect a Super Audio CD player/CD player and an MD deck/tape deck.

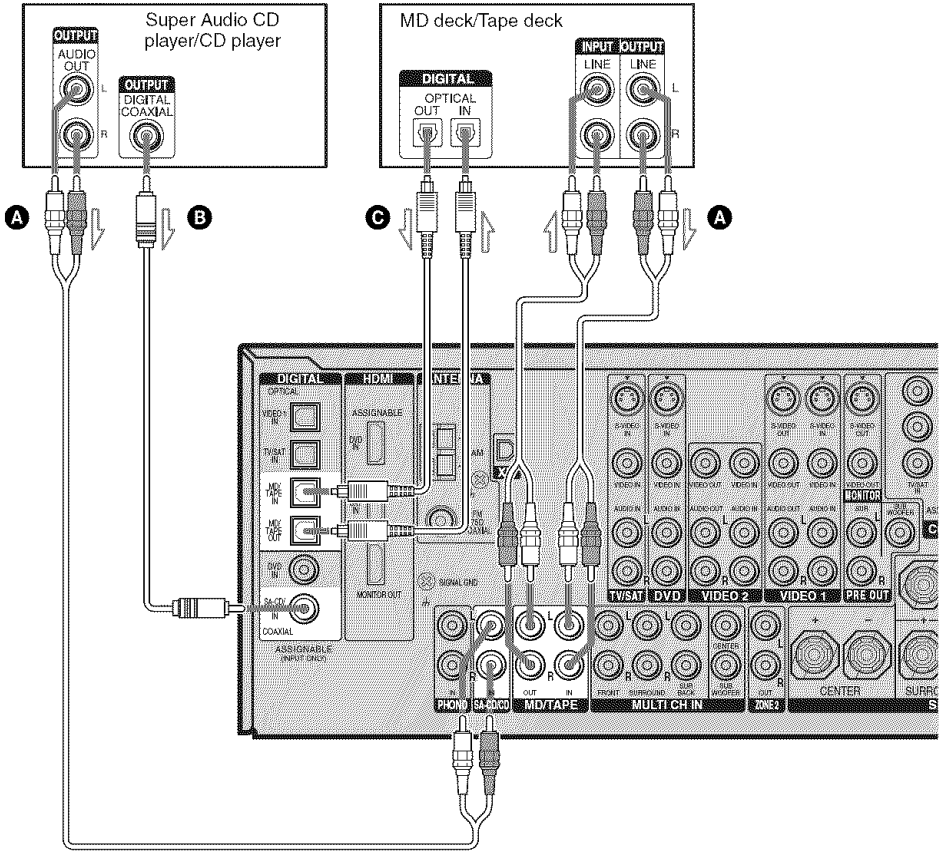

- A** Audio cord (not supplied)
- B** Coaxial digital cord (not supplied)
- C** Optical digital cord (not supplied)

## Notes on playing a Super Audio CD disc on a Super Audio CD player

- No sound is output when you play a Super Audio CD disc on a Super Audio CD player connected to only the SA-CD/CD COAXIAL IN jack on this receiver. When you play a Super Audio CD disc, connect the player to the MULTI CH IN or SA-CD/CD IN jack. Refer to the operating instructions supplied with the Super Audio CD player.
- You cannot make digital recordings if you make only analog connections. Likewise, you cannot make analog recordings if you make only digital connections. To make digital recordings, make digital connections and to make analog recordings, make analog connections.
- You cannot make digital recordings of a Super Audio CD disc. Use the analog jack for recording in this case.
- When connecting optical digital cords, insert the plugs straight in until they click into place.
- Do not bend or tie optical digital cords.

### Tip

All the digital audio jacks are compatible with 32 kHz, 44.1 kHz, 48 kHz, and 96 kHz sampling frequencies.

## Connecting components with multi channel output jacks

If your DVD or Super Audio CD player is equipped with multi channel output jacks, you can connect it to the MULTI CH IN jacks of this receiver to enjoy multi channel sound. Alternatively, the multi channel input jacks can be used to connect an external multi channel decoder.

### Note

When you make connections to the MULTI CH IN jacks, you will need to adjust the level of the speakers and sub woofer using the controls on the connected component.

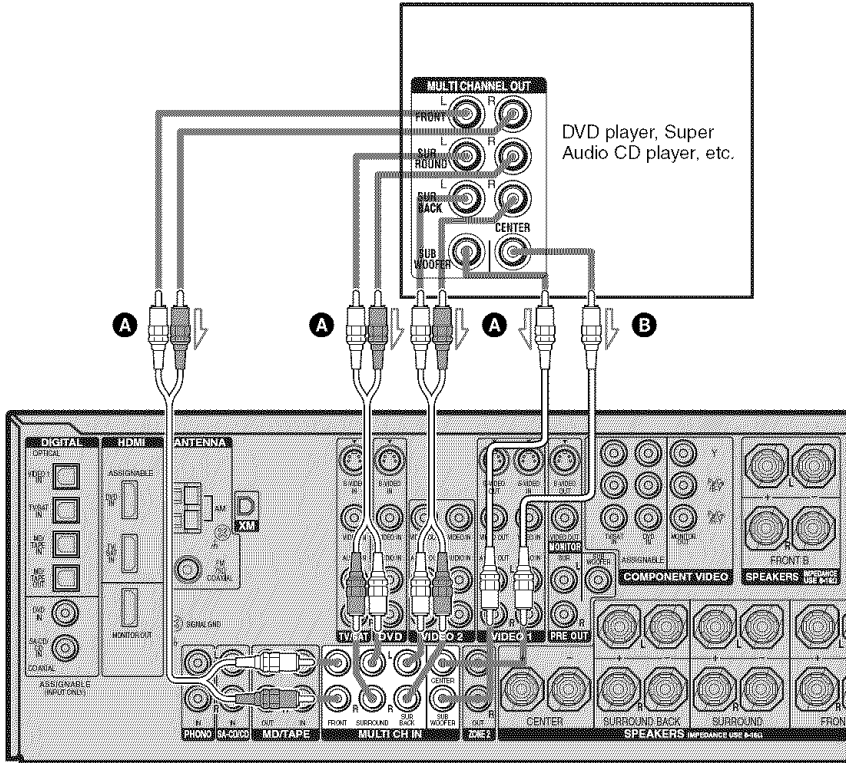

- A** Audio cord (not supplied)
- B** Monaural audio cord (not supplied)

## Connecting components with analog audio jacks

The following illustration shows how to connect a component which has analog jacks such as tape deck, etc.

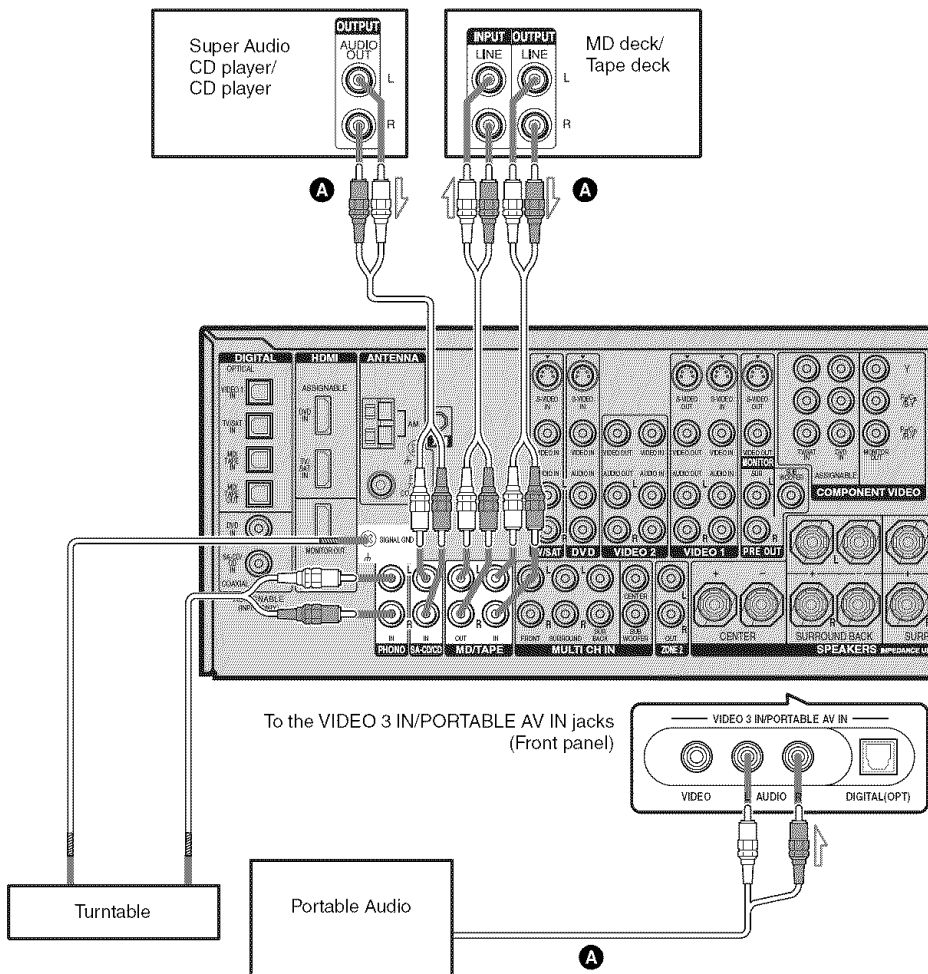

**A** Audio cord (not supplied)

## Notes

- To listen to the portable audio source sound, connect the audio output jack of portable audio to the VIDEO 3 IN/ PORTABLE AV IN (AUDIO) jack of this receiver. For details, refer to operating instructions supplied with the Portable Audio.
- Distortion may occur when listening to a component connected to the VIDEO 3 IN/ PORTABLE AV IN (AUDIO) jack on the front panel of this receiver. This is not a malfunction and will depend on the component connected. To prevent this, you can reduce the input level sound of the other components.

## 3b: Connecting the video components

### How to hook up your components

This section describes how to hook up your components to this receiver. Before you begin, refer to “Component to be connected” below for the pages which describe how to connect each component.

After hooking up all your components, proceed to “4: Connecting the antennas” (page 32).

### Video input/output jack to be connected

The image quality depends on the connecting jack. Refer to the illustration that follows. Select the connection according to the jacks on your components.

### Component to be connected

Component	Page
TV monitor	25
DVD player/DVD recorder	26
Satellite tuner	28
VCR	29
Camcorder, video game, etc.	29
With HDMI jack	30

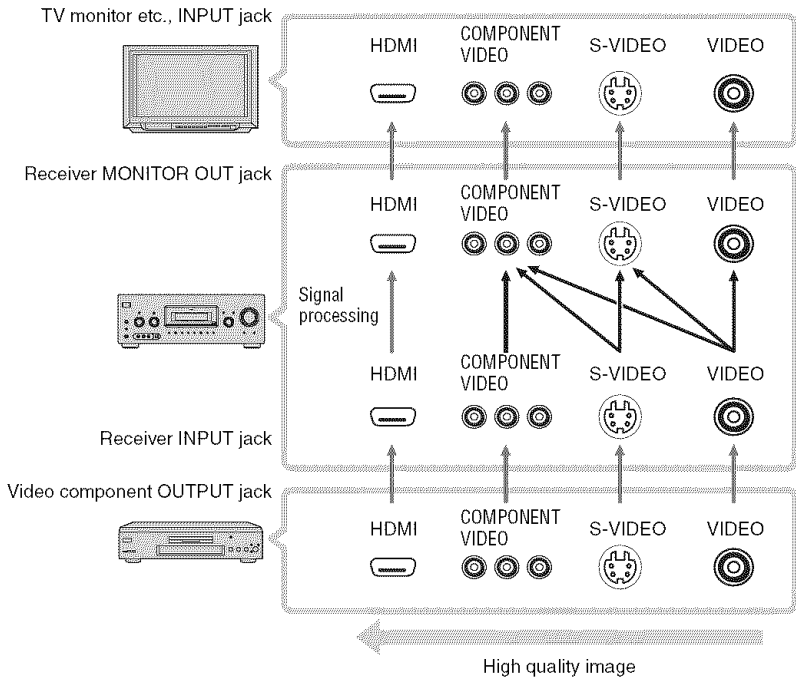

## Notes

- Connect image display components such as a TV monitor or a projector to the MONITOR OUT jack on the receiver.
- Turn on the receiver when the video and audio of a playback component are being output to a TV through the receiver. If the power supply of the receiver is not on, neither video nor audio is transmitted.

## Converting video signals

This receiver is equipped with a function for converting video signals. You can output the video signal after connecting this receiver via the MONITOR OUT jack as shown in the illustration.

Video signals can be output as component video or S-video signals, S-video signals can be output as component video signals and this upconverted video signals can only be output from the MONITOR OUT jack.

## Note on converting video signals

When video signals from a VCR, etc., are converted on this receiver and then output to your TV, depending on the status of the video signal output, the image on the TV screen may appear distorted horizontally or no image may be output.

## Reassigning video input signals to another input

Component video input signals can be reassigned to another input (page 80).



## Hooking up a TV monitor

The image from a visual component connected to this receiver can be displayed on a TV screen.

It is not necessary to connect all the cables. Connect video cords according to the jacks of your components.

## Notes

- Connect image display components such as a TV monitor or a projector to the MONITOR OUT jack on the receiver.
- Turn on the receiver when the video and audio of a playback component are being output to a TV via the receiver. If the power supply of the receiver is not turned on, neither video nor audio is transmitted.

## Tip

You can watch the selected input image when you connect the MONITOR OUT jack to a TV monitor.

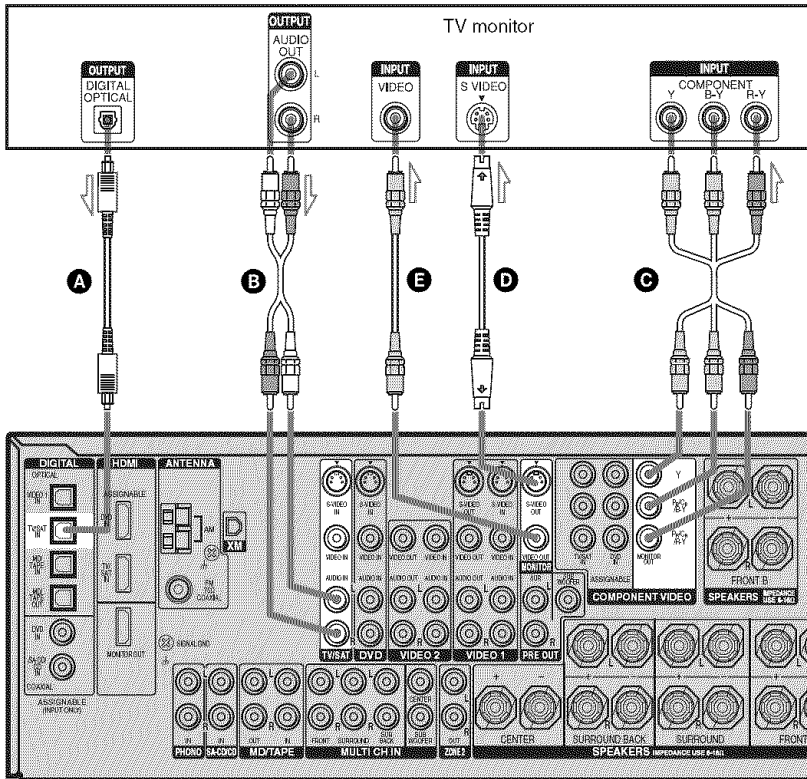

- A** Optical digital cord (not supplied)  
**B** Audio cord (not supplied)

- C** Component video cord (not supplied)  
**D** S-video cord (not supplied)  
**E** Video cord (not supplied)

## Hooking up a DVD player/DVD recorder

The following illustration shows how to connect a DVD player/DVD recorder. It is not necessary to connect all the cables. Connect audio and video cords according to the jacks of your components.

### ① Connecting audio

#### Notes

- To input multi channel digital audio from the DVD player, set the digital audio output setting on the DVD player. Refer to the operating instructions supplied with the DVD player.
- When connecting optical digital cords, insert the plugs straight in until they click into place.
- Do not bend or tie optical digital cords.

#### Tip

All the digital audio jacks are compatible with 32 kHz, 44.1 kHz, 48 kHz, and 96 kHz sampling frequencies.

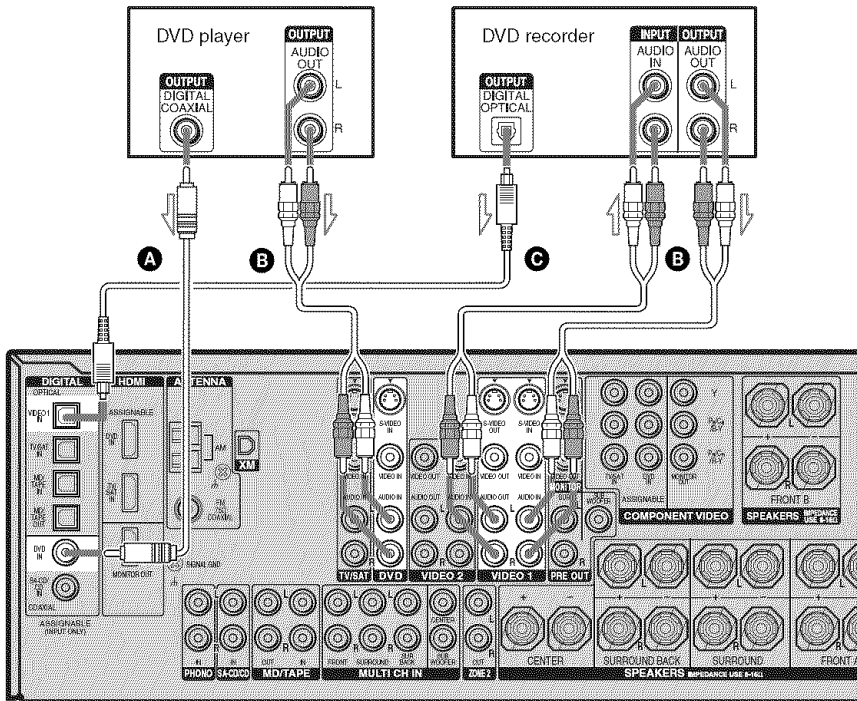

- Ⓐ Coaxial digital cord (not supplied)
- Ⓑ Audio cord (not supplied)
- Ⓒ Optical digital cord (not supplied)

## ② Connecting video

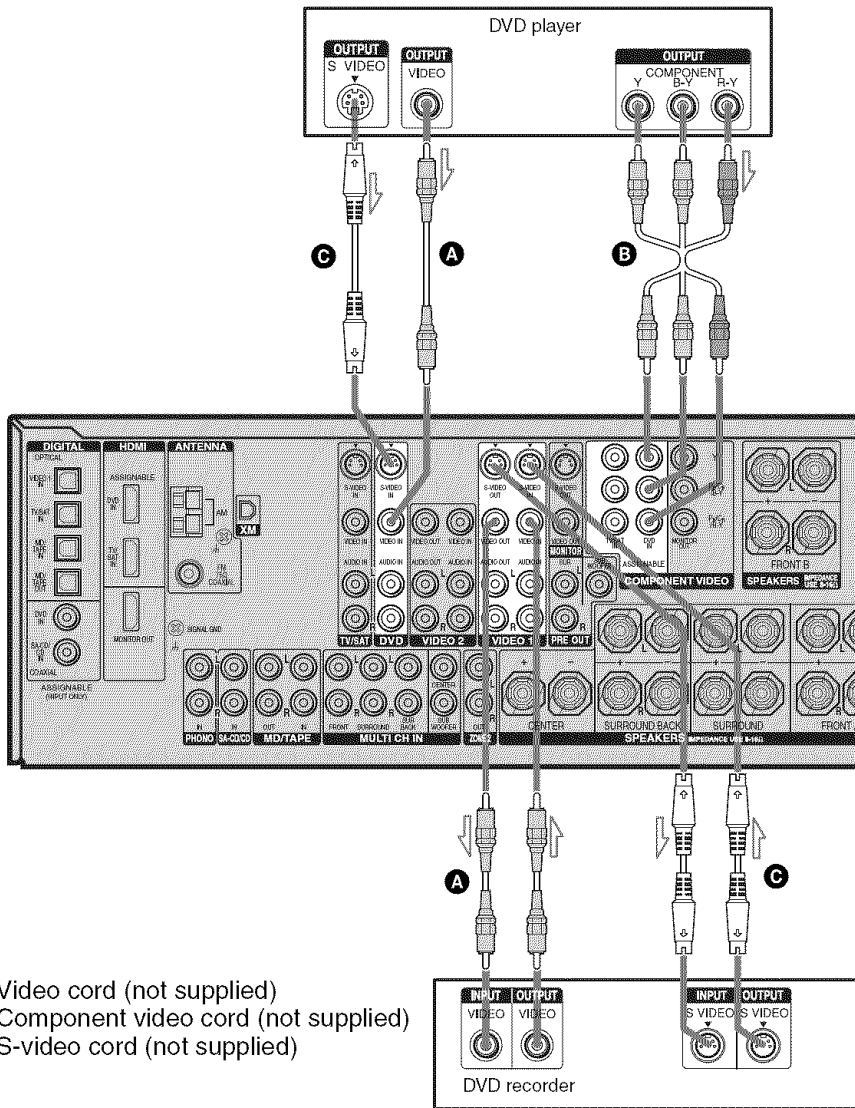

- A** Video cord (not supplied)
- B** Component video cord (not supplied)
- C** S-video cord (not supplied)

### If you connect a DVD recorder

- Be sure to change the factory setting of the VIDEO 1 input button on the remote so that you can use the button to control your DVD recorder. For details, see “Programming the remote” (page 86).

- You can also rename the VIDEO 1 input so that it can be displayed on the receiver’s display. For details, see “Naming inputs” (page 82).

## Hooking up a satellite tuner

The following illustration shows how to connect a satellite tuner.

It is not necessary to connect all the cables. Connect audio and video cords according to the jacks of your components.

### Notes

- When connecting optical digital cords, insert the plugs straight in until they click into place.
- Do not bend or tie optical digital cords.

### Tip

All the digital audio jacks are compatible with 32 kHz, 44.1 kHz, 48 kHz, and 96 kHz sampling frequencies.

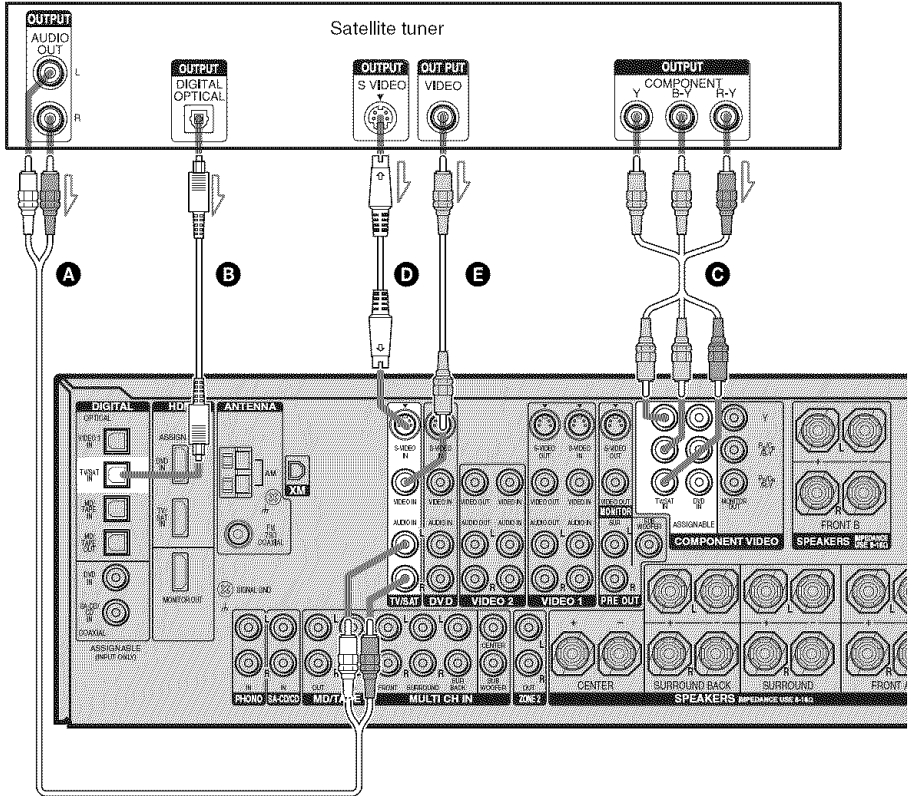

- A** Audio cord (not supplied)
- B** Optical digital cord (not supplied)
- C** Component video cord (not supplied)
- D** S-video cord (not supplied)
- E** Video cord (not supplied)

## Hooking up components with analog video and audio jack

The following illustration shows how to connect a component which has analog jacks such as a VCR, etc.

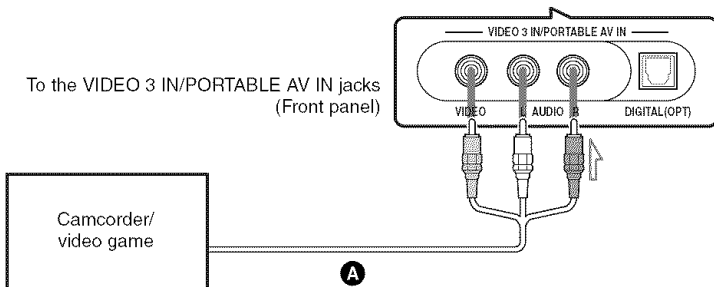
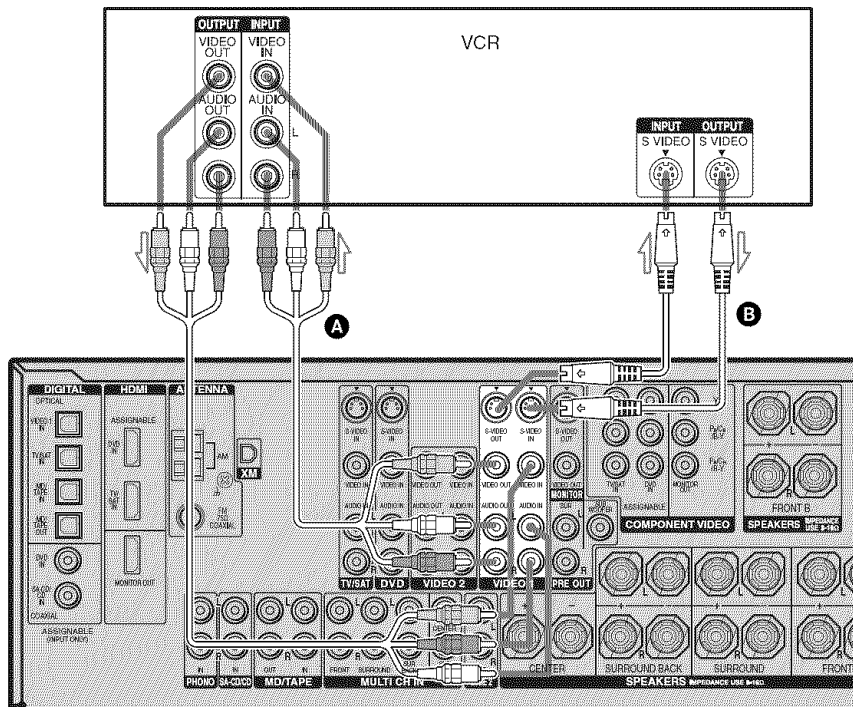

- A** Audio/video cord (not supplied)
- B** S-video cord (not supplied)

## Hooking up components with HDMI jacks

HDMI is the abbreviated name for High-Definition Multimedia Interface. It is an interface which transmits video and audio signals in digital format.

### Note

When a playback component connected to this receiver and this receiver connected to the TV by HDMI, the sound is output from the TV speaker only.

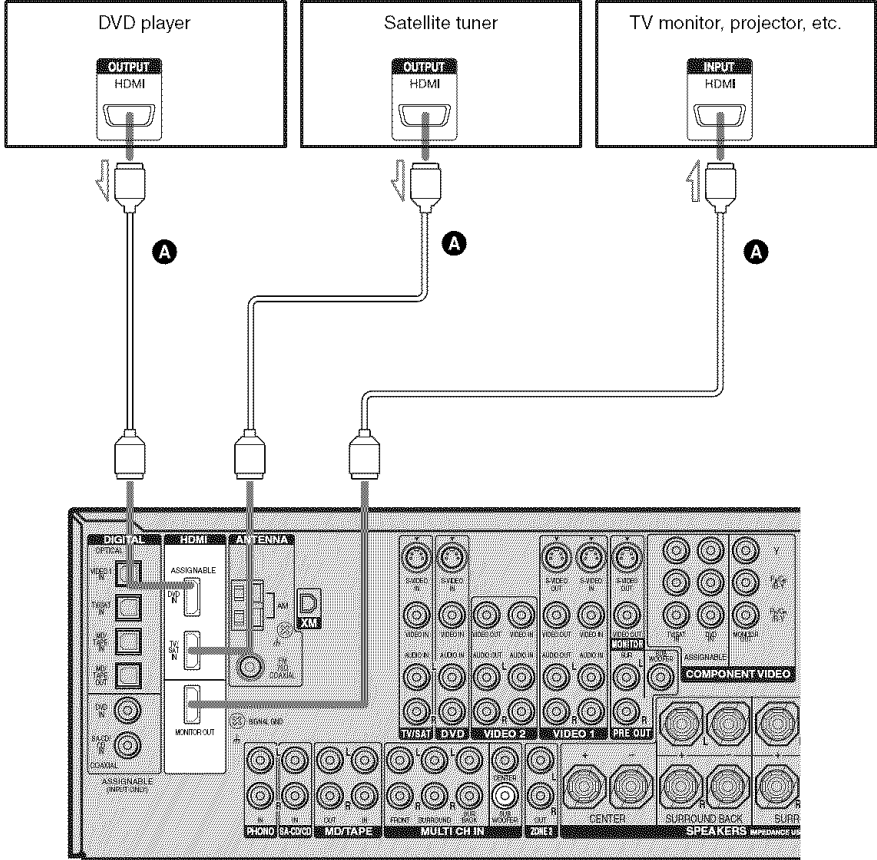

**A** HDMI cable (not supplied)

We recommend that you use a Sony HDMI cable.

## Notes on HDMI connections

- The multi/stereo area audio signals of a Super Audio CD are not output.
- Turn on the receiver when the video and audio of a playback component are being output to a TV via the receiver. If the power supply of the receiver is not turned on, neither video nor audio is transmitted.
- Audio signals (sampling frequency, bit length, etc.) transmitted from a HDMI jack may be restricted by the connected component. Check the setup of the connected component if the image is poor or the sound does not come out of a component connected via the HDMI cable.
- Refer to the operating instructions of each component connected for details.

# 4: Connecting the antennas

Connect the supplied AM loop antenna and FM wire antenna.

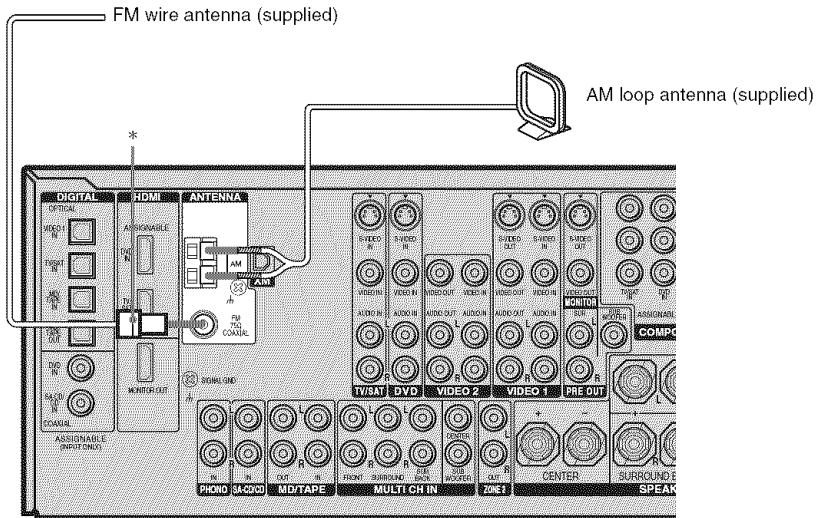

\* The shape of the connector varies depending on the area code of this receiver.

## Notes

- To prevent noise pickup, keep the AM loop antenna away from the receiver and other components.
- Be sure to fully extend the FM wire antenna.
- After connecting the FM wire antenna, keep it as horizontal as possible.
- Do not use the  $\text{h}$  SIGNAL GND terminal for grounding the receiver.



## 5: Preparing the receiver and the remote

### Connecting the AC power cord

Connect the AC power cord to a wall outlet.

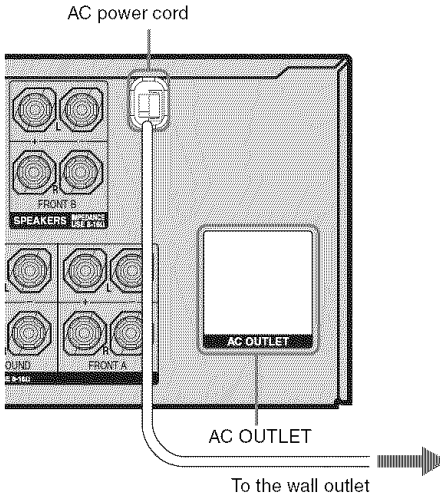

### Notes

- Install this system so that the power cord can be unplugged from the wall socket immediately in the event of trouble.
- The AC OUTLET(s) on the rear of the receiver is a switched outlet, which supplies power to the connected component only while the receiver is turned on.
- Make sure that the total power consumption of the component(s) connected to the receiver's AC OUTLET(s) does not exceed the wattage stated on the rear panel. Do not connect high-wattage electrical home appliances such as electric irons, fans, or TVs to this outlet. This may cause a malfunction.

### Performing initial setup operations

Before using the receiver for the first time, initialize the receiver by performing the following procedure. This procedure can also be used to return settings you have made to their factory defaults.

Be sure to use the buttons on the receiver for this operation.

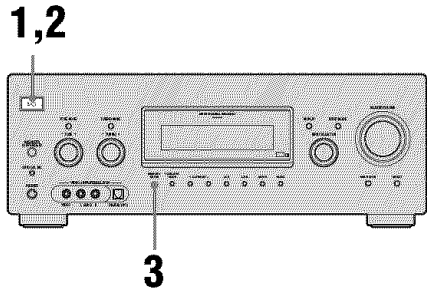

- 1 Press I/O to turn off the receiver.**
- 2 Hold down I/O for 5 seconds.**  
“PUSH ENTER” appears on the display.

### 3 Press MEMORY/ENTER.

After “MEMORY CLEARING” appears on the display for a while, “MEMORY CLEARED” appears.

The following items are reset to their factory settings.

- All settings in the LEVEL, EQ, SUR, TUNER, AUDIO, VIDEO, SYSTEM and AUTO CAL menus.
- The sound field memorized for each input and preset station.
- All sound field parameters.
- All preset stations.
- All index names for inputs and preset stations.
- MASTER VOLUME is set to “VOLUME MIN”.
- Input is set to “DVD”.

## Inserting batteries into the remote

Insert two R6 (size-AA) batteries in the RM-AAP008 remote commander. Observe the correct polarity when installing batteries.

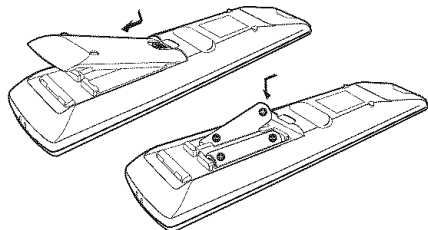

### Notes

- Do not leave the remote in an extremely hot or humid place.
- Do not use a new battery with old ones.
- Do not mix alkaline batteries and other kinds of batteries.
- Do not expose the remote sensor to direct sunlight or lighting apparatuses. Doing so may cause a malfunction.
- If you do not intend to use the remote for an extended period of time, remove the batteries to avoid possible damage from battery leakage and corrosion.

### Tip

Under normal conditions, the batteries should last for about 3 months. When the remote no longer operates the receiver, replace all the batteries with new ones.

## About the command mode

If the command modes of the receiver and the remote are different, you cannot use the remote to operate the receiver. If the command modes of both this receiver and the remote are the initial setting (AV SYSTEM2), it is not necessary to reset them.

## Switching the command mode

You can switch the command mode (AV SYSTEM1 or AV SYSTEM2) of the receiver. The command mode of the remote has been set to AV SYSTEM2. If the command modes of the receiver and the remote are different, you cannot use the remote to operate the receiver.

### To set the command mode of the receiver

Be sure to use the buttons on the receiver for this operation.

Turn on the receiver while pressing INPUT MODE. The command mode is set to AV SYSTEM1 and "C.MODE.AV1" appears on the display. If you repeat the same operation again, the setting will change from AV SYSTEM1 to AV SYSTEM2 and "C.MODE.AV2" appears on the display. The initial setting is "C.MODE.AV2".

### To set the command mode of the remote

You can switch the command mode (AV1 and AV2) of the remote.

#### 1 Press RM SET UP.

The RM SET UP indicator flashes.

#### 2 Press the numeric button 1 (for AV1) or 2 (for AV2).

The RM SET UP indicator lights up.

#### 3 Press ENTER.

The RM SET UP indicator slowly flashes twice and the command mode switches.

### To reset the remote to factory settings

Press **1/⏻**, **AV 1/⏻** and **MASTER VOL -** at the same time.

The RM SET UP indicator flashes 3 times, then goes off.

## 6: Selecting the speaker system

You can select the front speakers you want to drive.

Be sure to use the buttons on the receiver for this operation.

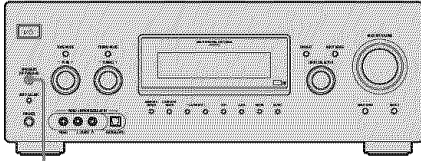

**SPEAKERS**  
(OFF/A/B/A+B)

**Press SPEAKERS (OFF/A/B/A+B) repeatedly to select the front speaker system you want to drive.**

To select	Light up
The speakers connected to the SPEAKERS FRONT A terminals	SP. A
The speakers connected to the SPEAKERS FRONT B terminals	SP. B
The speakers connected to both the SPEAKERS FRONT A and B terminals (parallel connection)	SP. A and SP. B

To turn off the speaker output, press SPEAKERS (OFF/A/B/A+B) repeatedly until the “SP. A” and “SP. B” indicators on the display do not light up.

## 7: Calibrating the appropriate settings automatically (AUTO CALIBRATION)

This receiver is equipped with D.C.A.C. (Digital Cinema Auto Calibration) Technology which allows you to perform automatic calibration as follows:

- Check the connection between each speaker and the receiver.
- Adjust the speaker level.
- Measure the distance of each speaker to your listening position.

You can also adjust the speaker levels and balance manually. For details, see “8: Adjusting the speaker levels and balance (TEST TONE)” (page 39).

### Before you perform Auto Calibration

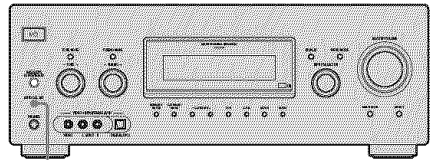

- 1** Connect the supplied ECM-AC2 optimizer microphone to the AUTO CAL MIC jack.
- 2** Place the optimizer microphone at your listening position.
- 3** Place the speakers so that the speakers are facing the optimizer microphone.

## Tips

- You can also fix the optimizer microphone to a tripod (not supplied) and place the tripod at your listening position.
- Be sure to remove any obstacles in the path between the optimizer microphone and the speakers.
- When you face the speaker towards the optimizer microphone, you will get a more accurate measurement.

## Performing Auto Calibration

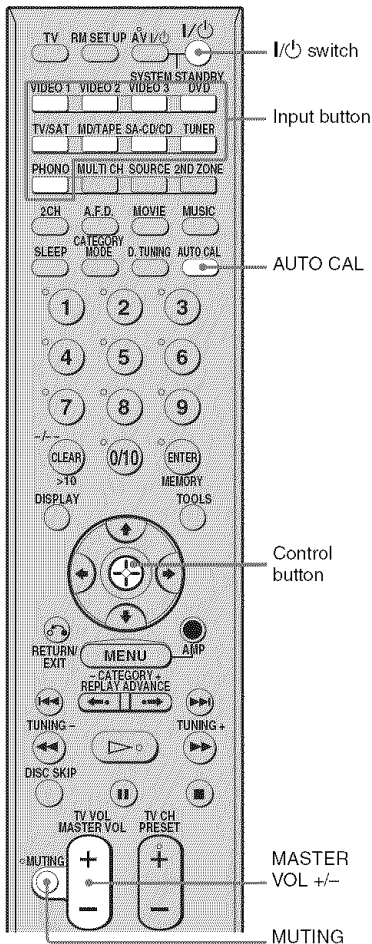

## Press AUTO CAL.

The following appears on the display:  
 AUTO CAL [5] → AUTO CAL [4] →  
 AUTO CAL [3] → AUTO CAL [2] →  
 AUTO CAL [1]

The table below shows the display when measurement starts.

Measurement for	Display
Environment noise level	NOISE CHECK
Speaker connection	MEASURE SP DET.
Speaker level	MEASURE GAIN
Speaker distance	MEASURE DIST.

When measurement ends, “COMPLETE” appears on the display and the settings are registered.

## Notes

- Auto Calibration cannot detect the sub woofer. Therefore, all sub woofer settings will be maintained.
- You cannot select Auto Calibration when headphone is connected.
- The measurement process will take a few minutes to complete.

## Tips

- When Auto Calibration starts:
  - Stand some distance from the speakers and the listening position to avoid measurement failure. This is because test signals are output from the speakers during measurement.
  - Avoid making noise to get a more accurate measurement.
- The Auto Calibration function will be canceled when you do the following during the measurement process:
  - Press I/O, input buttons or MUTING (or turn INPUT SELECTOR on the receiver).
  - Change the volume level.
  - Press AUTO CAL again.

## Error and warning codes

### Error codes

When an error is detected during Auto Calibration, an error code will appear on the display cyclically after each measurement process as follows:

Error code → blank display → (error code → blank display)<sup>a)</sup> → PUSH ENTER

<sup>a)</sup> Appears when there are more than one error code.

### To rectify the error

- 1 Record down the error code.
- 2 Press the control button.
- 3 Press I/⏻ to turn off the receiver.
- 4 Rectify the error.  
For details, see “Error code and remedies” below.
- 5 Turn on the receiver and perform Auto Calibration again (page 36).

### Error code and remedies

Error code	Explanation	Remedies
ERROR CODE 10	The environment is too noisy.	Make sure the environment is quiet during Auto Calibration.
ERROR CODE 11	The speakers are placed too near to the optimizer microphone.	Place your speakers further away from the optimizer microphone.
ERROR CODE 20	Front speakers are not detected or only one front speaker is detected.	Check the front speaker connection.
ERROR CODE 21	Only one surround speaker is detected.	Check the surround speaker connection.

Error code	Explanation	Remedies
ERROR CODE 22	Only one surround back speaker is detected.	Check the surround back speaker connection. If you connect only one surround back speaker, connect it to the SPEAKERS SURROUND BACK L terminal.
ERROR CODE 23	Surround back speaker is detected but surround speakers are not connected.	Be sure to connect the surround speakers.

### Warning codes

During Auto Calibration, the warning code provides information on the measurement result. The warning code will appear on the display cyclically as follows:

Warning code → blank display → (warning code → blank display)<sup>b)</sup> → PUSH ENTER

<sup>b)</sup> Appears when there are more than one warning code.

You can choose to ignore the warning code as the Auto Calibration function will automatically adjust the settings. You can also change the settings manually.

### To change the settings manually

- 1 Record down the warning code.
- 2 Press the control button.
- 3 Press I/⏻ to turn off the receiver.
- 4 Follow the solution provided in the “Warning code and solution” below.
- 5 Turn on the receiver and perform Auto Calibration again (page 36).

## Warning code and solution

Warning code	Explanation	Solution
WARNING CODE 40	The environment is noisy.	Make sure the environment is quiet during Auto Calibration.
WARNING CODE 60	The front speaker balance is out of range.	Reposition your front speakers. <sup>c)</sup>
WARNING CODE 62	The center speaker level is out of range.	Reposition your center speaker. <sup>d)</sup>
WARNING CODE 63	The surround left speaker level is out of range.	Reposition your surround left speaker. <sup>e)</sup>
WARNING CODE 64	The surround right speaker level is out of range.	Reposition your surround right speaker. <sup>f)</sup>
WARNING CODE 65	The surround back speaker level is out of range.	Reposition your surround back speaker. <sup>g)</sup>
WARNING CODE 66	The surround back right speaker level is out of range.	Reposition your surround back right speaker. <sup>h)</sup>
WARNING CODE 70	The front speaker distance is out of range.	Reposition your front speakers. <sup>c)</sup>
WARNING CODE 72	The center speaker distance is out of range.	Reposition your center speaker. <sup>d)</sup>
WARNING CODE 73	The surround left speaker distance is out of range.	Reposition your surround left speaker. <sup>e)</sup>
WARNING CODE 74	The surround right speaker distance is out of range.	Reposition your surround right speaker. <sup>f)</sup>
WARNING CODE 75	The surround back speaker distance is out of range.	Reposition your surround back speaker. <sup>g)</sup>
WARNING CODE 76	The surround back right speaker distance is out of range.	Reposition your surround back right speaker. <sup>h)</sup>

<sup>c)</sup> For details, refer “Front speaker distance” (page 56).

<sup>d)</sup> For details, refer “Center speaker distance” (page 57).

<sup>e)</sup> For details, refer “Surround left speaker distance” (page 58).

<sup>f)</sup> For details, refer “Surround right speaker distance” (page 58).

<sup>g)</sup> For details, refer “Surround back speaker distance” (page 58).

<sup>h)</sup> For details, refer “Surround back right speaker distance” (page 59).

## 8: Adjusting the speaker levels and balance (TEST TONE)

You can adjust the speaker levels and balance while listening to the test tone from your listening position.

### Tip

The receiver employs a test tone with a frequency centered at 800 Hz.

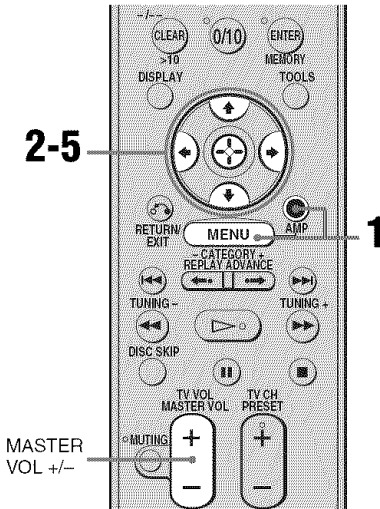

- 1** Press AMP, then press MENU. “1-LEVEL SET” appears on the display.
- 2** Press the control button or control button  $\rightarrow$  to enter the menu.
- 3** Press control button  $\uparrow/\downarrow$  repeatedly to select “TEST TONE”.
- 4** Press the control button or control button  $\rightarrow$  to enter the parameter.

- 5** Press control button  $\uparrow/\downarrow$  repeatedly to select “TEST TONE YES”.

The test tone is output from each speaker in sequence as follows:

Front left  $\rightarrow$  Center  $\rightarrow$  Front right  $\rightarrow$  Surround right  $\rightarrow$  Surround back right\*  $\rightarrow$  Surround back left\*  $\rightarrow$  Surround left  $\rightarrow$  Sub woofer

\*You will only hear the test tone from the  
 – surround back left and right speakers when surround back speaker selection is set to “DUAL”.  
 – surround back left speaker when surround back speaker selection is set to “SINGLE”.

- 6** Adjust the speaker levels and balance using the LEVEL menu so that the level of the test tone sounds the same from each speaker.

For details, see “Adjusting the level (LEVEL menu)” (page 51).

### Tips

- To adjust the level of all speakers at the same time, press MASTER VOL +/- . You can also use MASTER VOLUME on the receiver.
- The adjusted value are shown on the display during adjustment.

- 7** Repeat steps 1 to 5 to select “TEST TONE NO”.

The test tone turns off.

## Selecting a component

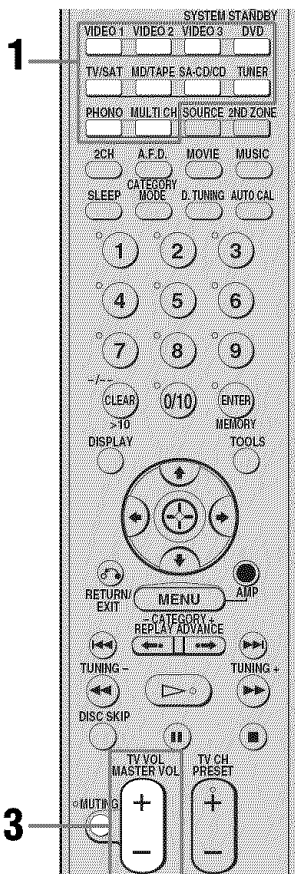

### 1 Press the input button to select a component.

You can also use INPUT SELECTOR on the receiver. To select a component connected to the MULTI CH IN jack, press MULTI CH. You can also use MULTI CH IN on the receiver. The selected input appears on the display.

Selected input [Display]	Components that can be played back
VIDEO 1 or VIDEO 2 [VIDEO 1 or VIDEO 2]	VCR, etc., connected to the VIDEO 1 or VIDEO 2 jack
VIDEO 3 [VIDEO 3]	Camcorder, video game, etc., connected to the VIDEO 3 IN/ PORTABLE AV IN jack
DVD [DVD]	DVD player, etc., connected to DVD jack
MD/TAPE [MD/TAPE]	MD deck, tape deck, etc., connected to the MD/ TAPE jack
SA-CD/CD [SA-CD/CD]	Super Audio CD/CD player, etc., connected to the SA-CD/CD jack
TUNER [FM or AM band]	Built-in radio tuner.
TUNER [XM RADIO]	For details, see page 72.
MULTI CH IN [MULTI DIRECT*]	Component connected to the MULTI CH IN jack
TV/SAT [TV/SAT]	Satellite tuner, etc., connected to the TV/SAT jack
PHONO [PHONO]	Turntable, etc., connected to the PHONO jack

\*When headphone is connected, "HP MULTI" appears on the display.

### Note

The surround effect does not work when MULTI CH IN is selected.

### 2 Turn on the component and start playback.

### 3 Press MASTER VOL +/- to adjust the volume.

You can also use MASTER VOLUME on the receiver.



## To mute the sound

Press **MUTING**.

The muting function will be canceled when you do the following.

- Press **MUTING** again.
- Increase the volume.
- Turn off the receiver.

## To avoid damaging your speakers

Before you turn off the receiver, be sure to turn down the volume level.

# Listening/Watching a component

## Listening to a Super Audio CD/CD

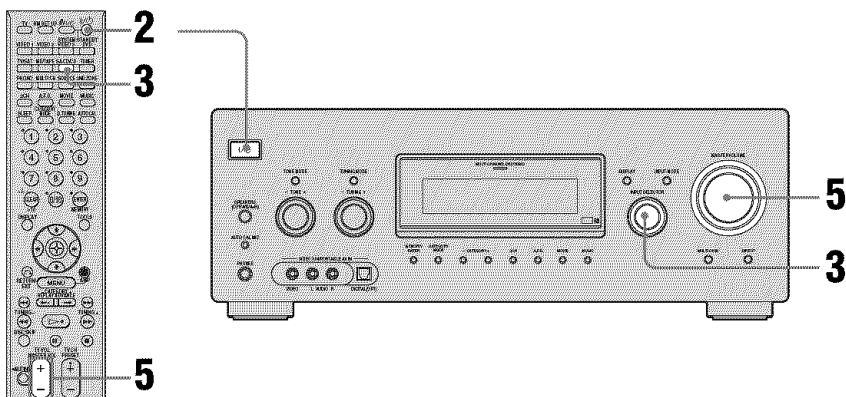

### Notes

- The operation is described for a Sony Super Audio CD player.
- Refer to the operating instructions supplied with the Super Audio CD player or CD player.

### Tips

- You can select the sound field to suit the music. Refer to page 63 for details.  
Recommended sound fields:  
Classical: HALL  
Jazz: JAZZ CLUB  
Live concert: LIVE CONCERT
- You can listen to the sound that was recorded in the 2 channel format from all speakers (multi channel). Refer to page 61 for details.

**1** Turn on the Super Audio CD player/CD player, then place the disc on the tray.

**2** Turn on the receiver.

**3** Press SA-CD/CD.

You can also use INPUT SELECTOR on the receiver to select SA-CD/CD.

**4** Playback the disc.

**5** Adjust to a suitable volume.

**6** After you have finished listening to the Super Audio CD/CD, eject the disc and turn off the receiver and Super Audio CD player/CD player.

## Watching a DVD

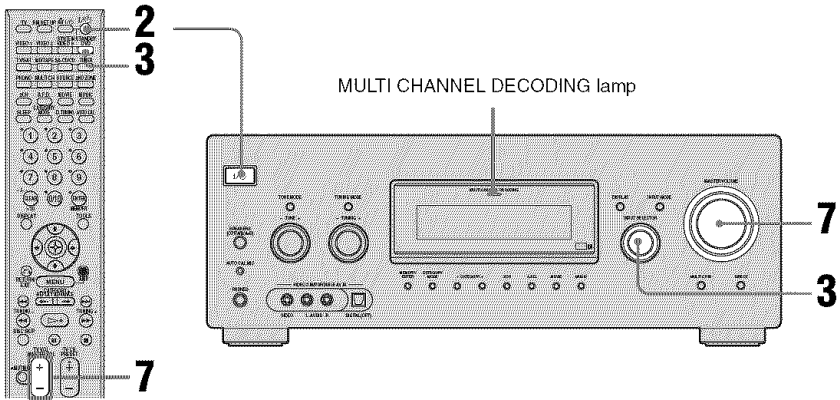

### Notes

- Refer to the operating instructions supplied with the TV and DVD player.
- Check the following if you cannot listen to multi channel sound.
  - Be sure the sound source corresponds to the multi channel format (the MULTI CHANNEL DECODING lamp on the front panel lights up during playback).
  - Be sure this receiver is connected to the DVD player via a digital connection.
  - Be sure the digital audio output of the DVD player is set up properly.

### Tips

- Select the sound format of the disc to be played, if necessary.
- You can select the sound field to suit the movie/music. Refer to page 63 for details.  
Recommended sound fields:  
Movie: CINEMA ST. EX  
Music: LIVE CONCERT

**1** Turn on the TV and DVD player.

**2** Turn on the receiver.

**3** Press DVD.

You can also use INPUT SELECTOR on this receiver to select DVD.

**4** Switch the input of the TV so that an image of the DVD is displayed.

**5** Set up the DVD player.

Refer to "Quick Setup Guide" supplied with the receiver.

**6** Playback the disc.

**7** Adjust to a suitable volume.

**8** After you have finished watching the DVD, eject the disc and turn off the receiver, TV and DVD player.

## Enjoying the video games

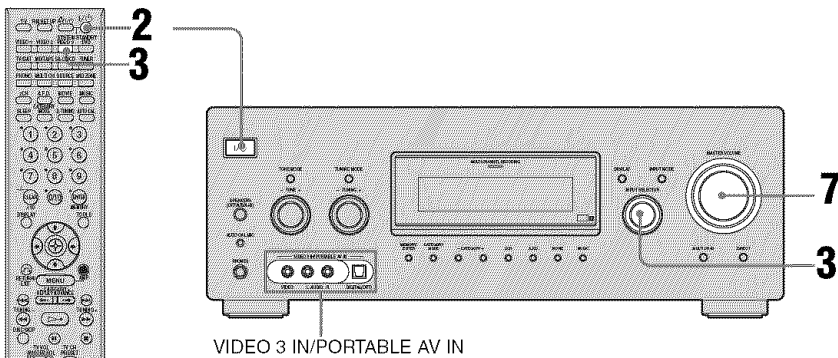

### Note

Refer to the operating instructions supplied with the TV and video game.

### Tip

You can select the sound field to suit the music. Refer to page 62 for details.

Recommended sound fields:  
PLII GAME, PLIIX GAME

- 1 Turn on the TV and video game.
- 2 Turn on the receiver.
- 3 Press VIDEO 3\*.  
You can also use INPUT SELECTOR on this receiver to select VIDEO 3\*.  
\* When you connect a video game to the VIDEO 3 IN/PORTABLE AV IN jack on the front panel.
- 4 Switch the input of the TV so that an image of the video game is displayed.
- 5 Set up the video game.
- 6 Set the disc in the tray and played it back on the video game.
- 7 Adjust to a suitable volume.
- 8 After you have finished enjoying the video games, eject the disc and turn off the receiver, TV and the video game.

## Watching video

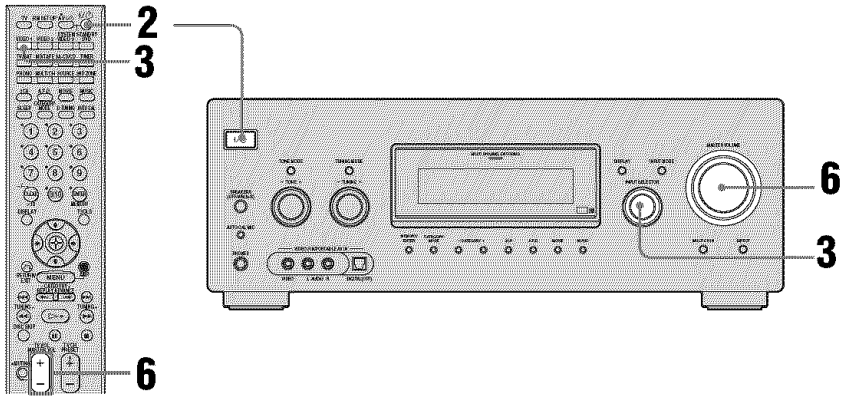

### Note

Refer to the operating instructions supplied with the TV and VCR.

### Tip

You can listen to sound recorded in the 2 channel format from all speakers (multi channel). Refer to page 62 for details.

- 1 Turn on the TV and VCR.**
- 2 Turn on the receiver.**
- 3 Press VIDEO 1\*.**

You can also use INPUT SELECTOR on this receiver to select VIDEO 1\*.  
\* When you connect VCR to the VIDEO 1 jack.
- 4 Switch the input of the TV so that an image of the VCR is displayed.**
- 5 Play back the tape on the VCR.**
- 6 Adjust to a suitable volume.**
- 7 After you have finished watching video, eject the tape and turn off the receiver, TV and VCR.**

## Amplifier Operations

### Navigating through menus

By using the amplifier menus, you can make various adjustments to customize the receiver.

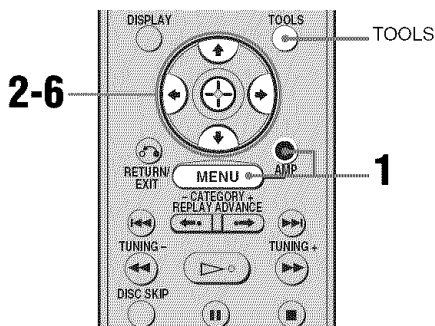

- 1** Press AMP and then press MENU.

“1-LEVEL SET” appears on the display.

- 2** Press control button  $\uparrow/\downarrow$  repeatedly to select the menu you want.
- 3** Press the control button or control button  $\rightarrow$  to enter the menu.
- 4** Press control button  $\uparrow/\downarrow$  repeatedly to select the parameter you want to adjust.
- 5** Press the control button or control button  $\rightarrow$  to enter the parameter.

- 6** Press control button  $\uparrow/\downarrow$  repeatedly to select the setting you want.

The setting is entered automatically.

### To return to the previous display

Press control button  $\leftarrow$ .

### To exit the menu

Press MENU.

However, if the AMP button is light off, press AMP and then press MENU.

### Note

Some parameters and settings may appear dimmed on the display. This means that they are either unavailable or fixed and unchangeable.

## Overview of the menus

The following options are available in each menu. For details on navigating through menus, see page 46.

Menu [Display]	Parameters [Display]	Settings	Initial setting
LEVEL (51) [1-LEVEL SET]	Test tone <sup>a)</sup> [TEST TONE]	TEST TONE NO, TEST TONE YES	TEST TONE NO
	Front speaker balance <sup>a)</sup> [FRONT BALANCE]	BALANCE L +1 to BALANCE L +8, BALANCE BALANCE, BALANCE R +1 to BALANCE R +8	BALANCE
	Center speaker level [CENTER LEVEL]	CENTER -10 dB to CENTER +10 dB (1 dB step)	CENTER 0 dB
	Surround left speaker level [SUR L LEVEL]	SUR L -10 dB to SUR L +10 dB (1 dB step)	SUR L 0 dB
	Surround right speaker level [SUR R LEVEL]	SUR R -10 dB to SUR R +10 dB (1 dB step)	SUR R 0 dB
	Surround back speaker level [SB LEVEL] <sup>b)</sup>	SB -10 dB to SB +10 dB (1 dB step)	SB 0 dB
	Surround back left speaker level [SB L LEVEL] <sup>c)</sup>	SB LEFT -10 dB to SB LEFT +10 dB (1 dB step)	SB LEFT 0 dB
	Surround back right speaker level [SB R LEVEL] <sup>c)</sup>	SB RIGHT -10 dB to SB RIGHT +10 dB (1 dB step)	SB RIGHT 0 dB
	Sub woofer level [SW LEVEL]	SW -10 dB to SW +10 dB (1 dB step)	SW 0 dB
EQ (52) [2-EQ SET]	Dynamic range compressor <sup>a)</sup> [COMP. LEVEL]	COMP. OFF, COMP. STD, COMP. MAX	COMP. OFF
	Equalizer on/off [EQ ON/OFF]	EQUALIZER ON, EQUALIZER OFF	EQUALIZER OFF
	Front speaker bass level [BASS GAIN]	BASS -10 dB to BASS +10 dB (0.5 dB step)	BASS 0 dB
	Front speaker treble level [TREBLE GAIN]	TREBLE -10 dB to TREBLE +10 dB (0.5 dB step)	TREBLE 0 dB

<b>Menu [Display]</b>	<b>Parameters [Display]</b>	<b>Settings</b>	<b>Initial setting</b>
SURROUND (52) [3-SUR SET]	Sound field selection <sup>a)</sup> [S.FIELD SELECT]	2CH STEREO, A.F.D. AUTO, PRO LOGIC, PL II MOVIE, PL II MUSIC, PL II GAME, PL IIX MOVIE, PL IIX MUSIC, PL IIX GAME, NEO6 CINEMA, NEO6 MUSIC, MULTI STEREO, CINEMA ST. EX A, CINEMA ST. EX B, CINEMA ST. EX C, PORTABLE AUDIO, HALL, JAZZ CLUB, LIVE CONCERT	2CH STEREO for: TUNER, SA-CD/CD, PHONO, MD/ TAPE; A.F.D. AUTO for: DVD, VIDEO 1, 2, 3, TV/SAT
	Surround back decoding mode <sup>a)</sup> [SB DECODING]	SB DEC OFF, SB DEC AUTO, SB DEC ON	SB DEC AUTO
	Effect level <sup>a)</sup> [EFFECT LEVEL]	EFFECT MIN, EFFECT STD, EFFECT MAX	EFFECT STD
TUNER (54) [4-TUNER SET]	FM station receiving mode <sup>a)</sup> [FM MODE]	FM MODE AUTO, FM MODE MONO	FM MODE AUTO
	Naming preset stations <sup>a)</sup> [NAME IN]		
AUDIO (55) [5-AUDIO SET]	Digital audio input decoding priority <sup>a)</sup> [DECODE PRIORITY]	DEC. PRI. PCM, DEC. PRI. AUTO	DEC. PRI. AUTO for: VIDEO 1, 3, TV/SAT; DEC. PRI. PCM for: DVD, MD/TAPE, SA-CD/CD
	Digital broadcast language selection <sup>a)</sup> [DUAL MONO]	DUAL MONO M/S, DUAL MONO MAIN, DUAL MONO SUB, DUAL MONO M+S	DUAL MONO MAIN
	A/V Sync <sup>a)</sup> [A/V SYNCHRONIZE]	A/V SYNC 0 to A/V SYNC 20	A/V SYNC 0
	Digital Assign [DIGITAL ASSIGN]	VIDEO 1–VIDEO 1, VIDEO 1– VIDEO 2, VIDEO 1–DVD, VIDEO 1–SA-CD, VIDEO 3–VIDEO 2, VIDEO 3–VIDEO 3, VIDEO 3– DVD, VIDEO 3–SA-CD, DVD– VIDEO 1, DVD–VIDEO 2, DVD– VIDEO 3, DVD–DVD, DVD–TV/ SAT, DVD–MD/TAPE, TV/SAT– VIDEO 2, TV/SAT–DVD, TV/SAT– TV/SAT, TV/SAT–SA-CD, MD/ TAPE–VIDEO 2, MD TAPE–DVD, MD/TAPE–MD/TAPE, MD/TAPE– SA-CD, SA-CD–VIDEO 1, SA-CD – VIDEO 2, SA-CD–VIDEO 3, SA- CD–TV/SAT, SA-CD– SA-CD, SA- CD–MD/TAPE	VIDEO 1– VIDEO 1 for: VIDEO 1 OPT; VIDEO 3 – VIDEO 3 for: VIDEO 3 OPT; DVD – DVD for: DVD COAX; TV/SAT – TV/ SAT for: TV/SAT OPT; MD/TAPE – MD/TAPE for: MD/TAPE OPT; SA-CD – SA-CD for: SA-CD/CD COAX
Naming inputs <sup>a)</sup> [NAME IN]			



Menu [Display]	Parameters [Display]	Settings	Initial setting
VIDEO (56) [6-VIDEO SET]	Component video assign <sup>a)</sup> [COMPO V. ASSIGN]	DVD-VIDEO 1, DVD-VIDEO 2, DVD-VIDEO 3, DVD-DVD, DVD-MD/TAPE, DVD-SA-CD, TV/SAT-VIDEO 1, TV/SAT- VIDEO 2, TV/SAT-VIDEO 3, TV/SAT-TV/SAT, TV/SAT-MD/ TAPE, TV/SAT-SA-CD	DVD-DVD for: DVD; TV/SAT-TV/ SAT for: TV/SAT
	HDMI video assign [HDMI V. ASSIGN]	DVD-VIDEO 1, DVD-VIDEO 2, DVD-VIDEO 3, DVD-DVD, DVD-MD/TAPE, DVD-SA-CD, TV/SAT-VIDEO 1, TV/SAT- VIDEO 2, TV/SAT-VIDEO 3, TV/SAT-TV/SAT, TV/SAT-MD/ TAPE, TV/SAT-SA-CD	DVD-DVD for: DVD; TV/ SAT-TV/SAT for: TV/SAT
	Naming inputs <sup>a)</sup> [NAME IN]		
SYSTEM (56) [7-SYSTEM SET]	Sub woofer <sup>a)</sup> [SUB WOOFER]	SUB WOOFER YES, SUB WOOFER NO	SUB WOOFER YES
	Front speakers <sup>a)</sup> [FRONT SPEAKER]	FRONT SP LARGE, FRONT SP SMALL	FRONT SP LARGE
	Center speakers <sup>a)</sup> [CENTER SPEAKER]	CTR SP LARGE, CTR SP SMALL, CTR SP NO	CTR SP LARGE
	Surround speakers <sup>a)</sup> [SUR SPEAKER]	SUR SP LARGE, SUR SP SMALL, SUR SP NO	SUR SP LARGE
	Surround back speaker <sup>a)</sup> [SB SPEAKER]	SB SP NO, SB SP SINGLE, SB SP DUAL	SB SP DUAL
	Front speaker distance <sup>a)</sup> [FRONT DIST.]	FRONT DIST. 3 ft. to FRONT DIST. 23 ft. (1 ft. step)	FRONT DIST. 10 ft.
	Center speaker distance <sup>a)</sup> [CENTER DIST.]	CENTER DIST. ■■ ft. between front speaker distance and 5 ft. (1 ft. step)	CENTER DIST. 10 ft.
	Surround left speaker distance <sup>a)</sup> [SUR L DIST.]	SUR L DIST. ■■ ft. between front speaker distance and 15 ft. (1 ft. step)	SUR L DIST. 10 ft.
Surround right speaker distance <sup>a)</sup> [SUR R DIST.]	SUR R DIST. ■■ ft. between front speaker distance and 15 ft. (1 ft. step)	SUR R DIST. 10 ft.	
Surround back speaker distance <sup>a)b)</sup> [S.BACK DIST.]	S.BACK DIST. ■■ ft. between front speaker distance and 15 ft. (1 ft. step)	S.BACK DIST. 10 ft.	

<b>Menu [Display]</b>	<b>Parameters [Display]</b>	<b>Settings</b>	<b>Initial setting</b>
SYSTEM (56) [7-SYSTEM SET]	Surround back left speaker distance <sup>a)</sup> <sup>c)</sup> [SB L DIST.]	SB L DIST. ■■ ft. between front speaker distance and 15 ft. (1 ft. step)	SB L DIST. 10 ft.
	Surround back right speaker distance <sup>a)</sup> <sup>c)</sup> [SB R DIST.]	SB R DIST. ■■ ft. between front speaker distance and 15 ft. (1 ft. step)	SB R DIST. 10 ft.
	Surround speaker position <sup>a)</sup> [SUR PLACEMENT]	PL. SIDE/LOW, PL. SIDE/HIGH, PL. BEHD/LOW, PL. BEHD/HIGH	PL. SIDE/ LOW
	Speaker crossover frequency <sup>a)</sup> [CROSSOVER FREQ]	CROSS > 40 Hz to CROSS > 160 Hz	CROSS > 100 Hz
	Brightness of the display <sup>a)</sup> [DIMMER]	0% dim, 40% dim, 70% dim	0% dim
	Zone 2 [ZONE 2 SELECT]	ZONE 2 SOURCE, ZONE 2 TUNER, ZONE 2 SA-CD/CD, ZONE 2 MD/ TAPE	ZONE 2 SOURCE
AUTO CALIBRATION (60) [8-AUTO CAL SET]	Auto Calibration <sup>a)</sup> [A. CALIBRATION]	AUTO CAL YES, AUTO CAL NO	AUTO CAL NO

<sup>a)</sup>For details, refer to the page in the parentheses.

<sup>b)</sup>When the surround back speakers are set to "SINGLE".

<sup>c)</sup>When the surround back speakers are set to "DUAL".

# Adjusting the level

## (LEVEL menu)

You can use the LEVEL menu to adjust the balance and level of each speaker. These settings are applied to all sound fields. Select “1-LEVEL SET” in the amplifier menus. For details on adjusting the parameters, see “Navigating through menus” (page 46) and “Overview of the menus” (page 47).

### LEVEL menu parameters

#### ■ TEST TONE (Test tone)

Lets you adjust the speaker levels and balance while listening to the test tone from your listening position. For details, see “8: Adjusting the speaker levels and balance (TEST TONE)” (page 39).

#### ■ FRONT BALANCE (Front speaker balance)

Lets you adjust the balance between front left and right speakers.

#### ■ CENTER LEVEL (Center speaker level)

#### ■ SUR L LEVEL (Surround left speaker level)

#### ■ SUR R LEVEL (Surround right speaker level)

#### ■ SB LEVEL (Surround back speaker level)<sup>a)</sup>

#### ■ SB L LEVEL (Surround back left speaker level)<sup>b)</sup>

#### ■ SB R LEVEL (Surround back right speaker level)<sup>b)</sup>

#### ■ SW LEVEL (Sub woofer level)

<sup>a)</sup>When the surround back speakers are set to “SINGLE”.

<sup>b)</sup>When the surround back speakers are set to “DUAL”.

#### ■ COMP. LEVEL (Dynamic range compressor)

Lets you compress the dynamic range of the sound track. This may be useful when you want to watch movies at low volumes late at night. Dynamic range compression is possible with Dolby Digital sources only.

- COMP. OFF  
The dynamic range is not compressed.
- COMP. STD  
The dynamic range is compressed as intended by the recording engineer.
- COMP. MAX  
The dynamic range is compressed dramatically.

#### Tip

Dynamic range compressor lets you compress the dynamic range of the soundtrack based on the dynamic range information included in the Dolby Digital signal.

“COMP. STD” is the standard setting, but it only enacts light compression. Therefore, we recommend using the “COMP. MAX” setting. This greatly compresses the dynamic range and lets you view movies late at night at low volumes. Unlike analog limiters, the levels are predetermined and provide a very natural compression.

## Adjusting the equalizer (EQ menu)

You can use the EQ menu to adjust the tonal quality (bass/treble level) of the front speakers. These settings are applied to all sound fields. Select “2-EQ SET” in the amplifier menus. For details on adjusting the parameters, see “Navigating through menus” (page 46) and “Overview of the menus” (page 47).

### EQ menu parameters

#### ■ EQ (Equalizer)

Lets you turn the equalizer on or off.

- EQ ON  
The equalizer is turn on.
- EQ OFF  
The equalizer is turn off.

#### ■ BASS GAIN (Front speaker bass level)

#### ■ TREBLE GAIN (Front speaker treble level)

## Settings for the surround sound (SUR menu)

You can use the SUR menu to select the sound field you want for your listening pleasure. Select “3-SUR SET” in the amplifier menus. For details on adjusting the parameters, see “Navigating through menus” (page 46) and “Overview of the menus” (page 47).

### SUR menu parameters

#### ■ S.FIELD SELECT (Sound field selection)

Lets you select the sound field you want. For details, see “Enjoying Surround Sound” (page 61).

#### Note

The receiver lets you apply the last selected sound field to an input whenever it is selected (Sound Field Link). For example, if you select HALL for the SA-CD/CD input, then change to a different input and then return to SA-CD/CD, HALL will automatically be applied again.

#### ■ SB DECODING (Surround back decoding mode)

Lets you select the surround back decoding mode. For details, see “Using the surround back decoding mode” (page 53).

#### ■ EFFECT LEVEL (Effect level)

Lets you adjust the “presence” of the surround effect for sound fields selected with the MOVIE or MUSIC buttons and for “HP THEATER” sound field.

- EFFECT MIN  
The surround effect is minimum.
- EFFECT STD  
The surround effect is standard.
- EFFECT MAX  
The surround effect is maximum.

## Using the surround back decoding mode

### (SUR BACK DECODING)

By decoding the surround back signal of DVD software (etc.) recorded in Dolby Digital Surround EX, DTS-ES Matrix, DTS-ES Discrete 6.1, etc., format, you can enjoy the surround sound intended by the filmmakers. Select the surround back decoding mode using “SB DECODING” on the SUR menu (page 52).

## Types of the surround back decoding functions

### ■ SB DEC AUTO

When the input stream contains the 6.1 channel decode flag<sup>a)</sup>, the appropriate decoding is performed on the surround back signal.

Input stream	Output channel	Surround back decoding
Dolby Digital 5.1	5.1 <sup>e)</sup>	—
Dolby Digital Surround EX <sup>b)</sup>	6.1 <sup>e)</sup>	Matrix decoder that conforms to Dolby Digital EX
DTS 5.1	5.1 <sup>e)</sup>	—
DTS-ES Matrix 6.1 <sup>c)</sup>	6.1 <sup>e)</sup>	DTS Matrix decoding
DTS-ES Discrete 6.1 <sup>d)</sup>	6.1 <sup>e)</sup>	DTS Discrete decoding
Dolby Digital Surround EX <sup>b)</sup>	7.1	Matrix decoder that conforms to Dolby Pro Logic IIX
DTS-ES Matrix 6.1 <sup>c)</sup>	7.1	DTS Matrix decoding
DTS-ES Discrete 6.1 <sup>d)</sup>	7.1	DTS Discrete decoding

### ■ SB DEC ON

To decode the surround back signal regardless of the 6.1 channel decode flag<sup>a)</sup>, Dolby Digital EX is applied when the output channel is 6.1.

Input stream	Output channel	Surround back decoding
Dolby Digital 5.1	6.1 <sup>e)</sup>	Matrix decoder that conforms to Dolby Digital EX
Dolby Digital Surround EX <sup>b)</sup>	6.1 <sup>e)</sup>	Matrix decoder that conforms to Dolby Digital EX
DTS 5.1	6.1 <sup>e)</sup>	Matrix decoder that conforms to Dolby Digital EX
DTS-ES Matrix 6.1 <sup>c)</sup>	6.1 <sup>e)</sup>	Matrix decoder that conforms to Dolby Digital EX
DTS-ES Discrete 6.1 <sup>d)</sup>	6.1 <sup>e)</sup>	Matrix decoder that conforms to Dolby Digital EX
Dolby Digital 5.1	7.1	Matrix decoder that conforms to Dolby Pro Logic IIX
Dolby Digital Surround EX <sup>b)</sup>	7.1	Matrix decoder that conforms to Dolby Pro Logic IIX
DTS 5.1	7.1	Matrix decoder that conforms to Dolby Digital EX
DTS-ES Matrix 6.1 <sup>c)</sup>	7.1	Matrix decoder that conforms to Dolby Digital EX
DTS-ES Discrete 6.1 <sup>d)</sup>	7.1	Matrix decoder that conforms to Dolby Digital EX

## ■ SB DEC OFF

Surround back decoding is not performed.

- a) A 6.1 channel decode flag is information recorded in software such as DVDs.
- b) A Dolby Digital DVD that includes a Surround EX flag. The Dolby Corporation web page can help you distinguish Surround EX films.
- c) Software encoded with a flag to denote it has both DTS-ES Matrix and 5.1 channel signals.
- d) Software encoded with both 5.1 channel signals and an extension stream designed for returning those signals to 6.1 discrete channels. Discrete 6.1 channel signals are DVD specific signals not used in movie theaters.
- e) When two surround back speakers are connected, the output channel will be 7.1 channel.

## Notes

- There may be no sound from the surround back speaker in Dolby Digital EX mode. Some discs have no Dolby Digital Surround EX flag even though the packages have Dolby Digital EX logos. In this case, select “SB DEC ON”.
- You can select the surround back decoding mode only when A.F.D. mode is selected except for Dolby Pro Logic IIx mode.

# Settings for the tuner

## (TUNER menu)

You can use the TUNER menu to set the FM station receiving mode and to name preset stations.

Select “4-TUNER SET” in the amplifier menus. For details on adjusting the parameters, see “Navigating through menus” (page 46) and “Overview of the menus” (page 47).

## TUNER menu parameters

### ■ FM MODE (FM station receiving mode)

- FM MODE AUTO  
This receiver will decode the signal as stereo signal when the radio station is broadcast in stereo.
- FM MODE MONO  
This receiver will decode the signal as mono signal regardless of the broadcast signal.

### ■ NAME IN (Naming preset stations)

Lets you set the name of preset stations. For details, see “Naming preset stations” (page 71).

# Settings for the audio

## (AUDIO menu)

You can use the AUDIO menu to make settings for the audio to suit your preference.

Select “5-AUDIO SET” in the amplifier menus. For details on adjusting the parameters, see “Navigating through menus” (page 46) and “Overview of the menus” (page 47).

## AUDIO menu parameters

### ■ DECODE PRIORITY (Digital audio input decoding priority)

Lets you specify the input mode for the digital signal input to the DIGITAL IN jacks.

- DEC. PRI. AUTO

Automatically switches the input mode between DTS, Dolby Digital, or PCM.

- DEC. PRI. PCM

PCM signals are given priority (to prevent interruption when playback starts).

However, when other signals are input, there may be no sound depending on the format.

In this case, set to “DEC. PRI. AUTO”.

### Note

When set to “DEC. PRI. AUTO” and the sound from the digital audio jacks (for CD, etc.) is interrupted when playback starts, set to “DEC. PRI. PCM”.

### ■ DUAL MONO (Digital broadcast language selection)

Lets you select the language you want to listen to during digital broadcast. This feature only functions for Dolby Digital sources.

- DUAL MONO MAIN (Main)  
Sound of the main language will be output.
- DUAL MONO SUB (Sub)  
Sound of the sub language will be output.
- DUAL MONO M+S (Main + Sub)  
Mixed sound of both the main and sub languages will be output.
- DUAL MONO M/S (Main/Sub)  
Sound of the main language will be output through the front left speaker and sound of the sub language will be output through the front right speaker simultaneously.

### ■ A/V SYNCHRONIZE (Time alignment)

Lets you delay the audio output so that the time gap between the audio output and visual display is minimized. You can adjust from 0 (0 ms) to 20 (200 ms) in 1 (10 ms) steps.

### ■ DIGITAL ASSIGN (Digital audio input assignment)

Lets you assign the digital audio input to other input source. For details, see “Listening to digital sound from other inputs (DIGITAL ASSIGN)” (page 78).

### ■ NAME IN (Naming inputs)

Lets you set the name of inputs. For details, see “Naming inputs” (page 82).

## Settings for the video (VIDEO menu)

You can use the VIDEO menu to reassign the component video input to another input and to name inputs.

Select “6-VIDEO SET” in the amplifier menus. For details on adjusting the parameters, see “Navigating through menus” (page 46) and “Overview of the menus” (page 47).

### VIDEO menu parameters

#### ■ COMPO V. ASSIGN (Component video assign)

Lets you reassign the component video input to another input. For details, see “Watching component images from other inputs” on page 80.

#### ■ HDMI V. ASSIGN (HDMI video assign)

Lets you reassign the HDMI video input to another visual input. For details, see “Watching HDMI image from other inputs (HDMI VIDEO ASSIGN)” on page 81.

#### ■ NAME IN (Naming inputs)

Lets you set the name of inputs. For details, see “Naming inputs” (page 82).

## Settings for the system (SYSTEM menu)

You can use the SYSTEM menu to set the size and distance of the speakers connected to this system.

Select “7-SYSTEM SET.” in the amplifier menus. For details on adjusting the parameters, see “Navigating through menus” (page 46) and “Overview of the menus” (page 47).

### SYSTEM menu parameters

#### ■ SUB WOOFER (Sub woofer)

- SUB WOOFER YES  
If you have connected a sub woofer, select “SUB WOOFER YES”.
- SUB WOOFER NO  
If you have not connected a sub woofer, select “SUB WOOFER NO”. This activates the bass redirection circuitry and outputs the LFE signals from other speakers.

#### Tip

In order to take full advantage of the Dolby Digital bass redirection circuitry, we recommend setting the sub woofer’s cut off frequency as high as possible.

#### ■ FRONT SPEAKER (Front speakers)

- FRONT SP LARGE  
If you connect large speakers that will effectively reproduce bass frequencies, select “FRONT SP LARGE”. Normally, select “FRONT SP LARGE”. When the sub woofer is set to “SUB WOOFER NO”, the front speakers are automatically set to “FRONT SP LARGE”.



- **FRONT SP SMALL**

If the sound is distorted, or you feel a lack of surround effects when using multi channel surround sound, select “FRONT SP SMALL” to activate the bass redirection circuitry and output the front channel bass frequencies from the sub woofer. When the front speakers are set to “FRONT SP SMALL”, the center and surround speakers are also automatically set to “CTR SP SMALL” and “SUR SP SMALL” (unless previously set to “CTR SP NO” and “SUR SP NO”).

- **CENTER SPEAKER (Center speaker)**

- **CTR SP LARGE**

If you connect a large speaker that will effectively reproduce bass frequencies, select “CTR SP LARGE”. Normally, select “CTR SP LARGE”. However, if the front speakers are set to “FRONT SP SMALL”, you cannot set the center speaker to “CTR SP LARGE”.

- **CTR SP SMALL**

If the sound is distorted, or you feel a lack of surround effects when using multi channel surround sound, select “CTR SP SMALL” to activate the bass redirection circuitry and output the center channel bass frequencies from the front speakers (if set to “FRONT SP LARGE”) or sub woofer.

- **CTR SP NO**

If you have not connected a center speaker, select “CTR SP NO”. The sound of the center channel will be output from the front speakers.

- **SUR SPEAKER (Surround speakers)**

The surround back speaker will be set to the same setting.

- **SUR SP LARGE**

If you connect large speakers that will effectively reproduce bass frequencies, select “SUR SP LARGE”. Normally, select “SUR SP LARGE”. However, if the front speakers are set to “FRONT SP SMALL”, you cannot set the surround speakers to “SUR SP LARGE”.

- **SUR SP SMALL**

If the sound is distorted, or you feel a lack of surround effects when using multi channel surround sound, select “SUR SP SMALL” to activate the bass redirection circuitry and output the surround channel bass frequencies from the sub woofer or other speaker that is set to “LARGE”.

- **SUR SP NO**

If you have not connected surround speakers, select “SUR SP NO”.

- **SB SPEAKER (Surround back speaker)**

When the surround speakers are set to “SUR SP NO”, the surround back speaker is also automatically set to “SB SP NO” and the setting cannot be changed.

- **SB SP DUAL**

If you connect two surround back speakers, select “SB SP DUAL”. The sound will be output to a maximum of 7.1 channels.

- **SB SP SINGLE**

If you connect only one surround back speaker, select “SB SP SINGLE”. The sound will be output to a maximum of 6.1 channels.

- **SB SP NO**

If you have not connected a surround back speaker, select “SB SP NO”.

## Tip

The “LARGE” and “SMALL” settings for each speaker determine whether the internal sound processor will cut the bass signal from that channel. When the bass is cut from a channel, the bass redirection circuitry sends the corresponding bass frequencies to the sub woofer or other “LARGE” speakers.

However, since bass sounds have a certain amount of directionality, it is best not to cut them, if possible. Therefore, even when using small speakers, you can set them to “LARGE” if you want to output the bass frequencies from that speaker. On the other hand, if you are using a large speaker, but prefer not to have bass frequencies output from that speaker, set it to “SMALL”.

If the overall sound level is lower than you prefer, set all speakers to “LARGE”. If there is not enough bass, you can use the equalizer to boost the bass levels. For details, see page 39.

## ■ FRONT DIST. (Front speaker distance)

Lets you set the distance from your listening position to the front speakers (A). If both front speakers are not placed an equal distance from your listening position, set the distance as the average distance between the front speakers.

## With only one surround back speaker.

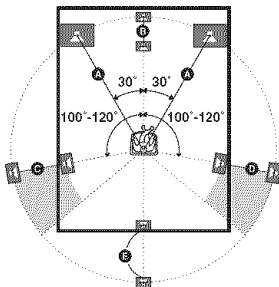

## With two surround back speakers (The angle ⑥ should be the same)

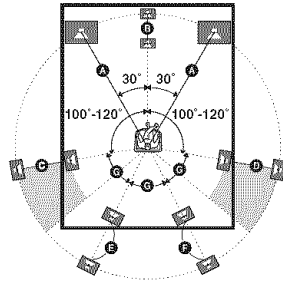

## ■ CENTER DIST. (Center speaker distance)

Lets you set the distance from your listening position to the center speaker. Center speaker distance should be set from a distance equal to the front speaker distance (A) to a distance 5 feet closer to your listening position (B).

## ■ SUR L DIST. (Surround left speaker distance)

Lets you set the distance from your listening position to the surround left speaker. Surround left speaker distance should be set from a distance equal to the front speaker distance (A) to a distance 15 feet closer to your listening position (C).

## ■ SUR R DIST. (Surround right speaker distance)

Lets you set the distance from your listening position to the surround right speaker. Surround right speaker distance should be set from a distance equal to the front speaker distance (A) to a distance 15 feet closer to your listening position (D).

## ■ S.BACK DIST. (Surround back speaker distance)<sup>a</sup>

Lets you set the distance from your listening position to the surround back speaker. Surround back speaker distance should be set from a distance equal to the front speaker distance (A) to a distance 15 feet closer to your listening position (E).

**■ SB L DIST. (Surround back left speaker distance)<sup>b)</sup>**

Lets you set the distance from your listening position to the surround back left speaker. Surround back left speaker distance should be set from a distance equal to the front speaker distance (A) to a distance 15 feet closer to your listening position (E).

**■ SB R DIST. (Surround back right speaker distance)<sup>b)</sup>**

Lets you set the distance from your listening position to the surround back right speaker. Surround back right speaker distance should be set from a distance equal to the front speaker distance (A) to a distance 15 feet closer to your listening position (F).

a) When the surround back speakers are set to "SB SP SINGLE".

b) When the surround back speakers are set to "SB SP DUAL".

**Tip**

The receiver lets you to input the speaker position in terms of distance. However, it is not possible to set the center speaker further than the front speakers. Also, the center speaker cannot be set more than 5 feet closer from the front speakers.

Likewise, the surround speakers and the surround back speaker can not be set further away from the listening position than the front speakers. And they can be no more than 15 feet closer. This is because incorrect speaker placement is not conducive to the enjoyment of surround sound.

Please note that, setting the speaker distance closer than the actual location of the speakers will cause a delay in the output of the sound from that speaker. In other words, the speaker will sound like it is further away.

For example, setting the center speaker distance 3-6 feet closer than the actual speaker position will create a fairly realistic sensation of being "inside" the screen. If you cannot obtain a satisfactory surround effect because the surround speakers are too close, setting the surround speaker distance closer (shorter) than the actual distance will create a larger sound stage.

Adjusting these parameter while listening to the sound often results in much better surround sound. Give it a try!

**■ SUR PLACEMENT (Surround speaker position)**

Lets you specify the location of your surround speakers for proper implementation of the surround effects in the Cinema Studio EX modes (page 64). This setup item is not available when the surround speakers are set to "NO" (page 49).

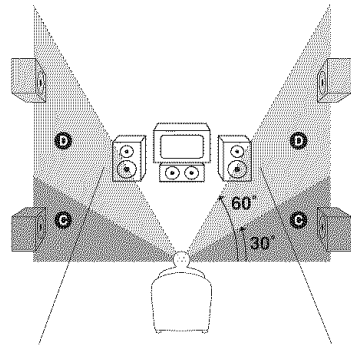
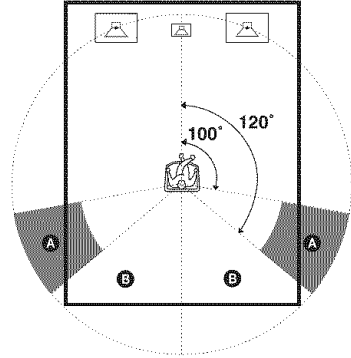

- **PL. SIDE/LOW**  
Select if the location of your surround speakers corresponds to sections A and C.
- **PL. SIDE/HIGH**  
Select if the location of your surround speakers corresponds to sections A and D.
- **PL. BEHD/LOW**  
Select if the location of your surround speakers corresponds to sections B and C.
- **PL. BEHD/HIGH**  
Select if the location of your surround speakers corresponds to sections B and D.

## Tip

Surround speaker position is designed specifically for implementation of the Cinema Studio EX modes. For other sound fields, speaker position is not so critical.

Those sound fields were designed under the premise that the surround speakers would be located behind the listening position, but presentation remains fairly consistent even with the surround speakers positioned at a rather wide angle. However, if the speakers are pointing toward the listener from the immediate left and right of the listening position, the surround effects become unclear unless set to “PL. SIDE/LOW” or “PL. SIDE/HIGH”.

Nevertheless, each listening environment has many variables, such as wall reflections, and you may obtain better results using “PL. BEHD/HIGH” if your speakers are located high above the listening position, even if they are located to the immediate left and right.

Therefore, although it may result in a setting contrary to the above explanation, we recommend that you playback multi channel surround encoded software and select the setting that provides a good sense of spaciousness and that best succeeds in forming a cohesive space between the surround sound from the surround speakers and the sound of the front speakers. If you are not sure which sounds best, select “PL. BEHD/LOW” or “PL. BEHD/HIGH” and then use the speaker distance parameter and speaker level adjustments to obtain proper balance.

## ■ CROSSOVER FREQ (Speaker crossover frequency)

Lets you set the bass crossover frequency of the speakers that have been set to “SMALL” on the SYSTEM menu. This setup item is only available when at least one speaker is set to “SMALL” and the corresponding speaker indicator flashes on the display.

## ■ DIMMER (Brightness of the display)

Lets you adjust the brightness in 3 steps.

## ■ ZONE 2 SELECT (Zone 2 source selection)

Lets you select the analog audio signals you want to output to a stereo amplifier in another room or zone.

# Calibrating the appropriate settings automatically (AUTO CAL menu)

For details, see “7: Calibrating the appropriate settings automatically (AUTO CALIBRATION)” (page 35).

# Enjoying Dolby Digital and DTS Surround sound (AUTO FORMAT DIRECT)

The Auto Format Direct (A.F.D.) mode allows you to listen to higher fidelity sound and select the decoding mode for listening to a 2 channel stereo sound as multi channel sound.

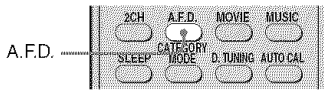

**Press A.F.D. repeatedly to select the sound field you want.**

For details, see “Types of A.F.D. mode” (page 62).

## Types of A.F.D. mode

Decoding mode	A.F.D. mode [Display]	Multi channel audio after decoding	Effect
(Detecting automatically)	A.F.D. AUTO [A.F.D. AUTO]	(Detecting automatically)	Presents the sound as it was recorded/ encoded without adding any surround effects. However, this receiver will generate a low frequency signal for output to the sub woofer when there is no LFE signals.
Dolby Pro Logic	PRO LOGIC [PRO LOGIC]	4 channel	Performs Dolby Pro Logic decoding. The source recorded in 2 channel format is decoded into 4.1 channels.
Dolby Pro Logic II	PRO LOGIC II MOVIE [PLII MOVIE]	5 channel	Performs Dolby Pro Logic II Movie mode decoding. This setting is ideal for movies encoded in Dolby Surround. In addition, this mode can reproduce sound in 5.1 channel for watching videos of overdubbed or old movies.
	PRO LOGIC II MUSIC [PLII MUSIC]	5 channel	Performs Dolby Pro Logic II Music mode decoding. This setting is ideal for normal stereo sources such as CDs.
	PRO LOGIC II GAME [PLII GAME]	5 channel	Performs Dolby Pro Logic II Game mode decoding. This setting is ideal for game softwares.
Dolby Pro Logic IIx	PRO LOGIC IIx MOVIE [PLIIX MOVIE]	7 channel	Performs Dolby Pro Logic IIx Movie mode decoding. This setting expands Dolby Pro Logic II Movie or Dolby Digital 5.1 to discrete 7.1 movie channels.
	PRO LOGIC IIx MUSIC [PLIIX MUSIC]	7 channel	Performs Dolby Pro Logic IIx Music mode decoding. This setting is ideal for normal stereo sources such as CDs.
	PRO LOGIC IIx GAME [PLIIX GAME]	7 channel	Performs Dolby Pro Logic IIx Game mode decoding.
Neo:6	Neo:6 Cinema [NEO6 CINEMA]	6 channel	Performs DTS Neo:6 Cinema mode decoding.
	Neo:6 Music [NEO6 MUSIC]	6 channel	Performs DTS Neo:6 Music mode decoding. This setting is ideal for normal stereo sources such as CDs.
(Multi Stereo)	MULTI STEREO [MULTI STEREO]	(Multi Stereo)	Outputs 2 channel left/right signals from all speakers. However, sound may not be output from certain speakers depending on the speaker settings.

## If you connect a sub woofer

This receiver will generate a low frequency signal for output to the sub woofer when there is no LFE signal, which is a low-pass sound effect output from a sub woofer to a 2 channel signal. However, the low frequency signal is not generated for “NEO6 CINEMA” or “NEO6 MUSIC” when all speakers are set to “LARGE”.

### Notes

- This function does not work when MULTI CH IN or ANALOG DIRECT is selected.
- DTS Neo:6 does not work for DTS 2CH audio, the sound is played as 2 channel.
- Dolby Pro Logic IIx decoding does not function for DTS format signals or for signals with a sampling frequency of more than 48 kHz.

### Tip

When a multi channel signal is input, only Dolby Pro Logic IIx decoding is effective. When you select decoding modes other than Dolby Pro Logic IIx, multi channel sound (being encoded) is output.

## Selecting a pre-programmed sound field

You can take advantage of surround sound simply by selecting one of the receiver's pre-programmed sound fields. They bring the exciting and powerful sound of movie theaters and concert halls into your home.

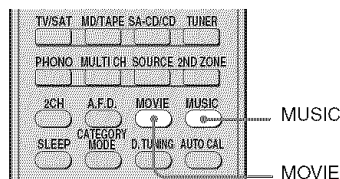

**Press MOVIE repeatedly to select a sound field for movies or press MUSIC repeatedly to select a sound field for music.**

For details, see “Types of sound field available” (page 64).

## Types of sound field available

Sound field for	Sound field [Display]	Effect
Movie	CINEMA STUDIO EX A <b>DCS</b> [CINEMA ST. EX A]	Reproduces the sound characteristics of the Sony Pictures Entertainment "Cary Grant Theater" cinema production studio. This is a standard mode, great for watching almost any type of movie.
	CINEMA STUDIO EX B <b>DCS</b> [CINEMA ST. EX B]	Reproduces the sound characteristics of the Sony Pictures Entertainment "Kim Novak Theater" cinema production studio. This mode is ideal for watching science-fiction or action movies with lots of sound effects.
	CINEMA STUDIO EX C <b>DCS</b> [CINEMA ST. EX C]	Reproduces the sound characteristics of the Sony Pictures Entertainment scoring stage. This mode is ideal for watching musicals or films where orchestra music is featured in the soundtrack.
Music	PORTABLE AUDIO [PORTABLE AUDIO]	Reproduces a clearer sound image from your portable audio device. (This mode is ideal for MP3 and other compressed music)
	HALL [HALL]	Reproduces the acoustics of a classical concert hall.
	JAZZ CLUB [JAZZ CLUB]	Reproduces the acoustics of a jazz club.
	LIVE CONCERT [LIVE CONCERT]	Reproduces the acoustics of a 300-seat live house.
Headphone	HEADPHONE 2CH [HP 2CH]	This mode is selected automatically if you use headphone when 2 channel mode (page 66)/A.F.D. mode (page 62) is selected. Standard 2 channel stereo sources completely bypass the sound field processing and multi channel surround formats are downmixed to 2 channels.
	HEADPHONE DIRECT [HP DIRECT]	Outputs the analog signals without processing by the equalizer, sound field, etc.
	HEADPHONE MULTI [HP MULTI]	This mode is selected automatically if you use headphone when MULTI CH IN is selected. Outputs the front analog signals from the MULTI CH IN jacks.
	HEADPHONE THEATER <b>DCS</b> [HP THEATER]	This mode is selected automatically if you use headphone when sound field for movie/music is selected. It allows you to experience a theater-like environment while listening through a pair of headphones.



## About DCS (Digital Cinema Sound)

Sound fields with **DCS** mark use DCS technology.

DCS is a unique sound reproduction technology for home theater developed by Sony, in cooperation with Sony Pictures Entertainment, for enjoying the exciting and powerful sound of movie theaters at home. With this “Digital Cinema Sound” developed by integrating a DSP (Digital signal processor) and measured data, the ideal sound field intended by film makers can be experienced at home.

## About CINEMA STUDIO EX modes

CINEMA STUDIO EX modes are suitable for watching motion picture DVDs (etc.), with multi channel surround effects. You can reproduce the sound characteristics of Sony Pictures Entertainment’s dubbing studio in your home.

The CINEMA STUDIO EX modes consist of the following three elements.

- **Virtual Multi Dimension**  
Creates 5 sets of virtual speakers from a single pair of actual surround speakers.
- **Screen Depth Matching**  
Creates the sensation that the sound is coming from inside the screen like in theaters.
- **Cinema Studio Reverberation**  
Reproduces the type of reverberation found in theaters.





The CINEMA STUDIO EX modes integrate these three elements simultaneously.

## Notes

- The effects provided by the virtual speakers may cause increased noise in the playback signal.
- When listening with sound fields that employ the virtual speakers, you will not be able to hear any sound coming directly from the surround speakers.
- This function does not work in the following cases:
  - MULTI CH IN or ANALOG DIRECT is selected.
  - For signals with a sampling frequency of more than 48 kHz.
- The surround back decoding mode does not function when a sound field for movie or music is selected (page 53).
- When one of the following sound fields is selected, no sound is output from the sub woofer if all the speakers are set to “LARGE” on the SYSTEM menu. However, the sound will be output from the sub woofer if the digital input signal contains LFE signals, or if the front or surround speakers are set to “SMALL”.
  - HALL
  - JAZZ CLUB
  - LIVE CONCERT

## Tip

You can identify the encoding format of DVD software, etc., by looking at the logo on the package.

-  : Dolby Digital discs
-   : Dolby Surround encoded programs
-  : DTS Digital Surround encoded programs

## To turn off the surround effect for movie/music

Press 2CH to select “2CH STEREO” or press A.F.D. repeatedly to select “A.F.D. AUTO”.

## Using only the front speakers (2CH STEREO)

In this mode, the receiver outputs the sound from the front left/right speakers only. There is no sound from the sub woofer.

Standard 2 channel stereo sources completely bypass the sound field processing and multi channel surround formats are downmixed to 2 channel.

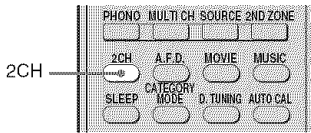

Press 2CH.

### Note

No sound is output from the sub woofer in the 2CH STEREO mode. To listen to 2 channel stereo sources using the front left/right speakers and a sub woofer, select "A.F.D. AUTO" (page 62).

## Listening to the sound without any adjustment (ANALOG DIRECT)

You can switch the audio of the selected input to two channel analog input. This function enables you to enjoy high quality analog sources.

When using this function, only the volume and front speaker balance can be adjusted.

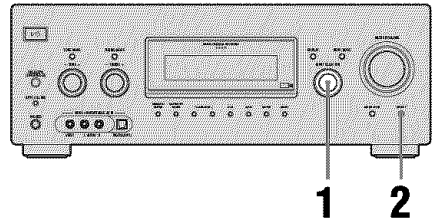

- 1 Turn INPUT SELECTOR on the receiver to select the input you want to listen to in analog audio.**

You can also use the input buttons on the remote.

- 2 Press DIRECT on the receiver.**

The analog audio is output.

### Note

When headphone is connected, "HP DIRECT" appears on the display.

# Resetting sound fields to the initial settings

Be sure to use the buttons on the receiver for this operation.

**1,2**

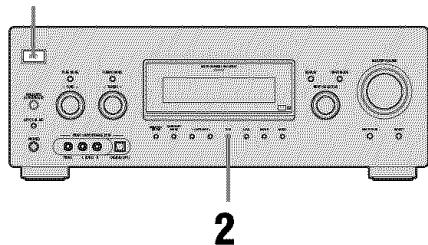

**1** Press I/O to turn off the power.

**2** While holding down 2CH, press I/O.

“S.F. INITIALIZE” appears on the display and all sound fields are reset to their initial setting.

## Tuner Operations

### Listening to FM/AM radio

You can listen to FM and AM broadcasts through the built-in tuner. Before operation, make sure you have connected the FM and AM antennas to the receiver (page 32).

#### Tip

The tuning scale for direct tuning differs depending on the area code as shown in the following table. For details on area codes, see page 3.

Area code	FM	AM
U, CA	100 kHz	10 kHz*

\* The AM tuning scale can be changed (page 98).

## Automatic tuning

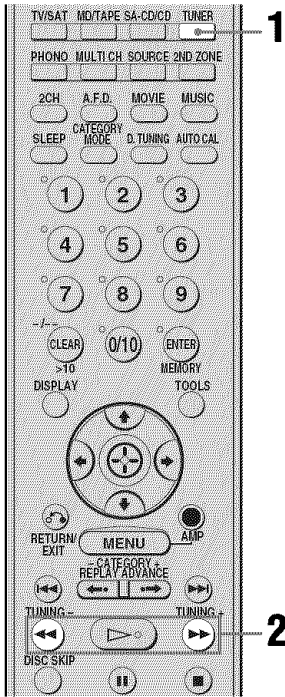

- 1 Press TUNER repeatedly to select the FM or AM band.**
- 2 Press TUNING + or TUNING –.**  
Press TUNING + to scan from low to high; press TUNING – to scan from high to low.  
The receiver stops scanning whenever a station is received.

## Using the controls on the receiver

- 1 Turn INPUT SELECTOR to select the FM or AM band.**
- 2 Press TUNING MODE repeatedly to select “AUTO TUNING”.**
- 3 Turn TUNING +/-.**

## In case of poor FM stereo reception

If the FM stereo reception is poor and “STEREO” flashes on the display, select monaural audio so that the sound will be less distorted.

For details, “Settings for the tuner (TUNER menu)” (page 54)

## Direct tuning

Enter the frequency of a station directly by using the numeric buttons.

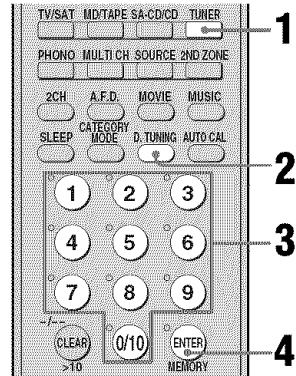

- 1 Press TUNER repeatedly to select the FM or AM band.**  
You can also use INPUT SELECTOR on the receiver.
- 2 Press D.TUNING.**
- 3 Press the numeric buttons to enter the frequency.**

Example 1: FM 102.50 MHz

Select 1 → 0 → 2 → 5 → 0

Example 2: AM 1,350 kHz

Select 1 → 3 → 5 → 0

If you have tuned in an AM station, adjust the direction of the AM loop antenna for optimum reception.

## 4 Press ENTER.

You can also use MEMORY/ENTER on the receiver.

## If you cannot tune in a station

Make sure you have entered the right frequency. If not, repeat steps 2 to 4. If you still cannot tune in a station, the frequency is not used in your area.

## Presetting radio stations

You can preset up to 30 FM stations and 30 AM stations. Then you can easily tune in the stations you often listen to.

### Presetting radio stations

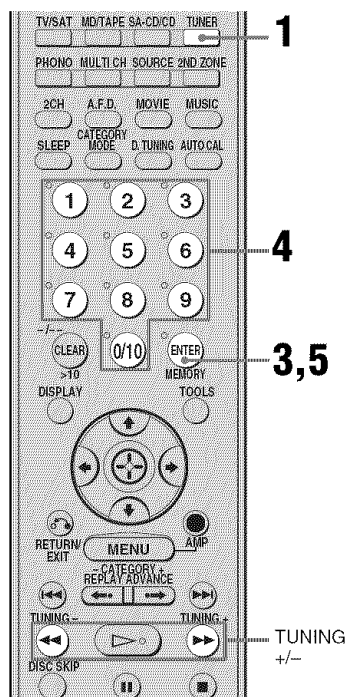

## 1 Press TUNER repeatedly to select the FM or AM band.

You can also use INPUT SELECTOR on the receiver.

## 2 Tune in the station that you want to preset using Automatic Tuning (page 68) or Direct Tuning (page 68).

Switch the FM reception mode, if necessary (page 68).

### 3 Press MEMORY.

You can also use MEMORY/ENTER on the receiver.  
“MEMORY” lights up for a few seconds.  
Perform steps 4 and 5 before “MEMORY” goes out.

### 4 Press the numeric buttons to select a preset number.

You can also press TUNING + or TUNING – to select a preset number.  
If “MEMORY” goes out before you select the preset number, start again from step 3.

### 5 Press ENTER.

You can also use MEMORY/ENTER on the receiver.  
The station is stored as the selected preset number.  
If “MEMORY” goes out before you press MEMORY, start again from step 3.

### 6 Repeat steps 1 to 5 to preset another station.

## Tuning to preset stations

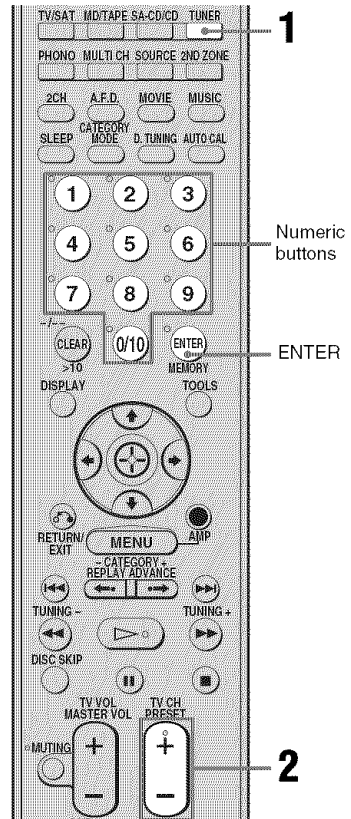

**1** Press TUNER repeatedly to select the FM or AM band.

**2** Press PRESET + or PRESET – repeatedly to select the preset station you want.

Each time you press the button, you can select a preset station as follows:

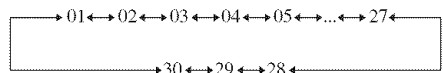

You can also press the numeric buttons to select the preset station you want. Then, press ENTER to enter the selection.

## Using the controls on the receiver

- 1 Turn INPUT SELECTOR to select the FM or AM band.
- 2 Press TUNING MODE repeatedly to select “PRESET TUNING”.
- 3 Turn TUNING +/- to select the preset station you want.

## Naming preset stations

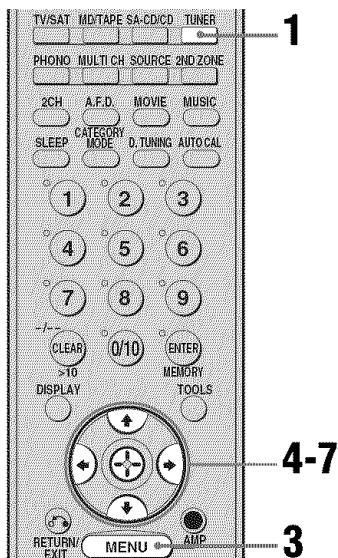

- 1 Press TUNER repeatedly to select the FM or AM band.  
You can also use INPUT SELECTOR on the receiver.
- 2 Tune in the preset station you want to create an index name for (page 70).
- 3 Press AMP, and then press MENU.  
“1-LEVEL SET” appears on the display.

- 4 Press control button  $\uparrow/\downarrow$  repeatedly to select “4-TUNER SET”.
- 5 Press the control button or control button  $\rightarrow$  to enter the menu.
- 6 Press control button  $\uparrow/\downarrow$  repeatedly to select “NAME IN”.
- 7 Press the control button or control button  $\rightarrow$  to enter the parameter.

The cursor flashes and you can select a character. Follow the procedure given in “To create an index name” below.

### To return to the previous display

Press control button  $\leftarrow$ .

### To create an index name

- 1 Use control button  $\uparrow/\downarrow/\leftarrow/\rightarrow$  to create an index name.  
Press control button  $\uparrow/\downarrow$  to select a character, then press control button  $\leftarrow/\rightarrow$  to move the cursor to the next position.

### If you made a mistake

Press control button  $\leftarrow/\rightarrow$  until the character you want to change flashes, then press control button  $\uparrow/\downarrow$  to select the correct character.

### Tip

You can select the character type as follows by pressing control button  $\uparrow/\downarrow$ .  
Alphabet (upper case)  $\rightarrow$  Numbers  $\rightarrow$  Symbols

- 2 Press the control button.  
The entered name is registered.

# Listening to the XM Radio

XM Radio is the satellite radio service with millions of listeners across the U.S. Broadcasting live daily, XM Radio offers 160 digital radio channels offering music, news, sports, comedy, talk, entertainment, traffic and weather reports, with high quality digital sound.

XM \$12.95 monthly service subscription sold separately. XM Connect and Play™ antenna required to receive XM service (sold separately). Installation costs and other fees and taxes, including a one-time activation fee may apply. Subscription fee is consumer only. All fees and programming subject to change. Channels with frequent explicit language are indicated with an XL. Channel blocking is available for XM radio receivers by calling 1-800-XMRADIO. Subscriptions subject to Customer Agreement available at [xmradio.com](http://xmradio.com). XM service only available in the 48 contiguous United States. XM Ready and XM Connect-and-Play are trademarks of XM Satellite Radio Inc. © 2006 XM Satellite Radio Inc. All rights reserved.

## Activate XM Service:

Find the 8-character XM Radio ID of the Connect-and-Play antenna. Record the Radio ID here for reference: □□□□□□□□. (Note: The XM Radio ID does not use the letters I, O, S, or F).

To check the ID of your antenna, see “Checking the XM Radio ID” on page 73.

Activate your XM Satellite Radio service online at <http://activate.xmradio.com> or by calling 1-800-XMRADIO (1-800-967-2346). You will need a major credit card.

XM will send a signal from the satellites to activate the full channel lineup. Activation normally takes 10 to 15 minutes, but during peak busy periods, you may need to keep your player on for up to an hour. When you can access the full channel lineup on your player, you're done.

## Note

Residents in Canada please see information about XM Canada at the following webpage: (<http://www.xmradio.ca/>)

## Connecting the XM Radio

Before operating the system, connect the XM Connect-and-Play antenna to the XM jack.

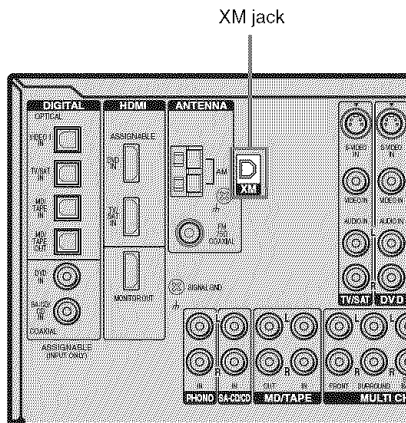

## Note

To ensure optimal reception of XM's satellite signal, move your antenna to various window locations around your home to see where the best reception will be received. Most XM customers place the antenna in a south-facing window with a clear view to the sky.



## Checking the XM Radio ID

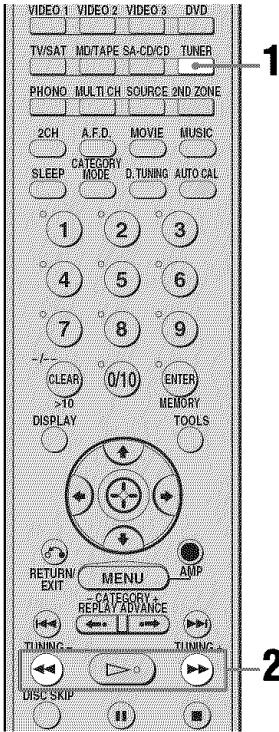

### 1 Press TUNER repeatedly to select “XM RADIO”.

You can also use INPUT SELECTOR on the receiver.

### 2 Press TUNING + or TUNING – to select channel 0.

You can also press TUNING MODE on the receiver to select “AUTO TUNING”, and then turn TUNING +/- to select channel 0.

### 3 Check the XM Radio ID on the display and write it in the space provided here.

ID: \_\_\_\_\_

If you cannot read the characters or numbers on the display clearly, refer to the following table.

Display	Description
2	2 (two)
5	5 (five)
6	6 (six)
8	8 (eight)
0	0 (zero)
A	A
B	B
D	D
G	G
H	H
K	K
M	M
Q	Q
Z	Z

## Receiving XM Radio broadcasts

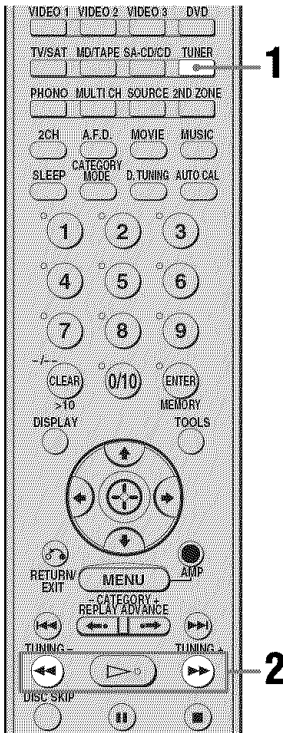

- 1 Press TUNER repeatedly to select “XM RADIO”.**

You can also use INPUT SELECTOR on the receiver.

- 2 Press TUNING + or TUNING – to select channel 0.**

You can also press TUNING MODE on the receiver to select “AUTO TUNING”, and then turn TUNING +/- to select a channel.

## Selecting channels from a category (CATEGORY TUNING)

You can select a channel from one category or all the categories by changing the category mode.

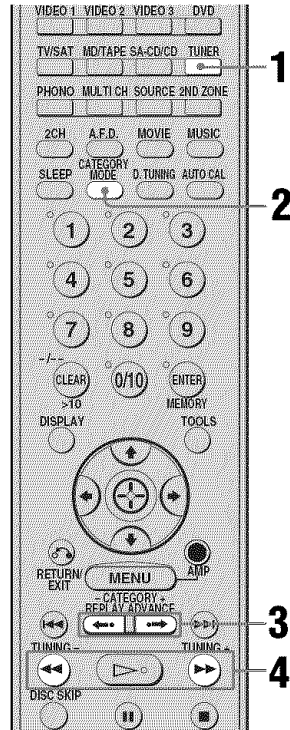

- 1 Press TUNER repeatedly to select “XM RADIO”.**

You can also use INPUT SELECTOR on the receiver.

- 2 Press CATEGORY MODE repeatedly to select the “ONE CAT”.**

- ALL CAT : You can select a channel from all categories. The initial setting is “ALL CAT”
- ONE CAT : You can select a channel from one category. “CAT” is lights up on the display when you set to “ONE CAT” mode.

- 3 Press **CATEGORY +** or **CATEGORY -** to select the category you want.

The category is selected and the channel with the lowest number in the specified category is selected.

- 4 Press **TUNING +** or **TUNING -** to select the channel.

You can also press **TUNING MODE** on the receiver to select "AUTO TUNING", and then turn **TUNING +/-** to select the channel.

### Notes

- When you select a channel in the "ONE CAT" mode, the channel you selected may not be the one in the category you want. This is because one channel may belong to more than one category.
- If you press **CATEGORY +** or **CATEGORY -** in the "ALL CAT" mode, the first channel of the next or previous category is selected (**CATEGORY SKIP**).

## Selecting channels by inputting the channel number directly (DIRECT TUNING)

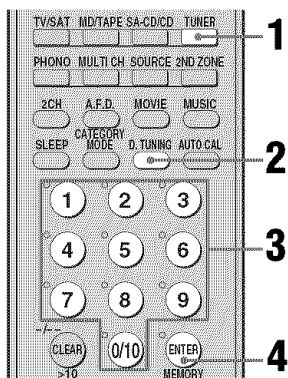

- 1 Press **TUNER** repeatedly to select "XM RADIO".

You can also use **INPUT SELECTOR** on the receiver.

- 2 Press **D.TUNING**.

- 3 Press the numeric buttons to enter the channel number.

- 4 Press **ENTER**.

You can also use **MEMORY/ENTER** on the receiver.

The selected channel is tune in.

## Displaying the XM-RADIO information on the front panel display

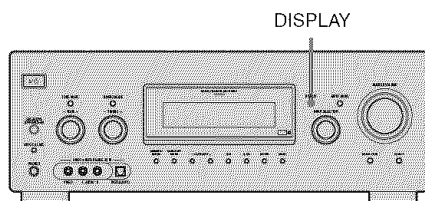

- Press **DISPLAY** on the receiver repeatedly.

Each time you press **DISPLAY** while tuning in the channel, the display changes cyclically as follows;

Channel name → Channel number →  
 Category name → Artist name/Feature →  
 Song/Program title → Sound field type

### Tip

The preset number is always displayed at the right end of the display.

# Presetting XM Radio stations

You can select the channels you want directly by presetting them using the preset numbers. You can preset up to 30 XM Radio channels.

## Presetting channels using the preset numbers

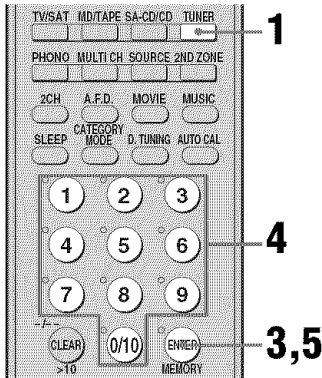

### 1 Press TUNER repeatedly to select “XM RADIO”.

You can also use INPUT SELECTOR on the receiver.

### 2 Tune in the channel you want to preset.

For details on selecting channels, see “Listening to the XM Radio” (page 72).

### 3 Press MEMORY.

You can also press MEMORY/ENTER on the receiver.

### 4 Press the numeric buttons to enter the preset number.

You can also select the number by pressing PRESET + or PRESET -. You can also turn TUNING +/- on the receiver.

Preset numbers from 1 to 30 are available, and channel 1 is preset for all the preset numbers when you purchase the receiver.

### 5 Press ENTER.

You can also press MEMORY/ENTER on the receiver.

### 6 Repeat steps 2 to 5 to preset another channel.

## Selecting the channel by using the preset numbers

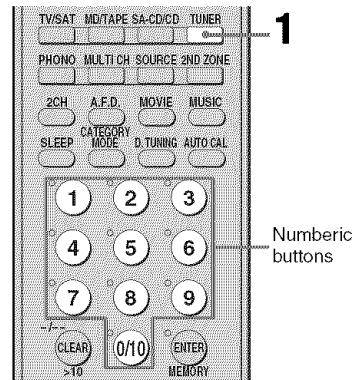

### 1 Press TUNER repeatedly to select “XM RADIO”.

You can also use INPUT SELECTOR on the receiver.

## 2 Press PRESET + or PRESET – repeatedly to select the preset channel you want.

You can also press the numeric buttons to select the preset channel you want. Then press ENTER to enter the selection. You can also press TUNING MODE on the receiver to select “PRESET TUNING”, and then turn TUNING +/- on the receiver.

You can select preset channels from 1 to 30.

### Note

The preset channel information will be updated depending on the service provided by the XM Satellite Radio Inc. that you have subscribed to.

## XM Radio messages list

Message appears	Explanation	Remedies
ANTENNA	The XM antenna is not connected or transmission is not being received properly.	Make sure that the antenna is securely connected. Try to disconnect the antenna then reconnect, or turn off the power then turn back on.
UPDATING	The encryption code is being updated.	Wait until the encryption code has been updated.
NO SIGNAL	The signal is too weak.	Make sure that the antenna is securely connected. Adjust the antenna so that the signal is as strong as possible.
LOADING	The audio channel or information is being acquired.	Wait until the audio channel or information has been acquired.
OFF AIR	The selected channel is off the air.	Make sure that you selected the channel properly. Try to select another channel.
----	There is no characteristic information such as an artist name, song title or program title available.	—
--	The preset number entered is invalid number.	Enter a number from 1 to 30.
XM ---CH	The selected channel is not available.	—

# Switching the audio input mode

## (INPUT MODE)

You can select the audio input mode by setting the audio input mode when you connect components to both digital and analog audio input jacks on the receiver.

### 1 Turn INPUT SELECTOR on the receiver to select the input.

You can also use the input buttons on the remote.

### 2 Press INPUT MODE repeatedly on the receiver to select the audio input mode.

The selected audio input mode appears on the display.

## Audio input modes

#### • AUTO 2 CH

Gives priority to digital audio signals when there are both digital and analog connections. If there are no digital audio signals, analog audio signals are selected.

#### • COAX FIXED

Specifies the digital audio signals input to the DIGITAL COAXIAL jack.

#### • OPT FIXED

Specifies the digital audio signals input to the DIGITAL OPTICAL jack.

#### • ANALOG FIXED

Specifies the analog audio signals input to the AUDIO IN (L/R) jacks.

### Note

Some audio input modes may not be set up depending on the input.

# Listening to digital sound from other inputs

## (DIGITAL ASSIGN)

You can reassign a digital audio input to another input. This function is convenient in the following example.

### When you have two DVD players and no digital audio input jack is available for the second DVD player.

Connect the first DVD player to the DVD COAXIAL IN jack on the receiver. You can connect the second DVD player to the TV/SAT OPTICAL IN jack and its analog audio/video output jacks to the VIDEO 2 AUDIO IN and VIDEO IN jacks on the receiver. Then, reassign the DVD COAXIAL's digital audio input to DVD (DVD-DVD) and the TV/SAT OPTICAL's digital audio input to VIDEO 2 (TV/SAT-VIDEO 2).

### 1 Press AMP and then press MENU.

"1-LEVEL SET" appears on the display.

### 2 Press control button $\uparrow/\downarrow$ repeatedly to select "5-AUDIO SET."

### 3 Press the control button or control button $\rightarrow$ to enter the menu.

### 4 Press control button $\uparrow/\downarrow$ repeatedly to select "DIGITAL ASSIGN".

### 5 Press the control button or control button $\rightarrow$ to enter the parameter.

**6** Press control button  $\uparrow/\downarrow$  repeatedly to select the digital audio input you want to reassign.

**7** Press the control button or control button  $\rightarrow$  to enter your selection.

**8** Press control button  $\uparrow/\downarrow$  repeatedly to select the input you want the digital audio input selected in step 6 to be reassigned to.

The input you can reassign to varies for each digital audio input. For details, see “Assignable inputs for digital audio input” below.

**To return to the previous display**

Press control button  $\leftarrow$ .

## Assignable inputs for digital audio input

Digital audio input	Assignable inputs	Display
VIDEO 1 OPT	VIDEO 1	VIDEO 1-VIDEO 1
	VIDEO 2	VIDEO 1-VIDEO 2
	DVD	VIDEO 1-DVD
	SA-CD/CD	VIDEO 1-SA-CD
VIDEO 3 OPT	VIDEO 2	VIDEO 3-VIDEO 2
	VIDEO 3	VIDEO 3-VIDEO 3
	DVD	VIDEO 3-DVD
	SA-CD/CD	VIDEO 3-SA-CD
DVD COAX	VIDEO 1	DVD-VIDEO 1
	VIDEO 2	DVD-VIDEO 2
	VIDEO 3	DVD-VIDEO 3
	DVD	DVD-DVD
	TV/SAT	DVD-TV/SAT
	MD/TAPE	DVD-MD/TAPE
TV/SAT OPT	VIDEO 2	TV/SAT-VIDEO 2
	DVD	TV/SAT-DVD
	TV/SAT	TV/SAT-TV/SAT
	SA-CD/CD	TV/SAT-SA-CD
MD/TAPE OPT	VIDEO 2	MD/TAPE-VIDEO 2
	DVD	MD/TAPE-DVD
	MD/TAPE	MD/TAPE-MD/TAPE
	SA-CD/CD	MD/TAPE-SA-CD
SA-CD/CD COAX	VIDEO 1	SA-CD-VIDEO 1
	VIDEO 2	SA-CD-VIDEO 2
	VIDEO 3	SA-CD-VIDEO 3
	TV/SAT	SA-CD-TV/SAT
	SA-CD/CD	SA-CD-SA-CD
	MD/TAPE	SA-CD-MD/TAPE

### Notes

- You cannot reassign several digital audio inputs to the same input.
- You cannot use the digital audio input for the original input when it is reassigned to another input.
- When you reassign the digital audio input, the INPUT MODE setting may change automatically (page 78).
- You cannot reassign the digital audio input to TUNER and PHONO.

# Watching component images from other inputs (COMPONENT VIDEO ASSIGN)

You can reassign a component video input to another input.

- 1 Press AMP and then press MENU.**  
“1-LEVEL SET” appears on the display.
- 2 Press control button  $\uparrow/\downarrow$  repeatedly to select “6-VIDEO SET”.**
- 3 Press the control button or control button  $\rightarrow$  to enter the menu.**
- 4 Press control button  $\uparrow/\downarrow$  repeatedly to select “COMPO V. ASSIGN”.**
- 5 Press the control button or control button  $\rightarrow$  to enter the parameter.**
- 6 Press control button  $\uparrow/\downarrow$  repeatedly to select the component video input you want to reassign (for example, DVD).**
- 7 Press the control button or control button  $\rightarrow$  to enter your selection.**

- 8 Press control button  $\uparrow/\downarrow$  repeatedly to select the input you want the component video input selected in step 6 to be reassigned to (for example, VIDEO 1).**

In this case, select “DVD-VIDEO 1”. When you press VIDEO 1, the image from the component connected to the VIDEO 1 jacks will be a component video image. The input you can reassign to varies for each component video input. For details, see “Assignable inputs for digital audio input” below.

## To return to the previous display

Press control button  $\leftarrow$ .

## Assignable inputs for digital audio input

Component video input	Assignable inputs	Display
DVD	VIDEO 1	DVD-VIDEO 1
	VIDEO 2	DVD-VIDEO 2
	VIDEO 3	DVD-VIDEO 3
	DVD	DVD-DVD
	MD/TAPE	DVD-MD/TAPE
	SA-CD/CD	DVD-SA-CD
TV/SAT	VIDEO 1	TV/SAT-VIDEO 1
	VIDEO 2	TV/SAT-VIDEO 2
	VIDEO 3	TV/SAT-VIDEO 3
	TV/SAT	TV/SAT-TV/SAT
	MD/TAPE	TV/SAT-MD/TAPE
	SA-CD/CD	TV/SAT-SA-CD

### Notes

- You cannot reassign more than one component video input to the same input.
- You cannot use the component video input as the original input when it has been reassigned to another input.



# Watching HDMI images from other inputs

## (HDMI VIDEO ASSIGN)

You can reassign an HDMI video input to another input.

- 1 Press AMP and then press MENU.**  
“1-LEVEL SET” appears on the display.
- 2 Press control button  $\uparrow/\downarrow$  repeatedly to select “6-VIDEO SET”.**
- 3 Press the control button or control button  $\rightarrow$  to enter the menu.**
- 4 Press control button  $\uparrow/\downarrow$  repeatedly to select “HDMI V. ASSIGN”.**
- 5 Press the control button or control button  $\rightarrow$  to enter the parameter.**
- 6 Press control button  $\uparrow/\downarrow$  repeatedly to select the HDMI video input you want to reassign (for example, DVD).**
- 7 Press the control button or control button  $\rightarrow$  to enter your selection.**

- 8 Press control button  $\uparrow/\downarrow$  repeatedly to select the input you want the HDMI video input selected in step 6 to be reassigned to (for example, VIDEO 1).**

In this case, select “DVD-VIDEO 1”. When you press VIDEO 1, the image from the component connected to the VIDEO 1 jacks will be a HDMI image. The sound will be output from the TV speaker. For details, see “Hooking up components with HDMI jacks” (page 30). The input you can reassign to varies for each HDMI video input. For details, see “Assignable inputs for HDMI video input” below.

### To return to the previous display

Press control button  $\leftarrow$ .

### Assignable inputs for HDMI video input

HDMI video input	Assignable inputs	Display
DVD	VIDEO 1	DVD-VIDEO 1
	VIDEO 2	DVD-VIDEO 2
	VIDEO 3	DVD-VIDEO 3
	DVD	DVD-DVD
	MD/TAPE	DVD-MD/TAPE
	SA-CD/CD	DVD-SA-CD
TV/SAT	VIDEO 1	TV/SAT-VIDEO 1
	VIDEO 2	TV/SAT-VIDEO 2
	VIDEO 3	TV/SAT-VIDEO 3
	TV/SAT	TV/SAT-TV/SAT
	MD/TAPE	TV/SAT-MD/TAPE
	SA-CD/CD	TV/SAT-SA-CD

### Notes

- You cannot reassign more than one HDMI video input to the same input.
- You cannot use the HDMI video input as the original input when it has been reassigned to another input.

## Naming inputs

You can enter a name of up to 8 characters for inputs and display it on the receiver's display. This is convenient for labeling the jacks with the names of the connected components.

**1 Press the input button to select the input you want to create an index name for.**

You can also use INPUT SELECTOR on the receiver.

**2 Press AMP and then press MENU.**

"1-LEVEL SET" appears on the display.

**3 Press control button  $\uparrow/\downarrow$  repeatedly to select either "5-AUDIO SET" or "6-VIDEO SET".**

**4 Press the control button or control button  $\rightarrow$  to enter the menu.**

**5 Press control button  $\uparrow/\downarrow$  to select "NAME IN".**

**6 Press the control button or control button  $\rightarrow$  to enter the parameter.**

The cursor flashes and you can select a character. Follow the procedure given in "To create an index name" (page 71).

**To return to the previous display**

Press control button  $\leftarrow$ .

## Changing the display

You can check the sound field, etc., by changing the information on the display. Be sure to use the buttons on the receiver for this operation.

**Press DISPLAY repeatedly.**

Each time you press the button, the display changes cyclically as follows.

**All inputs except the FM and AM band and XM Radio**

Index name of the input<sup>a)</sup>  $\rightarrow$  Selected input  
 $\rightarrow$  Sound field currently applied

**FM and AM band**

Preset station name<sup>a)</sup>  $\rightarrow$  Frequency  $\rightarrow$  Sound field currently applied

**XM Radio**

Channel name  $\rightarrow$  Channel number  $\rightarrow$   
Category name  $\rightarrow$  Artist name/Feature  $\rightarrow$   
Song/program title  $\rightarrow$  Sound field currently applied

<sup>a)</sup> Index name appears only when you have assigned one to the input or preset station (page 71, 82). Index name does not appear when only blank spaces have been entered, or it is the same as the input name.

## Using the Sleep Timer

You can set the receiver to turn off automatically at a specified time.

**Press SLEEP repeatedly while the power is on.**

Each time you press the button, the display changes cyclically as follows:

2-00-00 → 1-30-00 → 1-00-00 → 0-30-00  
→ OFF

When Sleep Timer is being used, "SLEEP" lights up on the display.

### Tip

To check the remaining time before the receiver turns off, press SLEEP. The remaining time appears on the display. If you press SLEEP again, the sleep timer will be canceled.

## Recording using the receiver

### Recording onto a MiniDisc or audio tape

You can record onto a MiniDisc or audio tape using the receiver. See the operating instructions supplied with your MD deck or tape deck.

**1 Press one of the input buttons to select the playback component.**

You can also use INPUT SELECTOR on the receiver.

**2 Prepare the playback component for playing.**

For example, insert a CD into the CD player.

**3 Prepare the recording component.**

Insert a blank MD or tape into the recording deck and adjust the recording level.

**4 Start recording on the recording component, then start playback on the playback component.**

### Notes

- Sound adjustments do not affect the signal output from the MD/TAPE OUT jacks.
- The audio signals input to the MULTI CH IN jacks are not output from the analog AUDIO OUT jacks even when MULTI CH IN is selected. The analog audio signals of the current or previously used input are output.

## To record digital sound

Connect a component for playback to the digital audio input (OPTICAL IN) jack, and connect the recording component to the OPTICAL MD/TAPE jack.

### Recording onto a recording media

You can record from a video component using the receiver. See the operating instructions supplied with your recording component.

#### **1 Press one of the input buttons to select the playback component.**

You can also use INPUT SELECTOR on the receiver.

#### **2 Prepare the playback component for playing.**

For example, insert the video tape you want to copy into the VCR.

#### **3 Prepare the recording component.**

Insert a blank video tape, etc. into the recording component (VIDEO 1) for recording.

#### **4 Start recording on the recording component, then start playback on the playback component.**

#### Notes

- Some sources contain copy guards to prevent recording. In this case, you may not be able to record from the source.
- The audio signals input to the MULTI CH IN jacks are not output from the analog AUDIO OUT jacks even when MULTI CH IN is selected. The analog audio signals of the current or previously used input are output.

# Listening to the sound in another zone

You can enjoy sounds from a component connected to the receiver in a room (Zone 2) other than the main room. For example, you can watch the DVD in the main room and listen to the CD in the Zone 2.

## Zone 2 connections

### ① ZONE 2 AUDIO OUT jack

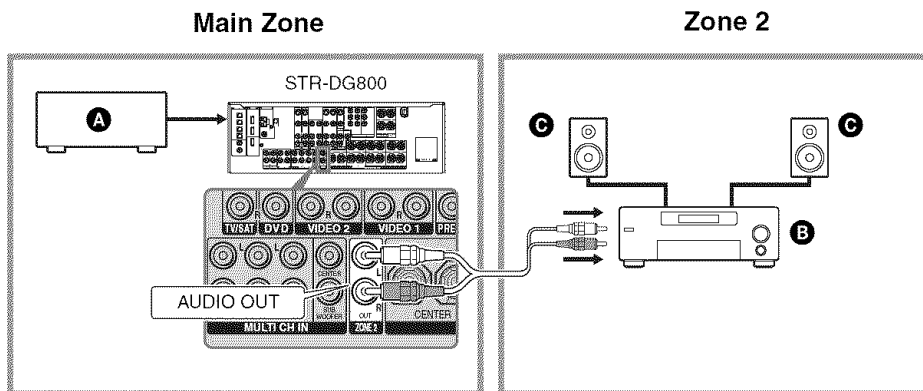

- A** Audio component
- B** Sony's Amplifier/Receiver
- C** Speaker

**Press 2ND ZONE and then press one of the audio input button (SOURCE<sup>\*1</sup>, MD/TAPE, SA-CD/CD, TUNER<sup>\*2</sup>) to select the analog audio signals you want to output.**

You can also use SOURCE to select the analog audio signals you want to output.

<sup>\*1</sup>The audio signals of the current input is output.

<sup>\*2</sup>The audio signals of the last selected TUNER function (XM/FM/AM) is output.

### Tips

- Only signals from components connected to the analog input jacks are output through the ZONE 2 OUT jacks. No signals are output from components connected to only the digital input jacks.
- When "SOURCE" is selected, the signals input to the MULTI CH IN jacks are not output from the ZONE 2 OUT jacks even when MULTI CH IN is selected. The analog audio signals of the current input are output.

### Programming the remote

You can program the remote to control non-Sony components by changing the code. Once the control signals have been memorized, you can use those components as part of your system.

Furthermore, you can also program the remote for Sony components that the remote is unable to control. Note that the remote can only control components that accept infrared wireless control signals.

#### 1 Press RM SET UP.

The RM SET UP indicator slowly flashes.

#### 2 Press the input button (including TV) for the component you want to control.

For example, if you are going to control a CD player, press SA-CD/CD. The RM SET UP indicator lights up.

#### 3 Press the numeric buttons to enter the numeric code (or one of the codes if more than one code exists) corresponding to the component and the maker of the component you want to control.

See the tables on pages 87–90 for information on the numeric code(s) corresponding to the component and the maker of the component (the first digit and the last two digits of the numeric code correspond to the category and the maker's code respectively.)

#### 4 Press ENTER.

Once the numeric code has been verified, the indicator slowly flashes twice and the remote automatically exits the programming mode.

#### 5 Repeat steps 1 to 4 to control other components.

#### To cancel programming

Press RM SET UP during any step. The remote automatically exits the programming mode.

#### To activate the input after programming

Press the programmed button to activate the input you want.

#### If programming is unsuccessful, check the following:

- If the indicator does not light up in step 1, the batteries are weak. Replace both batteries.
- If the indicator flashes 4 times in quick succession while entering the numeric code, an error has occurred. Start again from step 1.

#### Notes

- The indicator turns off while a valid button is pressed.
- In step 2, if several input buttons are pressed, only the last pressed button is valid.
- In step 3, if an input button is pressed, the new input is selected and the programming procedure returns to the beginning of step 3.
- For the numeric codes, only the last three numbers entered are valid.
- In step 2, if you press TV, you can only program the button to control a TV (page 89). If you press TUNER, you can only program the button to control a tuner (page 90).

#### To clear the memory of the remote

To clear all programmed and learned signals, do the following to reset the remote to factory settings.

#### Press I/⏻, AV I/⏻ and MASTER VOL – at the same time.

The indicator flashes 3 times, then goes off.

## The numeric codes corresponding to the component and the maker of the component

Use the numeric codes in the tables below to control non-Sony components and also Sony components that the remote is normally unable to control. Since the remote signal that a component accepts differs depending on the model and year of the component, more than one numeric code may be assigned to a component. If you fail to program your remote using one of the codes, try using other codes.

### Notes

- The numeric codes are based on the latest information available for each brand. There is a chance, however, that your component will not respond to some or all of the codes.
- All of the input buttons on this remote may not be available when used with your particular component.

### To control a CD player

Maker	Code(s)
SONY	101, 102, 103
DENON	104, 123
JVC	105, 106, 107
KENWOOD	108, 109, 110
MAGNAVOX	111, 116
MARANTZ	116
ONKYO	112, 113, 114
PANASONIC	115
PHILIPS	116
PIONEER	117
TECHNICS	115, 118, 119
YAMAHA	120, 121, 122

### To control a DAT deck

Maker	Code(s)
SONY	203
PIONEER	219

### To control an MD deck

Maker	Code(s)
SONY	301
DENON	302
JVC	303
KENWOOD	304

### To control a tape deck

Maker	Code(s)
SONY	201, 202
DENON	204, 205
KENWOOD	206, 207, 208, 209
NAKAMICHI	210
PANASONIC	216
PHILIPS	211, 212
PIONEER	213, 214
TECHNICS	215, 216
YAMAHA	217, 218

### To control an LD player

Maker	Code(s)
SONY	601, 602, 603
PIONEER	606

### To control a video CD player

Maker	Code(s)
SONY	605

### To control a DVD/VIDEO COMBO

Maker	Code(s)
SONY	411

### To control a DVD/HDD COMBO

Maker	Code(s)
SONY	403

## To control a VCR

Maker	Code(s)
SONY	701, 702, 703, 704, 705, 706
AIWA*	710, 750, 757, 758
AKAI	707, 708, 709, 759
BLAUPUNKT	740
EMERSON	711, 712, 713, 714, 715, 716, 750
FISHER	717, 718, 719, 720
GENERAL ELECTRIC	721, 722, 730
GOLDSTAR/LG	723, 753
GRUNDIG	724
HITACHI	722, 725, 729, 741
ITT/NOKIA	717
JVC	726, 727, 728, 736
MAGNAVOX	730, 731, 738
mitsubishi/MGA	732, 733, 734, 735
NEC	736
PANASONIC	729, 730, 737, 738, 739, 740
PHILIPS	729, 730, 731
PIONEER	729
RCA/PROSCAN	722, 729, 730, 731, 741, 747
SAMSUNG	742, 743, 744, 745
SANYO	717, 720, 746
SHARP	748, 749
TELEFUNKEN	751, 752
TOSHIBA	747, 756
ZENITH	754

\* If an AIWA VCR does not work even though you enter the code for AIWA, enter the code for Sony instead.

## To control a DVD player

Maker	Code(s)
SONY	401, 402, 403
RCA	414
SAMSUNG	416, 422
ZENITH	418, 420
PANASONIC	406, 408, 425
PHILIPS	407
PIONEER	409, 410
TOSHIBA	404, 421
DENON	405
BROK SONIC	424
HITACHI	416
JVC	415, 423
mitsubishi	419
ORITRON	417



## To control a TV

Maker	Code(s)
SONY	501
AIWA	501, 536, 539
AKAI	503
AOC	503
CENTURION	566
CORONADO	517
CURTIS-MATHES	503, 551, 566, 567
DAYTRON	517, 566
DAEWOO	504, 505, 506, 507, 515, 544
FISHER	508, 545
FUNAI	548
FUJITSU	528
GOLD STAR/LG	503, 512, 515, 517, 534, 544, 556, 568
GRUNDIG	511, 533, 534
HITACHI	503, 513, 514, 515, 517, 519, 544, 557, 571
ITT/NOKIA	521, 522
J.C. PENNY	503, 510, 566
JVC	516
KMC	517
MAGNAVOX	503, 515, 517, 518, 544, 566
MARANTE	527
MITSUBISHI/MGA	503, 519, 527, 544, 566, 568
NEC	503, 517, 520, 540, 544, 554, 566
NOROMENDE	530, 558
NOKIA	521, 522, 573, 575
PANASONIC	509, 524, 553, 559, 572
PHILIPS	515, 518, 557, 570, 571
PHILCO	503, 504, 514, 517, 518
PIONEER	509, 525, 526, 540, 551, 555
PORTLAND	503
QUASAR	509, 535

Maker	Code(s)
RADIO SHACK	503, 510, 527, 565, 567
RCA/PROSCAN	503, 510, 523, 529, 544
SAMSUNG	503, 515, 517, 531, 532, 534, 544, 556, 557, 562, 563, 566, 569
SAMPO	566
SANYO	508, 545, 546, 560, 567
SCOTT	503, 566
SEARS	503, 508, 510, 517, 518, 551
SHARP	517, 535, 550, 561, 565
SYLVANIA	503, 518, 566
TELEFUNKEN	530, 537, 538, 547, 549, 558
THOMSON	530, 537, 547, 549
TOSHIBA	535, 539, 540, 541, 551
ZENITH	542, 543, 567
TEKNIKA	517, 518, 567
WARDS	503, 517, 566
YORK	566
GE	503, 509, 510, 544
LOEWE	515, 534, 556

## To control a satellite tuner

<b>Maker</b>	<b>Code(s)</b>
SONY	801, 802, 803, 804, 824, 825, 865
AMSTRAD	845, 846
BskyB	862
GENERAL ELECTRIC (GE)	866
GRUNDIG	859, 860
HUMAX	846, 847
THOMSON	857, 861, 864
PACE	848, 849, 850, 852, 862, 863, 864
PANASONIC	818, 855
PHILIPS	856, 857, 858, 859, 860, 864, 874
NOKIA	851, 853, 854, 864
RCA/PROSCAN*	866, 871
BITA/HITACHI	868
HUGHES	867
JVC/Echostar/Disk Network	873
MITSUBISHI	872
SAMSUNG	875
TOSHIBA	869, 870

## To control a cable box

<b>Maker</b>	<b>Code(s)</b>
SONY	821, 822, 823
HAMLIN/REGAL	836, 837, 838, 839, 840
JERROLD/G.I.	806, 807, 808, 809, 810, 811, 812, 813, 814, 819
JERROLD	830, 831
OAK	841, 842, 843
PANASONIC	816, 826, 832, 833, 834, 835
PHILIPS	830, 831
PIONEER	828, 829
RCA	805
SCIENTIFIC ATLANTA	815, 816, 817
TOCOM/PHILIPS	830, 831
ZENITH	826, 827

## To control a tuner

<b>Maker</b>	<b>Code(s)</b>
SONY	002, 005

## To control a hard disc recorder

<b>Maker</b>	<b>Code(s)</b>
SONY	307, 308, 309

## To control a Blu-ray disc recorder

<b>Maker</b>	<b>Code(s)</b>
SONY	310, 311, 312

## To control a PSX

<b>Maker</b>	<b>Code(s)</b>
SONY	313, 314, 315

## Glossary

### ■ Component video

A format for transmitting video signal information consisting of three separate signals: luminance Y, chrominance Pb, and chrominance Pr. High quality pictures, such as DVD video or HDTV pictures, are transmitted more faithfully. The three jacks are color-coded green, blue and red.

### ■ Composite video

A standard format for transmitting video signal information. The luminance signal Y and chrominance signal C are combined and transmitted together.

### ■ Dolby Digital

Digital audio encoding/decoding technology developed by Dolby Laboratories, Inc. It consists of front (left/right), center, surround (left/right) and sub woofer channels. It is a designated audio standard for DVD-video and also known as 5.1ch surround. Since surround information is recorded and reproduced in stereo, more realistic sound with fuller presence is delivered than with Dolby surround.

### ■ Dolby Digital Surround EX

Acoustic technology developed by Dolby Laboratories, Inc. Surround back information is matrixed into regular left and right surround channels so that the sound can be reproduced in 6.1ch. Active scenes, especially, are recreated with a more dynamic and realistic sound field.

### ■ Dolby Pro Logic II

This technology converts 2ch stereo recorded audio into 5.1ch for playback. There is a MOVIE mode for movies and MUSIC mode for stereo sources such as music. Old movies encoded in the traditional stereo format can be enhanced with 5.1ch surround sound.

### ■ Dolby Pro Logic IIx

Technology for 7.1ch (or 6.1ch) playback. Along with audio encoded in Dolby Digital Surround EX, 5.1ch Dolby Digital encoded audio can be reproduced in 7.1ch (or 6.1ch). Furthermore, existing stereo recorded content can also be reproduced in 7.1ch (or 6.1ch).

### ■ Dolby Surround (Dolby Pro Logic)

Audio processing technology developed by Dolby Laboratories, Inc. Center and mono surround information is matrixed into two stereo channels. When reproduced, audio is decoded and output in 4ch surround sound. This is the most common audio processing method for DVD-video.

### ■ DTS 96/24

A high sound quality digital signal format. It records audio at a sampling frequency and bit rate of 96kHz/24bit which is the highest possible for DVD-video. The number of playback channels varies depending on the software.

### ■ DTS Neo:6

This technology converts 2ch stereo recorded audio for 6.1ch playback. There are two modes to select according to the playback source or your preference, CINEMA for movies, and MUSIC for stereo sources such as music.

### ■ DTS Digital Surround

Digital audio encoding/decoding technology for theaters developed by Digital Theater Systems, Inc. It compresses audio less than Dolby Digital, delivering a higher quality sound reproduction.

## ■ DTS-ES

Format for 6.1ch playback with surround back information. There are two modes, “Discrete 6.1” which records all channels independently, and “Matrix 6.1” which matrixes surround back channel into LS and RS channels. It is ideal for playback of motion picture soundtracks.

## ■ HDMI (High-Definition Multimedia Interface)

Technology developed by modifying the display connecting technology, DVI (Digital Visual Interface), for AV equipment. This interface can transmit video, audio, and control signals in digital format.

## ■ Sampling frequency

To convert analog audio to digital, analog data should be quantified. This process is called sampling, and the number of times per second the analog data is quantified is called the sampling frequency. A standard music CD stores data quantified at 44,100 times per second, which is expressed as a sampling frequency of 44.1 kHz. Generally speaking, a higher sampling frequency means better sound quality.

## ■ S-VIDEO signal

A format for transmitting video signal information. S-video uses a single cable and two channels, one for the Luminance signal Y and another for the chrominance signal C. Better picture quality for recording and playback than that of Composite signal is achieved.

# Precautions

## On safety

Should any solid object or liquid fall into the cabinet, unplug the receiver and have it checked by qualified personnel before operating it any further.

## On power sources

- Before operating the receiver, check that the operating voltage is identical with your local power supply.  
The operating voltage is indicated on the nameplate on the back of the receiver.
- The unit is not disconnected from the AC power source (mains) as long as it is connected to the wall outlet, even if the unit itself has been turned off.
- If you are not going to use the receiver for a long time, be sure to disconnect the receiver from the wall outlet. To disconnect the AC power cord, grasp the plug itself; never pull the cord.
- One blade of the plug is wider than the other for the purpose of safety and will fit into the wall outlet only one way. If you are unable to insert the plug fully into the outlet, contact your dealer.
- The AC power cord must be changed only at a qualified service shop.

## On heat buildup

Although the receiver heats up during operation, this is not a malfunction. If you continuously use this receiver at a large volume, the cabinet temperature of the top, side and bottom rises considerably. To avoid burning yourself, do not touch the cabinet.

## On placement

- Place the receiver in a location with adequate ventilation to prevent heat buildup and prolong the life of the receiver.
- Do not place the receiver near heat sources, or in a place subject to direct sunlight, excessive dust, or mechanical shock.
- Do not place anything on top of the cabinet that might block the ventilation holes and cause malfunctions.
- Do not place the receiver near equipment such as a television, VCR, or tape deck. (If the receiver is being used in combination with a television, VCR, or tape deck, and is placed too close to that equipment, noise may result, and picture quality may suffer. This is especially likely when using an indoor antenna. Therefore, we recommend using an outdoor antenna.)
- Use caution when placing the receiver on surfaces that have been specially treated (with wax, oil, polish, etc.) as staining or discoloration of the surface may result.

## On operation

Before connecting other components, be sure to turn off and unplug the receiver.

## On cleaning

Clean the cabinet, panel, and controls with a soft cloth slightly moistened with a mild detergent solution. Do not use any type of abrasive pad, scouring powder, or solvent, such as alcohol or benzine.

If you have any questions or problems concerning your receiver, please consult your nearest Sony dealer.

# Troubleshooting

If you experience any of the following difficulties while using the receiver, use this troubleshooting guide to help you remedy the problem.

---

### **There is no sound, no matter which component is selected, or only a very low-level sound is heard.**

- Check that the speakers and components are connected securely.
- Check that both the receiver and all components are turned on.
- Check that MASTER VOLUME is not set to “VOLUME MIN”.
- Check that the SPEAKERS (OFF/A/B/A+B) is not set to “OFF”.
- Check that headphone is not connected.
- Press MUTING to cancel the muting function.
- Check that you have selected the correct component with the input buttons.
- The protective device on the receiver has been activated. Turn off the receiver, eliminate the short-circuit problem, and turn on the power again.

---

### **There is no sound from a specific component.**

- Check that the component is connected correctly to the audio input jacks for that component.
- Check that the cord(s) used for the connection is (are) fully inserted into the jacks on both the receiver and the component.

---

**There is no sound from one of the front speakers.**

- Connect a pair of headphones to the PHONES jack to verify that sound is output from the headphones. If only one channel is output from the headphones, the component may not be connected to the receiver correctly. Check that all the cords are fully inserted into the jacks on both the receiver and the component. If both channels are output from the headphones, the front speaker may not be connected to the receiver correctly. Check the connection of the front speaker which is not outputting any sound.
- Make sure you have connected to both the L and R jacks of an analog component, and not only to either the L or R jack. Use an audio cord (not supplied).

---

**There is no sound from analog 2 channel sources.**

- Check that the INPUT MODE is not set to “COAX FIXED” or “OPT FIXED” for the selected input (page 78).
- Check that the MULTI CH IN function is not selected.

---

**There is no sound from digital sources (from COAXIAL or OPTICAL input jack).**

- Check that the INPUT MODE is not set to “ANALOG FIXED” (page 78). Check that the INPUT MODE is not set to “COAX FIXED” for the sources from the OPTICAL input jack, or to “OPT FIXED” for the sources from the COAXIAL input jack.
- Check that the MULTI CH IN function is not selected.

---

**The source sound input from the HDMI jack on the receiver is not output from the TV speaker.**

- Check the HDMI connection.
- You cannot listen to the Super Audio CD by connecting HDMI.
- Depending on the playback component, you may need to set up the component. Refer to the operating instructions supplied with the each component.

---

**The left and right sounds are unbalanced or reversed.**

- Check that the speakers and components are connected correctly and securely.
- Adjust the balance parameters using the LEVEL menu.

---

**There is severe hum or noise.**

- Check that the speakers and components are connected securely.
- Check that the connecting cords are away from a transformer or motor, and at least 10 feet away from a TV set or fluorescent light.
- Move your audio components away from the TV.
- Make sure you have grounded the  $\hbar$  SIGNAL GND terminal (only when a turntable is connected).
- The plugs and jacks are dirty. Wipe them with a cloth slightly moistened with alcohol.

---

**There is no sound, or only a very low-level sound is heard from the center/surround/surround back speakers.**

- Select a CINEMA STUDIO EX mode (page 64).
- Adjust the speaker level (page 39).
- Make sure the center/surround speakers are set to either “CTR SP/SUR SP SMALL” or “CTR SP/SUR SP LARGE” (page 49).
- Make sure the surround back speaker is set to “SB SP SINGLE” or “SB SP DUAL” (page 49).

---

**There is no sound from the surround back speaker.**

- Some discs have no Dolby Digital Surround EX flag even though the packages have Dolby Digital Surround EX logos. In this case, select “SB DEC ON” (page 48).

---

**There is no sound from the sub woofer.**

- Check that the sub woofer is connected correctly and securely.
- Make sure you have turned on your sub woofer.
- Make sure the sub woofer is set to “SUB WOOFER YES” (page 49).
- There is no sound from the sub woofer depending on the sound field.
- When all speakers are set to “LARGE” and “Neo:6 Cinema” or “Neo:6 Music” is selected, there is no sound from the sub woofer.

---

**The surround effect cannot be obtained.**

- Make sure the sound field function is on (press MOVIE, or MUSIC).
- Sound fields do not function for signals with a sampling frequency of more than 48 kHz.

---

**Dolby Digital or DTS multi channel sound is not reproduced.**

- Check that the DVD, etc. you are playing is recorded in Dolby Digital or DTS format.
- When connecting the DVD player, etc., to the digital input jacks of this receiver, check the audio setting (the settings for the audio output) of the connected component.

---

**Recording cannot be carried out.**

- Check that the components are connected correctly.
- Select the source component using the input buttons.

---

**The FM reception is poor.**

- Use a 75-ohm coaxial cable (not supplied) to connect the receiver to an outdoor FM antenna as shown below. If you connect the receiver to an outdoor antenna, ground it against lightning. To prevent a gas explosion, do not connect the ground wire to a gas pipe.

Outdoor FM antenna

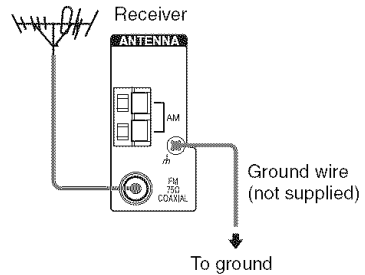

---

### **Radio stations cannot be tuned in.**

- Check that the antennas are connected securely. Adjust the antennas and connect an external antenna, if necessary.
- The signal strength of the stations is too weak (when tuning in with automatic tuning). Use direct tuning.
- Make sure you set the tuning interval correctly (when tuning in AM stations with direct tuning).
- No stations have been preset or the preset stations have been cleared (when tuning by scanning preset stations). Preset the stations (page 69).
- Press DISPLAY repeatedly on the receiver so that the frequency appears on the display.

---

### **There is no picture or an unclear picture appears on the TV screen or monitor.**

- Select the appropriate input using the input buttons.
- Set your TV to the appropriate input mode.
- Move your audio components away from the TV.
- Assign the component video input correctly.

---

### **The MULTI CHANNEL DECODING lamp does not light up in blue.**

- Check that the playback component is connected to a digital jack and the input is selected properly on this receiver.
  - Check whether the input source of the software being played back corresponds to the multi channel format.
  - Check whether the setup on the playback component is set to multi channel sound.
- 

---

## **Remote control**

---

### **The remote does not function.**

- Point the remote at the remote sensor on the receiver.
  - Remove any obstacles in the path between the remote and the receiver.
  - Replace all the batteries in the remote with new ones, if they are weak.
  - Make sure you select the correct input on the remote.
  - Check if the command modes of the receiver and the remote is the same. If the command mode of the receiver and the remote is different, you cannot operate the receiver with the remote (page 34).
- 

## **Error messages**

If there is a malfunction, the display shows a message. You can check the condition of the system by the message. Refer to the following table to solve the problem. If any problem persists, consult your nearest Sony dealer. If an error message appears while you perform Auto Calibration, see “Error and warning codes” (page 37) to solve the problem.

---

### **DECODE ERROR**

Appears when a signal the receiver cannot decode (ex. DTS-CD) is input and “DECODE PRIORITY” on the AUDIO menu is set to “DEC. PRI. PCM”. Set it to “DEC. PRI. AUTO” (page 48).

---

### **PROTECTOR**

Irregular current is output from the receiver. The receiver will automatically turn off after a few seconds. Check the speaker connection and turn on the power again.

---



## If you are unable to remedy the problem using the troubleshooting guide

Clearing the receiver's memory may remedy the problem (page 25). However, note that all memorized settings will be reset to their factory settings and you will have to readjust all settings on the receiver.

## If the problem persist

Consult your nearest Sony dealer. Note that if service personnel changes some parts during repair, these parts may be retained.

## Reference sections for clearing the receiver's memory

To clear	See
All memorized settings	page 33
Customized sound fields	page 67

## Specifications

### AUDIO POWER SPECIFICATIONS

#### POWER OUTPUT AND TOTAL HARMONIC DISTORTION: (Models of area code U only)

With 8 ohm loads, both channels driven, from 20 – 20,000 Hz; rated 100 watts per channel minimum RMS power, with no more than 0.09% total harmonic distortion from 250 milliwatts to rated output.

#### Amplifier section

Models of area code U, CA

Stereo Power Output<sup>1)</sup>, Reference Power Output<sup>1)2)</sup>

8 ohms 20 Hz – 20 kHz, THD 0.09%	100 W + 100 W, 110 W/ch
8 ohms 1 kHz, THD 0.7%	110 W + 110 W, 120 W/ch
8 ohms 1 kHz, THD 10%	125 W + 125 W, 150 W/ch

<sup>1)</sup>Measured under the following conditions:

Area code	Power requirements
U, CA	120 V AC, 60 Hz

<sup>2)</sup>Reference power output for front, center, surround and surround back. Depending on the sound field settings and the source, there may be no sound output.

## Frequency response

Analog 10 Hz – 70 kHz,  
+0.5/-2 dB (with sound  
field and equalizer  
bypassed)

## Input

Analog Sensitivity: 500 mV/  
50 kohms  
S/N<sup>3)</sup>: 96 dB  
(A, 500 mV<sup>4)</sup>)

Digital (Coaxial) Impedance: 75 ohms  
S/N: 100 dB  
(A, 20 kHz LPF)

Digital (Optical) S/N: 100 dB  
(A, 20 kHz LPF)

## Output (analog)

AUDIO OUT Voltage: 500 mV/10 kohms  
SUB WOOFER Voltage: 2 V/1 kohm

## Equalizer

Gain levels ±10 dB, 1 dB step

<sup>3)</sup>INPUT SHORT (with sound field and equalizer  
bypassed).

<sup>4)</sup>Weighted network, input level.

## FM tuner section

Tuning range 87.5 – 108.0 MHz

Intermediate frequency  
10.7 MHz

Useable sensitivity 11.2 dBf, 1 µV/75 ohms  
S/N

Mono/Stereo: 76 dB/70 dB

Harmonic distortion at 1 kHz

Mono/Stereo: 0.3%/0.5%

Separation 45 dB at 1 kHz

Frequency response 30 Hz – 15 kHz,  
+0.5/-2 dB

## AM tuner section

Tuning range

Area	Tuning scale	
<b>code</b>	10 kHz step	9 kHz step
U, CA	530 – 1,710 kHz <sup>5)</sup>	531 – 1,710 kHz <sup>5)</sup>

Intermediate frequency

450 kHz

Usable sensitivity 50 dB µ/m (at 1,000 kHz or  
999 kHz)

<sup>5)</sup>You can change the AM tuning scale to 9 kHz or  
10 kHz. After tuning in any AM station, turn off  
the receiver. While holding down CATEGORY  
MODE, press I/⏪. All preset stations will be  
erased when you change the tuning scale. To reset  
the scale to 10 kHz (or 9 kHz), repeat the  
procedure.

## Video section

Inputs/Outputs

Video: 1 Vp-p/75 ohms

S-video: Y: 1 Vp-p/75 ohms

C: 0.286 Vp-p, 75 ohms

COMPONENT VIDEO:

Y: 1 Vp-p/75 ohms

P<sub>B</sub>/C<sub>B</sub>/B-Y: 0.7 Vp-p/  
75 ohms

P<sub>R</sub>/C<sub>R</sub>/R-Y: 0.7 Vp-p/  
75 ohms

80 MHz HD Pass Through

## General

### Power requirements

Area code	Power requirements
U, CA	120 V AC, 60 Hz

### Power consumption

Area code	Power consumption
U	260 W
CA	360 VA

Power consumption (during standby mode)  
0.3 W

### AC outlets:

Area code	AC outlets
U, CA	2 switched, 120 W/ 1A MAX

### Dimensions (w/h/d) (Approx.)

430 × 157.5 × 351.5 mm  
(16 7/8 × 6 2/8 × 13 7/8  
inches) including  
projecting parts and  
controls

Mass (Approx.) 11.0 kg (24 lb 5 oz)

## Supplied accessories

FM wire antenna (1)

AM loop antenna (1)

Remote commander RM-AAP008 (1)

R6 (size-AA) batteries (2)

Optimizer microphone ECM-AC2 (1)

For details on the area code of the component you are using, see page 3.

Design and specifications are subject to change without notice.

# Index

## Symbols

⏏ SIGNAL GND terminal  
32

## Numerics

2 channel 66  
2CH STEREO 66  
5.1 channel 15  
7.1 channel 15

## A

AUTO CALIBRATION 35  
AUTO FORMAT DIRECT  
(A.F.D.) 61

## C

CD player  
connecting 17  
playback 42  
COMPONENT VIDEO  
ASSIGN 80

## D

Digital Cinema Sound  
(DCS) 65  
Dolby Digital 91  
DTS 91  
DVD player  
hooking up 23  
playback 43  
DVD recorder  
hooking up 23

## E

Error messages 96

## H

HDMI  
connecting 30

## I

Initial setup 33  
INPUT MODE 78

## M

MD deck  
connecting 17  
Menu  
AUDIO 55  
AUTO CAL 60  
LEVEL 51  
SUR 52  
SYSTEM 56  
TONE 52  
TUNER 54  
VIDEO 56

Muting 41

## N

Naming 71, 82

## R

Recording  
onto a MiniDisc or audio  
tape 83  
onto a recording media  
84

## S

Satellite tuner  
hooking up 23  
Selecting  
component 40  
sound field 63  
speaker system 35  
Sleep Timer 83  
Sound fields  
resetting 67  
selecting 63  
Speakers  
connecting 16  
Super Audio CD player  
connecting 17  
playback 42  
SUR BACK DECODING  
53

## T

Tape deck  
connecting 17  
TEST TONE 39  
Tuner  
connecting 32  
Tuning  
automatically 68  
directly 68  
to preset stations 70  
TV  
hooking up 23

## V

VCR  
hooking up 23  
Video game  
hooking up 23