

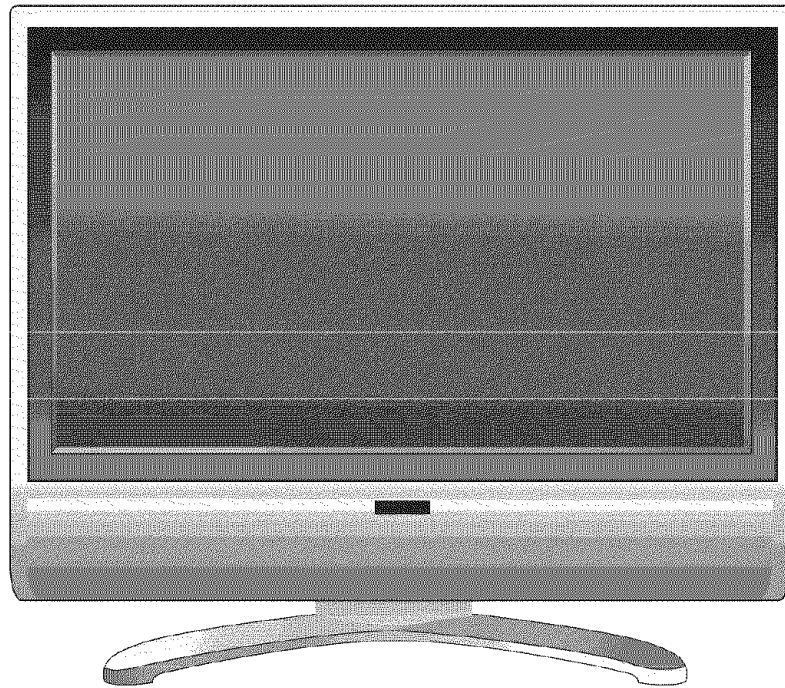

PLTV-3750

37" Liquid Crystal Display

User's Manual



Protron PLTV-3750 Liquid Crystal Display User's Manual.

© 2006 Protron Digital Corporation. All rights reserved.

Under copyright law, this manual may not be reproduced in any form, in whole or in part, without the prior written consent of Protron Digital Corporation.

Disclaimer

Protron Digital Corporation has reviewed this manual and provides it only as a guide to operation. All statements, technical information, and recommendations in this manual and in any guides or related documents are believed reliable, but the accuracy and completeness thereof are not guaranteed or warranted, and they are not intended to be, nor should they be understood to be, representations or warranties concerning the products described.

Specifications are subject to change without notice.

Trademarks

Protron is a trademark of Prosonic Group Corporation.

Protron Digital Corporation
2133 S. Green Privado
Ontario, CA 91761

Printed in China

Important Safety Instructions

1. Read these instructions.
2. Keep these instructions.
3. Heed all warnings.
4. Follow all instructions.
5. Do not use this apparatus near water.
6. Clean only with a dry cloth.
7. Do not block any ventilation openings. Install in accordance with the manufacturer's instructions.
8. Do not install near any heat sources such as radiators, heat registers, stoves, or other apparatuses (including amplifiers) that produce heat.
9. Do not defeat the safety purpose of the polarized or grounding-type plug.
A polarized plug has two blades, one wider than the other.
A grounding-type plug has two blades and a third grounding prong.
The wide blade or the third prong are provided for your safety. If the provided plug does not fit into your outlet, consult an electrician for replacement of the obsolete outlet.
10. Protect the power cord from being walked on or pinched, particularly at plugs, convenience receptacles, and the point where they exit from the apparatus.
11. Only use attachments/accessories specified by the manufacturer.
12. Use only with the cart, stand, tripod, bracket, or table specified by the manufacturer or sold with the apparatus. When a cart is used, use caution when moving the cart/apparatus combination to avoid injury from tip-over.
13. Unplug this apparatus during lightning storms or when unused for long periods of time.
14. Refer all servicing to qualified service personnel. Servicing is required when the apparatus has been damaged in any way, such as when the power supply cord or plug is damaged, liquid has been spilled or objects have fallen into the apparatus, the apparatus has been exposed to rain or moisture, the apparatus does not operate normally, or the apparatus has been dropped.
15. To reduce the risk of fire or electric shock, do not expose this appliance to rain or moisture.
16. Do not expose apparatus to dripping or splashing and do not place objects filled with liquid on the apparatus.
17. Only use apparatus with battery specified by manufacturer.



Product Cautions



TO PREVENT POSSIBLE DANGER, ELECTRIC SHOCK, AND OTHER INJURIES WHEN HANDLING YOUR DISPLAY, PLEASE BE AWARE OF ALL WARNINGS AND SAFETY PRECAUTIONS LISTED BELOW.



Never spill any liquid of any kind on the display.

Never insert anything into the display, where objects can come into contact with high voltage nodes or damage internal components.



Do not attempt to service the display yourself. Opening or removing covers exposes high voltage nodes and other hazards. Refer all servicing to qualified service personnel.



Do not touch the display or antenna during thunderstorms. Unplug the display during thunderstorms, or if it will not be used for extended periods. Failure to do so may result in electric shock or fire.

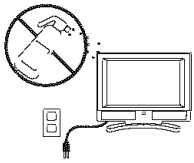

Before cleaning the display, unplug it from the wall. Use a damp cloth for cleaning. Never use liquid or aerosol cleaners.

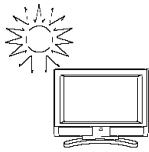

To prevent overheating and ensure reliable operation, place the display only in a well ventilated location. Avoid cramped or inadequately ventilated locations. Place the display at least 10 cm (4") from walls or other objects. Always keep the vent clean. Never place the display upside down.

Note: Read all safety and operating instructions before operating your new display.

Conformity and Compliance

FCC Compliance Statement

This equipment has been tested and found to comply with the limits for a Class B digital device, pursuant to Part 15 of the FCC Rules. These limits are designed to provide reasonable protection against harmful interference when the equipment is operated in a residential installation. This equipment generates, uses, and can radiate radio frequency energy and, if not installed and used in accordance with the instructions, may cause harmful interference to radio communications. However, there is no guarantee that interference will not occur in a particular installation. If this equipment does cause harmful interference to radio or television reception (this can be determined by turning the device off and on), the user is encouraged to try to correct the interference by one or more of the following measures:

- Reorient or relocate the receiving antenna.
- Increase the separation between the equipment and the receiver.
- Connect the equipment to an outlet on a circuit different from that to which the receiver is connected.
- Consult the dealer or an experienced radio/TV technician for help.

Caution:

To comply with the limits for an FCC Class B computing device, the user should use the shielded signal cable and power cord supplied with the unit. The FCC warns that changes or modifications of the unit not expressly approved by the party responsible for compliance could void the user's authority to operate the equipment.

Radio Frequency Interference Statement

Warning:

This is a Class B product. In a domestic environment this product may cause radio interference, in which case the user may be required to take adequate measures.

Canadian DOC Notice for Class B Computing Devices

This digital apparatus does not exceed the Class B limits for radio noise emissions from a digital apparatus as set out in the Radio Interference Regulations of the Canadian Department of Communications.

CE Marking and Declaration of Conformity

This device complies with the requirements of related European standards, which include the following:

- Emission: EN 55022, EN 61000-3-2, EN 61000-3-3
- Immunity: EN 50082-1
- Safety: EN 60950 Low-Voltage Directive (73/23/EEC)



Table of Contents

Introduction	1
Features	1
Unpacking Your New Display	2
Setting Up the Display	3
Connecting a Digital TV (HDTV) Signal Source	3
Connecting an Analog TV Signal Source	4
Connecting Composite Video Devices	4
Connecting S-Video Devices	5
Connecting Component Video Devices	5
Connecting HDMI Devices	6
Connecting to an Audio System	6
Connecting to a Video Input System	7
Connecting a PC	7
Operating the Display	9
Turning the Display On and Off	9
Selecting the Video and Audio Source	9
Adjusting the Volume	9
Selecting the Television Channel	9
Accessing the On-Screen Display	10
Using Your Display for the First Time	11
Setting up Digital Television Channels	11
Setting up Analog Television Channels	11
Using the Remote Control	13
Replacing the Remote Batteries	15
Configuring the Display	16
Video	17
Audio	17
Miscellaneous	18
TV	22
PC	22
DTV	23
Troubleshooting	26
Support Information	27
Specifications	28
General	28
Picture-in-Picture Combinations	29
Supported VGA Modes	29
Limited Warranty	30

Introduction

Congratulations on purchasing your new Protron Liquid Crystal Display!

You can use your new display as a television, in a home theater system, or even as a computer monitor. With HDMI, component, composite, and S-Video video inputs, you can connect numerous devices to your display, including DVD players, VCRs, HDTV receivers, video game systems, camcorders, and so on. And with video and audio output, you can connect your display to a home stereo system with a subwoofer, or even record what is displayed on the screen.

The built-in HDTV tuner allows you to simply connect a standard HDTV antenna to enjoy the clarity and brilliance of modern digital television.

The progressive scan HDMI and component video inputs on your display give you the highest quality video available, allowing you to enjoy crystal-clear DVDs and other media.

Features

- 37" viewable display area
- 1366 × 768 resolution
- Built-in HDTV tuner with coaxial input
- Analog TV tuner with coaxial input
- HDMI audio/video input
- 2 progressive scan component video inputs
- 3 composite video inputs
- S-Video input with optical audio input
- 6 audio inputs, one for each video input
- Composite video output
- Audio output with subwoofer output
- Surround sound simulation
- VGA computer video input
- 1/8" stereo audio input jack for computer audio
- VESA DPMS-compliant power saving—automatically turns off the display after a configurable period of inactivity
- Windows 95/98/2000/XP Plug and Play compliant
- Conforms to VESA standards and supports the DDC1 and DDC2B specifications
- Wide viewing angle
- Versatile, functional, and user-friendly On-Screen Display (OSD)

Unpacking Your New Display

Before using your new display, you should unpack the contents of the box and check to make sure everything is present and undamaged.

To unpack the display:

1. Set the box upright near the intended display location.
2. Open the top of the box.
3. Remove the accessories box from behind the display and set it aside.
4. Lift the display out of the box.
5. Remove the pads and set the display aside.

The accessories box should contain the items indicated below. If any items are missing or damaged, contact the seller immediately.

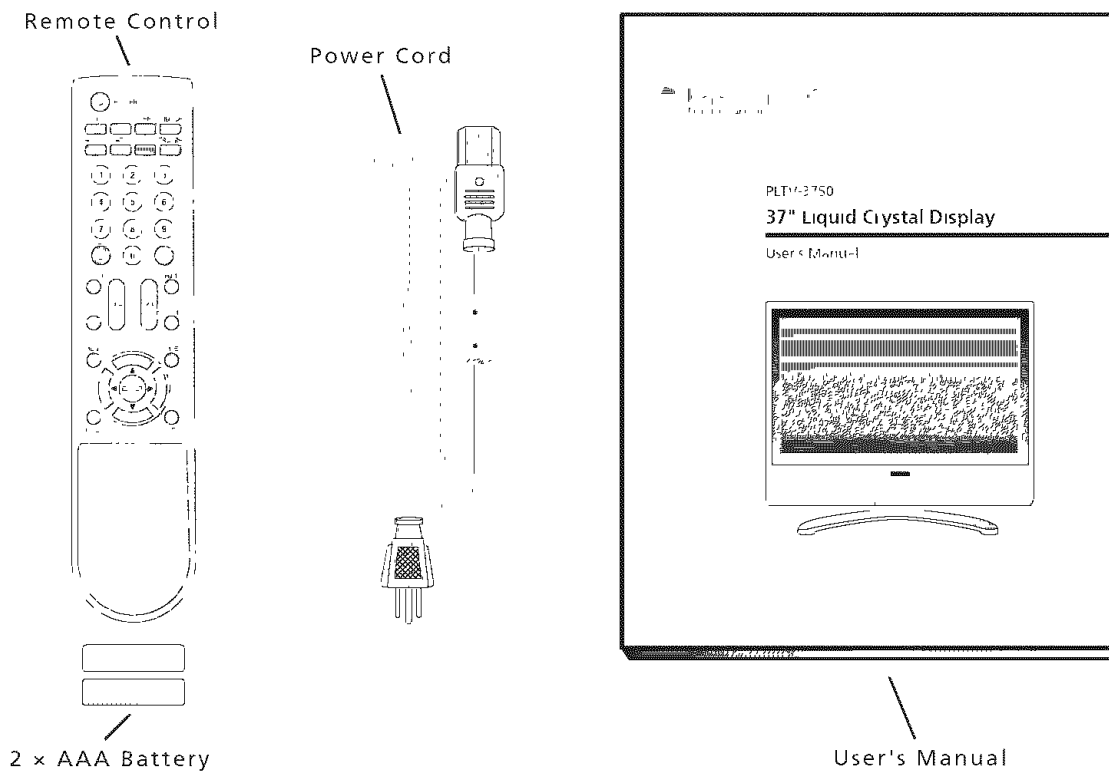
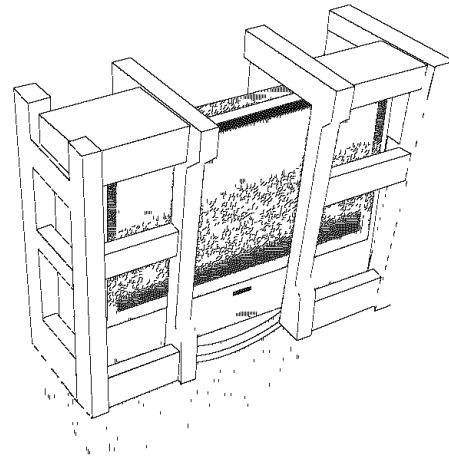

Setting Up the Display

The display requires a stable, level, and clean surface near a power outlet, 10 cm (4") away from walls or other large objects. The rear ventilation grid should be unobstructed, and the display should not be exposed to water or heat. Before setting up the display, prepare such a space.

To set up the display:

1. Remove the power cord from the accessories box, insert the appropriate end into the power (AC IN) connector on the bottom of the display, and then insert the other end into a free power outlet.

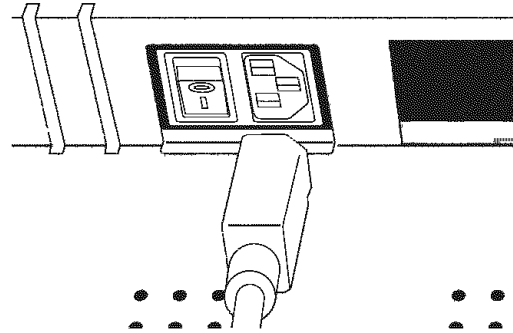

2. Turn on the power switch on the bottom of the display.

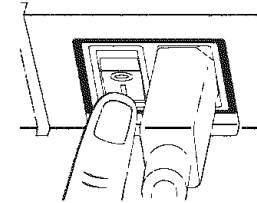

Connecting a Digital TV (HDTV) Signal Source

To connect an HDTV signal source to the display, connect a coaxial cable between the ATSC input and the TV signal source.

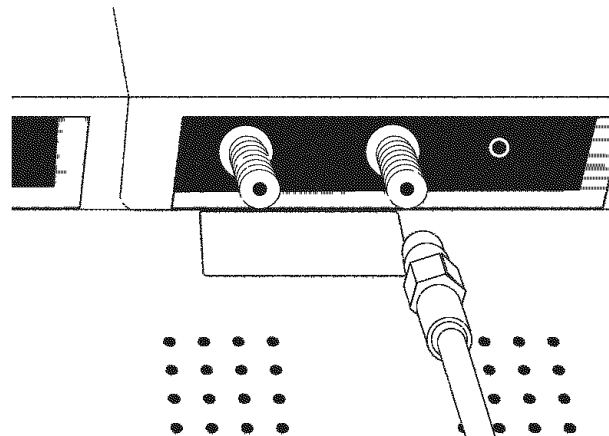

Setting Up the Display

Connecting an Analog TV Signal Source

An analog TV signal may come from a cable box, satellite receiver, antenna, or similar device.

To connect an analog TV signal source to the display, connect a coaxial cable between the ANT input and the TV signal source (for example, a cable box, satellite receiver, or antenna).

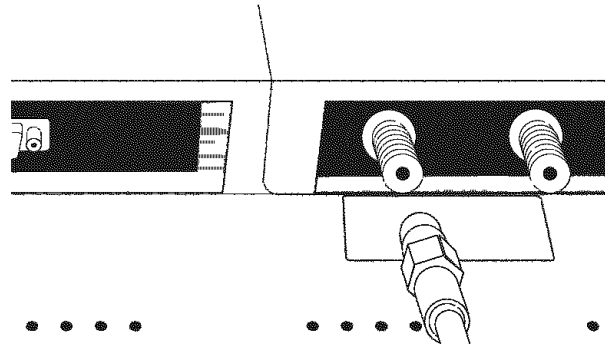

Note: If you would like to be able to record the TV signal with a VCR, DVD recorder, or similar device, connect the TV signal source to the input of the recording device with one cable, then connect the output of the recording device to the ANT jack on the display with another cable.

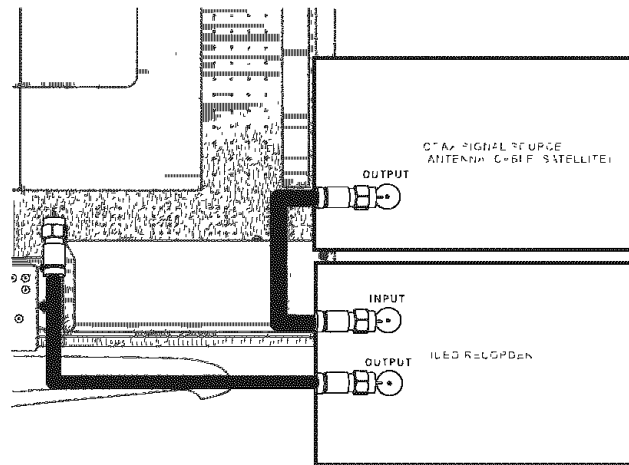

Connecting Composite Video Devices

Many video devices, such as VCRs, DVD players, video game systems, and camcorders, have composite video outputs. Composite video uses one RCA cable to transmit video information and generally provides lower quality than S-Video, component video, and HDMI (see below).

To connect a composite video source to the display:

1. Using an RCA cable, connect the composite video output (yellow) on the source device to the corresponding jack in one of the three composite video blocks on the display (AV 1 IN, AV 2 IN, or AV 3 IN).
2. Using two other RCA cables, connect the right (red) and left (white) audio outputs on the source to the corresponding jacks in the same composite video block used above.

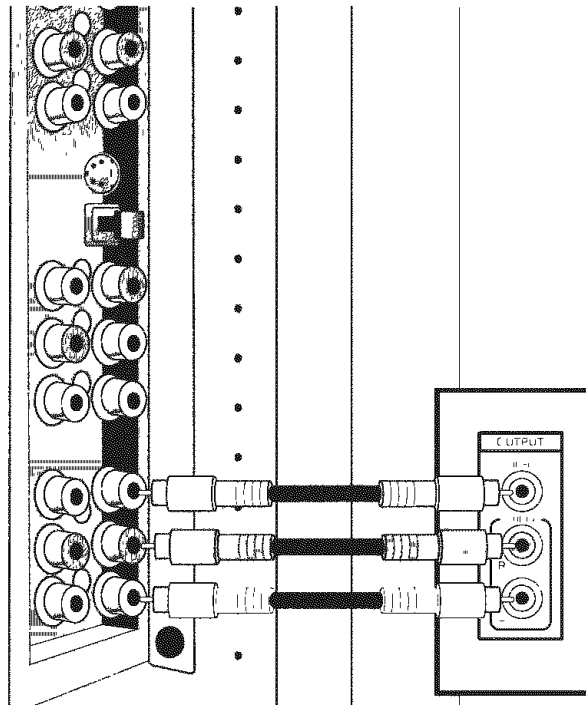

Connecting S-Video Devices

Many video devices that have composite video outputs also have S-Video outputs. S-Video uses a single four-wire cable to transmit video information. Two of the wires are used to transmit video. Because it splits the video signal into two components, S-Video generally provides higher quality than composite video, but lower quality than component video and HDMI (see below).

Note: The pins used in S-Video connectors are somewhat fragile. Take care to avoid bending the pins, as a bent or broken pin can cause loss of color information or total signal loss.

To connect an S-Video source to the display:

1. Using an S-Video cable, connect the S-Video output on the source device to the S-Video jack on the display.
2. Using two RCA cables, connect the right (red) and left (white) audio outputs on the source to the corresponding jacks in the S-Video block on the display.

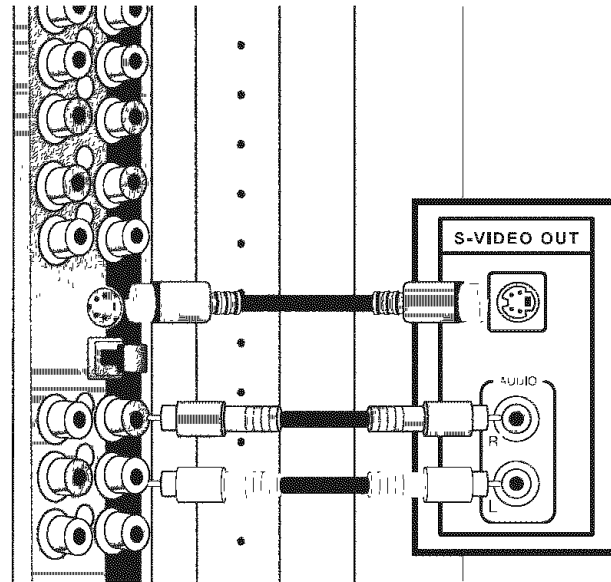

Connecting Component Video Devices

High-quality video devices, such as HDTV receivers and high-end DVD players, have component video outputs. Component video uses three RCA connections to transmit video information. Because the information is split into three signals, component video offers higher quality than composite video and S-Video.

To connect a component video source to the display:

1. Using three RCA cables, connect the three component video outputs to the corresponding jacks in one of the two component video blocks on the display.
2. Using two other RCA cables, connect the right (red) and left (white) audio outputs on the source to the corresponding jacks in the same component video block used above.

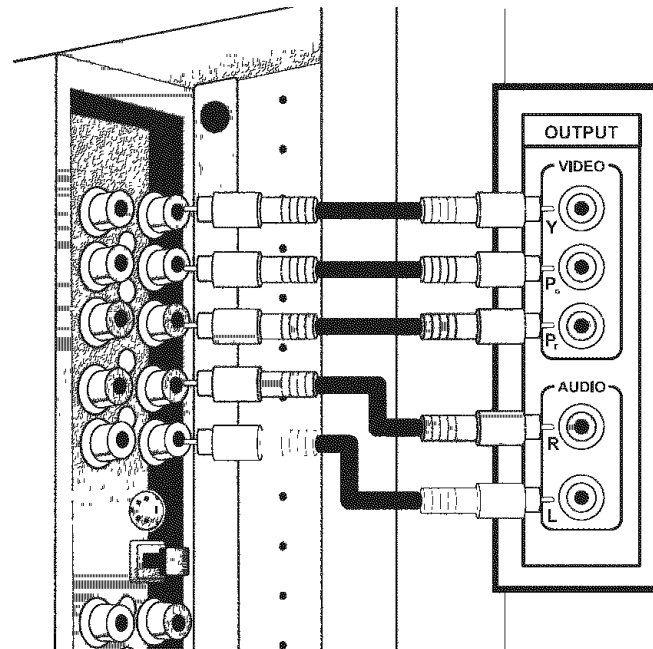

Setting Up the Display

Connecting HDMI Devices

The highest-quality video devices have HDMI outputs. An HDMI cable carries audio and progressive scan video of the highest quality.

To connect an HDMI signal source to the display, use an HDMI cable to connect the source device to the HDMI input on the bottom of the display.

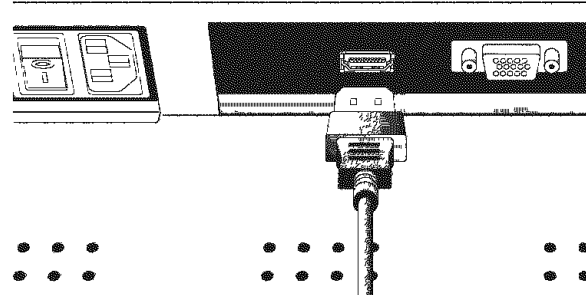

Connecting to an Audio System

Your display has audio outputs that may be used to play the display's audio on a peripheral system, such as a stereo system or a home theater system. In addition, there is a subwoofer output that can be connected to a powered (amplified) subwoofer to fill out the bass.

To connect the display to an audio system:

1. Using two RCA cables, connect the right (red) and left (white) audio outputs in the output block on the display (AV OUT) to the corresponding inputs on your audio system.
2. (OPTIONAL) If you have a powered (amplified) subwoofer, connect a third RCA cable from the SUBWOOFER output on the display to the subwoofer's (or amplifier's) input.

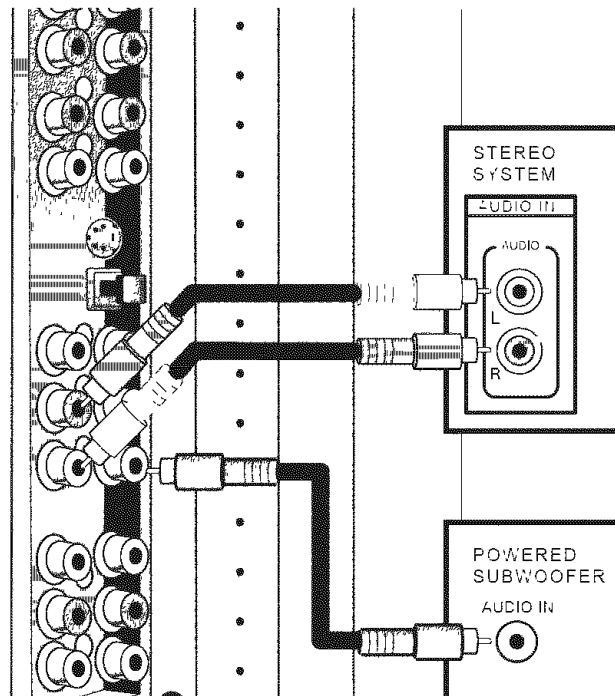

To listen to the high-quality digital audio of an HDTV transmission, instead connect the OPTICAL output to your stereo system using an optical digital cable.

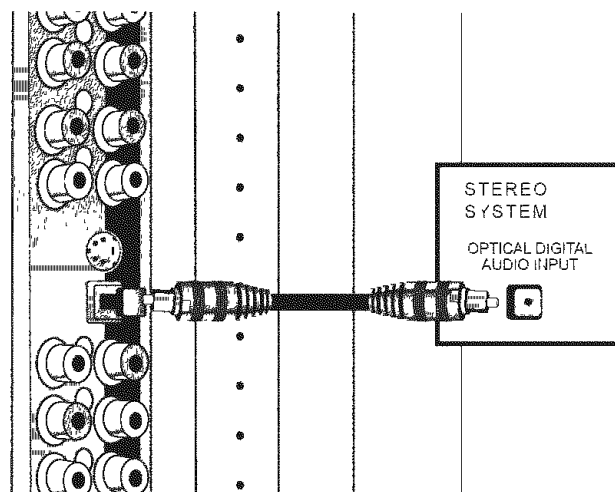

Connecting to a Video Input System

There is a composite video output on the display that may be used to transmit the currently displayed video to other video input devices, such as video recorders or other displays.

To connect the display to a video input system:

1. Using an RCA cable, connect the composite video output (yellow) in the output block on the display (AV OUT) to the corresponding jack on the video input system.
2. Using two other RCA cables, connect the right (red) and left (white) audio outputs in the AV OUT block to the corresponding inputs on the video input system.

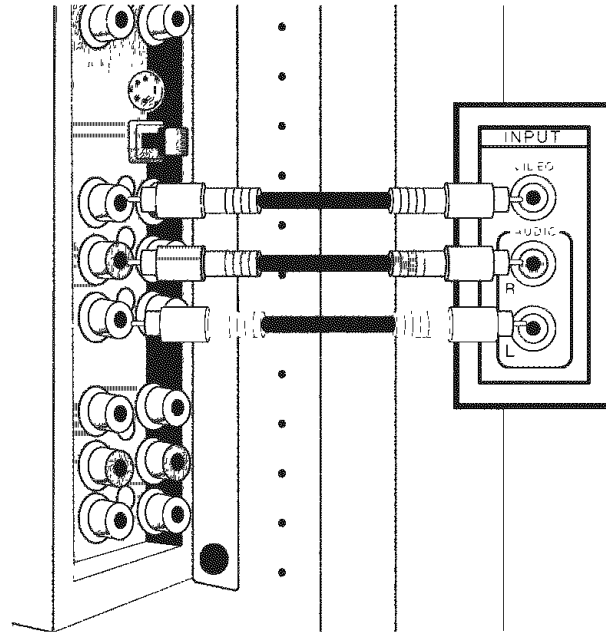

Connecting a PC

Your display can be used as a computer monitor for any computer with a VGA video output. In addition, the computer's audio output can be connected to the display and played through the display's speakers.

To connect a PC to the display:

1. Set the video resolution on the computer to 1280 × 1024 or less before connecting to the display (see "Supported VGA Modes" on page 29 for a full list of supported modes).

In Windows, right-click on the desktop and select **Properties** to bring up the Display Properties window. Select the **Settings** tab. Adjust the **Screen resolution** as needed, select **Apply**, then select **OK**.

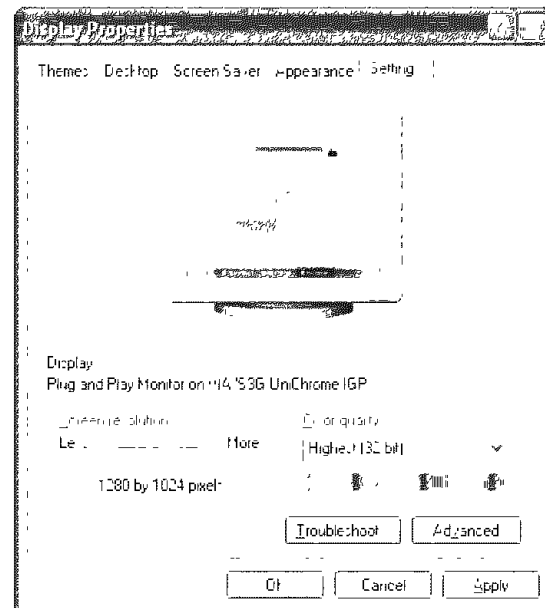

Setting Up the Display

In Mac OS X, select **System Preferences** under the Apple menu. Open the **Displays** panel and select the **Display** tab. Select the desired resolution from the list.

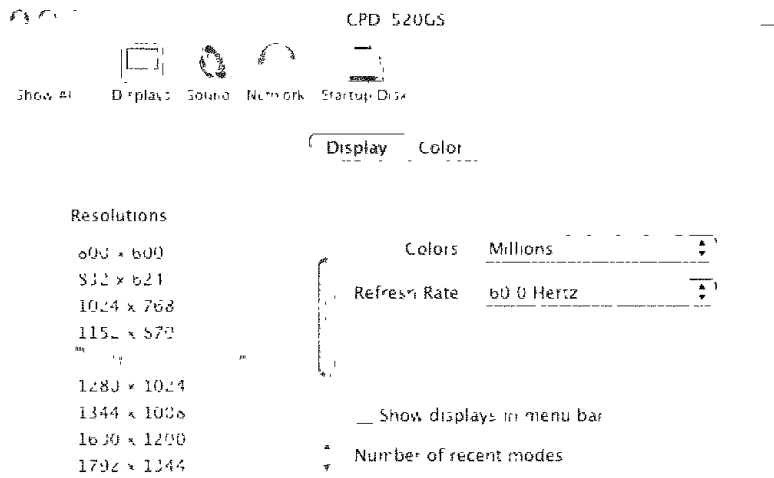

2. Connect a VGA cable between the VGA output on the computer and the VGA input on the display.

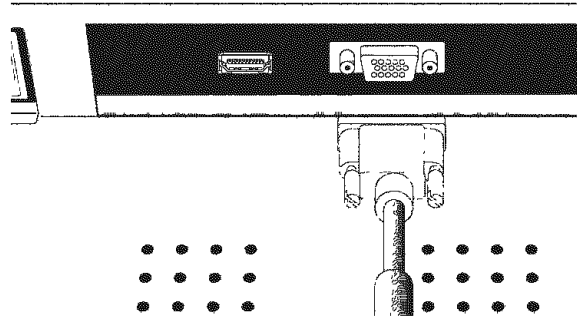

3. (OPTIONAL) Using a 1/8" stereo audio cable, connect the computer's audio output (LINE OUT) to the audio input on the bottom of the display (PC AUDIO IN).

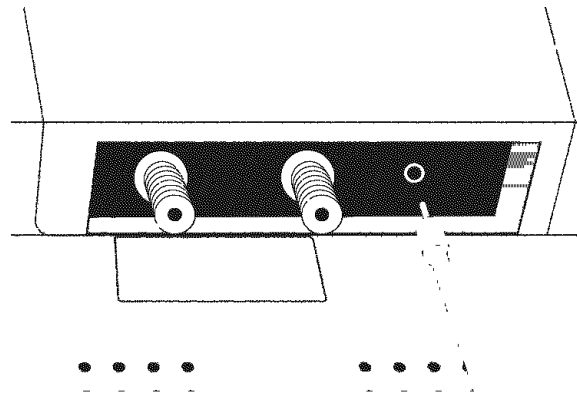

Operating the Display

Turning the Display On and Off

There is a power switch on the bottom of the display and a power button on the top of the display and on the remote. The power switch is used to cut off power completely, whereas the power button turns the screen off but allows the remote to continue working.

To turn the display on:

1. If the power light on the front of the display is off, turn on the power switch on the bottom of the display.
2. Press the **POWER** button.

To turn the display off:

1. Press the **POWER** button.
2. If the display will be unused for an extended period of time, turn off the power switch on the bottom of the display and disconnect the power.

Selecting the Video and Audio Source

The signal source may come from any of the input blocks on the sides or bottom of the display. The **SOURCE** button cycles through these.

To change the audio/video source, press the **SOURCE** button until the correct source is selected. The **SOURCE** button cycles through the following sources:

- TV
- AV1
- AV2
- AV3
- S-Video
- YPbPr1
- YPbPr2
- HDMI
- DTV
- VGA

Adjusting the Volume

The audio volume may be adjusted from the remote or the top of the display.

To change the volume, press the **VOL ◀** and **VOL ▶** buttons.

Selecting the Television Channel

The television channel may be selected from the remote or the top of the display.

To change the channel, press the **CH ▲** and **CH ▼** buttons.

To change to a particular channel directly, enter the desired channel number on the remote's keypad, then press **ENTER**.

Operating the Display

Accessing the On-Screen Display

The On-Screen Display allows you to configure the operation of the display. You can change video and audio settings, activate and configure closed captioning, select television channels, control access to mature programming, and configure other general display behavior. See "Configuring the Display" on page 16 for more information.

To access the OSD, press the **MENU** button.

Using Your Display for the First Time

When you turn on your LCD for the first time, you will need to set up the display for proper operation by scanning the television spectrum for available channels.

Setting up Digital Television Channels

Once the HDTV signal is connected to the display, you should scan all channels to find strong signals. This will make it much easier to navigate through the channels.

To scan all channels:

1. Turn the display on using the **POWER** button.
2. Press **SOURCE** until the signal source is set to DTV.
3. Press **MENU** to bring up the On-Screen Display (OSD).

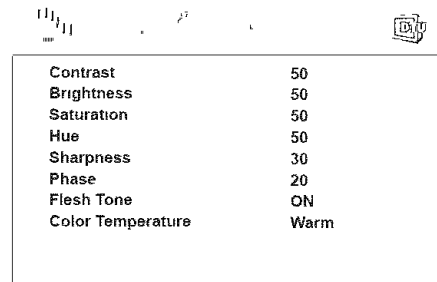

Contrast	50
Brightness	50
Saturation	50
Hue	50
Sharpness	30
Phase	20
Flesh Tone	ON
Color Temperature	Warm

Select **←/→** Exit **ESC**

4. Press the **▶** button until the DTV General menu shows.
5. Press **▼** until Time Zone is highlighted and then press **▶** until the correct time zone is selected.
6. Press **▼** until Auto Scan is highlighted and then press **ENTER** to begin scanning for available television channels.

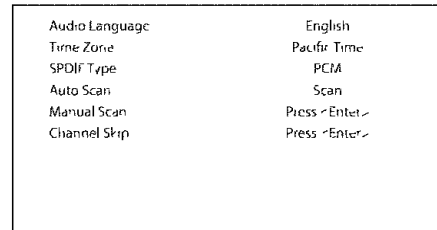

Audio Language	English
Time Zone	Pacific Time
SPDIF Type	PCM
Auto Scan	Scan
Manual Scan	Press <Enter>
Channel Skip	Press <Enter>

Select **←/→** Exit **MENU**

Setting up Analog Television Channels

Once an analog television signal is connected to the display, if you are connecting directly to a wall jack or antenna, you should scan the signal spectrum to weed out channels with insufficient signal strength. This will make it much easier to navigate through the channels.

To scan the signal spectrum:

1. Turn the display on using the **POWER** button.
2. Press **SOURCE** until the signal source is set to TV.
3. Press the **MENU** button to bring up the On-Screen Display (OSD).

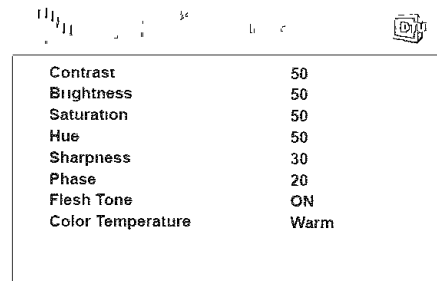

Contrast	50
Brightness	50
Saturation	50
Hue	50
Sharpness	30
Phase	20
Flesh Tone	ON
Color Temperature	Warm

Select **←/→** Exit **MENU**

Using Your Display for the First Time

4. Press the ► button until the TV menu shows.
5. Press the **ENTER** button to enter the menu.
6. Press ▼ until Tuner Mode is highlighted, then press **ENTER** again to select it.
7. Press the ▲ and ▼ buttons until the appropriate system is highlighted, then press the **ENTER** button to select it.

Select Air if you are using an antenna.

Select one of the Cable options if you are connecting directly to a cable TV wall outlet. Contact your cable service provider to find out which system is in use in your area. Cable or Cable IRC will work with most systems.

8. Press ◀ to return to the TV menu.
9. Press ▲ until Auto Search is highlighted and then press **ENTER** to select it.

The display will automatically scan all television channels for those with a strong signal. You can press **ENTER** at any time to stop the process.

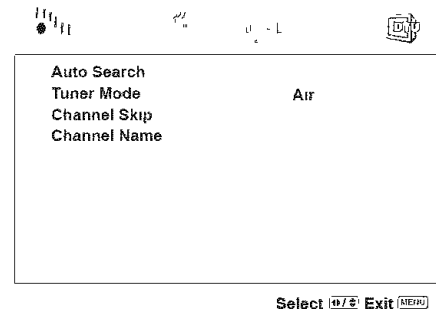

Using the Remote Control



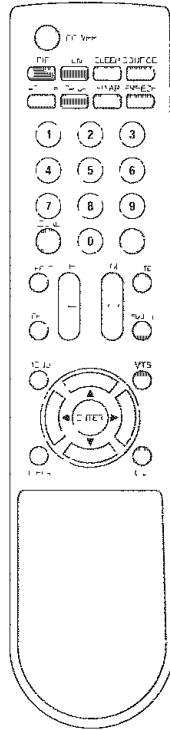



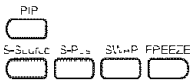
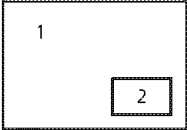
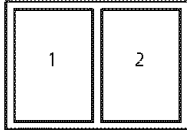





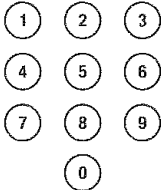

The remote control can be used to control every aspect of the display's operation and includes more functionality than the controls on the top of the display.

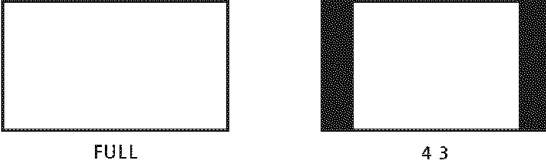

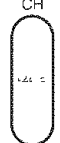

The following is a list of all buttons on the remote and their functions:

Button(s)	Function
	Turns the display on and off
	<p>These buttons activate and configure Picture-in-Picture (PIP), as follows:</p> <ul style="list-style-type: none"> • PIP—Selects the PIP mode: Off, Standard PIP, or PBP (Picture-by-Picture) <div style="display: flex; justify-content: space-around; align-items: center;"> <div style="text-align: center;">  <p>PIP</p> </div> <div style="text-align: center;">  <p>PBP</p> </div> </div> <ul style="list-style-type: none"> • S-SOURCE—Selects the signal source used for the secondary window. See "Picture-in-Picture Combinations" on page 29 for a list of possible signal source combinations for the main and secondary windows. • S-POS—When PIP is set to Standard PIP mode, adjusts the position of the secondary PIP window • SWAP—Swaps the primary and secondary sources • FREEZE—Freezes the content of the main window

Using the Remote Control

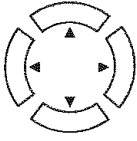
Button(s)	Function
	Brings up the V-Chip configuration menu
	Sets the display sleep timer. The timer can be turned off or set to 30, 60, 90, or 120 minutes.
	Selects the signal source (the signal source for the main window when PIP is enabled): TV, AV1, AV2, AV3, S-Video, YPbPr1, YPbPr2, HDMI, DTV, or VGA
	Used to enter numbers on the display and to select the television channel
	Returns to the previous channel
	When viewing HDTV, used to jump to a television channel once it has been entered on the keypad
	Selects the aspect ratio used by the display: 4:3 or Full (16:9)
	
	Mutes the audio
	When viewing HDTV, brings up the HDTV program guide, which displays program schedules and information for each channel
	Turns surround sound simulation on and off
	Selects the television channel
	Adjusts the audio volume
	Brings up the On-Screen Display
	Selects the MTS (Multichannel Television Sound) audio channel used for television: Mono, Stereo, or SAP (Secondary Audio Programming)
	Displays current source and television channel information

Button(s)	Function
	Cycles through the closed captioning modes: Off, C1-4, and T1-4
	Used to navigate display menus
	Selects the highlighted item or confirms the current adjustment

Note: To use a universal remote with your display, program the remote to control any NEC television.

Replacing the Remote Batteries

The remote requires two AAA batteries, which are held in a small enclosure on the rear of the remote.

To replace the batteries:

1. Release the tab and pull the enclosure out of the remote.
2. Remove the old batteries and replace them with the new batteries. Ensure the batteries are oriented as indicated in the enclosure.
3. Snap the enclosure back into the remote.

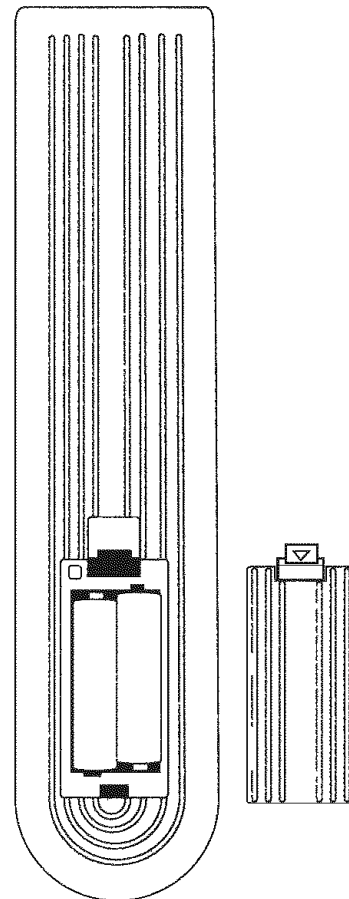

Configuring the Display

The On-Screen Display (OSD) allows you to configure the operation of the LCD. You can change video and audio settings, activate and configure Picture-in-Picture (PIP) and closed captioning, select television channels, control access to mature programming, and configure other general display behavior.

To use the OSD:

1. Press the **MENU** button on the remote or the top of the display.
2. Once the OSD appears, use the ◀ and ▶ buttons to navigate the menus represented by icons at the top of the OSD.
3. Press the **ENTER** button to enter the selected menu.
4. Use the ▲ and ▼ buttons to navigate the menu items.
5. Press the **ENTER** button to select the desired item.
6. If no text is displayed next to the item name, a sub-menu will appear upon pressing **ENTER**. Repeat steps 4 and 5 to navigate the sub-menu.

If the selected item is an adjustable parameter, one of two things will happen:

A pop-up box will appear, in which case use ◀ and ▶ to adjust the parameter and then press **ENTER** to accept the value.

The parameter will edit in place, in which case use ▲ and ▼ to adjust the value and then press **ENTER** to accept. Then press ◀ to return to the menu. While editing the parameter, a check mark will show next to the currently selected value.

7. Press ◀ to exit a menu.
8. Press **MENU** to exit the OSD.

Note: The currently selected source determines which menus are available in the OSD. The following table lists the menus available for each source:

Source	Menu					
	Video	Audio	Misc.	TV	PC	DTV
TV	•	•	•	•		
AV1	•	•	•			
AV2	•	•	•			
AV3	•	•	•			
S-Video	•	•	•			
YPbPr1	•	•	•			
YPbPr2	•	•	•			
HDMI		•	•		•	
DTV		•	•		•	•
VGA		•	•		•	

Configuring the Display

Video

The Video menu allows you to change the display's video settings. You can adjust the following parameters:

Contrast

Sets the variation between light and dark colors

Brightness

Sets the brightness of the display image

Saturation

Sets the saturation of color in the display image

Hue

Sets the intensity of color in the display image

Sharpness

Sets the image sharpness

Phase

(YPbPr1 and YPbPr2 only)

Adjusts the phase of the video synchronization

Flesh Tone

Turns on and off image filtering to improve flesh tones in the image

Color Temperature

Sets the color temperature used by the display: Cool, Normal, Warm, or a user-defined setting.

To set the user-defined color temperature, select the User option and adjust the levels of red, green, and blue to be used to produce white. Use ▲ and ▼ to select a color, then use ◀ and ▶ to adjust the level.

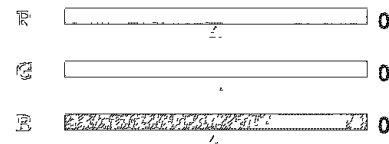
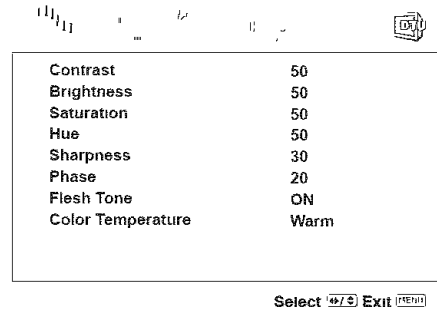

Audio

The Audio menu allows you to change the way audio is played, including balance, equalization, and other sound processing. You can change the following settings:

Bass

Adjusts the volume of bass in the audio

Treble

Adjusts the volume of treble in the audio

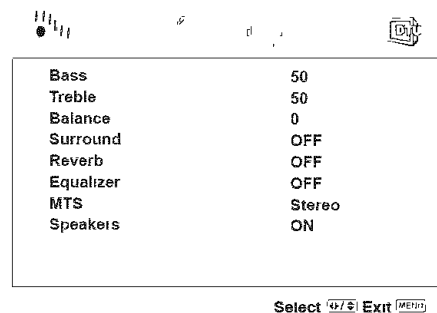

Configuring the Display

Balance

Sets the relative volumes of the left and right speakers

Surround

Turns surround sound simulation on and off

Reverb

Selects the preset used for reverb simulation, which is designed to simulate room environments: Church, Arena, Cave, Bathroom, Hall, Living Room, Concert, or Off (no reverb)

Equalizer

Selects the preset used for the equalizer, which is designed to enhance the type of audio being played: Soft, Classic, Techno, Dance, Live, Pop, Rock, or Off (no equalization)

MTS

(TV only)

Selects the MTS (Multichannel Television Sound) channel played back while watching television: Mono, Stereo, or SAP (Secondary Audio Programming)

Speakers

Turns the built-in speakers on and off

Miscellaneous

The Miscellaneous menu contains general display settings, including OSD options, timers, display format, closed captioning, Picture-in-Picture, and parental controls. It contains the following menu items:

Language

Selects the language used for the OSD: English, French, or Spanish

Timer

A sub-menu that allows you to schedule the display to turn on or off at a particular time, and switch to a particular channel:

- **Time**—The current time. To adjust, select each digit using ◀ and ▶ and enter the desired value on the keypad.
- **Turn On**—The time at which the timer will turn the display on
- **Turn Off**—The time at which the timer will turn the display off
- **Channel**—The TV channel the timer switches to when it turns the display on
- **Activate**—Activates and deactivates the timer. The options are On, Off, and Once (the timer will go off once and then deactivate).
- **Display**—Tells the timer to ask the user (by displaying a dialog box) before turning the display off

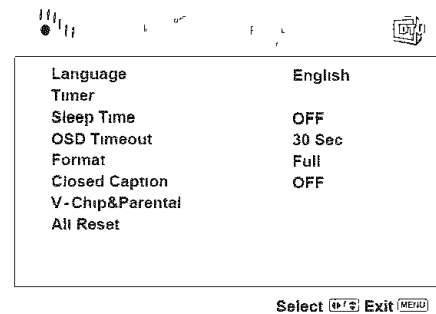

Sleep Time

Activates and sets a sleep timer that automatically puts the display into standby mode when there is no activity for a specified period. The timer may be turned off or set to 30, 60, 90, or 120 minutes.

OSD Timeout

Sets the inactivity timeout for the OSD: 10, 20, or 30 seconds

Format

Controls the aspect ratio used by the display: 4:3 or Full (16:9—widescreen).

Note: You cannot change the aspect ratio when PIP is active.

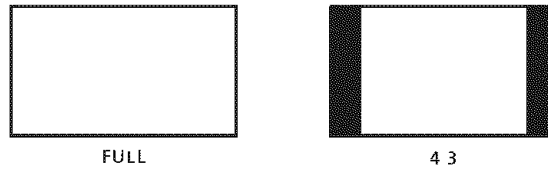

Closed Caption

Turns closed captioning on and off and selects the closed captioning channel used. Closed captioning displays the dialog of the current program or other information on the screen so it may be read.

The available channels are C1–4 and T1–4. C1 is the most-used closed captioning channel, usually used for English dialog. C2 is usually used for foreign language translations. T1–4 are usually used for other channel information.

The C1–4 modes display only a few lines of text at the bottom of the screen. The T1–4 modes scroll text across most of the screen.

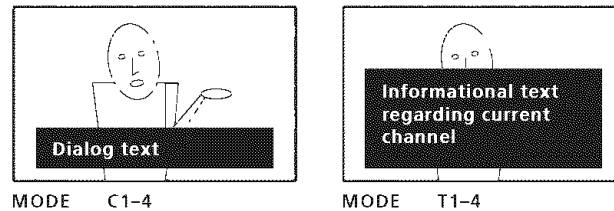

Configuring the Display

V-Chip & Parental

This sub-menu allows you to control access to television content based on industry maturity ratings.

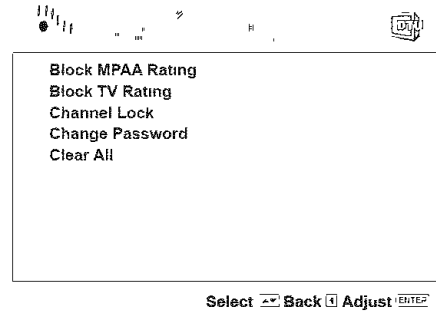

Upon attempting to enter the sub-menu, the display will ask for the current password. Once you enter the password, the sub-menu will display.

The factory-default password is '1234'.

The following menu items are available:

- **Block MPA Rating**—A sub-menu that sets the MPA (Motion Picture Association of America) rating level the V-Chip will block without a password.

Blocking a particular rating will automatically block all ratings above that level. Similarly, unblocking a rating will automatically unblock all ratings below that level.

Select a rating using the arrow controls on the remote, then press **ENTER** to block/unblock it. Press **MENU** to exit this sub-menu.

The ratings are as follows:

	x
	x
	x
	x
	x
	x
✓	x

Rating Level	Significance
G	General audiences (all ages)
PG	Parental guidance suggested (some material may not be suitable for children)
PG-13	Parents strongly cautioned (some material may be inappropriate for children under 13)
R	Restricted (minors under 17 require an accompanying parent or adult guardian)
NC-17	No one under 17 admitted
X	Adults only (no one under 17 admitted)

Configuring the Display

- **Block TV Rating**—A sub-menu that sets the TV PG rating level (listed on the left) the V-Chip will block without a password.

Specific types of mature content (listed across the top) can be blocked for some of the ratings. For example, programs rated TV-Y7 with violent content can be blocked.

Blocking a particular rating will automatically block all ratings above that level. Similarly, unblocking a rating will automatically unblock all ratings below that level.

Select a rating using the arrow controls on the remote, then press **ENTER** to block/unblock it. Press **MENU** to exit this sub-menu.

The ratings are as follows:

Rating Level	Significance
TV-Y	All children
TV-Y7	Children 7 years and older
TV-G	General audience
TV-PG	Parental guidance suggested
TV-14	Parents strongly cautioned
TV-MA	Mature audience only

Content Type	Significance
FV	Fantasy violence
V	Violence
S	Sexual content
L	Foul language
D	Suggestive dialog

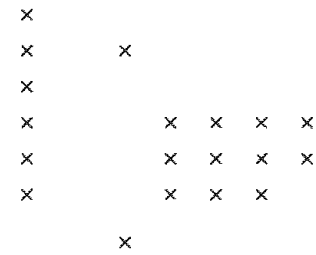

- **Channel Lock**—Allows you to block individual channels. When you select a channel to be blocked, a lock icon will appear next to it.
- **Change Password**—Sets the V-Chip password. To change the password, enter the current password, then enter and confirm the new password.
The factory-default password is '1234'.
- **Clear All**—Resets all V-Chip settings to factory defaults (unblocked)

All Reset

Resets all display options to factory-default settings

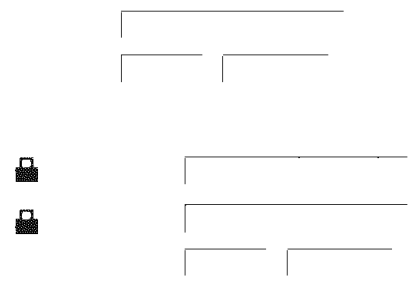

Configuring the Display

TV

The TV menu allows you to select the television signal type, select which television channels are available for viewing, manually or automatically, and give a name to each channel. It contains the following menu items:

Auto Search

When selected, automatically scans all television channels for valid signals and makes unavailable any channels with insufficient signal strength

Tuner Mode

A sub-menu that sets the type of television signal source in use. The options are as follows:

- **Air**—A standard television antenna
- **Cable**—A cable TV signal
- **Cable-IRC**—A type of cable signal primarily used on the East Coast of the US
- **Cable-HRC**—A type of cable signal primarily used on the West Coast of the US

Channel Skip

Allows you to manually adjust which channels are available when flipping through channels. A check mark next to a channel number indicates that the channel is available.

Channel Name

A sub-menu that allows you to assign a name to the current channel. Enter characters by selecting them with the arrow controls on the remote and then pressing **ENTER**. Select **Backspace** to delete characters. Select **OK** when finished or **Cancel** to abort.

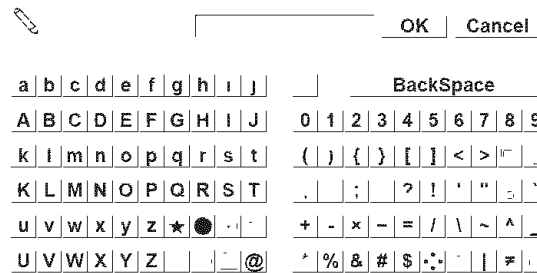
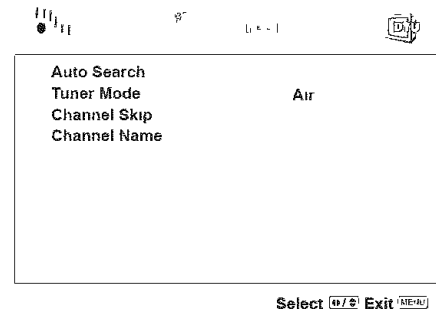

PC

The PC menu allows you to change the video options used with a VGA or HDMI video source. You can adjust the following parameters:

Contrast

Sets the variation between light and dark colors

Brightness

Sets the brightness of the display image

Color Temperature

(VGA only)

Sets the color temperature used by the display: Cool, Normal, Warm, or User (a user-defined setting).

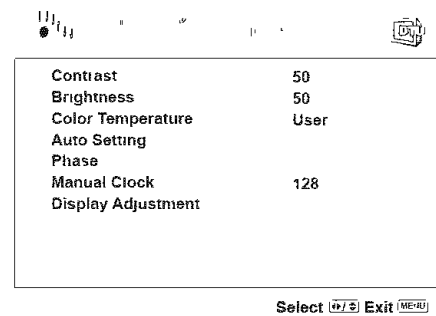

Configuring the Display

To set the user-defined color temperature, select the User option and adjust the levels of red, green, and blue to be used to produce white. Use ▲ and ▼ to select a color, then use ◀ and ▶ to adjust the level.

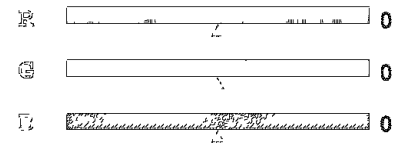

Auto Setting

(VGA only)

When turned on, automatically adjusts the image position

Phase

(VGA only)

Adjusts the phase of the video clock

Manual Clock

(VGA only)

Adjusts the frequency of the video clock

Display Adjustment

A sub-menu that controls the position of the image on the screen. The two parameters are Horizontal Position and Vertical Position.

DTV

The DTV menu is a separate menu system for HDTV configuration that allows you to configure the available channels, closed captioning, parental controls, and other HDTV options.

Note: The navigation procedure for the DTV menu differs from that of the main OSD, as follows.

To use the DTV menu:

1. Use the ◀ and ▶ buttons to navigate the sub-menus represented by icons at the top of the menu.
2. Press the ▼ button to enter the selected menu.
3. Use the ▲ and ▼ buttons to navigate the menu items.
4. If "Press <Enter>" appears to the right of the selected item, a dialog box will appear upon pressing **ENTER**. Repeat steps 3 and 4 to navigate the dialog box.

If the selected item is an adjustable parameter, use the ◀ and ▶ buttons to adjust the value.

5. Press ▲ repeatedly to exit a sub-menu.
6. Press **MENU** to exit the OSD.

Configuring the Display

The DTV menu contains the following sub-menus:

General

Sets general HDTV options and allows you to scan for available HDTV channels and enable and disable channels. The options are as follows:

- **Audio Language**—Sets the broadcast audio language used: English, French, or Spanish
- **Time Zone**—Sets the current time zone
- **SPDIF Type**—Selects the type of S/PDIF audio put out on the optical S/PDIF output: Dolby Digital, PCM, or Off
- **Auto Scan**—Automatically scans all channels for strong signals and disables any channels with weak signals
- **Manual Scan**—Brings up a dialog box that allows you to manually scan channels.

Set the **Scan Mode** to "Add-on Mode" to scan all channels that have not yet been scanned.

To scan a particular range of channels, set the **Scan Mode** to "Range Scan," then enter the start and end channels on the remote keypad.

Once the **Scan Mode** has been set, press **ENTER** to begin the scan.

- **Channel Skip**—Brings up a dialog box allowing you to disable individual channels. To enable/disable a channel, select it using the arrow buttons on the remote, then press **ENTER** to toggle. A check mark to the right of a channel means the channel is disabled.

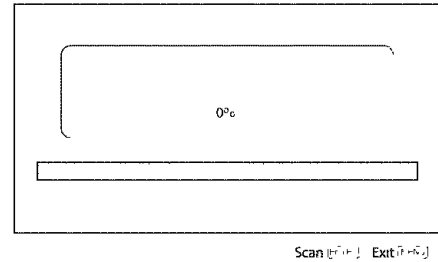
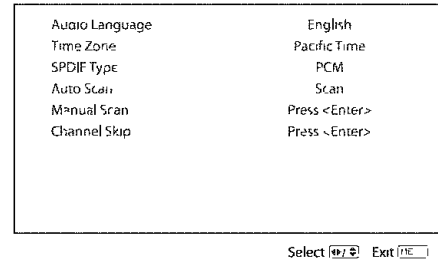

Caption

Configures HDTV closed captioning. The options are as follows:

- **Analog Closed Caption**—Selects the analog caption channel to be displayed on-screen. You can select CC1–4 or turn analog closed captioning off.
- **Digital Closed Caption**—Selects the digital caption channel to be displayed on screen. You can select Service1–6 or turn digital closed captioning off.

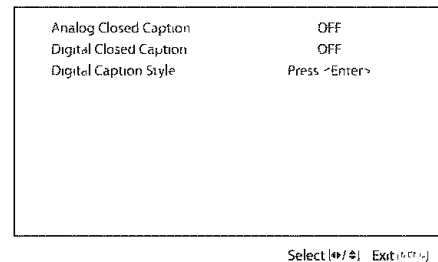

Configuring the Display

- Digital Caption Style**—Brings up a dialog box that allows you to set how the digital caption will be displayed on-screen. You can set the font size, color, and opacity; background color and opacity; and window color and opacity. A sample of how the current settings will look displays to the right of the menu.

Caption Style	Custom
Font Size	Large
Font Color	Black
Font Opacity	Solid
Background Color	White
Background Opacity	Solid
Window Color	White
Window Opacity	Translucent

Select [F7] Exit [F4]

A B C

Parental

Configures parental controls for HDTV programming, allowing you to block individual channels.

To access the menu, select **Password** and enter the current password, which is set in the main parental controls menu (see "V-Chip & Parental" on page 20).

To block/unblock channels, select **Channel Block** and press **ENTER** to bring up the Channel Block dialog box. Select the desired channel using the arrow buttons on the remote, then press **ENTER** to toggle. A check mark to the right of a channel means the channel is blocked.

Channel Block	Press <Enter>
---------------	---------------

Select [F7] Exit [F4]

Troubleshooting

Symptom	Possible Cause	Resolution
No picture (power indicator does not light up)	Power cord not securely connected	Make sure the power cord is firmly inserted into the socket and outlet.
	Power switch is off	Turn on the power switch on the bottom of the display.
	Power outlet is off or not working	Try plugging a different device into the outlet and see if it turns on. If not, turn on the outlet or use a different outlet.
No picture (power indicator is red)	The display is in power-saving mode	If connected to a computer and in VGA or HDMI mode, press a key on the keyboard or move the mouse. Otherwise, press a button on the remote.
	The display is off	Press the POWER button on the remote or on the top of the display.
No picture (power indicator is green)	No signal	Make sure the proper source is selected. If there is still no picture, check the signal cable(s) and signal source.
	Contrast or brightness too low	Adjust the contrast and/or brightness until picture appears.
Unclear or noisy picture	Signal cable(s) not securely connected	Make sure the signal cable(s) are firmly connected.
	Poor TV signal	Check the TV signal. If using an antenna, adjust the position for better signal. If using cable or satellite TV, contact your service provider.
No sound	Audio cable(s) not securely connected	Make sure the audio signal cable(s) are firmly connected.
	Headphones plugged in	Unplug the headphones.
	Audio muted	Unmute the audio by pressing the MUTE button on the remote.
Display is too dark or too bright	Contrast or brightness too low or too high	Adjust the contrast and/or brightness to desired setting.
Display not centered	Position incorrectly adjusted in OSD	Adjust the image position in the PC menu in the OSD (see "PC" on page 22).
Image vibrating	Signal cable(s) not securely connected	Make sure the signal cable(s) are firmly connected.
	Power voltage too high or too low	Check the power source to make sure it matches the display specification. Try a different power outlet on a different circuit.

Symptom	Possible Cause	Resolution
After-image remains on screen after display is turned off	Inherent LCD characteristics	This is characteristic of an LCD. The after-image will disappear after a few minutes.
Distorted image	Display format set incorrectly	Check that the correct Format is selected in the Miscellaneous menu in the OSD (see "Miscellaneous" on page 18).
"Out of Range" message on screen	VGA input signal is not in a supported mode	Adjust the resolution and refresh rate on the PC to match a supported mode, listed under "Specifications" on page 28.
Red, green, blue, or white dots on screen	Inherent LCD characteristics	This is characteristic of an LCD and will not cause a malfunction.
Remote control not functioning	Batteries inserted improperly	Make sure the batteries are inserted and oriented properly.
	Batteries low on energy	Replace the batteries.
	A button is stuck	Jog any stuck buttons on the remote to unstick them.
	Obstacle between remote and display	Remove the obstacle.
	The remote is too far from the display	Move closer to the display.

If none of the resolutions above resolves the problem, turn the display off and then on again using the power switch on the bottom of the display, then check to see if the problem has resolved.

Note: Further troubleshooting information can be found on the Protron website at www.protronusa.com.

Support Information



Do not return this product to your retailer until you have performed the steps laid out in the Easy Setup Instructions and contacted the Customer Service Center. Merchandise may not be returned to Protron without a return form authorization.

Before contacting Protron Customer Service, please record the following information, which may be found on the back of your display:

- Model Number
- Serial Number
- Date of Manufacture

The Protron Customer Service Center may be contacted 24 hours a day, 7 days a week at the following number:

1-888-257-8899

Specifications

General

Dimensions	37.4" (950mm) W × 29.7" (755mm) H × 10.0" (255mm) D
Weight	82.2lbs (37.3kg)
Panel Type	Active Matrix TFT LCD
Screen Size	37" widescreen (16:9)
Color Range	24 bits (16.7 million colors)
Max. Resolution	1366 × 768
Pixel Pitch	0.60mm (H) × 0.60mm (V)
Sync Range	Horizontal: 30–80kHz Vertical: 50–75Hz
Contrast Ratio	1200:1
Brightness	500 cd/m ²
Viewing Angle	+/-89° (H/V)
Response Time	8ms
Inputs	1 × ATSC TV (75 ohm coaxial F) 1 × NTSC-M TV (75 ohm coaxial F) 1 × HDMI 2 × progressive scan component video (RCA) 3 × composite video (RCA) 1 × S-Video 6 × stereo audio (RCA) 1 × SVGA (15-pin D-Sub) 1 × stereo audio line in, 0 dBV nominal (1/8" TRS)
Outputs	1 × composite video (RCA) 1 × optical S/PDIF audio (TOSLINK™) 1 × stereo audio (RCA) 1 × subwoofer (RCA) 1 × headphone (1/8" TRS)
Video Formats Supported	SDTV: 480i EDTV: 480p HDTV: 720p, 1080i
TV Tuners	NTSC-M, CATV, 125 channels ATSC HDTV
TV Audio	NTSC: Mono, Stereo, SAP ATSC: Stereo, Dolby Digital 5.1 Surround
Parental Controls	V-Chip (TV PG, MPAA)
Picture-In-Picture	PIP, PBP
Closed Captioning	NTSC: CC1–4, TEXT1–4 ATSC: Analog channels 1–4, digital channels 1–6
Speakers	2 × 10W
Plug and Play Compliance	VESA DDC1, DDC2B

Power Supply	100–240VAC, 50–60Hz
Power Consumption	Operation: 288W typical Standby: <3W
Storage Temperature	0 to 60°C
Operating Temperature	5 to 35°C

Picture-in-Picture Combinations

Secondary Source	Primary Source									
	TV	AV1	AV2	AV3	S-Video	YPbPr1	YPbPr2	HDMI	DTV	VGA
TV		•	•	•	•	•	•	•	•	•
AV1	•		•	•	•	•	•	•	•	•
AV2	•	•		•	•	•	•	•	•	•
AV3	•	•	•		•	•	•	•	•	•
S-Video	•	•	•	•				•	•	
YPbPr1	•	•	•	•				•	•	
YPbPr2	•	•	•	•				•	•	
HDMI	•	•	•	•	•	•	•			
DTV	•	•	•	•	•	•	•			
VGA	•	•	•	•						

Supported VGA Modes

Display Resolution	Vertical Frequency (Refresh Rate) Hz	Horizontal Frequency kHz	VESA Standard
640 × 480	60	31.5	•
	72	37.9	•
	75	37.5	•
	85	43.3	•
800 × 600	56	35.1	•
	60	37.9	•
	72	48.1	•
	75	46.9	•
	85	53.7	•
1024 × 768	60	48.4	•
	70	56.5	•
	75	60.0	•
	85	68.7	•
1280 × 720	60	47.7	
1280 × 768	60	44.8	
1280 × 1024	60	64.0	•
1366 × 768	60	47.7	



Limited Warranty

Protron warrants this product to be free from manufacturing defects in material and workmanship under normal use for the term stated below.

How to obtain service:

- Visit the Protron Customer Service Portal at www.protronusa.com support tab or call Protron Customer Support at 1-888-257-8899. If the issue cannot be resolved over the phone with trouble-shooting techniques, you may be eligible for warranty service. To request warranty repair, you may also contact us by e-mail at protron@ewestcsp.com. All warranties must be authorized by Protron prior to service and will result in the issuance of an authorization number for service.
- For televisions with screen sizes of 37" or less, you will be requested to ship your television to our National Return Center.
- For televisions with screen sizes 40" and above, you may be eligible for in-home service. Our Customer Service Representative will locate an authorized Protron Service Center, provided that your television is located within the geographic territory covered by an authorized Protron Service Center. If in-home service is not available in your area, you must either take your television to the Service Center location at your own expense, pay for the additional cost that the Service Center may charge to transport your television to and from your home, or send the unit to our National Return Center for repair.
- Proof of purchase in the form of a bill of sale or receipted invoice with product name, model and/or serial number, which provides evidence that the product is within the warranty period, must be presented to obtain warranty service.

This warranty does not cover:

- Physical or cosmetic damages
- Damage caused by abuse and/or neglect
- Ordinary adjustments as outlined in the owners manual that can be performed by the customer
- Damage to equipment not properly connected to the product
- Any cost incurred in shipping the product for repair
- Signal reception problems caused by external antenna, cable systems or interference
- Incompatibility due to a change in TV/CATV broadcast systems after the product was sold
- Batteries
- Images burnt on to the screen
- Initial installation and related adjustments
- Power surge and/or damage by lightning
- Force majeure or uncontrollable external force damage
- Product shipped for service with inadequate packaging or packaging materials

*Limited Warranty****What we will do:***

- Protron will repair and/or replace your product at our National Return Center with new, like new, or refurbished product and/or parts, at our discretion.
- For models 40" and above, Protron will reimburse an authorized Protron Service Center, obtained by Protron for you, for the new or, at our discretion, refurbished replacement parts required to repair your television.

This warranty is void if:

- Product is used in a commercial application or rental.
- Damaged through misuse, negligence or abuse.
- Modified or repaired by anyone other than authorized Protron Service Center.
- Damaged because it is improperly connected to any other equipment.
- If the original proof of purchase cannot be supplied.
- If the identifiable markings on the TV such as the serial number are defaced, unrecognizable, or missing.
- The product is used outside the country in which it was originally sold.

This warranty is not transferable and only applies to the original purchase. Any implied warranties, including the warranty of merchantability, are limited in duration to the period of this expressed warranty and no warranty whether expressed or implied shall apply to the product thereafter. Under no circumstance shall Protron be liable for any loss or consequential damage arising out of the use of this product. This warranty gives specific legal right. However, you may have other rights that may vary from state/province to state/province. Some states/provinces do not allow limitations on implied warranties or exclusions of consequential damage. Therefore these restrictions may not apply to you.

37" and Below: 1 year Parts & Labor Depot Warranty

40" and Above: 1 year Parts & Labor In-Home Warranty

Protron Digital Corporation

<http://www.protronusa.com/>

PLTV-3750

OMPLTV3750