

Palmcorder®
PalmSight™



Panasonic®

Camcorder
Operating Instructions

Model No. **PV-L750**

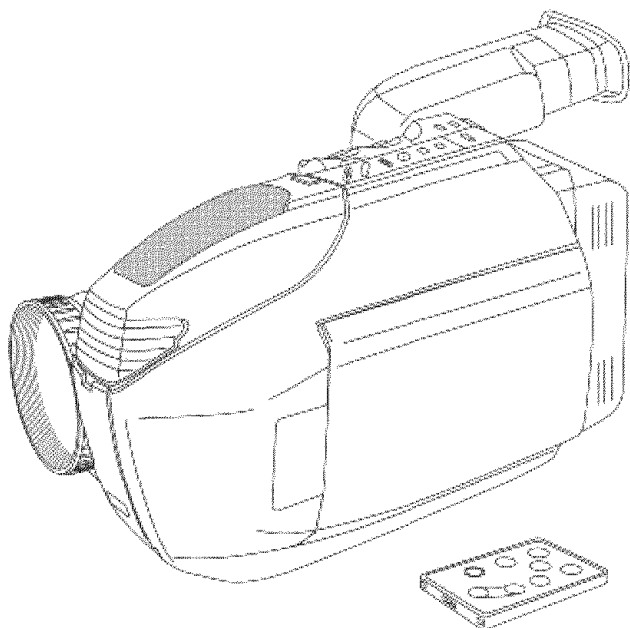

Please read these instructions carefully before attempting to operate this product.
Please save this manual.

Guía para rápida consulta en español está incluida.

For assistance, call 1-800-211-PANA(7262)

LSQT0203A

Getting Started

Basic Operation

Special Features

For Your Information

Things You Should Know

Thank you for choosing Panasonic!

You have purchased one of the most sophisticated and reliable products on the market today. Used properly, it will bring you years of enjoyment. Please take time to fill in the information at the right. The serial number is on the tag located on the rearside of your Camcorder. Be sure to **retain this manual** as your convenient Camcorder information source.

Date of Purchase _____

Dealer Purchased From _____

Dealer Address _____

Dealer Phone No. _____

Model No. _____

Serial No. _____

Unpack your Camcorder

These accessories are provided in order to set up or use your Camcorder.

1 pc. AC Adaptor (PV-A17)
with DC Power Cable
(page 14)



1 pc. Battery Pack (PV-BP18)
(pages 12, 13)



1 pc. Audio/Video Cable
(LSJA0283/VJAW0032/
VJAW0039) (pages 31, 33)



1 pc. VHS PlayPak
(PV-P1/VYMW0009) and
one "AA" battery (page 32)

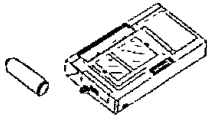

1 pc. Shoulder Strap
(VYCW0225) (page 16)



1 pc. CR2025 Clock Battery
(VSBW0004)
(installed in Camcorder)
(page 74)



1 pc. Digital PhotoShot Disk
for Windows 95/98
(LSFT0193) (page 61)



1 pc. CompactFlash Card
(8MB) (LSFA0009B)
(page 49)



1 pc. PC Connection cable
(RS232C-2.5P)
(LSJA0276) (page 60)

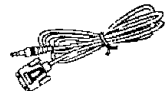

1 pc. Remote Control Holder
(VGQ6893) (pages 16, 28)



1 pc. 8-Function Remote
(VSQW0038) with one
CR2025 Battery. (page 28)

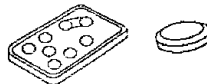

Remote has been loaded with
battery. (page 74)

CompactFlash Card is a trademark of SanDisk Corporation.

Microsoft and Windows are registered trademarks of Microsoft in the United States and other countries.

All product/brand names are trademarks or registered trademarks of the respective holders.

Things You Should Know





Safety Precautions

WARNING: TO PREVENT FIRE OR SHOCK HAZARD, DO NOT EXPOSE THIS EQUIPMENT TO RAIN OR MOISTURE.

Your Compact VHS Camcorder is designed to record and play back in Standard Play (SP) and Super Long Play (SLP) modes. You can also play a Compact VHS Camcorder recording on your VHS VCR using the VHS PlayPak supplied.

This Camcorder is equipped with the **HQ** System to provide excellent video pictures, and is compatible with standard VHS equipment.

It is recommended that only cassette tapes that have been tested and inspected for use in VCR machines with the **VHS** and/or **VHS** mark be used.

	CAUTION RISK OF ELECTRIC SHOCK DO NOT OPEN			This symbol warns the user that uninsulated voltage within the unit may have sufficient magnitude to cause electric shock. Therefore, it is dangerous to make any kind of contact with any inside part of this unit.
CAUTION: TO REDUCE THE RISK OF ELECTRIC SHOCK, DO NOT REMOVE COVER (OR BACK) NO USER-SERVICEABLE PARTS INSIDE REFER SERVICING TO QUALIFIED SERVICE PERSONNEL				This symbol alerts the user that important literature concerning the operation and maintenance of this unit has been included. Therefore, it should be read carefully in order to avoid any problems.

The above markings are located on the appliance bottom cover.

FCC Warning: To assure continued FCC compliance, the user must use only provided shielded interfacing cable when connecting to computer. Also, any unauthorized changes or modifications to this equipment would void the users authority to operate.

This device complies with Part 15 of the FCC Rules. Operation is subject to the following two conditions: (1) This device may not cause harmful interference, and (2) this device must accept any interference received, including interference that may cause undesired operation.

Note: This equipment has been tested and found to comply with the limits for a Class B digital device and a RF Lighting device, pursuant to part 15 and Part 18 of the FCC Rules.

These limits are designed to provide reasonable protection against harmful interference in a residential installation. This equipment generates, uses and can radiate radio frequency energy and, if not installed and used in accordance with the instructions, may cause harmful interference to radio communications. However, there is no guarantee that interference will not occur in a particular installation. If this equipment does cause harmful interference to radio or television reception, which can be determined by turning the equipment off and on, the user is encouraged to try to correct the interference by one or more of the following measures:

- Reorient or relocate the receiving antenna.
- Increase the separation between the equipment and receiver.
- Connect the equipment into an outlet on a circuit different from that to which the receiver is connected.
- Consult the dealer or an experienced radio/TV technician for help.

Important Safeguards

1. **Read Instructions** — All the safety and operating instructions should be read before the unit is operated.
2. **Retain Instructions** — The safety and operating instructions should be retained for future reference.
3. **Heed Warnings** — All warnings on the unit and in the operating instructions should be adhered to.
4. **Follow Instructions** — All operating and maintenance instructions should be followed.
5. **Cleaning** — Unplug this video unit from the wall outlet before cleaning. Do not use liquid or aerosol cleaners. Use a dry cloth for cleaning.
6. **Attachments** — Do not use attachments not recommended by the video product manufacturer as they may be hazardous.
7. **Water and Moisture** — Do not use this video unit near water — for example near a bath tub, wash bowl, kitchen sink, or laundry tub, in a wet basement, or near a swimming pool, and the like.
8. **Accessories** — Do not place this video unit on an unstable cart, stand, tripod, bracket, or table. The video unit may fall, causing serious injury to a child or adult, and serious damage to the unit. Use only with a cart, stand, tripod, bracket, or table recommended by the manufacturer, or sold with the video unit. Any mounting of the unit should follow the manufacturer's instructions and should use a mounting accessory recommended by the manufacturer. An appliance and cart combination should be moved with care. Quick stops, excessive force, and uneven surfaces may cause the appliance and cart combination to overturn.
9. **Ventilation** — Slots and openings in the cabinet are provided for ventilation and to ensure reliable operation of the video unit and to protect it from overheating. These openings must not be blocked or covered. Never place the video unit on a bed, sofa, rug, or other similar surface, or near or over a radiator or heat register. This video unit should not be placed in a built-in installation such as a bookcase or rack unless proper ventilation is provided or the manufacturer's instructions have been adhered to.
10. **Power Sources** — This video unit should be operated only from the type of power source indicated on the marking label. If you are not sure of the type of power supply to your home, consult your appliance dealer or local power company. For video units intended to be operated from battery power, or other sources, refer to the operating instructions.
11. **Grounding or Polarization** — This video unit may be equipped with either a polarized 2-wire AC (Alternating Current) line plug (a plug having one blade wider than the other) or 3-wire grounding type plug, a plug having a third (grounding) pin. The 2-wire polarized plug will fit into the power outlet only one way. This is a safety feature. If you are unable to insert the plug fully into the outlet, try reversing the plug. If the plug still fails to fit, contact your electrician to replace your obsolete outlet. Do not defeat the safety purpose of the polarized plug. The 3-wire grounding type plug will fit into a grounding type power outlet. This is a safety feature. If you are unable to insert the plug into the outlet, contact your electrician to replace your obsolete outlet. Do not defeat the safety purpose of the grounding type plug.
12. **Power-Cord Protection** — Power-supply cords should be routed so that they are not likely to be walked on or pinched by items placed upon or against them. Paying particular attention to cords of plugs, convenience receptacles, and the point where they exit from the unit.
13. **Outdoor Antenna Grounding** — If an outside antenna or cable system is connected to the video unit, be sure the antenna or cable system is grounded so as to provide some protection against voltage surges and built-up static charges. Part 1 of the Canadian Electrical Code, in USA Section 810 of the National Electrical Code, provides information with respect to proper grounding of the mast and supporting structure, grounding of the lead-in wire to an antenna discharge unit, size of grounding conductors, location of antenna discharge unit, connection to grounding electrodes, and requirements for the grounding electrode.
14. **Lightning** — For added protection of this video unit receiver during a lightning storm, or when it is left unattended and unused for long periods of time, unplug it from the wall outlet and disconnect the antenna or cable system. This will prevent damage to the video unit due to lightning and power-line surges.

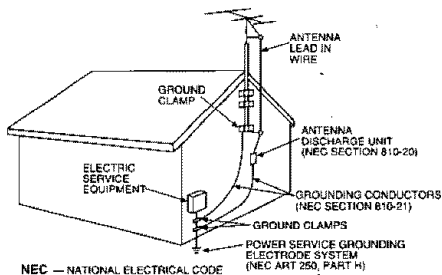

Important Safeguards

15. **Power Lines** — An outside antenna system should not be located in the vicinity of overhead power lines or other electric light or power circuits, or where it can fall into such power lines or circuits. When installing an outside antenna system, extreme care should be taken to keep from touching such power lines or circuits as contact with them might be fatal.
16. **Overloading** — Do not overload wall outlets and extension cords as this can result in a risk of fire or electric shock.
17. **Objects and Liquids** — Never push objects of any kind into this video unit through openings as they may touch dangerous voltage points or short out parts that could result in a fire or electric shock. Never spill liquid of any kind onto the video unit.
18. **Servicing** — Do not attempt to service this video unit yourself as opening or removing covers may expose you to dangerous voltage or other hazards. Refer all servicing to qualified service personnel.
19. **Damage Requiring Service** — Unplug this video unit from the wall outlet and refer servicing to qualified service personnel under the following conditions:
 - a. When the power-supply cord or plug is damaged.
 - b. If any liquid has been spilled onto, or objects have fallen into the video unit.
 - c. If the video unit has been exposed to rain or water.
 - d. If the video unit does not operate normally by following the operating instructions. Adjust only those controls that are covered by the operating instructions, as an improper adjustment of other controls may result in damage and will often require extensive work by a qualified technician to restore the video unit to its normal operation.
 - e. If the video unit has been dropped or the cabinet has been damaged.
 - f. When the video unit exhibits a distinct change in performance — this indicates a need for service.
20. **Replacement Parts** — When replacement parts are required, be sure the service technician has used replacement parts specified by the manufacturer or have the same characteristics as the original part. Unauthorized substitutions may result in fire, electric shock or other hazards.
21. **Safety Check** — Upon completion of any service or repairs to this video unit, ask the service technician to perform safety checks to determine that the video unit is in safe operating order.

Precautions

USE & LOCATION

- **TO AVOID SHOCK HAZARD ...** Your Camcorder and power supply should not be exposed to rain or moisture. Do not connect the power supply or operate your Camcorder if it gets wet. Your Camcorder has been designed for outdoor use, however it is not designed to sustain direct exposure to water, rain, sleet, snow, sand, dust, or a direct splashing from a pool or even a cup of coffee. This action could permanently damage the internal parts of your Camcorder. Do not attempt to disassemble this unit. There are no user serviceable parts inside. Unplug your Camcorder from the power supply before cleaning.
- **DO NOT AIM YOUR CAMCORDER AT THE SUN OR OTHER BRIGHT OBJECTS.**
- **DO NOT LEAVE THE CAMCORDER WITH THE EVF AIMED DIRECTLY AT THE SUN AS THIS MAY CAUSE DAMAGE TO THE INTERNAL PARTS OF THE EVF.**
- **DO NOT EXPOSE YOUR CAMCORDER TO EXTENDED HIGH TEMPERATURE ...** Such as, in direct sunlight, inside a closed car, next to a heater, etc... This action could permanently damage the internal parts of your Camcorder.
- **AVOID SUDDEN CHANGES IN TEMPERATURE ...** If the unit is suddenly moved from a cold place to a warm place, moisture may form on the tape and inside the unit.
- **DO NOT LEAVE YOUR CAMCORDER OR THE POWER SUPPLY TURNED ON WHEN NOT IN USE.**
- **STORAGE OF YOUR CAMCORDER ...** Store and handle your Camcorder in a manner that will not subject it to unnecessary movement (avoid shaking and striking). Your Camcorder contains a sensitive pick-up device which could be damaged by improper handling or storage.

CARE

- **TO CLEAN YOUR CAMCORDER ...** Do not use strong or abrasive detergents when cleaning your Camcorder body.
- **TO PROTECT THE LENS ...** Do not touch the surface of the lens with your hand. Use a commercial camcorder lens solution and lens paper when cleaning the lens. Improper cleaning can scratch the lens coating.
- **TO PROTECT THE FINISH OF YOUR CAMCORDER ...** Before handling your Camcorder, make sure your hands and face are free from any chemical products, such as suntan lotion, as it may damage the finish.

Table of Contents

Getting Started

Things You Should Know	2
Important Safeguards	4
Precautions	5
Self Demo Mode	8
Quick Operation Guide	9
Supplying Power	12
Cassette Information	15
Attaching Shoulder Strap/Remote Holder	16
MENU Mode	17
Setting the Clock	19
Built-in Auto Light	22

Basic Operation

Camera Recording	23
8-Function Remote Control	28
Playing Back Recordings	29
Copying your Tapes (dubbing)	33

Special Features

Four-Speed Power Zoom	34
Backlight	34
Focus	35
High Speed Shutter	36
Tally Lamp	37
Color Digital Filter	38
Auto Fade	39
Color Digital Fade	40
Digital Zoom	42
Digital Electronic Image Stabilization (E.I.S.)	43
Still/Strobe/Wide	44
Security Mode	45
Intelligent Titler	46
Digital Still Camera	49
CompactFlash Card Insertion/Removal	49
Recording	50
Using the Light	52
Playback	53
Displayed Directory/Image Number	54
Deleting Specific Image Pages	55
Deleting All Image Pages	56
Picture in Picture Wipe Title	57
Digital Wipe Mode	58
PhotoShot Title Library	59
PC Connection	60
Using a PCMCIA Adaptor (optional)	67

Table of Contents

For Your Information

Viewfinder/LCD Monitor Indications	68
Operation Notes	73
Replacing Clock/Remote Battery	74
Palmcorder Accessory System	75
Palmcorder Accessory Order Form	77
Specifications	78
Before Requesting Service	79
Request for Service Notice	81
Warranty	82
Index	84
Spanish Quick Use Guide/Guía Para Uso Rápido	86

Self Demo Mode

Self Demo mode is on when the screen at the right appears. Follow the steps below to turn it off.

Before you begin...

- Connect Camcorder to power source.

EVF or LCD monitor

Panasonic

ITS TAPES PLAY
IN YOUR VCR
YES, IT'S VHS!

26x LENS / 300x D.ZOOM
DIGITAL STABILIZATION
FULL-SIZE HEAD SYSTEM
AUTO/PHRASE TITLER

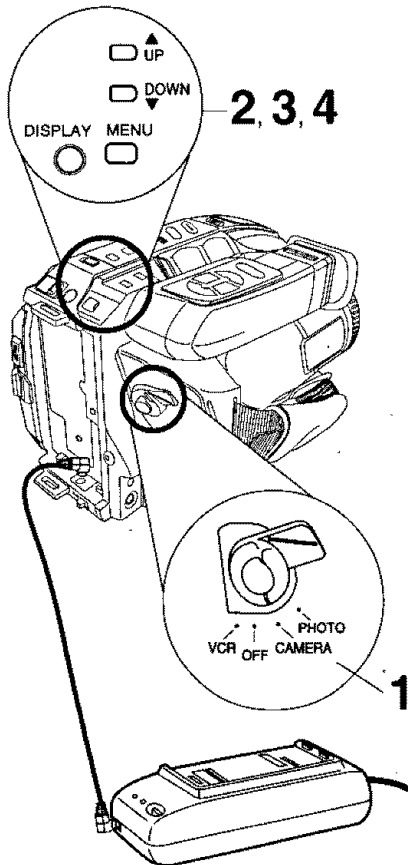

1 Set POWER to CAMERA.

2 Press MENU for MENU mode.
Press UP ▲ or DOWN ▼ to select
SELF DEMO.

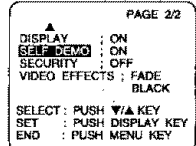

3 Press DISPLAY to select OFF.

4 Press MENU to exit.

Note:

- Self Demo stops automatically if battery is attached (page 12) and cassette tape is inserted (page 15).
- Inserting a tape alone (or attaching a partially charged battery) only temporarily stops Self Demo.
- Self Demo stops for 30 seconds when a function key other than Record/Pause, Tape Speed Selector, Light, Play, Rewind search, Fast forward search, Stop, and Still is pressed.

To turn Self Demo back on.

- Set to SELF DEMO : ON in MENU screen.

Quick Operation Guide

Charging the Battery Pack

Charge Battery Pack fully before operation (page 12).

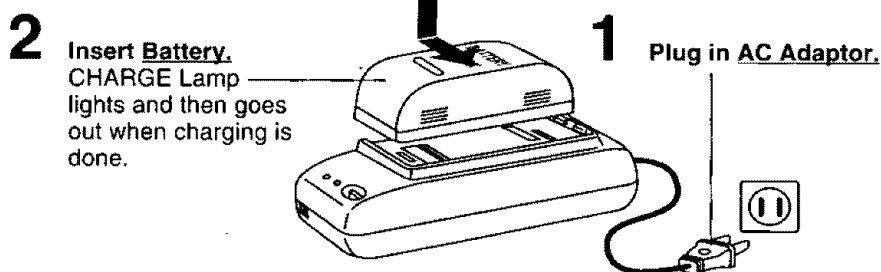

Insert the CompactFlash Card

When the CompactFlash Card is not inserted in CAMERA or PHOTO mode, "NO CF CARD" appears on-screen. Be sure to insert the CompactFlash Card before using the Built-in Digital Still Camera (page 49). CAMERA recording is possible even when the CompactFlash Card is not inserted.

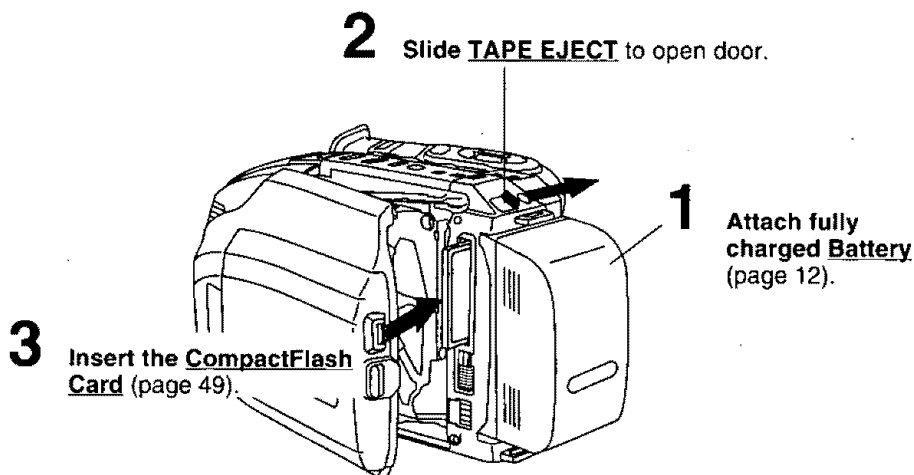

Quick Operation Guide

Insert Cassette

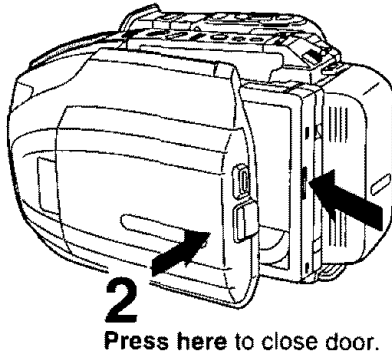

1 Insert cassette (page 15).

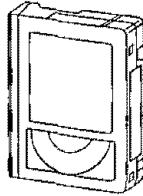

Camera Recording

When the LCD monitor is open, the EVF automatically turns OFF (page 24).

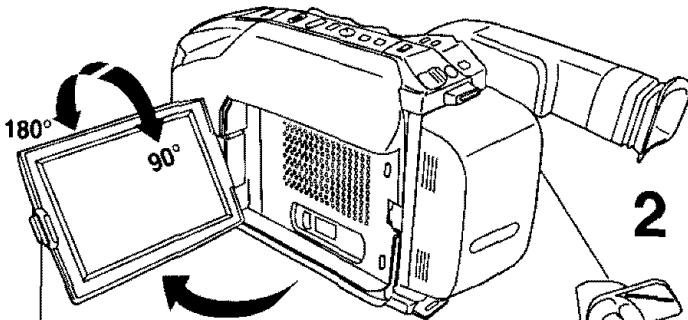

1 Press LCD-OPEN to unlock the LCD monitor. Swing it fully open and adjust the angle.

2 Set POWER to CAMERA.

3 Press RECORD/PAUSE to start recording. Press RECORD/PAUSE again to pause recording.

Quick Operation Guide

Playback using the LCD Monitor

When the LCD monitor is open, the EVF automatically turns OFF (page 29).

Before you begin...

- Charge Battery Pack fully before operation (page 12).

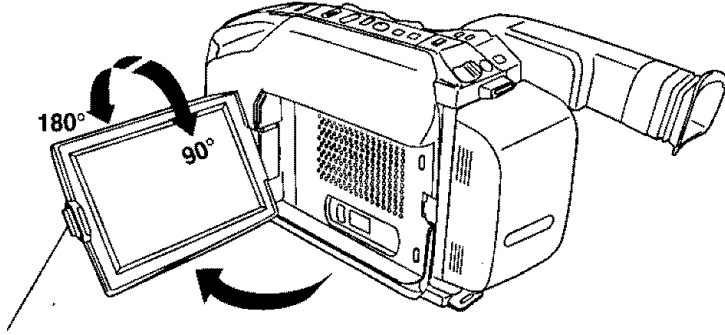

- 1** Press **LCD-OPEN** to unlock the LCD monitor. Swing it fully open and adjust the angle.

- 2** Set **POWER** to **VCR**.

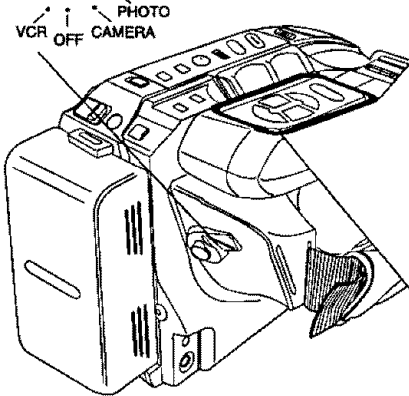
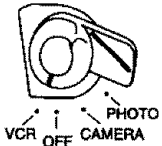

- 3** Press **REWIND/SEARCH** to rewind tape.

- 4** Press **PLAY** to start playback.

- 5** Press **STOP** to stop playback.

Supplying Power

Charging the Battery Pack

Charge Battery Pack fully before use.

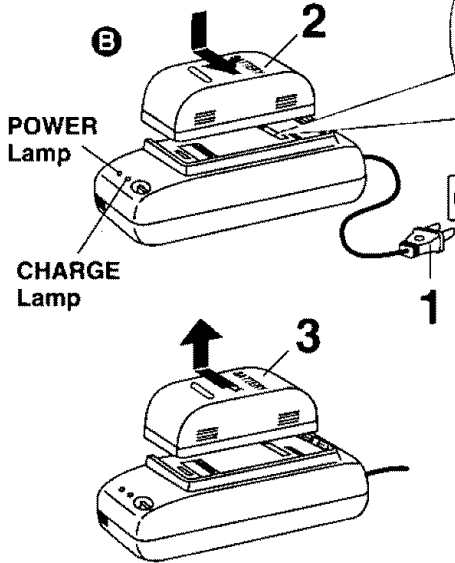

- 1 Plug in AC Adaptor.**
POWER Lamp lights.
- 2 Insert Battery.**
A Align right side of Battery with line on AC Adaptor.
B Press Battery down and slide in direction of arrow.
CHARGE Lamp lights and then goes out when charging is done (approx. 1 and 1/2 hours).
- 3 Remove Battery**
Slide Battery out and off.

Note:

After recharging 5 times, use BATTERY REFRESH feature as explained on page 13.

- Battery life gradually decreases after repeated use and recharging. If operation time becomes very short, even after a sufficient charge, discard Battery properly (page 13).

Using the Battery Pack

A fully charged Battery provides a maximum of about 2 hours of continuous use (LCD monitor off) or about 1.5 hours (LCD monitor on). Actual time may vary due to operating conditions. Using the Built-in Light decreases operating time.

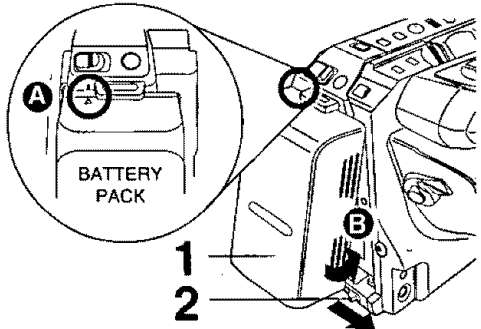

- 1 Attach Battery**
A Align Battery with top of mounting surface.
B Press and snap into place.
- 2 Remove Battery**
While sliding **BATTERY RELEASE**, remove Battery.

Supplying Power

Battery Refresh

This feature completely discharges Battery before recharging begins. Use after about every 5 charges for optimum Battery performance.

CHARGE Lamp

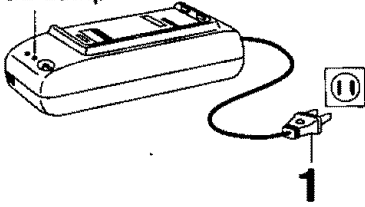

1

Plug in AC Adaptor.

- POWER Lamp stays on as long as Adaptor is plugged in.

2

Place Battery into Adaptor.

3

Press BATTERY REFRESH.

The CHARGE Lamp flashes during discharge then stays lit until charging is complete.

If BATTERY REFRESH is pressed by mistake, remove Battery from Adaptor and reinsert it for normal charging.

4

Remove Battery.

- Charging takes about 7 and 1/2 hours when Battery Refresh is used.
- Battery will not operate in extremely high temperatures.

Battery Care

Caution:

- Charge only with specified charger.
- Battery can be charged within a temperature range of 10 °C (50 °F) and 35 °C (95 °F).
- Battery is normally warm after charging or just after use.
- Do not use an insufficiently charged or worn-out Battery.

Safety precautions:

- Do not get Battery near, or dispose of in fire.
- Do not directly connect (short circuit) the positive (+) and negative (-) terminals.
- Never attempt to disassemble or reassemble Battery.

To avoid Battery damage:

- Do not drop or jar Battery.
- Use Battery with specified units only.
- If Battery is used in extremely high temperatures, a safety device will automatically prevent operation.

To prolong Battery life:

- While not in use, remove Battery from the Camcorder and AC Adaptor and store in a cool, dark, dry place.
- Keep Battery terminals clean.

U.S.A. CONSUMERS:

ATTENTION:

The product you have purchased is powered by a nickel cadmium battery which is recyclable. At the end of its useful life, under various state and local laws, it is illegal to dispose of this battery into your municipal waste stream. Please call 1-800-8-BATTERY for information on how to recycle this battery.



Supplying Power

AC Adaptor

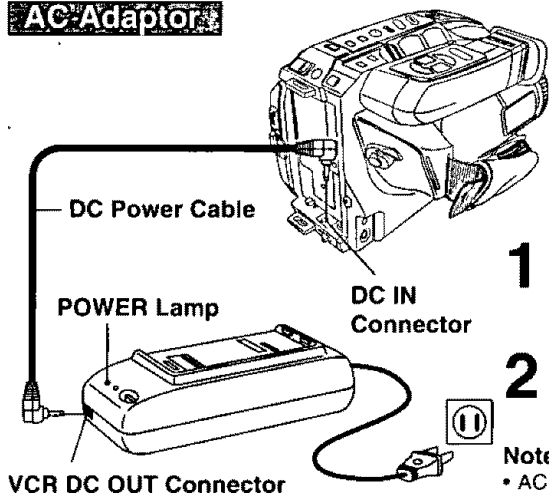

- 1 **Connect AC Adaptor VCR DC OUT to Camcorder DC IN** with supplied DC Power Cable.
- 2 **Plug in AC Adaptor.** POWER Lamp lights.

Notes:

- AC Adaptor cannot power Camcorder while charging Battery.
- When not in use, unplug AC Adaptor from AC outlet. (Adaptor uses 1.2 W of electricity while plugged in.)

CAUTION:

This unit will operate on 110/120/220/240 V AC. An AC plug adaptor may be required for voltages other than 120 V AC. Please contact either a local or foreign electrical parts distributor for assistance in selecting an alternate AC plug. We recommend using the accessory power plug adaptor (VJSS0070) in an area which has special AC outlets.

Car Battery Cord (Optional)

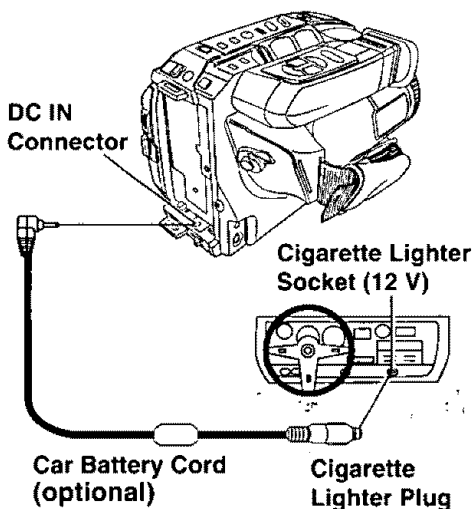

- 1 **Connect PV-C16 Car Battery Cord (optional, page 76) to Camcorder DC IN.**
- 2 **A Start engine first.**
B Plug Car Battery Cord into Cigarette lighter socket.
 - If Car Battery cord fuse needs replacing, use exact current rating (in amps).

Notes:

- This cord only works in vehicles equipped with DC 12 V (**negative ground**) battery. Check with your car/truck dealer. Use only specified car battery cord.
- To avoid blowing the car battery cord fuse, do step 2 in the proper order.
- Running vehicles must be well ventilated.
- When not in use, disconnect cigarette lighter plug.

Cassette Information

Cassette Insertion/Removal

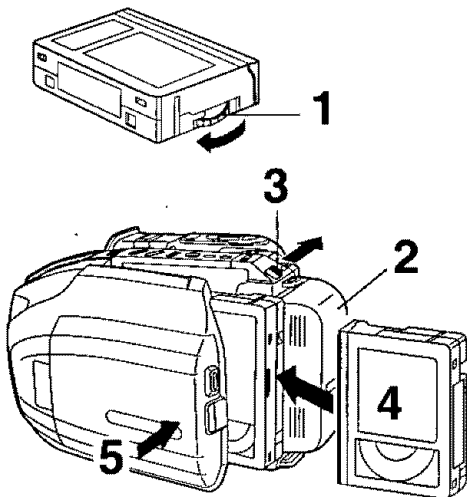

- 1 Turn **Tape Wheel** in direction of arrow until there is no slack.
- 2 Attach **Battery** (page 12).
- 3 Slide **TAPE EJECT** to open door.
- 4 Insert **cassette** as shown.
- 5 Press here to close door.

• To remove the cassette, slide the **TAPE EJECT** switch.

Record/Playback Time

Use tapes with the **VHSC** mark in this unit.

Tape Speed Selector Position	Cassette type		
	TC-20	TC-30	TC-40
SP (Standard Play)	20 minutes	30 minutes	40 minutes
SLP (Super Long Play)	1 hour	1 hour 30 minutes	2 hours

• SLP playback may contain more picture noise.

TAPE SPEED Selector

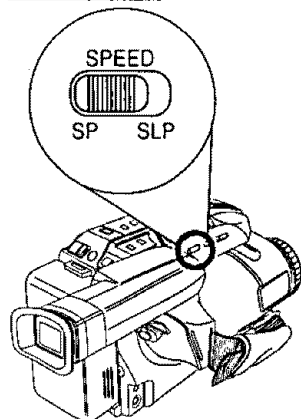

Erase Protection Tab

A record tab ensures recordings are not accidentally erased.

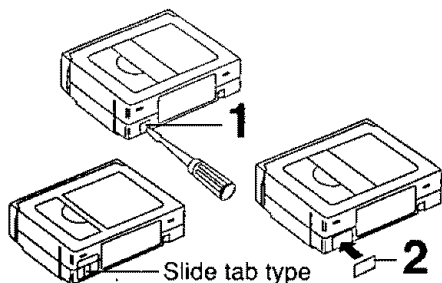

- 1 To prevent erasure, **break off tab** with screwdriver.
(Or, slide tab open.)
- 2 To record again, **cover hole** with adhesive tape.
(Or, slide tab closed.)

Attaching Shoulder Strap/Remote Holder

Remove Battery Pack before doing steps.

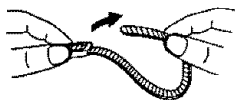

1 Undo strap ends from buckles.



2 Remove one buckle.

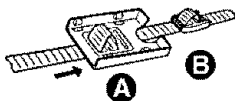

3 **A** Thread strap (with no buckle) through Remote Holder so it faces outward.
B Replace buckle.

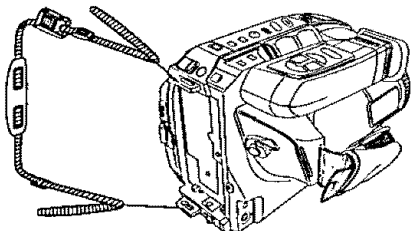

4 Thread strap ends through Strap Rings on Camcorder.



min. 25.4 mm (1 inch)

5 Re-insert the strap ends into buckles.

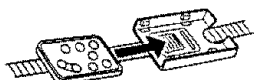

6 Insert Remote into Holder when not in use.

Adjusting the Length

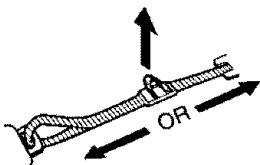

1 Pull a loop of strap from buckle.

2 Pull strap tight to shorten or lengthen.

Hand Strap

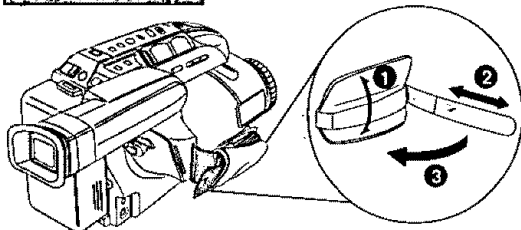

Adjust Hand Strap length to fit your hand as shown.

Using MENU Mode

Before you begin...

- Connect Camcorder to power source.
- Set POWER to CAMERA or VCR.

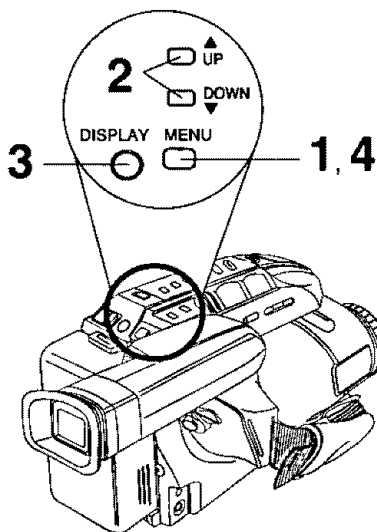

1 Press MENU for MENU mode.

```
--- MENU --- PAGE 1/2
PROGRAMMED REC
TITLE : AUTOMANUAL
TALLY LAMP : ON
STAND-BY RELEASE : OFF
CLOCK SET
SELECT : PUSH W/A KEY
SET : PUSH DISPLAY KEY
END : PUSH MENU KEY
```

CAMERA MODE

```
--- MENU ---
BLOCK SET
DISPLAY : ON
SELECT : PUSH W/A KEY
SET : PUSH DISPLAY KEY
END : PUSH MENU KEY
```

VCR MODE

2 Press UP ▲ or DOWN ▼ to highlight a menu item. Select a desired item.

3 Press DISPLAY to set selection.

4 Press MENU to exit.

Note:

- The Menu mode is canceled if UP/DOWN(▲/▼), DISPLAY, or MENU are not pressed within 5 minutes when Self Demo mode is off.
- The Menu mode is canceled if UP/DOWN(▲/▼), DISPLAY, or MENU are not pressed within 30 seconds when Self Demo mode is on.

MENU Mode

MENU Mode Screen (CAMERA MODE)

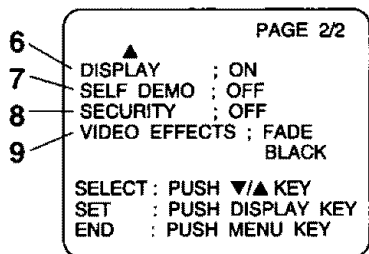
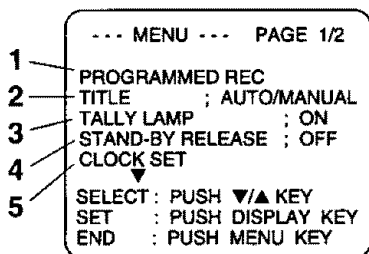

- 1 PROGRAMMED REC** (page 27).
Camcorder starts and stops recording at a preset time.
- 2 TITLE** (pages 46~48).
AUTO/MANUAL : 16 items
PHRASE : 10 items
- 3 TALLY LAMP** (page 37).
ON: lamp lights during recording.
- 4 STAND-BY RELEASE** (page 25).
ON: enables quick resumption of recording from Stand-by mode.
- 5 CLOCK SET** (pages 19~21).
Select to set clock.
- 6 DISPLAY** (page 68)
ON: On-screen Display (OSD) screens are displayed.
- 7 SELF DEMO** (page 8)
ON: SELF DEMO screen is displayed.
- 8 SECURITY** (pages 45).
ON: enables Motion Security recording.
- 9 VIDEO EFFECTS** (pages 38~41).
AUTO FADE : BLACK or WHITE
DIGITAL FADE : TYPE → 7 types
COLOR → 8 colors
DIGITAL FILTER : COLOR → 5 colors

MENU Mode Screen (VCR MODE)

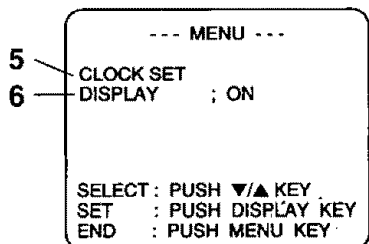

Setting the Clock

Set the following items in order: Time Zone, Daylight Saving Time, Date and Time.

Setting the Time Zone

The Camcorder is preset to Eastern time. To change time zone, do steps at right.

Before you begin...

- Connect Camcorder to power source.
- Set POWER to CAMERA or VCR.

Note:

- Clock may lose or gain up to 2 minutes per month. To adjust, see page 21.

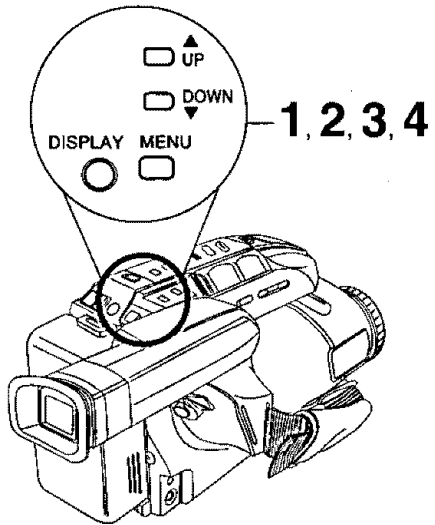

- 1 Press **MENU** for MENU mode. Press **UP ▲** or **DOWN ▼** to select **CLOCK SET**.

```

--- MENU --- PAGE 1/2
PROGRAMMED REC
TITLE      : AUTOMANUAL
TALLY LAMP : ON
STAND-BY RELEASE : OFF
CLOCK SET
SELECT : PUSH ▼/▲ KEY
SET    : PUSH DISPLAY KEY
END    : PUSH MENU KEY
  
```

CAMERA MODE

```

--- MENU ---
CLOCK SET : ON
DISPLAY
SELECT : PUSH ▼/▲ KEY
SET    : PUSH DISPLAY KEY
END    : PUSH MENU KEY
  
```

VCR MODE

- 2 Press **DISPLAY** for **CLOCK SET** menu. Press **UP ▲** or **DOWN ▼** to select **TIME ZONE**.

```

--- CLOCK SET ---
TIME ZONE : EASTERN
D. S. T.   : AUTO
DATE / TIME : 12:00 : 00AM
JAN 1 2000
SELECT : PUSH ▼/▲ KEY
SET    : PUSH DISPLAY KEY
END    : PUSH MENU KEY
  
```

- 3 Press **DISPLAY** for **SELECT TIME ZONE** menu. Press **UP ▲** or **DOWN ▼** to select local time zone.

```

--- SELECT TIME ZONE ---
ATLANTIC  PACIFIC
SELECTED ALASKA
CENTRAL  HAWAII
MOUNTAIN SAMOA
SELECT : PUSH ▼/▲ KEY
SET    : PUSH DISPLAY KEY
END    : PUSH MENU KEY
  
```

- 4 Press **DISPLAY** to confirm entry. Press **MENU** twice to exit.

- When traveling, repeat these steps and select one of the 8 listed time zones to set the clock to local time.

Time Zone chart

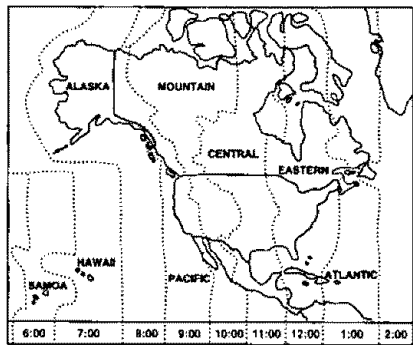

Note:

When traveling outside the listed time zones, set clock to local time manually (page 21).

Setting the Clock

Auto Daylight Saving Time

Clock will auto-adjust to daylight-saving time (DST).

The Camcorder is preset to DST: **AUTO**. If DST is not observed in your area, set to **OFF** by doing the following steps.

Before you begin...

- Connect Camcorder to power source.
- Set **POWER** to **CAMERA** or **VCR**.

Note:

- Auto DST does not function if time zone is set to Hawaii or Samoa (page 19).

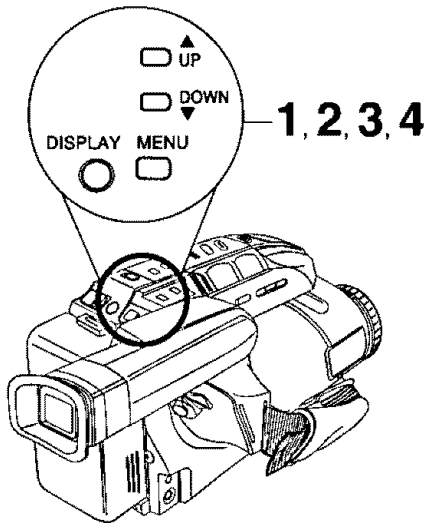

1

Press **MENU** for **MENU** mode. Press **UP ▲** or **DOWN ▼** to select **CLOCK SET**.

```
... MENU ... PAGE 1/2
PROGRAMMED REC.
TITLE ; AUTOMANUAL
TALLY LAMP ; ON
STAND-BY RELEASE ; OFF
CLOCK SET
SELECT : PUSH ▼/▲ KEY
SET : PUSH DISPLAY KEY
END : PUSH MENU KEY
```

CAMERA MODE

```
... MENU ...
CLOCK SET ; ON
DISPLAY ; ON
SELECT : PUSH ▼/▲ KEY
SET : PUSH DISPLAY KEY
END : PUSH MENU KEY
```

VCR MODE

2

Press **DISPLAY** for **CLOCK SET** menu. Press **UP ▲** or **DOWN ▼** to select **D.S.T.**

```
... CLOCK SET ...
TIME ZON ; EASTERN
D.S.T. ; AUTO
DATE / TIME : 12 : 00 : 00AM
JAN 1 2000
SELECT : PUSH ▼/▲ KEY
SET : PUSH DISPLAY KEY
END : PUSH MENU KEY
```

3

Press **DISPLAY** for **DAYLIGHT SAVING TIME** menu. Press **UP ▲** or **DOWN ▼** to select **OFF** or **AUTO**.

```
... DAYLIGHT SAVING TIME ...
AUTO
OFF
SELECT : PUSH ▼/▲ KEY
SET : PUSH DISPLAY KEY
```

4

Press **DISPLAY** to confirm entry. Press **MENU** twice to exit.

Spring (First Sunday in April):
DST: AUTO = ahead one hour.

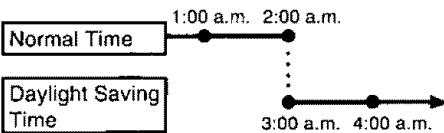

Autumn (Last Sunday in October):
DST: AUTO = back one hour.

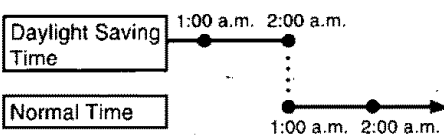

Setting the Clock

Setting Date and Time

Date and time including leap year are calculated up to DEC 31, 2098.

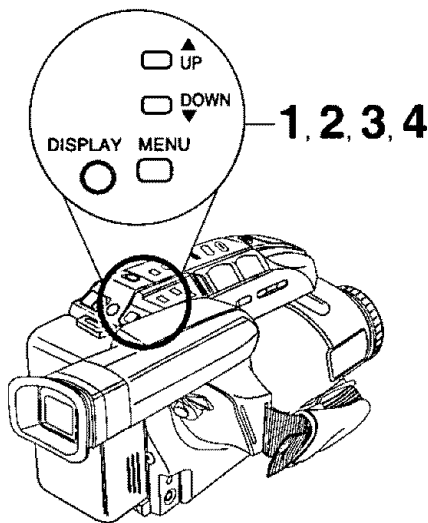

Before you begin...

- Connect Camcorder to power source.
- Set POWER to CAMERA or VCR.

- 1** Press **MENU** for MENU mode. Press **UP ▲** or **DOWN ▼** to select **CLOCK SET**.

```

--- MENU --- PAGE 1/2
PROGRAMMED REC
TITLE      ; AUTO/MANUAL
TALLY LAMP ; ON
STAND-BY RELEASE ; OFF
[RECORD]
SELECT : PUSH ▼/▲ KEY
SET    : PUSH DISPLAY KEY
END    : PUSH MENU KEY
  
```

CAMERA MODE

```

--- MENU ---
[CLOCK SET]
DISPLAY : ON
SELECT : PUSH ▼/▲ KEY
SET    : PUSH DISPLAY KEY
END    : PUSH MENU KEY
  
```

VCR MODE

- 2** Press **DISPLAY** for CLOCK SET menu. Press **UP ▲** or **DOWN ▼** to select **DATE/TIME**.

```

--- CLOCK SET ---
TIME ZON : EASTERN
D.S.T.   : AUTO
[DATE/TIME] : 12:00:00AM
              JAN 1 2000
SELECT : PUSH ▼/▲ KEY
SET    : PUSH DISPLAY KEY
END    : PUSH MENU KEY
  
```

- 3** Press **DISPLAY** for DATE/TIME menu.

```

--- DATE/TIME SETTING ---
-12:00:00AM-
JAN 1 2000
SELECT : PUSH ▼/▲ KEY
SET    : PUSH DISPLAY KEY
  
```

- 4** Press or hold down **UP ▲** or **DOWN ▼** to select hour, then press **DISPLAY** to fix.

Repeat for minute, month, day, and year. Clock starts when year is entered and **DISPLAY** is pressed.

Press **MENU** twice to exit.

EXAMPLE

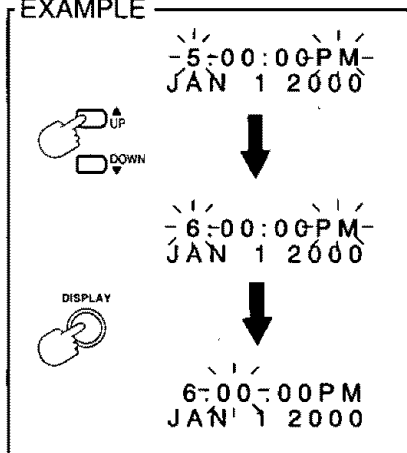

Built-in Auto Light

Using the Light

For recording in dim lighting.

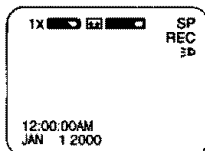
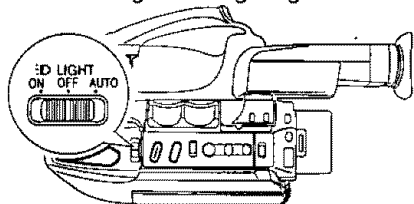

Before you begin...

- Connect Camcorder to power source.
- Set POWER to CAMERA.

Set LIGHT to AUTO.

Light turns on/off automatically according to lighting conditions.

Or, set LIGHT to ON/OFF manually.

☺ appears in EVF or LCD monitor when Light is on.

Caution:

Light becomes hot. Never cover Light while on.

Replacing the Bulb

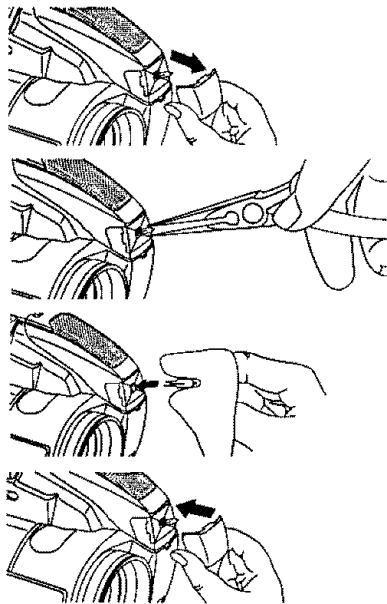

Before you begin...

- Order Part No. VULS0001 (VLLW0015 and cushions) for replacement bulb unit.
- Set POWER to OFF.

- 1 Press in on both sides of lens cover and pull straight out and off.
- 2 Using Tweezers or needle-nose pliers, carefully remove bulb.
 - Take unit to service center if you need assistance.
- 3 Replace bulb using a clean cloth or tissue.
- 4 Replace lens cover.

DANGER:

Use only replacement bulb (PART NO. VLLW0015) supplied by Panasonic to reduce risk of fire.

Handle new bulb with cloth or tissue as skin oils will decrease bulb life.

Remove lens cover and allow bulb to cool before replacing to avoid possible burn hazard.

Note:

- Using Light reduces battery operating time.
- Provide proper ventilation when using Light extensively in a hot environment.
- Using Light when the Camcorder is powered by a car battery may shorten bulb life.
- Set Light to OFF when not in use.
- Handle bulb gently. Excessive force may cause bulb to crack.

Camera Recording

Simple Recording

Before you begin...

- Connect Camcorder to power source.
- Insert cassette with record tab (page 15).

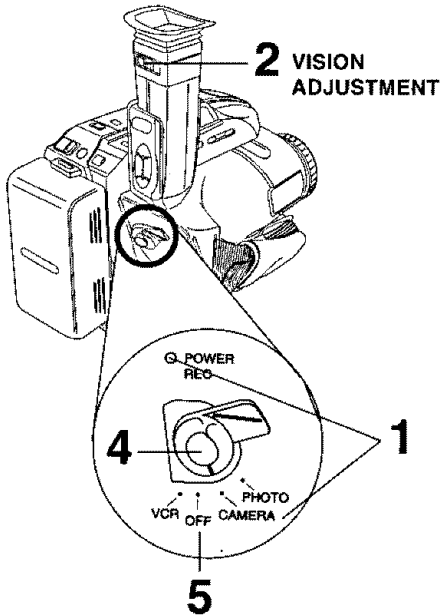

1 Set **POWER** to **CAMERA**.

Lens Cover opens.
Power lamp lights.

**EVF or LCD
monitor**

- Be sure **POWER** is fully turned to **CAMERA** position.

PAUSE

Record/Pause mode.

2 Look into EVF and adjust **VISION ADJUSTMENT** to your eyesight.

3 Slide **TAPE SPEED** to SP or SLP (page 15).

4 Press **RECORD/PAUSE** to start or pause recording. Tally lamp lights if set to ON (page 37).

RECORD

5 Set **POWER** to **OFF** when finished.

- **To remove cassette**, slide **TAPE EJECT** in Record/Pause mode. (page 15).

**Built-in Twin Capsule
2-Way Microphone
System**

Tally Lamp

Note:

- When Camcorder is aimed at excessively bright objects, or bright lights, a vertical bar may appear in the picture. This is normal for the CCD pick-up. Try to avoid this when possible.

Camera Recording

Using the LCD Monitor

View recording scene on the LCD (Liquid Crystal Display) monitor.

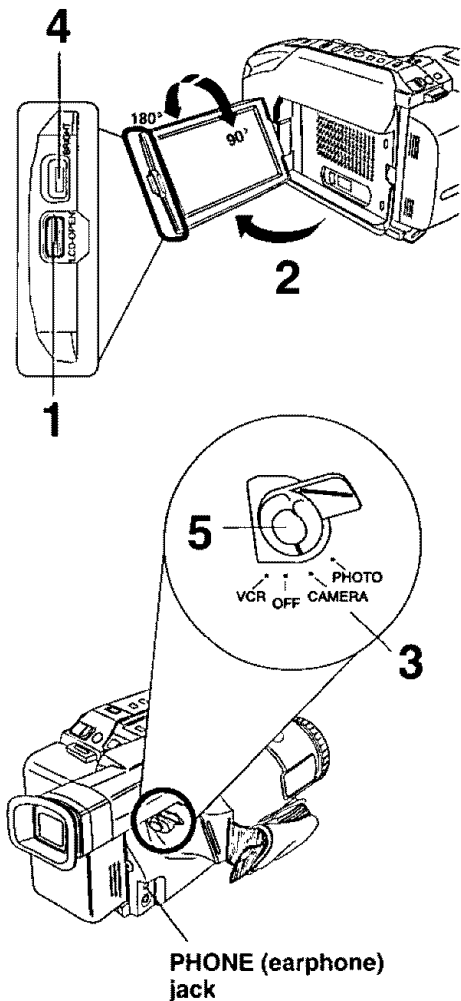

Before you begin...

- Connect Camcorder to power source.
- Insert cassette with record tab (page 15).

- 1** Press **LCD-OPEN** to unlock LCD monitor.
- 2** Swing LCD monitor fully open and adjust viewing angle.

Caution:

Rotating partially open LCD monitor may block cassette door and damage Camcorder body.

- 3** Set **POWER** to **CAMERA**.
 - EVF or LCD monitor turns on/off by the POWER switch.
 - EVF shuts off when LCD monitor is opened and turns back on when LCD is closed.
 - Both EVF and LCD monitor turn on when LCD is at 180° (see above left). This allows both you and the subject to view the recording.

- 4** Turn **BRIGHT** control to adjust LCD monitor brightness level.

- 5** Press **RECORD/PAUSE** to start recording (page 23).

Note:

- Using LCD monitor reduces battery operation time.
- Return LCD monitor to locked position when not in use.
- To hear sound while recording, connect earphone (M3 type: not supplied) to PHONE jack. Earphone volume cannot be changed while in CAMERA mode.

Camera Recording

Stand-by Quick Release

If left in RECORD/PAUSE mode for 5 minutes, Camcorder switches to Stand-by mode to conserve battery. When set to ON, Stand-by Quick Release lets you resume recording by pressing RECORD/PAUSE two times. New camcorders will default to OFF.

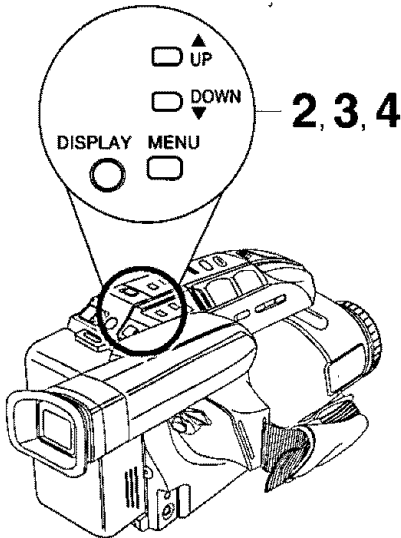
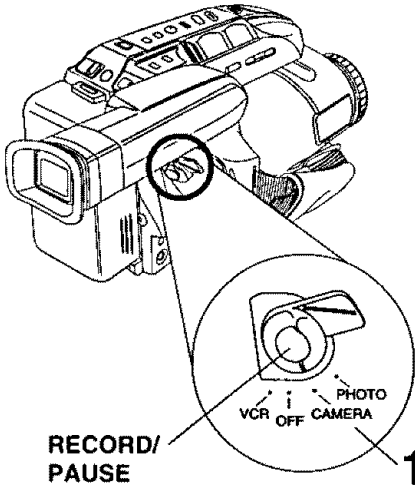

Before you begin...

- Connect Camcorder to power source.
- Insert cassette with record tab (page 15).

- 1 Set POWER to CAMERA.
- 2 Press MENU for MENU mode. Press UP ▲ or DOWN ▼ to select **STAND-BY RELEASE**.

```
... MENU ... PAGE 1/2
PROGRAMMED REC
TITLE          : AUTOMANUAL
TALLY LAMP    : ON
STAND-BY RELEASE : OFF
CLOCK SET
↓
SELECT : PUSH ▼/▲ KEY
SET     : PUSH DISPLAY KEY
END     : PUSH MENU KEY
```

- 3 Press DISPLAY to select ON/OFF.

ON: From Stand-by mode,
press RECORD/PAUSE two times
to resume recording.

OFF: From Stand-by mode,
set POWER to OFF, then to
CAMERA.
Press RECORD/PAUSE to record.

- 4 Press MENU to exit.

Camera Recording

Easy Edit Stand-by

For a smooth transition between scenes if recording is stopped, and then started within 24 hours.

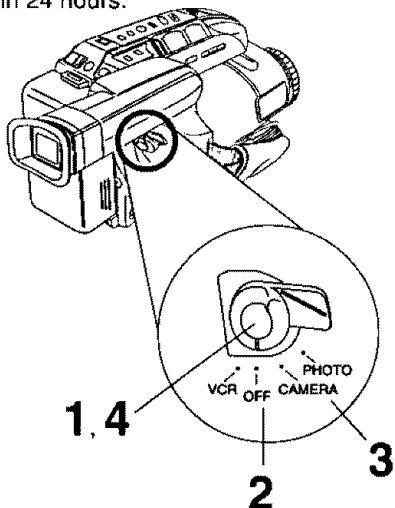

Before you begin...

- Connect Camcorder to power source.
- Insert cassette with record tab (page 15).

- 1 Press **RECORD/PAUSE** to stop recording.
- 2 Set **POWER** to **OFF** and leave cassette in Camcorder.
- 3 To resume recording, set **POWER** to **CAMERA**.
- 4 Press **RECORD/PAUSE** to resume recording.

Note:

- Use Manual Easy Edit (below) if more than 24 hours before recording is resumed.

Manual Easy Editing

For proper continuity when taping from Stop mode or after attaching a new Battery.

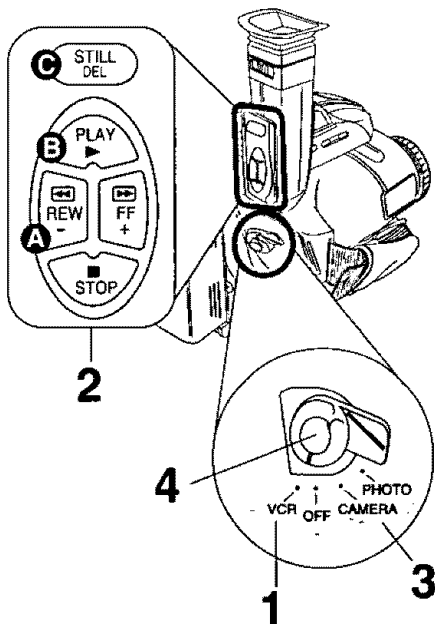

Before you begin...

- Connect Camcorder to power source.
- Insert cassette with record tab (page 15).

- 1 Set **POWER** to **VCR**.
- 2 **A** Press **REWIND/SEARCH** to rewind a few seconds of tape.
B Press **PLAY** to review recording.
C Press **STILL** where you want to continue recording.
- 3 Set **POWER** to **CAMERA**.
- 4 Press **RECORD/PAUSE** to resume recording.

Camera Recording

Programmed Recording

Set a recording start and stop time. Or, set a 5 or 10 second interval recording to be done each minute.

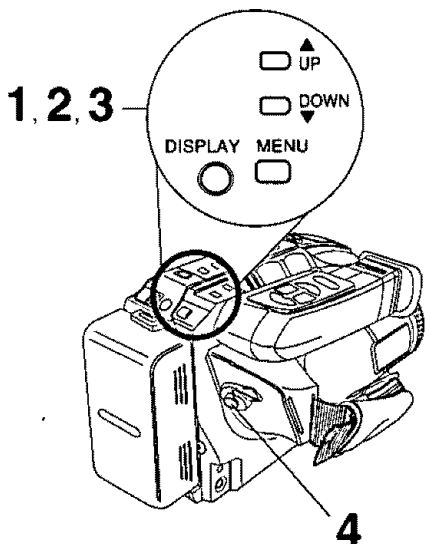

Before you begin...

- Connect Camcorder to power source. Use AC Adaptor for longer recordings.
- Insert cassette with record tab (page 15).
- Set POWER to CAMERA.

- 1 Press **MENU** for MENU mode. Press **UP ▲** or **DOWN ▼** to select **PROGRAMMED REC.**

```

--- MENU --- PAGE 1/2
PROGRAMMED REC
TITLE : AUTOMANUAL
TALLY LAMP : ON
STAND-BY RELEASE : OFF
CLOCK SET
SELECT : PUSH ▼/▲ KEY
SET : PUSH DISPLAY KEY
END : PUSH MENU KEY

```

- 2 Press **DISPLAY**. (Current time is displayed.) Each additional press of **DISPLAY** increases start time by 30 minutes.

```

START : 10:20PM
REC TIME : 10MIN.
SELECT : PUSH ▼/▲ KEY
SET : PUSH DISPLAY KEY
START : PUSH RECORD KEY
CANCEL : PUSH MENU KEY
10:20:00PM

```

- 3 Press **DOWN ▼** to select **REC TIME**. Press **DISPLAY** repeatedly to select one of the options shown at the left.

```

START : 10:20PM
REC TIME : 10MIN.
SELECT : PUSH ▼/▲ KEY
SET : PUSH DISPLAY KEY
START : PUSH RECORD KEY
CANCEL : PUSH MENU KEY
10:20:00PM

```

To cancel the setup, press **MENU** twice.

- 4 Press **RECORD/PAUSE** to place Camcorder in stand-by mode.

```

STAND-BY
START : 10:20PM
REC TIME : 10MIN.
10:20:00PM
JUN 1 2000

```

Recording will be done as scheduled.

```

10MIN. -- 20MIN. -- 30MIN. -- TO TAPE END
INTERVAL *2  INTERVAL *1
10 SEC/MIN.  5 SEC/MIN.

```

- *1 Interval 5 SEC/MIN:
Record 5 seconds each minute.
- *2 Interval 10 SEC/MIN:
Record 10 seconds each minute.

Note:

- Start time may not be set over 24 hours from current time.
- Camcorder shuts off at tape end, or 12 hours after Interval Recording starts.
- To cancel, set **POWER** to **OFF**.

8-Function Remote Control

Remote Control Holder

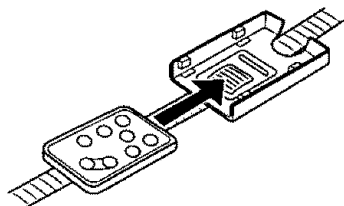

When not in use, slide remote into its holder on the shoulder strap (page 16).

Remote Control Operation

Operate Camcorder's main function up to about 5 m (16 feet) away.
Aim remote at sensor on Camcorder.

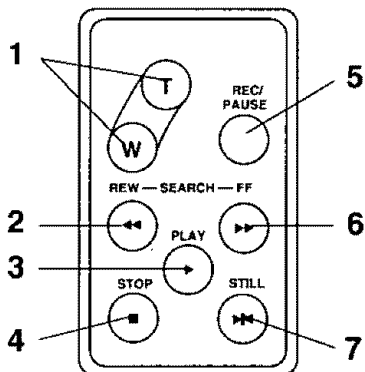

Controlled Functions

- 1 POWER ZOOM**
page 34.
- 2 REWIND/SEARCH**
page 29.
- 3 PLAY**
page 29.
- 4 STOP**
page 29.
- 5 RECORD/PAUSE**
page 23.
- 6 FAST FORWARD/SEARCH**
page 30.
- 7 STILL**
page 30.

Important Note:

- After 5 minutes in Rec/Pause mode, the camcorder will shut off to conserve battery power. If recording is resumed within 30 minutes, press **REC/PAUSE** once. If over 30 minutes, set **POWER** to **OFF**, then **CAMERA**, then press **REC/PAUSE**.

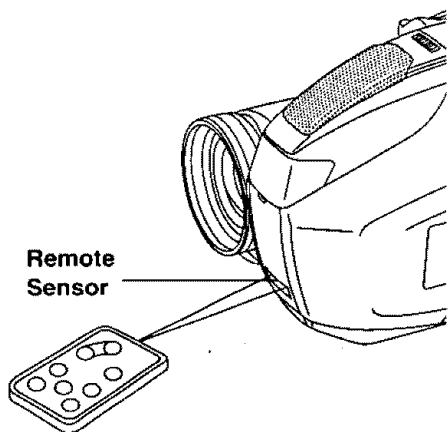

Playing Back Recordings

Playback on EVF or LCD Monitor

Before you begin...

- Connect Camcorder to power source.
- Insert recorded tape.

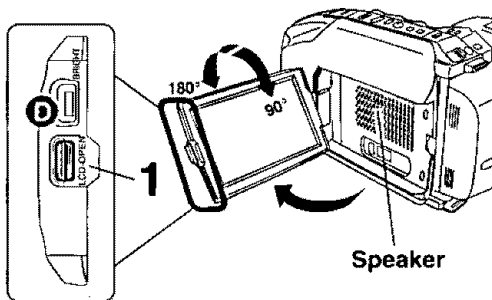

1 Press **LCD-OPEN** and swing LCD monitor fully open.

- If you want to playback on EVF, close and lock LCD monitor.

2 Set **POWER** to **VCR**.
Power lamp lights.

- If tape has no record tab, auto playback begins.
- EVF or LCD monitor turns on/off by the POWER switch.
- EVF shuts off when LCD monitor is opened and turns back on when LCD is closed.

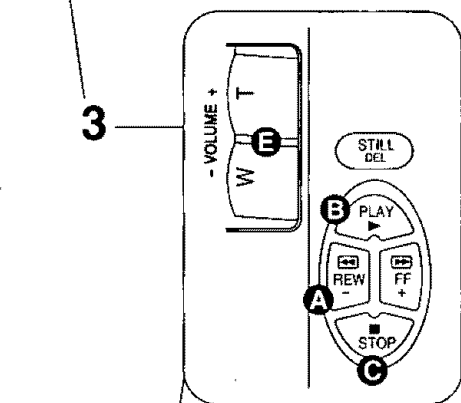

3 Playback function buttons.

- A** **REW(ind)** : Rewind tape.
- B** **PLAY** : Play tape.
- C** **STOP** : Stop tape.
- D** **BRIGHT** : Adjust LCD monitor brightness.
- E** **VOLUME** : Adjust volume of speaker, or earphone if connected.

Press "T" : Volume up(+).

Press "W" : Volume down(-).

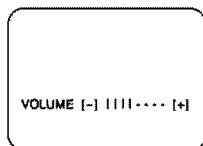
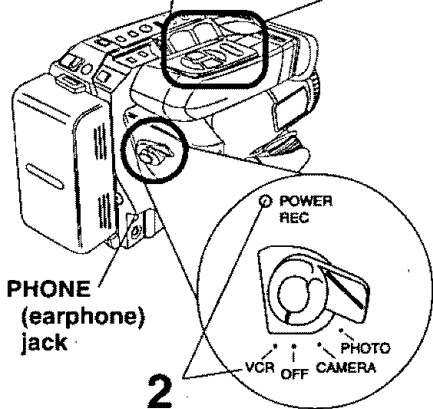

Note:

- Using LCD monitor reduces battery operating time.
- Return LCD monitor to locked position when not in use.
- When earphone (M3 type: not supplied) is connected to PHONE jack, speaker is muted.

Playing Back Recordings

Special Effects

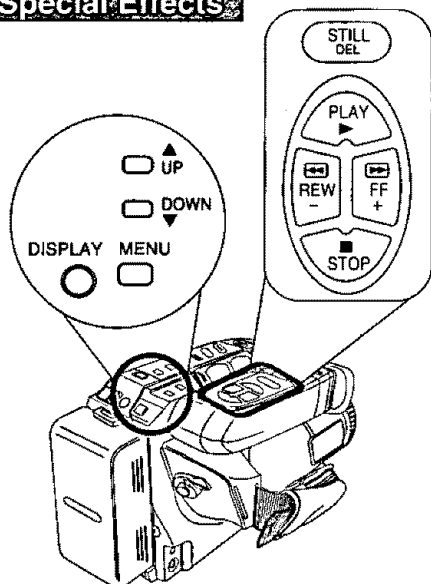

Note:

- During search, horizontal noise bars will appear. Audio is muted.
- To protect video heads and tape, operating modes will revert as follows after 5 minutes:
Still → Stand-by
Stand-by → Power off (when Battery Pack is used).
- Tape auto-rewinds if played or fast forwarded to end.

Tracking Control

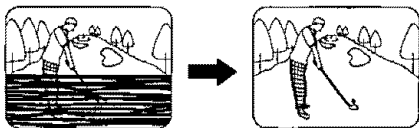

Auto Tracking

Continuously analyzes each recording for optimum picture quality.

Manual Tracking

Some recordings require manual adjustment to reduce noise.

In Playback mode:

Press UP ▲ or DOWN ▼ until Playback picture clears up.

Press DISPLAY to return to Auto Tracking.

Before you begin...

- Connect Palmcorder to power source.
- Insert recorded tape.
- Set POWER to VCR.

Quick Visual Search

Search Speed

SP (Standard Play) : 3 times normal.

SLP (Super Long Play) : 9 times normal.

During playback, press:

FF : fast forward search

REW : rewind search

Press again or press PLAY for normal play.

Still Picture

Press STILL to freeze picture.

Press again for normal play.

This feature works best in SLP mode (page 15).

Playing Back Recordings

TV Playback or Viewing

Connect Camcorder to a TV to view playback or recordings in progress.

TV with AUDIO/VIDEO IN Jacks.

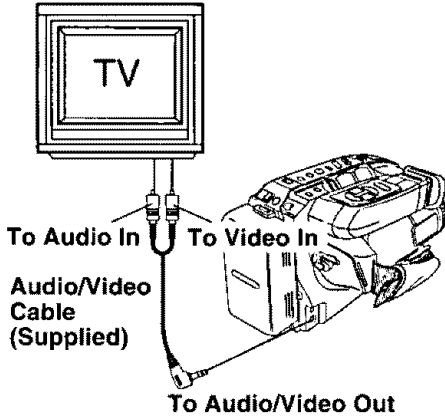

Before you begin...

- Connect Camcorder to power source.
- Make all TV-Camcorder connections.

- 1** Set **POWER** to:
VCR → view playback.
CAMERA → view picture as it is recorded.
- 2** Turn **TV ON** and set to **LINE INPUT**.
See TV owner's manual.
- 3** Begin playback or recording.

Basic Operation

TV without AUDIO/VIDEO IN Jacks.

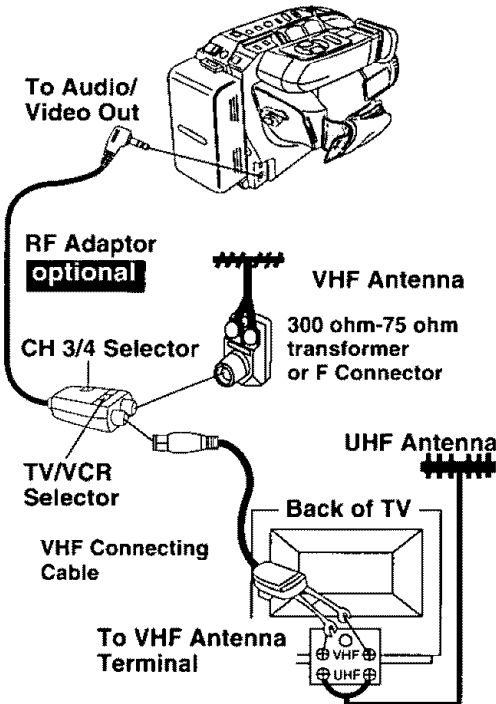

If TV has no **VIDEO/AUDIO IN** jacks, connect **PV-RF16 RF Adaptor** (optional, page 76). Tune TV to **CH 3** or **4** to match RF Adaptor **CH 3/4 Selector**. Set Adaptor's **TV/VCR Selector** to **VCR** for playback.

To watch TV only,

- a Set Camcorder **POWER** to **OFF**.
- b Set RF Adaptor **TV/VCR Selector** to **TV**.
- c Turn **TV ON** and select channel.

CATV System Installer

This reminder is provided to call the CATV system installer's attention to Article 820-40 of the NEC in USA (and to the Canadian Electrical Code in Canada) that provides guidelines for proper grounding and, in particular, specifies that the cable ground shall be connected to the grounding system of the building, as close to the point of cable entry as practical.

Playing Back Recordings in a VCR

Load Battery in PlayPak

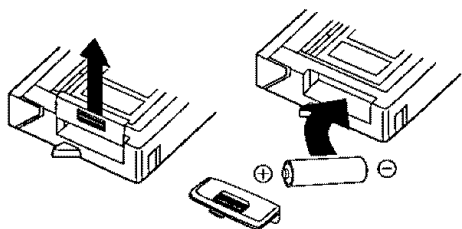

Remove Battery lid and insert AA battery.

- Do not reverse polarity.
- Replace battery when tape loading/unloading takes longer than usual.

Insert VHS Cassette in PlayPak

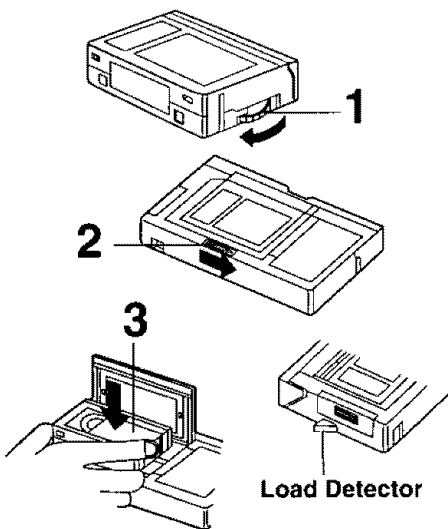

- 1 Turn **VHS** cassette **Tape Wheel** in direction of arrow to take up any slack.
- 2 Slide **RELEASE** to open cassette lid.
- 3 Insert the **VHS** cassette with the window up and on the left, then snap lid shut.
 - Do not obstruct cassette reel while loading.
 - Allow PlayPak Load Detector to fully retract before using in VHS VCR.

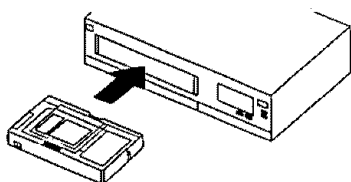

Remove VHS Cassette

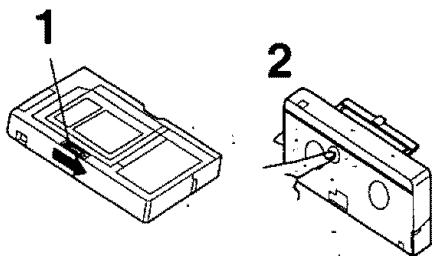

- 1 Slide **RELEASE** and wait for lid to open.
- 2 Push cassette out through hole in bottom of PlayPak with your finger.

Copying your Tapes (dubbing)

Connections

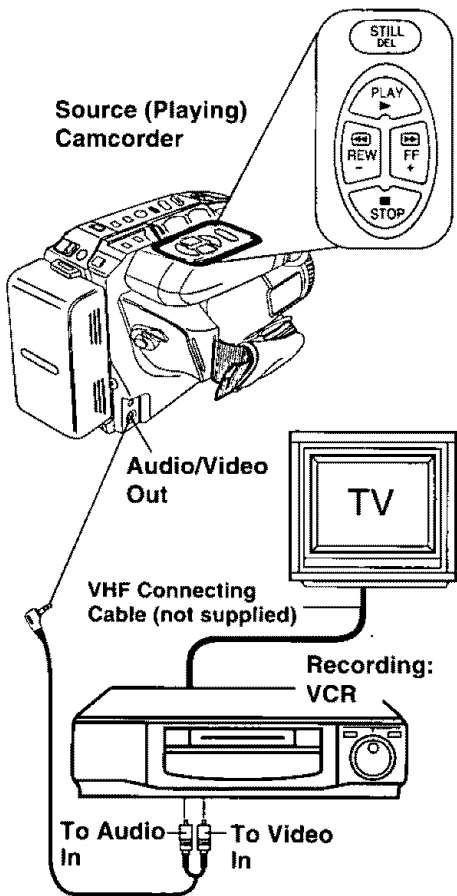

Audio/Video Cable (supplied)

Monitor with your TV

- Turn TV on and tune to VCR channel (CH3 or CH4).
- Set TV/VCR Selector on VCR to VCR.

Before you begin...

- Make Camcorder-VCR connections (see left).
- Turn both units on.
- Set VCR input signal to LINE. Please see VCR owner's manual.
- Set Camcorder POWER to VCR.

- 1 Insert a pre-recorded tape into Camcorder and a blank tape with record tab into VCR.
- 2 Press PLAY on Camcorder, then press STILL at starting point.
- 3 Press REC, then STILL/PAUSE on VCR.
- 4 Press STILL on Camcorder and STILL/PAUSE on VCR again to start copying.
- 5 Press STOP on both units to stop copying.

Note:

- Camcorder will only playback tapes recorded in SP or SLP mode.
- Dubbing may reduce picture quality.

CAUTION:

Unauthorized exchanging and/or copying of copyrighted recordings may be copyright infringement.

Power Zoom / Backlight

Four-Speed Power Zoom

Zoom in (close up) and out (wide angle) in one of four speeds ranging from slow (16 seconds) to fast (2 seconds).

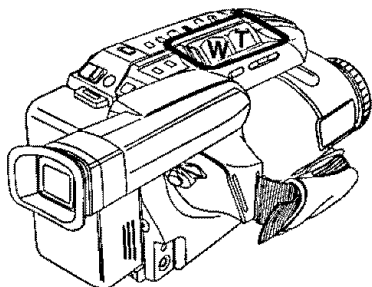

Before you begin...

- Connect Camcorder to power source.
- Set POWER to CAMERA.

Zoom In ("T")

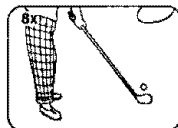

Zoom Out ("W")

Zoom slowly:

Lightly press "T" (telephoto) or "W" (wide angle) POWER ZOOM button.

Zoom quickly:

Apply more pressure to the button.

Backlight

Use when subject is darker than surroundings, in shadowed area, or in front of the light source.

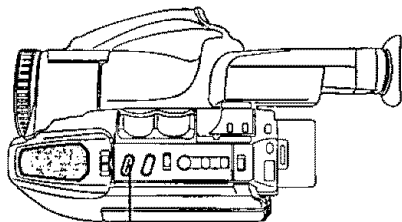

BACKLIGHT

Before you begin...

- Connect Camcorder to power source.
- Set POWER to CAMERA.

Press **BACKLIGHT** while recording to select the level of backlight compensation.

In normal lighting, press **BACKLIGHT** repeatedly until no indicator displayed.

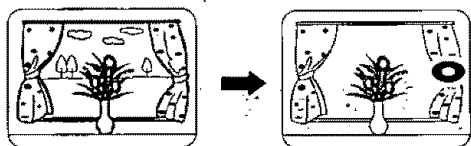

EVF or LCD monitor

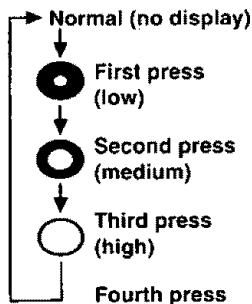

Auto Focus

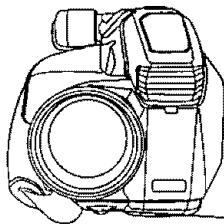

MANUAL FOCUS

Manual Focus

Use Manual Focus (MF) when :

- recording through glass.
- lighting is poor.
- subject is far away with objects in foreground.
- subject has distinct horizontal lines.

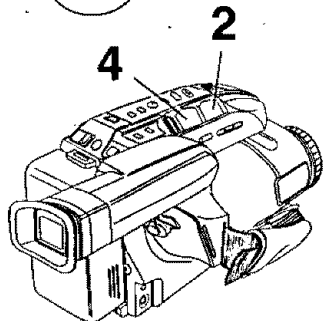
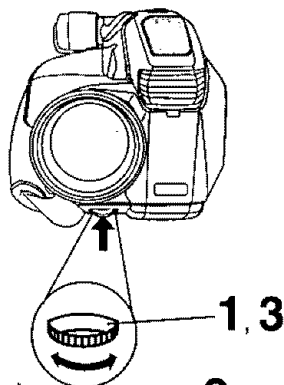

Before you begin...

- Connect Camcorder to power source.
- Set POWER to CAMERA.

Camcorder automatically focuses on subject even during zooming.

Auto Focus is on when "MF" is not displayed in EVF or LCD monitor. **Push MANUAL FOCUS** to remove "MF" in EVF or LCD monitor if necessary.

- subject is not centered in EVF or LCD monitor.
- subject has shiny surface.
- subject is slanted.
- subject is bright and flat, like a white wall.
- subject has fast motion, like a golf swing.

- 1** Push **MANUAL FOCUS** so "MF" (Manual Focus) appears in EVF or LCD monitor.

EVF or LCD monitor

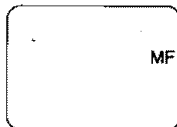

- 2** Hold down "**T**" (**telephoto**) on **POWER ZOOM** to maximum zoom in.

- 3** Turn **MANUAL FOCUS** until subject is in focus.
 - Back away from subject if necessary.

- 4** Hold down "**W**" (**wide angle**) on **POWER ZOOM** as desired.

- **Refocus as needed** when aiming at new scenes.

Macro Focus (close-ups)

Auto Focus functions up to 12.7 mm (1/2 inch) from subject.

Hold down "**W**" on **POWER ZOOM** to maximum wide angle.

Bring Camcorder up close to the subject.

High Speed Shutter

Improves Still or Slow Motion playback picture of high speed subjects (e.g. a tennis stroke), when viewed on Camcorder or 3- or 4 head VCR.

Before you begin...

- Connect Camcorder to power source.
- Set POWER to CAMERA.
- Insert cassette with record tab (page 15).

Auto Shutter

In AUTO mode (no indication in EVF or LCD monitor), shutter speed is auto-adjusted from 1/60 to 1/350 according to subject brightness.

- AUTO mode is selected each time POWER is set to CAMERA.

Manual Selection

The faster the shutter speed, the more light is needed for proper picture and color quality. High Speed Shutter indication flashes if light is inadequate. Provide additional light.

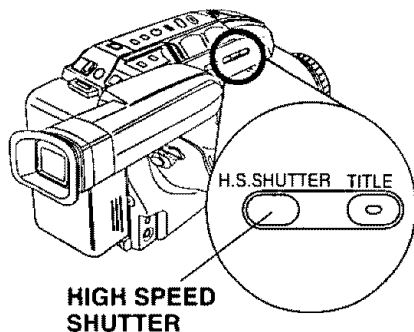

1 Press **HIGH SPEED SHUTTER** while recording.

2 Press repeatedly to change shutter speed. (See below, left.)

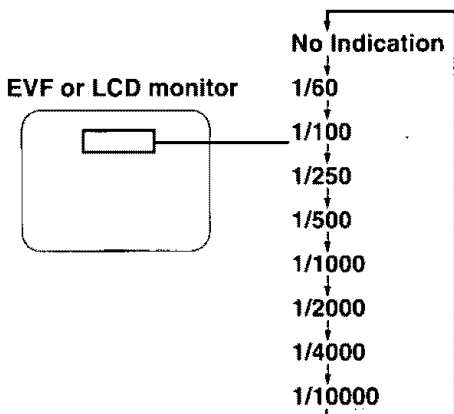

Note:

- Provide additional halogen or tungsten light for use indoors or in poor light. Fluorescent light degrades picture.
- Auto Focus may not function properly if high speed shutter is used in inadequate light.
- Setting reverts to AUTO each time POWER is set to CAMERA.

Tally Lamp

Tally Lamp

The tally lamp can be set to come on or stay off during recording. New camcorder's default setting is ON.

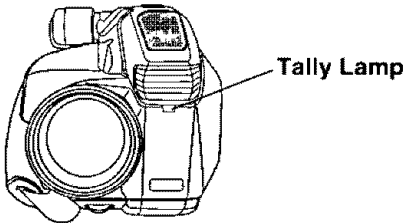
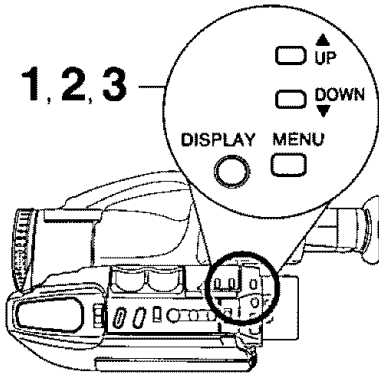

Before you begin...

- Connect Camcorder to power source.
- Set POWER to CAMERA.
- Insert cassette with record tab (page 15).

- 1** Press **MENU** for MENU mode. Press **UP ▲** or **DOWN ▼** to select **TALLY LAMP**.

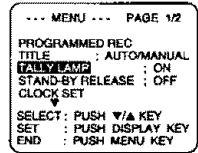

- 2** Press **DISPLAY** to select:
ON → Lamp lights during recording.
OFF → Lamp stays off.
- 3** Press **MENU** to exit.

Color Digital Filter

Digital Filter adds one of 5 colors to entire picture, like a color filter.

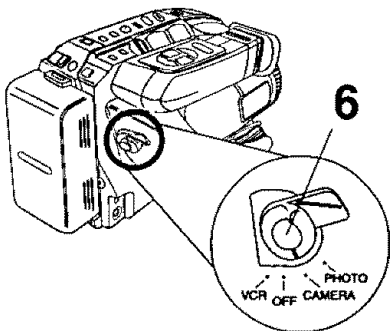
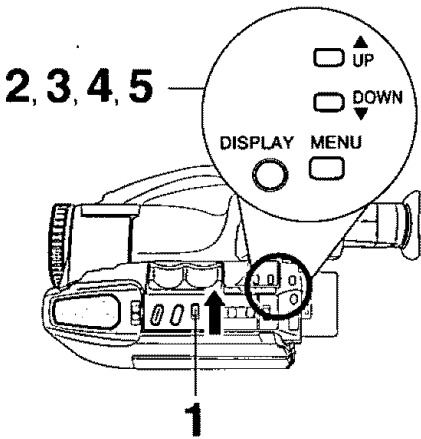

EVF or LCD monitor

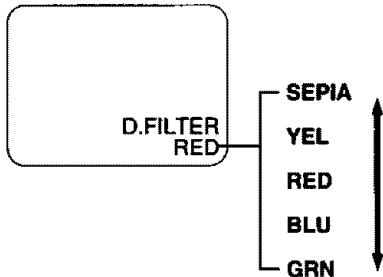

Before you begin...

- Connect Camcorder to power source.
- Set POWER to CAMERA.

1 Slide DIGITAL SELECT to FADE.

2 Press MENU for MENU mode.

Press UP ▲ or DOWN ▼ to select **VIDEO EFFECTS**.

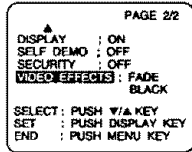

3 Press DISPLAY for VIDEO EFFECTS menu.

Press DOWN ▼ to select **DIGITAL FILTER**.

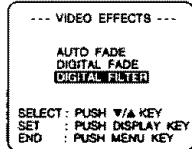

4 Press DISPLAY for DIGITAL FILTER menu. Press UP ▲ or DOWN ▼ to select from 5 colors.

- A preview of each color is displayed as it is selected.

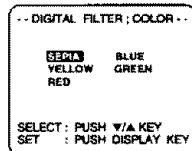

5 Press DISPLAY to confirm entry. Press MENU to exit.

6 Start recording (page 23).

- To cancel Digital Filter, set POWER to OFF.

Note:

- Color Digital Filter will not function during Digital Wipe mode, Picture in Picture Wipe Title or Still/Strobe/Wide.
- Picture returns to normal in Still mode.

Auto Fade

An interesting way to open and close scenes.

2, 3, 4, 5

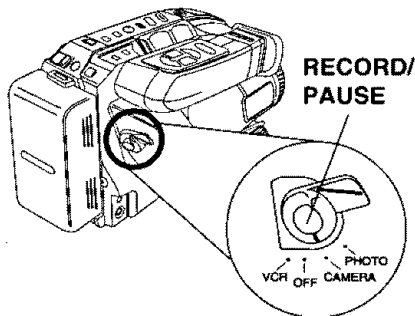
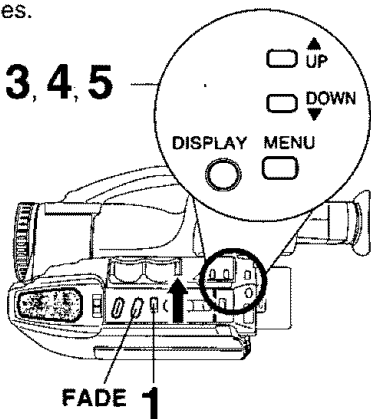

Fade In



WHITE

BLACK

Fade Out

Before you begin...

- Connect Camcorder to power source.
- Set POWER to CAMERA.

1 Slide **DIGITAL SELECT** to **FADE**.

2 Press **MENU** for **MENU** mode.
Press **UP ▲** or **DOWN ▼** to select **VIDEO EFFECTS**.

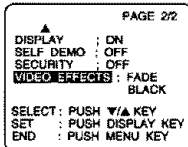

3 Press **DISPLAY** for **VIDEO EFFECTS** menu.
Press **UP ▲** or **DOWN ▼** to select **AUTO FADE**.

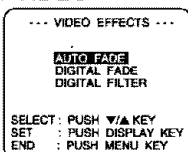

4 Press **DISPLAY** for **AUTO FADE**; **COLOR** menu.
Press **UP ▲** or **DOWN ▼** to select **BLACK** or **WHITE**.

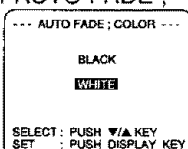

5 Press **DISPLAY** to confirm entry.
Press **MENU** to exit.

Fade In:

In **RECORD/PAUSE** mode, press **FADE** so "FADE" flashes in EVF or LCD monitor.

Press **RECORD/PAUSE**.

Recording starts as picture and sound gradually fade in.

Fade Out:

While recording, press **FADE** so "FADE" flashes in EVF or LCD monitor.

Press **RECORD/PAUSE**.

Picture and sound gradually fade out, and recording is paused.

If **FADE** is pressed accidentally, press again so "FADE" disappears in EVF or LCD monitor.

Note:

- Auto Fade will not function during Digital Wipe mode or Picture in Picture Wipe Title.

Fade

Color Digital Fade

Choose from 7 fade effects in 8 different colors.

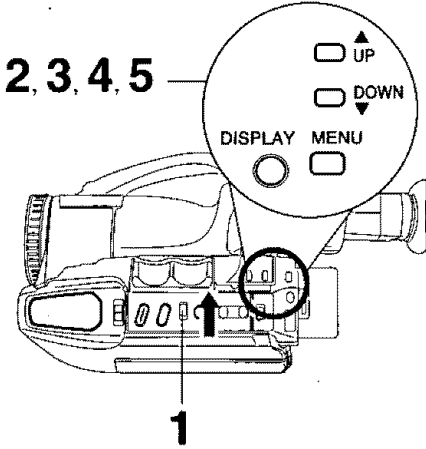

Before you begin...

- Connect Camcorder to power source.
- Set POWER to CAMERA.

1 Slide **DIGITAL SELECT** to **FADE**.

2 Press **MENU** for **MENU** mode. Press **UP ▲** or **DOWN ▼** to select **VIDEO EFFECTS**.

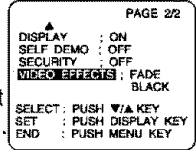

3 Press **DISPLAY** for **VIDEO EFFECTS** menu. Press **DOWN ▼** to select **DIGITAL FADE**.

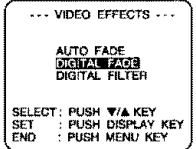

4 Press **DISPLAY** for **DIGITAL FADE** menu. Press **UP ▲** or **DOWN ▼** to select **TYPE**. Press **DISPLAY** for **TYPE** menu. Press **UP ▲** or **DOWN ▼** to select from 7 types.

- A preview of each fade type is displayed as it is selected.

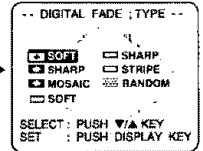
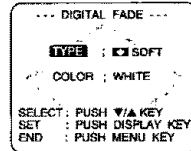

5 Press **DISPLAY** for **DIGITAL FADE** menu. Press **DOWN ▼** to select **COLOR**. Press **DISPLAY** for **COLOR** menu. Press **UP ▲** or **DOWN ▼** to select from 8 colors.

- A preview of each color is displayed as it is selected.

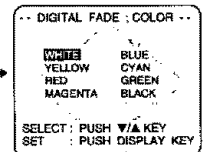
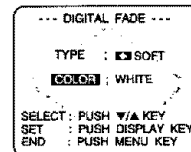

EVF or LCD monitor

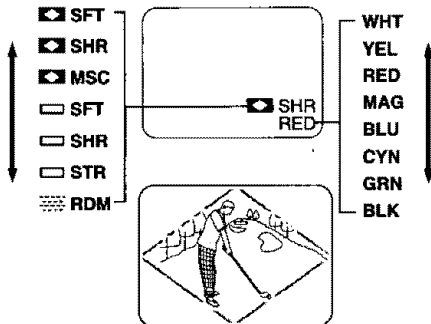

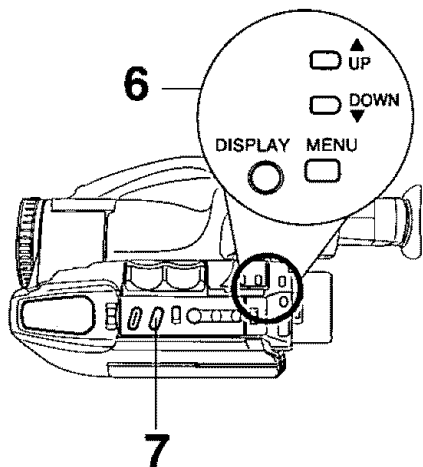

6 Press **DISPLAY** to confirm entry.
Press **MENU** twice to exit.

7 Press **FADE** for about 2 seconds to fade out during recording (selected fade type flashes). Press **FADE** again to fade in.

■ For more effects, stop fade in or fade out at any time (except **RANDOM** mode) by pressing **FADE**. Then, press **FADE** to resume fade.

Note:

- Audio is not affected by fade.
- To cancel Digital Fade, do steps 1, 2, 3, and 6. In step 3, select **AUTO FADE**.
- Color Digital Fade will not function during Digital Wipe mode or Picture in Picture Wipe Title.

Digital Zoom

Power Zoom magnification is digitally increased.

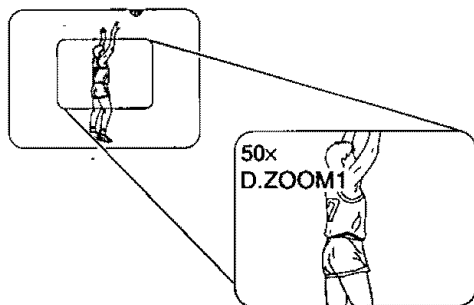
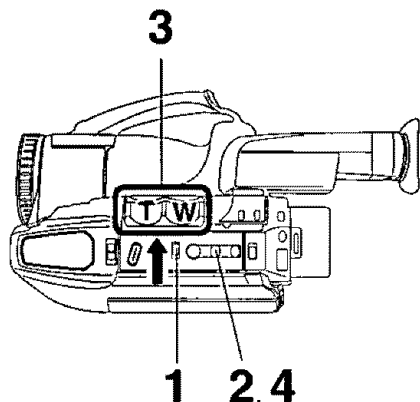

Before you begin...

- Connect Camcorder to power source.
- Set POWER to CAMERA.

1 Slide **DIGITAL SELECT** to **D.ZOOM**.

2 Press **D. ZOOM**.
once → D.ZOOM 1 (150x maximum)
twice → D.ZOOM 2 (300x maximum)

Higher digital magnification levels may cause picture distortion.

3 Hold down "**T**" on **POWER ZOOM**.
Digital Zoom starts when normal zoom reaches maximum (26x).

- Zoom level appears in EVF or LCD monitor.
- POWER ZOOM switch controls digital zoom level.
- Normal zoom resumes when level falls to 26x.

4 Press **D. ZOOM** to turn off Digital Zoom so no indication appears.

Note:

- If "NOW IN DIGITAL WIPE" is displayed when D. ZOOM is pressed, DIGITAL SELECT is currently in DIGITAL WIPE mode and the DIGITAL ZOOM feature is not available.

Digital Electronic Image Stabilization (E.I.S.)

Helps stabilize picture when recording in unstable situations.

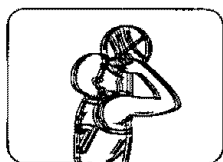
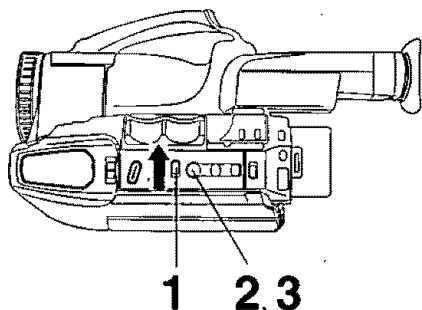

NORMAL

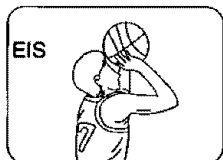

Digital EIS ON

Before you begin...

- Connect Camcorder to power source.
- Set POWER to CAMERA.

1 Slide **DIGITAL SELECT** to **EIS**.

2 Press **EIS** to display "EIS" in the EVF or LCD monitor.

- Image becomes slightly enlarged and shutter speed auto-adjusts from 1/80 to 1/350 according to brightness.
- Use High Speed Shutter (page 36) if needed. Shutter speed setting remains after EIS is canceled.

3 Press **EIS** again to cancel when not in use.

E.I.S. may not function during...

- extreme Camcorder movement.
- recording of subject with distinct horizontal or vertical stripes.
- low light situations (EIS indicator flashes).
- intense fluorescent lighting situations.
- recording of very fast motion.

Note:

- If "NOW IN DIGITAL WIPE" is displayed when EIS is pressed, DIGITAL SELECT is currently in DIGITAL WIPE mode and the Digital E.I.S. feature is not available.

Still/ Strobe/ Wide

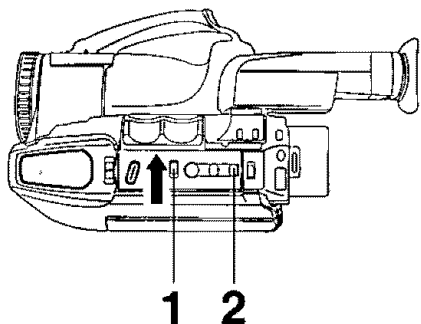

EVF or LCD monitor

Still



Strobe

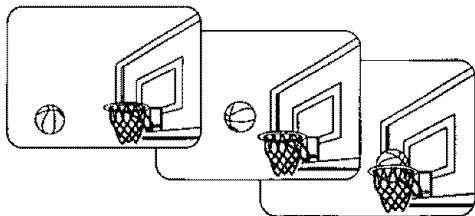

Wide Screen

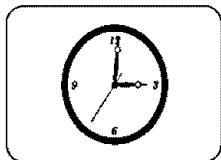
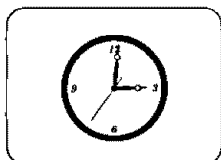

Normal

Wide

Before you begin...

- Connect Camcorder to power source.
- Set POWER to CAMERA.

1 Slide **DIGITAL SELECT** to **STILL/STROBE**.

2 Press **STILL/STROBE** repeatedly for desired function as described below.

Selection order

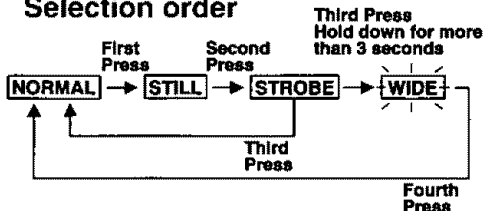

STILL

Records a still image from the current picture.

STROBE

Records a progression of still images in 1/6 of a sec. intervals.

WIDE SCREEN

Records a picture that will fill entire screen of a wide screen (16x9 aspect ratio) TV.

- Picture appears distorted in EVF or LCD monitor.

Note:

- If "NOW IN DIGITAL WIPE" is displayed when STILL/STROBE is pressed, DIGITAL SELECT is currently in DIGITAL WIPE mode and the STILL/STROBE/WIDE feature is not available.
- Wide screen recordings must be played back on a wide screen TV (16x9 aspect ratio) or picture will be distorted.
- If title is added (pages 46-48) during Wide mode, it will be distorted when played back on a wide screen TV.

Security Mode

Before you begin...

- Connect Camcorder to power source.
Use AC Adaptor for longer recordings.
- Insert cassette with record tab (page 15).
- Set **POWER** to **CAMERA**.
- Securely position and aim Camcorder.

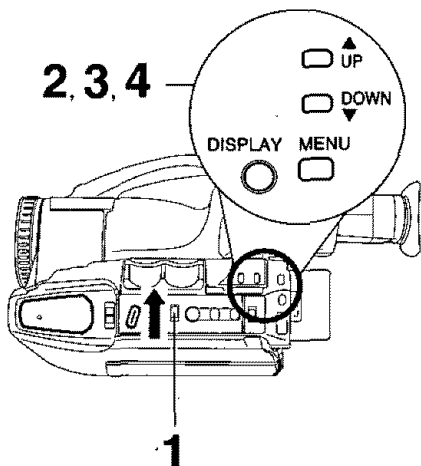

1 Slide **DIGITAL SELECT** to **EIS**.

2 Press **MENU** for MENU mode.
Press **UP ▲** or **DOWN ▼** to select **SECURITY**.

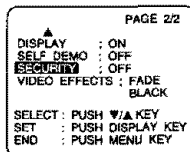

3 Press **DISPLAY** to select ON.

4 Press **MENU** for Motion Security stand-by mode. (If cassette is not inserted, "REC" will flash.)

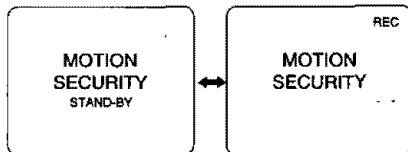

- Recording will start about 3 seconds after motion is detected.
- Date and time are recorded if displayed in EVF or LCD monitor (page 21).
- Recording stops 30 seconds after motion ceases.

Motion Security may mistakenly start when:

- background is plain, like a white wall, or has distinct vertical, horizontal or slanted stripes, like a venetian blind.
- brightness suddenly changes.

Motion Security may not start when:

- motion is very slow or fast.
- moving object is very small.
- motion occurs only in 1 corner of viewing area.
- in poor lighting (in this case, MOTION SECURITY flashes).
- background is plain, like a white wall, or has distinct horizontal or vertical stripes.

Note:

- Security recording starts if Camcorder is bumped or repositioned.
- This feature is not available during normal recording.
- While in Motion Security stand-by, the following functions are not available: Record/Pause, Stand-by mode, Digital E.I.S., Video Effects (Auto/Digital Fade, Digital Filter).

To cancel Security Mode, set **POWER** to **OFF**.

Intelligent Titler

Automatic Title

Camcorder auto-displays title greeting on selected holidays when power is first turned on. See title list on page 47.

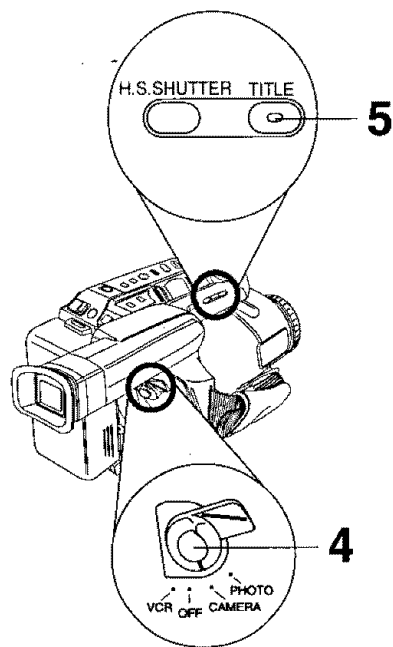
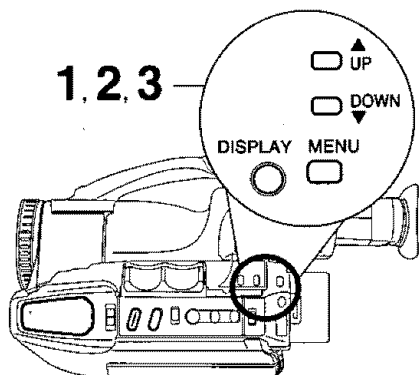

Before you begin...

- Connect Camcorder to power source.
- Set POWER to CAMERA.
- Insert cassette with record tab (page 15).

- 1 Press **MENU** for MENU mode. Press **UP ▲** or **DOWN ▼** to select **TITLE**.

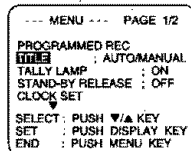

- 2 Press **DISPLAY** to select AUTO/MANUAL.
- 3 Press **MENU** to exit.
- 4 To record the title, press **RECORD/PAUSE**.
- 5 Press **TITLE** while recording to remove title.

Note:

- Once removed, title will not be auto-displayed. To redisplay, or select from other titles use Manual Title. (page 47).

Automatic/Manual Title Display List

Dec. 31–Jan. 1	HAPPY NEW YEAR! / CHEERS!
Feb. 14	VALENTINE'S DAY / BE MY VALENTINE
2nd Sunday in May	HAPPY MOTHER'S DAY / WE LOVE YOU!
Last Monday in May	MEMORIAL DAY
3rd Sunday in Jun.	HAPPY FATHER'S DAY / WE LOVE YOU!
Jul. 4	INDEPENDENCE DAY
1st Monday in Sep.	LABOR DAY
Oct. 31	HAPPY HALLOWEEN
4th Thursday in Nov.	HAPPY THANKSGIVING
Dec. 24–25	MERRY CHRISTMAS / HO! HO! HO!
These Titles must be displayed manually.	HAPPY EASTER HAPPY ANNIVERSARY HAPPY BIRTHDAY VACATION WEDDING DAY A SPECIAL DAY

Manual Title

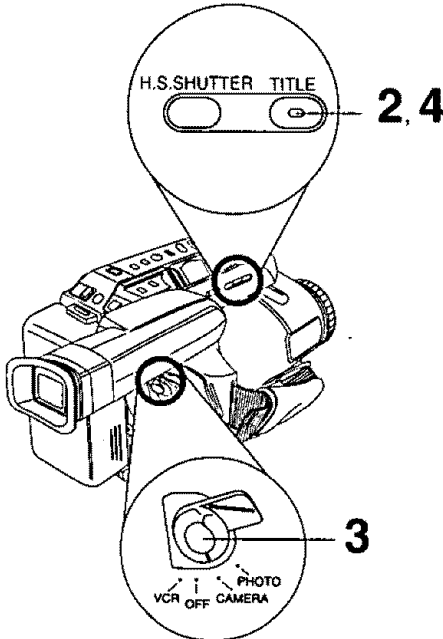

Before you begin...

- Connect Camcorder to power source.
- Set **POWER** to **CAMERA**.
- Insert cassette with record tab (page 15).

1 Confirm that **TITLE: AUTO/MANUAL** is set in Menu mode (steps 1–3, page 46).

2 In Pause (Record mode), press **TITLE** repeatedly to display titles from list above.

3 To record the title, Press **RECORD/ PAUSE**.

4 Press **TITLE** while recording to remove title.

Note:

- To redisplay title, press **TITLE** in Pause (Record mode).

Intelligent Titler

Phrase Title

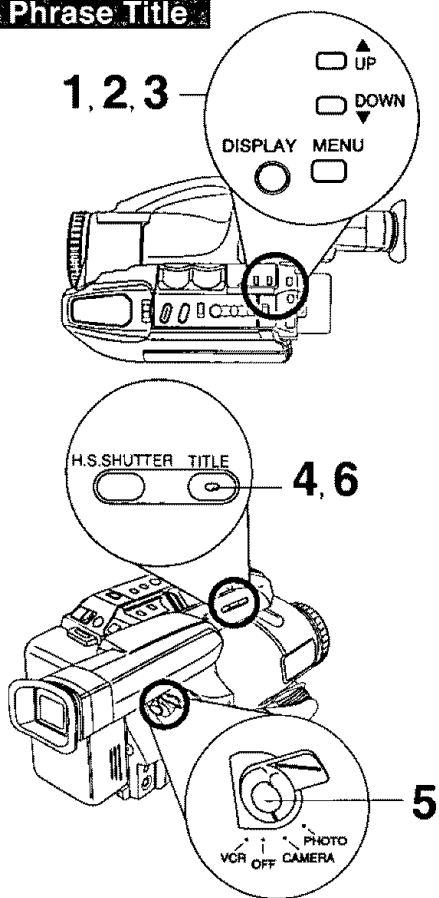

(no indication)

BEAUTIFUL

BRAVO!

CHEERS!

CONGRATULATIONS

GIMME A BREAK!

GOOD LUCK

I LOVE YOU

OOPS!

OUR LITTLE ANGEL

WAY TO GO

Before you begin...

- Connect Camcorder to power source.
- Set POWER to CAMERA.
- Insert cassette with record tab (page 15).

1

Press **MENU** for MENU mode.
Press **UP ▲** or **DOWN ▼** to select **TITLE**.

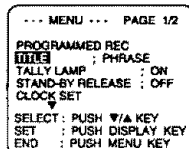

2

Press **DISPLAY** to select PHRASE.

3

Press **MENU** to exit.

4

In Pause (Record mode), press **TITLE** repeatedly to display phrases from list below, left.

5

To record the phrases, Press **RECORD/PAUSE**.

6

Press **TITLE** while recording to remove phrase.

Note:

- To redisplay phrase, press **TITLE** in Pause (Record mode).

Digital Still Camera

CompactFlash Card Insertion/Removal

The captured images will be stored on this CompactFlash Card.

Be sure to insert the CompactFlash Card before using the Built-in Digital Still Camera.

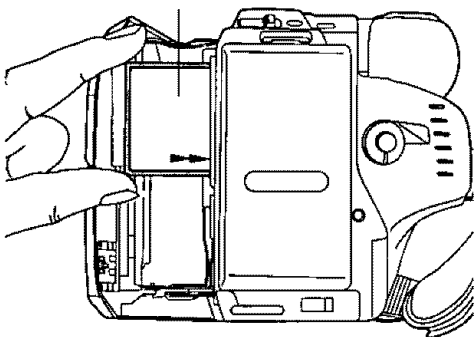
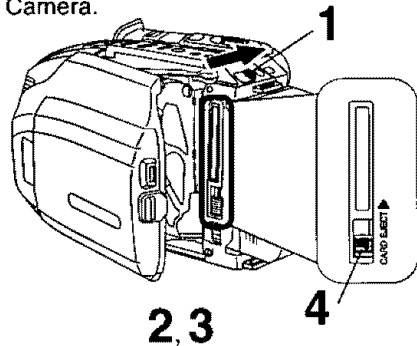

Before you begin...

- Connect Camcorder to power source.
- Set POWER to OFF.

1

Slide TAPE EJECT to open door.

2

Insert the **CompactFlash Card** into the CompactFlash Card Slot in the direction of the arrow. The side of the card with the arrow faces the back (battery side) of the camcorder (see the picture at the left).

3

Push the card fully into the Slot.

4

Slide CARD EJECT, to release the card.

Note:

- If CompactFlash Card is not inserted, "NO CF CARD" appears on-screen.
- Do not insert card in wrong direction.
- If card does not eject after sliding CARD EJECT, push card fully back into slot, then firmly slide the CARD EJECT again.
- To avoid dropping the card, do not slide CARD EJECT when the card slot is facing downward.
- If "CF CARD ERROR" appears on-screen, see page 80.

CAUTION:

- Do not bend, drop, apply high pressure or subject the card to strong shocks.
- Do not store it in places with high temperature, high humidity, a lot of dust, or places exposed to direct sunlight, or static electricity and strong electromagnetic waves.
- Keep the card's contacts free from dust, water or other foreign substances. Do not touch them with your fingers, etc.
- Do not disassemble or deform the card.
- Be sure to make a backup copy of important data.
- Do not affix other labels to the CompactFlash Card face or back as Card insertion/removal may become impossible.

Concerning the CompactFlash Card

- Except for some special features, this card is compatible with other Panasonic brand products, like Digital Camera (PV-DC1080, PV-DC1580, PV-DC2090, PV-DC2590), LCD Projector (PT-L556U).
- Panasonic only guarantees compatibility with Panasonic brand cards and those bearing the SanDisk logo.
- This Camcorder can capture a maximum of 699 still images because of camera memory capacity. A larger CF card (optional) is required to capture 699 images.
In order to capture 699 images, a CF Card memory with approx. 62 MB is needed for FINE mode and approx. 21 MB is needed for Normal mode.

Digital Still Camera

Recording

Before you begin...

- Connect Camcorder to power source.
- Insert the CompactFlash Card (page 49).

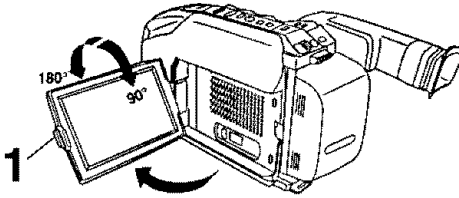

1 Press **LCD-OPEN** and swing LCD monitor fully open. Adjust viewing angle.

2 Set **POWER** to **PHOTO**. Built-in Lens Cover opens and Power lamp lights.
• Be sure **POWER** is fully rotated to **PHOTO** position.

3 Slide **PHOTO MODE** to **REC**.

4 Press **MENU** for REC Mode. Press **UP ▲** or **DOWN ▼** to select **NORMAL** or **FINE** (page 71). Then, press **DISPLAY** to set.

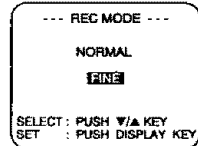
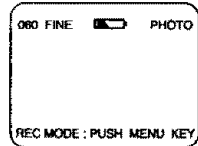
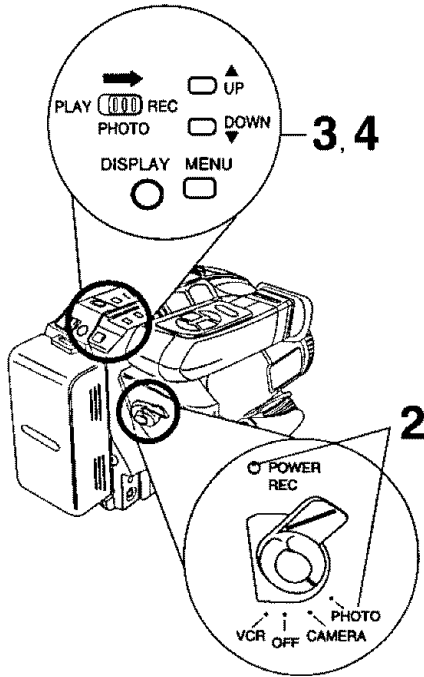

Note:

Please note that the included 8 MB CompactFlash Card already contains 12 pre-recorded titles for your use. Please see page 59 for further details.

Digital Still Camera

5

Press **RECORD/PAUSE** to capture image.

- As the image is processed, the status screens below appear. The next image may be captured after "COMPLETED" disappears.
- Depending on the image taken, the image page remaining indication may not change, or it may be decreased by 2 images.

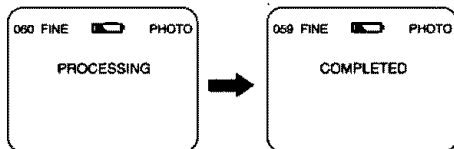
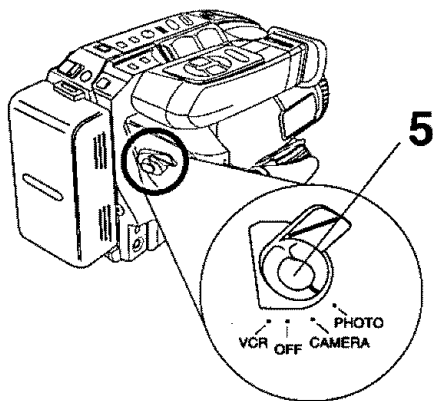

- For sharper images, set electronic shutter to higher speed when shooting in bright conditions, such as outdoors.

Note:

- If CompactFlash Card is not inserted, "NO CF CARD" appears on-screen. Set POWER to OFF, then insert the CompactFlash Card.
- If "CF CARD ERROR" appears on-screen, see page 80.
- Sound will not be recorded.
- The features below are not available while in PHOTO mode.
 - Auto Fade
 - Digital Fade
 - Color Digital Filter
 - Digital Zoom
 - Digital E.I.S.
 - Still/Strobe/Wide
 - Security Mode
 - Intelligent Titler
 - Digital Wipe Mode
 - Picture in Picture Wipe Title

WARNING:

Do not, under any circumstances, remove the card immediately after pressing the RECORD/PAUSE (during recording of an image) or while deleting. This could damage the format of the card and make it unusable.

Digital Still Camera

Using the Light

For capture of still images in dim lighting.

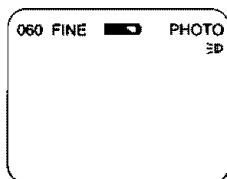
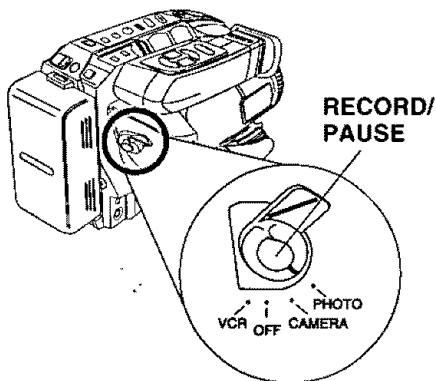
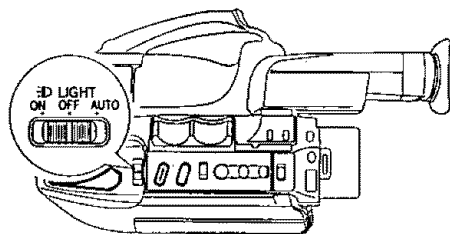

Before you begin...

- Connect Camcorder to power source.
- Insert the CompactFlash Card (page 49).
- Set POWER to PHOTO.

Set LIGHT to AUTO.

When **RECORD/PAUSE** is pressed to capture an image in dim lighting, the Light comes on for about 2 seconds, the image is captured, then goes out.

Or, set **LIGHT to ON/OFF** manually.

LD appears in EVF or LCD monitor when Light is on.

Caution:

Light becomes hot. Never cover Light while on.

Note:

- Using Light reduces battery operating time.
- Provide proper ventilation when using Light extensively in a hot environment.
- Using Light when the Camcorder is powered by a car battery may shorten bulb life.
- Set Light to OFF when not in use.

Digital Still Camera

Playback

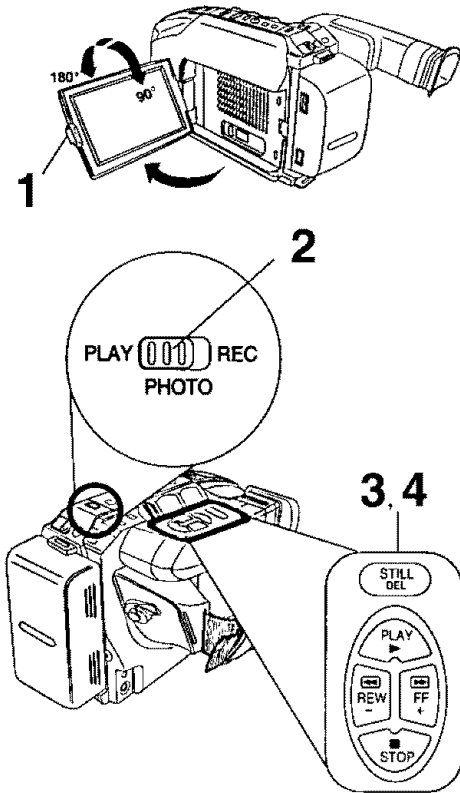

Note:

- If CompactFlash Card is not inserted, "NO CF CARD" appears on-screen. Set Power to OFF, then insert the CompactFlash Card.
- Pictures captured with other brand products cannot be used with this Camcorder.
- If "INCOMPATIBLE IMAGE" appears on-screen, the size of the captured image cannot be played back on this Camcorder.
- Do not change POWER setting to CAMERA or change recording mode while "PLEASE WAIT" is displayed.
- If "CF CARD ERROR" appears on-screen, see page 80.

Before you begin...

- Connect Camcorder to power source.
- Insert the CompactFlash Card (page 49).
- Set POWER to PHOTO.

1 Press **LCD-OPEN** and swing LCD monitor fully open. Adjust viewing angle.

2 Slide **PHOTO MODE** to **PLAY**. The Multi Image Playback screen appears. The last captured image screen is underlined.

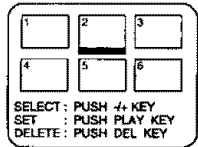

- If there are no recordings on the card, "NO PICTURE" appears on-screen.
- In NORMAL or FINE mode, the color of the Multi Image page number is as follows:
NORMAL mode → green
FINE mode → white

3 Press **+(FF)** → next. Press **-(REW)** → previous.

- The selected image will be underlined in green.
- Continue pressing + (FF) or - (REW) for next or previous page.

4 Press **PLAY** to display image. This screen appears followed by image.

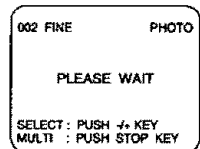

- Press **DISPLAY** to remove or redisplay this screen.
- Press **STOP** to redisplay Multi Image playback screen.

Digital Still Camera

Displayed Directory/Image Number

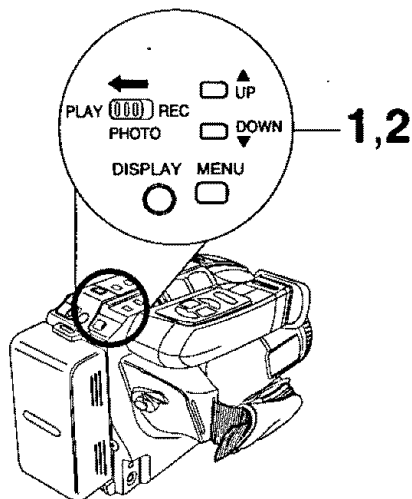

Before you begin...

- Connect Camcorder to power source.
- Insert the CompactFlash Card (page 49).
- Set POWER to PHOTO.

1 Repeat step 1 and 2 on page 53 to display Multi Image Playback screen. Select any image and press PLAY.

2 Press **MENU** for DCF NUMBER DISPLAY menu. Press **UP▲** or **DOWN▼** to select ON or OFF. Then, press **DISPLAY** to set.

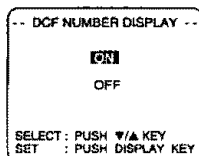

ON → Directory/Image Number is displayed.

OFF → Directory/Image Number is not displayed.

Directory/Image Number

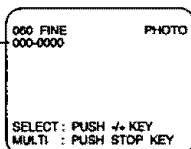

Note:

- Directory/Image Number "xxx-xxxx" (x indicates the number) is assigned automatically.
- Even if ON is set, if the Directory/Image Number dose not correspond with DCF it is not displayed.
- The Directory/Image Number becomes the folder and file name when viewed with card reader.

Digital Still Camera

Deleting Specific Image Pages

Delete older images to make room for new ones.

Important :

Once deleted, images cannot be restored.

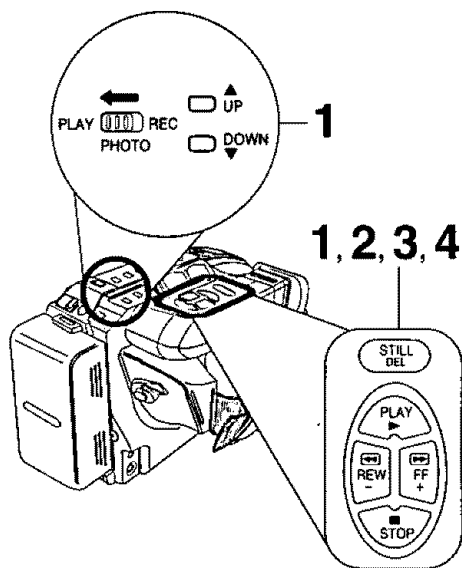

Before you begin...

- Connect Camcorder to power source.
- Insert the CompactFlash Card (page 49).
- Set POWER to PHOTO.
Slide PHOTO MODE to PLAY.

1 Press **DEL(STILL)** for **DELETE** menu. Press **UP ▲** or **DOWN ▼** to select **PAGE**.

- To exit menu at any time, press **STOP**.

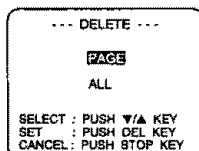

2 Press **DEL(STILL)** for Multi Image screen. Press **+** (**FF**) or **-** (**REW**) to select image page. Press **PLAY** once to set. Or, press twice to undo.

- Press **+** (**FF**) or **-** (**REW**) and **PLAY** repeatedly to select several pages at one time.
- The selected image will be underlined in green.
- You can delete images underlined in red.

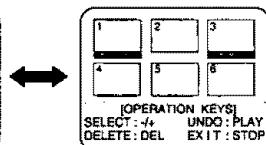
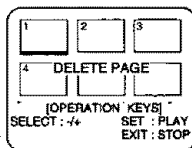

Note:

- Pictures captured with other brand products cannot be used with this Camcorder.
- If "CF CARD ERROR" appears on-screen, see page 80.

WARNING:

Do not, under any circumstances, remove the card immediately after pressing the RECORD/PAUSE (during recording of an image) or while deleting. This could damage the format of the card and make it unusable.

3 Press **DEL(STILL)**. This message appears.

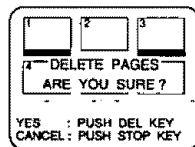

4 Press **DEL(STILL)** to delete the page.

- As image pages are deleted, page numbers adjust automatically.

Digital Still Camera

Deleting All Image Pages

All image pages are deleted from memory.

Important:

Once deleted, images cannot be restored.

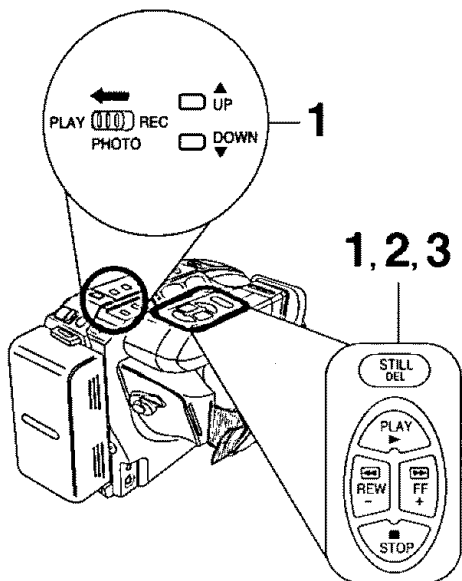

Before you begin...

- Connect Camcorder to power source.
- Insert the CompactFlash Card (page 49).
- Set POWER to PHOTO.
Slide PHOTO MODE to PLAY.

- 1** Press **DEL(STILL)** for **DELETE** menu. Press **UP ▲** or **DOWN ▼** to select **ALL**.

• To exit menu at any time, press **STOP**.

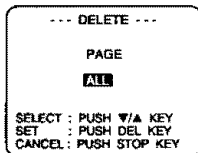

- 2** Press **DEL(STILL)**. This message appears.

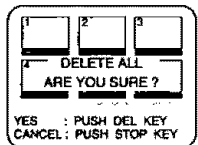

- 3** Press **DEL(STILL)** to delete all pages.
- "NO PICTURE" appears on-screen after deletion.

Note:

- Pictures captured with other brand products cannot be used with this Camcorder.
- If "CF CARD ERROR" appears on-screen, see page 80.

WARNING:

Do not, under any circumstances, remove the card immediately after pressing the RECORD/PAUSE (during recording of an image) or while deleting. This could damage the format of the card and make it unusable.

Digital Still Camera

Picture in Picture Wipe Title

Captured still images (pages 50, 51) can be recorded along with the current picture.

Before you begin...

- Connect Camcorder to power source.
- Insert the CompactFlash Card (page 49).
- Set POWER to CAMERA.

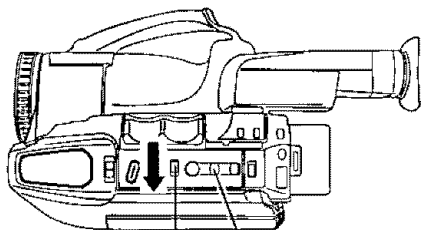

1 MODE

Still image

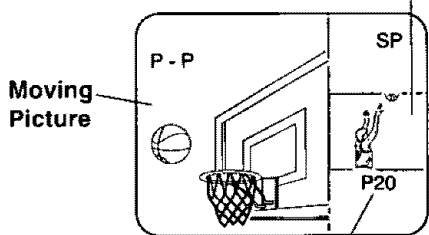

Multi image playback page number

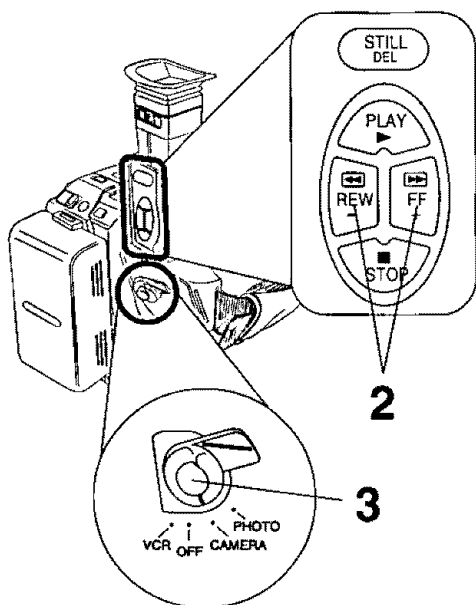

(P - P = Picture in Picture)

1

Set **DIGITAL SELECT** to **DIGITAL WIPE**.

- A still image captured on the CF card and the Multi image playback page number is displayed on the right side of the screen.
- If there are no recordings on the card, "NO PICTURE" appears on-screen.

2

Press **+** (FF) or **-** (REW) to select still image to be used.

3

Start recording (page 23).

- When recording starts, Multi image playback number disappears. Then the capture still images can be recorded along with the current picture.
- To exit from the Picture in Picture Wipe title mode, **press MODE** (page 58).

Note:

- If CompactFlash Card is not inserted, "NO CF CARD" appears on-screen. Set Power to OFF, then insert the CompactFlash Card.
- Pictures captured with other brand products cannot be used with this Camcorder.
- If "INCOMPATIBLE IMAGE" appears on-screen, the size of the captured image cannot be played back on this Camcorder.
- If "CF CARD ERROR" appears on-screen, see page 80.
- If Picture in Picture Wipe Title selected, the following functions are not available: Security mode, Auto Fade, Digital Fade, Digital Filter, Digital Zoom, Digital E.I.S., Still/Strobe/Wide.

Special Features

Digital Still Camera

Digital Wipe Mode

Insert a Captured still image into the current recording, or vice versa, in one of three wipe effects.

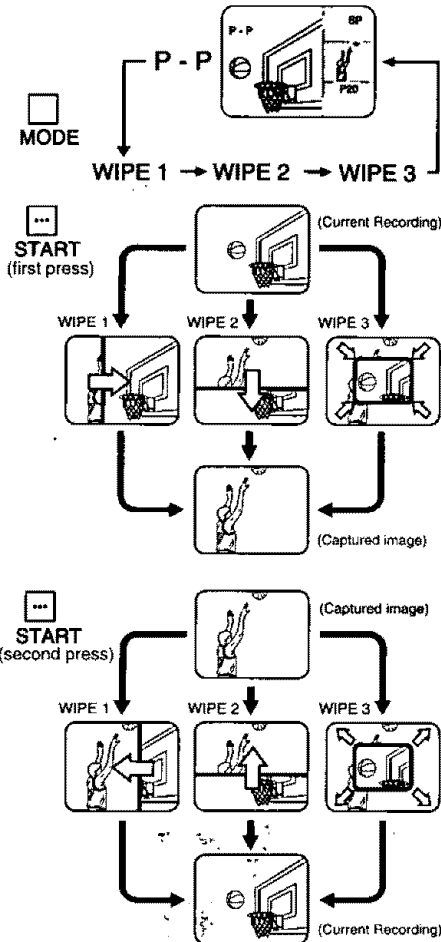
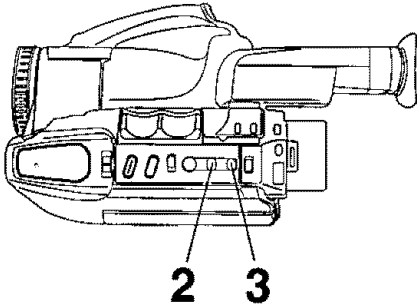

Before you begin...

- Connect Camcorder to power source.
- Insert the CompactFlash Card (page 49).
- Set **POWER** to **CAMERA**.

1 Repeat step 1 and 2 on page 57 to set Picture in Picture Wipe title.

2 Press **MODE** repeatedly for Wipe effect 1, 2, or 3 (See left).
• **WIPE 1** will flash for a while to store the image for the wipe.

3 Press **START**:
once → inserts captured image.
twice → inserts current recording picture.
• You can freeze the wipe in progress by pressing **START**. Press **START** again to resume wipe.

Note:

- If CompactFlash Card is not inserted, "NO CF CARD" appears on-screen. Set Power to OFF, then insert the CompactFlash Card.
- Pictures captured with other brand products cannot be used with this Camcorder.
- If "INCOMPATIBLE IMAGE" appears on-screen, the size of the captured image cannot be played back on this Camcorder.
- If "CF CARD ERROR" appears on-screen, see page 80.
- If Digital Wipe mode is selected, the following functions are not available: Security mode, Auto Fade, Digital Fade, Digital Filter, Digital Zoom, Digital E.I.S., Still/Strobe/Wide.

Digital Still Camera

PhotoShot Title Library

The included 8 MB CompactFlash Card already contains 12 pre-recorded titles. You can insert any one of the 12 included pre-recorded titles into your current video recording by following the steps outlined below.

CAUTION:

If you delete the following pre-recorded titles, they will not be restored.

Before you begin...

- Connect Camcorder to power source.
- Insert the CompactFlash Card (page 49).
- Set POWER to CAMERA.

- 1 Set DIGITAL SELECT to DIGITAL WIPE.
- 2 Press + (FF) or - (REW) to select still image to be used.
Please see page 57 for further details.
- 3 Start recording (page 23).



Panasonic



Anniversary



Happy Birthday



Bon Voyage



Congratulations

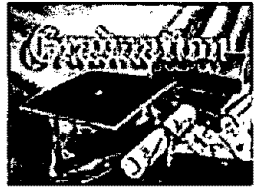

Graduation



It's a Girl!



It's a Boy!



Our Wedding

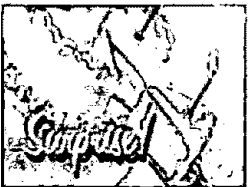

Surprise!



The Wedding



Vacation!

Special Features

PC Connection

Digital PhotoShot Software

A live or captured image can be transferred to your PC (Personal Computer).

System Requirements for Digital PhotoShot

- IBM PC/AT or compatible.
- Intel® Pentium® Processor
- Microsoft® Windows®95 or Windows®98.
- RAM: 16 MB or more
- 2 MB of available hard-disk space.
- 256 color monitor (full color recommended).
- 3.5 inch 1.44 MB floppy disk drive (for installation).
- RS-232C serial port (D-Sub 9-pin). An adaptor (D-Sub 9-pin male to a D-Sub female) is required for a D-Sub 25-pin.
- Mouse or other pointing device.

PC Camcorder Connection

Connect Camcorder PC jack to the serial port on your PC (Personal Computer) using the supplied PC connector cable. Refer to PC or Windows manual to identify which COM port to be used for connection.

Before you begin...

- Turn your PC off.
- Set Camcorder POWER to OFF.

Note:

- Be sure to turn PC off before connection for properly image transfer.
- After Camcorder and PC are connected by starting up the software included, video recording is not possible.

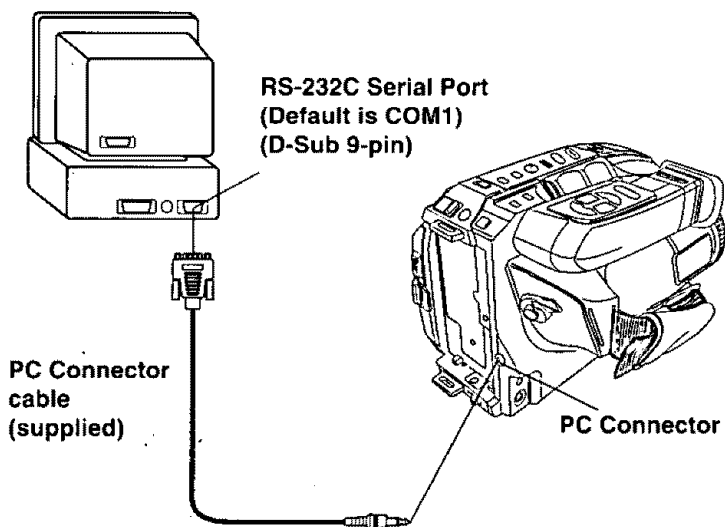

Software Installation (Windows 95/98)

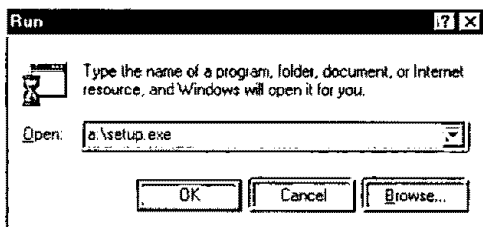
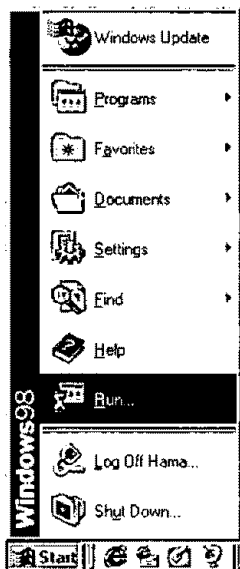

Before you begin...

- Your PC is in the power on mode.

- 1** Turn on PC (Personal Computer) and start up Windows.
- 2** Insert Digital PhotoShot disk (Windows 95/98) into a floppy disk drive.
- 3** Click on Start, then "Run..."
- 4** Type in a:\setup.exe and click OK.
 - If your 3.5 inch floppy disk drive is not "A", use appropriate letter.
- 5** Follow instructions as they appear on PC screen until the installation is complete.
 - Setup window will disappear when the installation is complete.

Note:

- Please look for Windows NT version of driver software on our website at <http://www.panasonic.com/video>.

PC Connection

Running the Software (Windows 95/98)

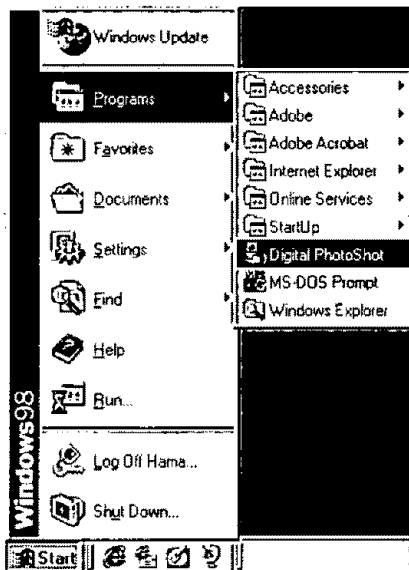

Before you begin...

- Insert the CompactFlash Card (page 49).
- Make Camcorder-PC connections (page 60).
- Turn your PC on.
- Set Camcorder POWER to PHOTO.

1 Click on Start, then "Programs," then "Digital PhotoShot."

2 "Digital PhotoShot" is opened.

Note:

- COM Port and Baudrate are automatically selected.

Refer to Help for information about application operation and other Error messages.

Using Live Image Data

You can capture the current Camcorder picture to your PC.

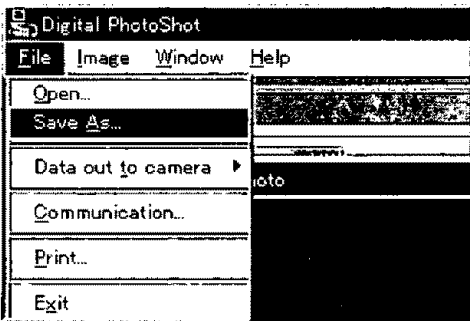
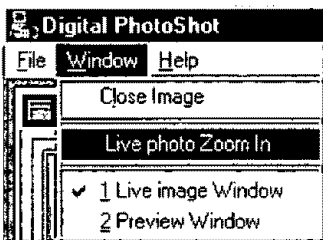
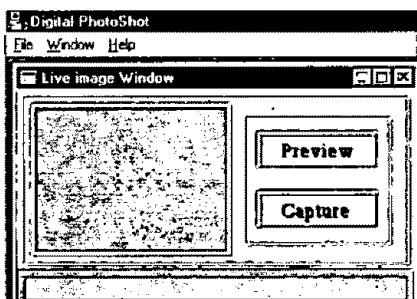
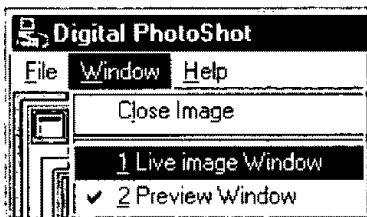

Before you begin...

- Insert the CompactFlash Card (page 49).
- Make Camcorder-PC connections (page 60).
- Turn your PC on.
- Set Camcorder POWER to PHOTO.

- 1** Repeat step 1 and 2 on page 62 to run the Software.
- 2** Click on "Window," then select "1 Live image Window."
- 3** Click on "Preview," then Click on "Capture."
 - Repeat this step to decide on an image.
 - Captured image is transferred to your PC when "Capture" is clicked on.
- 4** Click on "Window," then select "Live photo Zoom In."
- 5** Click on "File," then select "Save As."
 - Captured image is stored to your PC.

Note:

- If, while transferring the image to your PC, the displayed picture appears abnormal, restart the PC application and turn Camcorder POWER off, and then back on.

PC Connection

Using CF Card Image Data

Pictures captured with Camcorder can be transferred to your PC.

Before you begin...

- Insert the CompactFlash Card (page 49).
- Make Camcorder-PC connections (page 60).
- Turn your PC on.
- Set Camcorder POWER to PHOTO..

1

Repeat step 1 and 2 on page 62 to run the Software.

2

“Preview Window” screen appears.



3

Select the image data you want to transfer to your PC.

- The selected image will be underlined in green.

4

Click on:

Transfer

- The picture image is transferred to your PC and displayed.

Delete

- The picture image is deleted.

Save...

- The picture image is transferred to your PC and displayed. Save window appears.

Note:

- If, while transferring the image to your PC, the displayed picture appears abnormal, restart the PC application and turn Camcorder POWER off, and then back on.

Using PC Image Data

You can use JPEG or Bitmap files from your PC for Picture in Picture Wipe Title and Digital Wipe by transferring them to the Camcorder using the Digital PhotoShot Software.

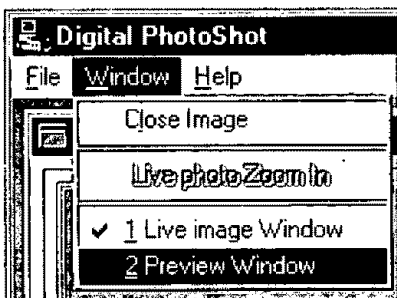

Before you begin...

- Insert the CompactFlash Card (page 49).
- Make Camcorder-PC connections (page 60).
- Turn your PC on.
- Set Camcorder POWER to PHOTO.

1 Repeat step 1 and 2 on page 62 to run the Software.

2 Click on "Window," then select "2 Preview Window."

3 Click on "File," then Click on "Open."

- At your PC, please select and open the data you want to transfer to the Camcorder.

Note:

- When transferring image data larger than VGA size (640x480) from the PC to the Camcorder, the perimeter of the image is cropped to VGA size.

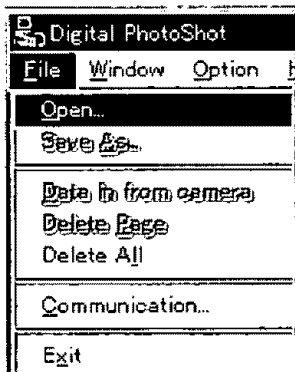

4 Click on "File," then select "Data out to camera," then select Fine or Normal mode.

- Your PC image data is transferred to the Camcorder.

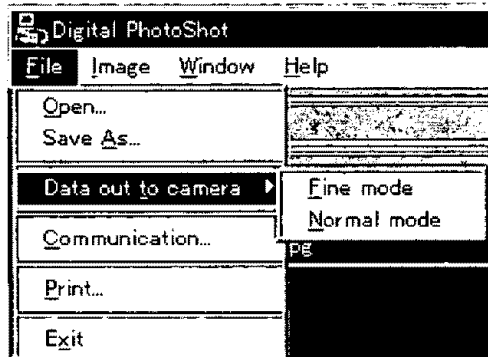

PC Connection

Driver Quick Reference

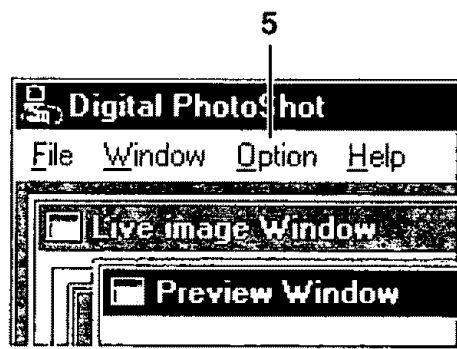
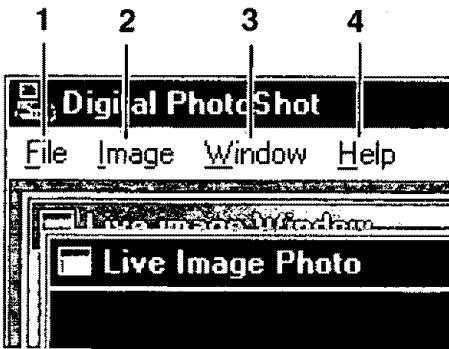

1 File

- **Open...**
To open an existing image (Bitmap or JPEG).
- **Save As**
To save the active image file under a new file name while preserving the original file.
- **Data in from CAMERA**
To display a dialog box listing all images in the CF Card memory along with Preview, Transfer, Delete, etc. commands.
- **Delete Page**
To delete the selected image from the CF Card memory.
- **Delete All**
To delete all images from the CF Card memory.
- **Communication**
To specify the port to which the Camcorder is connected.
- **Print...**
To print the currently active image.
- **Exit**
To quit the "Digital PhotoShot" application.

2 Image

- **Image Adjustment**
To modify the captured image as desired.
- **Copy to Clipboard**
To copy a view image to clipboard.

3 Window

- **Close Image**
Select "Close image" to close all view windows.
- **Live Photo Zoom In**
To open a view window.

4 Help

- **Help**
To display the Help screen.
- **About**
To display software version information.

5 Option

- **Reload**
To load the picture from the Camcorder to your PC again when Camcorder CF Card was changed.

Using a PCMCIA Adaptor (optional)

If your PC has a PCMCIA type II slot, you can insert the CompactFlash Card into a PCMCIA adaptor (optional, page 76) to transfer images, captured with this Camcorder only, to your PC.

Inserting a CompactFlash Card

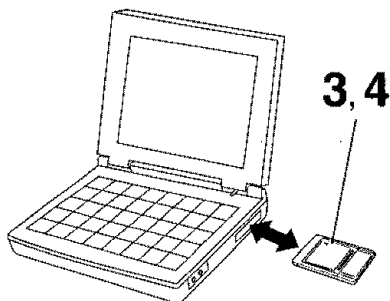
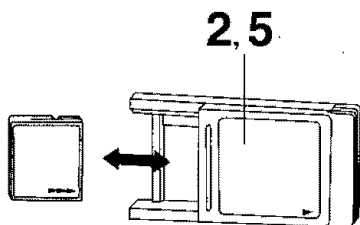
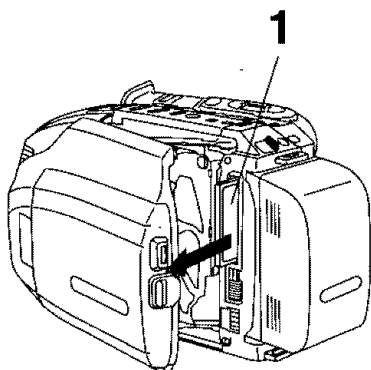

Before you begin...

- Turn your PC on.
- Set Camcorder POWER to OFF.

- 1** Remove the **CompactFlash Card** from the Camcorder (page 49).
- 2** Hold the **CompactFlash Card** so that the arrow side faces up and points toward the **PCMCIA Adaptor**. Securely insert the card into the PCMCIA Adaptor slot as far as it will go.
- 3** Hold the **PCMCIA Adaptor** so that the arrow side points toward the PCMCIA type II slot of **your PC (Personal Computer)**. Securely insert the PCMCIA Adaptor as far as it will go.
 - Depending on the PC, it may be necessary to turn the PCMCIA Adaptor upside down in order to insert the card.
- 4** To remove, push the eject button on your PC (may vary by machine) and pull the **PCMCIA Adaptor** out until it is no longer inserted in the **PC (Personal Computer)**.
- 5** Pull the **CompactFlash Card** out of the **PCMCIA Adaptor**.

Note:

- Do not remove the PCMCIA Adaptor from the PC while the PC is working or while image data is being transferred between the CompactFlash Card and the PC (including operation such as opening and storing images), this will cause irreversible damage to the memory.
- If you change file name or folder in the CF card, the images will be displayed properly on PHOTO mode.

Viewfinder/LCD Monitor Indications

Tape remaining and battery charge level can be displayed.

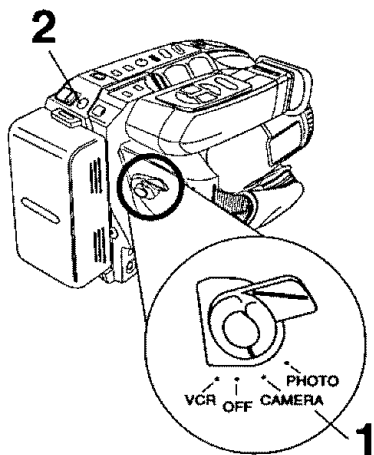

- 1 Set **POWER** to **CAMERA**.
- 2 Press **DISPLAY** repeatedly to select the following displays.

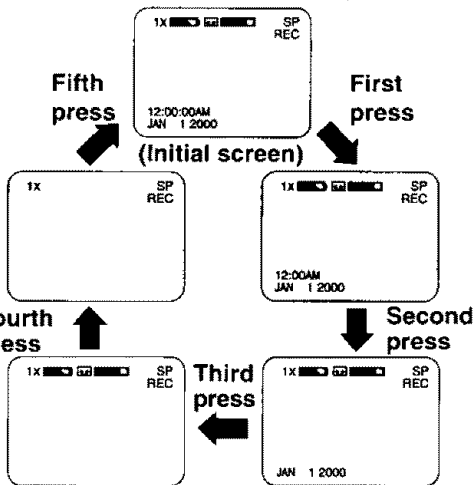
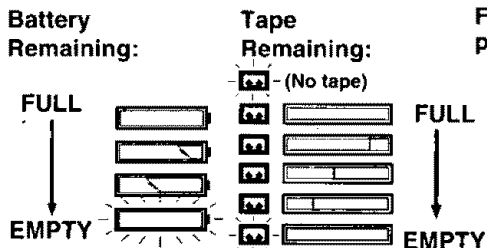

• Tape remaining indicator operates a few seconds after tape starts moving.

Recording the Date and Time

- 1 Do steps 1 and 2 above to select time/date, date only, or no display.
- 2 Start a recording (page 23).
 • Only the Date and/or Time are recorded.

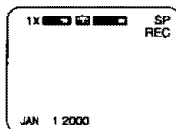
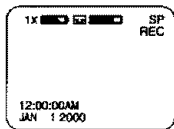

Display-Off Mode

No Indication, except Intelligent Titler (pages 46-48), will be displayed.

- 1 Press **MENU** for **MENU** mode.
 Press **UP ▲** or **DOWN ▼** to select **DISPLAY**.
- 2 Press **DISPLAY** to select **OFF**.
 Press **MENU** to exit.
- 3 Press **DISPLAY** repeatedly to remove time/date.

Indications are restored when Camcorder is turned off, and then on again.

Before you begin...

- Connect Camcorder to power source.
- Set **POWER** to **CAMERA** or **VCR**.

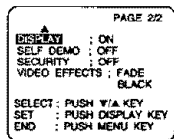

CAMERA MODE

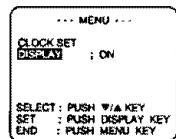

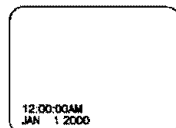

VCR MODE



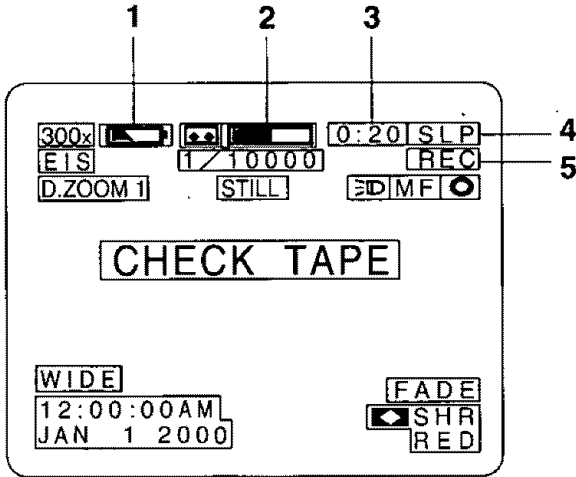

Viewfinder/LCD Monitor Indications

CAMERA/VCR mode



1 Battery Remaining  (page 68)
 "WARNING LOW BATTERY" appears and Power Lamp starts flashing 15 seconds before Camcorder shutoff.

2 Tape Remaining

- If **RECORD/PAUSE** is pressed with no cassette, or cassette has no record tab in Camera (RECORD) mode, "" flashes 1 minute and "CHECK TAPE" appears 5 seconds.
- If **PLAY, FF** or **REW** is pressed with no cassette inserted in VCR mode, "" flashes 1 minute and "CHECK TAPE" appears 5 seconds.
- As end of tape is reached, "" flashes and "TAPE END" appears 5 seconds.

3 10-Second Reminder
 Each time a recording is started, a 10 second incremental display (up to 59:50) lets you monitor how long one scene is recorded.

0:00 0:10 0:20 59:50



(return to 0:00 and continue)

4 TAPE SPEED (pages 15, 23)
 (SP=standard play, SLP=super long play).

5 Operating Mode
REC (record)
PAUSE
FF (fast forward)
PLAY
REW (rewind)

Viewfinder/LCD Monitor Indications

CAMERA/VCR mode

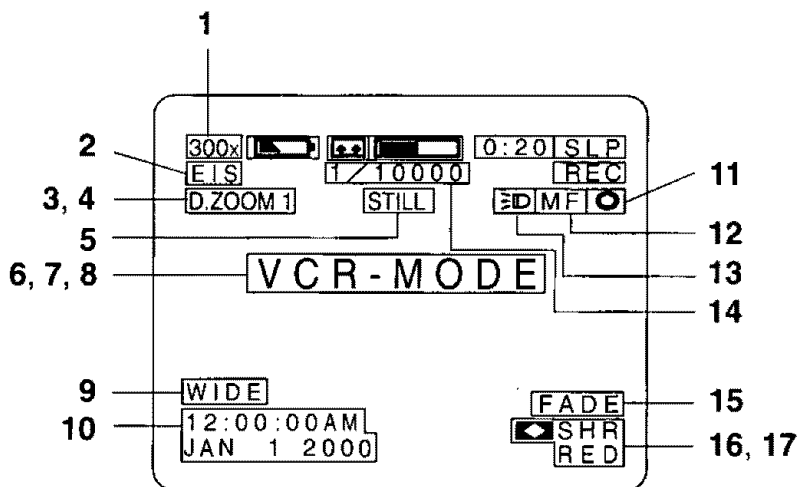

- | | |
|--|--|
| 1 Zoom Magnification level (page 34). | 11 Backlight (page 34). |
| 2 Digital E.I.S. (page 43). | 12 Manual Focus (page 35). |
| 3 Digital Zoom (page 42). | 13 Light ON/OFF (pages 22, 52). |
| 4 Digital Wipe (pages 57, 58). | 14 High Speed Shutter (page 36). |
| 5 Still/Strobe (page 44). | 15 Fade (page 39). |
| 6 VCR-MODE
Appears 1 minute when POWER is set to VCR or if <u>RECORD/PAUSE</u> is pressed in VCR mode. | 16 Color Digital Fade (pages 40, 41). |
| 7 DEW
If moisture condensation occurs in unit, "WARNING DEW DETECTED" appears, Power Lamp flashes, and Camcorder will shutoff in 15 seconds. Wait until lamp no longer flashes when Camcorder is turned on to use. | 17 Color Digital Filter (page 38). |
| 8 Security Mode (pages 45). | |
| 9 Wide Screen (page 44). | |
| 10 Date and Time (page 21). | |

Viewfinder/LCD Monitor Indications

PHOTO mode

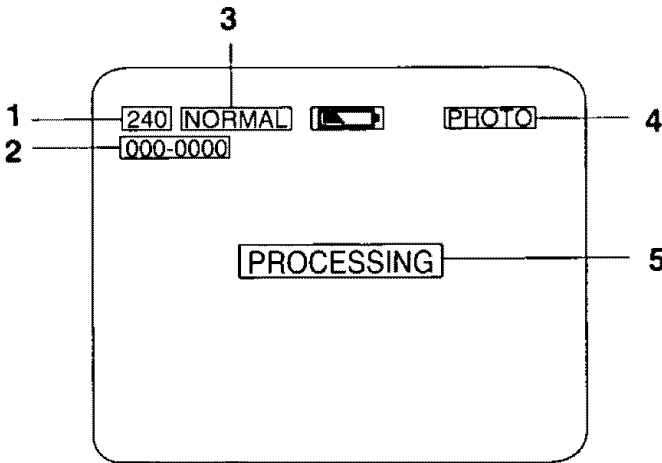

1 Image Page Remaining Indication

(pages 50, 51)

- Image pages left in selected mode.
"000" flashes when memory is full.
- Memory capacity provided all pictures are taken in the same mode:
"NORMAL" mode → Approx 240 images
(Supplied 8 MB CompactFlash Card)
"FINE" mode → Approx 60 images
(Supplied 8 MB CompactFlash Card)

2 Directory/Image Number (page 54)

3 REC MODE

- NORMAL or FINE mode.
- Image Size :
"NORMAL" mode → 320 x 240 pixels.
"FINE" mode → 640 x 480 pixels.

4 Recording Mode

- POWER is set to PHOTO.

5 Image Status Indication

Image status is displayed when captured.

PROCESSING:

Image is being processed.
Note: Do not change setting to CAMERA or change recording mode while "PROCESSING" is displayed.

COMPLETED:

Image processing is completed.
The next image may be captured when "COMPLETED" disappears.

PLEASE WAIT:

Displayed when image is selected from Multi Image Playback screen.
Note: Do not change POWER setting to CAMERA or change recording mode while "PLEASE WAIT" is displayed.

Viewfinder/LCD Monitor Indications

PHOTO mode

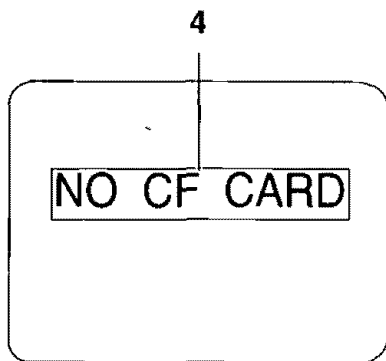
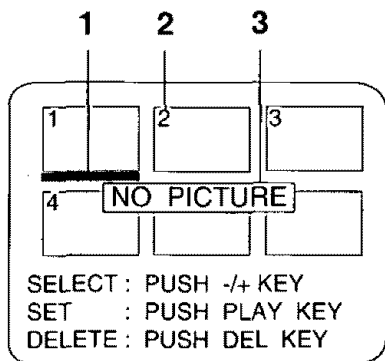

- 1** Currently selected image is underlined in green or red.
- 2** Multi Image Playback page number.
"NORMAL" mode → green
"FINE" mode → white
- 3** Image Status Indication
NO PICTURE:
No image is captured, all images are deleted from card.

- 4** **CF CARD Indication**
When the CompactFlash Card is not inserted in CAMERA or PHOTO mode, "NO CF CARD" appears.
If the CompactFlash Card is defective, "CF CARD ERROR" appears.

Operation Notes

Attaching Optional Filters and Lenses

When you remove the Lens Hood, pinch the Lens Hood and turn it counterclockwise as illustrated at right.

Then attach an optional filter or lens.

- Be careful not to touch the lens itself.
- Replace the Lens Hood after removing the accessory.

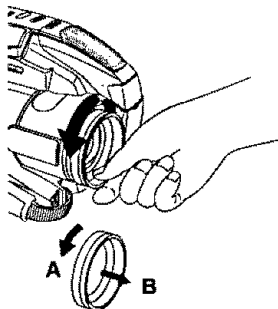

Lens Hood Area Operation Caution

With a Wide or Telephoto conversion lens (optional) attached, the four corners of the screen may darken when zoom is set to maximum wide angle.

When attaching the lens hood, a Wide or Telephoto conversion lens (optional), etc. after a filter (optional) has been attached, the four corners of the screen may darken when zoom is set to maximum wide angle.

With two filters (optional) attached, the four corners of the screen may darken when zoom is set to maximum wide angle.

Cleaning EVF (Electronic Viewfinder)

To Remove

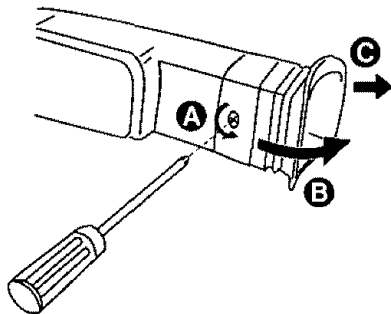

- 1** **A** Remove the screw with a Phillips screwdriver.
Turn counterclockwise.
B Turn the EVF Eyepiece.
C Pull the EVF Eyepiece.
- 2** Remove any lint or dust particles with a soft clean cloth being careful not to scratch the glass surfaces.
- 3** Replace the EVF Eyepiece and the screw.

For Your Information

Replacing Clock/ Remote Battery

The clock and remote batteries are pre-installed. Follow the steps below if replacement becomes necessary.

WARNING:

Replace battery with Panasonic PART NO. VSBW0004 (CR2025) only. Use of another battery may present a risk of fire or explosion.

Caution: Battery may explode if mistreated. Dispose of used battery promptly. Keep away from children. Do not recharge, disassemble or dispose of in fire.

Clock Battery

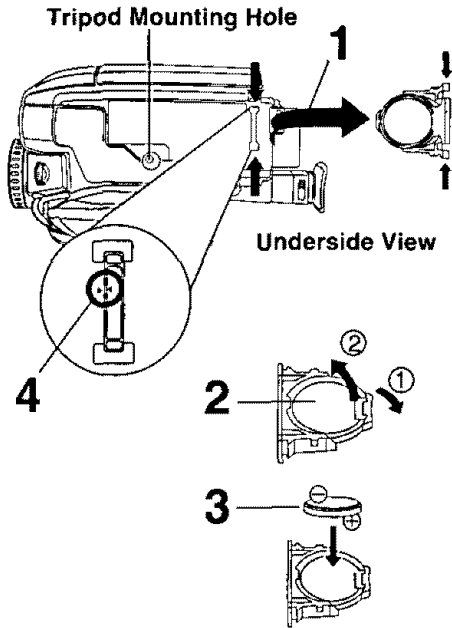

- 1 While pinching 2 tabs, pull Battery Tray out.
- 2 Bend 1 tab to remove Battery.
- 3 Snap new Battery (⊕ mark down) into Battery Tray.
 - Do not reverse the polarity.
- 4 Insert Battery Tray so the triangle marks meet.

Note:

- Keep Battery out of children's reach. Swallowing it may be harmful.
- Improperly installed, discharged, or missing battery causes "CLOCK BATTERY" to appear when DISPLAY is pressed.
- Battery life is approximately 5 years.

Remote Battery

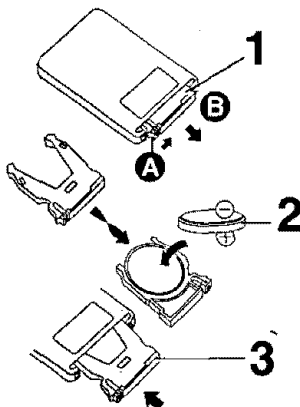

- 1 **A** While pressing stopper tab, **B** pull Battery Tray out.
- 2 Insert battery into tray with ⊕ mark down.
Do not reverse polarity.
- 3 Replace Battery Tray.

Palmcorder Accessory System

For ordering instructions, see the Accessory Order Form page.



- The listed standard battery use times are based on continuous recording using this Palmcorder.

Accessory #	Figure	Description	Price
PV-A17		AC Adaptor with DC Power Cable	\$130.00
HHR-V214A/K		6.0Ah / 6 hr Battery Pack with Universal Battery Charger	\$200.00
P-V215A/1B		3.0Ah / 3 hr Battery Pack	\$60.00
PV-BP17, P-V214A/1B		2.4Ah / 2 hr 30 min Battery Pack	\$50.00
PV-BP18, P-V611A/1B		1.8Ah / 2 hr Battery Pack	\$45.00
PV-BP15, P-V213A/1B		1.2Ah / 1 hr 10 min Battery Pack	\$45.00
PV-AA6		"AA" Battery Case	\$20.00

For Your Information

Palmcorder Accessory System

For ordering instructions, see the Accessory Order Form page.

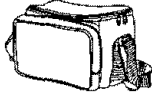
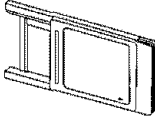
Accessory #	Figure	Description	Price
PV-C16		Car Battery Cord	\$70.00
PV-RF16		RF Adaptor	\$40.00
PV-P1		VHS PlayPak	\$35.00
PV-H18A		Soft Sided Carrying Case	\$49.00
KXL-D55		PCMCIA Adaptor	\$39.00

Palmcorder Accessory Order Form

Please photocopy this form when placing an order.

1. Palmcorder Model # _____

2. Items Ordered

Accessory #	Description	Price Each	Quantity	Total Price
Subtotal				
Your State & Local Sales Tax				
Shipping & Handling				5.00
Total Enclosed				

3. Method of payment (check one)

- Check or Money Order enclosed (NO C.O.D. SHIPMENTS)
- VISA Credit Card # _____
- MasterCard Expiration Date _____
- Discover Customer Signature _____

Make Check or Money Order to: MATSUSHITA ACCESSORIES

(Please do not send cash)

4. Shipping information (UPS delivery requires complete street address)

Ship To:

Mr. _____
 Mrs. _____
 Ms. _____

First _____ Last _____

Phone #:

Day () _____

Street Address _____

Night () _____

City _____ State _____ Zip _____

TO OBTAIN ANY OF OUR OMNIMOVIE/PALMCORDER ACCESSORIES YOU CAN DO ANY OF THE FOLLOWING:

VISIT YOUR LOCAL PANASONIC DEALER

OR

CALL PANASONIC'S ACCESSORY ORDER LINE AT 1-800-332-5368

[6 AM-5 PM M-F, 6 AM-10:30 AM SAT, PACIFIC TIME]

OR

MAIL THIS ORDER TO: PANASONIC SERVICES COMPANY ACCESSORY ORDER OFFICE

20421 84th Avenue South Kent, WA. 98032

For Your Information

Specifications

Power Source:	Compact VHS Camcorder: DC 6 V AC Adaptor: 110/120/220/240 V AC, 50/60 Hz Battery: Nickel-Cadmium Type DC 6 V
Power Consumption:	Compact VHS Camcorder: 6 V DC 8.5 W (Max. 11.5 W) AC Adaptor: 24 W 1.2 W (when not in use.)
Video Signal:	EIA Standard (525 lines, 60 fields) NTSC color signal
Video Recording System:	2 rotary heads plus flying erase head. Helical scanning system
Audio:	1 track
Pick-Up System:	Sequential color difference field reverse system
Pick-Up Device:	One integral color filter Charge Coupled Device (CCD)
Lens:	26:1 zoom lens, F1:1.6 with auto iris control Focal length: 3.8 mm - 98.8 mm 4 speed power zoom function Lens filter diameter: 49 mm
Viewfinder:	10.2 mm (0.4 inch) Electronic Viewfinder
LCD Monitor:	101.6 mm (4.0 inch) Liquid Crystal Display
Memory:	8 MB CompactFlash Card
Image Size:	FINE: 640 × 480 pixels Normal: 320 × 240 pixels
Image Storage:	FINE: Approx. 60 images Normal: Approx. 240 images
Image Format:	JPEG
Minimum Illumination Required:	0.8 lx (F1:1.6) 0.08 footcandles 7 lx (F1:1.6) 0.7 footcandles (EIA Standard)
Earphone Jack:	M3 Type
Operating Temperature:	0 °C~40 °C (32 °F~104 °F)
Operating Humidity:	10 %~75 %
Weight:	Compact VHS Camcorder: 1.09 kg 2.4 lbs. AC Adaptor: 0.35 kg 0.77 lbs.
Dimensions:	Compact VHS Camcorder: 107 (W) × 118 (H) × 180 (D) mm 4-1/4 (W) × 4-5/8 (H) × 7-1/8 (D) inch AC Adaptor: 70 (W) × 41 (H) × 145 (D) mm 2-3/4 (W) × 1-5/8 (H) × 5-3/4 (D) inch

Weight and dimensions shown are approximate.

Designs and specifications are subject to change without notice.

Before Requesting Service

If a problem arises, you may be able to correct it yourself.

See Symptom and Correction list below.

Symptom	Correction
No picture in EVF or LCD monitor ...	<ul style="list-style-type: none"> • Connect Power Source. (pp. 12, 14) • Set POWER to VCR or CAMERA. (pp. 23, 29) • Check for Dew Indication. (p. 70) • Use fully charged Battery. (p. 12) • Firmly connect all needed cables. (p. 31)
The right side of the screen appears grayish...	<ul style="list-style-type: none"> • Be sure to slide Digital Select to Digital Wipe. (p. 58)
Video cassette cannot be inserted ...	<ul style="list-style-type: none"> • Connect Power Source. (pp. 12, 14) • Insert cassette, window side facing out. (p. 15)
Video cassette cannot be removed ...	<ul style="list-style-type: none"> • Connect Power Source. (pp. 12, 14)
Operation buttons do not work ...	<ul style="list-style-type: none"> • Check for Dew Indication. (p. 70)
Recording cannot be done ...	<ul style="list-style-type: none"> • Make sure record tab is intact. (p. 15) • Check Battery Indicator. (p. 68) • Check for Dew Indication. (p. 70)
Auto Focus does not operate ...	<ul style="list-style-type: none"> • Set FOCUS to AUTO. (p. 35) • Set POWER to CAMERA. (p. 23)
Sound from microphone can't be monitored ...	<ul style="list-style-type: none"> • Set unit to REC or Record/Pause mode.
Camera picture is too dark ...	<ul style="list-style-type: none"> • Turn HIGH SPEED SHUTTER off. (p. 36)
No playback picture, or the playback picture is noisy or contains streaks ...	<ul style="list-style-type: none"> • Press UP ▲/DOWN ▼ button during playback (Tracking Control). (p.30)
"Panasonic ITS TAPES PLAY IN YOUR VCR ..." appears in EVF or LCD Monitor ...	<ul style="list-style-type: none"> • Set POWER to CAMERA, then set SELF DEMO : OFF in MENU screen to cancel Demo mode. (p. 8)
"NO CF CARD" appears in EVF or LCD Monitor ...	<ul style="list-style-type: none"> • Make sure CompactFlash Card is inserted. (p. 49)
Cannot capture the image ...	<ul style="list-style-type: none"> • Set POWER to PHOTO. (p. 50) • No memory remaining. Delete some images before capturing more images.
Cannot playback Still image ...	<ul style="list-style-type: none"> • Set POWER to PHOTO. (p. 53) • Make sure CompactFlash Card is inserted. (p. 49)
"NO PICTURE" appears in EVF or LCD Monitor ...	<ul style="list-style-type: none"> • There are no images in memory.
Top of playback picture waves back and forth excessively ...	<ul style="list-style-type: none"> • A playback signal is not as stable as an off the air TV signal, so the top of your TV screen may appear bent or unstable during playback. This is called, "Horizontal AFC time constant change." To correct, slowly turn the TV horizontal hold control. If you TV does not have this control, or adjusting it does not help, contact your TV service center. (Some nominal service charges may be required.)

For Your Information

Before Requesting Service

Video Head Cleaning



Clogged Video Head

While head cleaning is normally not needed, playing old or damaged tapes may clog the heads. When playback picture resembles example at the left, head cleaning is required.

Ideally, head cleaning should be performed by a qualified service technician. When this is not possible, purchase a head cleaning cassette. Be sure to follow cleaning cassette instructions exactly and only use when symptoms occur.

Self Diagnostic System

If any of the following numbers appear on-screen, the camcorder may have a problem. Do not remove the battery (if attached) and write down the displayed number on page 81. Then, take the camcorder to a service center for repair.

Error No.	Description
U11	CF Card Error
U12	CF Card Error
U13	CF Card Error
U14	CF Card/Camcorder Dialogue Error
U15	No CF Card Memory
U16	Captured image limit exceeded
U17	Captured image limit exceeded
U30	Error other than above

Request for Service Notice

Please photocopy this form when making a request for service notice.

Request for Service Notice:

In the unlikely event this product needs service.

- Please include your **proof of purchase**.
(Failure to do so will delay your repair.)
- To further speed your repair please provide an explanation of what is wrong with the unit and any symptom it is exhibiting.

Mail this completed form and your Proof of Purchase along with your unit to:
Panasonic Services Company
1705 N. Randall Road
Elgin, IL. 60123-7847
Attn: Camcorder Repair

Please write the displayed Self Diagnostic number here.
(See page 80)

For Your Information

Warranty

Panasonic Consumer Electronics Company, Division of Matsushita Electric Corporation of America
One Panasonic Way Secaucus, New Jersey 07094

Panasonic Sales Company, Division of Matsushita Electric of Puerto Rico, Inc.
Ave. 65 de Infantería, Km. 9.5
San Gabriel Industrial Park, Carolina, Puerto Rico 00985

PANASONIC/QUASAR Video Products Limited Warranty

Panasonic Consumer Electronics Company or Panasonic Sales Company (collectively referred to as "the Warrantor") will repair this product with new or refurbished parts, free of charge, in the USA or Puerto Rico, in the event of a defect in materials or workmanship as follows (all time periods commence from the date of the original purchase):

PRODUCT	PARTS	LABOR
CAMCORDER	ONE (1) YEAR, EXCEPT CCD IMAGE SENSOR CCD IMAGE SENSOR - SIX (6) MONTHS	NINETY (90) DAYS NINETY (90) DAYS
VCR	ONE (1) YEAR	NINETY (90) DAYS
A/V MIXER	ONE (1) YEAR	NINETY (90) DAYS
MONITOR-VCR	ONE (1) YEAR, EXCEPT CRT CRT - TWO (2) YEARS	NINETY (90) DAYS CRT - NINETY (90) DAYS CUSTOMER PAYS ALL LABOR CHARGES AFTER 90 DAYS

Monitor-VCR In-home or carry-in Service: 22" (diagonal) CRT / LCD and Larger Monitor-VCR Carry-in Service: 21" (diagonal) CRT / LCD and smaller

Batteries (if included) - New rechargeable batteries in exchange for defective rechargeable batteries for ten (10) days. Non-rechargeable batteries are not warranted.

Tape (if included) - New video cassette tape in exchange for a defective video cassette tape for five (5) days.

In-home, carry-in or mail-in service, as applicable, in the USA can be obtained during the warranty period by contacting a Panasonic Services Company (PASC) Factory Servicenter listed in the Service Directory. Or call toll free 1-800-211-PANA(7262), to locate an authorized PASC Servicenter. Carry-in or mail-in service in Puerto Rico can be obtained during the warranty period by calling the Panasonic Sales Company telephone number listed in the Servicenter Directory.

This warranty is extended only to the original purchaser. A purchase receipt or other proof of the date of the original purchase is required before warranty service is rendered.

This warranty only covers failures due to defects in materials and workmanship which occur during normal use and does not cover normal maintenance, including, but not limited to, video and audio head cleaning. The warranty does not cover damage which occurs in shipment, or failures which are caused by products not supplied by the warrantor, or failures which result from accident, misuse, abuse, neglect, mishandling, misapplication, alteration, modification, faulty installation, set-up adjustments, improper antenna, inadequate signal pickup, maladjustment of consumer controls, improper operation, power line surge, improper voltage supply, lightning damage, commercial use such as hotel, office, restaurant, or other business or rental use of the product, or service by anyone other than a PASC Factory Servicenter or a PASC authorized Servicenter, or damage that is attributable to acts of God.

LIMITS AND EXCLUSIONS

There are no express warranties except as listed above. THE WARRANTOR SHALL NOT BE LIABLE FOR INCIDENTAL OR CONSEQUENTIAL DAMAGES (INCLUDING, WITHOUT LIMITATION, DAMAGE TO TAPES) RESULTING FROM THE USE OF THIS PRODUCTS, OR ARISING OUT OF ANY BREACH OF THE WARRANTY. ALL EXPRESS AND IMPLIED WARRANTIES, INCLUDING THE WARRANTIES OF MERCHANTABILITY AND FITNESS FOR PARTICULAR PURPOSE, ARE LIMITED TO THE APPLICABLE WARRANTY PERIOD SET FORTH ABOVE. Some states do not allow the exclusion or limitation of incidental or consequential damages, or limitations on how long an implied warranty lasts, so the above exclusions or limitations may not apply to you.

This warranty gives you specific legal rights and you may also have other rights which vary from state to state.

If a problem with this product develops during or after the warranty period, you may contact your dealer or Servicenter. If the problem is not handled to your satisfaction, then write to the Customer Satisfaction Center at the Panasonic Consumer Electronics Company address above.

SERVICE CALLS WHICH DO NOT INVOLVE DEFECTIVE MATERIALS OR WORKMANSHIP AS DETERMINED BY THE WARRANTOR, IN ITS SOLE DISCRETION, ARE NOT COVERED. COSTS OF SUCH SERVICE CALLS ARE THE RESPONSIBILITY OF THE PURCHASER.

warvid 10/20/97

Warranty

For Product Information, Operating Assistance, Literature Request, Dealer Locations, and all Customer Service inquiries please contact:

1-800-211-PANA(7262); Monday-Friday 9am-9pm Saturday-Sunday 9am-7am, EST.

Web Site: <http://www.panasonic.com>

You can purchase parts, accessories or locate your nearest servicenter by visiting our Web Site.

Accessory Purchases:

1-800-332-5368 (Customer Orders Only)

Panasonic Services Company 20421 84th Avenue South, Kent, WA 98032

(6 am to 5 pm Monday - Friday; 6 am to 10:30 am Saturday; PST)

(Visa, MasterCard, Discover Card, American Express, Check)

Product Repairs:

Centralized Factory Servicenter

MAIL TO :

Panasonic Services Company
1705 N. Randall Road,
Elgin, IL 60123-7847

Attention: Camcorder Repair

Please carefully pack and ship, prepaid and insured, to the Elgin centralized repair Factory Servicenter. While there will be added handling delays, you may bring your unit to one of the following locations who will then forward the unit to Elgin for repair.

Customer's in Puerto Rico, please ship or carry in to location below ("Service in Puerto Rico").

Factory Servicenters Locations:

CALIFORNIA

6550 Katella Avenue
Cypress, CA 90630

800 Dubuque Avenue
S. San Francisco
CA 94080

20201 Sherman Way
Suite 102
Canoga Park, CA 91306

3878 Ruffin Road
Suite A
San Diego, CA 92123

COLORADO

1640 South Abilene
Street Suite D
Aurora, CO 80012

FLORIDA

3700 North 29th Avenue
Suite 102
Hollywood, FL 33020

GEORGIA

8655 Roswell Road
Suite 100
Atlanta, GA 30350

ILLINOIS

9060 Golf Road
Niles, IL 60714

1703 North Randall Road
Elgin, IL 60123
(Pick-up/drop-off only)

MARYLAND

62 Mountain Road
Glen Burnie, MD 21061

MASSACHUSETTS

60 Glacier Drive
Suite G
Westwood, MA 02090

MICHIGAN

37048 Van Dyke Avenue
Sterling Heights,
MI 48312

MINNESOTA

7850-12th Avenue South
Airport Business Center
Bloomington, MN 55425

OHIO

2236 Waycross Road
Civic Center Plaza
ForestPark, OH 45240

PENNSYLVANIA

2221 Cabot Blvd. West
Suite B
Langhorne, PA 19047

Chartiers Valley
Shopping Center
1025 Washington Pike
Bridgeville, PA 15017

TENNESSEE

3800 Ezell Road
Suite 806
Nashville, TN 37211

TEXAS

7482 Harwin Drive
Houston, TX 77036

13615 Welch Road
Suite 101
Farmers Branch, TX
75244

WASHINGTON

20425-84th Avenue
South
Kent, WA 98032

HAWAII

99-859 Iwaiwa Street
Aiea, Hawaii 96701
Phone (808) 488-1996
Fax (808) 486-4369

Service in Puerto Rico

Matsushita Electric of Puerto Rico, Inc. Panasonic Sales Company/ Factory Servicenter:

Ave. 65 de Infanteria. Km. 9.5 San Gabriel Industrial Park Carolina, Puerto Rico 00985

Phone (787) 750-4300 Fax (787) 768-2910

For Your Information

Index

Symbols

- + (FF) Button 53, 55, 57, 59
- (REW) Button 53, 55, 57, 59

A

- AC Adaptor 14
- Accessories (Optional) 75, 76
- Accessories (Supplied) 2
- Audio/Video Cable 31, 33
- Audio/Video Out 31, 33
- Auto Daylight Saving Time 20

B

- Backlight 34
- BACKLIGHT Button 34
- Battery Pack 9, 12, 13
- BATTERY RELEASE Button 12
- BRIGHT Control 24, 29
- Built-In Twin Capsule 2-Way
Microphone System -- 23

C

- Camera Recording 23-27
- Car Battery Cord 14
- CARD EJECT Switch 49
- Charging Battery 12
- Cleaning EVF 73
- Clock Battery 74
- Clock Set 19-21
- Color Digital Filter 38
- CompactFlash Card 9, 49, 67
- Copying your Tapes 33

D

- D.ZOOM Button 42
- DC IN 14
- DC Power Cable 14
- DEL(STILL) Button 55, 56
- Digital E.I.S. 43

- DIGITAL SELECT Switch 38-40, 42-45, 57, 59

- Digital Still Camera 49-59
- Digital Wipe Mode 58

- DISPLAY Button 8, 17, 19-21, 25, 27, 30, 37-41, 45, 46, 48, 50, 54, 68
- Display-off Mode 68

E

- EIS Button 43
- Electronic Viewfinder 73

F

- Fade 39-41
- FADE Button 39, 41
- FAST FORWARD/SEARCH Button 30
- Focus 35

H

- Hand Strap 16
- High Speed Shutter 36
- HIGH SPEED SHUTTER Button 36

L

- LCD Monitor 24, 29, 50, 53
- LCD-OPEN Button 10, 11, 24, 29, 50, 53
- Lens Cover 23, 50
- Lens Hood 73
- Light 22, 52
- LIGHT Switch 22, 52

M

- MANUAL FOCUS Wheel 35
- MENU Button 8, 17, 19-21, 25, 27, 37-41, 45, 46, 48, 50, 54, 68
- MENU Mode 17, 18
- MODE Button 57, 58

P

PC Connection	60~66
PC Connector	60
PCMCIA Adaptor	67
PHONE (earphone) jack	24, 29
PHOTO MODE Selector	50, 53
PhotoShot Title Library	59
Picture in Picture Wipe Title	57
PLAY Button	11, 29, 53, 55
Playback	29~32
PlayPak	32
Power Lamp	23, 29, 50, 69
Power Supply	12~14
POWER Switch	8, 10, 11, 23, 29, 50
POWER ZOOM Switch	34, 35, 42
Programmed Recording	27

R

RECORD Button	51
RECORD/PAUSE Button	10, 23, 51
Remote Control	28
Remote Holder	16, 28
Replacing Battery	74
Request for Service Notice	81
REWIND/SEARCH Button	11, 29, 30
RF Adaptor	31

S

Safety Precautions	3
Security Mode	45
Self Demo Mode	8
Self Diagnostic System	80
Shoulder Strap	16
Speaker	29
Specifications	78
START Button	58
Still / Strobe / Wide	44
STILL Button	30
Still Picture	30
STILL/STROBE Button	44
STOP Button	11, 29

T

Tab	15
Tally Lamp	23, 37
TAPE EJECT Switch	9, 15, 49
TAPE SPEED Selector	15, 23
TITLE Button	46~48
Titler	46~48
Tracking Control	30
Tripod Mounting Hole	74

U

UP ▲/DOWN ▼ Button	8, 17, 19~21, 25, 27, 30, 37~40, 45, 46, 48, 50, 54, 55, 56, 68
--------------------	---

V

VHF Connecting Cable	31, 33
Video Cassettes (tapes)	15
Video Head Cleaning	80
Viewfinder/LCD Monitor Indications	68~72
Viewing	31
Vision Adjustment Control	23
VOLUME Control	29

W

Warranty	82, 83
----------	--------

Z

Zoom	34, 42
------	--------

Spanish Quick Use Guide/Guía Para Uso Rápido

Antes de comenzar...

- Inserte un casete con lengüeta para prevención del grabado.

Cargue la batería

Cargue completamente la batería antes de usarla.

2

Inserte la batería.
La lámpara CHARGE se
enciende y se apaga al
terminar de cargar.
Desmonte la batería.

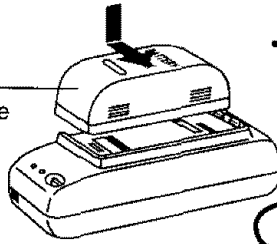

1

Enchufe el adaptador
de CA.

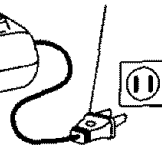

Inserción de la Tarjeta CompactFlash

Cuando no se haya insertado la Tarjeta CompactFlash en el modo CAMERA o PHOTO , en la pantalla aparecerá "NO CF CARD". Asegúrese de insertar la Tarjeta CompactFlash antes de utilizar la Cámara Fija Digital Incorporada.

La grabación CAMERA es posible incluso cuando no se ha insertado la Tarjeta CompactFlash.

2

Deslice TAPE EJECT para abrir la
compuerta.

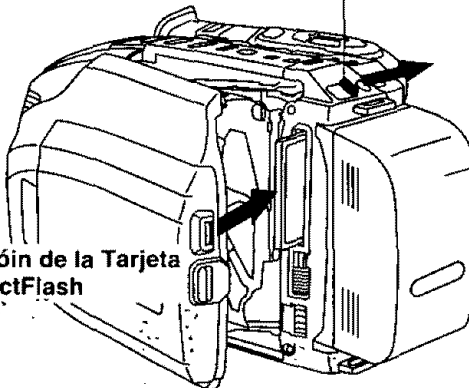

1

Coloque la batería
cargada.

3

Inserción de la Tarjeta
CompactFlash

Spanish Quick Use Guide/Guía Para Uso Rápido

Inserte el casete

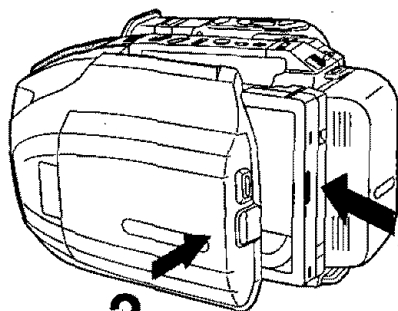

2

Presione aquí para cerrar la compuerta.

1

Inserte el casete.

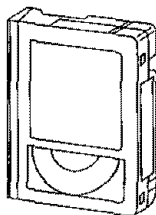

Grabación con la videocámara

Cuando el monitor LCD está completamente abierto, el visor se desconecta automáticamente.

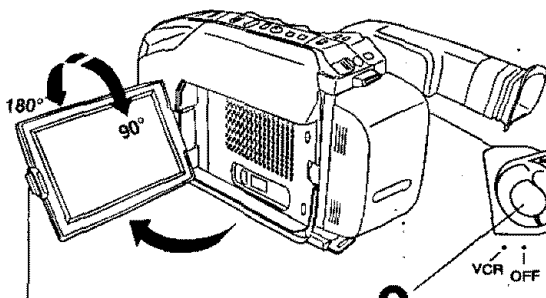

1

Presione LCD-OPEN para abrir el monitor LCD. Abralo completamente y ajuste el ángulo.

2

Ajuste POWER a CAMERA.

3

Presione RECORD/PAUSE para comenzar la grabación. Presione RECORD/PAUSE otra vez para hacer una pausa en la grabación.

For Your Information

Spanish Quick Use Guide/Guía Para Uso Rápido

Antes de comenzar...

- Conecte la fuente de alimentación de la videocámara (batería o adaptador de CA)
- Inserte un casete con lengüeta para prevención del grabado.

Reproduzca usando el monitor LCD

Cuando el monitor LCD está completamente abierto, el visor se desconecta automáticamente.

- 1** Presione LCD-OPEN para abrir el monitor LCD. Abralo completamente y ajuste el ángulo.

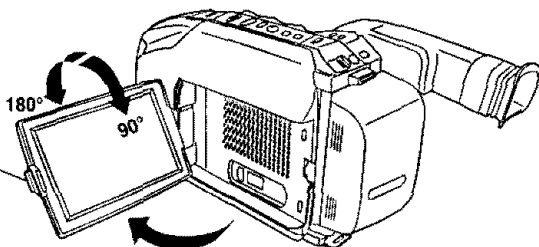

- 2** Ajuste POWER a VCR.

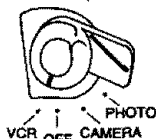

- 3** Presione REWIND/SEARCH para rebobinar la cinta.

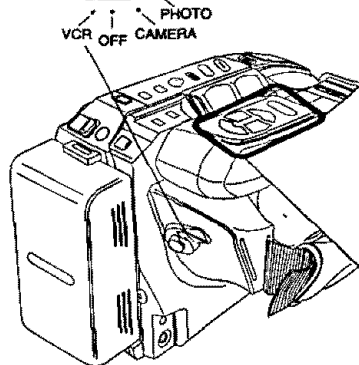

- 4** Presione PLAY para comenzar la reproducción.

- 5** Presione STOP para finalizar la reproducción.

Reproducción con efectos especiales

Para localizar rápidamente una escena específica

- Oprimir el botón de localización (SEARCH).

Para congelar una imagen

- Oprimir el botón de pausa/imagen fija (PAUSE/STILL).
- Oprimir nuevamente el botón cuando se desea continuar reproduciendo.

Panasonic Consumer Electronics
Company, Division of Matsushita
Electric Corporation of America
One Panasonic Way Secaucus,
New Jersey 07094

Panasonic Sales Company,
Division of Matsushita Electric of
Puerto Rico, Inc. ("PSC")
Ave. 65 de Infantería, Km. 9.5
San Gabriel Industrial Park
Carolina, Puerto Rico 00985



Printed in Japan
LSQT0203A
S0100.0