

Digital Palmcorder®

**Panasonic®**

Digital Video Camcorder  
**Operating Instructions**

Model No. **PV-DV601**

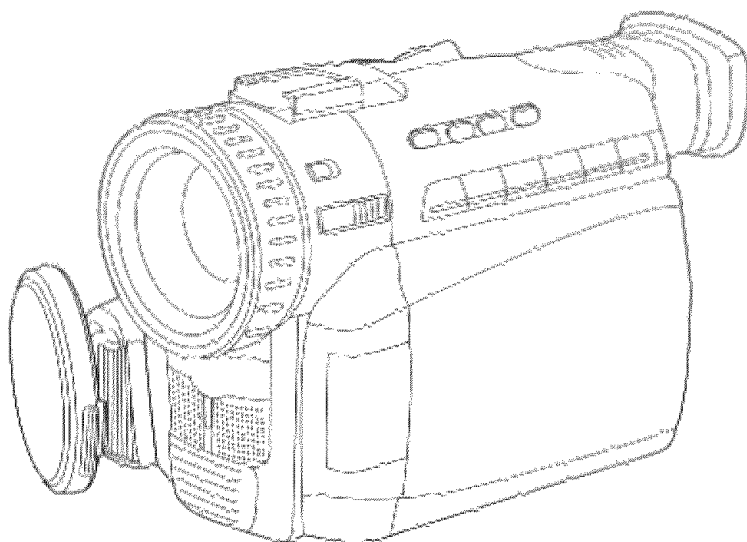

**MultiMediaCard™**



Mini **DV**

Before attempting to connect, operate or adjust this product, please read these instructions thoroughly.

Spanish Quick Use Guide is included.

Guía para rápida consulta en español está incluida.

For assistance, please call : 1-800-211-PANA(7262) or  
send e-mail to : [consumerproducts@panasonic.com](mailto:consumerproducts@panasonic.com)

LSOT0365A

# Things You Should Know

## Thank you for choosing Panasonic!

You have purchased one of the most sophisticated and reliable products on the market today. Used properly, we're sure it will bring you and your family years of enjoyment. Please take time to fill in the information below. The serial number is on the tag located on the underside of your Palmcorder. Be sure to **retain this manual** as your convenient Palmcorder information source.

Date of Purchase

Dealer Purchased From

Dealer Address

Dealer Phone No.

Model No.





Serial No.

## Safety Precautions

### WARNING: TO PREVENT FIRE OR SHOCK HAZARD, DO NOT EXPOSE THIS EQUIPMENT TO RAIN OR MOISTURE.

Your <sup>Mini</sup>IN Palmcorder is designed to record and play back in Standard Play (SP) mode and Long (LP) mode.

It is recommended that only cassette tapes that have been tested and inspected for use in VCR machines with the <sup>Mini</sup>IN mark be used.

 	<b>CAUTION</b> RISK OF ELECTRIC SHOCK DO NOT OPEN
<b>CAUTION: TO REDUCE THE RISK OF ELECTRIC SHOCK, DO NOT REMOVE COVER (OR BACK) NO USER-SERVICEABLE PARTS INSIDE REFER SERVICING TO QUALIFIED SERVICE PERSONNEL</b>	
	This symbol warns the user that uninsulated voltage within the unit may have sufficient magnitude to cause electric shock. Therefore, it is dangerous to make any kind of contact with any inside part of this unit.
	This symbol alerts the user that important literature concerning the operation and maintenance of this unit has been included. Therefore, it should be read carefully in order to avoid any problems.

### The above markings are located on the appliance bottom cover.

This device complies with Part 15 of the FCC Rules. Operation is subject to the following two conditions: (1) This device may not cause harmful interference, and (2) this device must accept any interference received, including interference that may cause undesired operation.

**Note:** This equipment has been tested and found to comply with Part 15 of the FCC Rules. These limits are designed to provide reasonable protection against harmful interference when operated in a residential environment.

If this equipment does cause interference to radio or television reception, which can be determined by turning the equipment off and on, use the equipment in another location and/or utilize an electrical outlet different from that used by the receiver.

If necessary, consult the dealer or an experienced radio/TV technician for help. You may find the booklet, 'Something About Interference' available from FCC local regional offices helpful.

**FCC Warning:** To assure continued FCC compliance, use only the provided shielded interface cable when connecting digital video camera to computer in accordance with instruction herein. Also, any unauthorized changes or modifications to this equipment could void the user's authority to operate.

# Important Safeguards

1. **Read Instructions** — All the safety and operating instructions should be read before the unit is operated.
2. **Retain Instructions** — The safety and operating instructions should be retained for future reference.
3. **Heed Warnings** — All warnings on the unit and in the operating instructions should be adhered to.
4. **Follow Instructions** — All operating and maintenance instructions should be followed.
5. **Cleaning** — Unplug this video unit from the wall outlet before cleaning. Do not use liquid or aerosol cleaners. Use a dry cloth for cleaning.
6. **Attachments** — Do not use attachments not recommended by the video product manufacturer as they may be hazardous.
7. **Water and Moisture** — Do not use this video unit near water — for example near a bath tub, wash bowl, kitchen sink, or laundry tub, in a wet basement, or near a swimming pool, and the like.
8. **Accessories** — Do not place this video unit on an unstable cart, stand, tripod, bracket, or table. The video unit may fall, causing serious injury to a child or adult, and serious damage to the unit. Use only with a cart, stand, tripod, bracket, or table recommended by the manufacturer, or sold with the video unit. Any mounting of the unit should follow the manufacturer's instructions and should use a mounting accessory recommended by the manufacturer. An appliance and cart combination should be moved with care. Quick stops, excessive force, and uneven surfaces may cause the appliance and cart combination to overturn.



9. **Ventilation** — Slots and openings in the cabinet are provided for ventilation and to ensure reliable operation of the video unit and to protect it from overheating. These openings must not be blocked or covered. Never place the video unit on a bed, sofa, rug, or other similar surface, or near or over a radiator or heat register. This video unit should not be placed in a built-in installation such as a bookcase or rack unless proper ventilation is provided or the manufacturer's instructions have been adhered to.
10. **Power Sources** — This video unit should be operated only from the type of power source indicated on the marking label. If you are not sure of the type of power supply to your home, consult your appliance dealer or local power company. For video units intended to be operated from battery power, or other sources, refer to the operating instructions.

11. **Grounding or Polarization** — This video unit may be equipped with either a polarized 2-wire AC (Alternating Current) line plug (a plug having one blade wider than the other) or 3-wire grounding type plug, a plug having a third (grounding) pin. The 2-wire polarized plug will fit into the power outlet only one way. This is a safety feature. If you are unable to insert the plug fully into the outlet, try reversing the plug. If the plug still fails to fit, contact your electrician to replace your obsolete outlet. Do not defeat the safety purpose of the polarized plug. The 3-wire grounding type plug will fit into a grounding type power outlet. This is a safety feature. If you are unable to insert the plug into the outlet, contact your electrician to replace your obsolete outlet. Do not defeat the safety purpose of the grounding type plug.
12. **Power-Cord Protection** — Power-supply cords should be routed so that they are not likely to be walked on or pinched by items placed upon or against them, paying particular attention to cords of plugs, convenience receptacles, and the point where they exit from the unit.
13. **Outdoor Antenna Grounding** — If an outside antenna or cable system is connected to the video unit, be sure the antenna or cable system is grounded so as to provide some protection against voltage surges and built-up static charges. Part 1 of the Canadian Electrical Code, in USA Section 810 of the National Electrical Code, provides information with respect to proper grounding of the mast and supporting structure, grounding of the lead-in wire to an antenna discharge unit, size of grounding conductors, location of antenna discharge unit, connection to grounding electrodes, and requirements for the grounding electrode.

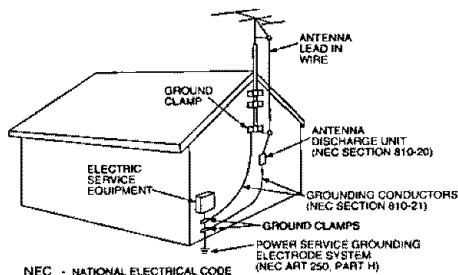

14. **Lightning** — For added protection of this video unit receiver during a lightning storm, or when it is left unattended and unused for long periods of time, unplug it from the wall outlet and disconnect the antenna or cable system. This will prevent damage to the video unit due to lightning and power-line surges.

# Important Safeguards

15. **Power Lines** — An outside antenna system should not be located in the vicinity of overhead power lines or other electric light or power circuits, or where it can fall into such power lines or circuits. When installing an outside antenna system, extreme care should be taken to keep from touching such power lines or circuits as contact with them might be fatal.
16. **Overloading** — Do not overload wall outlets and extension cords as this can result in a risk of fire or electric shock.
17. **Objects and Liquids** — Never push objects of any kind into this video unit through openings as they may touch dangerous voltage points or short out parts that could result in a fire or electric shock. Never spill liquid of any kind onto the video unit.
18. **Servicing** — Do not attempt to service this video unit yourself as opening or removing covers may expose you to dangerous voltage or other hazards. Refer all servicing to qualified service personnel.
19. **Damage Requiring Service** — Unplug this video unit from the wall outlet and refer servicing to qualified service personnel under the following conditions:
  - a. When the power-supply cord or plug is damaged.
  - b. If any liquid has been spilled into, or objects have fallen onto, the video unit.
  - c. If the video unit has been exposed to rain or water.
  - d. If the video unit does not operate normally by following the operating instructions. Adjust only those controls that are covered by the operating instructions, as an improper adjustment of other controls may result in damage and will often require extensive work by a qualified technician to restore the video unit to its normal operation.
  - e. If the video unit has been dropped or the cabinet has been damaged.
  - f. When the video unit exhibits a distinct change in performance — this indicates a need for service.
20. **Replacement Parts** — When replacement parts are required, be sure the service technician has used replacement parts specified by the manufacturer or have the same characteristics as the original part. Unauthorized substitutions may result in fire, electric shock or other hazards.
21. **Safety Check**— Upon completion of any service or repairs to this video unit, ask the service technician to perform safety checks to determine that the video unit is in safe operating order.

## Precautions

### USE & LOCATION

- **TO AVOID SHOCK HAZARD ...** Your Palmcorder and power supply should not be exposed to rain or moisture. Do not connect the power supply or operate your Palmcorder if it gets wet. Your Palmcorder has been designed for outdoor use, however it is not designed to sustain direct exposure to water, rain, sleet, snow, sand, dust, or direct splashing from a pool or even a cup of coffee. This action could permanently damage the internal parts of your Palmcorder. Do not attempt to disassemble this unit. There are no user serviceable parts inside. Unplug your Palmcorder from the power supply before cleaning.
- **DO NOT AIM YOUR PALMCORDER AT THE SUN OR OTHER BRIGHT OBJECTS**
- **DO NOT LEAVE THE PALMCORDER WITH THE EVF AIMED DIRECTLY AT THE SUN AS THIS MAY CAUSE DAMAGE TO THE INTERNAL PARTS OF THE EVF**
- **DO NOT EXPOSE YOUR PALMCORDER TO EXTENDED HIGH TEMPERATURE ...** Such as, direct sunlight, inside a closed car, next to a heater, etc... This action could permanently damage the internal parts of your Palmcorder.
- **AVOID SUDDEN CHANGES IN TEMPERATURE ...** If the unit is suddenly moved from a cold place to a warm place, moisture may form on the tape and inside the unit.
- **DO NOT LEAVE YOUR PALMCORDER OR THE POWER SUPPLY TURNED ON WHEN NOT IN USE.**
- **STORAGE OF YOUR PALMCORDER ...** Store and handle your Palmcorder in a manner that will not subject it to unnecessary movement (avoid shaking and striking). Your Palmcorder contains a sensitive pick-up device which could be damaged by improper handling or storage.

### CARE

- **TO CLEAN YOUR PALMCORDER ...** Do not use strong or abrasive detergents when cleaning your Palmcorder body.
- **TO PROTECT THE LENS ...** Do not touch the surface of the lens with your hand. Use a commercial Palmcorder lens solution and lens paper when cleaning the lens. Improper cleaning can scratch the lens coating.
- **TO PROTECT THE FINISH OF YOUR PALMCORDER ...** Before handling your Palmcorder, make sure your hands and face are free from any chemical products, such as suntan lotion, as it may damage the finish.

## **Getting Started**

Things You Should Know .....	2
Important Safeguards .....	3
Precautions .....	4
Before Using .....	6
Quick Guide .....	9
Supplying Power .....	11
Setting the Clock .....	13
Using the Palmcorder Menu .....	14
MENU OSD .....	15
Electronic Viewfinder/LCD Monitor Indications .....	19

## **Basic Operation**

Camera Recording .....	22
Remote Control .....	25
Playback Your Recordings .....	27

## **Special Features**

Card Features .....	32
Dual Digital Electronic Image Stabilization System (D.E.I.S.) .....	39
Digital Zoom .....	40
Digital PhotoShot .....	41
Index Search .....	41
White Balance .....	42
Recording Still Pictures .....	42
MAGICVU/OLUX .....	42
Program AE .....	43
Other Digital Functions .....	44
Picture in Picture (PiP) .....	45
Strobe Multi Mode .....	46
Focus .....	47
Backlight .....	47
High Speed Shutter .....	48
Audio/Video Fade In/Out .....	48
Audio Dubbing using the External or Built-in Microphone .....	49
Memory-Stop Editing .....	50
Copying your Tapes to S-VHS or VHS Cassette .....	51
Copying S-VHS or VHS Cassette to your Tapes .....	52
Copying from Digital Equipment (dubbing) .....	53
Transferring Your Images .....	54
Transferring Your Images (i.LINK) .....	63

## **For Your Information**

Palmcorder Accessory System .....	65
Palmcorder Accessory Order Form .....	67
Notes On Operations .....	68
Specifications .....	69
Before Requesting Service .....	70
Request for Service Notice .....	71
Index of Controls .....	72
Limited Warranty .....	76
Servicenter .....	77
Spanish Quick Use Guide/Guía Para Uso Rápido .....	78
Index .....	Back Cover

## Unpack your Palmcorder

1 pc. AC Adaptor  
(PV-DAC11) with AC Cable and DC Cable

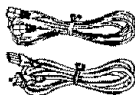

1 pc. Battery Pack  
(PV-DBP8A)



1 pc. 8 MB  
MultiMediaCard  
(LSFT0198A)



1 pc. A/V Cable  
(LSJA0280)



1 pc. Lens Cap  
(LSYF0478)



1 pc. USB Cable  
(LSJA0354)



1 pc. Shoulder  
Strap (LSFC0013)



1 pc. IR Remote  
Control (LSSQ0294)  
with Battery (CR2025)

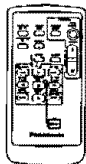

1 pc. CD-ROM of Driver Software for  
Windows 98/Me / USB Device Driver for  
Windows 98/Me/ CARD LINK (for USB) for  
Windows 98/Me / PHOTOVU LINK/Movie  
Messenger for Windows 98/Me/ ArcSoft  
Software for Windows 98/Me (LSFT0247)



Microsoft® and Windows® are registered trademarks of Microsoft in the United States and other countries.

Intel® Pentium® is a registered trademark.

i.LINK and i are trademarks.

PHOTOVU LINK/Movie Messenger is a registered trademark.

IBM is a registered trademark of IBM Company.

MultiMediaCard is a registered trademark.

SD is a trademark.

## Record Speed/Playback Time

Use only those tapes having the mini DV logo indicating the 6.35 mm digital standard.

Cassette type	Record Speed/ Playback time	
	SP	LP
AY-DVM30EA	30 minutes	45 minutes
AY-DVM60EA	60 minutes	90 minutes
AY-DVM80EA	80 minutes	120 minutes

## Erase Protection

Cassettes have a sliding record tab to ensure recordings are not accidentally erased.

**1 To prevent accidental erasure:**  
Slide the tab to the left (open).

record tab



**2 To record again:**  
Slide the tab to the right (close).



## Cassette Insertion/Removal

- If the Palmcorder is connected to a power source, the cassette can be inserted and ejected without turning the Palmcorder on.

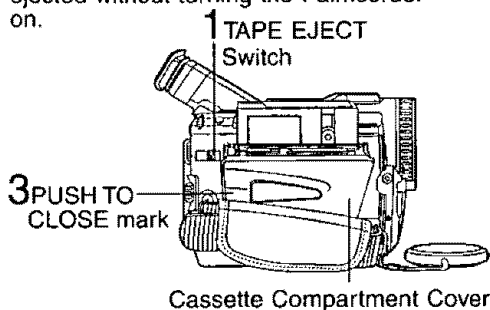

## Before you begin

- Connect the Palmcorder to a power source. (See pages 11, 12.)

- 1 Slide **TAPE EJECT** to open the Cassette Compartment Cover.
- 2 Insert a cassette record tab up, window side facing out.
- 3 Press **PUSH TO CLOSE** mark to close the Cassette Compartment Cover.

- **To remove the cassette...**  
Slide **TAPE EJECT** to open the Cassette Compartment Cover and pull the cassette tape straight out.

## Hint to locate recording position when inserting cassette

- When you insert a partially recorded cassette, use the Edit Search Function (see page 24) to visually confirm the point at which you want to start a new recording. Especially advisable when you want to add a recording to a tape that is already full.

### Note

- If hand strap is tight it may prevent Cassette Compartment Cover from fully opening for tape insertion or ejection. Loosen hand strap if necessary.
- When inserting the cassette, make sure it faces in the right direction and then push in completely.

## Using the Built-in Light

To brighten the natural colors in a scene.

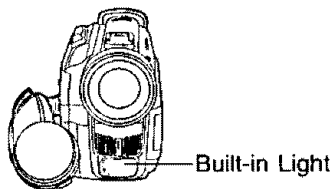

### Note

- Using Light reduces battery operating time.
- Be sure to provide adequate ventilation if using Light in a hot environment for an extended period.
- Be sure **LIGHT** is set to **OFF** when not in use.
- If light bulb needs to be replaced, take Light to your nearest authorized Servicerenter.

## Before you begin

- Connect the Palmcorder to a power source. (See pages 11, 12.)
- Set **POWER** to **CAMERA**.

- 1 Press **MENU** to display the **CAMERA** mode menu screen.
- 2 Rotate **JOG KEY** to select **SET-UP**, and press **JOG KEY** to display the **CAMERA SET-UP** menu screen.
- 3 Rotate **JOG KEY** to select **LIGHT**, and press **JOG KEY** to select **ON** or **OFF**.

## Caution

This light becomes hot during operation. Make sure nothing covers the Light during operation.

## Replacing the Bulb

- 1 While pressing up portion (A) with your fingernail, pull the cover straight out.

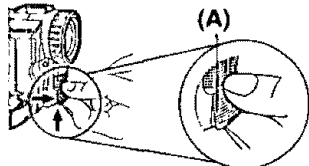

- 2 Using Tweezers or needle-nose pliers, carefully remove bulb.

- Take unit to service center if you need assistance.

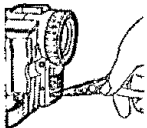

## Before you begin

- Set POWER to OFF.

- 3 Replace bulb using a clean cloth or tissue. (Do not touch with fingers.)

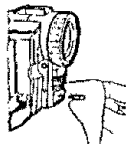

- 4 Replace lens cover.

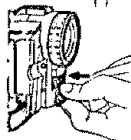

### Note

- Handle bulb gently. Excessive force may cause bulb to crack.

## DANGER:

Use only replacement bulb (PART NO. LSL0028) supplied by Panasonic to reduce risk of fire. Handle new bulb with cloth or tissue as skin oils decrease bulb life. Remove lens cover and allow bulb to cool before replacing to avoid possible burn hazard.

## Attaching the Shoulder Strap

- 1 Undo the two strap ends from their buckles.



- 2 Thread the strap ends through the Strap Attachment Rings.



- 3 Reinsert the strap ends through their buckles.

- Make sure the straps are not twisted.



## Adjust the Length

- 1 Loosen the strap from the Buckle and create a loop.

- 2 Pull the strap firmly through the Buckle to shorten or lengthen the strap.

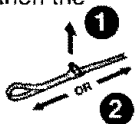

## Hand Strap

Adjust the length of the Hand Strap to the size of your hand as illustrated.

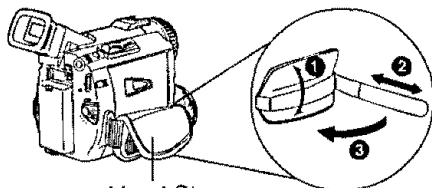

Hand Strap

## Lens Cap

Attaching the Lens Cap Cord to the Hand Strap

Remove the Hand Strap from the front clasp and thread the Strap through the loop in the Lens Cap Cord. Reattach the Hand Strap.

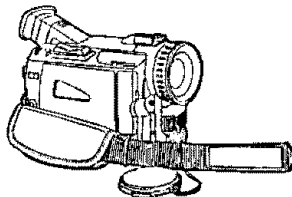



**Insert the Battery Pack**

**Before you begin**  
 • Charge the Battery. (See page 11.)

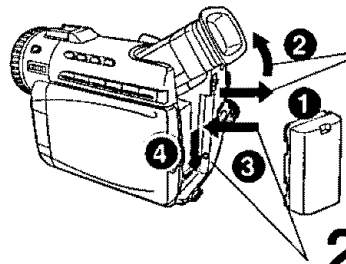

**1** Slide the Viewfinder backward to its fully expanded position and then tilt it upward.

**2** Insert the Battery Pack and slide it down until it locks with a click.

**Insert Cassette**

**1** Set POWER Switch to VCR or CAMERA.

**2** Slide TAPE EJECT Switch to open the Cassette Compartment Cover.

**3** Insert a cassette record tab up, window side facing out.  
 • Make sure the record tab is closed. (See page 6.)

**4** Press PUSH TO CLOSE mark to close the Cassette Compartment Cover.

**Protection Film**  
**Note**  
 • Remove the Protection Film before use.

**Camera Recording**

When the LCD monitor is fully open, the Viewfinder automatically turns OFF.

**2** Adjust the Vision Adjustment Control to your eyesight.

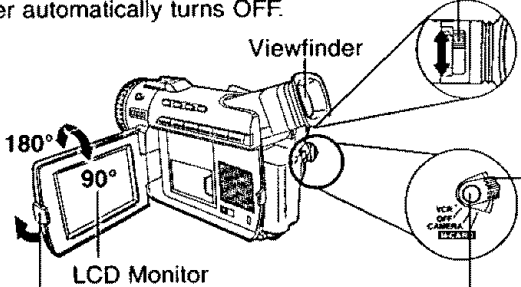

**1** Set POWER Switch to CAMERA.

**3** Press LCD-OPEN Button to unlock the LCD monitor. Swing it fully open and adjust the angle.

**4** Press REC/PAUSE Button to start recording. Press REC/PAUSE Button again to pause recording.

## Insert Memory Card\*

## Before you begin

- Charge the Battery. (See page 11.)

\*Memory Card: MultiMediaCard or SD Memory Card (See page 65.)

• Be sure to insert the Memory Card before using the Card PhotoShot. (See page 32.)

Below is a list of memory cards which can be used in this Palmcorder.

Memory Card	Capacity
MultiMediaCard (LSFT0198A) (supplied)	8 MB
MultiMediaCard (SanDisk brand)	8 MB, 16 MB
SD Memory Card (optional) (See page 65.)	16 MB, 32 MB, 64 MB

## SD Memory Card write protection switch



A write protection switch is located on the SD Memory Card. Sliding the switch to the "LOCK" position prevents writing on or formatting the card.

Write protection switch

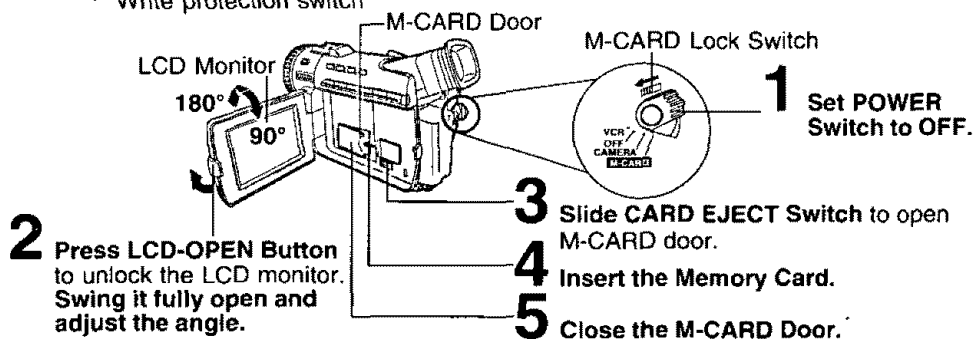

## To Watch Playback in the LCD (Liquid Crystal Display)

When the LCD monitor is fully open, the Viewfinder automatically turns OFF.

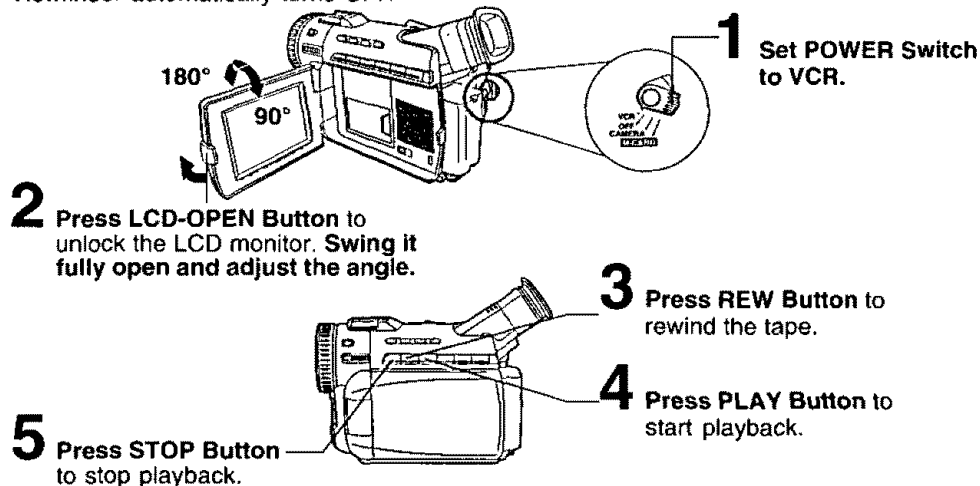

10

## Charge the Battery Pack on the AC Adaptor

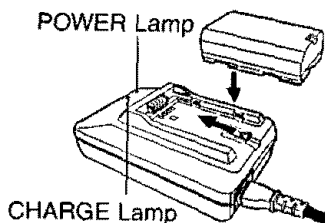
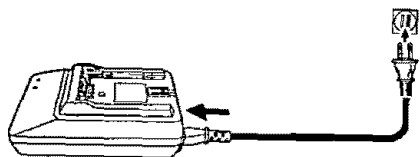

- 1** Connect and plug in the Power Cord as shown.
  - POWER Lamp will light.
  - Remove the DC Cable, if attached, from the adaptor.
- 2** Attach the Battery as shown to charge.
  - CHARGE Lamp lights up. It goes out when charging is complete (approx. 1 hour). Expect approx. 1 hour 30 minutes of operation (EVF usage) when fully charged.
- 3** Remove the Battery. Slide the Battery out and then lift up.

### Note

#### About the Flashing of the CHARGE Lamp

- Charge the Battery within an ambient temperature range of 10 °C and 30 °C.
  - If charging is done in extreme low or high temperatures, Battery charge time increases.
- CHARGE Lamp flashes when...**
- The Battery is being charged, but charging is taking longer than normal.
  - Charging is not possible. Remove the Battery once, wait a short time, then re-attach it for charging.

## Insert the Battery Pack

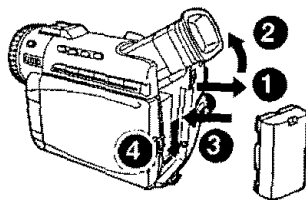

- 1** Slide the Viewfinder backward to its fully extended position and then tilt it upward.
- 2** Insert the Battery Pack and slide it down until it locks with a click.

## Remove the Battery Pack

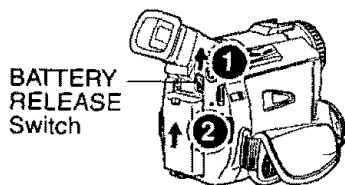

- To remove the Battery Pack:**  
Slide the Battery upward while sliding the BATTERY RELEASE Switch.

## Battery Care

### Caution:

- Charge only with specified charger.
- Charge the Battery within an ambient temperature range of 32° F (0° C) and 104° F (40° C).
- The Battery may be warm after charging or just after use. This is normal.
- Do not use an insufficiently charged or worn out Battery.
- If charging is done in extreme low or high temperatures, Battery charge time increases.

### Safety precautions:

- Do not get the Battery near, or dispose of in fire.
- Do not directly connect (short circuit) the positive (+) and negative (-) terminals.
- Never attempt to disassemble or reassemble the Battery.

## Use AC Adaptor

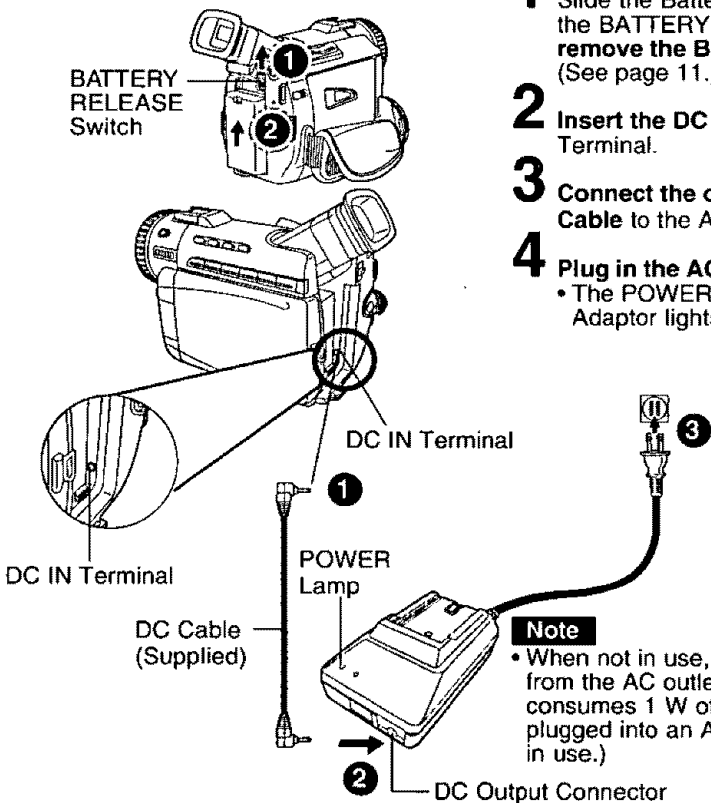

### To avoid damage to the Battery:

- Do not drop or jar the Battery.
- Use the Battery with specified models only.
- If the Battery is used in extremely high temperatures, a safety device will automatically prevent operation.

### To insure longer battery life:

- While not in use, remove Battery from the Palmcorder and AC Adaptor and store in a cool, dark, dry place. If you leave the Battery in the Palmcorder or on the AC Adaptor, the Battery will no longer be rechargeable.
- Keep the Battery terminals clean.

## Set the Date and Time

The date and time is calculated, including leap year, up to DEC 31 2089.

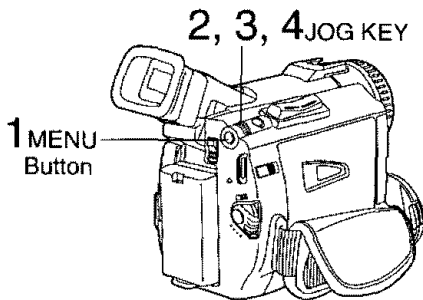

### EXAMPLE:

**YEAR** : 2001



Push

**MONTH** : JAN



Rotate

**MONTH** : FEB

### Note

- To make corrections, Press JOG KEY repeatedly to move back to an item and correct.
- A built-in Battery maintains clock operation. If the Palmcorder is not connected to a power source for a few months, the built-in battery may discharge and "CLOCK BATTERY" indication appears. (See page 21.)

## Before you begin

- Connect the Palmcorder to a power source. (See pages 11, 12).
- Set POWER to CAMERA or VCR.

- 1 Press **MENU** to display the Camera or VCR mode menu screen. (See page 14.)

### [ CAMERA MENU ] [ VCR MENU ]

CAMERA MENU	
1:FUNCTION	
2:ADJUST	
3:REC MODE	
4:SET-UP	
5:DISPLAY SETTING	
6:LCD/EVF SETTING	
7:PHOTO TITLE	
*SELECT: ROTATE JOG KEY	
*SET : PUSH JOG KEY	
*EXIT : PUSH MENU KEY	

VCR MENU	
1:PLAY FUNCTION	
2:REC MODE	
3:PLAY MODE	
4:MULTI SETTING	
5:DISPLAY SETTING	
6:LCD/EVF SETTING	
*SELECT: ROTATE JOG KEY	
*SET : PUSH JOG KEY	
*EXIT : PUSH MENU KEY	

- 2 Rotate **JOG KEY** to select **DISPLAY SETTING**, and then press **JOG KEY** to display the DISPLAY SETTING menu screen.

- 3 Rotate **JOG KEY** to select **CLOCK-SET**, and then press **JOG KEY** to set to ON. (See pages 16, 18.)
  - The DATE/TIME SETTING menu is displayed.

- 4 Rotate **JOG KEY** to select YEAR, then press **JOG KEY** to fix and move to the next item. Likewise, set the month, day, hour, and minutes.

DATE/TIME SETTING	
YEAR	: 2001
MONTH	: OCT
DAY	: 10
HOUR	: 8PM
MINUTE	: 10
*SELECT: PUSH JOG KEY	
*SET : ROTATE JOG KEY	
*EXIT : PUSH MENU KEY	

When DATE/TIME setting is completed, press MENU three times to start the clock and exit.

# Using the Palmcorder

The Palmcorder features three menu displays: one for CAMERA mode (recording), one for M-CARD (Memory Card Photo Mode) and one for VCR mode (Playback). (See pages 15~18.)

- While the Menu screen is displayed, you cannot record on or play a tape.
- While recording, the Menu screen cannot be displayed.
- During playback, the Menu screen can be displayed.

## Before you begin

- Connect the Palmcorder to a power source. (See pages 11, 12.)
- Set POWER to CAMERA or VCR.

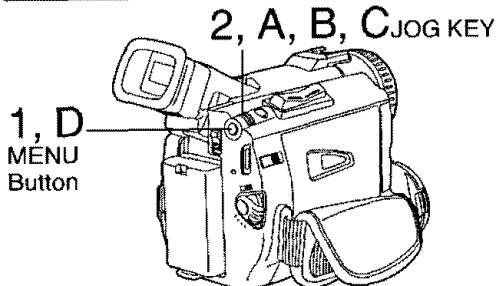

## Displaying the MENU

- 1 Press MENU to display the CAMERA or VCR menu (according to the POWER setting).
- 2 Rotate JOG KEY to select a menu item.

## Setting the MENU Items (EX. VCR Mode menu)

- A Press JOG KEY to set your selection.
- B Rotate JOG KEY to select a menu item.

VCR PLAY FUNCTION	
D.FUNCTION	OFF MIRROR
	STROBE MOSAIC
	SLIM TRAIL
	STRETCH
D.EFFECT	OFF SEPIA
	MONO
•SELECT: ROTATE JOG KEY	
•SET : PUSH JOG KEY	
•EXIT : PUSH MENU KEY	

VCR PLAY FUNCTION	
D.FUNCTION	OFF MIRROR
	STROBE MOSAIC
	SLIM TRAIL
	STRETCH
D.EFFECT	OFF SEPIA
	MONO
•SELECT: ROTATE JOG KEY	
•SET : PUSH JOG KEY	
•EXIT : PUSH MENU KEY	

- C Press JOG KEY to set your selection.
  - The "●" mark indicates selection.
- D Press MENU twice to exit the menu.

## CAMERA Main menu

- 1: **D. FUNCTION**  
CAMERA FUNCTION menu is displayed. To select one of the 10 digital functions (MIRROR, STROBE, MOSAIC, SLIM, TRAIL, STRETCH, GAIN-UP, WIPE, MIX, PinP).
- 2: **ADJUST**  
CAMERA ADJUST menu is displayed. To select PROG. AE, W. BALANCE, or H.S.S. (High Speed Shutter).
- 3: **REC MODE**  
CAMERA REC-MODE menu is displayed. To select REC-SPEED, AUDIO-REC, INDEX, SHUTTER, SELF-REC, or WIND-CUT.
- 4: **SET-UP**  
CAMERA SET-UP menu is displayed. To select REMOTE, BEEP, MAGICVU, or LIGHT.
- 5: **DISPLAY SETTING**  
DISPLAY SETTING menu is displayed. To select DISPLAY, C.RESET, DATE/TIME, or CLOCK-SET.
- 6: **LCD/EVF SETTING**  
LCD/EVF SETTING menu is displayed. To select LCD BRIGHTNESS, LCD COLOR or EVF BRIGHTNESS.
- 7: **PHOTO TITLE**  
PHOTO TITLE menu is displayed. To select TITLE or MODE.

## VCR Main menu

- 1: **PLAY FUNCTION**  
VCR PLAY FUNCTION menu is displayed. To select D. FUNCTION or D.EFFECT.
- 2: **REC MODE**  
VCR REC MODE menu is displayed. To select REC-SPEED or AUDIO-REC.
- 3: **PLAY MODE**  
VCR PLAY MODE menu is displayed. To select INDEX, AUDIO, REMOTE, or B.SEARCH.
- 4: **MULTI SETTING**  
MULTI SETTING menu is displayed. To select SPEED.
- 5: **DISPLAY SETTING**  
DISPLAY SETTING menu is displayed. To select DISPLAY, C.RESET, DATE/TIME, or CLOCK-SET.
- 6: **LCD/EVF SETTING**  
LCD/EVF SETTING menu is displayed. To select LCD BRIGHTNESS, LCD COLOR or EVF BRIGHTNESS.

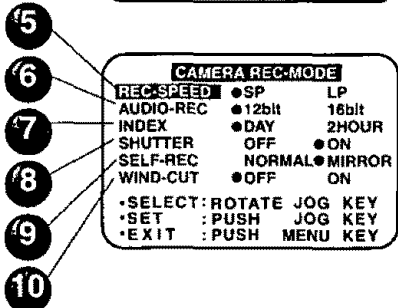
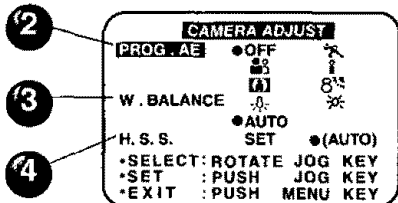
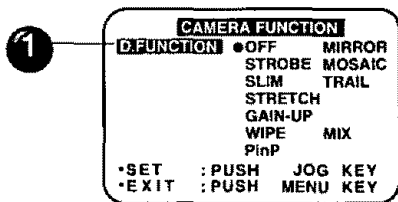

- 1 **DIGITAL FUNCTION** (See page 44.)  
 To select one of the 10 digital functions.  
 Setting to OFF cancels the previously selected digital function.
- 2 **PROG. AE** (See page 43.)  
 To select one of the 5 Program AE modes. Setting to OFF cancels the previously selected Program AE mode.
- 3 **W.BALANCE** (See page 42.)  
 To select one of the 3 White Balance modes.
- 4 **H. S. S. (High Speed Shutter)**  
 (See page 48.)  
 To select a desired shutter speed.
- 5 **REC-SPEED** (See page 6.)  
**SP:** Normal recording speed mode.  
**LP:** Recording time is 1.5 times as long as in the SP mode. For example, 120 minutes of recording is possible on a 80 minute tape.
- 6 **AUDIO-REC** (See page 49.)  
**12 bit:** The sound is recorded in the 12 bit/32 kHz mode.  
**16 bit:** The sound is recorded in the 16 bit/48 kHz high-quality mode.
- 7 **INDEX** (See page 30.)  
**DAY:** An index signal is recorded when recording is restarted after the date has changed since the last recording.  
**2 HOUR:** An index signal is recorded when recording is restarted after a lapse of more than 2 hours.
- 8 **SHUTTER** (See page 41.)  
 When set to ON, still pictures taken in the PhotoShot mode are recorded with a visual shutter effect and click sound.
- 9 **SELF-REC** (See page 23.)  
**NORMAL:** During self-recording, the picture on the LCD Monitor is the same as it will be recorded.  
**MIRROR:** During self-recording, the picture on the LCD Monitor is horizontally reversed.
- 10 **WIND-CUT** (See page 22.)  
 To reduce sound distortion caused by wind hitting the microphone. However, this slightly deteriorates the sound reproduction in the bass range.

**11** **CAMERA SET-UP**

**12** **REMOTE** OFF

**13** **BEEP** ●VCR1 VCR2

**14** **MAGICVU** ●OFF ON

●B/W BLUE

GREEN

**15** **LIGHT** ●OFF ON

•SELECT: ROTATE JOG KEY

•SET : PUSH JOG KEY

•EXIT : PUSH MENU KEY

**15** **DISPLAY SETTING**

**16** **DISPLAY** OFF ●LINEAR

**17** C. RESET ●MEMORY T. CODE

**18** DATE/TIME ●OFF ON

●D/T DATE

**19** **CLOCK-SET** ●OFF ON

•SELECT: ROTATE JOG KEY

•SET : PUSH JOG KEY

•EXIT : PUSH MENU KEY

**19** **LCD/EVF SETTING**

LCD BRIGHTNESS

LOW ||||| ----- HIGH

LCD COLOR

LOW ||||| ----- HIGH

EVF BRIGHTNESS

LOW ||||| ----- HIGH

•SELECT: PUSH JOG KEY

•SET : ROTATE JOG KEY

•EXIT : PUSH MENU KEY

**20** **PHOTO TITLE**

**21** **TITLE** ●OFF SET

**MODE** ●WIPE MIX

•SELECT: ROTATE JOG KEY

•SET : PUSH JOG KEY

•EXIT : PUSH MENU KEY

**11 REMOTE** (See page 26.)

**VCR1:** To receive signals from the Remote Control, set to VCR1.

**VCR2:** To receive signals from the Remote Control, set to VCR2.

**OFF:** To prevent reception of signals from the Remote Control.

**12 BEEP**

Set to ON to hear beep when starting and stopping camera recording or when unusual conditions occur. To cancel the beep, set to OFF.

Palmcorder will beep:  
Once when you start recording  
Twice when you stop recording  
Repeatedly when warning of unusual conditions.  
(See page 21.)

**13 MAGICVU**  
(See page 42.)

To select one of the 3 MAGICVU modes slide MAGICVU/OLUX Switch to ON.

**14 LIGHT**  
(See page 7.)

When set to ON, the Built-in Light lights up.

**15 DISPLAY** (See page 19.)

To select the desired type of display and counter indication displayed on the LCD Monitor or in the viewfinder.

**16 C.RESET** (See page 19.)

Setting to ON resets the counter to zero.

**17 DATE/TIME** (See page 20.)

The date and time can be set and displayed on the screen.

**18 CLOCK-SET** (See page 13.)

When set to ON, the date and time can be set on the screen.

**19 LCD/EVF SETTING** (See page 23.)

Setting to ON displays the menu for adjusting the LCD brightness, color level, and the EVF brightness.

**20 TITLE** (See page 38.)

Photo Title is recorded.

**21 MODE** (See page 38.)

To select one of the 2 Photo Title modes.



## VCR Mode Menu Screen

**1** **VCR PLAY FUNCTION**

**D. FUNCTION** ●OFF MIRROR  
 STROBE MOSAIC  
 SLIM TRAIL  
 STRETCH

**2** **D. EFFECT** ●OFF SEPIA  
 MONO

•SELECT: ROTATE JOG KEY  
 •SET : PUSH JOG KEY  
 •EXIT : PUSH MENU KEY

**3** **VCR REC MODE**

**REC-SPEED** ●SP LP

**4** **AUDIO-REC** ●12bit 16bit

•SET : PUSH JOG KEY  
 •EXIT : PUSH MENU KEY

**5** **VCR PLAY MODE**

**6** **INDEX** ●PHOTO SCENE

**7** **AUDIO** ●ST1 ST2  
 ●MIX

**7** **REMOTE** ●OFF  
 VCR1 VCR2

**8** **B. SEARCH** ●OFF ON

•SELECT: ROTATE JOG KEY  
 •SET : PUSH JOG KEY  
 •EXIT : PUSH MENU KEY

- 1** **DIGITAL FUNCTION** (See page 44.)  
To select one of the 6 digital functions. Setting to OFF cancels the previously selected digital function.
- 2** **D. EFFECT** (See page 44.)  
To select one of the 2 digital picture effects for playback. Setting to OFF cancels the previously selected digital effect.
- 3** **REC-SPEED** (See page 6.)  
**SP**: Normal recording speed mode.  
**LP**: Recording time is 1.5 times as long as in the SP mode. For example, 120 minutes of recording is possible on an 80 minute tape.
- 4** **AUDIO-REC** (See page 49.)  
**12 bit**: The sound is recorded in the 12 bit/32 kHz mode.  
**16 bit**: The sound is recorded in the 16 bit/48 kHz high-quality mode.
- 5** **INDEX** (See page 30.)  
To select the desired Index Search function.  
**PHOTO**: To search for Photo shot pictures.  
**SCENE**: To search for scenes marked with Index signal.
- 6** **AUDIO** (See page 50.)  
To select the desired audio playback mode after performing audio dubbing in the 12 bit mode (SP mode only).  
**ST1**: The original sound alone is played back.  
**ST2**: The dubbed sound alone is played back.  
**MIX**: The original sound and the dubbed sound are played back together.
- 7** **REMOTE** (See page 26.)  
**VCR1**: To receive signals from the Remote Control, set to VCR1.  
**VCR2**: To receive signals from the Remote Control, set to VCR2.  
**OFF**: To prevent reception of signals from the Remote Control.
- 8** **B. SEARCH (Blank Search)** (See page 25.)  
Select ON to go directly to a blank portion of the tape.

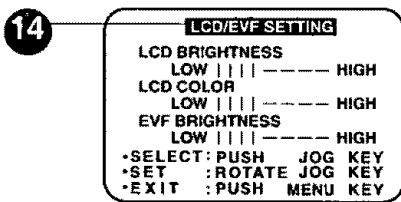
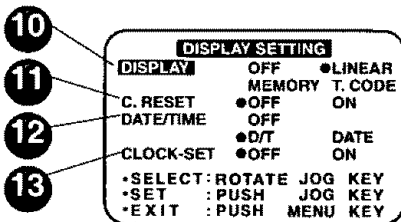
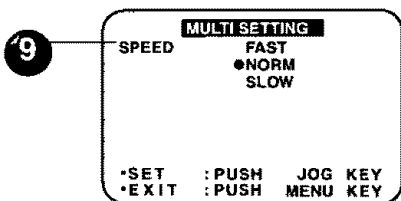

**9** **SPEED** (See page 46.)  
 In Strobe Multi mode, used to select the interval at which a succession of still screens are captured from the playback picture.  
**FAST** : Every 0.3 seconds  
**NORM** : Every 0.6 seconds  
**SLOW** : Every 1.0 seconds

**10** **DISPLAY** (See page 19.)  
 To select the desired type of display and counter indication displayed on the LCD Monitor or in the viewfinder.

**11** **C.RESET** (See page 19.)  
 Setting to ON resets the counter to zero.

**12** **DATE/TIME** (See page 19.)  
 The date and time can be set and displayed on the screen.

**13** **CLOCK-SET** (See page 13.)  
 When set to ON, the date and time can be set on the screen.

**14** **LCD/EVF SETTING** (See page 23.)  
 Setting to ON displays the menu for adjusting the LCD brightness, color level, and the EVF brightness.

## M-CARD Mode Menu Screen

[ Photo Rec Mode Menu Screen ]

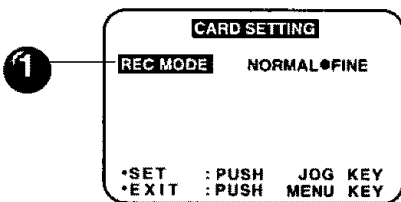

**1** **REC MODE** (See page 32.)  
 To select Photo Rec Mode.

**2** **DISPLAY** (See page 34.)  
 Select to OFF to cancel all Displays on the screen.

**3** **DCF** (See page 34.)  
 Select to OFF to cancel DCF No. on the screen.

[ Photo Play Mode Menu Screen ]

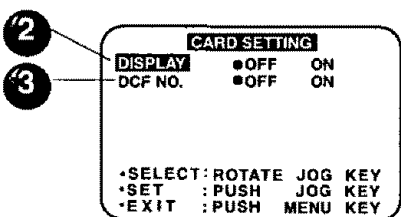

Here are some of the basic indications which will appear on the Palmcorder EVF and LCD Monitor. Only Date and Time indications will be recorded onto the tape.

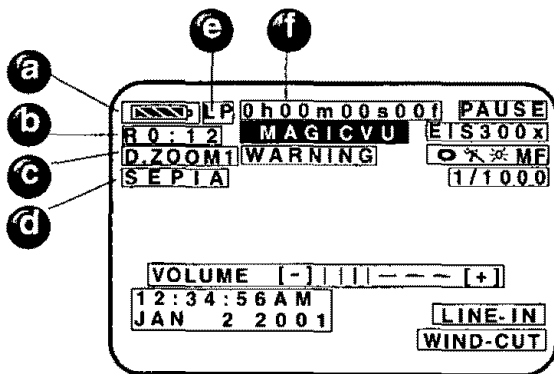

### a Battery Remaining

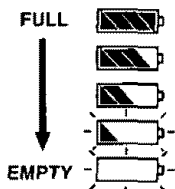

### b Tape Remaining

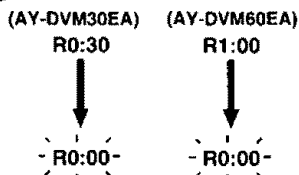

- It will take several seconds for the tape remaining indicator to operate after the tape starts moving.

### c Digital Zoom and other Digital Functions (See page 40.)

This display appears when the digital zoom function has been activated.

### d Playback Effect (See page 44.)

This display appears when SEPIA or MONO is selected in VCR menu.

### e Tape Speed Indication (See page 15.)

Indicates the tape speed (SP or LP).

### f Display ON/OFF and Counter/Time Code

The indication switches as shown below when the desired "DISPLAY" mode is selected from the menu. (See pages 16, 18.)

- When OFF is selected, all displays are turned off.

#### Linear Time Counter Memory Counter

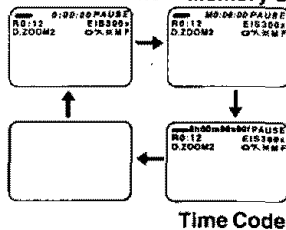

#### Time Code

#### Memory Counter M 0:00:00

The Palmcorder will stop whenever it reaches the point where the counter was previously set to M 0:00:00 during audio dub, fast forward, or rewind.

#### Time Code 0h00m00s00f

The Palmcorder calculates and displays exactly where you are on any tape in terms of hours, minutes, seconds, and frames (30 frames = 1 second).

- This display can not be reset.

#### IMPORTANT NOTE:

- Display must be set to ON for MF, AE, W.BALANCE or BACK LIGHT indications to be displayed on the EVF or LCD Panel when selected.
- C.RESET does not work when DISPLAY is set to OFF and T.CODE.

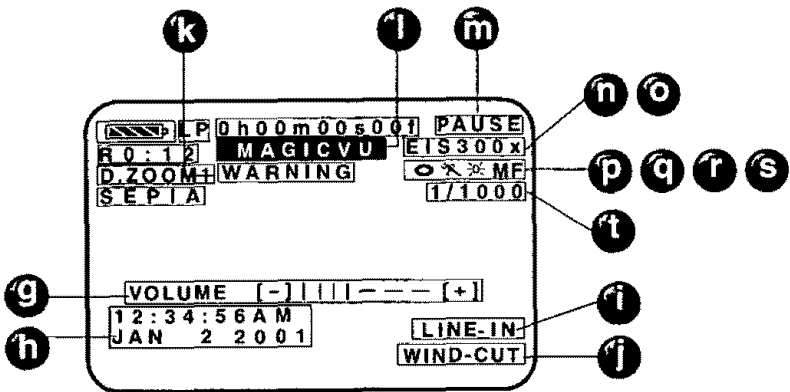

**g** **Volume Display** (See page 27.)  
The volume bar appears when the volume of the built-in speaker is being adjusted.

**h** **Date and Time Indication**  
(See pages 16, 18.)

As shown below, the date and time indication changes each time DATE/TIME is selected from the Palmcorder's MENU (see pages 16, 18) or the DATE/TIME Button is pressed on the remote.

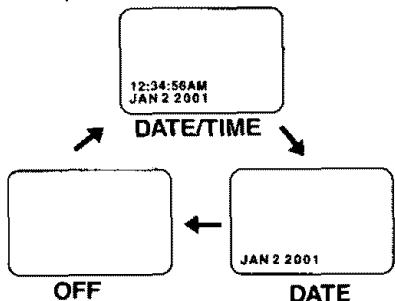

**i** **LINE-IN Mode Indication**  
(See page 52.)  
LINE-IN appears when IN is selected with the A/V SELECT Switch.

**j** **WIND-CUT Indication**  
(See page 15.)

**k** **WARNING Indication**  
(See page 21.)  
The warning displays appear in the EVF and the LCD monitor.

**l** **MAGICVU** (See page 16.)  
This display appears when MAGICVU is set to ON.

**m** **Tape Mode Indications**

REC	Recording.
PHOTO	PhotoShot recording.
PAUSE	Paused during recording.
PLAY	Playback.
R >	Repeat Playback.
CHK	Recording Check.
FF	Fast forward.
REW	Rewind.
>>	FF Search.
<<	REW Search.
BLANK	Blank Search.
SEARCH	Index Search.

**n** **Digital EIS Indications**  
(See page 39.)

**o** **Zoom Magnification Level**  
(See page 40.)

**p** **Manual Focus Indication**  
(See page 47.)





**q** **White Balance Indication**  
(See page 42.)

**r** **PROGRAM-AE Indication**  
(See page 43.)

**s** **Backlight Indication**  
(See page 47.)

**t** **Shutter Mode indication**  
(See page 48.)

The following warning displays appear in the EVF and the LCD monitor.

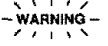
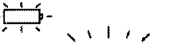
Indications	Condition
 <b>TAPE NOT INSERTED</b>	If the Palmcorder is in CAMERA mode without a cassette inserted, "TAPE NOT INSERTED" will flash and "TAPE NOT INSERTED" will appear for 5 seconds. Recording will not start.
 <b>CHECK REC TAB</b>	If the Palmcorder is in CAMERA mode with the cassette sliding record tab opened, "CHECK REC TAB" will flash and "CHECK REC TAB" will appear for 5 seconds. Recording will not start.
 <b>CANNOT REC</b>	When Audio dub is performed and the sliding record tab is open, or a blank portion of tape is detected, "CANNOT REC" will flash and "CANNOT REC" will appear for 5 seconds.
 <b>TAPE END</b>	When the tape is about to end in REC mode, "TAPE END" will flash and "TAPE END" will appear for 5 seconds.
<b>INCOMPATIBLE TAPE</b>	When an incompatible tape is detected, "INCOMPATIBLE TAPE" will appear for 5 seconds.
<b>NEED HEAD CLEANING</b>	If the video heads require cleaning, "NEED HEAD CLEANING" will appear for 5 seconds.
<b>REMOTE</b>	When the Palmcorder and remote are not set to the same mode (VCR1 or VCR2), "CHECK REMOTE MODE" appears for 5 seconds. Also appears when the Palmcorder is first turned on.
<b>CANNOT REC LP-MODE</b>	When an AUDIO DUB is attempted on a pre-recorded LP tape, "CANNOT REC LP-MODE" will appear for 5 seconds.
 <b>DEW DETECTED</b>	If excessive moisture condenses in the unit, "WARNING" will flash, "DEW DETECTED" will appear, and the Palmcorder will automatically turn OFF in 15 seconds. In this case, wait until the indicator no longer flashes when your Palmcorder is turned ON again.
 <b>LOW BATTERY</b>	When a battery recharge is necessary, "WARNING" will flash, "LOW BATTERY" will appear, and the Palmcorder will automatically turn OFF in 15 seconds. (See page 19.)
<b>CLOCK BATTERY</b>	When the built-in lithium clock battery is discharged, "CLOCK BATTERY" will appear. To re-charge the lithium clock battery, connect the AC Adaptor to the Palmcorder. Recharging takes approx. 4 hours. Reset the clock after charging.
<b>INCOMPATIBLE DATA</b>	If you play tape recorded in a format other than NTSC or you try to copy a copy-protected data. "INCOMPATIBLE DATA" will appear.
<b>NO SPACE LEFT</b>	When a still image is transferred from a tape to an already full Memory Card, "NO SPACE LEFT" appears.
<b>DISCONNECT DV CABLE</b>	If the Palmcorder is in M-CARD mode or Photo Title (CAMERA mode) and the DV Interface Cable (i.LINK) is connected, "DISCONNECT DV CABLE" appears. In this case, remove the DV Interface Cable (i.LINK) from the Palmcorder.

Camera

## Simple Recording

Remove the lens cap and clip it to the hand strap.

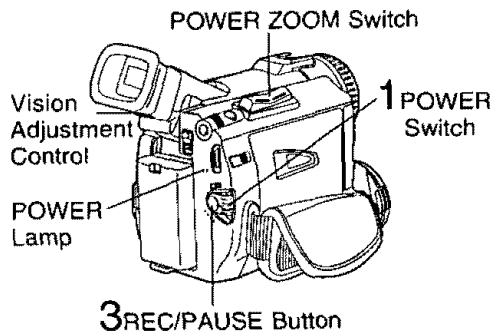
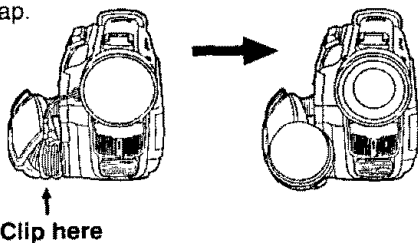

## Before you begin

- Connect the Palmcorder to a power source. (See pages 11, 12.)
- Insert a cassette with record tab closed. (See page 6.)

1

Set **POWER** to **CAMERA**.

- The **POWER** Lamp lights red.
- Be sure **POWER** is fully turned to **CAMERA** position.

**EVF**

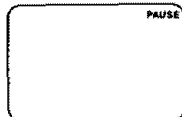

REC/PAUSE mode

2

With the **Viewfinder Eye Cup** up to your eye, adjust the **Vision Adjustment Control** to your eyesight. (See page 9.)

3

Press **REC/PAUSE** to start recording.

- "REC" is displayed on the screen. Press **REC/PAUSE** again to pause recording.
- To reduce microphone wind noise, set the **WIND-CUT** to **ON**. (See **WIND-CUT** on page 15.)

- When the Palmcorder is aimed at excessively bright objects, or bright lights, a vertical bar may appear in the picture. This is a normal characteristic of the CCD pick-up device. Try to avoid this whenever possible.

## WARNING:

- Do not leave the Palmcorder with the **EVF** aimed directly at the sun as this may cause damage to the internal parts of the **EVF**.
- Do not lift, or carry, the Palmcorder by the **EVF** or the **LCD Monitor**.

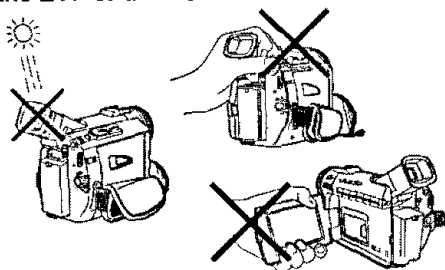

## To conserve power

After 5 minutes, the Record/Pause mode will automatically change to Standby mode. To resume recording, set **POWER** to **OFF** and then **ON** again.

## Zoom

You can gradually zoom in for close ups or zoom out for wide angle shots.

**Zoom slowly** : by lightly pressing the "T" (Telephoto) or the "W" (Wide Angle) side of the **POWER ZOOM Switch**.

**Zoom quickly** : by applying more pressure.

## Note

- The zooming speed ranges from a slow 22 seconds to a fast 2 seconds according to the amount of pressure applied to the **POWER ZOOM Switch**.

## Using the LCD Monitor

The LCD (Liquid Crystal Display) monitor can be used while recording.

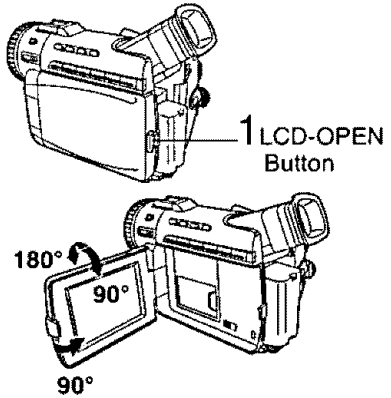

## To adjust the LCD BRIGHTNESS or COLOR

- A** Press **MENU** to display the main menu screen.
- B** Rotate **JOG KEY** to select **LCD/EVF SETTING** from the main menu screen. (See pages 16, 18.)
- C** Press **JOG KEY** to display the LCD/EVF SETTING screen.
- D** Press **JOG KEY** to select LCD BRIGHTNESS or LCD COLOR, then rotate **JOG KEY** to adjust.
- E** Press **MENU** twice to exit this mode.

## Before you begin

- Connect the Palmcorder to a power source. (See pages 11, 12.)
- Insert a cassette with record tab closed. (See page 6.)

- 1** Press **LCD-OPEN** to unlock the LCD monitor.
- 2** Swing the LCD monitor fully open and adjust the viewing angle.
  - The LCD monitor will automatically turn on.
  - When the LCD monitor is completely closed, it will shut off automatically to save power.
  - Adjust the LCD Brightness and/or color of the LCD monitor if necessary. Please refer to "To adjust the LCD BRIGHTNESS or COLOR" to the left.

- 3** Start recording. (See page 22.)

### Note

- Using the LCD monitor will reduce battery operating time.
- Close the LCD monitor completely when not in use.

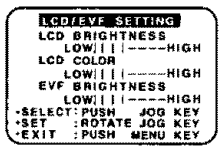

## Self Recording

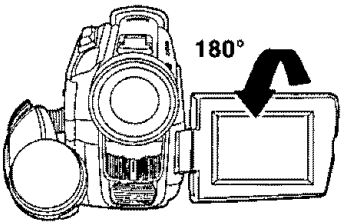

Rotate the LCD monitor 180 degrees so it faces the same direction as the lens to record yourself (CAMERA mode). The picture in the LCD monitor will appear reversed.

Set **SELF-REC** to MIRROR (see page 15) in the Camera mode menu screen to see the picture as it is actually being recorded.

Basic Operation

## Recording Check

To playback the final few seconds of the last recorded scene in the REC/PAUSE mode.

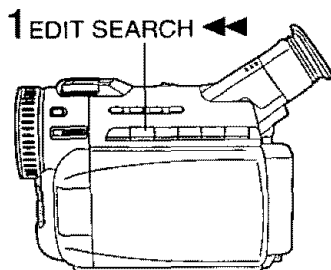

- 1 Press **EDIT SEARCH** ◀◀ briefly in the REC/PAUSE mode.

The [CHK] indication appears. After checking, the Palmcorder returns to the REC/PAUSE mode.

- For Recording Check, the Palmcorder must be in the same mode (SP or LP) as was used for recording, otherwise the playback picture is distorted.



## Edit Search

You can visually search for scenes in CAMERA mode to maintain proper continuity when taping.

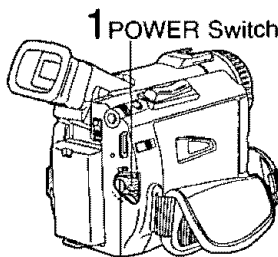

2, 3 REC/PAUSE Button

- 1 Set **POWER** to **CAMERA**.
  - The POWER Lamp lights red.
  - Be sure POWER is fully turned to CAMERA position.
- 2 In REC/PAUSE mode, hold down **EDIT SEARCH** ▶▶ to perform a forward visual search or **EDIT SEARCH** ◀◀ to perform a reverse visual search. Releasing the button stops the search.
- 3 Press **REC/PAUSE** to continue recording.

### Note

- During Edit Search, the picture will become mosaic in both ◀◀ and ▶▶ search, the sound will be muted in reverse visual search.
- Make sure the SP/LP tape speed setting is the same as the recording to eliminate distortion during edit search.

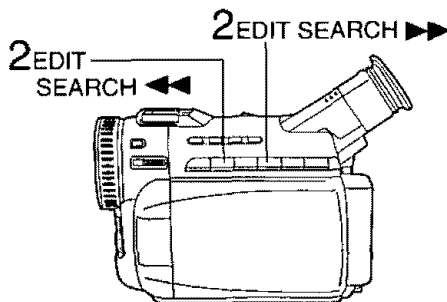



## Blank Search

You can go directly to a blank portion of tape and start recording exactly where you left off.

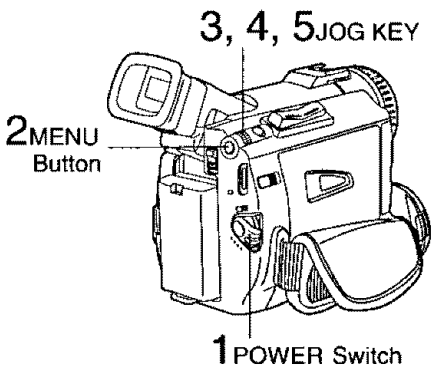

- 1** Set the **POWER** to **VCR**.
  - The **POWER** Lamp lights red.
  - Be sure **POWER** is fully turned to **VCR** position.
- 2** Press **MENU** to display the **VCR** mode menu screen.
- 3** Rotate **JOG KEY** to select **PLAY MODE**, then press **JOG KEY** to display the **VCR PLAY MODE** menu screen.
- 4** Rotate **JOG KEY** to select **B.SEARCH** in the **VCR PLAY MODE** menu. (See page 17.)
- 5** Press **JOG KEY** to select **ON**.
  - "BLANK" will appear on the screen.

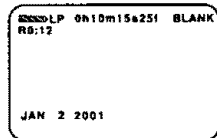

## Remote Control

You can operate the major functions of your Palmcorder from up to approximately 16 feet (5 m) away (indoors). Aim the IR Remote Control toward the front of the Palmcorder and press the desired buttons (Remote Sensor is located under the lens).

### To operate Camera functions:

Set **POWER** to **CAMERA**.

### To operate VCR functions:

Set **POWER** to **VCR**.

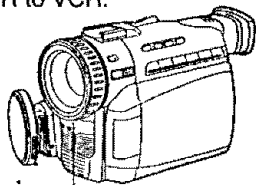

### Controlled Functions

- Rec/Pause (See page 22.)
- Tele (Zoom) (See page 22.)
- Wide (Zoom) (See page 22.)
- Date/Time (See page 20.)
- Reset (See page 50.)
- PhotoShot (See page 41.)
- Display On TV (See page 31.)
- Counter/Time Code (See page 19.)
- Audio Dubbing (See page 49.)
- Record (See pages 52, 53.)
- Menu (See page 14.)
- Play (See page 27.)
- FF/Search (See page 28.)
- REW/Search (See page 28.)
- Pause/Select (See pages 14, 28.)
- Stop/Set (See pages 14, 27.)
- Slow/Frame Advance (Forward) (See pages 28, 29.)
- Slow/Frame Advance (Backward) (See pages 28, 29.)
- Index Search (Forward) (See page 30.)
- Index Search (Backward) (See page 30.)
- Speaker Volume (See page 27.)

## Remote Controlling Two Palmcoders

You can control any two Panasonic Palmcoders with one Remote control. In order for the remote to distinguish between the two units, it is necessary to set one of the Palmcoders to VCR 2. On the remote, press VCR 1 or VCR 2 to control the desired Palmcorder.

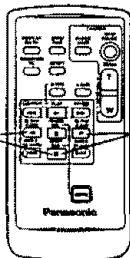

**For VCR 2 :**  
Press these buttons at the same time.

**For VCR 1 :**  
Press these buttons at the same time.

### Note

- When the Palmcorder and remote are not set to the same mode (VCR1 or VCR2), "CHECK REMOTE MODE (REMOTE)" will appear.



- 1 Set the POWER to VCR or CAMERA.**
  - The POWER Lamp lights red.
  - Be sure POWER is fully turned to VCR or CAMERA position.
- 2 Press MENU** to display the VCR or CAMERA mode menu screen.
- 3 Rotate JOG KEY** to select **CAMERA SET-UP** in the CAMERA mode menu screen or **VCR PLAY MODE** in the VCR mode menu screen, then press **JOG KEY** to display the CAMERA SET-UP or VCR PLAY MODE menu screen.
- 4 Rotate JOG KEY** to select **REMOTE**, and then press JOG KEY to select VCR 2. (See pages 16, 17). Leave the other Palmcorder set to VCR1.
- 5 Set the Remote Control to VCR 1 or VCR 2** to correspond with the Palmcorder you wish to control. (See above left.)

- After replacing the Remote Control Battery, the remote will default to VCR 1.

## Replace the Battery

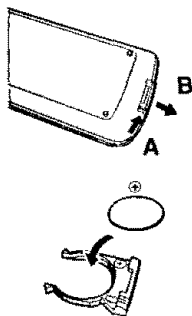

- 1** While pressing the tab in the direction of the arrow (A) with your fingernail, pull out the Battery Tray (B).
- 2** Insert the battery into the Battery Tray with the ⊕ mark facing up.  
Do not reverse the polarity.
- 3** Insert the Battery Tray.

Replace battery with Panasonic PART NO. VSBW0004 (CR2025) only. Use of another battery may present a risk of fire or explosion. Caution: battery may explode if mistreated. Dispose of used battery properly. Keep away from children. Do not recharge, disassemble or dispose of in a fire.

## Playback using the LCD Monitor

You can also use the LCD monitor to playback your recording.

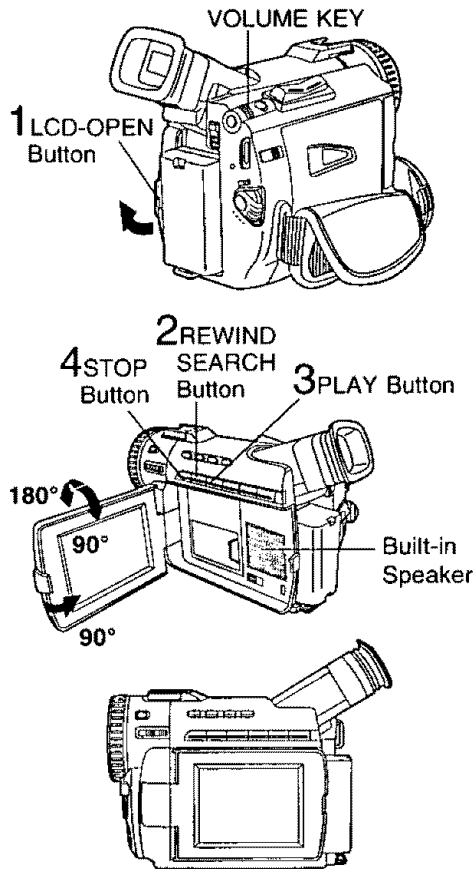

You can place the Palmcorder on a table, etc. for viewing. Rotate the LCD Monitor 180° and swing it up against the Palmcorder body as shown.

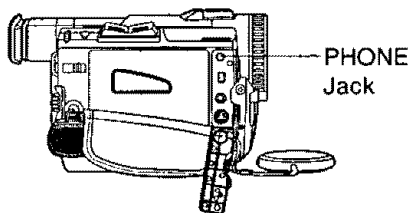

### Before you begin

- Connect the Palmcorder to a power source. (See pages 11, 12.)
- Insert a recorded cassette.
- Set POWER to VCR.

**1** Press **LCD-OPEN** to unlock the LCD monitor and swing open.

**2** Press **REWIND/SEARCH** to rewind the tape.

**3** Press **PLAY** to start playback.

### To adjust the volume:

**A** Hold down **VOLUME KEY** until the volume setting screen appears. (See page 20).

**B** Rotate **VOLUME KEY** to adjust the volume of the built-in speaker. To remove the volume setting screen, hold down **VOLUME KEY** again.

• Adjust the picture on the LCD monitor if needed. (See page 23.)

**4** Press **STOP** to stop playback.

- When the tape reaches its beginning during rewind or rewind search, it will stop automatically.
- If you press **PLAY** for more than 5 seconds, the Palmcorder will go into Repeat Playback mode when the tape reaches its end. The letter "R ▷" will appear in the EVF and LCD monitor. To exit the Repeat Playback mode, turn the Palmcorder OFF.

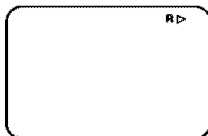

### Note

- When a tape recorded in LP mode on another digital video camera is played back on this unit, the picture may appear mosaic.
- Using the LCD monitor reduces battery operating time.
- You can connect earphones (not supplied) to the PHONE Jack.

## Special Effect Features During Playback

### Note

- Sound is muted during all special effects.

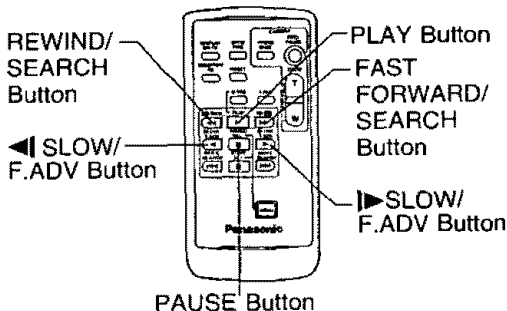
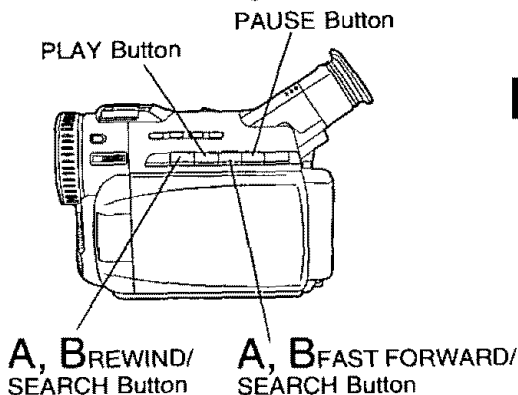

## Fast Forward/Rewind Check

Monitor normal picture playback during fast forward or rewind.

- Hold down **FAST FORWARD/SEARCH** during fast forward.
- Hold down **REWIND/SEARCH** during rewind.
- The picture will appear for as long as the button is held down.

## Rapid Visual Search

**A** During playback, hold down **FAST FORWARD/SEARCH** or **REWIND/SEARCH**.

The search will continue for as long as the button is held down.

OR

**B** Press **FAST FORWARD/SEARCH** or **REWIND/SEARCH** once for a continuous rapid visual search. Press **PLAY** to release.

### Note

- When executing a rapid visual search, the picture may become bluish for an instant or mosaic. This is normal during this mode.

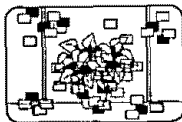

## STILL Picture

Press **PAUSE** during playback.

Press **PLAY** or **PAUSE** to release.

### Note

- To protect the tape and video heads, your Palmcorder's operating modes will revert as follows:  
STILL → STOP (after 3 minutes.)

## Slow Motion Playback

(Remote Control Only)

Forward Slow = Press **▶ SLOW/F.ADV** during play.

Reverse Slow = Press **◀ SLOW/F.ADV** during play.

Press **PLAY** to release. (During reverse slow motion playback, time code indication may not change regularly.)

### Note

- Palmcorder will automatically STOP when in slow motion for more than 10 minutes.
- During slow motion playback, picture may move up and down. This is normal.
- When you start or stop slow motion playback, the picture may become bluish for an instant.

## Special Effect Features During Playback (Continued)

### Note

- Sound is muted during all special effects.

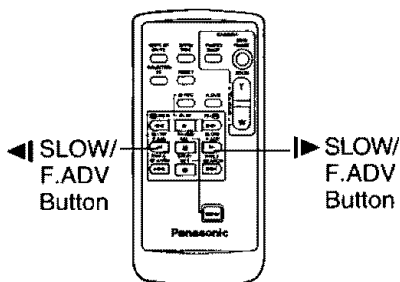
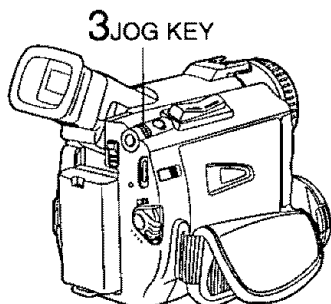
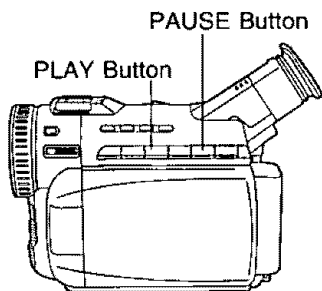

## Variable Speed Search

- 1 Press **PLAY** to start playback.
- 2 Press **PLAY** again.
- 3 Rotate **JOG KEY** to adjust the playback speed.
  - Rotate **JOG KEY** downward for forward playback.
  - Rotate **JOG KEY** upward for reverse playback.

### To return to normal playback:

Press **PLAY**. Playback will continue at normal speed.

### Note

- The Variable Speed Search function offers a choice of six playback speeds (1/5X, 1X, 2X, 5X, 10X, 20X) both in forward and reverse directions.
- The review playback at the 1X speed is playback in reverse direction.
- During the Variable Speed Search (at a speed other than 1X), mosaic-like patterns will appear in the picture.
- During the Variable Speed Search, sound is muted.

## Jog Frame by Frame Search

### (Palmcorder only)

During Still mode, rotate **JOG KEY** to advance or reverse the picture one frame at a time.

## Frame by Frame Advance

### (Remote Control Only)

Press **PAUSE** during playback.

Press **▶ SLOW/F.ADV** to do a frame by frame advance.

Press **◀ SLOW/F.ADV** to do a frame by frame reverse.

Press **PLAY** to release.

### Note

- If you hold down **SLOW/F.ADV**, you can see a continuous series of still images at a slower speed than normal slow mode.
- During frame by frame advance, a few frames may move automatically, and the picture may become bluish for an instant.

## Special Effect Features During Playback (Continued)

### Note

- Sound is muted during all special effects.

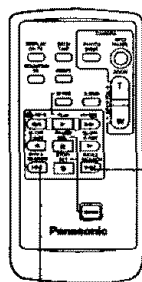
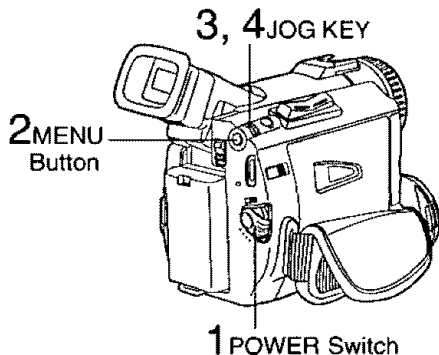

B INDEX SEARCH (rewind) Button

### Top Scan

If you hold down INDEX SEARCH more than 2 seconds, the Palmcorder will scan for scenes (or PhotoShots) and playback the first few seconds of each.

To cancel this function, press PLAY or STOP.

### Note

- Search will not work if there is succession of PhotoShots.

## Index Forward/Reverse Search

### (Remote Control Only)

Search for a particular scene by using the electronic index marks placed at the beginning of each recording.

- 1** Set the **POWER** to **VCR**.
  - The **POWER** lamp lights red.
  - Be sure **POWER** is fully turned to **VCR** position.
- 2** Press **MENU** to display the **VCR** mode menu screen.
- 3** Rotate **JOG KEY** to select **PLAY MODE**, then press **JOG KEY** to display the **VCR PLAY MODE** menu screen.
- 4** Rotate **JOG KEY** to select **INDEX**, and then press **JOG KEY** to select **PHOTO** or **SCENE**. (See page 17.)

- A** Place the Palmcorder in the **VCR STOP** mode.
- B** Press **INDEX SEARCH** fast forward or rewind for the number of recordings (indexes) forward or back you want to view. The Palmcorder will advance or rewind to the desired recording and automatically start playback.
  - The number of times you pressed the button is displayed in the EVF and the LCD monitor if you set **INDEX** on the **VCR** menu to **SCENE**. (See page 17.) (Ex., if you press the button three times, "S3" will appear.)
  - If the interval between scenes is less than 1 minute, index search may not operate properly.
  - Response time from pressing the button and the change in the scene number is quite slow. Do not press **INDEX SEARCH** rapidly and continuously.
  - During **Reverse Index Search** mode, playback will not begin when a tape rewinds all the way to the beginning.

# View Recording/Playback on your TV

## [ TV with AUDIO/VIDEO IN Jacks ]

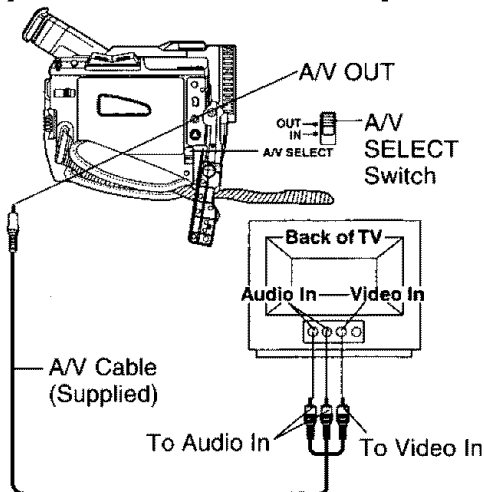

## [ TV with S-VIDEO IN Jacks ]

For best Chrominance and Luminance, use the S-Video connection if available on your TV.

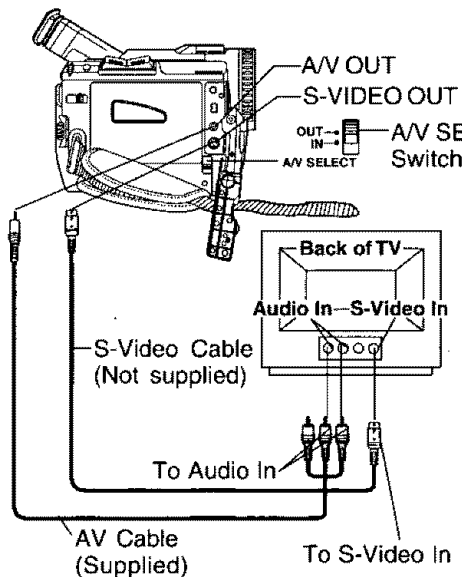

- 1** Set **POWER** to **CAMERA** or **VCR**.  
To view what the Palmcorder is recording or to playback a tape on your TV.
- 2** Set **AV SELECT** to **OUT**.
- 3** Turn your TV **ON** and set it to **LINE INPUT** or **S-VIDEO**.  
Check your TV operating instructions for further information.
- 4** Start playback or begin a recording.

### Note

- Make sure the Palmcorder and TV are turned off while connecting.
- Please connect the A/V Cable securely.

### (Remote Control Only)

You can display the various EVF and LCD indications on your TV by pressing **DISPLAY ON TV** on remote control. Press again to remove the indications.

DISPLAY ON TV Button

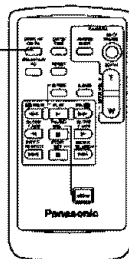

### CATV System Installer

This reminder is provided to call the CATV system installer's attention to Article 820-40 of the NEC in USA (and to the Canadian Electrical code in Canada) that provides guidelines for proper grounding and, in particular, specifies that the cable ground shall be connected to the grounding system of the building, as close to the point of cable entry as practical.

## Card PhotoShot

You can record still images to a Memory Card.

### Warning

- Memory Card will not work when DV interface Cable (i.LINK) is connected.

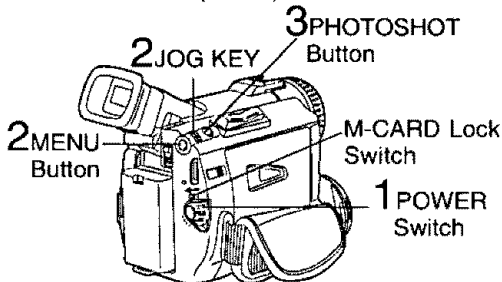

## Image Resolution and Capacity (supplied 8MB MultiMediaCard)

REC Mode	Image Resolution	Capacity
FINE	640 x 480	Approx. 60 images
NORMAL	320 x 240	Approx. 240 images

- The number of images given for each mode applies when all images are taken in same mode.
- You can change recording modes at any time before capturing an image.
- The number of images that can be captured may differ depending on the subject. After capturing an image, the number may not decrease, or it may decrease by two. This is normal.

### Warning

- While "PROCESSING" is displayed, **DO NOT turn off the Palmcorder or unplug the AC Adaptor** (supplied) because this will cause irreversible damage to the memory.

## Cautions for the Memory Card

- While Memory Card data is being read, do not remove it, turn off the power, or subject unit to vibrations and shocks.
- Do not leave the Memory Card in a place with high temperature, exposed to direct sunlight, or where electromagnetic waves and static electricity can be generated.
- Electromagnetic waves, static electricity, malfunction of the Digital Video Palmcorder or of the Memory Card itself could erase the data recorded on it. To prevent the loss of picture data, we recommend that you make a backup copy on the computer.
- Do not bend or drop the Memory Card as this could damage it or the captured contents.
- Do not touch the connector on the rear edge of the Memory Card with your fingers and take care that no dirt, dust or water enters it.
- Do not affix other labels to the Memory Card face or back as Card insertion/removal may become impossible.

## Before you begin

- Connect the Palmcorder to a power source. (See pages 11, 12.)
- Set POWER to OFF before inserting a Memory Card. (See page 10.)

- 1 Slide the M-CARD Lock Switch to unlock, then set POWER to M-CARD.
  - The POWER lamp lights red.
  - Be sure POWER is fully turned to M-CARD position.
  - "PLAY: PUSH PLAY KEY" is displayed for 10 seconds. (See page 33.)
- 2 Press MENU to display CARD SETTING menu, then press JOG KEY to select **NORMAL** or **FINE**.

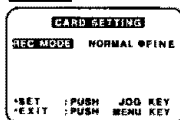

- 3 Press MENU to exit this menu.
- 3 Press PHOTOSHOT to record an image.

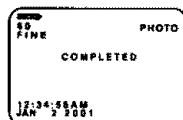
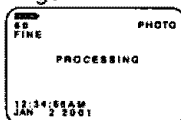

- The PhotoShot image is recorded to the Memory Card.
- When SHUTTER is set to ON (see page 15), still pictures are recorded with a visual shutter effect and click sound. If set to OFF, the still image will be displayed only.



## Recording images From a Tape

You can record still images from a cassette tape to a Memory Card.

### Warning

- Memory Card will not work when DV interface Cable (i.LINK) is connected.

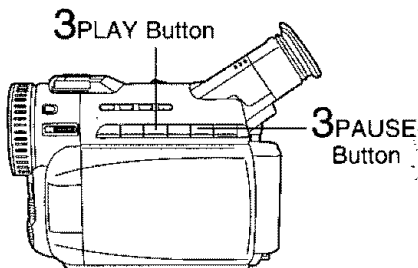
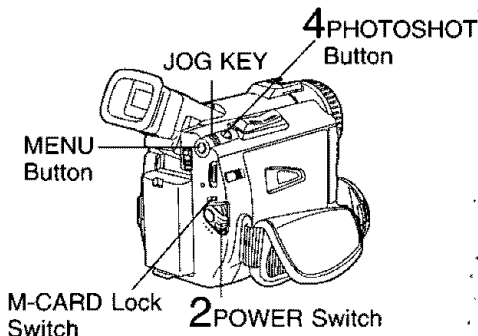

## Playback Still Images

You can view the images on the Memory Card.

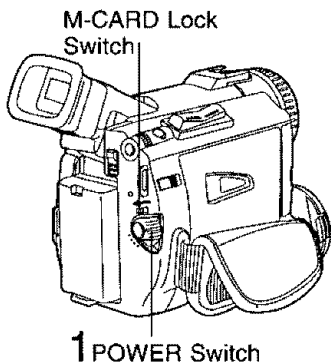

## Before you begin

- Connect the Palmcorder to a power source. (See pages 11, 12.)
- Set POWER to OFF before inserting a Memory Card. (See page 10.)

- 1 Repeat steps 1 and 2 on page 32.
- 2 Set POWER to VCR.
  - The POWER lamp lights red.
  - Be sure POWER is fully turned to VCR position.
- 3 Press PLAY to start playback of the cassette tape. And then, press PAUSE to select an image.
- 4 Press PHOTOSHOT to record the desired image to the Memory Card.

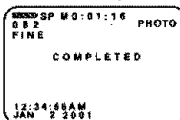
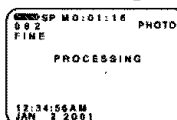

- When PHOTOSHOT is pressed in PLAY or SLOW mode, the screen goes to STOP mode.
- To playback the images of the Memory Card, see pages 33-34.
- When Variable Speed Search is done (see page 29), this feature can not be used.

- 5 Repeat steps 3-4 to record another image to the Memory Card.

## Before you begin

- Connect the Palmcorder to a power source. (See pages 11, 12.)
- Set POWER to OFF before inserting a recorded Memory Card. (See pages 32, 33.)

- 1 Slide the M-CARD Lock Switch to unlock, then set POWER to M-CARD.
  - The POWER lamp lights red.
  - Be sure POWER is fully turned to M-CARD position.
  - "PLAY: PUSH PLAY KEY" is displayed for 10 seconds.

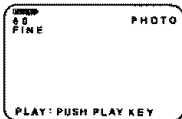

(Continued on next page.)

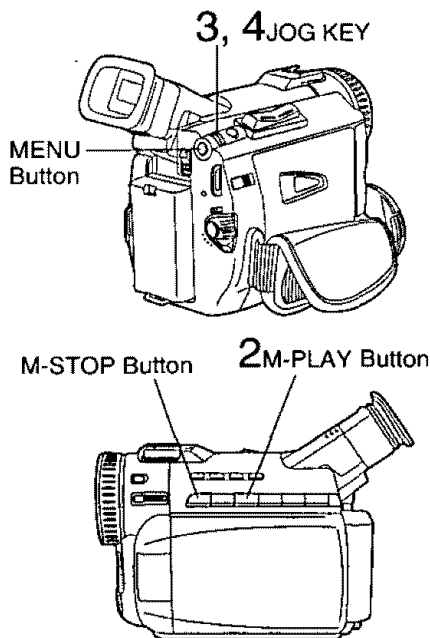

- 2** Press **M-PLAY** to display the Multi playback screen.
- "PLEASE WAIT" appears on-screen.
  - Rotate **JOG KEY** to scroll through Multi image screen pages (6 images per page) and select an image.
  - The selected image is underlined in green.

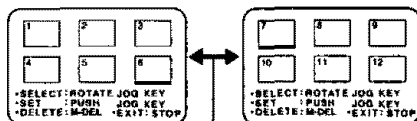

"PLEASE WAIT" is displayed.

- Press **MENU** to display **CARD SETTING** menu screen.
- Press **M-STOP** to return to the Card PhotoShot REC Mode. (See page 32.)

- 3** Press **JOG KEY** to display the selected image as a full-size screen.
- "PLEASE WAIT" appears on-screen.

- 4** Rotate **JOG KEY** to select **BACK** (previous image), **MULTI** (Multi Image screen), or **NEXT** (next image).

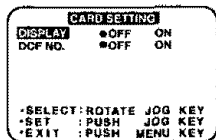

**DISPLAY** : Select OFF to remove all displays from the screen.

**DCF (Design rule for Camera File system)**

: Select OFF to cancel DCF No. on the screen.

#### Note

- If the file number is changed, the Palmcorder cannot read the file data.
- This product is compliant with DCF (Design rule for Camera File System). Images saved on the Memory Card using other Digital Still Cameras that are compliant with DCF can be viewed on this product.

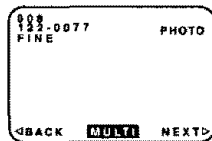

- Press **M-STOP** to return to the Multi Playback screen.

#### Warning

- While "PLEASE WAIT" is displayed, **DO NOT** turn off the Palmcorder or unplug the **AC Adaptor (supplied)** because this will cause irreversible damage to the memory.

## Delete Specific Images

You can delete unwanted images and increase the remaining image memory.

### Warning:

Once deleted, images cannot be restored.

### DELETE PAGE

Delete specific images from a page.

### DELETE ALL

Delete all images. (See page 36.)

### FORMAT

Delete all data. (See page 37.)

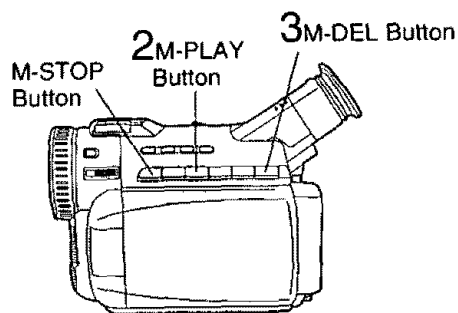
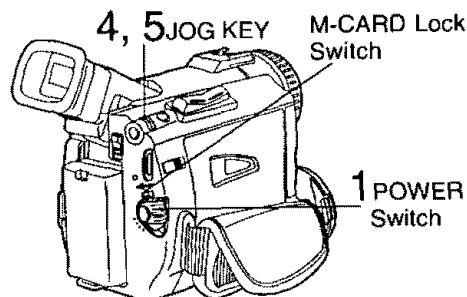

## Before you begin

- Connect the Palmcorder to a power source. (See pages 11, 12.)
- Set POWER to OFF before inserting a recorded Memory Card. (See pages 32, 33.)

- 1 Slide the M-CARD Lock Switch to **unlock**, then set POWER to M-CARD.
  - The POWER lamp lights red.
  - Be sure POWER is fully turned to M-CARD position.
  - "PLAY: PUSH PLAY KEY" is displayed for 10 seconds.

- 2 Press M-PLAY to display the Multi playback screen.
  - "PLEASE WAIT" appears on-screen.

- 3 Press M-DEL to display the DELETE menu, then rotate and press JOG KEY to select **PAGE**.

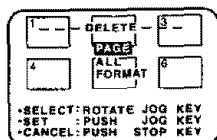

- DELETE PAGE menu is displayed.

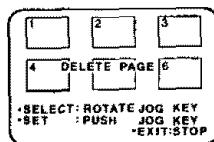

- 4 Rotate and press JOG KEY to select and set the image to be deleted.
  - The selected image is underlined in pink.

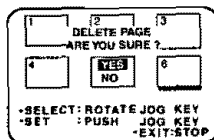

- 5 Rotate JOG KEY to select **YES**, and press JOG KEY to delete the selected image.
  - To cancel delete, press M-STOP or rotate and press JOG KEY to select NO.
  - "PLEASE WAIT" appears on-screen.
  - To delete other images, repeat steps 4-5.

### Warning

- While deleting image, **DO NOT** turn off the Palmcorder or unplug the AC Adaptor (supplied) because this will cause irreversible damage to the memory, resulting in reduced image storage capacity.

## Delete All Image Pages

You can delete all images from the Memory Card easily with this operation.

### Warning:

Once deleted, images cannot be restored.

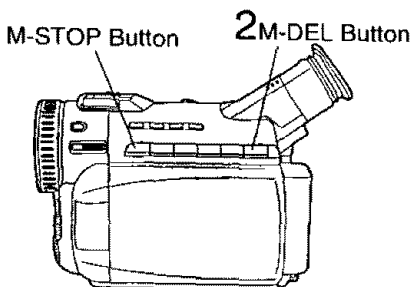
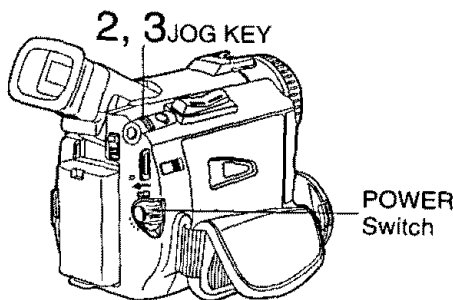

## Before you begin

- Connect the Palmcorder to a power source. (See pages 11, 12.)
- Set POWER to OFF before inserting a recorded Memory Card. (See pages 32, 33.)

**1** Do steps 1 and 2 on page 35.

**2** Press M-DEL to display the DELETE menu. Then, rotate and press JOG KEY to select **ALL**.

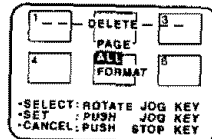

- The screen below is displayed.
- To cancel delete, press M-STOP or rotate and press JOG KEY to select NO.

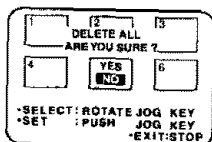

**3** Rotate and press JOG KEY to select **YES**.

- "PLEASE WAIT" is displayed on the screen, and then "NO PICTURE" is displayed.

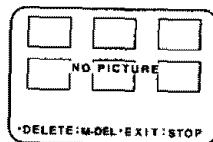

- Press M-STOP to return to the Card PhotoShot REC Mode screen. (See page 32.)

### Warning

- While deleting image, **DO NOT** turn off the Digital Video Camcorder or unplug the AC Adaptor (supplied) because this will cause irreversible damage to the memory, resulting in reduced image storage capacity.

## Format the Memory Card

You can easily format your Memory Card using this operation.

### Warning:

Formatting permanently removes all image data.

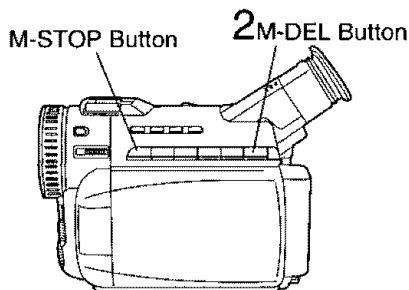
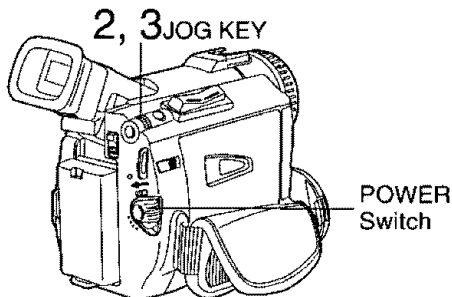

### Warning

- While deleting image, **DO NOT** turn off the Palmcorder or unplug the AC Adaptor (supplied) because this will cause irreversible damage to the memory, resulting in reduced image storage capacity.

## Before you begin

- Connect the Palmcorder to a power source. (See pages 11, 12.)
- Set POWER to OFF before inserting a recorded Memory Card. (See pages 32, 33.)

**1** Do steps 1 and 2 on page 35.

**2** Press M-DEL to display the DELETE menu, then rotate and press JOG KEY to select **FORMAT**.

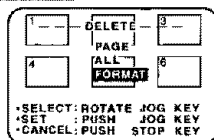

- The screen below is displayed.
- To cancel format, press M-STOP or rotate and press JOG KEY to select NO.

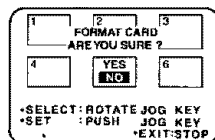

**3** Rotate and press JOG KEY to select **YES**.

- "PLEASE WAIT" is displayed on the screen as all image data is deleted from memory card. Deletion is complete when "NO PICTURE" is displayed.

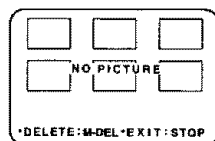

- Press M-STOP to return to the Card PhotoShot REC Mode screen. (See page 32).

## Photo Title

You can record PhotoShot images from a Memory Card to a cassette to be used as a WIPE or MIX effect.

### Note

When Photo Title is set to ON, the selected image and Title will appear before each recording is made.

**WIPE** : The Photo title is replaced with the current scene in a wiping motion.



**MIX** : The photo title is replaced with the current scene in a gradual mixing effect.

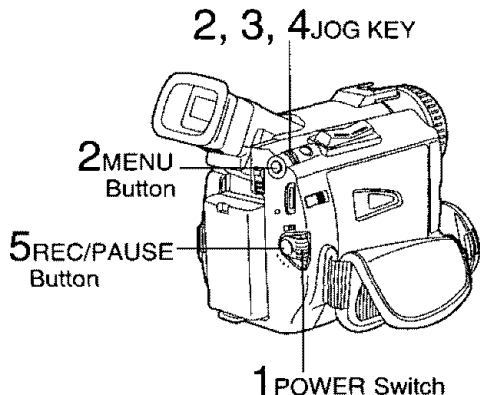

## Before you begin

- Connect the Palmcorder to a power source. (See pages 11, 12.)
- Set POWER to OFF before inserting a recorded Memory Card. (See pages 32, 33.)

- 1 Set POWER to CAMERA.**
  - The POWER lamp lights red.
  - Be sure POWER is fully turned to CAMERA position.
- 2 Press MENU to display the CAMERA menu screen. Then rotate and press JOG KEY to select PHOTO TITLE.**



- 3 Rotate and press JOG KEY to select and set MODE and then TITLE.**  
1st : Select and set MODE (WIPE or MIX).  
2nd : Select and set TITLE to "SET".



- "PLEASE WAIT" appears on-screen.
- The Multi image screen is displayed.

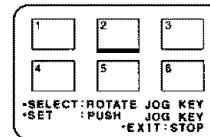

- 4 Rotate and press JOG KEY to select and set an image.**
  - "PLEASE WAIT" is displayed while image is processed. Then, "PHOTO TITLE SET" is displayed for approx. 3 seconds, and the screen goes back to the Camera mode screen.
  - After Photo Title is performed, Digital Function turns off.
  - There are 12 pre-installed files.
- 5 Press REC/PAUSE to start recording with Photo Title.**
  - WIPE or MIX screen is displayed at beginning of the recording. Then the Photo Title setting will be cleared automatically.

## Dual Digital Electronic Image Stabilization System (D.E.I.S.)

This feature helps compensate for any unintentional hand or body movement. It can be used in both the Recording and Playback (VCR) modes.

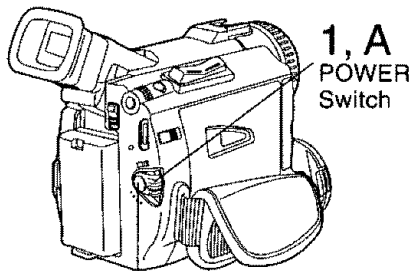
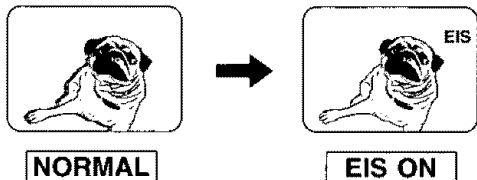

3 REC/PAUSE Button

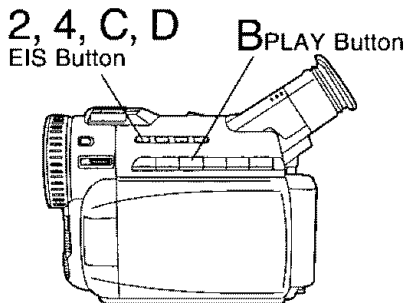

### Note

- Other Digital Functions are turned off automatically when the EIS and Digital Zoom are selected.

## CAMERA mode

- 1 Set **POWER** to **CAMERA**.
  - The **POWER** lamp lights red.
  - Be sure **POWER** is fully turned to **CAMERA** position.
- 2 Press **EIS** to stabilize the picture.
  - Picture flicker may be observed when taping under fluorescent lighting conditions.
  - The **EIS** indicator flashes when the light level is inadequate.
  - Turn **D.E.I.S.** **OFF** during recording when using a tripod.
- 3 Press **REC/PAUSE** to start recording.
- 4 Press **EIS** again to cancel.
  - Be sure that **D.E.I.S.** is turned off when not needed.

### D.E.I.S. may not function when...

- Palmcorder movement is too extreme.
- Recording a subject with distinct horizontal or vertical stripes.
- Recording in low light situations.
- Recording a subject under a great amount of fluorescent light.
- Recording a scene with very fast motions.

## VCR mode

- A** Set **POWER** to **VCR**.
  - The **POWER** lamp lights red.
  - Be sure **POWER** is fully turned to **VCR** position.
- B** Press **PLAY** to start playback.
- C** Press **EIS** to stabilize the picture.
- D** Press **EIS** again to cancel.
  - Be sure that **D.E.I.S.** is turned off when not needed.

### Note

- When using **D.E.I.S.** in **VCR** mode, the image size is slightly larger.

## Digital Zoom

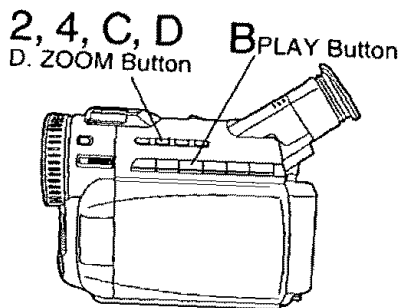
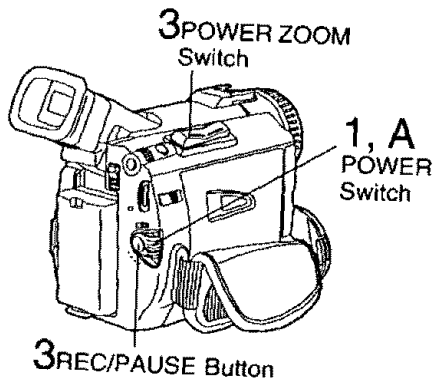

Zoom In ("T")

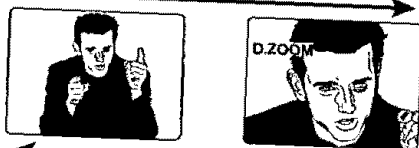

Zoom Out ("W")

### Note

- Other Digital Functions are turned off automatically when the EIS and Digital Zoom are selected.

## CAMERA mode

- 1** Set **POWER** to **CAMERA**.
  - The **POWER** lamp lights red.
  - Be sure **POWER** is fully turned to **CAMERA** position.
- 2** Press **D. ZOOM** to select **D.ZOOM1** or **D.ZOOM2**.
  - once : **D.ZOOM1** (from 20X to 40X)
  - twice : **D.ZOOM2** (from 20X to 300X)
  - three times : Turn off **D.ZOOM**
- 3** Press **REC/PAUSE** to start recording and press **POWER ZOOM** to zoom in or zoom out.
  - The magnification level is always displayed in the EVF or the LCD monitor when **DISPLAY** is set to **ON**. (See pages 16, 18.)
- 4** Press **D.ZOOM** to turn off Digital Zoom so that no indication appears.

### Note

- The normal optical zoom functions from 1X to 20X.
- Because the image is enlarged digitally, the picture may become distorted when higher magnification levels are used.
- When the level falls below 20X, the normal zooming function will resume.
- Focus distance becomes 4 feet (1.2 m) if the lens is in full telephoto.

## VCR mode

- A** Set **POWER** to **VCR**.
  - The **POWER** lamp lights red.
  - Be sure **POWER** is fully turned to **VCR** position.
- B** Press **PLAY** to start playback.
- C** Press **D.ZOOM**.
  - The center portion of the image doubles in size.
- D** Press **D.ZOOM** again for normal image size.



## Digital PhotoShot

Use this feature to record a seven second (approx.) still image from the current camera picture. Audio is also recorded for on-the-spot narration. Or, you can add narration later with the Audio Dubbing feature to make an interesting slide show, etc. (See page 49.)

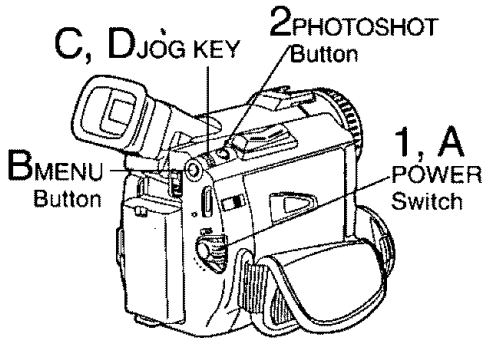

- 1 Set POWER to CAMERA.**
  - The POWER lamp lights red.
  - Be sure POWER is fully turned to CAMERA position.
- 2 Press PHOTOSHOT in Record/Pause mode.** "PHOTO" will appear in the EVF or the LCD monitor.



- If SHUTTER on the menu screen is set to ON, a sound effect similar to the shutter of a film camera will be heard when PHOTOSHOT is pressed.
- When PHOTOSHOT is pressed, the playback image takes approx. 7 seconds to process. After that, the Camera mode screen will be displayed.

## Index Search (Photo/Scene)

(Remote Control Only)

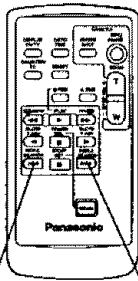

**E INDEX SEARCH**  
(rewind Button)

**E INDEX SEARCH**  
(fast forward Button)

### Note

- The picture quality will deteriorate slightly.
- The tape remaining indicator will not appear while the PHOTOSHOT feature is used.
- In the Photo/Scene Index Search mode, the shutter sound effect may not be able to be heard even when SHUTTER is set to ON.
- Photo Index Search may fail to detect a recorded PhotoShot image if the image is 3 seconds or less.

- A Set POWER to VCR.**
  - The POWER lamp lights red.
  - Be sure POWER is fully turned to VCR position.
- B Press MENU** to display the VCR mode menu screen.
- C Rotate JOG KEY** to select **PLAY MODE**, and **press JOG KEY** to display the VCR PLAY MODE menu screen.
- D Rotate JOG KEY** to select **INDEX**, and **press JOG KEY** to select PHOTO or SCENE.
  - Press MENU twice to exit.
- E Press INDEX SEARCH fast forward or rewind** on the remote control to advance or rewind the tape to playback a PhotoShot scene. To view the next PhotoShot, INDEX SEARCH must be pressed again.

## White Balance

Auto White Balance automatically maintains optimum color balance in most lighting conditions. However, when using Digital Functions, etc., you may get better results using the manual adjustment.

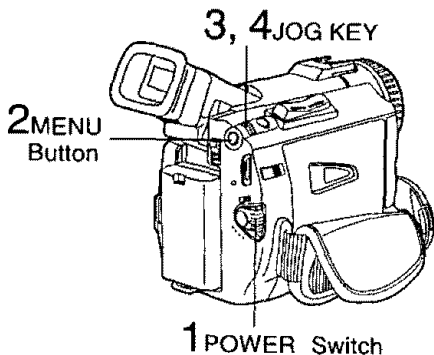

## Recording Still Pictures

You can record still pictures of any desired duration together with sound.

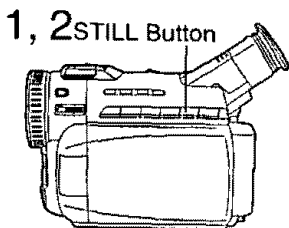

## MAGICVU/OLUX

MAGICVU allows you to record subjects in comparatively dark places.

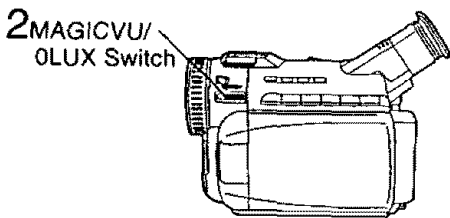

- 1 Set **POWER** to **CAMERA**.
  - The **POWER** lamp lights red.
  - Be sure **POWER** is fully turned to **CAMERA** position.
- 2 Press **MENU** to display the menu screen.
- 3 Rotate **JOG KEY** to select **ADJUST**, and then press **JOG KEY** to display the **CAMERA ADJUST** menu screen.
- 4 Rotate **JOG KEY** to select **W.BALANCE**, and then press **JOG KEY** repeatedly to select **AUTO**, **Indoor halogen lamp** "☼", or **Outdoors** "☀".

☼ : When the source illumination is a halogen lamp.

☀ : When shooting outdoors on a sunny day.

**AUTO** : Automatically maintains optimum color balance in most lighting conditions.

- 1 While in **RECORD** mode, press **STILL** and hold for **2 seconds** to capture a still picture. The captured still picture will be recorded together with sound.
- 2 Press **STILL** once again to release the still picture. The camera will resume recording real-time pictures.

- 1 Set **POWER** to **CAMERA**.
  - The **POWER** lamp lights red.
  - Be sure **POWER** is fully turned to **CAMERA** position.
- 2 Slide **MAGICVU/OLUX** to **ON**.
  - A black and white image appears.
  - You can select the color of image: **B/W**, **green**, or **blue**. (See page 16.)
  - To cancel this feature, slide **MAGICVU/OLUX** to **OFF**.

### Note

- The subject can be up to 3 m (9 feet) away.

## Program AE

The Auto Exposure feature can be used to make quality recordings in a variety of scene situations.

### Note

- When MAGICVU is ON, Program AE and H.S.S. cannot be set in the menu.

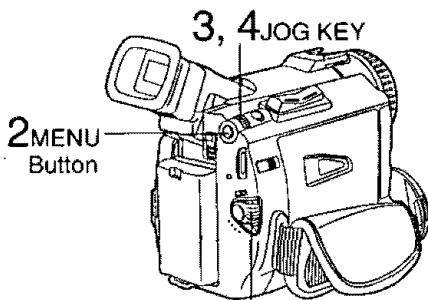

1 POWER Switch

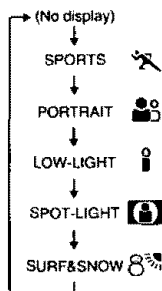

### Note

#### SPORTS mode

- The recorded images will not be so blurred when they are viewed later using slow or still picture playback.
- When playing back a sports mode recording, the movement may appear slightly jerky.
- Do not use this mode when recording under fluorescent, mercury, or sodium lighting. These types of lights will affect the color and brightness of the images.
- A vertical band of light might appear when recording objects that are brightly illuminated or which are highly reflective.
- If the amount of light is insufficient, the SPORTS "X" indicator will flash in the EVF or the LCD monitor.
- The image may flicker if this mode is used indoors.

- 1 Set **POWER** to **CAMERA**.
  - The **POWER** lamp lights red.
  - Be sure **POWER** is fully turned to **CAMERA** position.
- 2 Press **MENU** to display the menu screen.
- 3 Rotate **JOG KEY** to select **ADJUST**, and then press **JOG KEY** to display the **CAMERA ADJUST** menu screen.
- 4 Rotate **JOG KEY** to select **PROG.AE**, then press **JOG KEY** repeatedly to select one of the five modes shown below.
- 5 Repeat steps 2-4 to select **OFF** to cancel this feature.

Mode	Indication
	For recording fast action scenes.
	For recording only subjects in the foreground, while ignoring subjects in the background.
	For recording in extreme low light conditions.
	Recording in situations where subjects are under a spotlight(s).
	For recording in locations with a high degree of "Dazzle," such as snow slopes and the seashore.

#### PORTRAIT mode

- The image may flicker if this mode is used indoors.

#### LOW-LIGHT mode

- Scenes recorded in extremely low light levels may not come out properly.

#### SPOT-LIGHT mode

- If the recorded subject is extremely bright, the picture may appear whitish.

#### SURF&SNOW mode

- If the recorded subject is extremely bright, the picture may appear whitish.
- It is not possible to select the SPORTS mode or PORTRAIT mode together with the GAIN UP in the Digital function camera menu.

## Other Digital Functions

Use the following features to add interest and professionalism to your recordings or playback. Select from twelve special effects.

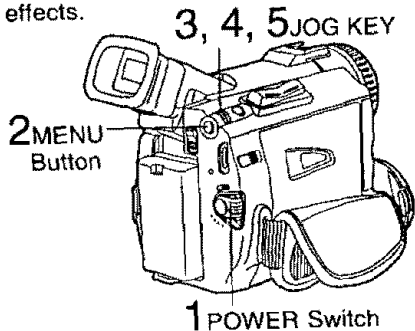

## Types of Digital Functions

### MIRROR

Symmetrical image from the current camera picture.

### STROBE

The recording appears as a sequence of still frames.

### MOSAIC

The picture appears in a mosaic pattern.

### SLIM

The picture is expanded vertically.

### TRAIL

The subject being recorded creates a trail when in motion.

### STRETCH

The picture is expanded horizontally.

### GAIN UP (Not available during playback)

Picture sensitivity is increased.

• Only Manual Focus is available.

### WIPE

Successive scenes are separated in a way which simulates the drawing of a curtain.

### MIX

The current scene is mixed in with the following scene during scene changes.

### PinP

PinP (Still image) is displayed on the Main Picture.

### SEPIA (Only available during playback)

The picture is played back in sepia, a brownish color, giving it an antique look.

### MONO (Monotone) (Only available during playback)

The picture is played back in black-and-white.

**1** Set **POWER** to **CAMERA** or **VCR**.  
• The **POWER** lamp lights red.  
• Be sure **POWER** is fully turned to **CAMERA** or **VCR** position.

**2** Press **MENU** to display the menu screen.

**3** Rotate **JOG KEY** to select **D.FUNCTION** in the **CAMERA** mode menu screen or **PLAY FUNCTION** in the **VCR** mode menu screen, then press **JOG KEY** to display the **CAMERA FUNCTION** or **VCR PLAY FUNCTION** menu screen.

**4** Rotate **JOG KEY** to select **D.FUNCTION**, and then press **JOG KEY** repeatedly to select one of the Digital Functions listed on the left.

**5** To cancel the Digital Function, press **JOG KEY** repeatedly to select **OFF**.

### Note

- The **EIS** and **Digital Zoom** features are turned off automatically when one of the Digital Functions listed at left is selected.

### To use the WIPE function

- a. In Camera mode, set the "D.FUNCTION" item in the main menu screen to "WIPE". (See page 15.)
- b. Press **REC/PAUSE** to start recording.
- c. Press **REC/PAUSE** to pause the recording. The last scene will be memorized.
- d. Press **RECORD/PAUSE** to start recording again. The new scene will take the place of the memorized scene.

### To use the MIX function

- a. In Camera mode, set the "D.FUNCTION" item in the main menu screen to "MIX" (see page 15). Then, perform steps b-d above.

The memorized scene and the new scene will appear mixed as the scene changes from one to the other.

### Note

- When **Photo Title** is set, **WIPE/MIX** mode becomes **Photo Title**. When **Photo Title** is finished, Digital Function turns **OFF**.

## Picture in Picture (PinP)

You can display a PinP (still image) screen on the Main Picture.

### Note

- PinP position is fixed at the bottom right of the screen.

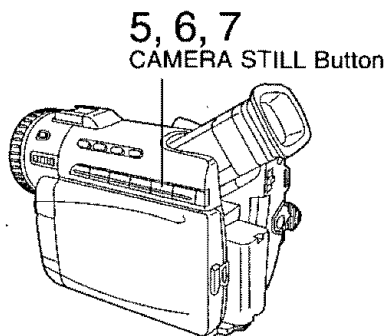
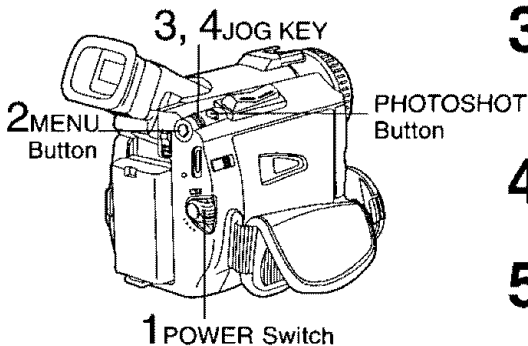
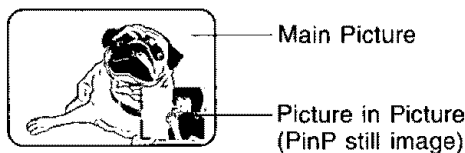

## Before you begin

- Connect the Palmcorder to a power source. (See pages 11, 12.)

- 1 Set POWER to CAMERA.**
  - The POWER lamp lights red.
  - Be sure POWER is fully turned to CAMERA position.
- 2 Press MENU** to display the menu screen.
- 3 Rotate JOG KEY repeatedly** to select **D.FUNCTION**, then **press JOG KEY** to display the CAMERA FUNCTION menu screen.
- 4 Press JOG KEY** to select **PinP**.
  - Press MENU twice to exit this menu.
- 5 Aim at the scene you wish to place as PinP**, then **press CAMERA STILL** to freeze the image.
- 6 Press CAMERA STILL again** to place the frozen image as PinP.
- 7 Press REC/PAUSE** to record a scene with PinP image.
  - Press PHOTOSHOT to record a scene with PinP image in PhotoShot mode.
  - Press CAMERA STILL again to remove PinP image.



## Strobe Multi Mode

In Strobe Multi Mode, you can select the rate at which a succession of still screens are captured from the playback picture.

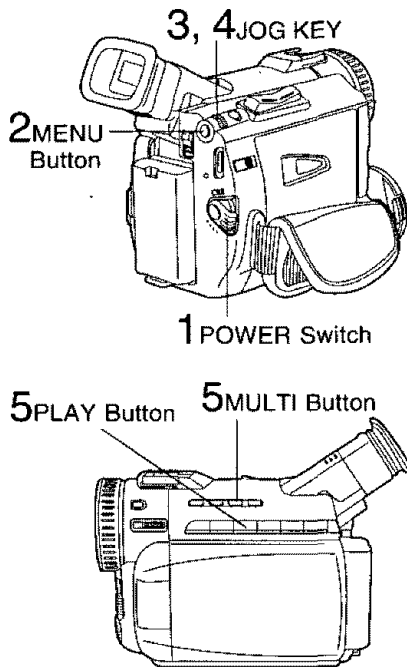

### Note

- A Multi Image Playback screen cannot be output from the DV terminal or Digital Still Image terminal.
- A Multi screen will have slightly lower image quality.

## Before you begin

- Connect the Palmcorder to a power source. (See pages 11, 12.)

- 1** Set **POWER** to **VCR**.
  - The **POWER** lamp lights red.
  - Be sure **POWER** is fully turned to **VCR** position.
- 2** Press **MENU** to display the menu screen.
- 3** Rotate and press **JOG KEY** to select and set **MULTI SETTING**.
- 4** Press **JOG KEY** to select **SPEED**, then press repeatedly to set desired speed.

### Strobe Speeds

Strobe Speeds	9 screen capture time
<b>FAST</b>	Every 0.3 seconds
<b>NORM</b>	Every 0.6 seconds
<b>SLOW</b>	Every 1.0 seconds

- Press **MENU** twice to exit.

- 5** Press **PLAY** to start playback. Press **MULTI** at the point you want to start capturing.
  - A succession of 9 screens will be captured, and playback will stop.

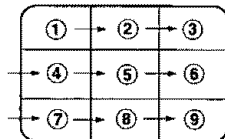

- Press **MULTI** to return to the normal **STILL** screen.  
Press **PLAY** to start playback.  
Press **STOP** to stop playback.

## Auto Focus

The Palmcorder automatically adjusts the focus over the entire zoom range.

## Manual Focus

Use Manual Focus (MF) when recording ...

- a subject through glass.
  - a scene where the subject is far from the Palmcorder and there are objects in the foreground.
  - a subject with distinct horizontal stripes.
  - a subject not centered in the Viewfinder.
  - subjects with shiny surfaces.
  - an obliquely angled subject.
  - a bright, flat subject such as a white wall.
  - in low light situations.
  - a scene with fast motions, like a golf swing.
- Re-focusing may be required**
- when your Palmcorder is aimed at a new scene.

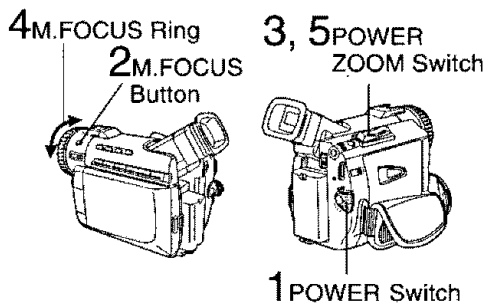

- 1 Set POWER to CAMERA.**
  - The POWER lamp lights red.
  - Be sure POWER is fully turned to CAMERA position.
- 2 Press M.FOCUS** so that "MF" (Manual Focus) appears in the EVF or the LCD monitor.
- 3 Press and hold POWER ZOOM "T" side (Telephoto)** until the lens is at maximum zoom in.
- 4 Turn M.FOCUS Ring** until the picture is in focus.
  - It may be necessary to back away from the subject to focus the image properly.
- 5 Press POWER ZOOM to "W" or "T" as desired.**
  - The subject will remain in focus over the entire zooming range.
  - It may be necessary to back away from the subject to focus the image properly.

### Note

- DISPLAY must be set to on for MF, AE, W.BALANCE, or BACK LIGHT to be displayed on the LCD or EVF.

## Macro Focus (for close-ups)

Press the "W" side of POWER ZOOM to the maximum wide angle position. Auto Focus will function with the subject as close as 1 inch (25 mm) in front of the lens.

## Backlight

Use when recording a subject that is darker than the surrounding scene, in a shadowed area, or when the light source is in back of your subject.

BACK LIGHT Button

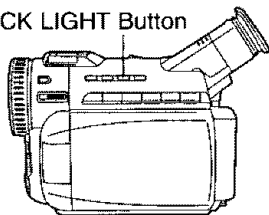

Press **BACK LIGHT** in Record mode to activate the Backlight feature.

The Indicator "⦿" will appear in the EVF or LCD monitor.

Press **BACK LIGHT** again to cancel the Backlight feature.

### Note

- The Indicator "⦿" will not appear in the EVF or LCD monitor when OFF is selected in the DISPLAY menu.

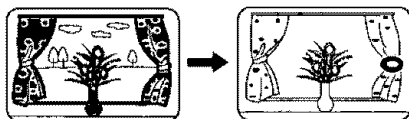

EVF or LCD monitor indication.

## High Speed Shutter

To record high speed motion (e.g. tennis stroke) for improved STILL or SLOW MOTION playback when watching the tape on this Palmcorder.

## Auto Shutter

In the AUTO mode (no indication in the EVF and LCD monitor), the Palmcorder will automatically adjust the shutter speed (up to 1/350).

- AUTO mode is automatically selected whenever the POWER Switch is set to CAMERA.

## Manual Selection

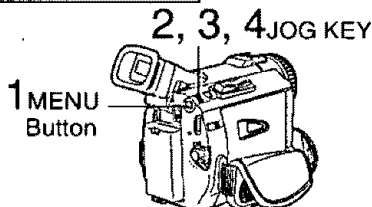

### Note

- For proper color reproduction, it is recommended that you use this feature outdoors. For indoor High Speed Shutter recording, additional halogen or tungsten light should be provided. Fluorescent light will degrade the picture quality.
- This feature requires ample light. More light is required for the fastest shutter speeds.
- The Auto Focus system may not operate properly in insufficient light when using the High Speed Shutter.
- When PROG.AE is ON, you cannot manually select the shutter speed.
- When MAGICVU is ON, Program AE and H.S.S. cannot be set in the menu.

## Audio/Video Fade In/Out

You can make smoother scene transitions for a more professional look.

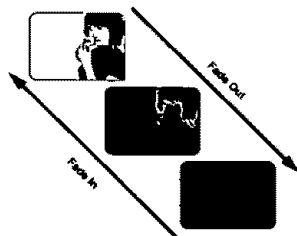
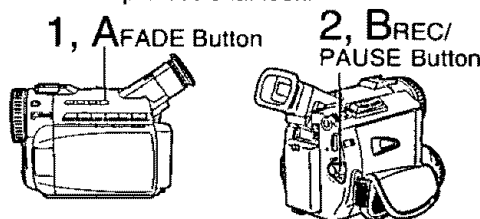

## Before you begin

- Connect the Palmcorder to a power source. (See pages 11, 12.)
- Set POWER Switch to CAMERA.
- Insert a cassette with record tab. (See page 6.)

- 1 Press **MENU** to display the Camera mode menu in the EVF or the LCD monitor.
- 2 Rotate and press **JOG KEY** to select **ADJUST**, then rotate and press **JOG KEY** to select **H.S.S.**.
- 3 Press **JOG KEY** to select **SET**.
  - SHUTTER SPEED menu is displayed.

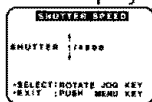

- 4 Rotate **JOG KEY** to choose one of the following shutter speeds.

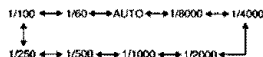

- Press **MENU** three times to exit.

## Fade In

Starting the first scene with "fade in" is very effective.

- 1 In REC/PAUSE mode, hold down **FADE** until the picture fades out.
- 2 Press **REC/PAUSE** to start recording.
- 3 Release **FADE** and the picture will gradually fade in.

## Fade Out

Use to create a soft ending or (together with fade in) for a soft transition from one scene to the next.

- A** During recording, hold down **FADE** until the picture fades out.
- B** Press **REC/PAUSE** to pause the recording.



## Audio Dubbing using the External or Built-in Microphone

The original sound can be replaced with new sound using the built-in Palmcorder microphone or an external microphone.

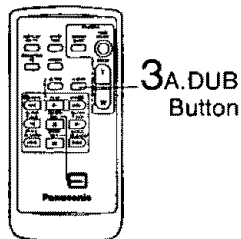
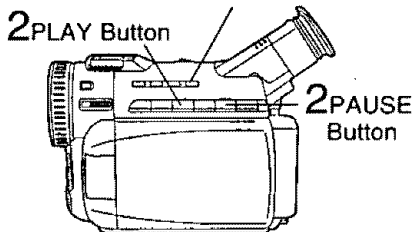
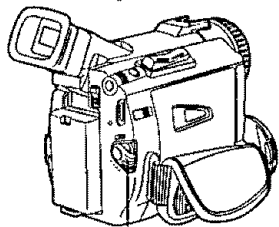
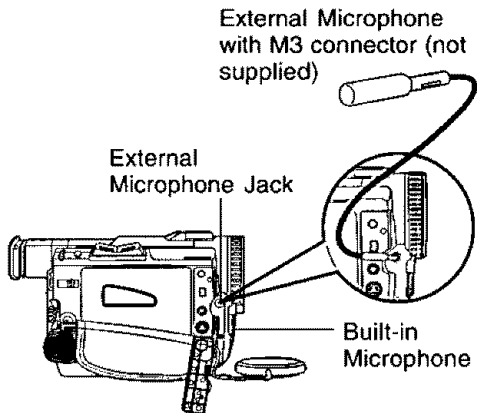

## Before you begin

- Connect the external Microphone (if used).
- Turn on the Palmcorder.
- Insert a pre-recorded tape to be dubbed.

The AUDIO-REC setting in CAMERA MENU mode should be as follows:

12 bit	The original sound is recorded on ST (Stereo) 1, and the new sound will be recorded on ST (Stereo) 2.
16 bit	The original sound is replaced with the new sound.

- Select 12 bit if you do not want the original sound to be completely replaced during an audio dub.
- If you dub over a tape which has both 12 bit and 16 bit audio recordings on it, keep in mind that the original 16 bit audio portion will be completely replaced.

## 1

Set **POWER** to **VCR**.

- The **POWER** lamp lights red.
- Be sure **POWER** is fully turned to **VCR** position.
- With the Remote Control, you can set the Palmcorder to stop automatically at a specified point on the tape. See "Memory-Stop Editing" on page 50.

## 2

Press **PLAY**.

Then press **PAUSE** where you want dubbing to begin.

## 3

Press **A.DUB** on this unit (for 3 seconds) or on the remote control to put the Palmcorder in the Audio Dub mode.

- "A.DUB" flashes in the EVF or the LCD monitor.

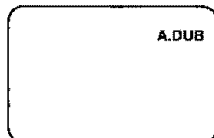

## Note

- The mount at the top of the Palmcorder is only for attaching accessories, such as a microphone. It is not a hot shoe.

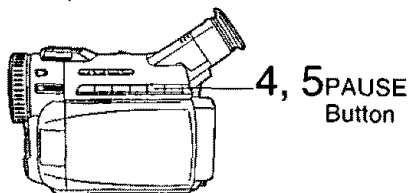

- 4** Press **PAUSE** to start Audio Dubbing.
- Connect the Palmcorder to the TV in order to monitor the sound. (See page 31.)



To listen to the desired audio sound, set the **AUDIO** setting of the VCR mode **MENU** (see page 17) as follows:

**AUDIO:** The following selections are available for 12 bit **AUDIO** dubbed recordings only (sound recorded in **SP** mode only).

<b>ST 1</b>	Set this position to listen to the original sound.
<b>ST 2</b>	Set this position to listen to the audio dubbed sound.
<b>MIX</b>	Set this position to listen to both the original sound and the audio dubbed sound.

**Note**

- 16 bit dubbed sound completely erases the original 16 bit recorded sound.
- If you dubbed using 12 bit **AUDIO** recording and then selected **AUDIO-MIX** in the menu for playback, the sound will be stereo regardless of the **AUDIO-OUT** setting.
- If you recorded in **LP** mode, you cannot use the **A.DUB** feature.

Only **NTSC** (National Television Standards Committee) recorded tapes can be audio dubbed. The following screen appears if the tape was not recorded in **NTSC** format.

- 5** Press **PAUSE** to stop Audio Dubbing.

- If the microphone used for dubbing gets too near the speaker of your TV, a howling noise (feedback) may occur.
- If the tape position is in or was started in a blank section, you cannot use the **A.DUB** feature.

**Memory-Stop Editing (Remote Control Only)**

You can set an automatic Dubbing stop point.

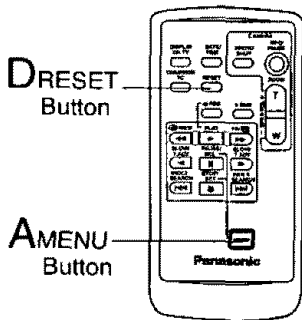

- A** Press **MENU** to display the VCR menu screen.

- B** Rotate **JOG KEY** to select **DISPLAY SETTING**, and then press **JOG KEY** to display the **DISPLAY SETTING** menu.

- C** Rotate **JOG KEY** to select **DISPLAY**, and then press **JOG KEY** to set to **MEMORY**.

- D** Press **MENU** two times to exit **MENU** mode. Then, press **RESET** on the remote control to reset the Counter Memory to **M 0:00:00**.

Now, rewind to the editing start point, and continue with steps 2-5. The tape will now stop automatically at "M 0:00:00".

## Copying your Tapes to S-VHS or VHS Cassette

Source (Playing)  
Palmcorder

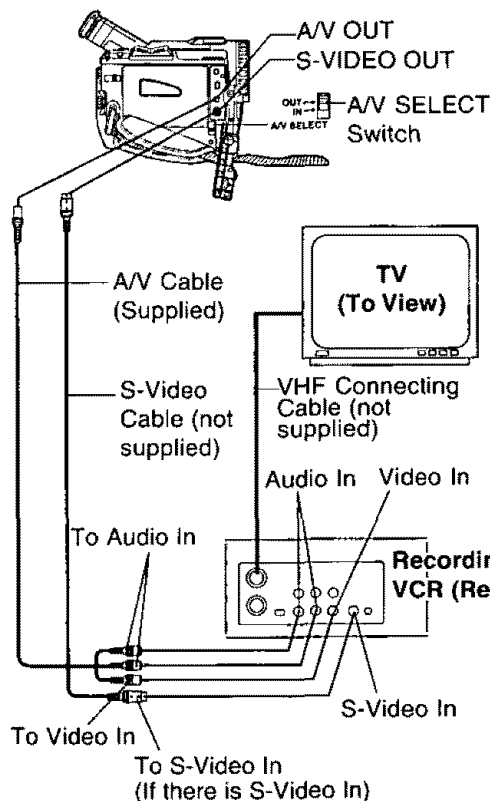

## Before you begin

- Connect both Palmcorder and VCR to their power sources.
- Connect the Palmcorder to a VCR as illustrated left.
- Turn ON both units.
- Set the recording VCR's Input Signal Selector to **LINE**.
- Set the Palmcorder POWER Switch to VCR.

- 1** Insert a pre-recorded tape into the source (playing) Palmcorder and a blank tape, with record tab in place, into the target VCR (Recorder).
- 2** Set **AV SELECT** to **OUT**.
- 3** Press **PLAY** on the Palmcorder. When the tape reaches the point you want to start dubbing, press **PAUSE**.
- 4** Place the VCR into **REC/PAUSE** mode. (See VCR manual.)
- 5** Simultaneously, press **PAUSE** on both units to begin copying.
- 6** Press **STOP** on both units when copying is completed.

## Note

- For technical reasons, dubbing a tape may reduce its quality.
- Press **DISPLAY ON TV** on the Palmcorder remote control to eliminate EVF/LCD Monitor indications.
- If the Time Code is displayed in the EVF or LCD monitor, it cannot be reset.
- Only the **DATE/TIME**, when displayed, will be recorded on the tape.

## Monitor with your TV

- Turn the TV ON and select its VCR channel (either CH3 or CH4).
- Set the VCR/TV Selector on the recording VCR to VCR.

## CAUTION:

Unauthorized exchanging and/or copying of copyrighted recordings may be copyright infringement.

## Copying S-VHS or VHS Cassette to your Tapes

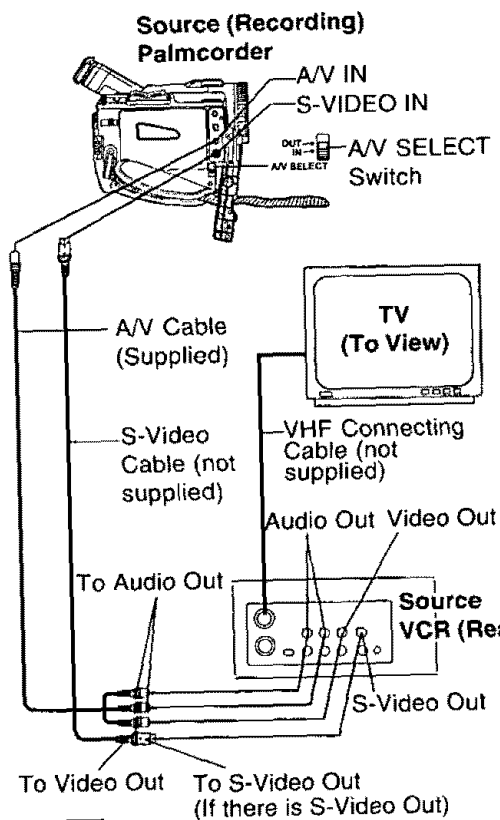

### Note

- OSD functions are not displayed on the TV monitor.
- Do not connect A/V with S-Video on a different unit. The picture and sound may be abnormal.
- If both S-Video Cable and A/V Cable are used, the picture will come from the S-Video Cable.
- Do not connect the A/V Cable and S-Video Cable to other devices.
- If a recording is made at the VCR while the counter is displayed, it cannot be reset.
- Depending on the input signal, the closed caption signal may not be able to be recorded normally.
- Do not change A/V SELECT Switch setting while recording is in progress.

### Before you begin

- Connect both Palmcorder and VCR to their power sources.
- Connect the Palmcorder to a VCR as illustrated left.
- Turn ON both units.

- 1 Insert a pre-recorded tape into the source (playing) VCR and a blank tape with recorded tab closed in place into Palmcorder.
- 2 Set A/V SELECT to IN.
  - "LINE-IN" is displayed on the EVF and LCD monitor. (See page 20.)
- 3 Press PLAY on the VCR. When the tape reaches the point you want to start dubbing, press PAUSE. Hold down REC and press PLAY.
- 4 Press REC and PLAY and then pause the Palmcorder.
- 5 Simultaneously, press PAUSE on both units to begin copying.
- 6 Press STOP on both units when copying is completed.

### CAUTION:

Unauthorized exchanging and/or copying of copyrighted recordings may be copyright infringement.

## Copying from Digital Equipment (dubbing)

High quality digital-to-digital copying can be accomplished if both Palmcorders incorporate the DV Input/Output (i.LINK) Connector (DV interface cable (i.LINK) is not supplied).

### Source (Playing) Palmcorder

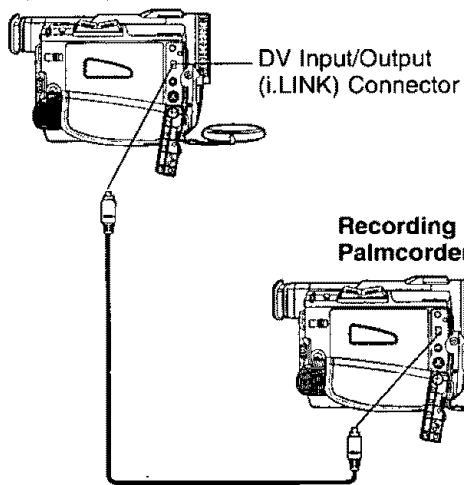

DV Interface Cable (i.LINK) (optional)

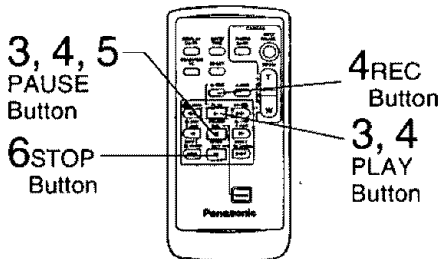
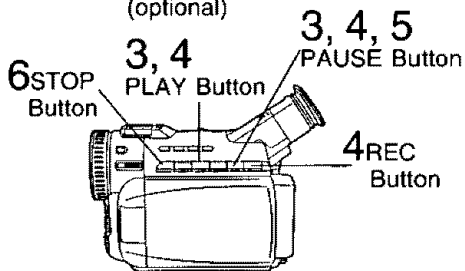

## Before you begin

- Connect both Palmcorders to their power sources.
- Connect the two Palmcorders using the DV interface cable (i.LINK) (4-pin to 4-pin).
- Turn both Palmcorders ON.

- 1** Insert a pre-recorded tape into the source (playing) Palmcorder, and set **POWER** to **VCR**.
- 2** Insert a blank tape with the record tab closed into the target (recording) Palmcorder and set **POWER** to **VCR**.
- 3** Press **PLAY** on the source Palmcorder. When the tape reaches the point you want to start dubbing, press **PAUSE**.
- 4** Hold down **REC** and press **PLAY** on the target (recording) Palmcorder or on the remote control. Press **PAUSE** to pause the tape at the starting point of the dub.
- 5** Simultaneously, press **PAUSE** on both units to begin dubbing.
- 6** Press **STOP** on the recording unit, and then press **STOP** on the playing unit to end dubbing.

### Note

- When two Palmcorders are used for dubbing, it is recommended that the remote control VCR1 or VCR2 setting be used to avoid improper-operation.
- When two Palmcorders are connected using the DV interface cable (i.LINK) (not supplied), a Video Editing Controller cannot be used.
- Do not connect both an S-Video Cable or A/V Cable and a DV Interface Cable (i.LINK).

### CAUTION:

Unauthorized exchanging and/or copying of copyrighted recordings may be copyright infringement.

Special Features

You can transfer images from your Palmcorder tape to your PC (Personal Computer).

### System Requirements:

- IBM PC/AT or compatible
- Intel Pentium II Processor: 266 MHz or more
- Windows 98/Me preinstalled PC with USB port
- RAM: 64 MB or more
- High color (16 bit) or more
- Resolution 800 x 600 (SVGA) or more
- 220 MB minimum available hard disk space (for ArcSoft Software)
- 15 MB minimum available hard disk space (for CARDLINK (for USB) or PHOTOVU LINK/Movie Messenger)
- 120 MB minimum available hard disk space (for USB Motion image capture)
- CD-ROM drive (for installation)
- Mouse or other pointing device

**Palmcorder USB Device Driver** : Software to connect your Palmcorder and your PC using USB Cable.

**PHOTOVU LINK/Movie Messenger** : Software to transfer images from your Palmcorder to your PC.

**CARD LINK (for USB)** : This software to transfer images between the Memory Card and your PC.

**ArcSoft Software\*** : Following software is included: PhotoPrinter 2000 Pro, PhotoImpression 2000, Panorama Maker 2000.

### \* For information on ArcSoft Software:

TEL : 1-510-440-9901  
FAX : 1-510-440-1270  
Web Site : www.arcsoft.com  
E-mail : support@arcsoft.com

### Note

- The Windows 2000 driver is currently not available, but will be available in the future on our website at [www.panasonic.com/video](http://www.panasonic.com/video).

## Software Installation (Windows 98/Me)

### Caution

- Please install Palmcorder USB Device Driver first before connecting the Palmcorder and your PC using USB Cable. Once Palmcorder USB Device Driver is installed, you must restart your computer for installation to take effect.

**1** Turn on the PC (Personal Computer) and start up Windows 98/Me.

**2** Insert the supplied Software CD-ROM into the CD-ROM drive.

**3** Select and click the icon you want to install.

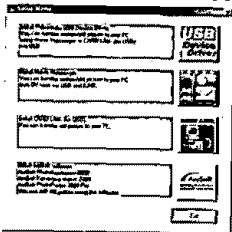

**Palmcorder USB Device Driver** : Click 

**PHOTOVU LINK/Movie Messenger** : Click 

**CARD LINK (for USB)** : Click 

**ArcSoft Software** : Click 

**4** Follow the instructions as they appear on your PC screen.

### Note

- If a window does not appear automatically, click the "Start" button on your desktop and then click "Run". When the Run box is open, type in "D:\InstMenu.exe" where "D:" is the drive letter of your CD; then click "OK".
- If you attempt to install the next Software before the previous Software installation is completed, "Error" may appear. In this case, click [OK] and install the next Software from the menu.

**54**

For assistance, please call : 1-800-211-PANA(7262) or  
send e-mail to : [consumerproducts@panasonic.com](mailto:consumerproducts@panasonic.com)

## Notes on PHOTOVU LINK/Movie Messenger and CARD LINK operation

- For PHOTOVU LINK/Movie Messenger, do not connect the i.LINK and USB terminals to the Palmcorder at the same time.
- Make sure Palmcorder power is not shut off during use, your PC system may become unstable, therefore it is recommended that the AC Adaptor be used as the power source. (Be especially careful when recording in M-CARD or CAMERA mode as the power eventually shuts off automatically if a tape is inserted.)
- For PHOTOVU LINK/Movie Messenger, if the play, stop, fast forward, and rewind functions are operated using the Palmcorder buttons, the image may not be captured properly. Use Palmcorder Operation Buttons displayed on the PC screen.

## Uninstalling Application Software

- 1** Click "Start," "Settings," and "Control Panel."
- 2** Double-click on "Add/Remove Programs" in the "Control Panel."
- 3** Select the application software you want to remove, and then click [Add/Remove].

### Note

- Before uninstalling CARD LINK (for USB), right-click on the CARD LINK (for USB) Monitor, then left-click on "Exit" to close CARD LINK (for USB) Monitor.
- If the "Locked File Detected" dialog box appears while uninstalling the CARD LINK (for USB), close CARD LINK (for USB) Monitor as described above, then click on [Retry].



## Connection

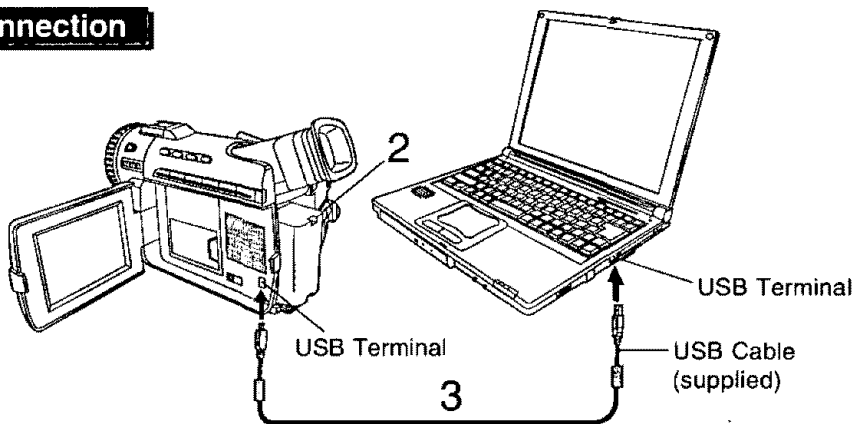

- 1** Turn on your PC.
- 2** Set the Palmcorder POWER to VCR.
- 3** Connect the Palmcorder to your PC (Windows) using the USB Cable (supplied).

### Note

- For extended use, it is recommended to use the AC Adaptor as a power source.

## One Touch Transfer

The images stored on the Memory Card can easily be transferred to the PC by pressing the TRANSFER Button.

### Note

- Before using this feature, make sure the CARD LINK (for USB) monitor icon is displayed.
- Double clicking the CARD LINK Monitor icon displays a dialog box in which the save location for the collective transfer can be changed.

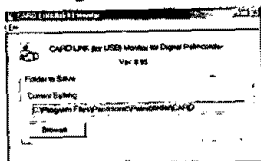

### 3 TRANSFER Button

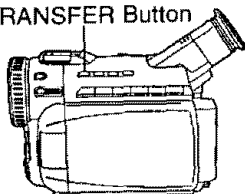

## Running the CARD LINK (for USB)

You can transfer images between the Memory Card and your PC.

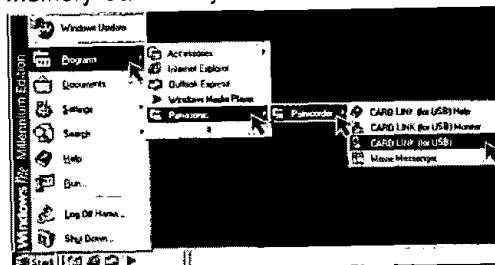

**While CARD LINK is running, do not perform the following operations...**

The PC system may become unstable.

- Change the screen area or color pallet in the Display Properties window.
- Turn the Palmcorder power switch ON or OFF while connecting the Palmcorder to your PC using the USB Cable.
- Connect/disconnect the USB Cable.
- Insert/remove a Memory Card.

## Before you begin

- Set POWER to OFF before inserting a recorded Memory Card. (See pages 32, 33.)
- Turn your PC on.

- 1** Set Palmcorder POWER to CAMERA or slide M-CARD Lock Switch to unlock and set to M-CARD. (See pages 9, 10.)
- 2** Connect the Palmcorder to your PC (Windows) using the USB Cable (supplied). (See page 55.)
  - "CONNECT WITH PC" is displayed on the LCD monitor.
- 3** Click on "Start," "Programs," "Panasonic," "Palmcorder," then "CARD LINK (for USB)."
  - "CARD LINK (for USB)" is opened.
- 4** Press TRANSFER.
  - CARD LINK (for USB) application is run automatically and images stored on the memory card are transferred to your PC and saved. (If an image to be transferred already exists, that image will be skipped over and not transferred.)

### Note

- JPEG image format (only image data that can be played back on Palmcorder) can be transferred from the PC to the Palmcorder.

- 1** Repeat steps 1 and 2 above.
- 2** Click on "Start," "Programs," "Panasonic," "Palmcorder," then "CARD LINK (for USB)."
- 3** "CARD LINK (for USB)" is opened.

### Note

Refer to Help for information about application operations and Error messages.



## Using Memory Card Image Data (CARD LINK (for USB))

Pictures captured with Palmcorder can be transferred to your PC.

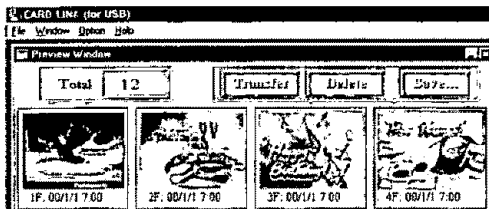

### Note

- If, while transferring the image to your PC, the displayed picture appears abnormal, restart the PC application and turn Palmcorder POWER off, and then back on.

## Using PC Image Data (CARD LINK (for USB))

You can use JPEG or Bitmap files from your computer for Photo Title (see page 38) by transferring them to the Palmcorder via PC connection.

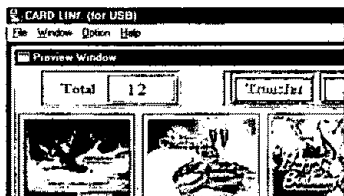

## Before you begin

- Set POWER to OFF before inserting a recorded Memory Card. (See pages 32, 33.)
- Make Palmcorder-PC connections. (See page 55.)
- Turn your PC on. (See page 55.)
- Set Palmcorder POWER to M-CARD. (See page 10.)
- Repeat steps 1 and 2 to run the CARD LINK (for USB). (See "Running the CARD LINK (for USB)" on page 56.)

- 1 Select the image data you want to transfer to your PC.
  - The selected image will be underlined in green.

- 2 Click on:

### Transfer

- The picture image is transferred to your PC and displayed. Transfer Dialog will appear on the PC. The image is captured when the full screen image appears on the PC.

### Delete

- Confirmation Dialog will appear on the PC. Click "OK". The selected images of the Memory Card are deleted.

### Save

- The picture image is transferred to your PC and displayed. [Save as] dialog box will appear.

- 3 Click on the selected image.

- 1 Click on "File," then Click on "Open."

- At your PC, please select and open the data (.jpg or .bmp) you want to transfer to the Palmcorder.

- 2 Click on "File," select "Data out to camera," then select Fine or Normal mode.

- Your computer image data is transferred to the Palmcorder.

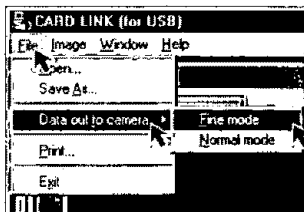

## Running the PHOTOVU LINK/Movie Messenger

You can transfer Motion images and Still images from your Palmcorder tape to a PC.

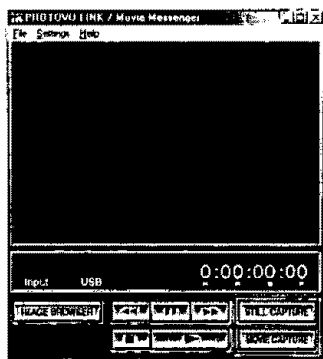
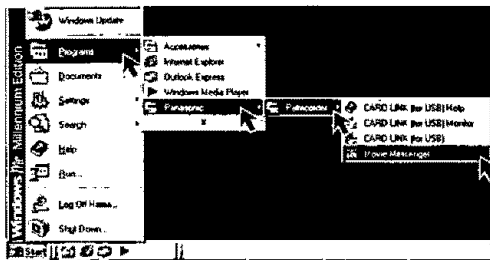

### Before you begin

- Insert a recorded tape. (See page 9.)

- 1 Set Palmcorder POWER to VCR.
- 2 Connect the Palmcorder to your PC using the USB Cable (supplied) or DV interface Cable (i.LINK). (See pages 55, 63.)
- 3 Click on "Start," "Programs," "Panasonic," "Palmcorder," then "Movie Messenger."
- 4 "PHOTOVU LINK/Movie Messenger" is opened.

### Note

Refer to Help for information about application operations and Error messages.

### How to insert the USB Cable or DV Interface Cable (i.LINK)

- A Set Palmcorder POWER to VCR.
- B Connect the Palmcorder to your PC using the USB Cable (supplied) or DV interface Cable (i.LINK).
- C Start up the PHOTOVU LINK/Movie Messenger.

### How to remove the USB Cable or DV Interface Cable (i.LINK)

- A Close the PHOTOVU LINK/Movie Messenger.
- B Remove the USB Cable or DV Interface Cable (i.LINK) from the Palmcorder.
- C Set Palmcorder POWER to OFF.

### While PHOTOVU LINK/Movie Messenger is running, do not perform the following operations...

The PC system may become unstable.

- Change the screen area or color pallet in the Display Properties window.
- Turn the Palmcorder power switch ON or OFF while connecting the Palmcorder to your PC using the USB Cable or DV Interface Cable (i.LINK).
- Change the Palmcorder mode (VCR/CAMERA).
  - \*Close the application before changing the Palmcorder power switch.
- Connect/disconnect the DV Interface Cable (i.LINK).
- Connect/disconnect the USB Cable.

## Using Tape Image Data (PHOTOVU LINK/Movie Messenger) (USB)

By connecting the Palmcorder and PC with the USB Cable, you can transfer Motion images and Still images saved on the DV Tape directly to your PC.

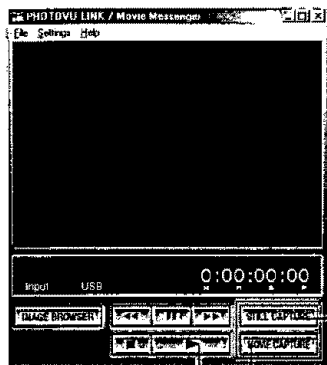

2 PLAY Button

3 STILL  
CAPTURE

3 MOVIE  
CAPTURE



### To capture Still images

- 3 Click on [STILL CAPTURE] at the point you wish to capture an image.
  - Repeat step 3 to continue capturing images.
  - Captured Still images are saved to the PC, and you can playback the saved images on the Image Browser. (See page 60.)

### Before you begin

- Insert a recorded tape. (See page 9.)
- Make Palmcorder-PC connections. (See page 55.)
- Turn your PC on. (See page 55.)
- Set Palmcorder POWER to VCR.

- 1 Repeat steps 1~4 on page 58 to run the PHOTOVU LINK/Movie Messenger.

#### Note

- When the USB Cable is connected, the input display will automatically become USB. If it is not USB, please confirm the connection. Then, close and restart the software.

- 2 Click ► (PLAY) on PC screen to playback the DV tape.

- The playback screen cannot be viewed on the PC. Please use the LCD monitor on the Palmcorder for confirmation.

### To capture Motion images

- 3 Click on [MOVIE CAPTURE] at the start point you wish to capture a Motion image.
- 4 Click [MOVIE CAPTURE] or [STOP] to end capture.
  - "Now Searching" is displayed.
  - The DV Tape is rewound to the point at which the capture was started. The Motion image is then transferred to the PC.
  - "Data transfer is now in progress" is displayed on the PC screen.
  - The maximum capture time is approx. 30 seconds. Capture stops automatically at the end of 30 seconds.

#### Note

- Motion images cannot be captured if data contains the following...
  - A change between 12 bit and 16 bit.
  - A change between SP and LP mode.
- During transfer to the PC, the Motion images will not be displayed on the PC screen.
- Transfer takes from about 30 to 50 seconds for every 1 second of the Motion image when using USB connection.

- 5 To capture other Motion images, repeat steps 3~4.

## Playing back the saved Motion and Still images (PHOTOVU LINK/Movie Messenger)

You can play back the saved Motion images and Still images (see page 59) for confirmation.

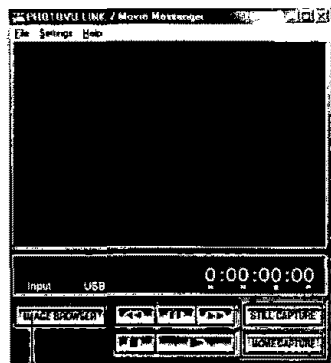

2 IMAGE BROWSER

3 Pictures

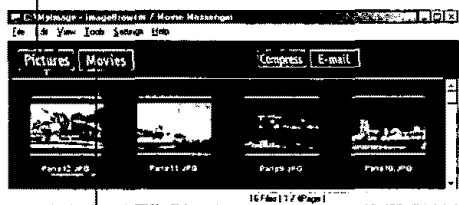

3 Movies

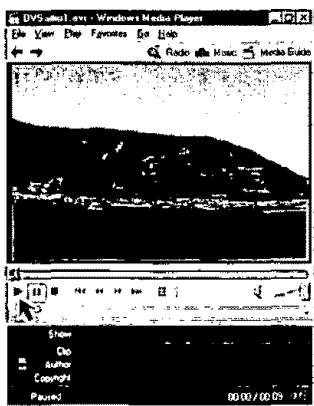

**1** Repeat steps 1~4 on page 58 to run the PHOTOVU LINK/Movie Messenger.

**2** Click [IMAGE BROWSER] to display the Image Browser screen.

### To view Motion images

**3** Click on [Movies].

- The first part of each Motion image will be displayed as a list.

**4** Double click on the desired Motion image to display the playback screen.  
• Click ► to start Motion image playback.

### To view Still images

**3** Click on [Pictures] to display the Still image list.

**4** Double Click on the desired image to open it.

#### Note

- If the image cannot be opened, please refer to the software Help menu.

## To select the e-mail Software (PHOTOVU LINK/Movie Messenger)

You can transfer and compress your Motion images and Still images as attachments to your e-mail easily.

### Note

The e-mail Software must support MAPI (Messaging Application Programming Interface).

Below are some e-mail Software programs which support MAPI:

Microsoft Outlook, Microsoft Outlook Express, Netscape Messenger:

- Outlook(R) Express 5x, Outlook97, Outlook98, Outlook2000
- Outlook Express 4x
- Other MAPI applications [Netscape(R) Messenger 4.5x and so on]

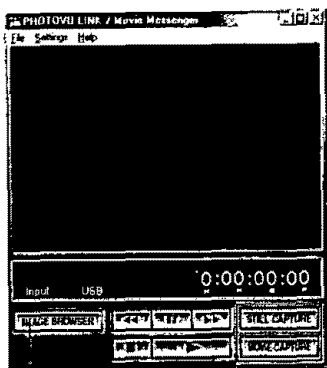

2 IMAGE BROWSER

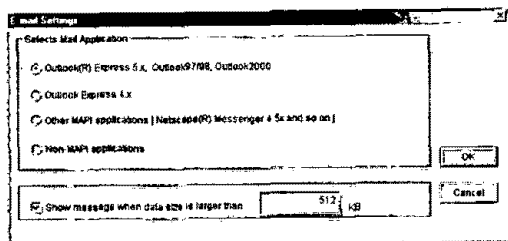

### Before you begin

- Insert a recorded tape. (See page 9.)
- Make Palmcorder-PC connections. (See page 55.)
- Turn your PC on. (See page 55.)
- Set Palmcorder POWER to VCR.

- 1 Repeat steps 1-4 on page 58 to run the PHOTOVU LINK/Movie Messenger. (See Note below.)
- 2 Click [IMAGE BROWSER] to display the Image Browser screen.
- 3 Select "E-mail Settings" from "Settings".
- 4 Select the e-mail software you are using, then click [OK].

### Note

- If the e-mail software does not support MAPI, clicking on [E-mail] of Movie Messenger will not automatically run the e-mail software. Please run the e-mail software before doing step 1 above.

## Attaching captured Motion and Still images to your e-mail

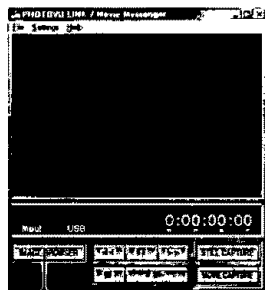

2 IMAGE BROWSER  
4 Compress 4 E-mail

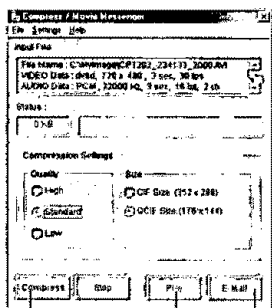
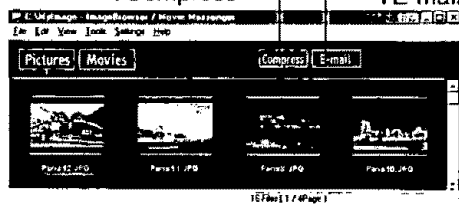

5 Compress 5 Play 6 E-Mail

## Attaching Still images to e-mail

- 3 Click on [Pictures] to display the Still image list.
- 4 Select the image to be attached, then click on [E-mail].
  - The e-mail software will be run automatically and the selected image will be attached to the e-mail. (See Note at right.)

62

For assistance, please call : 1-800-211-PANA(7262) or send e-mail to : consumerproducts@panasonic.com

## Before you begin

- Insert a recorded tape. (See page 9.)
- Make Palmcorder-PC connections. (See page 55.)
- Turn your PC on. (See page 55.)
- Set Palmcorder POWER to VCR.

- 1 Repeat steps 1~4 on page 58 to run the PHOTOVU LINK/Movie Messenger.
- 2 Click [IMAGE BROWSER] to display the Image Browser screen.

## Attaching Motion images to e-mail

- 3 Click on [Movies] to display a Motion image list.
- 4 Select the Motion image to be attached, then click on [Compress].
  - Follow the menu to perform the compression settings.
- 5 Clicking on [Compress] will compress the selected image.
  - "Successfully Done" is displayed on the PC screen.
  - Click [Play] to open the Movie Messenger Player screen. You can confirm the compressed Motion image by clicking on [Play].
- 6 Clicking on [E-Mail] will automatically attach the compressed Motion image to your e-mail. (See Note below.)
  - When the recipient opens the file you sent, this Movie Messenger Player screen appears. By clicking [Play], they can view the Motion Image.

Movie Messenger Player screen

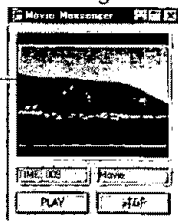

### Note

- Movie Messenger Player works with Windows 95, 98, or Me only.
- If your e-mail software is not supported by MAPI, pressing the [E-Mail] button will automatically open the folder containing the compressed file. To attach, drag and drop the file into your e-mail.

# Transferring Your Images (i.LINK)

## PC Connection with DV Interface Cable (i.LINK)

A live image can be transferred directly to your PC (Personal Computer) via a DV Interface Cable (i.LINK) (not supplied) using products and software from a number of editing software companies including Digital Origin, Canopus, and Pinnacle.

Using Products from these companies allows you to capture and edit live images onto your PC using the DV interface (i.LINK).

For more detailed information regarding editing software products from these companies, please visit their websites at:

[www.digitalorigin.com](http://www.digitalorigin.com)

[www.justedit.com](http://www.justedit.com)

[www.pinnaclesys.com](http://www.pinnaclesys.com)

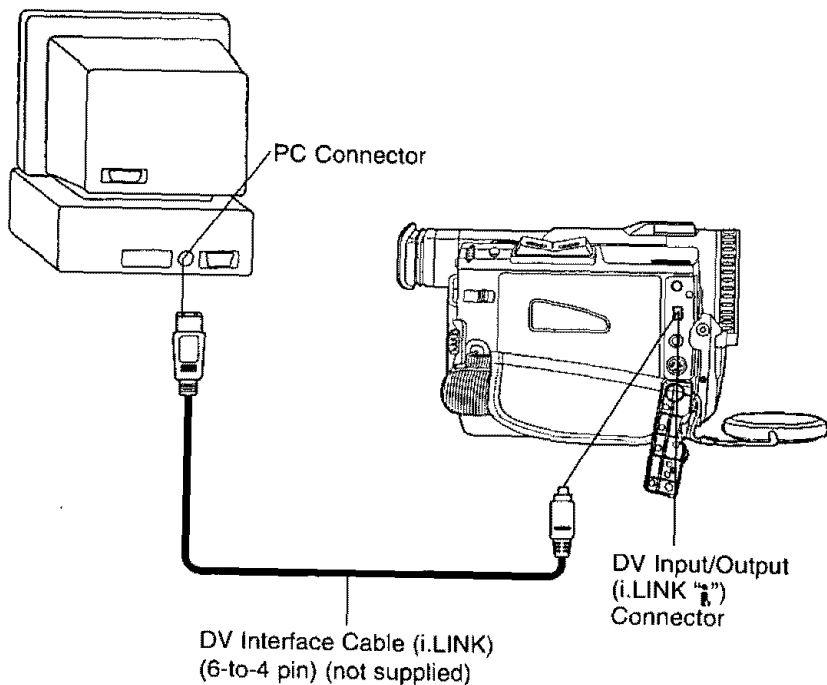

### Note

- PC must be equipped with an i.LINK terminal.
- During Palmcorder playback, do not disconnect the DV Interface Cable (i.LINK) or turn the Palmcorder off as this may cause PC hang-up error to occur.
- For PHOTOVU LINK/Movie Messenger, do not use 2 i.LINK terminals on your PC at the same time.
- PHOTOVU LINK/Movie Messenger i.LINK (DV) operates normally with Windows 98SE or later operating system.
- PHOTOVU LINK/Movie Messenger i.LINK connection may not work with some DV Interface boards. In this case, use the software included with the board.
- 1394 (i.LINK) interface must conform to OHCI (Open Host Controller Interface Specification).

## Using Tape Image Data (PHOTOVU LINK/Movie Messenger)

By connecting the Palmcorder and PC with the DV Interface Cable (i.LINK), you can transfer Motion images and still images saved on the DV Tape directly to your PC.

### Note

- If PHOTOVU LINK/Movie Messenger does not work, please refer to note on page 63.

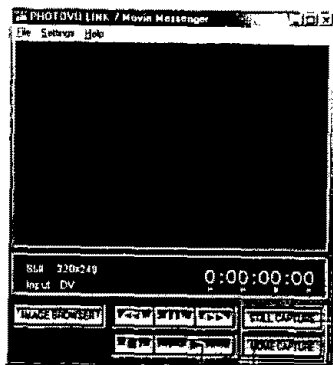

2 PLAY Button

3 MOVIE CAPTURE

3 STILL CAPTURE

## Before you begin

- Insert a recorded Tape. (See page 9.)
- Make Palmcorder-PC connections. (See page 63.)
- Turn your PC on.
- Set Palmcorder POWER to VCR.
- Run the Software after the DV Interface Cable (i.LINK) has been connected to the Palmcorder.

- 1 Repeat steps 1~4 on page 58 to run the PHOTOVU LINK/Movie Messenger.

### Note

- When the DV Interface Cable (i.LINK) is connected, the input display will automatically become DV. If it is not DV, please confirm the connection. Then, close and restart the software.

- 2 Click ► (PLAY) button on PC screen to playback the DV tape.

- Please use the LCD monitor on the Palmcorder or PC screen for confirmation.

## To capture Motion images

- 3 Click on [MOVIE CAPTURE] at the point you wish to capture a Motion image. Click on [STOP] to end capture.









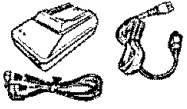

- The image is transferred to the PC in real time.
- The maximum capture time is approx. 3 minutes.
- When capturing data containing changes between 12 bit and 16 bit and/or between SP and LP mode, a separate file will be made for each mode.
- Please refer to pages 60~62 for other functions.

## To capture Still images

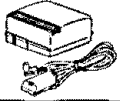
- 3 Click on [STILL CAPTURE] at the point you wish to capture an image.

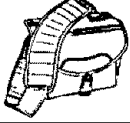
- Repeat step 3 to continue capturing images.
- Captured Still images are saved to the PC, and you can playback the saved images on the Image Browser.

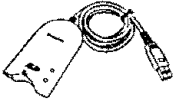

Accessory #	Figure	Description	Price
PV-DAC11		AC Adaptor with AC Cable and DC Cable	\$120.00
CGR-D08A/1B (Replaces CGR-D120A/1B)		800mAh / 1 h 30 min, Battery Pack	\$69.95
CGR-D16A (Replaces CGR-D220A/1B)		1600mAh / 3 h, Battery Pack	\$99.95
CGP-D28A1B		2800mAh/ 5 h, Battery Pack	\$129.95
CGR-D53A/1K (Replaces CGR-D815A/1B)		5300mAh / 9 h, Battery Pack	\$229.95
PV-DDC9		DV Interface Cable (i.LINK) (4-pin to 4-pin)	\$55.00
PV-DRC9		IR Remote Control	\$29.95
PV-H150		Carrying Case	\$49.95
PR-SD064 PR-SD032 PR-SD016		64 MB SD Memory Card 32 MB SD Memory Card 16 MB SD Memory Card	\$179.95 \$119.95 \$79.95
BN-SDCAPU/1B		SD USB Reader/Writer (compatible with MultiMediaCard)	\$79.95
BN-SDABPU/1B		SD PCMCIA Adaptor (compatible with MultiMediaCard)	\$79.95

## Concerning the MultiMediaCard and SD Memory Card

### MultiMediaCard

The MultiMediaCard is a compact, lightweight and removable external memory card. A great many fun-filled titles (preset titles) have been recorded on the supplied MultiMediaCard.

These preset titles will also be erased when the Card is formatted.

### SD Memory Card

The SD Memory Card (optional), which is virtually the same size as the MultiMediaCard, is an external memory card with an even bigger memory capacity. It has a write protect switch to prevent the data writing and card formatting, and it comes with a copyright protection function that complies with the SDMI (Secure Digital Music Initiative) standard. Music play is possible only with an SD Memory Card.

- SD Logo is a trademark.
- Portions of this product are protected under copyright law and are provided under license by ARIS/SOLANA/4C.

# Palmcorder Accessory Order Form

Please photocopy this form when placing an order.

1. Palmcorder Model # \_\_\_\_\_

2. Items Ordered

Accessory #	Description	Price Each	Quantity	Total Price
Subtotal				
Your State & Local Sales Tax				
Shipping & Handling				6.95
Total Enclosed				

3. Method of payment (check one)

- Check of Money Order enclosed (NO C.O.D.SHIPMENTS)
- VISA                      Credit Card # \_\_\_\_\_
- MasterCard              Expiration Date \_\_\_\_\_
- Discover                    Customer Signature \_\_\_\_\_

Make Check or Money Order to: PANASONIC ACCESSORIES

(Please do not send cash)

4. Shipping information (UPS delivery requires complete street address)

Ship To:

Mr. \_\_\_\_\_

Mrs. \_\_\_\_\_

Ms. \_\_\_\_\_

First

Last

Phone #:

Day ( ) \_\_\_\_\_

Street Address

Night ( ) \_\_\_\_\_

City

State

Zip

TO OBTAIN ANY OF OUR PALMCORDER ACCESSORIES YOU CAN DO ANY OF THE FOLLOWING:

VISIT YOUR LOCAL PANASONIC DEALER

OR

CALL PANASONIC'S ACCESSORY ORDER LINE AT 1-800-332-5368

[6 AM-5 PM M-F, 6 AM-10:30 AM SAT, PACIFIC TIME]

OR

MAIL THIS ORDER TO: PANASONIC SERVICES COMPANY ACCESSORY ORDER OFFICE

20421 84th Avenue South Kent, WA. 98032

## Cleaning EVF (Electronic Viewfinder)



**1** Slide the Viewfinder backward to its fully expanded position and then tilt it upward.

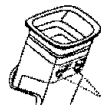

**2** Remove the 2 screws from the EVF Eyepiece with a screwdriver (+).

**3** Turn the Eyepiece counterclockwise 1/8 of a turn.

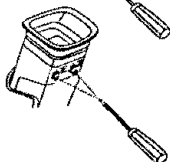

**4** Pull the Eyepiece free.

Remove any lint or dust particles with a soft clean cloth being careful not to scratch the glass surfaces.

**5 To re-install the Eyepiece**

Line up the marks on the Eyepiece with the grooves inside the EVF shaft and attach. Turn it clockwise 1/8 of a turn to lock in place.

**6** Replace the EVF Eyepiece screws and tighten with a screwdriver.

• If you lose an EVF Eyepiece screw, order Part No.XQN2+BJ5FXK.

## Approximate Brightness Values

Your Palmcorder has been designed for normal scene illumination of 150 footcandles (1500 lx). However, the Palmcorder may be used at F1:1.6, if illumination is more than 0.5 footcandles (5 lx).

The table below shows the color temperature for reference.

PALMCORDER SETTINGS	NATURAL LIGHT CONDITIONS	KELVIN COLOR TEMPERATURE	ARTIFICIAL LIGHT SOURCE	COLOR TINT MIXTURE	
<p>(Amber Filter Range)</p> <p>--- "OUTDOOR"</p> <p>"AUTO"</p> <p>--- "INDOOR"</p> <p>(Blue Filter Range)</p>	• Fair weather, blue sky	10,000	• Color television	Bluish	
	• Slightly cloudy sky	8,000	• Fluorescent lamp (Daylight) • Camera flash bulb		
	• Cloudy or rainy sky	7,000			
	• Sunlight in clear weather at midday	6,500			
	• Average sunlight in clear weather	6,000	• Blue lamp for photography	Whitish	
	• Sunlight 2 hours after sunrise and before sunset	5,500			
	• Sunlight 40 min. after sunrise and before sunset	5,000			
	• Sunlight 30 min. after sunrise and before sunset	4,500	• Fluorescent lamp (White) • Normal flash bulb • Fluorescent lamp (Off-white)	Yellowish	
	• Sunlight 20 min. after sunrise and before sunset	4,000			
		3,500			
		• Tungsten lamp for photography	3,200	• Halogen lamp • Iodine lamp	Reddish
		• Tungsten lamp	2,800		
	• Acetylene lamp	2,000			
	• Kerosene lamp		• Candlelight		

<b>Power Source:</b>	Palmcorder: 7.2 V DC (Battery) 7.8 V DC (AC Adaptor) AC Adaptor: 110/120/220/240 V AC, 50/60 Hz Battery: Lithium-Ion Type DC 7.2 V
<b>Power Consumption:</b>	Palmcorder: 7.2 V DC 6.5W (Max. 9.5 W) AC Adaptor :18 W 1 W (when not in use.)
<b>Digital Interface</b>	USB/i.Link (IEEE1394)
<b>Video Signal:</b>	EIA Standard (525 lines, 60 fields) NTSC color signal
<b>Video Recording System:</b>	2 rotary heads, helical scanning system
<b>Audio:</b>	12 bit (32 kHz) 4 tracks 16 bit (48 kHz) 2 tracks
<b>Pick-Up System and Device:</b>	One integral color filter Charge Coupled Device (CCD)
<b>Lens:</b>	20:1 zoom lens, F1:1.6 with auto iris control Focal length: 3.6 mm - 72 mm Power zoom function Lens filter diameter: 43 mm
<b>Viewfinder:</b>	0.44 inch (12.7 mm) Liquid Crystal Electronic Viewfinder
<b>LCD Monitor:</b>	3.0 inch (76.2 mm) Liquid Crystal Display
<b>Minimum Illumination Required:</b>	5 lx (F1:1.6) 0.5 footcandles 0 lx (MAGICVU/OLUX ON)
<b>Memory (Still image)</b>	MultiMediaCard/SD Memory Card 320 x 240 pixels (NORMAL mode) 640 x 480 pixels (FINE mode)
<b>Image Storage (supplied 8 MB Memory Card)</b>	Approx. 240 images (NORMAL mode) Approx. 60 images (FINE mode)
<b>Image Format</b>	JPEG (Design Rule for Camera File System)
<b>Operating Temperature:</b>	32 °F~104 °F (0 °C~40 °C)
<b>Operating Humidity:</b>	10 %~75 %
<b>Weight:</b>	Palmcorder: 1.45 lbs. 0.66 kg AC Adaptor: 0.35 lbs. 0.16 kg
<b>Dimensions:</b>	Palmcorder: 3-3/8 (W) x 4-1/4 (H) x 6-1/2 (D) inch 85 (W) x 107.5 (H) x 166 (D) mm AC Adaptor: 2-3/4 (W) x 1-3/4 (H) x 4-1/2 (D) inch 70 (W) x 45 (H) x 115 (D) mm

Weight and dimensions shown are approximate.  
Designs and specifications are subject to change without notice.

## Cleaning Care for Video Heads

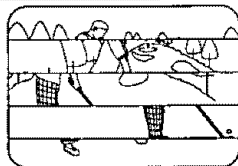

Clogged Video Head

**(a) Video Head Cleaning:** Normally, your Palmcorder will not require head cleaning. However, it is possible that the heads may become clogged due to dust in the air, playing damaged tapes, long term use, etc. If "NEED HEAD CLEANING" appears for 5 seconds in the EVF or LCD monitor, the heads may require cleaning.

**(b) Cleaning the Heads:** It is recommended that head cleaning be performed by a qualified service technician. Please contact your nearest Panasonic Servicenter. An alternate solution is to obtain a head cleaning cassette. Please use Panasonic cleaning cassette (AY-DVMCL). Be sure to follow the cleaning instructions carefully. Excessive use of the head cleaning cassette could shorten video head life.

Use this cassette only when a head clogging symptoms occur.

Refer servicing to qualified service personnel.

## Tape Operations Caution

- When you go from function to function (PLAY, FF, REW etc.), please note that the unit will not accept a new function operation until the previous operation is complete.
- The POWER Button and all function buttons, (PLAY, FF, REW, etc.) are only operational after the tape has been completely loaded.

## Lens Hood Area Operation Caution

When the following accessories are attached and the zoom is set to maximum wide angle, the four corners of the scene may appear darker:

- Wide or Telephoto conversion lens (optional).
- A filter (optional), etc. and then the lens hood.
- Two filters (optional).

## Self Diagnostic System

If any of the following numbers appear on-screen, the camcorder may need service. Do not remove the battery (if attached) and write down the displayed number on page 71.

Then, take the camcorder to a servicenter for repair.

Error No.	Description
U11	Card Error
U12	Card Error
U13	Card Error
U14	Card/Camcorder Dialogue Error
U15	No Card Memory
U16	Captured image limit exceeded
U17	Captured image limit exceeded
U30	Error other than above

# Before Requesting Service

If you have a problem with your Palmcorder, it may be something you can correct yourself. Check the list below for symptoms and corrections.

Symptom	Correction
No picture in the EVF or LCD Monitor...	<ul style="list-style-type: none"><li>• Make sure the Power Source is connected. (pp. 11, 12)</li><li>• Make sure the POWER switch is set to VCR or CAMERA. (pp. 22, 27)</li><li>• Check the Dew Indicator. (p. 21)</li><li>• Make sure the Battery is fully charged. (p. 11)</li><li>• Make sure all necessary cables are connected correctly and firmly. (p. 12)</li><li>• Make sure the Lens Cap is removed. (p. 22)</li></ul>
Video cassette cannot be inserted...	<ul style="list-style-type: none"><li>• Make sure the Power Source is connected. (pp. 11, 12)</li><li>• Insert the cassette record tab up, window side facing out. (p. 9)</li></ul>
Video cassette cannot be removed...	<ul style="list-style-type: none"><li>• Make sure the Power source is connected. (pp. 11, 12)</li></ul>
No operation starts when operation buttons are pressed...	<ul style="list-style-type: none"><li>• Check the Dew Indicator. (p. 21)</li></ul>
Recording cannot be done...	<ul style="list-style-type: none"><li>• Make sure the record tab is closed. (p. 6)</li><li>• Check the Battery Indication. (p. 19)</li></ul>
Auto Focus does not operate...	<ul style="list-style-type: none"><li>• Make sure FOCUS is set to AUTO. (p. 47)</li><li>• Make sure the unit is ON and set to CAMERA mode. (p. 22)</li></ul>
Sound from microphone cannot be monitored...	<ul style="list-style-type: none"><li>• Make sure the unit is set to REC or REC/PAUSE mode.</li></ul>
Sound cannot be heard...	<ul style="list-style-type: none"><li>• Make sure the Audio on the VCR MENU is set to ST1. (pp. 17, 49)</li></ul>

## Request for Service Notice

Please photocopy this form when making a request for service notice.

### Request for Service Notice:

In the unlikely event this product needs service.

- Please include your **proof of purchase**. (Failure to do so will delay your repair.)
- To further speed your repair, please provide an explanation of what is wrong with the unit and any symptom it is exhibiting.

Mail this completed form and your Proof of Purchase along with your unit to:

Panasonic Services Company  
1705 N. Randall Road  
Elgin, IL. 60123-7847  
Attn: Camcorder Repair

Please write the displayed Self Diagnostic number here. (See page 70.)

## Front View

### D.ZOOM Button

See page 40.

### EIS Button

See page 39.

### TRANSFER Button

See page 56.

### M.FOCUS Button

See page 47.

### MAGICVU/OLUX Switch

See page 42.

### Lens

### Lens Cap

See page 8.

### BACK LIGHT Button

See page 47.

### FADE Button

See page 48.

### A.DUB Button

See page 49.

### Remote Sensor

See page 25.

### Built-in Twin Capsule 2-Way Microphone System

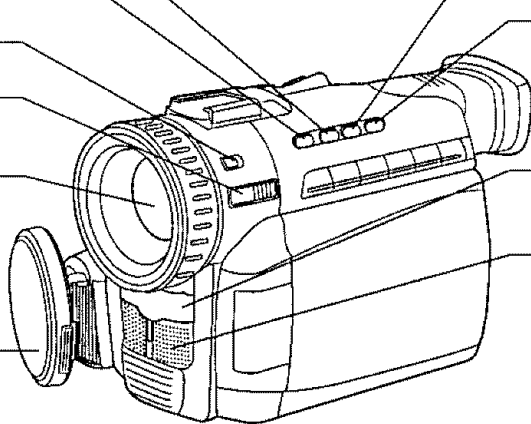

## Side View

### PHOTOSHOT Button

See pages 32, 33, 41.

### Cassette Compartment Cover

See page 7.

### TAPE EJECT Switch

See pages 7, 9.

### Hand Strap

See page 8.

### Accessory Mount

See page 49.

### PHONE Jack

See page 27.

### DV Input/Output (i.LINK "i") Connector

See pages 53, 63.

### External Microphone Jack

See page 49.

### A/V Input/Output Connector

See pages 31, 51, 52.

### S-VIDEO Input/ Output Connector

See pages 31, 51, 52.

### A/V SELECT Switch

See pages 31, 51, 52.

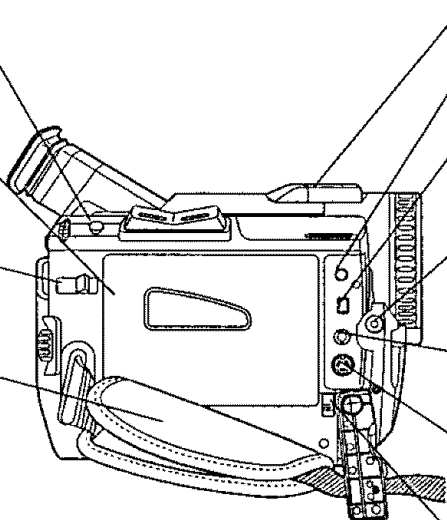



## Rear View

**Electronic Viewfinder (EVF)**  
See page 9.

**Vision Adjustment Control**  
See pages 9, 22.

**Menu Button**  
See pages 13, 14.

**Battery Release Button**  
See pages 11, 22.

**POWER Lamp**  
See page 22.

**REC/PAUSE Button**  
See pages 9, 22.

**Shoulder Strap Attachment Ring**  
See page 8.

**JOG KEY**  
See pages 13, 14.

**VOLUME KEY**  
See page 27.

**POWER ZOOM Button**  
See pages 22, 40.

**M.FOCUS Ring**  
See page 47.

**Shoulder Strap Attachment Ring**  
See page 8.

**M-CARD Lock Switch**  
See page 10.

**POWER Switch (CAMERA•VCR•OFF•M-CARD)**  
See pages 9, 10.

## Rear View

**LCD (Liquid Crystal Display) Monitor**  
See pages 9, 10, 23, 27.

**M-CARD Door**  
See page 10.

**Built-in Speaker**  
See page 27.

**DC IN Terminal**  
See page 12.

**USB Terminal**  
See page 55.

**LCD-OPEN Button**  
See pages 9, 10, 23, 27.

**CARD EJECT Switch**  
See page 10.

## Side View

### REW Button

See pages 10, 27.

### EDIT SEARCH Button

See pages 24.

### STOP Button

See pages 10, 27.

### M-STOP Button

See pages 34, 35, 36, 37.

### Built-in Light

See page 7.

### PLAY Button

See pages 10, 27.

### M-PLAY Button

See pages 34, 35.

### FF Button

See page 28.



### SEARCH Button

See page 24.

### PAUSE Button

See pages 28, 29, 49, 50, 51, 52.

### CAMERA STILL Button

See pages 45.

### REC Button

See page 52.

### M-DEL Button

See pages 35, 36, 37.

## Underside View

### Tripod

Receptacle

## AC Adaptor

### POWER Lamp

See pages 11, 12.

### AC Power Cord

See pages 11, 12.

### CHARGE Lamp

See page 11.

### VCR DC Output Connector

See page 12.

## CAUTION:

This unit will operate on 110/120/220/240 V AC. An AC plug adaptor may be required for voltages other than 120V AC. Please contact either a local or foreign electrical parts distributor for assistance in selecting an alternate AC plug.

We recommend using the accessory power plug adaptor (VJSS0070) in an area which has special AC outlets.

# Remote Control

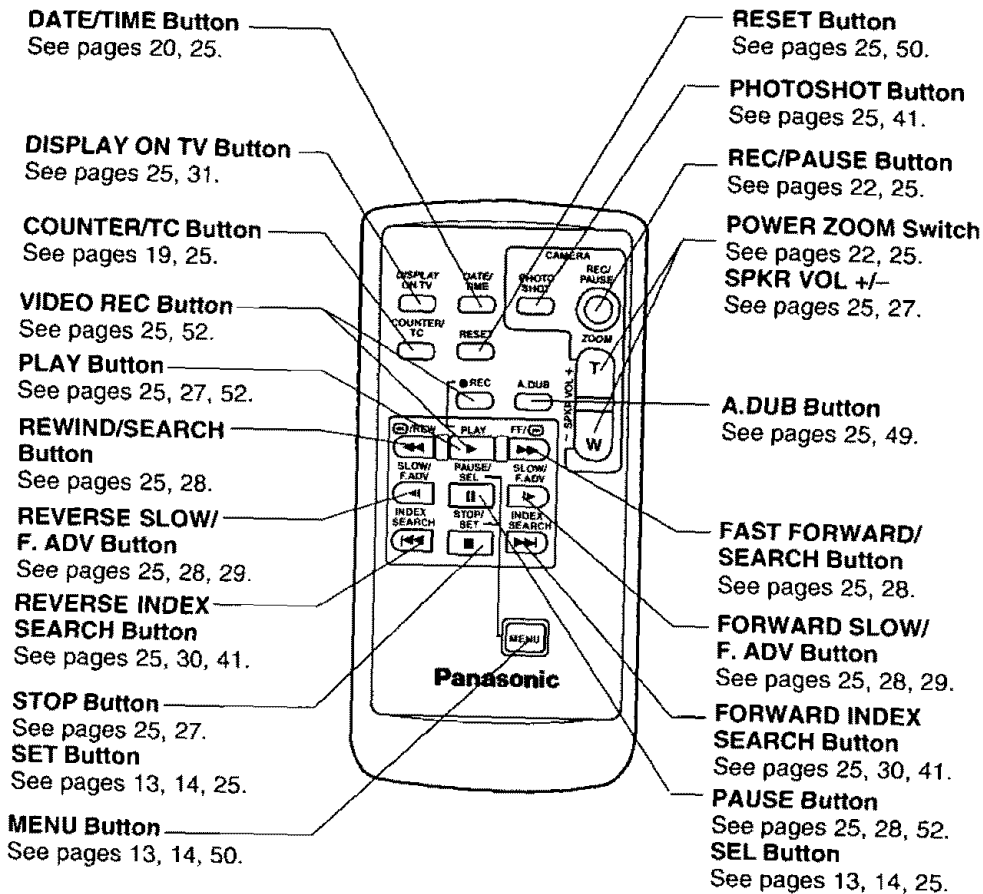

Panasonic Consumer Electronics Company,  
Division of Matsushita Electric Corporation  
of America, One Panasonic Way  
Secaucus, New Jersey 07094

Panasonic Sales Company,  
Division of Matsushita Electric of Puerto Rico, Inc.  
AVE. 65 de Infantería, Km. 9.5 San Gabriel  
Industrial Park Carolina, Puerto Rico 00985

## PANASONIC Video Products Limited Warranty

Panasonic Consumer Electronics Company or Panasonic Sales Company (collectively referred to as "the Warrantor") will repair this product with new or refurbished parts, free of charge, in the USA or Puerto Rico, in the event of a defect in materials or workmanship as follows (all time periods commence from the date of the original purchase):

PRODUCT	PARTS	LABOR	SERVICE	CONTACT NUMBER
CAMCORDER	ONE (1) YEAR, EXCEPT CCD IMAGE SENSOR CCD IMAGE SENSOR -SIX (6) MONTHS	NINETY (90) DAYS  NINETY (90) DAYS	Carry-in or Mail In	1-800-211-PANA(7262)
VCR	ONE (1) YEAR	NINETY (90) DAYS	Carry-in or Mail In	1-800-211-PANA(7262)
A/V MIXER	ONE (1) YEAR	NINETY (90) DAYS	Carry-in or Mail In	1-800-211-PANA(7262)
MONITOR- VCR Combination	ONE (1) YEAR, EXCEPT CRT CRT - TWO (2) YEARS	NINETY (90) DAYS CRT - NINETY (90) DAYS	Carry-in: 21" CRT and Smaller  In-home or carry-in: 22" CRT and Larger	1-800-211-PANA(7262)

**Batteries** (if included) - New rechargeable batteries in exchange for defective rechargeable batteries for ten (10) days. Non-rechargeable batteries are not warranted.

**Tape** (if included) - New video cassette tape in exchange for a defective video cassette tape for five (5) days.

In-home, carry-in or mail-in service, as applicable, in the USA can be obtained during the warranty period by contacting a Panasonic Services Company (PASC) Factory Servicenter listed in the Service Directory. Or call toll free contact number listed above, to locate an authorized PASC Servicenter. Carry-in or mail-in service in Puerto Rico can be obtained during the warranty period by calling the Panasonic Sales Company telephone number listed in the Servicenter Directory.

This warranty is extended only to the original purchaser. A purchase receipt or other proof of the date of the original purchase is required before warranty service is rendered.

This warranty only covers failures due to defects in materials and workmanship which occur during normal use and does not cover normal maintenance, including, but not limited to, video and audio head cleaning. The warranty does not cover damage which occurs in shipment, or failures which are caused by products not supplied by the warrantor, or failures which result from accident, misuse, abuse, neglect, mishandling, misapplication, alteration, modification, faulty installation, set-up adjustments, improper antenna, inadequate signal pickup, maladjustment of consumer controls, improper operation, power line surge, improper voltage supply, lightning damage, commercial use such as hotel, office, restaurant, or other business or rental use of the product, or service by anyone other than a PASC Factory Servicenter or a PASC authorized Servicenter, or damage that is attributable to acts of God.

### LIMITS AND EXCLUSIONS

There are no express warranties except as listed above.

THE WARRANTOR SHALL NOT BE LIABLE FOR INCIDENTAL OR CONSEQUENTIAL DAMAGES (INCLUDING, WITHOUT LIMITATION, DAMAGE TO RECORDING MEDIA) RESULTING FROM THE USE OF THIS PRODUCTS, OR ARISING OUT OF ANY BREACH OF THE WARRANTY. ALL EXPRESS AND IMPLIED

WARRANTIES, INCLUDING THE WARRANTIES OF MERCHANTABILITY AND FITNESS FOR PARTICULAR PURPOSE, ARE LIMITED TO THE APPLICABLE WARRANTY PERIOD SET FORTH ABOVE.

Some states do not allow the exclusion or limitation of incidental or consequential damages, or limitations on how long an implied warranty lasts, so the above exclusions or limitations may not apply to you.

This warranty gives you specific legal rights and you may also have other rights which vary from state to state.

If a problem with this product develops during or after the warranty period, you may contact your dealer or Servicenter. If the problem is not handled to your satisfaction, then write to the Consumer Affairs Department at the Panasonic Consumer Electronics Company address above.

SERVICE CALLS WHICH DO NOT INVOLVE DEFECTIVE MATERIALS OR WORKMANSHIP AS DETERMINED BY THE WARRANTOR, IN ITS SOLE DISCRETION, ARE NOT COVERED. COSTS OF SUCH SERVICE CALLS ARE THE RESPONSIBILITY OF THE PURCHASER.

warvid 8/8/2000

For Product Information, Operating Assistance, Literature Request, Dealer Locations, and all Customer Service inquiries please contact:  
**1-800-211-PANA(7262)**, Monday-Friday 9am-9pm Saturday-Sunday 9am-7am, EST.  
 or send e-mail : [consumerproducts@panasonic.com](mailto:consumerproducts@panasonic.com)

**Web Site: <http://www.panasonic.com>**  
 You can purchase parts, accessories or locate your nearest servicenter by visiting our Web Site.

**Accessory Purchases:**

1-800-332-5368 (Customer Orders Only)  
**Panasonic Services Company 20421 84th Avenue South, Kent, WA 98032**  
 (6 am to 5 pm Monday - Friday; 6 am to 10:30 am Saturday; PST)  
 (Visa, Master Card, Discover Card, American Express, Check)

**Product Repairs**

**Centralized Factory Servicenter**

**MAIL TO :**  
 Panasonic Services Company  
 1705 N. Randall Road,  
 Elgin, IL 60123-7847  
 Attention: Digital Camera Repair

Please carefully pack and ship, prepaid and insured, to the Elgin centralized repair Factory Servicenter. While there will be added handling delays, you may bring your unit to one of the following locations who will then forward the unit to Elgin for repair.  
 Customer's in Puerto Rico, please ship or carry in to location below ("Service in Puerto Rico").

**Factory Service Center Locations**

**CALIFORNIA**

6550 Katella Avenue  
 Cypress, CA 90630  
 800 Dubuque Avenue  
 S. San Francisco,  
 CA 94080  
 3878 Ruffin Road  
 Suite A  
 San Diego, CA 92123

**COLORADO**

1640 South Abilene  
 Street Suite D  
 Aurora, CO 80012

**FLORIDA**

3700 North 29th Avenue  
 Suite 102  
 Hollywood, FL 33020

**GEORGIA**

8655 Roswell Road  
 Suite 100  
 Atlanta, GA 30350

**ILLINOIS**

9060 Golf Road  
 Niles, IL 60714  
 1703 North Randall Road  
 Elgin, IL 60123  
 (Pick-up / Drop-off only)

**MARYLAND**

62 Mountain Road  
 Glen Burnie MD 21061

**MASSACHUSETTS**

60 Glacier Drive,  
 Suite G  
 Westwood, MA 02090

**MINNESOTA**

7850-12th Avenue South  
 Airport Business Center  
 Bloomington, MN 55425

**OHIO**

2236 Waycross Road  
 Civic Center Plaza  
 Forest Park, OH 45240

**PENNSYLVANIA**

2221 Cabot Blvd. West  
 Suite B  
 Langhorne, PA 19047

**TEXAS**

13615 Welch Road  
 Suite 101  
 Farmers Branch,  
 TX 75244

**WASHINGTON**

20425-84th Avenue  
 South  
 Kent, WA 98032

**HAWAII**

99-859 Iwaiwa Street  
 Aiea, Hawaii 96701  
 Phone (808) 488-1998  
 Fax (808) 486-4369

**Service in Puerto Rico**

**Matsushita Electric of Puerto Rico, Inc. Panasonic Sales Company/ Factory Servicenter:**  
 Ave. 65 de Infanteria. Km. 9.5 San Gabriel Industrial Park Carolina, Puerto Rico 00985  
 Phone (787) 750-4300 Fax (787) 768-2910

Information List

## Inserte de la batería

## Antes de comenzar

- Cargue la batería. (Página 11.)

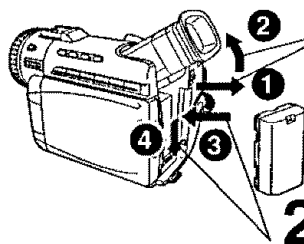

**1** Deslice el visor hacia atrás, hasta la posición de totalmente extendido, y luego inclínelo hacia arriba.

**2** Coloque la batería y deslicela hacia abajo hasata que quede bloqueada con un clic.

## Inserte el Cassette

**1** Ajuste el interruptor de alimentación (POWER) a la posición VCR o CAMERA.

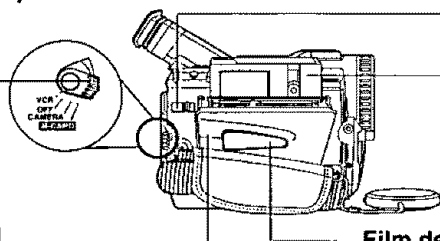

**2** Deslice el interruptor de expulsión de cinta (TAPE EJECT) para abrir la tapa del compartimento del cassette.

**3** Introduzca un cassette con la parte de la ventana hacia arriba.  
• Asegúrese de que la lengüeta de grabación esté cerrada. (Página 6.)

**4** Presione la marca PUSH TO CLOSE (EMPUJAR PARA CERRAR) para cerrar la tapa del compartimento del cassette.

Film de protección

### Nota

- Retire la película protectora antes de utilizarlo.

## Grabación con la cámara

Cuando el monitor LCD se encuentra totalmente abierto, el visor se DESACTIVA automáticamente.

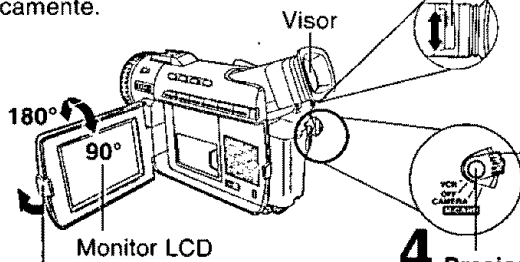

**2** Ajuste el control de ajuste de visión según lo desee.

**1** Ajuste el interruptor de alimentación (POWER) a la posición CAMERA.

**3** Presione el botón de apertura del LCD (LCD-OPEN) para desbloquear el monitor LCD. Balancee abriéndolo completamente y ajuste el ángulo.

**4** Presione el botón de grabación/pausa (REC/PAUSE) para iniciar la grabación. Vuelva a pulsar el botón de grabación/pausa (REC/PAUSE) para hacer una pausa en la grabación.

## Introducir la Tarjeta de memoria\*

### Antes de comenzar

- Cargue la batería. (Página 11.)

\*Tarjeta de Memoria: Tarjeta MultiMedia o Tarjeta de Memoria SD (Página 65.)

- Asegúrese de introducir la Tarjeta de memoria antes de utilizar la tarjeta PhotoShot. (Página 32.)

A continuación se indican una lista de Tarjetas de Memoria soportadas por esta unidad.

Tarjeta de memoria	Capacidad
Tarjeta MultiMedia (LSFT0198A) (suministrado)	8 MB
Tarjeta MultiMedia (Marca de fábrica SanDisk)	8 MB, 16 MB
Tarjeta de Memoria SD (opcional) (Página 65.)	16 MB, 32 MB, 64 MB

Monitor LCD

Puerta de M-CARD

Botón para interrumpir el cambio al M-CARD

1 Ajuste el interruptor de alimentación (POWER) a la posición OFF.

2 Presione el botón de apertura del LCD (LCD-OPEN) para desbloquear el monitor LCD. **Balancée** abriéndolo completamente y ajuste el ángulo.

3 Deslice el CARD EJECT Switch (interruptor de EJECUCIÓN DE TARJETA) para abrir la puerta de M-CARD.

4 Introducir la Tarjeta de memoria.

5 Cierre la puerta de M-CARD.

## Para ver la reproducción en el LCD (pantalla de visualización de cristal líquido)

Cuando el monitor LCD se encuentra totalmente abierto, el visor se DESACTIVA automáticamente.

### Antes de comenzar

- Cargue la batería. (Página 11.)

180°

90°

1 Ajuste el interruptor de alimentación (POWER) a la posición VCR.

2 Presione el botón de apertura del LCD (LCD-OPEN) para desbloquear el monitor LCD. **Balancée** abriéndolo completamente y ajuste el ángulo.

3 Presione el botón de rebobinado (REW) para rebobinar la cinta.

4 Presione el botón de reproducción (PLAY) para reproducir la cinta.

5 Presione el botón de parada (STOP) para detener la reproducción.

<b>A</b>					
AC Adaptor	6, 11, 12, 65	Macro Focus		47	
Accessories (Optional)	65	MAGICVU/OLUX		42	
Accessories (Supplied)	6	Manual Focus		47	
A/V Cable	6, 31, 51, 52	Memory Counter		19	
A/V SELECT Switch	51, 52	MENU OSD	14, 15, 16, 17, 18		
Audio/Video Fade In/Out	48	MultiMediaCard		6, 10	
Auto Focus	47	M-CARD Door		10	
<b>B</b>		<b>P</b>			
Backlight	47	PC Connection	55, 63		
Battery Pack	6, 9, 11, 65	Picture in Picture (PinP)	45		
Battery Remaining Indication	19	PLAY Indicator	20		
Battery Warning	21	Playback	27, 28, 29, 30, 31		
Before Requesting Service	70, 71	Power Supply	11, 12		
Blank Search	25	Program AE	43		
Built-in Light	7	<b>R</b>			
<b>C</b>		REC Indicator	20		
CARD EJECT Switch	10	Recording Still Pictures	42		
Camera Recording	22, 23, 24, 25	Remote Control	25, 26, 65, 75		
Cleaning Care for Video Heads	70	Request for Service Notice	71		
Clock Battery	21	<b>S</b>			
Clock Set	13	Safety Precautions	2		
Copying from Digital Equipment	53	Servicenter	77		
Copying your Tapes	51, 52	Set the Date and Time	13		
<b>D</b>		Shoulder Strap	6, 8		
Date and Time Indication	20	Special Effects Playback	28, 29, 30		
DC Power Cable	6, 12, 65	Specifications	69		
DEW Indication	21	STILL Picture	28		
Digital E.I.S.	39	Strobe Multi Mode	46		
Digital Functions	44	<b>T</b>			
Digital Photo Shot	41	Tape Remaining Indications	19		
Digital Video Cassette Tape	6	Tape Speed	6		
Digital Zoom	40	Tape Warning	21		
Dubbing over Audio (Microphone)	49, 50	<b>U</b>			
DV Interface Cable (i.LINK)	53, 54, 65	USB Cable	6, 56		
<b>E</b>		<b>V</b>			
Edit Search	24	VHF Connecting Cable	51		
Erase Protection Tab	6	Volume Display	27		
EVF/LCD Monitor Indications	19, 20, 21	<b>W</b>			
<b>H</b>		White Balance	42		
Hand Strap	8	<b>Z</b>			
High Speed Shutter	48	Zoom In/Out	40		
<b>J</b>					
Jog Search	29				
<b>L</b>					
Lens Cap	6, 8, 22				
Limited Warranty	76				

**Panasonic Consumer Electronics Company, Division of Matsushita Electric Corporation of America**  
 One Panasonic Way Secaucus,  
 New Jersey 07094

**Panasonic Sales Company ("PSC"),  
 Division of Matsushita Electric of  
 Puerto Rico, Inc.**  
 Ave. 65 de Infanteria, Km. 9.5  
 San Gabriel Industrial Park  
 Carolina, Puerto Rico 00985



Printed in Japan  
 LSQT0365A  
 S0101A0