

# Installation & Operation Instructions

## **ARCTIC AIR**

### An Important Message for Installers and Operators

These instructions include information which is intended to assure the operator of correct installation, operation and service. Before attempting installation, adjustment or maintenance, be certain of the following:

1. That you have read and fully understand the instructions.
2. That you have all tools required and are trained to use them.
3. That you have met all installation and usage restrictions and are familiar with the functions and operation of the unit.
4. That you follow all instructions exactly as given.

All fittings, measurements, procedures and recommendations are significant. Substitutions and approximations must be avoided. Improper handling, maintenance, installation and adjustment, or service attempted by anyone other than a qualified technician, may void the future warranty claims and cause damage to the unit and/or result in injury to the operator and/or bystanders.

### **IMPORTANT**

Important information is contained in these instructions which should be retained in a convenient location for future reference.

### Record of Service

Model No. \_\_\_\_\_

Serial No. \_\_\_\_\_

Installation Date \_\_\_\_\_

Invoice Date \_\_\_\_\_

Start-up Date \_\_\_\_\_

Telephone for Service \_\_\_\_\_

**BE SURE TO INSPECT THE CABINET FOR SHIPPING DAMAGE  
BEFORE AND AFTER UNCRATING IT.**



**BROICH ENTERPRISES, INC**  
6440 City West Parkway.  
Eden Prairie, MN 55344  
Phone: 952-941-2270  
Fax: 952-941-3066

## Proper Disposal of Your Refrigerator/Freezer

**⚠ WARNING** Risk of child entrapment. Child entrapment and suffocation are not problems of the past. Junked or abandoned refrigerators or freezers are still dangerous — even if they will sit for "just a few days." If you are getting rid of your old refrigerator or freezer, please follow the instructions below to help prevent accidents.

### BEFORE YOU THROW AWAY YOUR OLD REFRIGERATOR/FREEZER:

- Remove doors.
- Leave shelves in place so children may not easily climb inside.

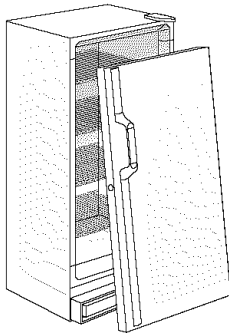

**⚠ WARNING** Avoid fire hazard or electric shock. Do not use an extension cord or an adapter plug. Do not remove any prong from the power cord.

### Grounding type wall receptate

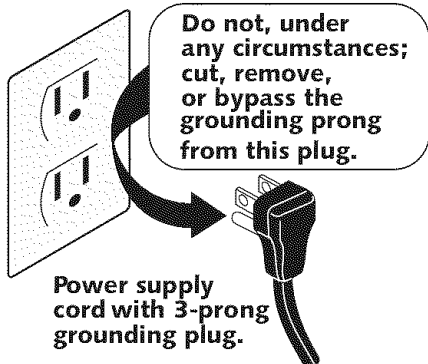

## Read All Instructions Before Using This Freezer.

### ⚠ WARNING FOR YOUR SAFETY

Do not store or use gasoline, or other flammable vapors and liquids in the vicinity of this or any other appliance. Read product labels for flammability and other warnings.

### ⚠ WARNING Child Safety

- Destroy carton, plastic bags, and any exterior wrapping material immediately after the freezer is unpacked. Children should never use these items to play. Cartons covered with rugs, bedspreads, plastic sheets or stretch wrap may become airtight chambers, and can quickly cause suffocation.
- **A child might suffocate if he crawls into a freezer to hide or play. Remove the door of a freezer when not in use, even if you plan to discard the freezer.** Many communities have laws requiring you to take this safety precaution.

### ⚠ WARNING Electrical Information

**These guidelines must be followed to ensure that safety mechanisms in the design of this freezer will operate properly.**

- **Refer to the serial plate for correct electrical rating.** The power cord of the appliance is equipped with a three-prong grounding plug for your protection against shock hazards. It must be plugged directly into a properly grounded three-prong receptacle, protected with a 15 amp time delay fuse or circuit breaker. The receptacle must be installed in accordance with local codes and ordinances. Consult a qualified electrician. Receptacles protected by Ground Fault Circuit Interrupters (GFCI) are **NOT RECOMMENDED. DO NOT use an extension cord or adapter plug.**
- If voltage varies by 10% or more, freezer performance may be affected. Operating freezer with insufficient power can damage the motor. Such damage is not covered under the warranty. If you suspect your house hold voltage is high or low, consult your power company for testing.
- To prevent the freezer from being turned off accidentally, do not plug unit into an outlet controlled by a wall switch or pull cord.
- Do not pinch, knot, or bend the cord in any manner.

### ⚠ WARNING Other Precautions

- To defrost the freezer, always **UNPLUG** the unit first.
- Never unplug the freezer by pulling on the cord. Always grip the plug firmly, and pull straight out from the receptacle.
- Turning the temperature control to OFF turns off the compressor, but does not disconnect the power to other electrical components.

## Set-Up Instructions

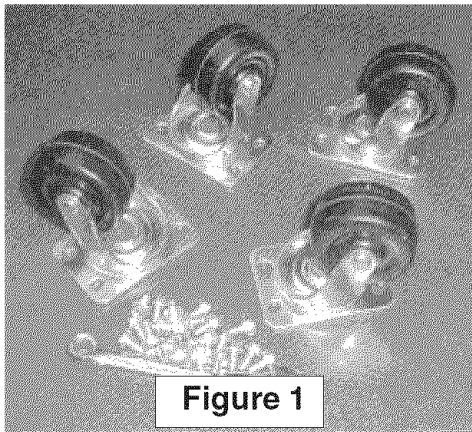

Figure 1

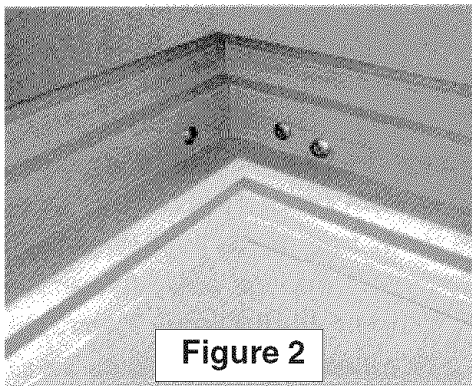

Figure 2

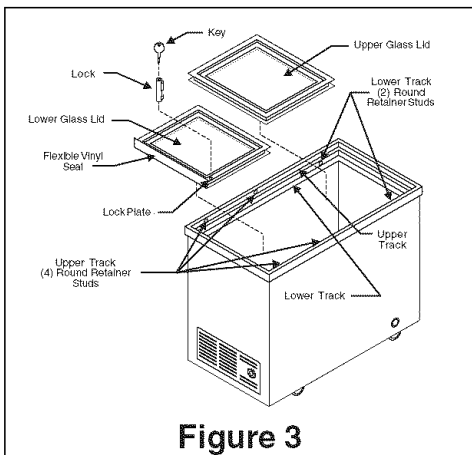

Figure 3

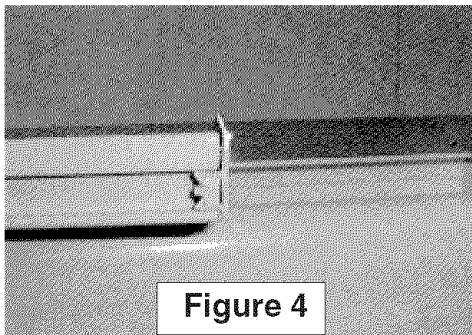

Figure 4

Before starting the freezer, follow these important first steps:

### Inspection for Damage

Inspect the freezer and packaging for damage such as a fork truck can cause, or look for bent corners from dropping the cabinet. If hidden damage is found after uncrating, immediately call the delivery carrier and request an inspection. Retain all packaging and crating materials until the inspection is complete.

### Uncrating and Set-Up

- Using a utility knife with a sharp, short blade, cut along the perimeter of the carton as indicated.
- Lift the carton off the freezer.
- Using a pair of wire cutters, carefully snip the cable tie from the basket. Set the basket to the side.
- Remove the cardboard box containing the glass lid and casters from the freezer. This box will contain the following items:
  - One (1) wrench
  - Sixteen (16) screws
  - Four (4) casters
  - One (1) upper glass lid
  - One (1) lower glass lid

### Casters

- With an assistant, tilt the freezer until it is resting on its back. Take care to protect the back from being scratched during this process.
- Using the wrench provided and the (16) sixteen screws (Figure 1), install all (4) four casters in the tapping holes in the bottom of the unit. Tighten securely.
- With an assistant, tilt the freezer back up onto the casters.
- Return the wire basket to the unit, resting it on the side rails of the freezer.

### Glass Lid

- There are two glass lids, a smaller one that fits in the lower track of the freezer and a larger one that fits in the upper track. The lower track has two (2) round retaining studs and the upper has four (4) round retaining studs (Figure 2).
- Install the lower glass first. Again, the lower glass is the smaller of the two. It has a flexible vinyl seal (Figure 4) and a lock plate. The flexible seal should be facing up and positioned on the end away from the two (2) round retaining studs. Place the panel in the center and slide along the lower track until it is secure under the two retaining studs.
- Place the upper glass panel over the lower glass panel already in place. Slide it over the lower lid past the flexible seal. You will notice a slight resistance with the lower lid gasket. Slide the upper panel under the four (4) studs on the upper track of the frame.
- When properly installed, there is a seal formed by the flexible vinyl seal between the two glass lids.

---

## Set-Up Instructions (continued)

### Lock

- To lock the glass lid, simply insert the key and lock into the lock plate. Turn key clockwise. Remove key and store in safe place.

### Installation

- Roll the unit to the place where it will be installed. If the floor is not flat and level, the unit may tip from side to side. If it does tip, take the time to level the unit.
- Choose a place that is near a grounded electrical outlet.
- For the most efficient operation, the freezer should be located where surrounding temperatures will not exceed 110°F (43°C). Temperatures of 32°F (0°C) and below will NOT affect freezer operation. Additional compressor heaters are not recommended.
- Locate the freezer out of direct sunlight.
- **Allow space around the unit for good air circulation.** Leave a 3 inch (75 mm) space on all sides of the freezer for adequate circulation.

### Cleaning

- Wash any removable parts, the freezer interior, and exterior with mild detergent. Wipe Dry. **DO NOT USE HARSH CLEANERS ON THESE SURFACES. DO NOT WASH REMOVABLE PARTS IN DISHWASHER.**
- Do not use razor blades or other sharp instruments, which can scratch the appliance surface when removing adhesive labels. Any glue left from the tape can be removed with a mixture of warm water and mild detergent, or touch the residue with the sticky side of the tape already removed. **DO NOT REMOVE THE SERIAL PLATE.**

---

## Please Note

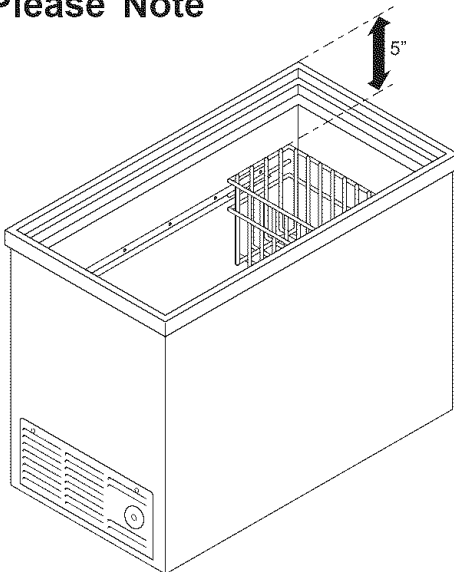

For maximum cooling efficiency DO NOT store product about the height of the basket installed in the unit (approximately 5 inches down from the top of the frame).

## Setting the Temperature Control

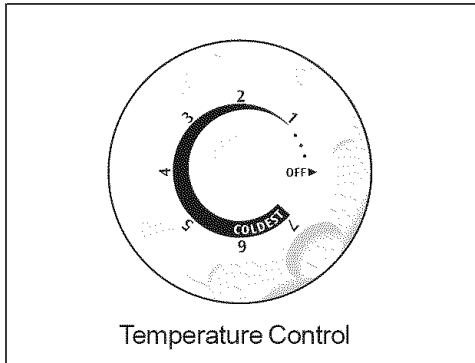

### Cool Down Period

Once the appliance has been located in its permanent location, check to be sure the proper power and grounding have been provided. For safe storage, allow 4 hours for freezer to cool down completely. The freezer will run continuously for the first several hours.

### Temperature Control

The temperature control is located inside the freezer on upright models, and on the left outside wall on chest models. The temperature is factory preset to provide satisfactory food storage temperatures. However, the temperature control is adjustable to provide a range of temperatures for your personal satisfaction. If a colder temperature is desired, turn the temperature control knob toward COLDEST and allow several hours for temperatures to stabilize between adjustments.

## Freezer Features

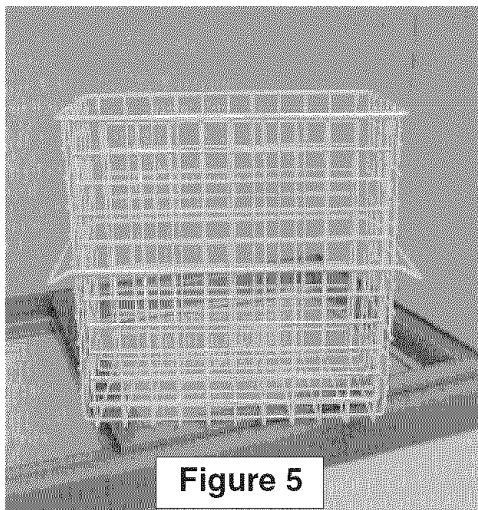

### Defrost Drain

The defrost drain provides a method of draining water during defrosting and cleaning. See "Defrosting" in the Care and Cleaning Section.

### Sliding Basket (Some Models)

Makes locating and retrieving stored items easier. Helps segregate food items into groups. Baskets are epoxy powder coated. This finish is extremely durable and will not chip, crack or discolor in freezing temperatures. Won't stain and can be easily cleaned (Figure 5).

### Lock

Allows the unit to be locked for safety and protection (Figure 6).

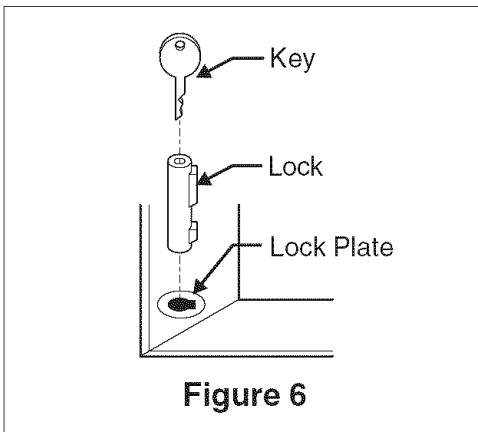

### Casters

Allows the unit to be easily rolled out of the way for cleaning or moving.

## Care and Cleaning

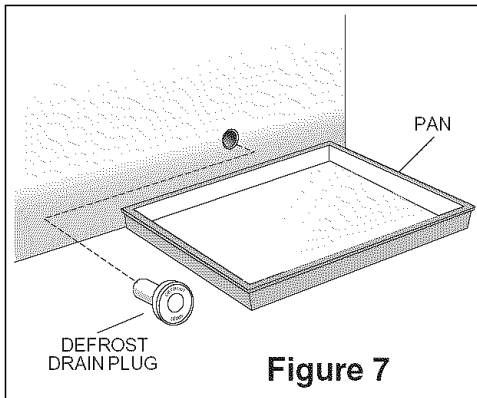

Figure 7

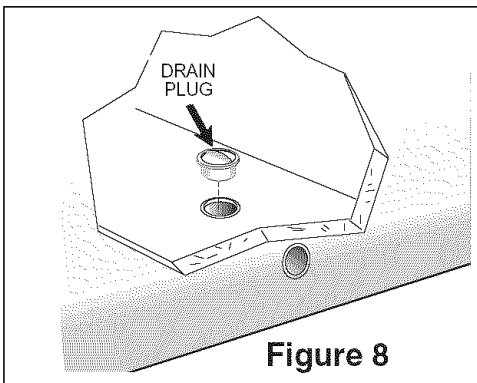

Figure 8

### Between Defrostings

To avoid frequent defrosting, occasionally use a plastic scraper to remove frost. Scrape with a pulling motion. Never use a metal instrument to remove frost.

### Defrosting

#### CAUTION

Freezer must be unplugged (to avoid electrical hazard) from power source when defrosting unit.

It is important to defrost and clean freezer when  $\frac{1}{4}$  to  $\frac{1}{2}$  inch of frost has accumulated. Frost may tend to accumulate faster on upper part of the freeze due to warm, moist air entering the freezer when the door is opened. Remove food and leave the door open when defrosting the freezer.

To use the defrost drain, place a shallow pan beneath the drain outlet (Figure 7). Pull out the drain plug inside the freezer, and pull off the outside defrost drain plug (Figure 8). Defrost water will drain out. Check pan occasionally so water does not overflow. Replace the drain plugs when defrosting is completed.

If the frost is soft, remove it by using a plastic scraper. If the frost is glazed and hard, fill deep pans with hot water and place them on the freezer bottom. Close the freezer door. Frost should soften in about 15 minutes. Repeat this procedure if necessary.

### Cleaning

After defrosting, wash inside and outside surfaces of the freezer with a solution of two tablespoons of baking soda in one quart or one liter of warm water. Rinse and dry. Wring excess water out of the sponge or cloth when cleaning in the area of the controls, or any electrical parts.

Wash the removable parts with the baking soda solution mentioned above, or mild detergent and warm water. Rinse and dry. **Never** use metallic scouring pads, brushes, abrasive cleaners, or alkaline solutions on any surface. **DO NOT** wash removable parts in a dishwasher. Replace parts and food.

## Power Failure

Do not open freezer lid unnecessarily if freezer is off for several hours.

If a power failure occurs, pack seven or eight pounds of dry ice into the freezer every 24 hours. Look in the Yellow Pages under "Dry Ice", "Dairies", or "Ice Cream Manufacturers" for local dry ice suppliers. Always wear gloves and use caution when handling dry ice.

## Energy Saving Idea

The freezer should be located in the coolest area in the room, away from heat producing appliances or heating ducts, and out of direct sunlight.

# IMPORTANT SAFETY NOTICE

The information provided herein is designed to assist qualified repair personnel only. Untrained persons should not attempt to make repairs due to the possibility of electrical shock. Disconnect the power cord before servicing.

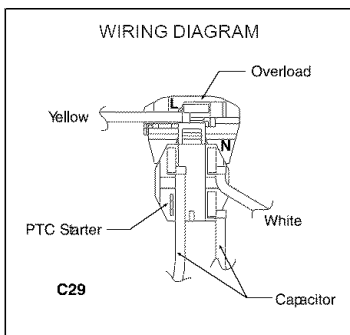
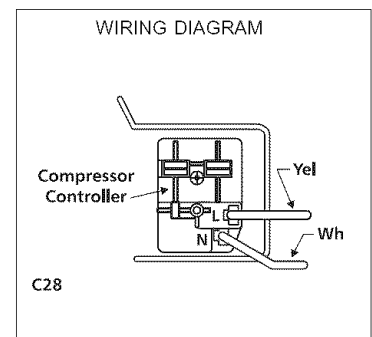
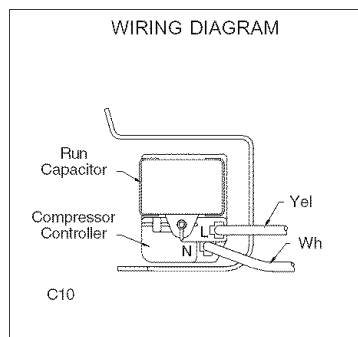
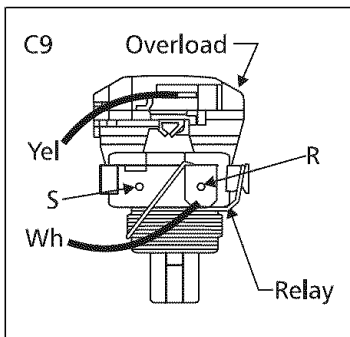
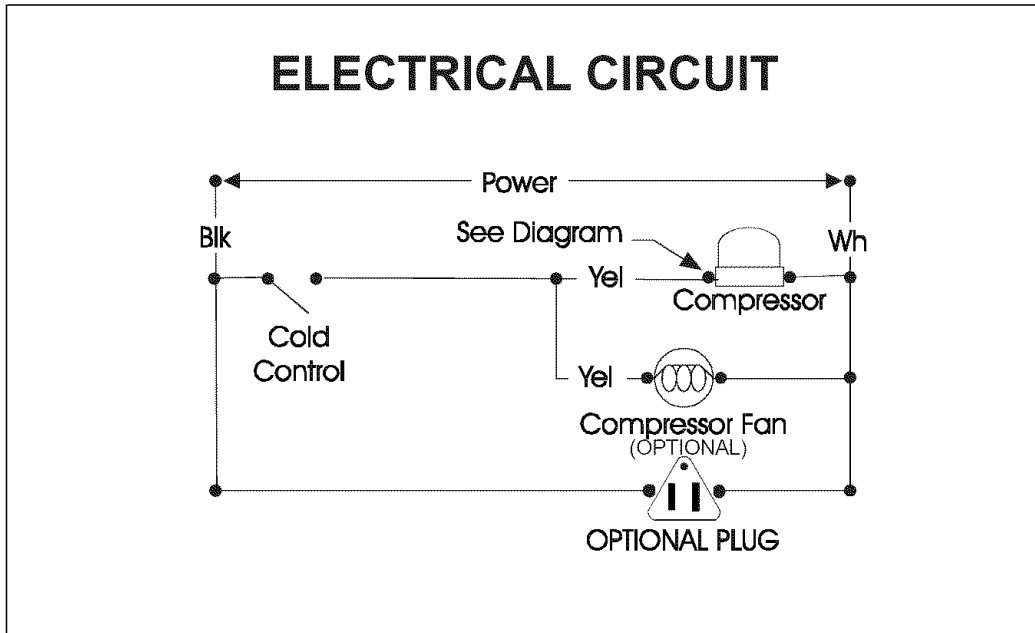

**IMPORTANT**  
 If any green grounding wires are removed during servicing, they must be returned to their original position and properly secured.

# Dimensional Drawings

∞

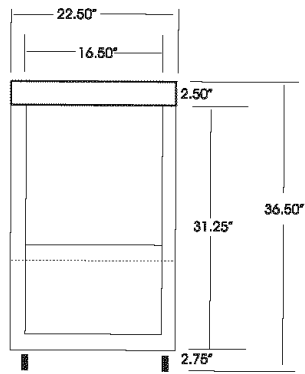

SIDE

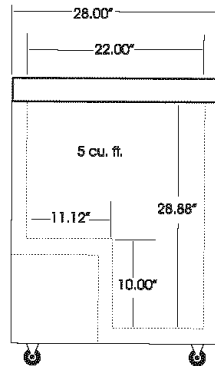

FRONT  
ST05G

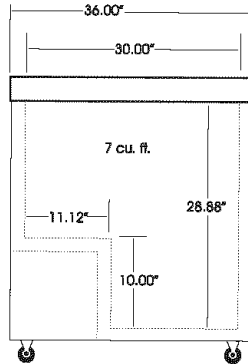

FRONT  
ST07G

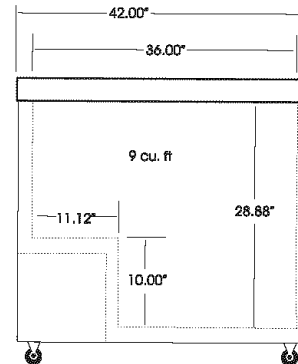

FRONT  
ST09G

FOR PROPER AIR CIRCULATION,  
ALLOW 3" AT EACH END AND BACK  
SIDE OF FREEZER.

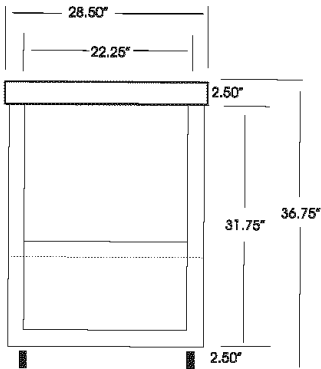

SIDE

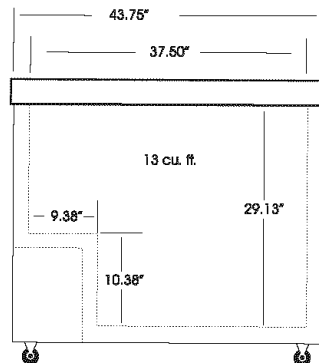

FRONT  
ST13G

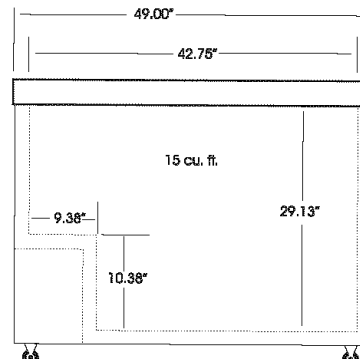

FRONT  
ST15G

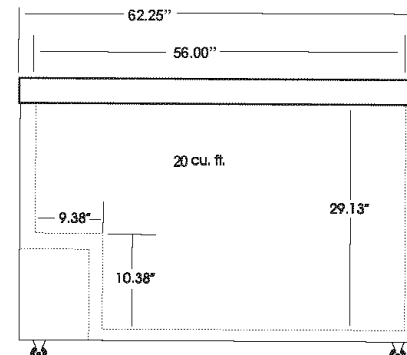

FRONT  
ST20G



# ARCTIC AIR COMMERCIAL REFRIGERATOR/FREEZER WARRANTY

**ARCTIC AIR (Division of Broich Enterprises, Inc.)** warrants every new refrigerator and freezer to be free from defects in material or workmanship for a period of **one (1) year** (except as noted in the Special Mobile Use Warranty below) from the earliest of either: 1) the date of original purchase or; 2) fifteen (15) months after the manufacturer's ship date of the product (warranty period).

This warranty provides:

**A. PARTS WARRANTY**

**ARCTIC AIR** will, at its option, repair or replace any part(s), that are found defective during the warranty period. In addition, **ARCTIC AIR** warrants that the **compressor** shall be free from defects for an additional **four (4) years** beyond the expiration of the warranty period or for a total period of **five (5) years**.

Warranty replacement parts must be arranged by calling the **Customer Service Center** at **1-800-490-9574** ( in the United States and Puerto Rico ) and **1-866-294-9911** ( in Canada ).

**B. LABOR WARRANTY**

**ARCTIC AIR** will, at its option, provide or pay for the labor to repair or replace the part(s) or product defect during the warranty period. Warranty labor must be arranged by calling the **Customer Service Center** at **1-800-490-9574** ( in the United States and Puerto Rico ) and **1-866-294-9911** ( in Canada ).

**C. SPECIAL MOBILE USE WARRANTY**

**ARCTIC AIR** warrants every new refrigerator and freezer operated by a concessionaire or vendor in a trailer, motorized vehicle or at varying locations for a period of **one (1) year** for the part(s) and **ninety (90) days** for labor to repair or replace, at **Arctic Air's** option, the warranty part(s). In addition, **ARCTIC AIR** warrants that the **compressor** shall be free from defects for a total period of **five (5) years**. This warranty will be effective with the earliest of either: 1) the date of original purchase or; 2) fifteen (15) months after the manufacturer's ship date of the product. Any labor to remove or expose or make the refrigerator or freezer available for service under this warranty shall be at the user's expense.

**D. CONDITIONS**

Service under this warranty must be performed by a preferred service company arranged by the **Customer Service Center** at **1-800-490-9574** ( in the United States and Puerto Rico ) and **1-866-294-9911** ( in Canada ). The user must give the preferred service company prompt notice and access to the product when service is needed.

**E. LIMITATIONS AND EXCLUSIVE WARRANTY**

Normal wear and tear and gradual deterioration is excluded from this warranty. This parts and labor warranty is the sole and exclusive warranty remedy offered by **ARCTIC AIR**. **ALL OTHER WARRANTIES, EITHER EXPRESS OR IMPLIED, ARISING UNDER LAW OR EQUITY OR CUSTOM OF THE TRADE INCLUDING BUT NOT LIMITED TO WARRANTIES OR MERCHANTABILITY OR FITNESS FOR A PARTICULAR PURPOSE ARE EXCLUDED. NEITHER ARCTIC AIR NOR ITS SERVICING AGENT SHALL BE LIABLE FOR ANY INCIDENTAL OR CONSEQUENTIAL LOSS OR DAMAGES (INCLUDING BUT NOT LIMITED TO FOOD OR PRODUCT LOSS, PERSONAL INJURY OR PROPERTY DAMAGE) WHETHER BASED ON CONTRACT OR TORT (INCLUDING NEGLIGENCE AND STRICT LIABILITY) ARISING OUT OF THE EQUIPMENT OR SERVICE PROVIDED HEREUNDER. THIS WARRANTY DOES NOT APPLY TO ARCTIC AIR PRODUCTS SOLD OUTSIDE THE UNITED STATES, CANADA, OR PUERTO RICO. THIS WARRANTY DOES NOT COVER:**

- **FREIGHT DAMAGE**
- **FOOD LOSS**
- **NON-FACTORY APPROVED REVISIONS OR MODIFICATIONS**