

Digital Video Camera Recorder 8

Operating Instructions

Before operating the unit, please read this manual thoroughly, and retain it for future reference.

Owner's Record

The model and serial numbers are located on the bottom. Record the serial number in the space provided below. Refer to these numbers whenever you call upon your Sony dealer regarding this product.

Model No. **DCR-TRV130**

Model No. **AC-**_____

Serial No. _____ Serial No. _____

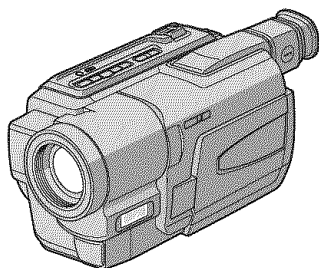

Digital Handycam

 InfoLITHIUM™  L
SERIES



Digital 8
DCR-TRV130

Welcome!

Congratulations on your purchase of this Sony Digital Handycam camcorder. With your Digital Handycam, you can capture life's precious moments with superior picture and sound quality. Your Digital Handycam is loaded with advanced features, but at the same time it is very easy to use. You will soon be producing home video that you can enjoy for years to come.

WARNING

To prevent fire or shock hazard, do not expose the unit to rain or moisture.

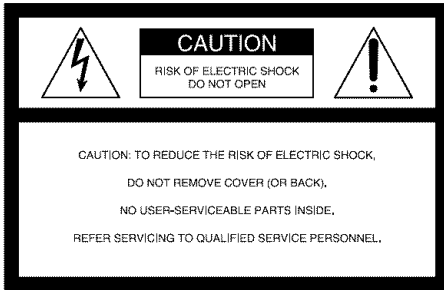

This symbol is intended to alert the user to the presence of uninsulated "dangerous voltage" within the product's enclosure that may be of sufficient magnitude to constitute a risk of electric shock to persons.



This symbol is intended to alert the user to the presence of important operating and maintenance (servicing) instructions in the literature accompanying the appliance.

Never expose the battery pack to temperatures above 60°C (140°F) such as in a car parked in the sun or under direct sunlight.

For customers in the United States and Canada

DISPOSAL OF LITHIUM ION BATTERY. LITHIUM ION BATTERY. DISPOSE OF PROPERLY.

You can return your unwanted lithium ion batteries to your nearest Sony Service Center or Factory Service Center.

Note: In some areas the disposal of lithium ion batteries in household or business trash may be prohibited.

For the Sony Service Center nearest you call 1-800-222-SONY (United States only)

For the Sony Factory Service Center nearest you call 416-499-SONY (Canada only)

Caution: Do not handle damaged or leaking lithium ion battery.

For customers in the U.S.A.

If you have any questions about this product, you may call:
Sony Customer Information Center 1-800-222-SONY (7669)
The number below is for the FCC related matters only.

Regulatory Information

Declaration of Conformity

Trade Name: SONY
Model No.: DCR-TRV130
Responsible Party: Sony Electronics Inc.
Address: 1 Sony Drive, Park Ridge, NJ, 07656 USA
Telephone No.: 201-930-6972

This device complies with Part15 of the FCC Rules. Operation is subject to the following two conditions.: (1) This device may not cause harmful interference, and (2) this device must accept any interference received, including interference that may cause undesired operation.

CAUTION

You are cautioned that any changes or modifications not expressly approved in this manual could void your authority to operate this equipment.

Note:

This equipment has been tested and found to comply with the limits for a Class B digital device, pursuant to Part 15 of the FCC Rules. These limits are designed to provide reasonable protection against harmful interference in a residential installation. This equipment generates, uses, and can radiate radio frequency energy and, if not installed and used in accordance with the instructions, may cause harmful interference to radio communications. However, there is no guarantee that interference will not occur in a particular installation. If this equipment does cause harmful interference to radio or television reception, which can be determined by turning the equipment off and on, the user is encouraged to try to correct the interference by one or more of the following measures:

- Reorient or relocate the receiving antenna.
- Increase the separation between the equipment and receiver.
- Connect the equipment into an outlet on a circuit different from that to which the receiver is connected.
- Consult the dealer or an experienced radio/TV technician for help.

For customers in CANADA**CAUTION**

TO PREVENT ELECTRIC SHOCK, MATCH
WIDE BLADE OF PLUG TO WIDE SLOT,
FULLY INSERT.

Main Features

Functions to adjust exposure (in the recording mode)

- In a dark place NIGHTSHOT (p. 24)/
SUPER NIGHTSHOT (p. 25)
- In insufficient light Low lux mode (p. 44)
- In dark environments such as sunset, fireworks,
or general night views Sunset & moon mode (p. 44)
- Shooting backlit subjects BACK LIGHT (p. 24)
- In spotlight, such as at the theater Spotlight mode (p. 44)
- In strong light or reflected light, such as
at a beach in midsummer or on a ski slope Beach & ski mode (p. 44)

Functions to give images more impact (in the recording mode)

- Smooth transition between scenes FADER (p. 37)
- Taking a still image Tape photo recording (p. 34)
- Digital processing of images PICTURE EFFECT (p. 40)/
DIGITAL EFFECT (p. 41)
- Creating a soft background for subjects Soft portrait mode (p. 44)
- Superimposing a title TITLE (p. 48)

Functions to give a natural appearance to your recordings (in the recording mode)

- Preventing deterioration of picture quality
in digital zoom D ZOOM [MENU] (p. 80)
The default setting is set to **OFF**.
(To zoom greater than 20 \times , select the digital
zoom power in **D ZOOM** in the menu settings.)
- Focusing manually Manual focus (p. 47)
- Shooting distant subjects Landscape mode (p. 44)
- Recording fast-moving subjects Sports lesson mode (p. 44)

Functions to use in editing (in the recording mode)

- Watching the picture on a wide-screen TV Wide mode (p. 36)

Functions to use after recording (in the playback mode)

- Digital processing of recorded images PICTURE EFFECT (p. 55)/
DIGITAL EFFECT (p. 56)
- Displaying the date/time or recording data
when you recorded Data code (p. 28)
- Quickly locating a desired scene Zero set memory (p. 58, 78)
- Searching for scenes recorded on tape in
the photo mode Photo search (p. 61)
- Scanning scenes recorded on tape in
the photo mode Photo scan (p. 62)
- Playing back on monaural sound or sub sound HiFi SOUND [MENU] (p. 81)
- Playing back the picture on a TV without
connecting a cord SUPER LASER LINK (p. 32)

Table of contents

Main Features	4
---------------------	---

Quick Start Guide	6
--------------------------------	---

Getting started

Using this manual	8
Checking supplied accessories	10
Step 1 Preparing the power supply ...	11
Installing the battery pack	11
Charging the battery pack	12
Connecting to a wall outlet	15
Step 2 Setting the date and time	16
Step 3 Inserting a cassette	17

Recording – Basics

Recording a picture	18
Shooting backlit subjects	
– BACK LIGHT	24
Shooting in the dark	
– NightShot/Super NightShot	
.....	24
Checking the recording	
– END SEARCH	26

Playback – Basics

Playing back a tape	27
Viewing the recording on TV	31

Advanced Recording Operations

Recording a still image on a tape	
– Tape Photo recording	34
Using the wide mode	36
Using the fader function	37
Using special effects – Picture effect ..	40
Using special effects – Digital effect ...	41
Using the PROGRAM AE function	44
Adjusting the exposure manually	46
Focusing manually	47
Superimposing a title	48
Making your own titles	50
Using the built-in light	52

Advanced Playback Operations

Playing back a tape with picture effects	55
Playing back a tape with digital effects	56
Enlarging images recorded on tapes	
– Tape PB ZOOM	57
Quickly locating a scene using the zero set memory function	58
Searching a recording by date	
– Date search	59
Searching for a photo	
– Photo search/Photo scan	61

Editing

Dubbing a tape	63
Dubbing only desired scenes	
– Digital program editing	65
Recording from video	76
Inserting a scene from a VCR	
– Insert Editing	77

Customizing Your Camcorder

Changing the menu settings	79
----------------------------------	----

Troubleshooting

Types of trouble and their solutions ..	85
Self-diagnosis display	89
Warning indicators and messages	90

Additional Information

About video cassettes	92
About the “InfoLITHIUM” battery pack	93
About i.LINK	94
Using your camcorder abroad	96
Maintenance information and precautions	97
Specifications	102

Quick Reference

Identifying the parts and controls	103
Index	110

Quick Start Guide



This chapter introduces you to the basic features of your camcorder. See the page in parentheses “()” for more information.

1 Connecting the power cord (p. 15)

Use the battery pack when using your camcorder outdoors (p. 11).

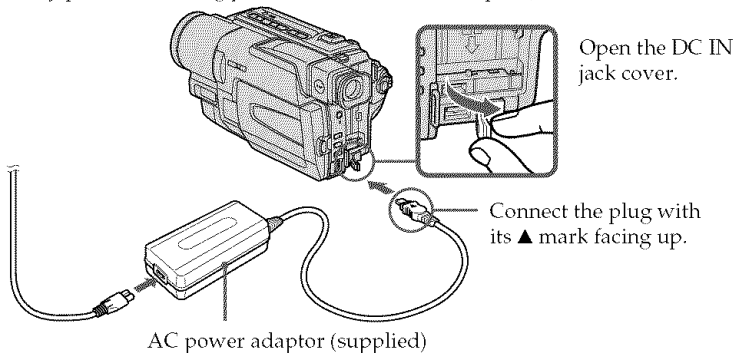

2 Inserting a cassette (p. 17)

1 Open the lid of the cassette compartment, and press EJECT. The compartment opens automatically.



2 Insert a cassette into the cassette compartment with its window facing out and the write-protect tab on the cassette up.

3 Close the cassette compartment by pressing the **PUSH** mark on the cassette compartment. The cassette compartment automatically goes down. Close the lid of the cassette compartment.

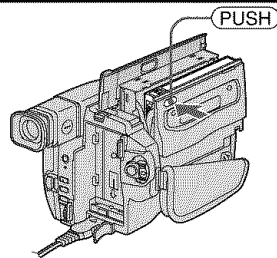
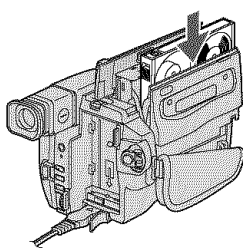
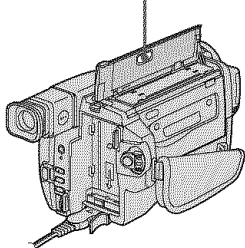

3

Recording a picture (p. 18)

- 1 Remove the lens cap.

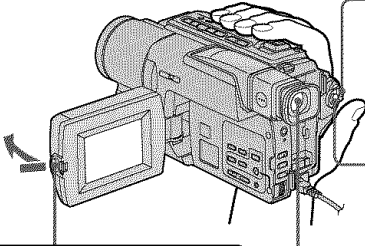

- 3 Open the LCD panel while pressing OPEN. The picture appears on the LCD screen.

Viewfinder

When the LCD panel is closed, use the viewfinder placing your eye against its eyecup.

The picture in the viewfinder is black and white.

- 2 Set the POWER switch to CAMERA while pressing the small green button.

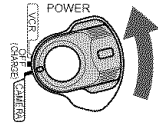

- 4 Press the red button. Your camcorder starts recording. To stop recording, press the red button again.

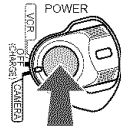

When you purchase your camcorder, the clock setting is set to off. If you want to record the date and time for a picture, set the clock setting before recording (p. 16).

4

Monitoring the playback picture on the LCD screen (p. 27)

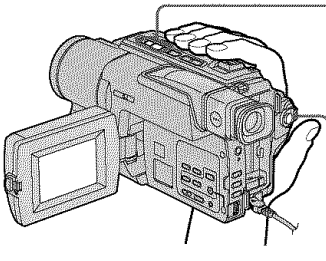

- 1 Set the POWER switch to VCR while pressing the small green button.

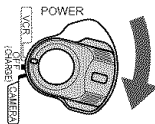

- 2 Press ◀◀ to rewind the tape.



- 3 Press ▶▶ to start playback.



Note

Do not pick up your camcorder by holding the viewfinder, the LCD panel, or the battery pack.

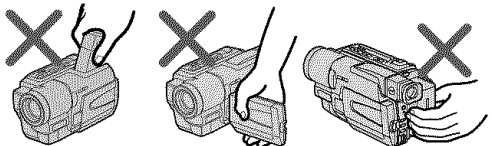

Using this manual

As you read through this manual, buttons and settings on your camcorder are shown in capital letters.

e.g. Set the POWER switch to CAMERA.

When you carry out an operation, you can hear a beep sound to indicate that the operation is being carried out.

Before using your camcorder

With your digital camcorder, we recommend using Hi8 **Hi8**/Digital8 **D8** video cassettes. Your camcorder records and plays back pictures only in the Digital8 **D8** system. You cannot play back tapes recorded in the Hi8 **Hi8**/standard 8 **8** (analog) system.

Note on TV color systems

TV color systems differ from country to country. To view your recordings on a TV, you need an NTSC system-based TV.

Copyright precautions

Television programs, films, video tapes, and other materials may be copyrighted. Unauthorized recording of such materials may be contrary to the provision of the copyright laws.

Precautions on camcorder care

Lens and LCD screen/finder (on mounted models only)

- The LCD screen and the finder are manufactured using extremely high-precision technology so over 99.99% of the pixels are operational for effective use. However, there may be some tiny black points and/or bright points (white, red, blue or green in color) that constantly appear on the LCD screen and the finder. These points are normal in the manufacturing process and do not affect the recording in any way.
- Do not let your camcorder get wet. Keep your camcorder away from rain and sea water. Letting your camcorder get wet may cause your camcorder to malfunction. Sometimes this malfunction cannot be repaired **[a]**.
- Never leave your camcorder exposed to temperatures above 60°C (140°F), such as in a car parked in the sun or under direct sunlight **[b]**.
- Be careful when placing the camera near a window or outdoors. Exposing the LCD screen, the finder or the lens to direct sunlight for long periods may cause malfunctions **[c]**.
- Do not directly shoot the sun. Doing so might cause your camcorder to malfunction. Take pictures of the sun in low light conditions such as dusk **[d]**.

[a]

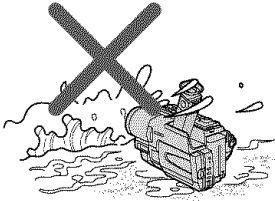

[b]

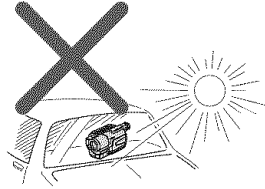

[c]

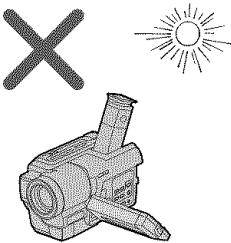

[d]

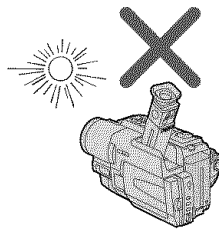

Checking supplied accessories

Make sure that the following accessories are supplied with your camcorder.

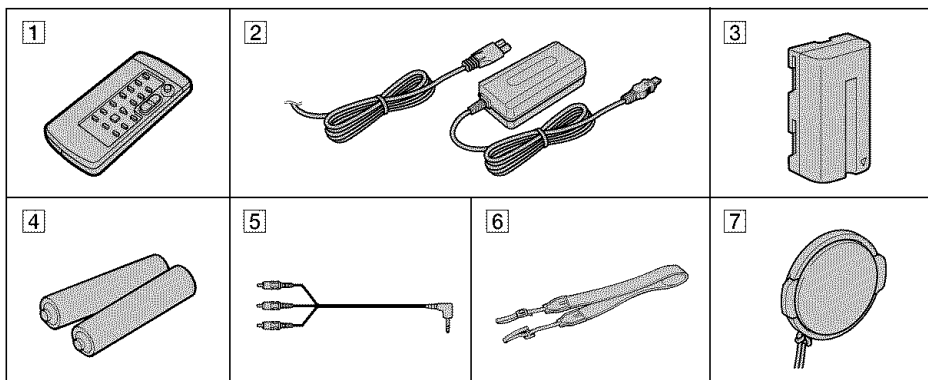

1 **Wireless Remote Commander** (1)
(p. 108)

2 **AC-L10A/L10B/L10C AC power adaptor** (1), **Power cord** (1) (p. 12)

3 **NP-F330 battery pack** (1) (p. 11, 12)

4 **Size AA (R6) battery for Remote Commander** (2) (p. 108)

5 **A/V connecting cable** (1) (p. 31)

6 **Shoulder strap** (1) (p. 105)

7 **Lens cap** (1) (p. 18, 104)

Contents of the recording cannot be compensated if recording or playback is not made due to a malfunction of the camcorder, storage media, etc.

Step 1 Preparing the power supply

Installing the battery pack

Install the battery pack to use your camcorder outdoors.

Slide the battery pack down until it clicks.

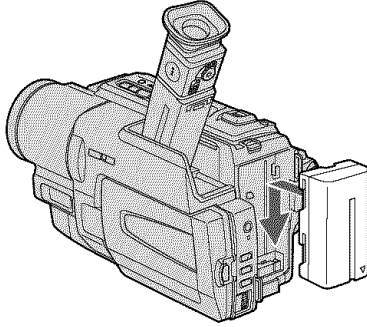

To remove the battery pack

Slide the battery pack out in the direction of the arrow while pressing BATT RELEASE down.

↓ BATT

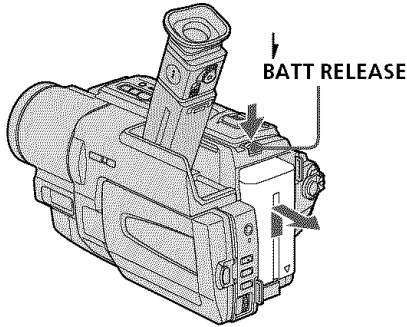

Step 1 Preparing the power supply

Charging the battery pack

Use the battery pack after charging it for your camcorder.

Your camcorder operates only with the "InfoLITHIUM" battery pack (L series). See page 93 for more information about "InfoLITHIUM" battery pack.

- (1) Open the DC IN jack cover and connect the AC power adaptor supplied with your camcorder to the DC IN jack with the plug's ▲ mark facing up.
- (2) Connect the power cord to the AC power adaptor.
- (3) Connect the power cord to a wall outlet.
- (4) Set the POWER switch to OFF (CHARGE). Charging begins, and the CHG lamp lights up.

When the CHG lamp goes out, the charging is completed.

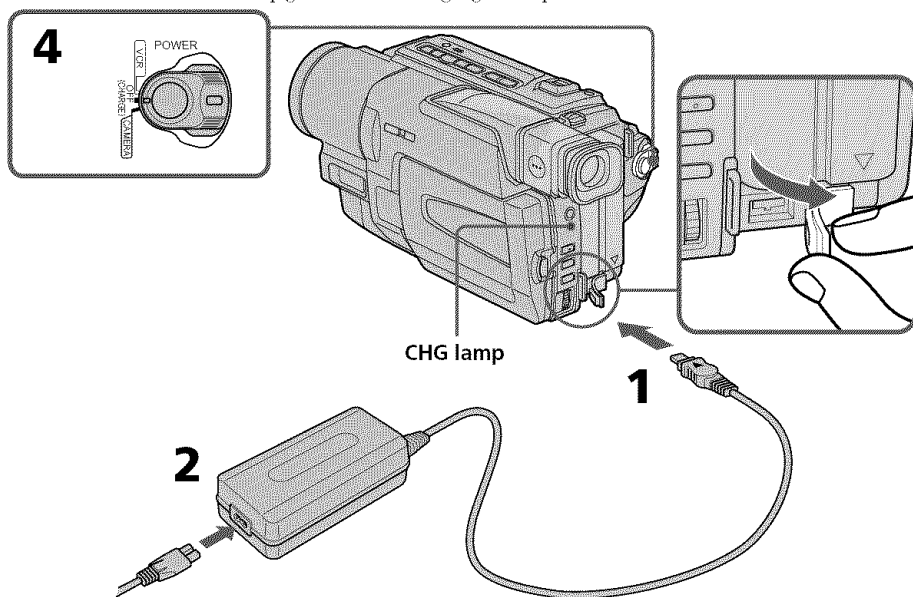

After charging the battery pack

Disconnect the AC power adaptor from the DC IN jack on your camcorder.

Notes

- Prevent metallic objects from coming into contact with the metal parts of the DC plug of the AC power adaptor. This may cause a short-circuit, damaging the AC power adaptor.
- Keep the battery pack dry.
- When the battery pack is not to be used for a long time, charge the battery pack fully, and then use it until it fully discharges again. Do this once a year. Keep the battery pack in a cool place.

When the battery pack is charged fully

The CHG lamp goes out.

Step 1 Preparing the power supply

If the battery pack is not installed properly

The CHG lamp does not light up while charging the battery pack.

If something is wrong with the battery pack

The CHG lamp flashes while charging the battery pack.

If the power goes off although the battery remaining indicator indicates that the battery pack has enough power to operate

Charge the battery pack fully again so that the indication on the battery remaining indicator is correct.

Charging time

Battery pack	Full charge
NP-F330 (supplied)	150
NP-F530/F550	210
NP-F730/F730H/F750	300
NP-F930/F950	390
NP-F960	420

Approximate charging time at 25°C (77°F)

Recording time

Battery pack	Recording with the viewfinder		Recording with the LCD screen	
	Continuous*	Typical**	Continuous*	Typical**
NP-F330 (supplied)	100	55	90	50
NP-F530	170	95	150	80
NP-F550	205	110	185	100
NP-F730	350	190	305	165
NP-F730H/F750	425	235	375	205
NP-F930	555	305	480	265
NP-F950	650	355	570	315
NP-F960	765	420	680	375

Approximate number of minutes when you use a fully charged battery pack

- * Approximate continuous recording time at 25°C (77°F). The battery life will be shorter if you use your camcorder in a cold environment.
- * Approximate number of minutes when recording while you repeat recording start/stop, zooming and turning the power on/off. The actual battery life may be shorter.

Step 1 Preparing the power supply

Playing time

Battery pack	Playing time on LCD screen	Playing time with LCD closed
NP-F330 (supplied)	105	90
NP-F530	175	150
NP-F550	210	185
NP-F730	365	305
NP-F730H/F750	440	375
NP-F930	575	480
NP-F950	675	570
NP-F960	790	680

Approximate number of minutes when you use a fully charged battery pack

Approximate playing time at 25°C (77°F). The battery life will be shorter if you use your camcorder in a cold environment.

What is "InfoLITHIUM"?

The "InfoLITHIUM" is a lithium ion battery pack which can exchange data such as battery consumption with compatible electronic equipment. This unit is compatible with the "InfoLITHIUM" battery pack (L series). Your camcorder operates only with the "InfoLITHIUM" battery. "InfoLITHIUM" battery packs have the  mark. "InfoLITHIUM" is a trademark of Sony Corporation.

Step 1 Preparing the power supply

Connecting to a wall outlet

When you use your camcorder for a long time, we recommend that you power it from a wall outlet using the AC power adaptor.

- (1) Open the DC IN jack cover, and connect the AC power adaptor to the DC IN jack on your camcorder with the plug's ▲ mark facing up.
- (2) Connect the power cord to the AC power adaptor.
- (3) Connect the power cord to a wall outlet.

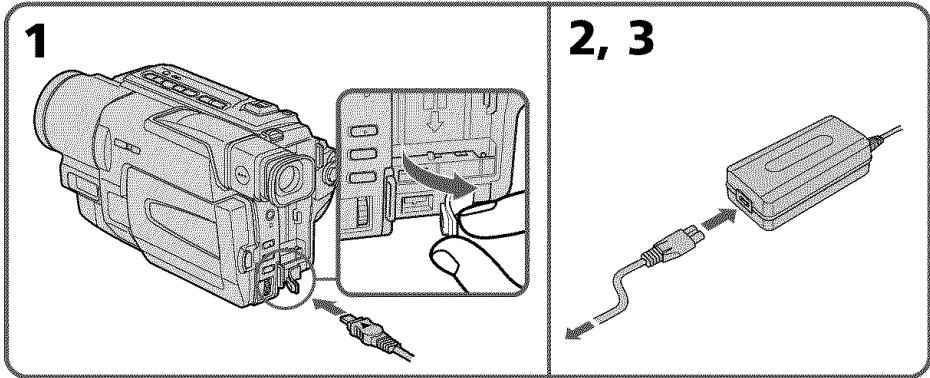

PRECAUTION

The set is not disconnected from the AC power source (wall outlet) as long as it is connected to the wall outlet, even if the set itself has been turned off.

Notes

- The AC power adaptor can supply power even if the battery pack is attached to your camcorder.
- The DC IN jack has "source priority". This means that the battery pack cannot supply any power if the power cord is connected to the DC IN jack, even when the power cord is not plugged into a wall outlet.
- Place the AC power adaptor near a wall outlet.
While using the AC power adaptor, if any trouble occurs with this unit, disconnect the plug from the wall outlet as soon as possible to cut off the power.

Using a car battery

Use Sony DC Adaptor/Charger (optional).

Step 2 Setting the date and time

Set the date and time settings when you use your camcorder for the first time.

If you do not use your camcorder for about 4 months, the date and time settings may be released (bars may appear) because the built-in rechargeable lithium cell will have been discharged.

First, set the year, then the month, the day, the hour and then the minute.

- (1) While the camcorder is in CAMERA mode, press MENU to display the menu settings.
- (2) Turn the SEL/PUSH EXEC dial to select , then press the dial.
- (3) Turn the SEL/PUSH EXEC dial to select CLOCK SET, then press the dial.
- (4) Turn the SEL/PUSH EXEC dial to adjust the desired year, then press the dial.
- (5) Set the month, day and hour by turning the SEL/PUSH EXEC dial and pressing the dial.
- (6) Set the minute by turning the SEL/PUSH EXEC dial and pressing the dial by the time signal. The clock starts to move.
- (7) Press MENU to make the menu settings disappear.

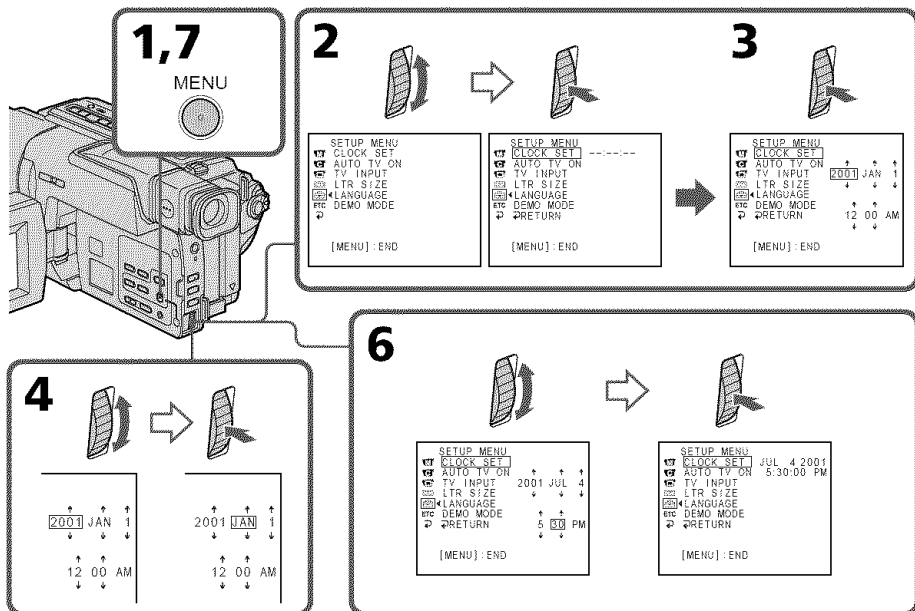

The year changes as follows:



Note on the time indicator

The internal clock of your camcorder operates on a 12-hour cycle.

- 12:00 AM stands for midnight.
- 12:00 PM stands for noon.

Step 3 Inserting a cassette

We recommend using Hi8 **Hi8**/Digital8 **D** video cassettes.

- (1) Prepare the power supply (p. 11).
- (2) Open the lid of the cassette compartment, and press EJECT. The cassette compartment opens automatically.
- (3) Insert a cassette with its window facing out and the write-protect tab on the cassette up.
- (4) Close the cassette compartment by pressing the **(PUSH)** mark on the cassette compartment. The cassette compartment automatically goes down.
- (5) Close the lid of the cassette compartment.

Getting started

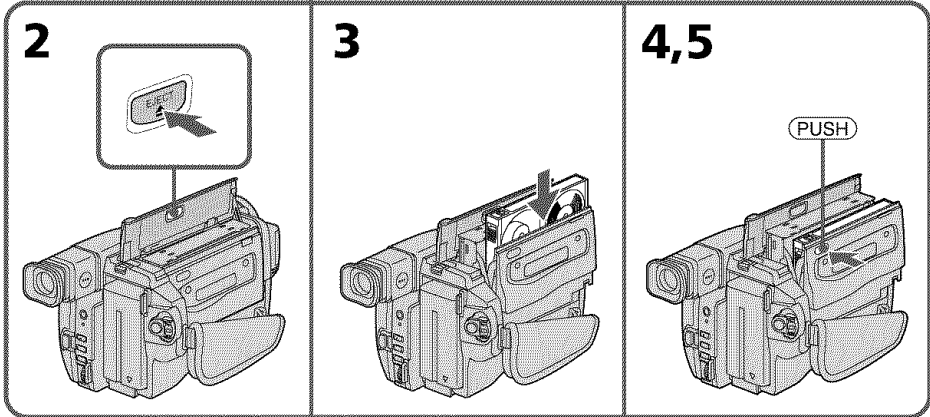

To eject a cassette

Follow the procedure above, and eject the cassette in step 3.

Notes

- Do not press the cassette compartment down. Doing so may cause a malfunction.
- Your camcorder records pictures in the Digital8 **D** system.
- The recording time when you use your camcorder is half of indicated time on Hi8 **Hi8**/Digital8 **D** tape. If you select the LP mode in the menu settings, 3/4 of indicated time on Hi8 **Hi8**/Digital8 **D** tape.
- If you use standard 8 **B** tape, be sure to play back the tape on this camcorder. Mosaic pattern noise may appear when you play back standard 8 **B** tape on other camcorders (including other DCR-TRV130).
- The cassette compartment may not be closed when you press any part of the cassette compartment other than the **(PUSH)** mark.
- Do not pick up your camcorder by holding the lid of the cassette compartment.

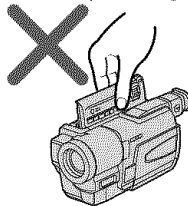

To prevent accidental erasure

Slide the write-protect tab on the cassette to expose the red mark.

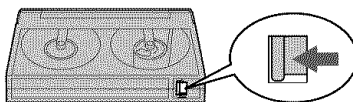

Recording a picture

Your camcorder automatically focuses for you.

- (1) Remove the lens cap by pressing both knobs on its sides and attach the lens cap to the grip strap.
- (2) Install the power source and insert a cassette. See "Step 1" to "Step 3" for more information (p. 11 to 17).
- (3) Set the POWER switch to CAMERA while pressing the small green button. Your camcorder is set to the standby mode.
- (4) Open the LCD panel while pressing OPEN. The viewfinder automatically turns off.
- (5) Press START/STOP. Your camcorder starts recording. The REC indicator appears. The camera recording lamp located on the front of your camcorder lights up. To stop recording, press START/STOP again. The recording lamp lights up in the viewfinder when you record with the viewfinder.

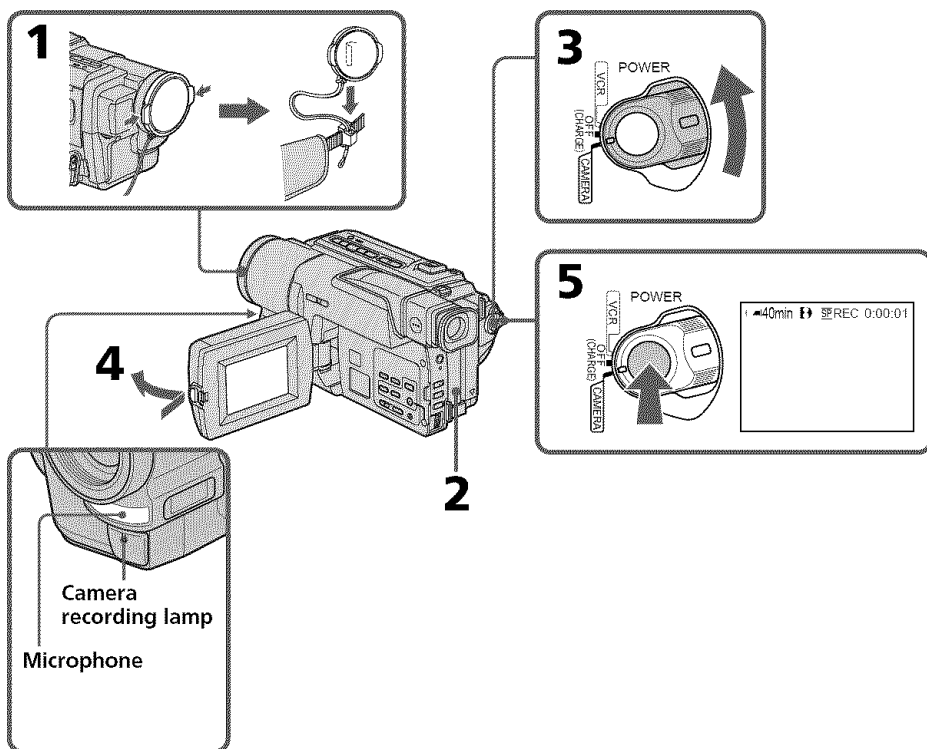

Notes

- Fasten the grip strap firmly.
- Do not touch the built-in microphone during recording.

Note on Recording mode

Your camcorder records and plays back in the SP (standard play) mode and in the LP (long play) mode. Select SP or LP in the menu settings (p. 82). In the LP mode, you can record 1.5 times as long as in the SP mode. When you record a tape in the LP mode on your camcorder, we recommend that you play back the tape on your camcorder.

Recording a picture

To enable smooth transition

You can make the transition between the last scene you recorded and the next scene smooth as long as you do not eject the cassette even if you turn off your camcorder. When you change the battery pack, set the POWER switch to OFF (CHARGE).

If you leave your camcorder in the standby mode for 3 minutes

Your camcorder automatically turns off. This is to save battery power and to prevent battery and tape wear. To resume the standby mode, set the POWER switch to OFF (CHARGE) once, then turn it to CAMERA again.

When you record in the SP and LP modes on one tape or you record some scenes in the LP mode

The playback picture may be distorted or the time code may not be written properly between scenes.

Recording date and time

The recording date and time are not displayed while recording. However, they are recorded automatically onto the tape. To display the recording date and time, press DATA CODE on the Remote Commander during playback.

Adjusting the LCD screen

The LCD panel moves about 90 degrees to the viewfinder side and about 180 degrees to the lens side.

If you turn the LCD panel over so that it faces the other way, the ☺ indicator appears on the screen (**Mirror mode**).

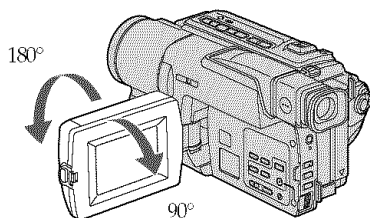

When closing the LCD panel, set it vertically until it clicks, and swing it into the camcorder body.

Note

When using the LCD screen except in the mirror mode, the viewfinder automatically turns off.

When you use the LCD screen outdoors in direct sunlight

The LCD screen may be difficult to see. If this happens, we recommend that you use the viewfinder.

Picture in the mirror mode

The picture on the LCD screen is a mirror-image. However, the picture will be normal when recorded.

During recording in the mirror mode

You cannot operate the ZERO SET MEMORY on the Remote Commander.

Indicators in the mirror mode

The STBY indicator appears as **II●** and REC as **●**. Some of other indicators appear mirror-reversed and others are not displayed.

Recording a picture

Adjusting the brightness of the LCD screen

Adjust the brightness of the LCD screen with LCD BRIGHT in  in the menu settings. (p.81)

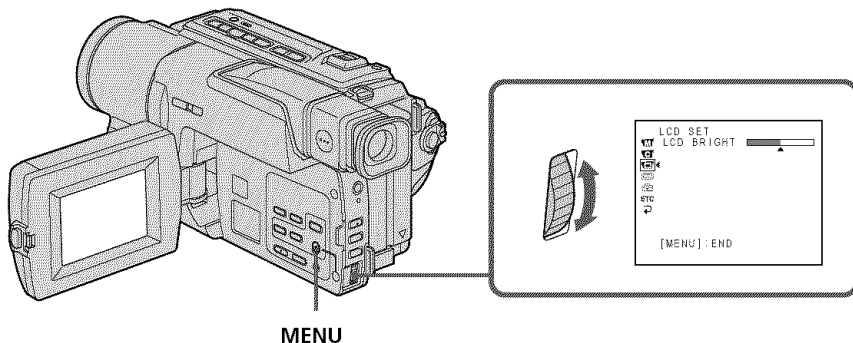

LCD screen backlight

You can adjust the brightness of the backlight. Select LCD B.L. in the menu settings (p.81).

Even if you adjust the LCD screen backlight

The recorded picture will not be affected.

After recording

- (1) Set the POWER switch to OFF (CHARGE).
- (2) Close the LCD panel.
- (3) Eject the cassette.
- (4) Attach the lens cap.

After using your camcorder

Remove the battery pack from your camcorder to avoid turning on the built-in light accidentally.

Recording a picture

Using the zoom feature

Move the power zoom lever a little for a slower zoom. Move it further for a faster zoom. Using the zoom function sparingly results in better-looking recordings.

“T” side: for telephoto (subject appears closer)

“W” side: for wide-angle (subject appears farther away)

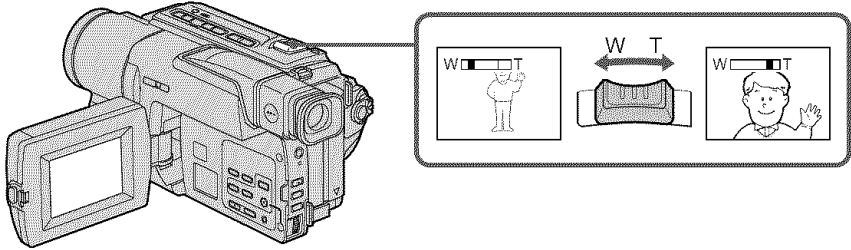

Zoom greater than 20 × is performed digitally. To activate digital zoom, select the digital zoom power in D ZOOM in the menu settings. (p. 80)

The picture quality deteriorates as the picture is processed digitally.

The right side of the bar shows the digital zooming zone.
The digital zooming zone appears when you select the digital zoom power in D ZOOM in the menu settings.

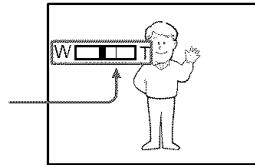

Notes on digital zoom

- Digital zoom starts to function when zoom exceeds 20 ×.
- The picture quality deteriorates as you go toward the “T” side.

When you shoot close to a subject

If you cannot get a sharp focus, move the power zoom lever to the “W” side until the focus is sharp. You can shoot a subject that is at least about 80 cm (about 2 feet 5/8 inch) away from the lens surface in the telephoto position, or about 1 cm (about 1/2 inch) away in the wide-angle position.

Recording a picture

To record pictures with the viewfinder – adjusting the viewfinder

If you record pictures with the LCD panel closed, check the picture with the viewfinder. Adjust the viewfinder lens to your eyesight so that the indicators in the viewfinder come into sharp focus.

Lift up the viewfinder and move the viewfinder lens adjustment lever.

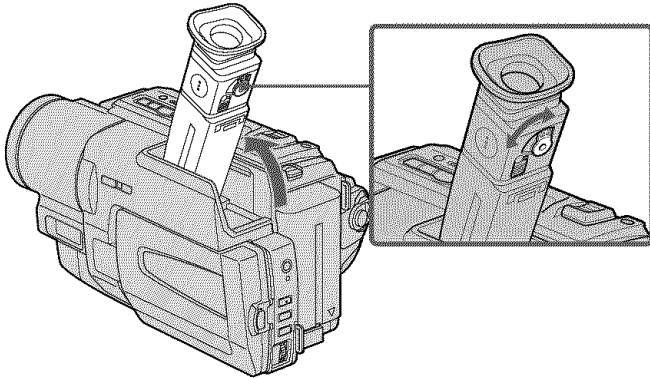

Recording a picture

Indicators displayed in the recording mode

The indicators are not recorded on tape.

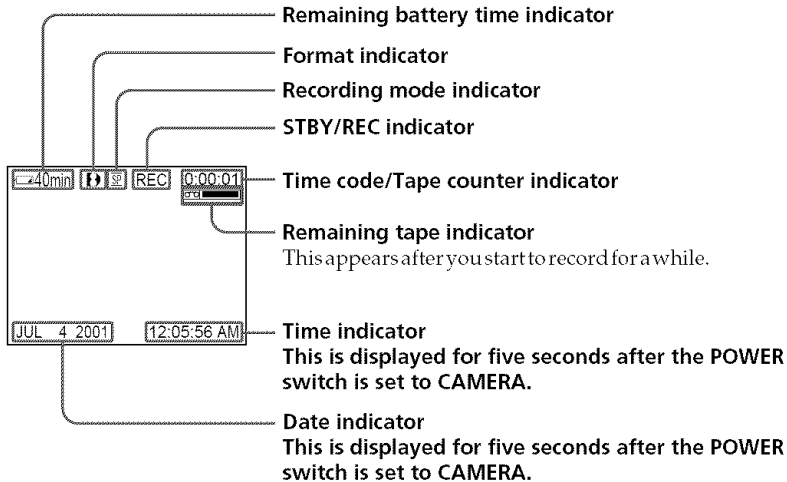

Remaining battery time indicator

The remaining battery time indicator roughly indicates the recording time. The indicator may not be correct, depending on the conditions in which you are recording. When you close the LCD panel and open it again, it takes about 1 minute for the correct remaining battery time in minutes to be displayed.

Timecode

The time code indicates the recording or playback time, "0:00:00" (hours:minutes:seconds) in CAMERA mode and "0:00:00:00" (hours:minutes:seconds:frames) in VCR mode. You cannot rewrite only the time code. You cannot reset the time code.

Recording a picture

Shooting backlit subjects – BACK LIGHT

When you shoot a subject with the light source behind the subject or a subject with a light background, use the backlight function.

Press BACK LIGHT in CAMERA mode.

The  indicator appears on the screen.

To cancel, press BACK LIGHT again.

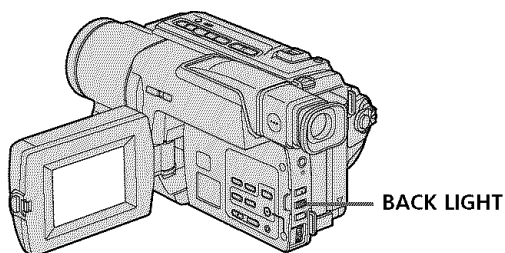

If you press EXPOSURE when shooting backlit subjects

The backlight function will be canceled.

Shooting in the dark – NightShot/Super NightShot

The NightShot function enables you to shoot a subject in a dark place. For example, you can satisfactorily record the environment of nocturnal animals for observation when you use this function.

While your camcorder is in CAMERA mode, slide NIGHTSHOT to ON.

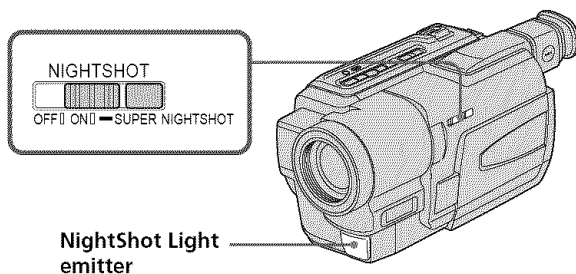

 and "NIGHTSHOT" indicators flash on the screen.

To cancel the NightShot function, slide NIGHTSHOT to OFF.



Using the Super NightShot

The Super NightShot mode makes subjects up to 16 times brighter than those recorded in the NightShot mode.

- (1) Slide NIGHTSHOT to ON in CAMERA mode.  and “NIGHTSHOT” indicators flash on the screen.
- (2) Press SUPER NIGHTSHOT.  and “SUPER NIGHTSHOT” indicators flash on the screen.

To cancel the Super NightShot mode, press SUPER NIGHTSHOT again.

Using the NightShot Light

The picture will be clearer with the NightShot Light on. To enable the NightShot Light, set N.S.LIGHT to ON in the menu settings (p. 80).

Notes

- Do not use the NightShot function in bright places (ex. outdoors in the daytime). This may cause your camcorder to malfunction.
- When you keep NIGHTSHOT setting to ON in normal recording, the picture may be recorded in incorrect or unnatural colors.
- If focusing is difficult with the autofocus mode when using the NightShot function, focus manually.

While using the NightShot function, you can not use the following functions:

- Exposure
- PROGRAM AE

While using the Super NightShot function, you can not use the following functions:

- Fader
- Digital effect
- Exposure
- PROGRAM AE

Shutter speed in the Super NightShot mode

The shutter speed will be automatically changed depending on the brightness of the background. The motion of the picture will be slow.

NightShotLight

NightShotLight rays are infrared and so are invisible. The maximum shooting distance using the NightShot Light is about 3 m (10 feet).

Checking the recording – END SEARCH

You can use this button to record a picture from the last recorded scene successively.

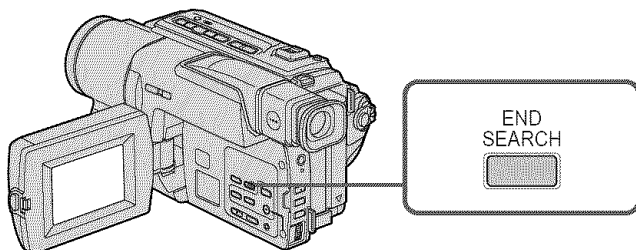

You can go to the end of the recorded section.

Press END SEARCH in CAMERA mode.

The last 5 seconds of the recorded section are played back and returns to the standby mode. You can monitor the sound from the speaker or headphones.

Notes

- If you start recording after using the end search function, occasionally, the transition between the last scene you recorded and the next scene may not be smooth.
- Once you eject the cassette after you have recorded on the tape, the end search function does not work.

If a tape has a blank portion in the recorded portions

The end search function may not work correctly.

Playing back a tape

You cannot play back the tapes recorded in the Hi8 **Hi8**/Standard **8** (analog) system. Your camcorder plays back pictures only in the Digital8 **D8** system. You can monitor the playback picture on the LCD screen. If you close the LCD panel, you can monitor the playback picture in the viewfinder. You can control playback using the Remote Commander supplied with your camcorder.

- (1) Install the power source and insert the recorded tape.
- (2) Set the POWER switch to VCR while pressing the small green button.
- (3) Open the LCD panel while pressing OPEN.
- (4) Press **REW** to rewind the tape.
- (5) Press **PLAY** to start playback.
- (6) To adjust the volume, press either of the two buttons on VOLUME. The speaker on your camcorder is silent when the LCD panel is closed.

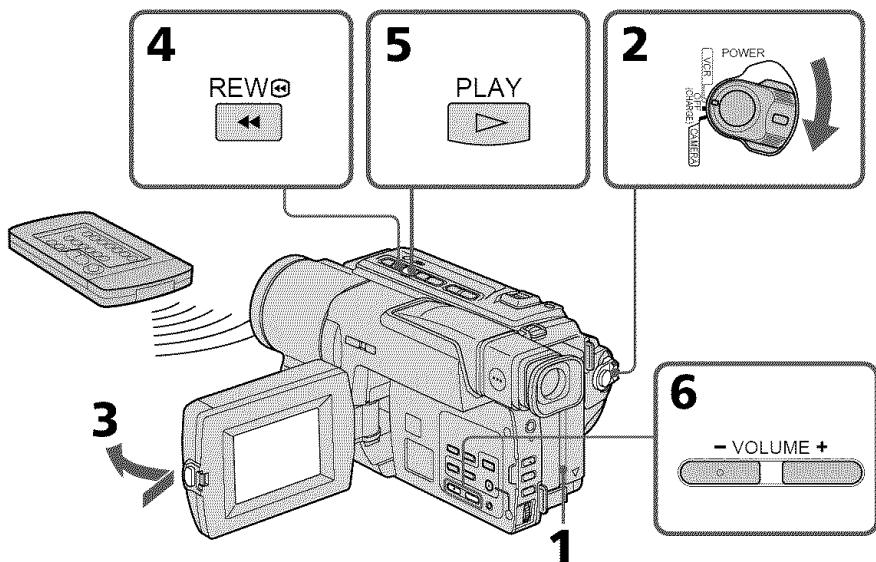

To stop playback

Press **■**.

When monitoring on the LCD screen

You can turn the LCD panel over and move it back to the camcorder body with the LCD screen facing out **[a]**. You can adjust the angle of the LCD panel by lifting the LCD panel up by 23 degrees **[b]**.

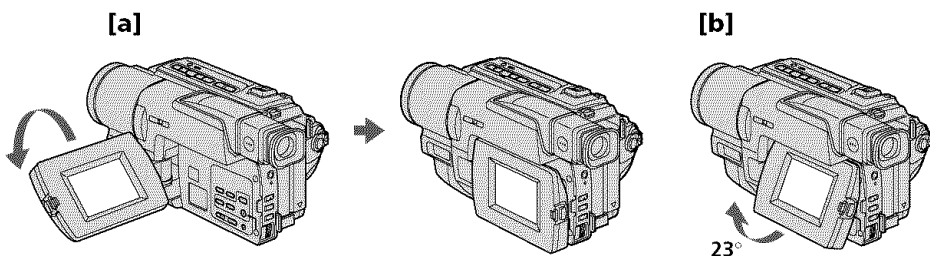

Playing back a tape

To display the screen indicators – Display function

Press DISPLAY on your camcorder or the Remote Commander supplied with your camcorder.

The indicators appear on the LCD screen.

To make the indicators disappear, press DISPLAY again.

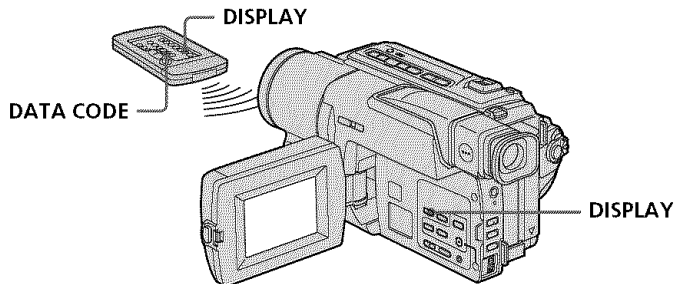

Using the data code function

Your camcorder automatically records not only images on the tape but also the recording data (date/time or various settings when recorded) (**Data code**).

Press DATA CODE on the Remote Commander in the playback mode

The display changes as follows:

date/time → various settings (SteadyShot, exposure AUTO/MANUAL, white balance, gain, shutter speed, aperture value) → no indicator

Date/time

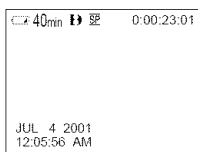

Various settings

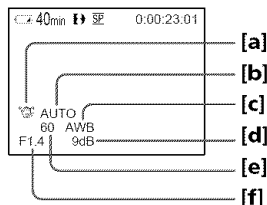

[a] : SteadyShot OFF indicator

[b] : Exposure mode indicator

[c] : White balance indicator

[d] : Gain indicator

[e] : Shutter speed indicator

[f] : Aperture value

Not to display recording date

Set DATA CODE to DATE in the menu settings (p. 82).

The display changes as follows:

date/time → no indicator

Playing back a tape

Recording data

Recording data is your camcorder's information when you have recorded. In the recording mode, the recording data will not be displayed.

When you use data code function, bars (--- -- ---- and --:--:--:) appear if:

- A blank section of the tape is being played back.
- The tape is unreadable due to tape damage or noise.
- The tape was recorded by a camcorder without the date and time set.

Data code

When you connect your camcorder to the TV, the data code appears on the TV screen.

Remaining battery time indicator during playback

The indicator indicates the approximate continuous playback time. The indicator may not be correct, depending on the conditions in which you are playing back. When you close the LCD panel and open it again, it takes about 1 minute for the correct remaining battery time to be displayed.

Playing back a tape

Various playback modes

To operate video control buttons, set the POWER switch to VCR.

To view a still image (playback pause)

Press **II** during playback. To resume playback, press **II** or **▶**.

To advance the tape

Press **▶▶** in the stop mode. To resume normal playback, press **▶**.

To rewind the tape

Press **◀◀** in the stop mode. To resume normal playback, press **▶**.

To change the playback direction

Press **<** on the Remote Commander during playback to reverse the playback direction. To resume normal playback, press **▶**.

To locate a scene monitoring the picture (picture search)

Keep pressing **◀◀** or **▶▶** during playback. To resume normal playback, release the button.

To monitor the high-speed picture while advancing or rewinding the tape (skip scan)

Keep pressing **◀◀** while rewinding or **▶▶** while advancing the tape. To resume rewinding or advancing, release the button.

To view the picture at slow speed (slow playback)

Press **▶** on the Remote Commander during playback. For slow playback in the reverse direction, press **<**, then press **▶** on the Remote Commander. To resume normal playback, press **▶**.

To view the picture at double speed

Press **×2** on the Remote Commander during playback. For double speed playback in the reverse direction, press **<**, then press **×2** on the Remote Commander. To resume normal playback, press **▶**.

To view the picture frame-by-frame

Press **II▶** on the Remote Commander in the playback pause mode. For frame-by-frame playback in the reverse direction, press **◀II**. To resume normal playback, press **▶**.

To search the last scene recorded (END SEARCH)

Press **END SEARCH** in the stop mode. The last 5 seconds of the recorded section are played back and the playback stops.

In the various playback modes

- Sound is muted.
- The previous recording may appear as a mosaic image when playing back.

Notes on the playback pause mode

- When the playback pause mode lasts for 3 minutes, your camcorder automatically enters the stop mode. To resume playback, press **▶**.
- The previous recording may appear.

Note on the slow playback mode

The slow playback can be performed smoothly on your camcorder; however, this function does not work for an output image from the **i** DV IN/OUT jack.

Viewing the recording on TV

Connect your camcorder to your TV with the A/V connecting cable supplied with your camcorder to watch the playback picture on the TV screen. You can operate the playback control buttons in the same way as when you monitor playback pictures on the LCD screen. When monitoring the playback picture on the TV screen, we recommend that you power your camcorder from a wall outlet using the AC power adaptor (p. 15). Refer to the operating instructions of your TV.

Open the jack cover. Connect your camcorder to the TV using the A/V connecting cable. Then, set the TV/VCR selector on the TV to VCR.

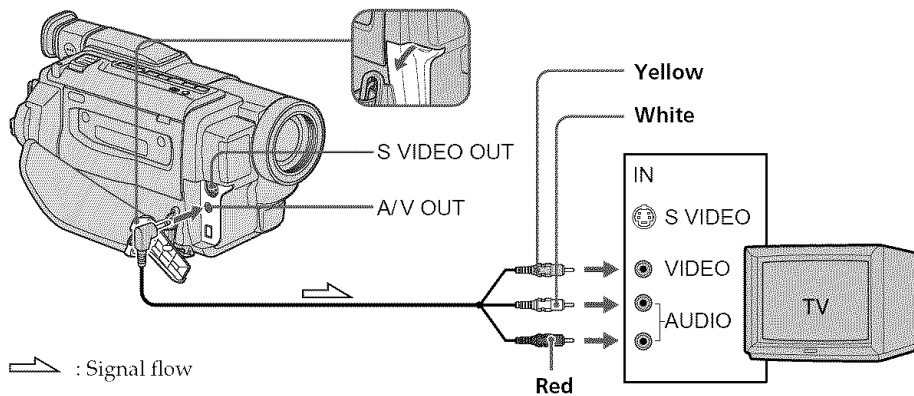

If your TV is already connected to a VCR

Connect your camcorder to the LINE IN input on the VCR by using the A/V connecting cable supplied with your camcorder. Set the input selector on the VCR to LINE.

If your TV is a monaural type

Connect the yellow plug of the A/V connecting cable to the video input jack and the white or the red plug to the audio input jack on the TV. If you connect the white plug, the sound is L (left) signal. If you connect the red plug, the sound is R (right) signal.

If your TV has an S video jack

Connect using an S video cable (optional) to obtain high-quality pictures.

With this connection, you do not need to connect the yellow (video) plug of the A/V connecting cable.

Connect an S video cable (optional) to the S video jacks on both your camcorder and the TV.

Viewing the recording on TV

Using the AV cordless IR receiver

Once you connect the AV cordless IR receiver (optional) to your TV or VCR, you can easily view the picture on your TV. For details, refer to the operating instructions of the AV cordless IR receiver.

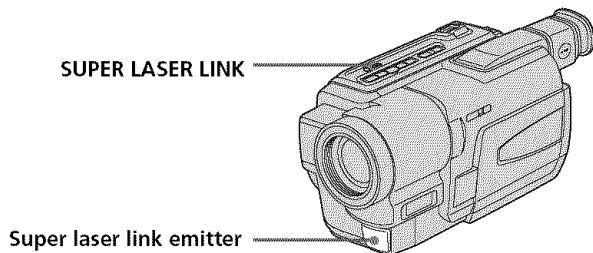

Before operation

Attach the power supply such as the AC power adaptor to your camcorder, and insert the recorded tape.

- (1) After connecting your TV and AV cordless IR receiver, set the POWER switch on the AV cordless IR receiver to ON.
- (2) Turn the TV on and set the TV/VCR selector on the TV to VCR.
- (3) Set the POWER switch on your camcorder to VCR.
- (4) Press SUPER LASER LINK. The lamp of SUPER LASER LINK lights up.
- (5) Press ► on your camcorder to start playback.
- (6) Point the super laser link emitter at the AV cordless IR receiver. Adjust the position of your camcorder and the AV cordless IR receiver to obtain clear playback pictures.

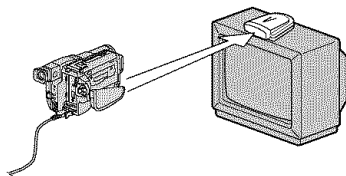

To cancel the super laser link function

Press SUPER LASER LINK. The lamp on the SUPER LASER LINK button goes out.

Viewing the recording on TV

If you use a Sony TV

- You can turn on the TV automatically when you press SUPER LASER LINK on your camcorder. To do so, do as follows in advance:
 - Turn the TV's main switch on.
 - Set AUTO TV ON to ON in the menu settings.
 - Point the super laser link emitter of your camcorder at the TV's remote sensor.
- You can switch the video input of the TV automatically to the one which the AV cordless IR receiver is connected. To do so, set AUTO TV ON to ON and TV INPUT to the same video input (1, 2, 3) in the menu settings. With some models, however, the picture and sound may be interrupted momentarily when the video input is switched.
- The above feature may not work on some TV models.

If you turn the power off

The super laser link function turns off automatically.

When the super laser link function is activated (the SUPER LASER LINK button is lit)

Your camcorder consumes power. Press SUPER LASER LINK to turn off the super laser link function when it is not needed.

 is a trademark of Sony Corporation.

Recording a still image on a tape

– Tape Photo recording

You can record a still image like a photograph. This mode is useful when you want to record an image such as a photograph or when you print a picture using a video printer (optional).

You can record about 510 images in the SP mode and about 765 images in the LP mode on a tape which can record for 60 minutes in the SP mode.

- (1) In the standby mode, keep pressing PHOTO lightly until a still image appears.

The CAPTURE indicator appears. Recording does not start yet.

To change the still image, release PHOTO, select a still image again, and then press and hold PHOTO lightly.

- (2) Press PHOTO deeper.

The still image on the screen is recorded for about seven seconds. The sound during those seven seconds is also recorded.

The still image is displayed on the screen until recording is completed.

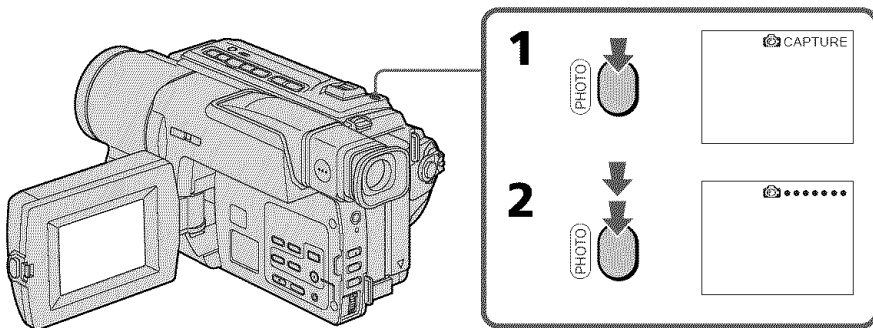

Notes

- During the tape photo recording, you cannot change the mode or setting.
- The PHOTO button does not work:
 - while the digital effect function is set or in use.
 - while the fader function is in use.
- When recording a still image, do not shake your camcorder. Mosaic-pattern noise may appear on the image.

To use the tape photo recording function using the Remote Commander

Press PHOTO on the Remote Commander. Your camcorder records an image on the screen immediately.

When you use the tape photo recording function during normal CAMERA recording

You cannot check an image on the screen by pressing PHOTO lightly. Press PHOTO deeper. The still image is then recorded for about 7 seconds, and your camcorder returns to the standby mode. During the 7 seconds to record, you cannot shoot another still image.

Recording a still image on a tape – Tape Photo recording

Printing the still image

You can print a still image by using the video printer (optional). Connect the video printer using the A/V connecting cable supplied with your camcorder. Connect the A/V connecting cable to the A/V OUT jack and connect the yellow plug of the cable to the video input of the video printer. Refer to the operating instructions of the video printer as well.

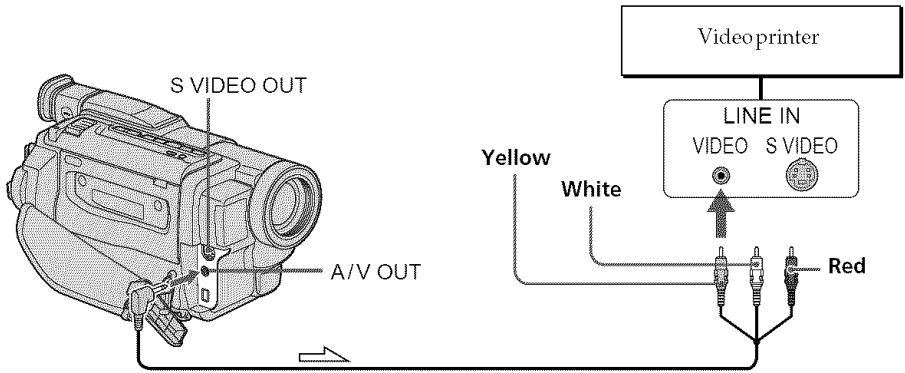



If the video printer is equipped with the S video input

Use the S video connecting cable (optional). Connect it to the S VIDEO OUT jack and the S video input of the video printer.

Using the wide mode

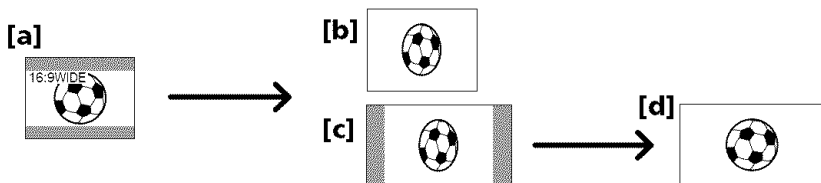
You can record a 16:9 wide picture to watch on the 16:9 wide-screen TV (16:9 WIDE). Black bands appear on the LCD screen during recording in 16:9 WIDE mode [a]. The pictures during playing back on a normal TV [b] or a wide-screen TV [c] are compressed in the widthwise direction. If you set the screen mode of the wide-screen TV to the full mode, you can watch pictures of normal images [d].



In CAMERA mode, set 16:9WIDE to ON in  in the menu settings (p. 80).

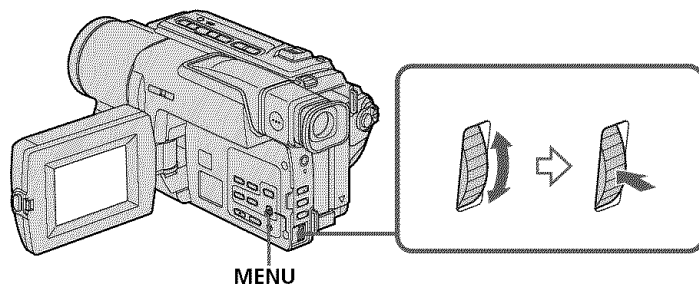

To cancel the wide mode

Set 16:9WIDE to OFF in the menu settings.

In the wide mode, you cannot select the following functions:

- Old movie
- Bounce

During recording

You cannot select or cancel the wide mode. When you cancel the wide mode, set your camcorder to the standby mode and then set 16:9WIDE to OFF in the menu settings.

Connection for a TV

Pictures recorded in the 16:9WIDE mode automatically appear on the TV screen at full size when:

- you connect your camcorder to a TV that is compatible with the video ID (ID-1/ID-2) system.
- you connect your camcorder to the S video jack on the TV.

ID-2 system

The ID-2 system sends a copyright protection signal with ID-1 signals inserted between video signals when you connect your camcorder to other equipment by an A/V connecting cable.

If the wide mode is set to ON

The SteadyShot function does not work. If you set 16:9WIDE to ON in the menu settings when the SteadyShot function is working,  flashes and the SteadyShot function does not function.

Using the fader function

You can fade the picture in or out to give your recording a professional appearance.

[a]

STBY

REC

FADER

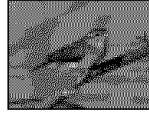

M.FADER
(mosaic)

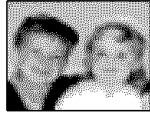

BOUNCE*

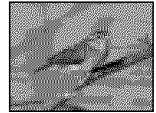
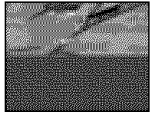

OVERLAP*



WIPE*

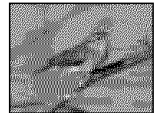
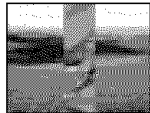
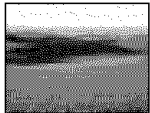

DOT*
(random dot)

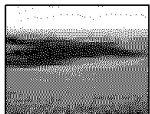

[b]

STBY

REC

MONOTONE

When fading in, the picture gradually changes from black-and-white to color.
When fading out, the picture gradually changes from color to black-and-white.

* Fade in only

Using the fader function

(1) When fading in [a]

In the standby mode, press FADER until the desired fader indicator flashes.

When fading out [b]

In the recording mode, press FADER until the desired fader indicator flashes.

The indicator changes as follows:

FADER → M.FADER → BOUNCE → MONOTONE

↑no indicator ← DOT ← WIPE ← OVERLAP ←

The last selected fader mode is indicated first of all.

(2) Press START/STOP. The fader indicator stops flashing.

After the fade in/out is carried out, your camcorder automatically returns to the normal mode.

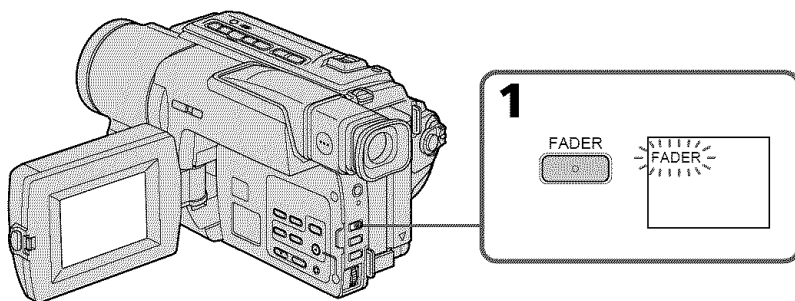

To cancel the fader function

Before pressing START/STOP, press FADER until the indicator disappears.

Using the fader function

Note

You cannot use the following functions while using the fader function. Also, you cannot use the fader function while using the following functions:

- Digital effect
- Low lux mode of PROGRAM AE (Overlap, wipe, or dot function only)
- SuperNightShot
- Tape photo recording

Before operating the overlap, wipe, or dot function

Your camcorder stores the image on the tape. As the image is being stored, the indicator flashes quickly, and the image you are shooting disappears from the screen. Depending on the tape condition, the image may not be recorded clearly.

While using the bounce function, you cannot use the following functions:

- Focus
- Zoom
- Picture effect

Note on the bounce function

The BOUNCE indicator does not appear in the following mode or functions:

- D ZOOM is activated in the menu settings
- Wide mode
- Picture effect
- PROGRAM AE

Using special effects – Picture effect

You can digitally process images to obtain special effects like those in films or on the TV.

NEG. ART [a] : The color and brightness of the image are reversed.

SEPIA : The image is sepia.

B&W : The image is monochrome (black-and-white).

SOLARIZE [b] : The light intensity is clearer, and the picture looks like an illustration.

SLIM [c] : The image expands vertically.

STRETCH [d] : The image expands horizontally.

PASTEL [e] : The contrast of the image is emphasized, and the image looks like an animated cartoon.

MOSAIC [f] : The image is mosaic.



(1) In CAMERA mode, select P EFFECT in  in the menu settings. (p. 80).

(2) Select the desired picture effect mode in the menu settings, then press the SEL/PUSH EXEC dial.

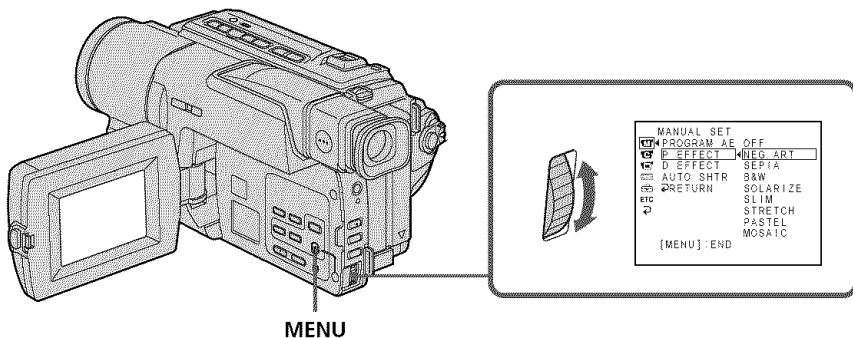

To cancel the picture effect function

Set P EFFECT to OFF in the menu settings.

While using the picture effect function

You cannot select OLD MOVIE with the digital effect function.

When you turn the power off

The picture effect is automatically canceled.

Using special effects – Digital effect

You can add special effects to recorded images using the various digital functions. The sound is recorded normally.

STILL

You can record a still image so that it is superimposed on a moving image.

FLASH (FLASH MOTION)

You can record still images successively at constant intervals.

LUMI. (LUMINANCEKEY)

You can swap a brighter area in a still image with a moving image.

TRAIL

You can record the image so that an incidental image like a trail is left.

SLOW SHTR (SLOW SHUTTER)

You can slow down the shutter speed. The slow shutter mode is good for recording dark images more brightly.

OLD MOVIE

You can add an old movie type atmosphere to images. Your camcorder automatically sets the wide mode to ON, picture effect to SEPIA, and the appropriate shutter speed.

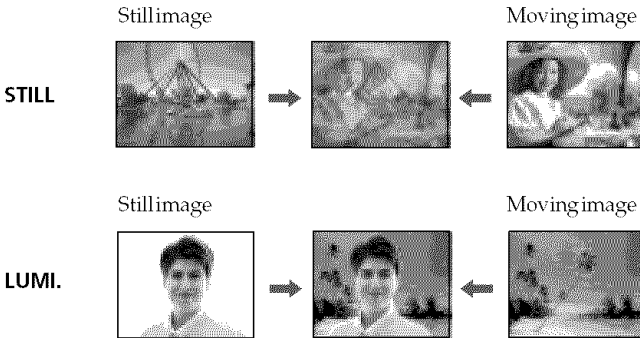

Using special effects – Digital effect

- (1) In CAMERA mode, select D EFFECT in  in the menu settings (p. 80).
- (2) Select the desired digital effect mode in the menu settings, then press the SEL/PUSH EXEC dial. The indicator lights up and the bars appear. In the STILL and LUMI. modes, the still image is stored in memory.
- (3) Turn the SEL/PUSH EXEC dial to adjust the effect as follows:

STILL – The rate of the still image you want to superimpose on the moving image

FLASH – The interval of flash motion

LUMI. – The color scheme of the area in the still image which is to be swapped with a moving image

TRAIL – The vanishing time of the incidental image

SLOW SHTR – Shutter speed. The larger the shutter speed number, the slower the shutter speed.

OLD MOVIE – No adjustment necessary

The more bars there are on the screen, the stronger the digital effect. The bars appear in the following modes: STILL, FLASH, LUMI. and TRAIL.

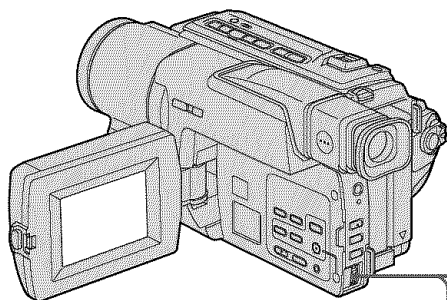

1



```
MANUAL SET
D EFFECT
OFF
STILL
FLASH
LUMI.
TRAIL
SLOW SHTR
OLD MOVIE
[MENU] : END
```

2



```
MANUAL SET
D EFFECT
OFF
STILL
FLASH
LUMI.
TRAIL
SLOW SHTR
OLD MOVIE
[MENU] : END
```



```
MANUAL SET
D EFFECT
OFF
STILL
FLASH
LUMI.
TRAIL
SLOW SHTR
OLD MOVIE
[MENU] : END
```

3



```
MANUAL SET
PROGRAM AE
P EFFECT
D EFFECT LUMI.
AUTO SHTR
RETURN
[MENU] : END
```

To cancel the digital effect function

Set D EFFECT to OFF in the menu settings.

Notes

- The following functions do not work during digital effect:
 - Fader
 - Low lux mode of PROGRAM AE
 - Tape photo recording
 - SuperNightShot
- The PROGRAM AE function does not work in the slow shutter mode.
- The following functions do not work in the old movie mode:
 - Widemode
 - Pictureeffect
 - PROGRAM AE

When you turn the power off

The digital effect is automatically canceled.

When recording in the slow shutter mode

Auto focus may not be effective. Focus manually using a tripod.

Shutter speed

Shutter speed number	Shutter speed
SLOW SHTR 1	1/30
SLOW SHTR 2	1/15
SLOW SHTR 3	1/8
SLOW SHTR 4	1/4

Using the PROGRAM AE function

You can select PROGRAM AE (Auto Exposure) mode to suit your specific shooting requirements.

Spotlight

This mode prevents people's faces, for example, from appearing excessively white when shooting subjects lit by strong light in the theater.

Soft portrait

This mode brings out the subject while creating a soft background for subjects such as people or flowers.

Sports lesson

This mode minimizes shake on fast-moving subjects such as in tennis or golf.

Beach & ski

This mode prevents people's faces from appearing dark in strong light or reflected light, such as at a beach in midsummer or on a ski slope.

Sunset & moon

This mode allows you to maintain atmosphere when you are recording sunsets, general night views, fireworks displays and neon signs.

Landscape

This mode is for when you are recording distant subjects such as mountains and prevents your camcorder from focusing on glass or metal mesh in windows when you are recording a subject behind glass or a screen.

Low lux

This mode makes subjects brighter in insufficient light.

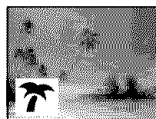

Using the PROGRAM AE function

- (1) In CAMERA mode, select PROGRAM AE in  in the menu settings (p. 80).
- (2) Select the desired PROGRAM AE mode in the menu settings, then press the SEL/PUSH EXEC dial.

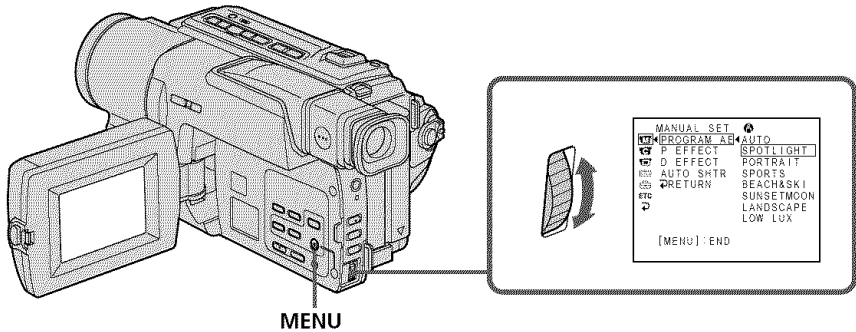

To cancel the PROGRAM AE function

Set PROGRAM AE to AUTO in the menu settings.

Notes

- In the spotlight, sports lesson and beach & ski modes, you cannot take close-ups. This is because your camcorder is set to focus only on subjects in the middle to far distance.
- In the sunset & moon and landscape modes, your camcorder is set to focus only on distant subjects.
- The following functions do not work in the PROGRAM AE mode:
 - Slow shutter
 - Old movie
 - Bounce
- The following functions do not work in the low lux mode:
 - Digital effect
 - Overlap
 - Wipe
 - Dot
- While setting NIGHTSHOT to ON, the PROGRAM AE function does not work. (The indicator flashes.)

Even if the PROGRAM AE function is selected

You can adjust the exposure manually.

If you are recording under a discharge tube such as a fluorescent lamp, sodium lamp or mercury lamp

Flickering or changes in color may occur in the following modes. If this happens, turn the PROGRAM AE function off.

- Soft portrait mode
- Sports lesson mode

Adjusting the exposure manually

You can manually adjust and set the exposure.

Adjust the exposure manually in the following cases:

- The subject is backlit
- Bright subject and dark background
- To record dark pictures (e.g. night scenes) faithfully

(1) In CAMERA mode, press EXPOSURE.

The exposure indicator appears on the screen.

(2) Turn the SEL/PUSH EXEC dial to adjust the brightness.

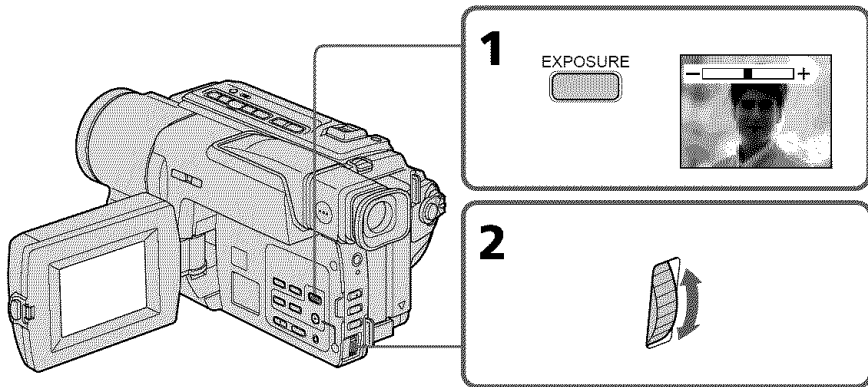

To return to the automatic exposure mode

Press EXPOSURE.

Note

When you adjust the exposure manually, the backlight function does not work in CAMERA mode.

Your camcorder automatically returns to the automatic exposure mode:

- if you change the PROGRAM AE mode
- if you slide NIGHTSHOT to ON

Focusing manually

You can gain better results by manually adjusting the focus in the following cases:

- The autofocus mode is not effective when shooting:
 - subjects through glass coated with water droplets.
 - horizontal stripes.
 - subjects with little contrast with backgrounds such as walls and sky.
- When you want to change the focus from a subject in the foreground to a subject in the background.
- Shooting a stationary subject when using a tripod.

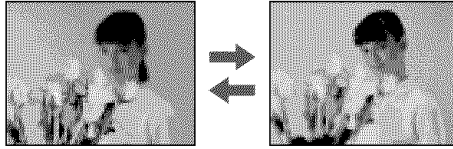

- (1) In CAMERA mode, press FOCUS. The  indicator appears on the screen.
- (2) Turn the SEL/PUSH EXEC dial to sharpen focus.

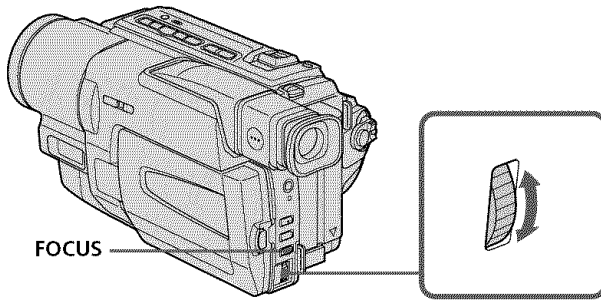

To return to the autofocus mode

Press FOCUS.



To focus precisely

Adjust the zoom by first focusing at the “T” (telephoto) position and then shooting at the “W” (wide-angle) position. This makes focusing easier.

When you shoot close to the subject

Focus at the end of the “W” (wide-angle) position.

 changes to the following indicators:

-  when recording a distant subject.
-  when the subject is too close to focus on.

Superimposing a title

You can select one of eight preset titles and two custom titles (p. 50). You can also select the language, color, size and position of titles.



- (1) In CAMERA mode, press TITLE to display the title menu.
- (2) Turn the SEL/PUSH EXEC dial to select , then press the dial.
- (3) Select the desired title in the menu settings, then press the SEL/PUSH EXEC dial. The titles are displayed in the language you selected.
- (4) Change the color, size, or position, if necessary.
 - ① Turn the SEL/PUSH EXEC dial to select the color, size, or position, then press the dial. The item appears.
 - ② Turn the SEL/PUSH EXEC dial to select the desired item, then press the dial.
 - ③ Repeat steps ① and ② until the title is laid out as desired.
- (5) Press the SEL/PUSH EXEC dial again to complete the setting.
- (6) Press START/STOP to start recording.
- (7) When you want to stop recording the title, press TITLE.

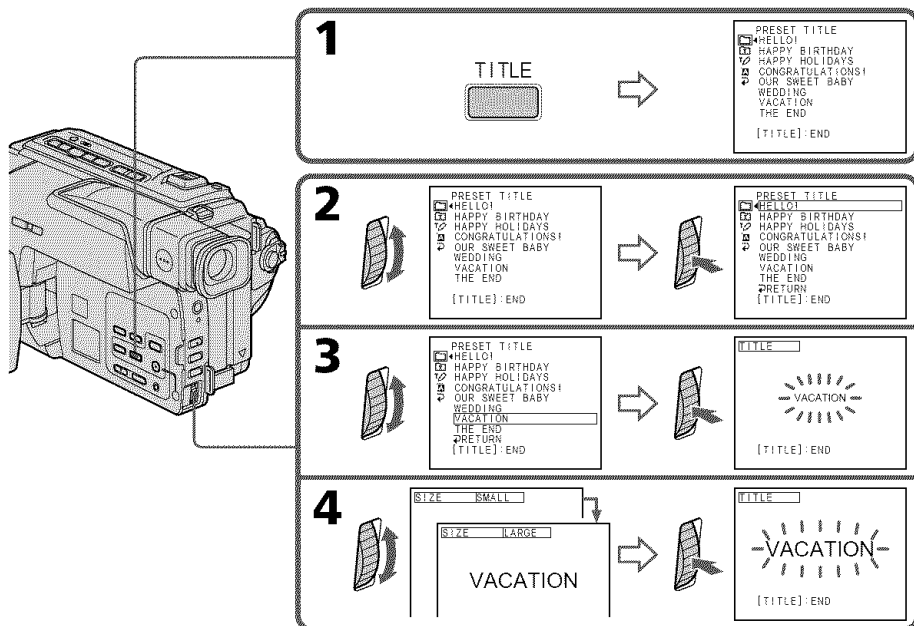

Superimposing a title

To superimpose the title while you are recording

Press TITLE while you are recording, and carry out steps 2 to 5. When you press the SEL/PUSH EXEC dial at step 5, the title is recorded.

To select the language of a preset title

If you want to change the language, select [A] before step 2. Then select the desired language and return to step 2.

If you display the menu while superimposing a title

The title is not recorded while the menu is displayed.

To use the custom title

If you want to use the custom title, select [C] in step 2.

Title setting

- The title color changes as follows :
WHITE ↔ YELLOW ↔ VIOLET ↔ RED ↔ CYAN ↔ GREEN ↔ BLUE
- The title size changes as follows :
SMALL ↔ LARGE
You cannot input 13 characters or more in LARGE size.
- The title position changes as follows :
1 ↔ 2 ↔ 3 ↔ 4 ↔ 5 ↔ 6 ↔ 7 ↔ 8 ↔ 9
The larger the position number, the lower the title is positioned.
When you select the title size LARGE, you cannot choose position 9.

When you are selecting and setting the title

You cannot record the title displayed on the screen.

When you superimpose a title while you are recording

The beep does not sound.

While you are playing back

You can superimpose a title. However, the title is not recorded on tape.

You can record a title when you dub a tape connecting your camcorder to the VCR with the A/V connecting cable. If you use the i.LINK cable instead of the A/V connecting cable, you cannot record the title.

Making your own titles

You can make up to two titles and store them in your camcorder. Each title can have up to 20 characters.

- (1) In CAMERA or VCR mode, press TITLE.
- (2) Turn the SEL/PUSH EXEC dial to select , then press the dial.
- (3) Turn the SEL/PUSH EXEC dial to select the first line (CUSTOM1 SET) or second line (CUSTOM2 SET), then press the dial.
- (4) Turn the SEL/PUSH EXEC dial to select the column of the desired character, then press the dial.
- (5) Turn the SEL/PUSH EXEC dial to select the desired character, then press the dial.
- (6) Repeat steps 4 and 5 until you have selected all characters and completed the title.
- (7) To finish making your own titles, turn the SEL/PUSH EXEC dial to select [SET], then press the dial. The title is stored in memory.
- (8) Press TITLE to make the title menu disappear.

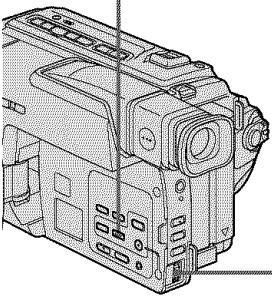

1

TITLE

PRESET TITLE

HELLO

HAPPY BIRTHDAY

HAPPY HOLIDAYS

CONGRATULATIONS

OUR SWEET BABY

WEDDING

VACATION

THE END

[TITLE]:END

2

TITLE SET

CUSTOM1 SET

CUSTOM2 SET

[CUSTOM1 SET]

[TITLE]:END

TITLE SET

CUSTOM1 SET

CUSTOM2 SET

[RETURN]

[TITLE]:END

3

TITLE SET

CUSTOM1 SET

CUSTOM2 SET

[RETURN]

[TITLE]:END

TITLE SET P1

ABCDE 12345 67890

FGHIJ 67890 12345

KLMNO AEIOU []

PQRST AEIOU []

UVWXY AEIJS [SET]

Z& ?1 A096

/ - AIOUA

[TITLE]:END

4

TITLE SET P1

ABCDE 12345 67890

FGHIJ 67890 12345

KLMNO AEIOU []

PQRST AEIOU []

UVWXY AEIJS [SET]

Z& ?1 A096

/ - AIOUA

[TITLE]:END

TITLE SET P1

ABCDE 12345 67890

FGHIJ 67890 12345

KLMNO AEIOU []

PQRST AEIOU []

UVWXY AEIJS [SET]

Z& ?1 A096

/ - AIOUA

[TITLE]:END

6

TITLE SET P1

ABCDE 12345 67890

FGHIJ 67890 12345

KLMNO AEIOU []

PQRST AEIOU []

UVWXY AEIJS [SET]

Z& ?1 A096

/ - AIOUA

[TITLE]:END

TITLE SET P1

ABCDE 12345 67890

FGHIJ 67890 12345

KLMNO AEIOU []

PQRST AEIOU []

UVWXY AEIJS [SET]

Z& ?1 A096

/ - AIOUA

[TITLE]:END

To change a title you have stored

In step 3, select CUSTOM1 SET or CUSTOM2 SET, depending on which title you want to change, then press the SEL/PUSH EXEC dial. Turn the SEL/PUSH EXEC dial to select [←], then press the dial to delete the title. The last character is erased. Enter the new title as desired.

If you take 3 minutes or longer to enter characters in the standby mode while a cassette is in your camcorder

The power automatically turns off. The characters you have entered remain stored in memory. Set the POWER switch to OFF (CHARGE) once, and turn it to CAMERA again, then proceed from step 1.

We recommend setting the POWER switch to VCR or removing the cassette so that your camcorder does not automatically turn off while you are entering title characters.

If you select [→P2]

The menu for selecting alphabet and Russian characters appears. Select [→P1] to return to the previous screen.

To erase a character

Select [←]. The last character is erased.

To enter a space

Select [Z & ?!], then select the blank part.

Using the built-in light

You can use the built-in light to suit your shooting situation. The recommended distance between the subject and camcorder is about 1.5 m (5 feet).

Press LIGHT until the  indicator appears on the screen while your camcorder is in CAMERA mode. The built-in light turns on.

If you turn the POWER switch to OFF (CHARGE), the built-in light turns off simultaneously. You cannot turn the built-in light on by turning the POWER switch to CAMERA again. To turn on the built-in light again, press LIGHT again in CAMERA mode.

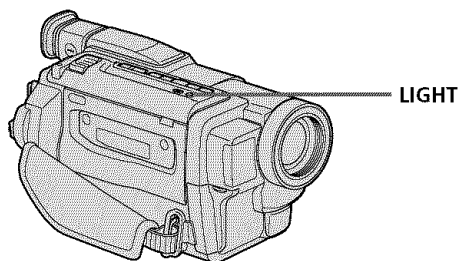

To turn off the built-in light

Press LIGHT until no indicator appears on the screen.

To turn on the built-in light automatically

Press LIGHT until the  indicator appears on the screen.

The built-in light automatically turns on and off according to the ambient brightness.

CAUTION

Be careful not to touch the lighting section, because the plastic window and surrounding surfaces are hot while the light is on. It remains hot for a while after the light is turned off.

DANGER

Not to be handled by children.

Emits intense heat and light.

Use with caution to reduce the risk of fire or injury to persons.

Do not directly light at persons or materials from less than 1.22 m (4 feet) during use and until cool.

Turn the built-in light off when not in use.

When you press LIGHT

The indicator changes as follows:

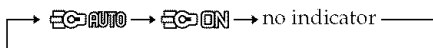

Using the built-in light

Notes

- The built-in light turns off automatically in the following cases:
 - When it stays on in the AUTO mode for more than 5 minutes
 - When you leave it on for more than 5 minutes with no cassette inserted or after the tape has run out.To turn the built-in light on again. Press LIGHT again.
- The battery pack is quickly discharging while the built-in light is turned on. Turn it off when not in use.
- When you do not use your camcorder, turn the built-in light off and remove the battery pack to avoid turning on the built-in light accidentally.
- When flickering occurs while shooting in the AUTO mode, press LIGHT until the **ECO** indicator appears.
- The built-in light may turn on/off when you use the PROGRAM AE or backlight function while shooting in the AUTO mode.
- The built-in light may be turned off when inserting or ejecting a cassette.
- While the end search function is working, the built-in light is turned off.
- When you use the conversion lens (optional), light from the built-in light is blocked and may not illuminate the subject properly.

Replacing the bulb

Use the Sony XB-3D halogen lamp (optional). The supplied halogen lamp is not on the market. Purchase the Sony XB-3D halogen lamp. Remove the power source before replacing the bulb.

- (1) Remove the built-in light unit while pushing the hole under the built-in light unit using a wire.
- (2) Turn the bulb housing counterclockwise and detach from the built-in light unit.
- (3) Replace the bulb using a dry cloth.
- (4) Attach the bulb housing turning it clockwise, then replace the built-in light unit.

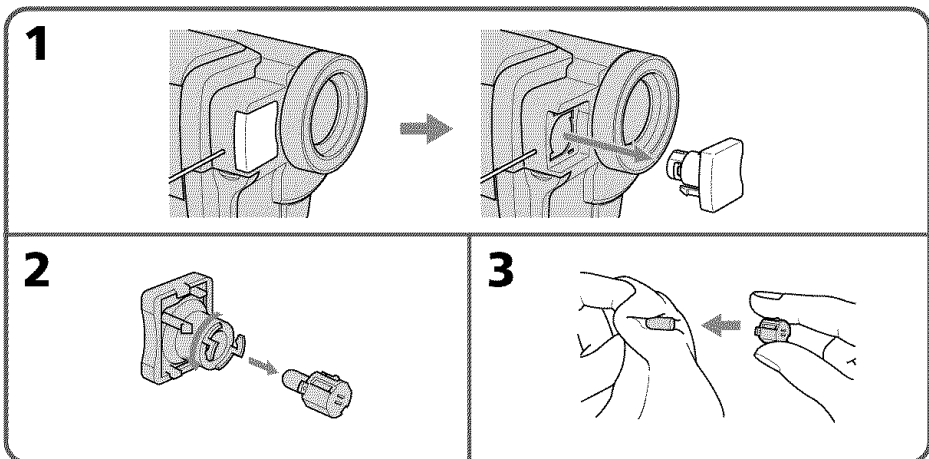

Using the built-in light

CAUTION

- When replacing the bulb, use only the Sony XB-3D halogen lamp (optional) to reduce the risk of fire.
- To prevent possible burn hazard, disconnect the power source before replacing and do not touch the bulb until the bulb becomes cool enough to handle (for about 30 minutes or more).

Note

To prevent the bulb from being smudged with finger prints, handle it with a dry cloth, etc. If the bulb is smudged, wipe it completely.

Playing back a tape with picture effects

During playback, you can process a scene using the picture effect functions: NEG. ART, SEPIA, B&W and SOLARIZE.

- (1) In the playback or playback pause mode, select P EFFECT in  in the menu settings (p. 80).
- (2) Select the desired mode by turning the SEL/PUSH EXEC dial.
For details of each picture effect function, see page 40.

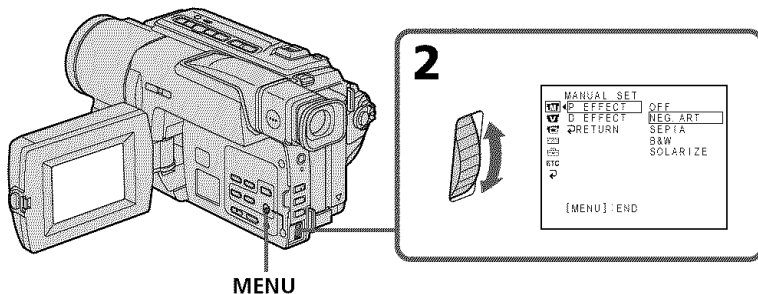

To cancel the picture effect function

Set P EFFECT to OFF in the menu settings.

Notes

- You cannot process externally input scenes using the picture effect function.
- You cannot record pictures that you have processed using the picture effect function with this camcorder. To record pictures that you have processed using the picture effect function, record the pictures on the VCR using your camcorder as a player.

Pictures processed by the picture effect function

Pictures processed by the picture effect function are not output through the  DVIN/OUT jack.

When you set the POWER switch to OFF (CHARGE) or stop playing back

The picture effect function is automatically canceled.

Playing back a tape with digital effects

During playback, you can process a scene using the digital effect functions: STILL, FLASH, LUMI. and TRAIL.

- (1) In the playback or playback pause mode, select D EFFECT in  in the menu settings (p. 80).
- (2) Select the desired digital effect mode (STILL, FLASH, LUMI. or TRAIL) in the menu settings, then press the SEL/PUSH EXEC dial.
The digital effect indicator lights up and the bars appear. In the STILL or LUMI. mode, the image where you press the SEL/PUSH EXEC dial is stored in memory as a still image.
- (3) Turn the SEL/PUSH EXEC dial to adjust the effect.
For details of each digital effect function, see page 41.

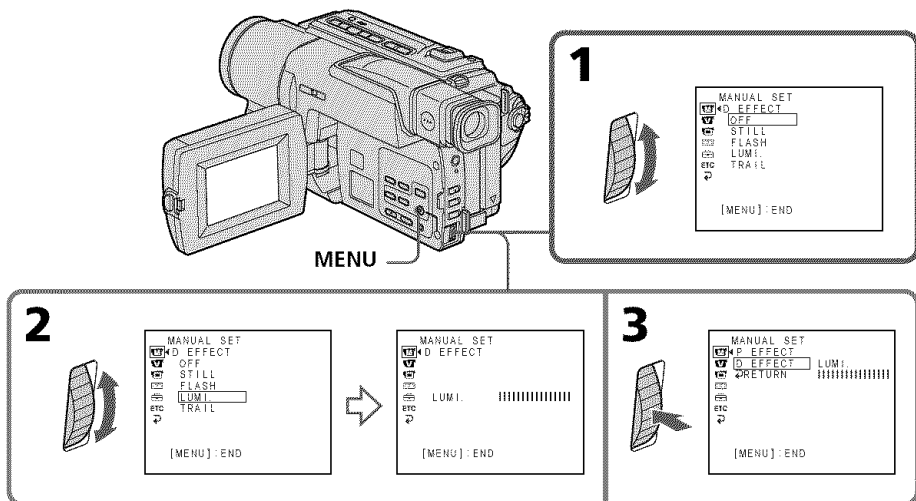

To cancel the digital effect function

Set D EFFECT to OFF in the menu settings.

Notes

- You cannot process externally input scenes using the digital effect function.
- You cannot record images that you have processed using the digital effect function with this camcorder. To record images that you have processed using the digital effect function, record the images on the VCR using your camcorder as a player.

Pictures processed by the digital effect function

Pictures processed by the digital effect function are not output through the OUT jack.

 DVIN/

When you set the POWER switch to OFF (CHARGE) or stop playing back

The digital effect function is automatically canceled.

Enlarging images recorded on tapes

- Tape PB ZOOM

You can enlarge moving and still images recorded on tapes.

- (1) Press PB ZOOM on your camcorder while you are playing back. The image is enlarged, and \updownarrow appears on the screen.
- (2) Turn the SEL/PUSH EXEC dial to move the enlarged image, then press the dial.
 - \up : The image moves downwards.
 - \down : The image moves upwards.
 - $\leftarrow \rightarrow$ becomes available.
- (3) Turn the SEL/PUSH EXEC dial to move the enlarged image, then press the dial.
 - \leftarrow : The image moves rightward (Turn the dial downwards.)
 - \rightarrow : The image moves leftward (Turn the dial upwards.)

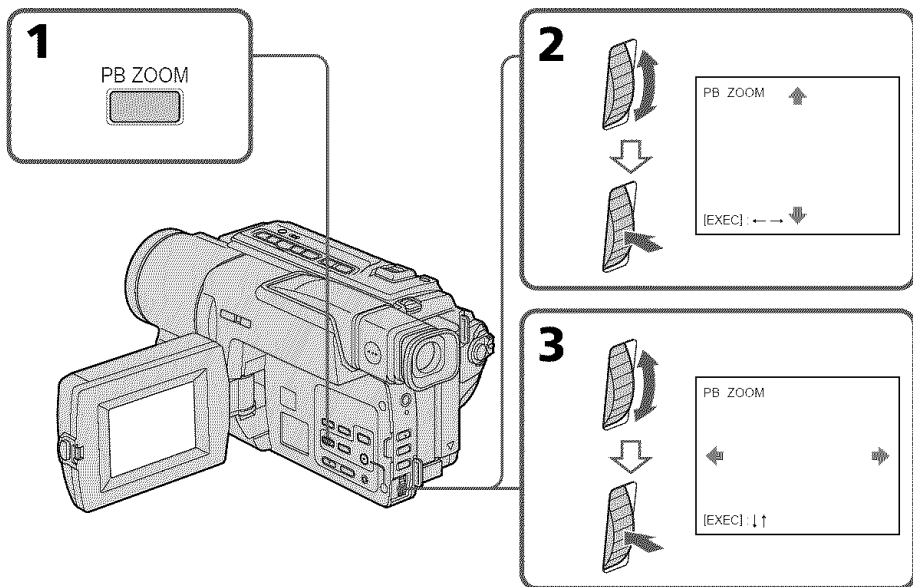

To cancel Tape PB ZOOM function

Press PB ZOOM.

Notes

- You cannot process externally input scenes using Tape PB ZOOM function.
- You cannot record pictures that you have processed using Tape PB ZOOM function with this camcorder. To record pictures that you have processed using Tape PB ZOOM function, record the pictures on the VCR using your camcorder as a player.

Pictures processed by Tape PB ZOOM function

Pictures processed by Tape PB ZOOM function are not output through the \mathbb{I} DV IN/OUT jack.

When you set the POWER switch to OFF (CHARGE) or stop playing back Tape PB ZOOM function is automatically canceled.

Quickly locating a scene using the zero set memory function

Your camcorder goes forward or backward to automatically stop at a desired scene having a counter value of "0:00:00".

Use the Remote Commander for this operation.

Use this function, for example, to view a desired scene later on during playback.

- (1) In the playback mode, press DISPLAY.
- (2) Press ZERO SET MEMORY at the point you want to locate later. The counter shows "0:00:00" and the ZERO SET MEMORY indicator flashes.
- (3) Press ■ when you want to stop playback.
- (4) Press ◀◀ to rewind the tape to the counter's zero point. The tape stops automatically when the counter reaches approximately zero. The ZERO SET MEMORY indicator disappears and the time code appears.
- (5) Press ▶▶. Playback starts from the counter's zero point.

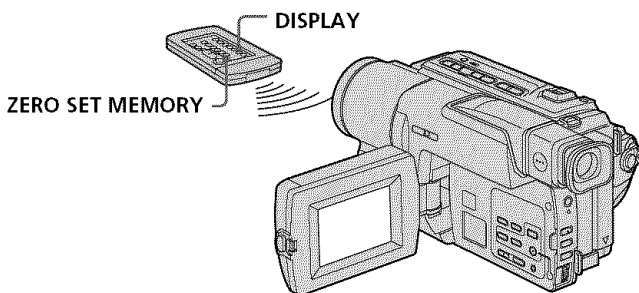

Notes

- When you press ZERO SET MEMORY before rewinding the tape, the zero set memory function is canceled.
- There may be a discrepancy of several seconds from the time code.

If a tape has a blank portion in the recorded portions

The zero set memory function may not work correctly.

The zero set memory function also in the standby mode

When you insert a scene in the middle of a recorded tape, press ZERO SET MEMORY at the point you want to end the insertion. Rewind the tape to the insert point, and start recording. Recording stops automatically at the tape counter zero point. Your camcorder returns to the standby mode.

Searching a recording by date

- Date search

You can automatically search for the point where the recording date changes and start playback from that point (**Date search**). Use the Remote Commander for this operation. Use this function to check where recording dates change or to edit the tape at each recording date.

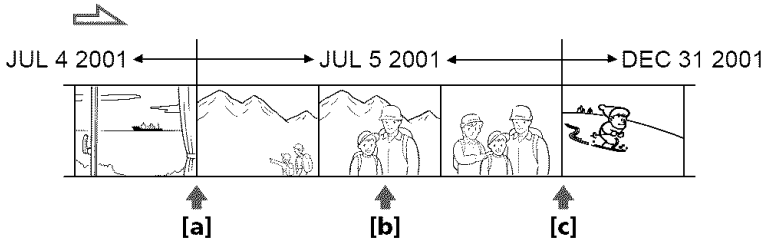

- (1) Set the POWER switch to VCR.
- (2) Press SEARCH MODE on the Remote Commander repeatedly, until the date search indicator appears.

The indicator changes as follows:

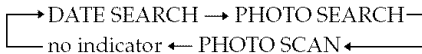

- (3) When the current position is [b], press ◀◀ to search towards [a] or press ▶▶ to search towards [c]. Your camcorder automatically starts playback at the point where the date changes. Each time you press ◀◀ or ▶▶, the camcorder searches for the previous or next date.

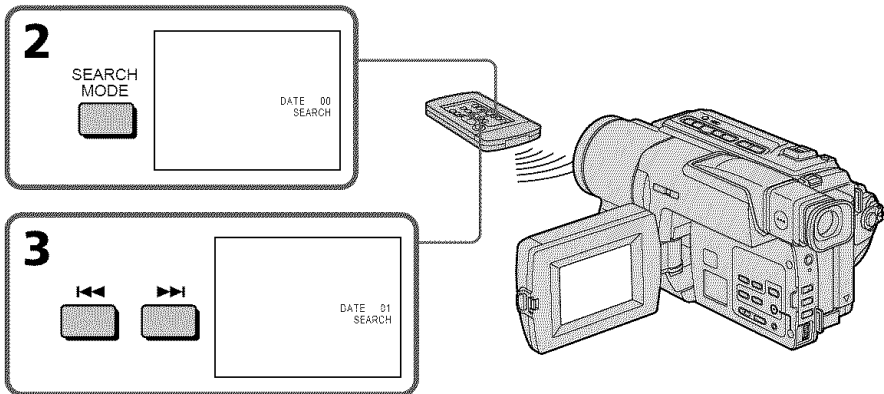

To stop searching

Press ■.

Searching a recording by date – Date search

Note

If one day's recording is less than 2 minutes, your camcorder may not accurately find the point where the recording date changes.

If a tape has a blank portion in the recorded portions

The date search function may not work correctly.

Searching for a photo

- Photo search/Photo scan

You can search for the still image recorded on tape (**photo search**).

You can also search for still images one after another and display each image for 5 seconds automatically (**photo scan**). Use the Remote Commander for these operations.

Searching for a photo

- (1) Set the POWER switch to VCR.
- (2) Press SEARCH MODE on the Remote Commander repeatedly, until the photo search indicator appears.

The indicator changes as follows:

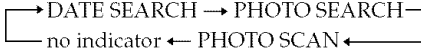

- (3) Press ◀◀ or ▶▶ to select the photo for playback. Each time you press ◀◀ or ▶▶, the camcorder searches for the previous or next photo. Your camcorder automatically starts playback from the photo.

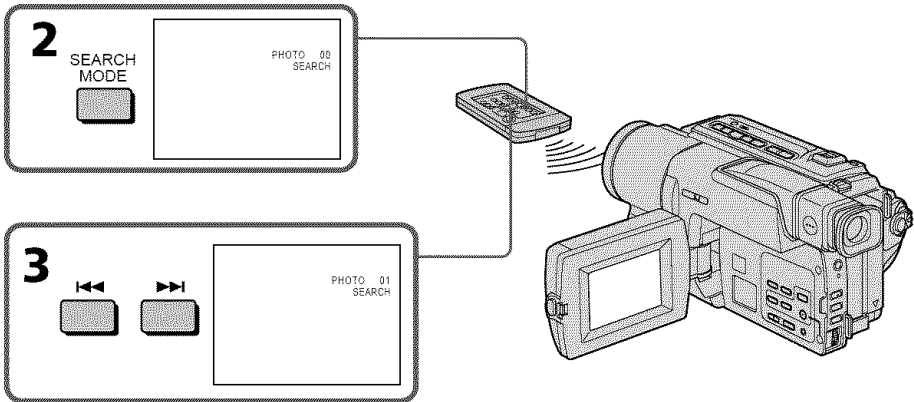

To stop searching

Press ■.

Searching for a photo – Photo search/Photo scan

Scanning photo

- (1) Set the POWER switch to VCR.
- (2) Press SEARCH MODE on the Remote Commander repeatedly, until the photo scan indicator appears.

The indicator changes as follows:

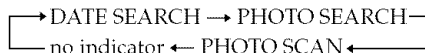

- (3) Press ◀◀ or ▶▶.
- Each photo is played back for about 5 seconds automatically.

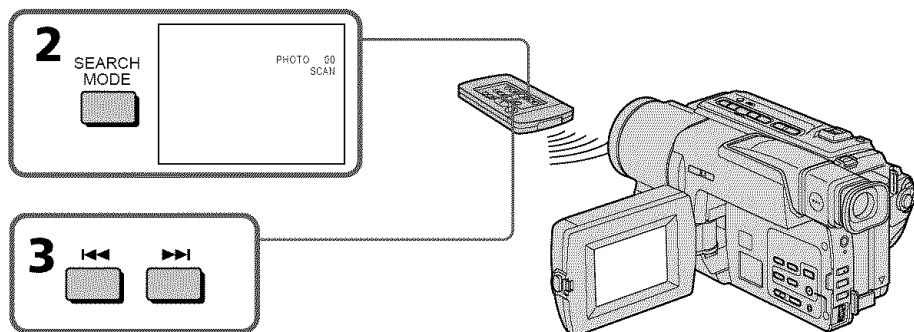

To stop scanning

Press ■.

If a tape has a blank portion in the recorded portions

The photo search and photo scan functions may not work correctly.

Dubbing a tape

Using the A/V connecting cable

Connect your camcorder to the VCR using the A/V connecting cable supplied with your camcorder.

You can record and edit a picture with the connected VCR by using your camcorder as a player.

Set DISPLAY to LCD in **[ETC]** in the menu settings. (The default setting is set to LCD.)

Make the indicators disappear by pressing DISPLAY, DATA CODE or SEARCH MODE on the Remote Commander. If you do not make the indicators disappear, they are recorded on tapes.

- (1) Insert a blank tape (or a tape you want to record over) into the VCR, and insert the recorded tape into your camcorder.
- (2) Set the input selector on the VCR to LINE. Refer to the operating instructions of your VCR for more information.
- (3) Set the POWER switch to VCR.
- (4) Play back the recorded tape on your camcorder.
- (5) Start recording on the VCR.

Refer to the operating instructions of your VCR for more information.

Editing

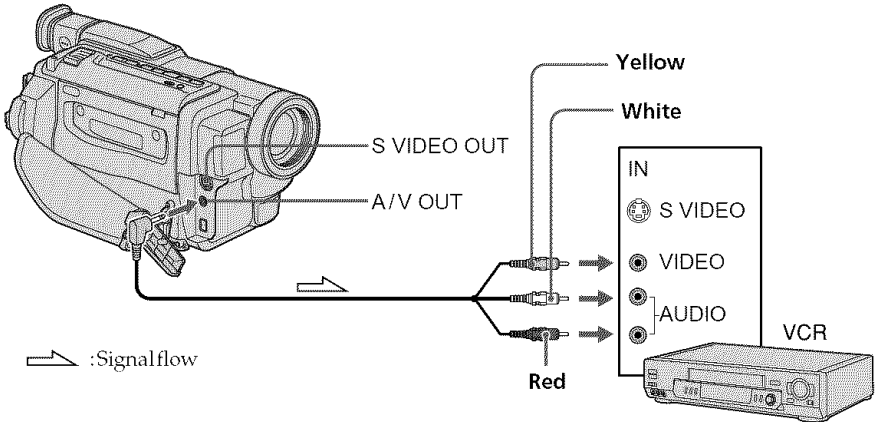

When you have finished dubbing a tape

Press **[]** on both your camcorder and the VCR.

You can edit on VCRs that support the following systems:

[] 8 mm, **[]** Hi8, **[]** Hi8, **[]** VHS VHS, **[]** S-VHS, **[]** S-VHS, **[]** VHSC, **[]** S-VHSC, **[]** Betamax, **[]** ED Betamax, **[]** mini DV, **[]** DV or **[]** Digital8

If your VCR is a monaural type

Connect the yellow plug of the A/V connecting cable to the video input jack and the white or the red plug to the audio input jack on the VCR. When the white plug is connected, the left channel audio is output, and when the red plug is connected, the right channel audio is output.

If your VCR has an S video jack

Connect using an S video cable (optional) to obtain high-quality pictures.

With this connection, you do not need to connect the yellow (video) plug of the A/V connecting cable.

Connect an S video cable (optional) to the S video jacks of both your camcorder and the VCR.

Dubbing a tape

Using the i.LINK cable (DV connecting cable)

Simply connect the i.LINK cable (DV connecting cable) (optional) to **i** DV IN/OUT and to DV IN/OUT of the DV products. With digital-to-digital connection, video and audio signals are transmitted in digital form for high-quality editing. You cannot dub the screen indicators.

- (1) Insert a blank tape (or a tape you want to record over) into the VCR, and insert the recorded tape into your camcorder.
- (2) Set the input selector on the VCR to DV IN if it is available. Refer to the operating instructions of your VCR for more information.
- (3) Set the POWER switch to VCR.
- (4) Play back the recorded tape on your camcorder.
- (5) Start recording on the VCR.

Refer to the operating instructions of your VCR for more information.

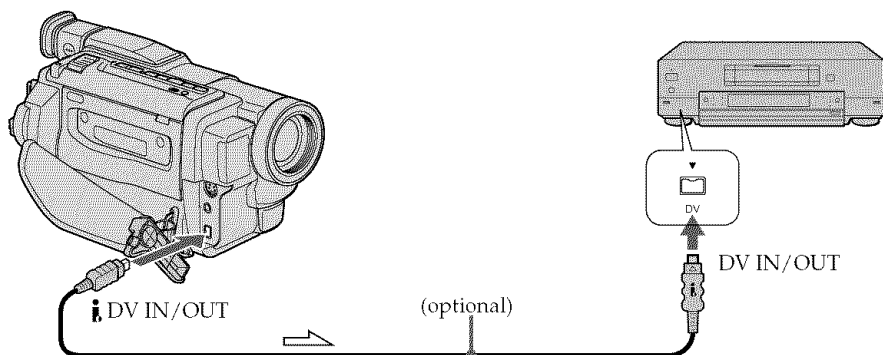

➡ : Signal flow

When you have finished dubbing a tape

Press **■** on both your camcorder and the VCR.

You can connect one VCR only using the i.LINK cable (DV connecting cable).

See page 94 for more information about i.LINK.

The following functions do not work during digital editing :

- Picture effect
- Digital effect
- Tape PB ZOOM

If you record a playback pause picture via the **i DV IN/OUT jack**

The recorded picture becomes rough. Also, when you play back the recorded pictures on other video equipment, the picture may jitter.

Dubbing only desired scenes – Digital program editing

You can duplicate selected scenes (programs) for editing onto a tape without operating the VCR.

Scenes can be selected by frame. You can set up to 20 programs.

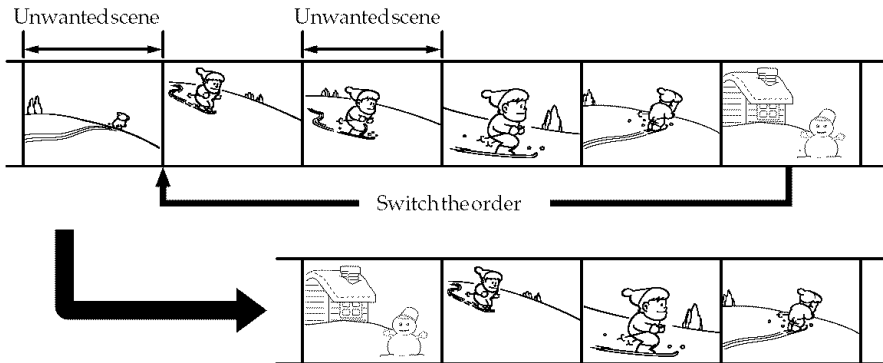

Before operating the Digital program editing function

Step 1 Connecting the VCR (p. 65).

Step 2 Setting the VCR for operation (p. 66 to 70).

Step 3 Adjusting the synchronicity of the VCR (p. 71).

When you dub using the same VCR again, you can skip steps 2 and 3.

Using the Digital program editing function

Operation 1 Making the program (p. 73).

Operation 2 Performing Digital program editing (dubbing a tape) (p. 74).

Step 1: Connecting the VCR

You can connect both an A/V connecting cable and an i.LINK cable (DV connecting cable).

When you use the A/V connecting cable, connect the devices as illustrated in page 63.

When you use an i.LINK cable (DV connecting cable), connect the devices as illustrated in page 64.

Dubbing only desired scenes – Digital program editing

Step 2: Setting the VCR to operate with the A/V connecting cable

To edit using the VCR, send the control signal by infrared ray to the remote sensor on the VCR.

When you connect using an A/V connecting cable, follow the procedure below, steps (1)~(4), to send the control signal correctly.

(1) Set the IR SETUP code

- ① Set the POWER switch to VCR on your camcorder.
- ② Turn the power of the connected VCR on, then set the input selector to LINE. When you connect a video camera recorder, set its power switch to VCR/VTR.
- ③ Press MENU to display the menu.
- ④ Turn the SEL/PUSH EXEC dial to select **ETC**, then press the dial.
- ⑤ Turn the SEL/PUSH EXEC dial to select EDIT SET, then press the dial.
- ⑥ Turn the SEL/PUSH EXEC dial to select CONTROL, then press the dial.
- ⑦ Turn the SEL/PUSH EXEC dial to select IR, then press the dial.
- ⑧ Turn the SEL/PUSH EXEC dial to select IR SETUP, then press the dial.
- ⑨ Turn the SEL/PUSH EXEC dial to select the IR SETUP code of your VCR, then press the dial.

Check the code in "About the IR SETUP code." (p. 67)

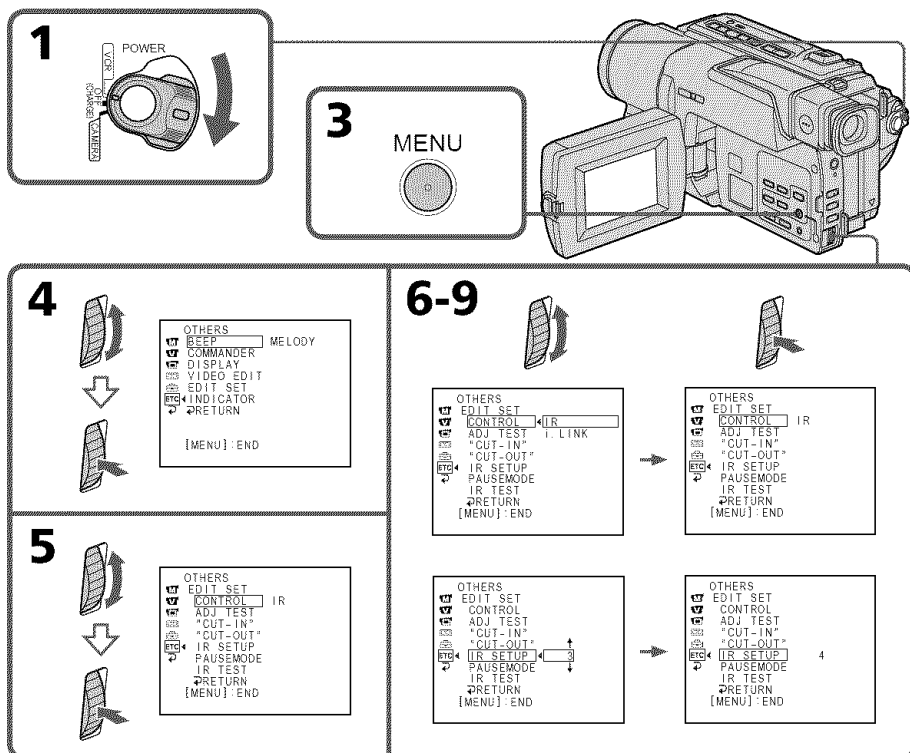

Dubbing only desired scenes – Digital program editing

About the IR SETUP code

The IRSETUP code is stored in the memory of your camcorder. Be sure to set the correct code depending on your VCR. The default setting is Code number 3.

Brand	IR SETUP code
Sony	1, 2, 3, 4, 5, 6
Admiral (M. Wards)	89
Aiwa	80
Audio Dynamic	21, 35
Bell&Howell (M. Wards)	36
Brocsonic	70, 82
Canon	77, 78, 97
Citizen	47
Craig	73, 47
Curtis Mathis	8, 80, 77
Daewoo	26, 40, 77
DBX	21, 33, 35
Dimensia	8
Emerson	26, 82, 59, 48, 70, 81
Fisher	36, 45, 37, 44
Funai	80
General Electric	87, 8, 77, 32*, 94*
Goldstar	47
Hitachi	78, 8, 42
Instant Replay	77, 78
JC Penny	77, 42, 8, 36, 21, 33, 35
JVC	21, 12, 13, 14, 33, 35
Kenwood	21, 33, 47, 35
LXI (Sears)	80, 47, 42, 44, 45, 36, 37
Magnavox	83, 78, 77
Marantz	21, 33, 35
Marta	47
Memorex	77, 37
Minolta	42, 8
Mitsubishi/MGA	28, 22, 23, 24

* TV/VCR component

Note on IR SETUP code

Digital program editing is not possible if the VCR does not support IRSETUP codes.

Brand	IR SETUP code
Multitech	23, 80, 32
NEC	21, 33, 35
Olympic	77, 78
Panasonic	16, 17, 78, 77, 96
Pentax	42, 8
Philco	78, 77
Philips	83, 78, 77
Pioneer	78
Quasar	78, 77, 16, 17
RCA/PROSCAN	8, 42, 16, 77, 83, 7, 40, 41, 78*
Realistic	77, 36
Sansui	21
Singer	73
Samsung	94, 41, 32, 32*, 94*, 24*
Sanyo	36, 37
Scott	40, 41, 32, 37, 28, 22, 23, 24
Sharp	89, 88
Shintom	73
Signature 2000 (M. Wards)	80, 89
Sylvania	83, 78, 77, 80
Symphonic	80
Tashiro	47
Tatung	21, 33, 35
Teac	21, 33, 80, 35
Technics	77, 78
Toshiba	40, 7
Wards	89, 88, 37, 95, 47
Yamaha	36, 21, 33, 35
Zenith	95

Dubbing only desired scenes – Digital program editing

(2) Setting the modes to cancel recording pause on the VCR

- ① Turn the SEL/PUSH EXEC dial to select PAUSEMODE, then press the dial.
- ② Turn the SEL/PUSH EXEC dial to select the mode to cancel recording pause on the VCR, then press the dial.

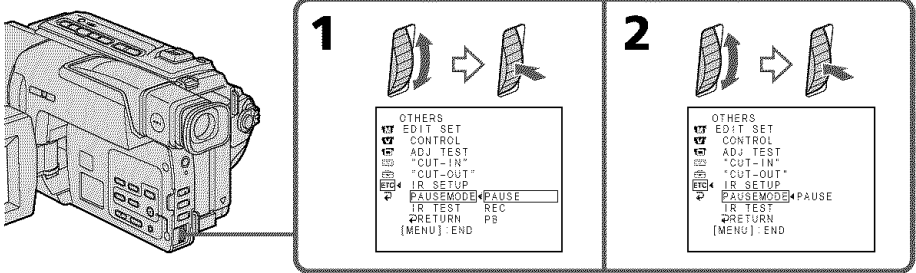

Buttons for canceling recording pause on the VCR

The buttons vary depending on your VCR. To cancel recording pause:

- Select PAUSE if the button to cancel recording pause is **II**.
- Select REC if the button to cancel recording pause is **●**.
- Select PB if the button to cancel recording pause is **▶**.

(3) Setting your camcorder and the VCR to face each other

Locate the infrared rays emitter of your camcorder and face it towards the remote sensor of the VCR.

Set the devices about 30 cm (12 in.) apart, and remove any obstacles between the devices.

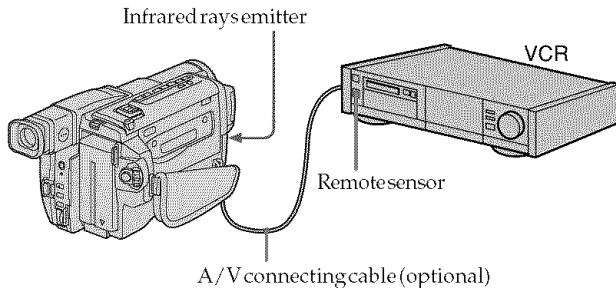

Dubbing only desired scenes – Digital program editing

(4) Confirming the VCR operation

- ① Insert a recordable tape into the VCR, then set to recording pause.
- ② Turn the SEL/PUSH EXEC dial to select IR TEST, then press the dial.
- ③ Turn the SEL/PUSH EXEC dial to select EXECUTE, then press the dial.

If the VCR starts recording, the setting is correct.

When finished, the indicator changes to COMPLETE.

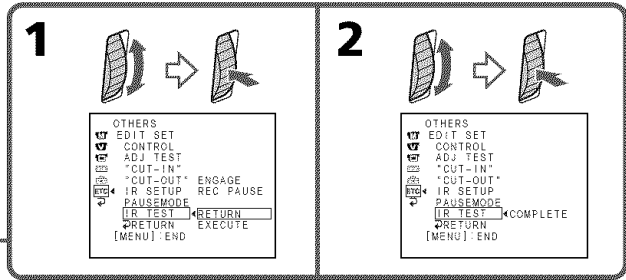
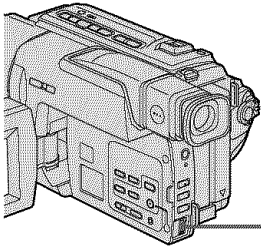

When the VCR does not operate correctly

- After checking the code in "About the IR SETUP code", set the IR SETUP or the PAUSEMODE again.
- Place your camcorder at least 30 cm (12 in.) away from the VCR.
- Refer to the operating instructions of your VCR.

Dubbing only desired scenes – Digital program editing

Step 2: Setting the VCR to operate with the i.LINK cable (DV connecting cable)

When you connect using an i.LINK cable (DV connecting cable) (optional), follow the procedure below.

- (1) Set the POWER switch to VCR on your camcorder.
- (2) Turn the power of the connected VCR on, then set the input selector to DV input.

When you connect a digital video camera recorder, set its POWER switch to VCR/VTR.

- (3) Press MENU to display the menu.
- (4) Turn the SEL/PUSH EXEC dial to select **EDIT**, then press the dial.
- (5) Turn the SEL/PUSH EXEC dial to select EDIT SET, then press the dial.
- (6) Turn the SEL/PUSH EXEC dial to select CONTROL, then press the dial.
- (7) Turn the SEL/PUSH EXEC dial to select i.LINK, then press the dial.

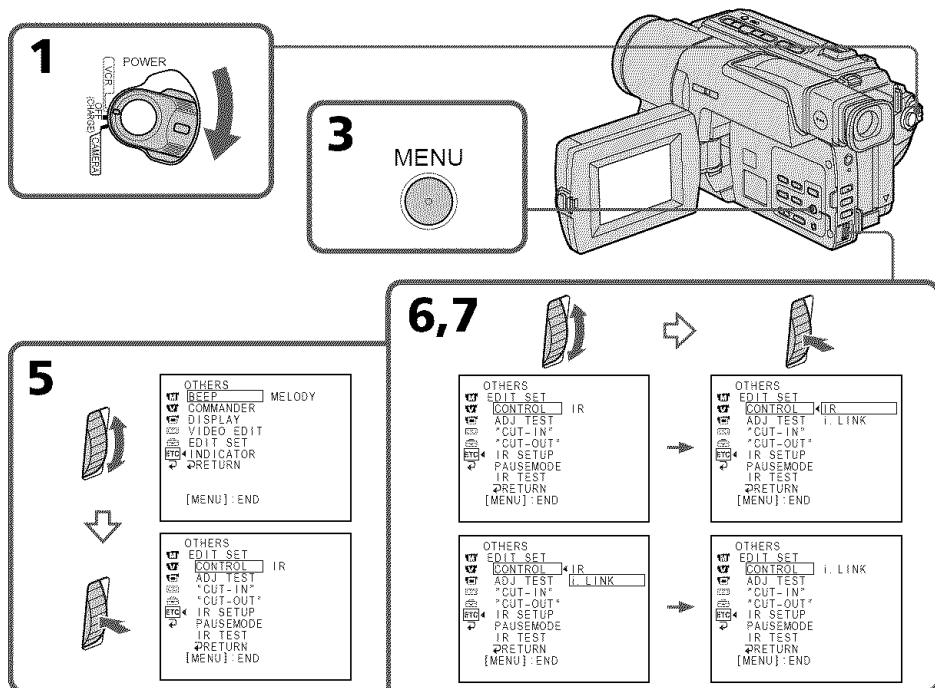

Step 3: Adjusting the synchronicity of the VCR

You can adjust the synchronicity of your camcorder and the VCR. Have a pen and paper ready for notes. Before operation, eject the cassette from your camcorder.

- (1) Set the POWER switch to VCR on your camcorder.
- (2) Insert a blank tape (or a tape you want to record over) into the VCR, then set to recording pause.

When you select i.LINK in CONTROL, you do not need to set to recording pause.

- (3) Turn the SEL/PUSH EXEC dial to select ADJ TEST, then press the dial.
- (4) Turn the SEL/PUSH EXEC dial to select EXECUTE, then press the dial. IN and OUT are recorded on an image for 5 times each to calculate the numerical values for adjusting the synchronicity.

The EXECUTING indicator flashes on the screen. When finished, the indicator changes to COMPLETE.

- (5) Rewind the tape in the VCR, then start slow playback. Take a note of the opening numerical value for each IN and the closing numerical value for each OUT.
- (6) Calculate the average of all the opening numerical values for each IN, and the average of all the closing numerical values for each OUT.
- (7) Turn the SEL/PUSH EXEC dial to select "CUT-IN", then press the dial.
- (8) Turn the SEL/PUSH EXEC dial to select the average numerical value of IN, then press the dial.

The calculated start position for recording is set.

- (9) Turn the SEL/PUSH EXEC dial to select "CUT-OUT", then press the dial.
- (10) Turn the SEL/PUSH EXEC dial to select the average numerical value of OUT, then press the dial.

The calculated stop position for recording is set.

- (11) Turn the SEL/PUSH EXEC dial to select ↶ RETURN, then press the dial.

Dubbing only desired scenes – Digital program editing

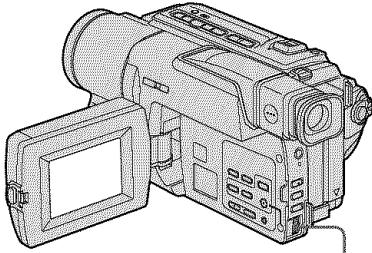

3,4

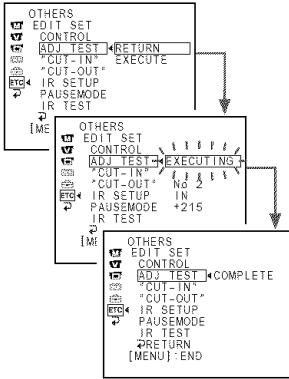

7

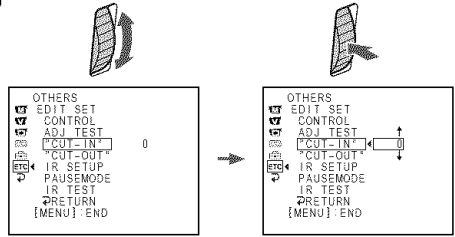

9

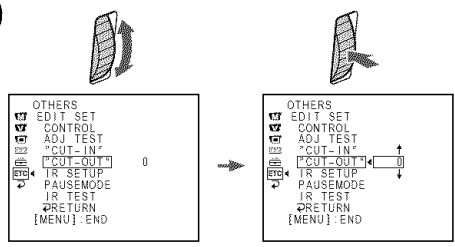

Notes

- When you connect with an i.LINK cable (DV connecting cable), you may not be able to operate the dubbing function correctly, depending on the VCR. Set CONTROL to IR in the menu settings of your camcorder.
- When you complete step 3, the image to adjust the synchronicity is recorded for about 50seconds.
- If you start recording from the very beginning of the tape, the first few seconds of the tape may not record properly. Be sure to allow about 10seconds of lead before starting the recording.

If you connect using an i.LINK cable (DV connecting cable)

With a digital-to-digital connection, video and audio signals are transmitted in digital format for high-quality editing.

Dubbing only desired scenes – Digital program editing

Operation 1: Making the program

- (1) Insert the tape for playback into your camcorder, and insert a tape for recording into the VCR.
- (2) Press MENU to display the menu.
- (3) Turn the SEL/PUSH EXEC dial to select **ETC**, then press the dial.
- (4) Turn the SEL/PUSH EXEC dial to select VIDEO EDIT, then press the dial.
- (5) Search for the beginning of the first scene you want to insert using the video operation buttons, then pause playback.
- (6) Press the SEL/PUSH EXEC dial.
The IN point of the first program is set, and the top part of the program mark changes to light blue.
- (7) Search for the end of the first scene you want to insert using the video operation buttons, then pause playback.
- (8) Press the SEL/PUSH EXEC dial.
The OUT point of the first program is set, then the bottom part of the program mark changes to light blue.
- (9) Set the program by repeating steps 5 to 8.
When the program is set, the program mark changes to light blue.
You can set a maximum of 20 programs.

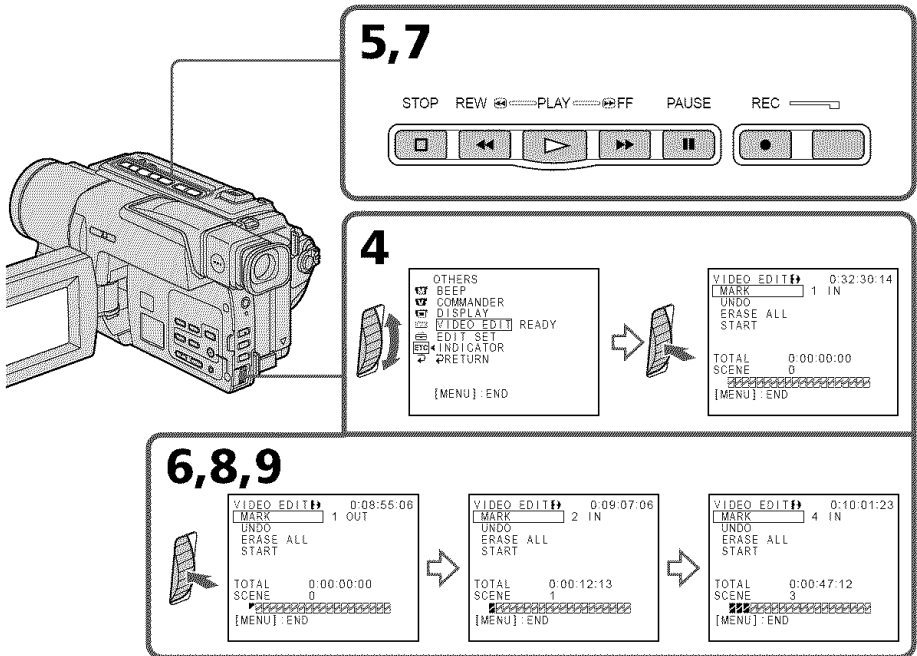

Dubbing only desired scenes – Digital program editing

Erasing the program you have set

Erase OUT first and then IN from the last set program.

- (1) Turn the SEL/PUSH EXEC dial to select UNDO, then press the dial.
- (2) Turn the SEL/PUSH EXEC dial to select EXECUTE, then press the dial.
The last set program mark flashes, then the setting is canceled.

To cancel erasing

Select RETURN in step 2.

Erasing all programs

- (1) Select VIDEO EDIT in the menu settings. Turn the SEL/PUSH EXEC dial to select ERASE ALL, then press the dial.
- (2) Turn the SEL/PUSH EXEC dial to select EXECUTE, then press the dial.
All the program marks flash, then the settings are canceled.

To cancel erasing all programs

Select RETURN in step 2.

To cancel a program you have set

Press MENU.

The program is stored in memory until the tape is ejected.

Note

You cannot operate recording during Digital program editing.

On a blank portion of the tape

You cannot set IN or OUT on a blank portion of the tape.

If there is a blank portion between IN and OUT on the tape

The total time code may not be displayed correctly.

Operation 2: Performing Digital program editing (Dubbing a tape)

Make sure that your camcorder and VCR are connected, and that the VCR is set to recording pause. This procedure is not necessary when you use an i.LINK cable (DV connecting cable).

When you use a digital video camera recorder, set its POWER switch to VCR/VTR.

- (1) Select VIDEO EDIT. Turn the SEL/PUSH EXEC dial to select START, then press the dial.
- (2) Turn the SEL/PUSH EXEC dial to select EXECUTE, then press the dial.
Search for the beginning of the first program, then start dubbing.
The program mark flashes.
The SEARCH indicator appears during a search, and the EDIT indicator appears during editing on the screen.
The program mark changes to light blue after dubbing is complete.
When dubbing ends, your camcorder and the VCR automatically stop.

Dubbing only desired scenes – Digital program editing

To stop dubbing during editing

Press ■ on your camcorder.

To quit the Digital program editing function

Your camcorder stops when dubbing is complete. Then the display returns to VIDEO EDIT in the menu settings.

Press MENU to quit the Digital program editing function.

You cannot record on the VCR when:

- The tape has run out.
- The write-protect tab is set to expose the red mark.
- The IR SETUP code is not correct. (when IR is selected)
- The button to cancel recording pause is not correct. (when IR is selected)

NOT READY appears on the LCD screen when:

- The program to operate Digital program editing has not yet been made.
- i.LINK is selected but an i.LINK cable (DV connecting cable) is not connected.
- The power of the connected VCR is not turned on. (when you set i.LINK.)

Recording from video

You can record a tape from a VCR that has DV outputs. Use your camcorder as a recorder.

Simply connect the i.LINK cable (DV connecting cable) (optional) to **i** DV IN/OUT and to DV IN/OUT of the DV products. With digital-to-digital connection, video and audio signals are transmitted in digital form for high-quality editing.

You cannot take a picture in when you connect your camcorder with other than the i.LINK cable (DV connecting cable).

- (1) Insert a blank tape (or a tape you want to record over) into your camcorder, and insert the recorded tape into the VCR.
- (2) Set the POWER switch to VCR.
- (3) Press ● REC and the button on its right simultaneously on your camcorder, then immediately press ■ on your camcorder.
- (4) Press ▶ on the VCR to start playback.
The picture from a TV or VCR appears on the screen.
- (5) Press ■ on your camcorder at the scene where you want to start recording from.

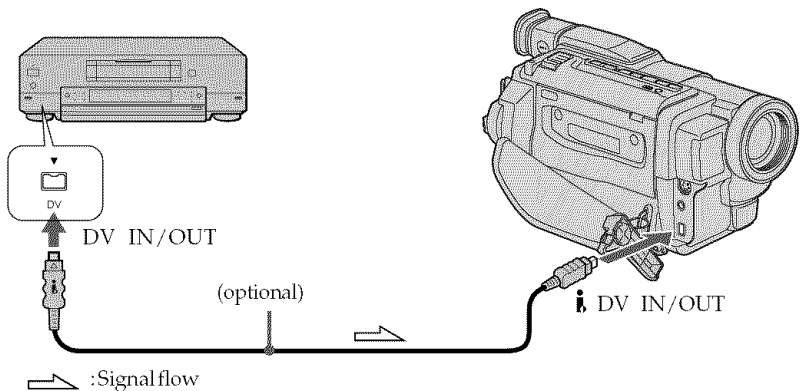

When you have finished dubbing a tape

Press ■ on both your camcorder and the VCR.

You can connect one VCR only using the i.LINK cable (DV connecting cable).

During digital editing

The color of the display may be uneven. However, this does not affect the dubbed picture.

If you record a playback pause picture with the **i** DV IN/OUT jack

The recorded picture becomes rough. And when you play back the picture using your camcorder, the picture may jitter.

Before recording

Make sure if the DV IN indicator appears on the screen by pressing DISPLAY. The DV IN indicator may appear on both equipment.

Inserting a scene from a VCR – Insert Editing

You can insert a new scene from a VCR onto your originally recorded tape using the i.LINK cable (DV connecting cable) (optional) by specifying the insert start and end points.

Use the Remote Commander for this operation.

Connections are the same as in "Recording from video" on page 76. Insert a cassette containing the desired scene to insert into the VCR.

You cannot insert a scene when you connect your camcorder with other than the i.LINK cable (DV connecting cable).

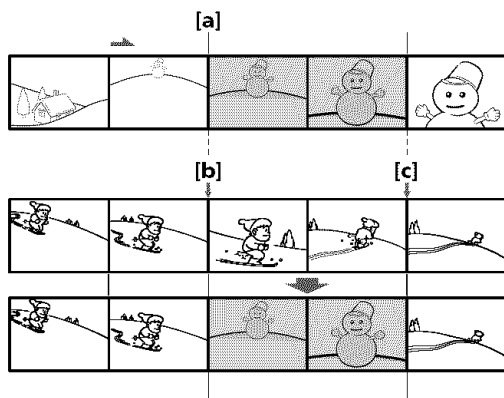

Inserting a scene from a VCR – Insert Editing

- (1) Set the POWER switch to VCR.
- (2) On the VCR, locate just before the insert start point [a], then press **II** to set the VCR to the playback pause mode.
- (3) On your camcorder, locate the insert end point [c] by pressing **◀◀** or **▶▶**. Then press **II** to set it to the playback pause mode.
- (4) Press ZERO SET MEMORY on the Remote Commander. The ZERO SET MEMORY indicator flashes and the end point of the insert is stored in memory.
- (5) On your camcorder, locate the insert start point [b] by pressing **◀◀**, then press **● REC** and the button on its right simultaneously to set your camcorder to the recording pause mode.
- (6) First press **II** on the VCR, and after a few seconds press **II** on your camcorder to start inserting the new scene.
Inserting automatically stops near the zero point on the counter. Your camcorder automatically stops. The end point [c] of the insert stored in memory is canceled.

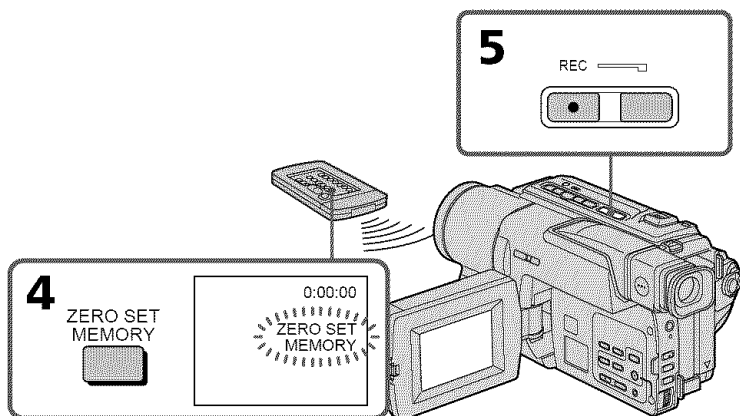

To change the insert end point

Press ZERO SET MEMORY again after step 5 to erase the ZERO SET MEMORY indicator and begin from step 3.

Note

The picture and sound recorded on the section between the insert start and end points will be erased when you insert the new scene.

When the inserted picture is played back

The picture may be distorted at the end of the inserted section. This is not a malfunction.

To insert a scene without setting the insert end point

Skip step 3 and 4. Press **■** when you want to stop inserting.

Changing the menu settings

To change the mode settings in the menu settings, select the menu items with the SEL/PUSH EXEC dial. The default settings can be partially changed. First, select the icon, then the menu item and then the mode.

- (1) In CAMERA or VCR mode, press MENU.
- (2) Turn the SEL/PUSH EXEC dial to select the desired icon, then press the dial to set.
- (3) Turn the SEL/PUSH EXEC dial to select the desired item, then press the dial to set.
- (4) Turn the SEL/PUSH EXEC dial to select the desired mode, and press the dial to set.
- (5) If you want to change other items, select \rightarrow RETURN and press the dial, then repeat steps from 2 to 4.

For details, see “Selecting the mode setting of each item” (p.80).

1

MENU

CAMERA

VCR

MANUAL SET
PROGRAM AE
P EFFECT
D EFFECT
AUTO SHTR
REC LAMP
INDICATOR
[MENU] : END

MANUAL SET
PROGRAM AE
P EFFECT
D EFFECT
REC LAMP
INDICATOR
[MENU] : END

2

OTHERS
WORLD TIME
BEEP
COMMANDER
DISPLAY
REC LAMP
VIDEO EDIT
EDIT SET
INDICATOR

3

OTHERS
WORLD TIME 0 HR
BEEP
COMMANDER ON

4

OTHERS
WORLD TIME
BEEP
COMMANDER NON OFF
DISPLAY
REC LAMP
VIDEO EDIT
EDIT SET
INDICATOR
RETURN





OTHERS
WORLD TIME
BEEP
COMMANDER OFF
DISPLAY
REC LAMP
VIDEO EDIT
EDIT SET
INDICATOR
RETURN

To make the menu display disappear

Press MENU.



Changing the menu settings

Menu items are displayed as the following icons:

-  MANUAL SET
-  CAMERA SET
-  VCR SET
-  LCD SET
-  TAPE SET
-  SETUP MENU
-  OTHERS

Selecting the mode setting of each item ● is the default setting.

Menu items differ according to the position of the POWER switch.
The screen shows only the items you can operate at the moment.

Icon/item	Mode	Meaning	POWER switch
 PROGRAM AE	—	To suit your specific shooting requirement (p. 44)	CAMERA
P EFFECT	—	To add special effects like those in films or on the TV to images (p. 40, 55).	CAMERA VCR
D EFFECT	—	To add special effects using the various digital functions (p. 42, 56).	CAMERA VCR
AUTO SHTR	● ON	To automatically activate the electronic shutter when shooting in bright conditions	CAMERA
	OFF	To not automatically activate the electronic shutter even when shooting in bright conditions	
 D ZOOM	● OFF	To deactivate digital zoom. Up to 20× zoom is carried out.	CAMERA
	40×	To activate digital zoom. More than 20× to 40× zoom is performed digitally. (p. 21)	
	560×	To activate digital zoom. More than 20× to 560× zoom is performed digitally. (p. 21)	
16:9WIDE	● OFF	—	CAMERA
	ON	To record a 16:9 wide picture (p. 36)	
STEADYSHOT	● ON	To compensate for camera-shake	CAMERA
	OFF	To cancel the SteadyShot function. Natural pictures are produced when shooting a stationary object with a tripod.	
N.S. LIGHT	● ON	To use the NightShot Light function (p. 24)	CAMERA
	OFF	To cancel the NightShot Light function	





Notes on the SteadyShot function

- The SteadyShot function will not correct excessive camera-shake.
- Attachment of a conversion lens (optional) may influence the SteadyShot function.

If you cancel the SteadyShot function

The SteadyShot off indicator  appears. Your camcorder prevents excessive compensation for camera-shake.

Changing the menu settings

Icon/item	Mode	Meaning	POWER switch
 HIFI SOUND	● STEREO	To play back a stereo tape or dual sound track tape with main and sub sound	VCR
	1	To play back a stereo tape with the left sound or a dual sound track tape with main sound	
	2	To play back a stereo tape with the right sound or a dual sound track tape with sub sound	
AUDIO MIX	——	To adjust the balance between the stereo 1 and stereo 2	VCR
			
 LCD BRIGHT	——	To adjust the brightness on the LCD screen with the SEL/PUSH EXEC dial.	VCR CAMERA
 <p>To darken ← → To lighten</p>			
LCD B. L.	● BRT NORMAL	To set the brightness on the LCD screen normal	VCR CAMERA
	BRIGHT	To brighten the LCD screen	
LCD COLOR	——	To adjust the color on the LCD screen, turning the SEL/PUSH EXEC dial to adjust the following bar	VCR CAMERA
 <p>To reduce intensity ← → To increase intensity</p>			



Note on AUDIO MIX

When playing back a tape recorded in the 16-bit mode, you cannot adjust the balance.



Notes on LCD B.L.

- When you select BRIGHT, battery life is reduced by about 10 percent during recording.
- When you use power sources other than the battery pack, BRIGHT is automatically selected.

Changing the menu settings

Icon/item	Mode	Meaning	POWER switch
 REC MODE	● SP	To record in the SP (Standard Play) mode	VCR
	LP	To increase the recording time to 1.5 times the SP mode	CAMERA
AUDIO MODE	● 12BIT	To record in the 12-bit mode (two stereo sounds)	CAMERA
	16BIT	To record in the 16-bit mode (the one stereo sound with high quality)	
 REMAIN	● AUTO	To display the remaining tape bar: <ul style="list-style-type: none"> • for about 8 seconds after your camcorder is turned on and calculates the remaining amount of tape • for about 8 seconds after a cassette is inserted and your camcorder calculates the remaining amount of tape • for about 8 seconds after  is pressed in VCR mode • for about 8 seconds after DISPLAY is pressed to display the screen indicators • for the period of tape rewinding, forwarding or picture search in the VCR mode 	VCR CAMERA
	ON	To always display the remaining tape bar	
DATA CODE	● DATE/CAM	To display date, time and recording data during playback	VCR
	DATE	To display date and time during playback	

Note on REC MODE

When you record on the standard 8  tape, your camcorder records in the SP mode even you select the LP mode in the menu settings. In this case, the indicator "8 mm TAPE → SP REC, Hi8 TAPE → LP/SP REC" appears on the screen. Use the Hi8 /Digital 8  tapes for the LP mode.

Notes on the LP mode

- When you record a tape in the LP mode on your camcorder, we recommend playing back the tape on your camcorder. When you play back the tape on other camcorders or VCRs, noise may occur in images or sound.
- When you record in the SP and LP modes on one tape or you record some scenes in the LP mode, the playback image may be distorted or the time code may not be written properly between scenes.

Note on AUDIO MODE

When playing back a tape recorded in the 16-bit mode, you cannot adjust the balance in AUDIO MIX.

Changing the menu settings

Icon/item	Mode	Meaning	POWER switch
 CLOCK SET	—	To set the date or time (p. 16)	CAMERA
AUTO TV ON	● OFF	—	VCR CAMERA
	ON	To automatically turn on the Sony TV when using the super laser link function	
TV INPUT	● VIDEO1 VIDEO2 VIDEO3	To switch the video input on a Sony TV when using the super laser link function (p. 32)	VCR CAMERA
	OFF	—	
LTR SIZE	● NORMAL	To display selected menu items in normal size	VCR CAMERA
	2×	To display selected menu items at twice the normal size	
LANGUAGE	● ENGLISH	To display the following information indicators in English: REC, STBY, min, CAPTURE, END SEARCH and VOL	VCR CAMERA
	FRANÇAIS	To display the information indicators in French	
	ESPAÑOL	To display the information indicators in Spanish	
	PORTUGUÊS	To display the information indicators in Portuguese	
	中文	To display the information indicators in Chinese	
DEMO MODE	● ON	To make the demonstration appear	CAMERA
	OFF	To cancel the demonstration mode	

Notes on DEMO MODE

- You cannot select DEMO MODE when a cassette is inserted in your camcorder.
- DEMO MODE is set to STBY (Standby) at the factory and the demonstration starts about 10 minutes after you have set the POWER switch to CAMERA without a cassette inserted.
To cancel the demonstration, insert a cassette, set the POWER switch to other than CAMERA, or set DEMO MODE to OFF.
- When NIGHTSHOT is set to ON, the "NIGHTSHOT" indicator appears on the screen and you cannot select DEMO MODE in the menu settings.

Changing the menu settings

Icon/item	Mode	Meaning	POWER switch
 WORLD TIME	—	To set the clock to the local time. Turn the SEL/PUSH EXEC dial to set a time difference. The clock changes by the time difference you set here. If you set the time difference to 0, the clock returns to the originally set time.	CAMERA
BEEP	● MELODY	To output the melody when you start/stop recording or when an unusual condition occurs on your camcorder	VCR CAMERA
	NORMAL	To output the beep instead of the melody	
	OFF	To cancel the melody and beep sound	
COMMANDER	● ON	To activate the Remote Commander supplied with your camcorder	VCR CAMERA
	OFF	To deactivate the Remote Commander to avoid remote control misoperation caused by other VCR's remote control	
DISPLAY	● LCD	To show the display on the LCD screen and in the viewfinder	VCR CAMERA
	V-OUT/LCD	To show the display on the TV screen, LCD screen and in the viewfinder	
REC LAMP	● ON	To light up the camera recording lamp at the front of your camcorder	CAMERA
	OFF	To turn the camera recording lamp off so that the subject is not aware of the recording	
VIDEO EDIT	—	To make programs and perform video editing (p. 65).	VCR
EDIT SET	—	To adjust and set the synchronicity of your camcorder and a VCR for dubbing in edit set mode (p. 65).	VCR
INDICATOR	● BL OFF	To turn off the backlight on the display window	VCR CAMERA
	BL ON	To turn on the backlight	

In more than 5 minutes after removing the power source

The AUDIO MIX, COMMANDER and HiFi SOUND items are returned to their default settings.

The other menu items are held in memory even when the battery is removed.



Notes on INDICATOR

- When you select BL ON, battery life is reduced by about 10 percent during recording.
- When you use power sources other than the battery pack, BL ON is automatically selected.

Types of trouble and their solutions

If you run into any problem using your camcorder, use the following table to troubleshoot the problem. If the problem persists, disconnect the power source and contact your Sony dealer or local authorized Sony service facility. If "C: □□:□□" appears on the screen, the self-diagnosis display function has worked. See page 89.

In the recording mode

Symptom	Cause and/or Corrective Actions
START/STOP does not operate.	<ul style="list-style-type: none"> • The POWER switch is set to OFF (CHARGE) or VCR. → Set it to CAMERA. (p. 18) • The tape has run out. → Rewind the tape or insert a new one. (p. 17, 18) • The write-protect tab is set to expose the red mark. → Use a new tape or slide the tab. (p. 17) • The tape is stuck to the drum (moisture condensation). → Remove the cassette and leave your camcorder for at least 1 hour to acclimatize. (p. 97)
The power goes off.	<ul style="list-style-type: none"> • While being operated in CAMERA mode, your camcorder has been in the standby mode for more than 3 minutes. → Set the POWER switch to OFF (CHARGE) and then to CAMERA again. (p. 18) • The battery pack is dead or nearly dead. → Install a fully charged battery pack. (p. 11, 12)
The image on the viewfinder screen is not clear.	<ul style="list-style-type: none"> • The viewfinder lens is not adjusted. → Adjust the viewfinder lens. (p. 22)
The SteadyShot function does not work.	<ul style="list-style-type: none"> • STEADYSHOT is set to OFF in the menu settings. → Set it to ON. (p. 80) • 16:9WIDE is set to ON in the menu settings. → Set it to OFF. (p. 80)
The autofocusing function does not work.	<ul style="list-style-type: none"> • FOCUS is set to MANUAL. → Set it to AUTO. (p. 47) • Shooting conditions are not suitable for autofocus. → Set FOCUS to MANUAL to focus manually. (p. 47)
The picture does not appear in the viewfinder.	<ul style="list-style-type: none"> • The LCD panel is open. → Close the LCD panel. (p. 19)
You cannot record in the LP mode.	<ul style="list-style-type: none"> • The tape is the standard 8 tape. → Use Hi8 /Digital8  tapes. (p. 92)
A vertical band appears when you shoot a subject such as lights or a candle flame against a dark background.	<ul style="list-style-type: none"> • The contrast between the subject and background is too high. This is not a malfunction.
A vertical band appears when you shoot a very bright subject.	<ul style="list-style-type: none"> • This is not a malfunction.
Some tiny white spots appear on the screen.	<ul style="list-style-type: none"> • Slow shutter, low lux or Super NightShot mode is activated. This is not a malfunction.

(Continued on the following page)

Types of trouble and their solutions



Symptom	Cause and/or Corrective Actions
An unknown picture is displayed on the screen.	<ul style="list-style-type: none"> • If 10 minutes elapse after you set the POWER switch to CAMERA or DEMO MODE is set to ON in the menu settings without a cassette inserted, your camcorder automatically starts the demonstration. <ul style="list-style-type: none"> → Insert a cassette and the demonstration stops. You can also cancel DEMO MODE. (p. 83)
The picture is recorded in incorrect or unnatural colors.	<ul style="list-style-type: none"> • NIGHTSHOT is set to ON. <ul style="list-style-type: none"> → Set it to OFF. (p. 24)
The picture appears too bright, and the subject does not appear on the screen.	<ul style="list-style-type: none"> • NIGHTSHOT is set to ON in a bright place. <ul style="list-style-type: none"> → Set it to OFF, or use the NightShot function in a dark place. (p. 24) • The backlight function is working. <ul style="list-style-type: none"> → Cancel it.
A horizontal black band appears when shooting a TV screen or computer screen.	<ul style="list-style-type: none"> • Set STEADYSHOT to OFF in the menu setting. (P. 80)

In the playback mode

Symptom	Cause and/or Corrective Actions
The picture does not appear on the screen when playing back a tape.	<ul style="list-style-type: none"> • The tape is recorded in the Hi8 Hi8/Standard 8 8 (analog) system.
The tape does not move when a video control button is pressed.	<ul style="list-style-type: none"> • The POWER switch is set to CAMERA or OFF (CHARGE). <ul style="list-style-type: none"> → Set it to VCR. (p. 27)
The playback button does not work.	<ul style="list-style-type: none"> • The tape has run out. <ul style="list-style-type: none"> → Rewind the tape. (p. 27)
There are horizontal lines on the picture or the playback picture is not clear or does not appear.	<ul style="list-style-type: none"> • The video head may be dirty. <ul style="list-style-type: none"> → Clean the heads using the Sony V8-25CLD cleaning cassette (optional). (p. 98)
No sound or only a low sound is heard when playing back a tape.	<ul style="list-style-type: none"> • The stereo tape is played back with HiFi SOUND set to 2 in the menu settings. <ul style="list-style-type: none"> → Set it to STEREO. (p. 81) • The volume is turned to minimum. <ul style="list-style-type: none"> → Open the LCD panel and press VOLUME +. (p. 24) • AUDIO MIX is set to ST2 side in the menu settings. <ul style="list-style-type: none"> → Adjust AUDIO MIX. (p. 81)
The date search does not work correctly.	<ul style="list-style-type: none"> • The tape has a blank portion in the recorded portion (p. 59)

Types of trouble and their solutions

In the recording and playback modes

Symptom	Cause and/or Corrective Actions
The power does not turn on.	<ul style="list-style-type: none">• The battery pack is not installed, or is dead or nearly dead. → Install a charged battery pack. (p. 11, 12)• The AC power adaptor is not connected to a wall outlet. → Connect the AC power adaptor to a wall outlet. (p. 15)
The end search function does not work.	<ul style="list-style-type: none">• The tape was ejected after recording.• You have not recorded on the new cassette yet.
The end search function does not work correctly.	<ul style="list-style-type: none">• The tape has a blank portion in the beginning or middle.
The battery pack is quickly discharged.	<ul style="list-style-type: none">• The operating temperature is too low.• The battery pack is not fully charged. → Charge the battery pack fully again. (p. 11, 12)• The battery pack is completely dead, and cannot be recharged. → Replace with a new battery pack. (p. 11)
The remaining battery time indicator does not indicate the correct time.	<ul style="list-style-type: none">• You have used the battery pack in an extremely hot or cold environment for a long time.• The battery pack is completely dead, and cannot be recharged. → Replace with a new battery pack. (p. 11)• The battery pack is not fully charged. → Charge the battery pack fully again. (p. 11, 12)• A deviation has occurred in the remaining battery time. → Charge the battery pack fully again. (p. 11, 12)
The power goes off although the remaining battery time indicator indicates that the battery pack has enough power to operate.	<ul style="list-style-type: none">• A deviation has occurred in the remaining battery time. → Charge the battery pack fully again. (p. 11, 12)
The cassette cannot be removed from the holder.	<ul style="list-style-type: none">• The power source is disconnected. → Connect it firmly. (p. 12, 15)• The battery pack is dead. → Use a charged battery pack. (p. 11, 12)
The  and  indicators flash and no functions except for cassette ejection work.	<ul style="list-style-type: none">• Moisture condensation has occurred. → Remove the cassette and leave your camcorder for at least 1 hour to acclimatize. (p. 97)
Remaining tape indicator is not displayed.	<ul style="list-style-type: none">• The  REMAIN is set to AUTO in the menu settings. → Set it to ON to always display the remaining tape indicator.

(Continued on the following page)

Types of trouble and their solutions

Others

Symptom	Cause and/or Corrective Actions
Digital program editing does not function.	<ul style="list-style-type: none">• The input selector on the VCR is not set correctly. → Set the selector correctly, and check the connection between the VCR and your camcorder (p. 65)• The camcorder is connected to DV equipment of other than Sony using the i.LINK cable (DV connecting cable). → Keep the connection, and follow the procedure on page 70.• Setting program on a blank portion of the tape is attempted. → Set the program again on a recorded portion (p. 73).• The synchronicity of your camcorder and the VCR is not adjusted. → Adjust the synchronicity of the VCR (p. 71).
The Remote Commander supplied with your camcorder does not work.	<ul style="list-style-type: none">• COMMANDER is set to OFF in the menu settings. → Set it to ON. (p. 84)• Something is blocking the infrared rays. → Remove the obstacle.• The batteries are inserted in the battery holder with the + – polarities incorrectly matching the + – marks. → Insert the batteries with the correct polarity. (p. 108)• The batteries are dead. → Insert new ones. (p. 108)
The melody or beep sounds for 5 seconds.	<ul style="list-style-type: none">• Moisture condensation has occurred. → Remove the cassette and leave your camcorder for at least 1 hour to acclimatize. (p. 97)• Some troubles have occurred in your camcorder. → Remove the cassette and insert it again, then operate your camcorder.
No function works though the power is on.	<ul style="list-style-type: none">• Disconnect the power code of the AC power adaptor or remove the battery pack, then reconnect it in about 1 minute. Turn the power on (p. 12, 15). If the functions still do not work, press the RESET button using a sharp-pointed object. (If you press the RESET button, all the settings including the date and time return to the default.) (p. 105)
While charging the battery pack, the CHG lamp does not light up.	<ul style="list-style-type: none">• The AC power adaptor is disconnected. → Connect it firmly. (p. 15)• Charging has been completed.• The battery pack is not installed properly. → Install the battery pack properly. (p. 11)• Something is wrong with the battery pack. → Contact your Sony dealer or local authorized Sony service facility.
While charging the battery pack, the CHG lamp flashes.	<ul style="list-style-type: none">• Something is wrong with the battery pack. → Contact your Sony dealer or local authorized Sony service facility.
You cannot charge the battery pack installed to your camcorder.	<ul style="list-style-type: none">• The POWER switch is not set to OFF (CHARGE). → Set it to OFF (CHARGE).
The power goes off although the remaining battery time indicator indicates that the battery pack has enough power to operate.	<ul style="list-style-type: none">• A deviation has occurred in the remaining battery time. → Charge the battery pack fully again. (p. 11, 12)

Self-diagnosis display

Your camcorder has a self-diagnosis display function.

This function displays the current condition of your camcorder as a 5-digit code (a combination of a letter and figures) on the LCD screen, in the viewfinder or in the display window.

If a 5-digit code is displayed, check the following code chart. The last two digits (indicated by □□) will differ depending on the state of your camcorder.

LCD screen, viewfinder or display window

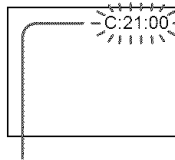

Self-diagnosis display

• C:□□:□□

You can service your camcorder yourself.

• E:□□:□□

Contact your Sony dealer or local authorized Sony service facility.

Five-digit display	Cause and/or Corrective Actions
C:04:□□	<ul style="list-style-type: none"> You are using a battery pack that is not an "InfoLITHIUM" battery pack. → Use an "InfoLITHIUM" battery pack. (p. 93)
C:21:□□	<ul style="list-style-type: none"> Moisture condensation has occurred. → Remove the cassette and leave your camcorder for at least 1 hour to acclimatize. (p. 97)
C:22:□□	<ul style="list-style-type: none"> The video heads are dirty. → Clean the heads using the Sony V8-25CLD cleaning cassette (optional). (p. 98)
C:31:□□ C:32:□□	<ul style="list-style-type: none"> A malfunction other than the above that you can service has occurred. → Remove the cassette and insert it again, then operate your camcorder. → Disconnect the power cord of the AC power adaptor or remove the battery pack. After reconnecting the power source, operate your camcorder.
E:61:□□ E:62:□□	<ul style="list-style-type: none"> A malfunction that you cannot service has occurred. → Contact your Sony dealer or local authorized Sony service facility and inform them of the 5-digit code. (example: E:61:10)

If you are unable to rectify the problem even if you try corrective actions a few times, contact your Sony dealer or local authorized Sony service facility.

Warning indicators and messages

If indicators and messages appear on the screen, check the following:
See the page in parentheses“()” for more information.

Warning indicators

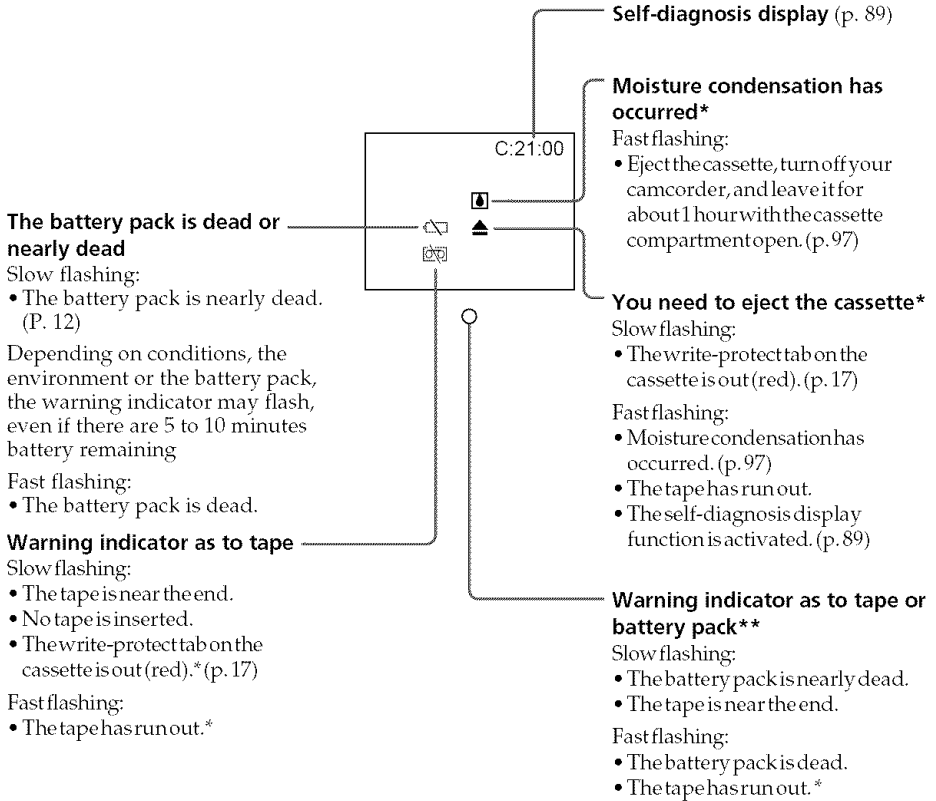







* You hear the melody or beep sound.



* This indicator appears in the viewfinder only.

Warning indicators and messages

Warning messages



- CLOCK SET Set the date and time. (p. 16)
- FOR "InfoLITHIUM"
BATTERY ONLY Use an "InfoLITHIUM" battery pack. (p. 93)
-   TAPE END The tape has run out.*
-  NO TAPE Insert a cassette tape.*
-  CLEANING CASSETTE** The video heads are dirty. (p. 98)
- COPY INHIBIT You tried to record a picture that has a copyright control signal.* (p. 92)
- 8 mm TAPE → SP REC Use Hi8 /Digital 8  tapes when you record
Hi8 TAPE → LP/SP REC in the LP mode.* (p. 82)

* You hear the melody or beep sound.

* The  indicator and "  CLEANING CASSETTE" message appear one after another on the screen.



About video cassettes

What is the “Digital8 system”?



This video system has been developed to enable digital recording to Hi8 /Digital8  video cassette.

Usable cassette tapes

We recommend using Hi8 /Digital8  video cassettes.

If you use standard 8  tape, be sure to play back the tape on this camcorder. Mosaic pattern noise may appear when you play back standard 8  tape on other VCRs (including other DCR-TRV130).

Note

Tapes recorded in the Digital8  system cannot be played back on Hi8 /standard 8  (analog) system machine.



 is a trademark.

 is a trademark.

 is a trademark.

Playback system

You can play back the tapes recorded only in the Digital8  system.

Tapes recorded in the Hi8 /standard 8  (analog) system cannot be played back with your camcorder.

When you play back

Playing back on a PAL-recorded tape

You can play back tapes recorded in the PAL video system on the LCD screen*, if the tape is recorded in the SP mode.

* The picture does not appear neither in the viewfinder nor on the TV.

Copyright signal

When you play back

Using any other video camera recorder, you cannot record on a tape that has recorded copyright control signals for copyright protection of software which is played back on your camcorder.

When you record

You cannot record software on your camcorder that contains copyright control signals for copyright protection of software.

COPY INHIBIT appears on the LCD screen, in the viewfinder or on the TV screen if you try to record such software. Your camcorder does not record copyright control signals on the tape when it records.

When you play back a dual sound track tape

When you play back a tape which is dubbed from a dual sound track tape recorded in the DV system, set HiFi SOUND to the desired mode in the menu settings (p. 81).

Sound from speaker

HiFi Sound Mode	Playing back a stereo tape	Playing back a dual sound track tape
STEREO	Stereo	Main sound and sub sound
1	Lch	Main sound
2	Rch	Subsound

You cannot record dual sound programs on your camcorder.

About the “InfoLITHIUM” battery pack

What is the “InfoLITHIUM” battery pack?

The “InfoLITHIUM” battery pack is a lithium-ion battery pack that has functions for communicating information related to operating conditions between your camcorder and the AC power adaptor.

The “InfoLITHIUM” battery pack calculates the power consumption according to the operating conditions of your camcorder, and displays the remaining battery time in minutes.

Charging the battery pack

- Be sure to charge the battery pack before you start using your camcorder.
- We recommend charging the battery pack in an ambient temperature of between 10°C to 30°C (50°F to 86°F) until the CHG lamp goes out, indicating that the battery pack is fully charged. If you charge the battery pack outside of this temperature range, you may not be able to efficiently charge the battery pack.
- After charging is completed, either disconnect the cable from the DC IN jack on your camcorder or remove the battery pack.

Effective use of the battery pack

- Battery performance decreases in low-temperature surroundings. So, the time that the battery pack can be used is shorter in cold places. We recommend the following to use the battery pack longer:
 - Put the battery pack in a pocket close to your body to warm it up, and insert it in your camcorder immediately before you start taking shots.
 - Use the large capacity battery pack (NP-F730/F730H/F750/F930/F950/F960, optional).
- Frequently using the LCD panel or frequently operating playback, fast forward or rewind wears out the battery pack faster. We recommend using the large capacity battery pack (NP-F730/F730H/F750/F930/F950/F960, optional).
- Be certain to turn the POWER switch to OFF (CHARGE) when not taking shots or playing back on your camcorder. The battery pack is also consumed when your camcorder is in the standby mode or playback is paused.
- Have spare battery packs handy for two or three times the expected recording time, and make a trial recording before the actual recording.
- Do not expose the battery pack to water. The battery pack is not water-resistant.

Remaining battery time indicator

- If the power goes off although the remaining battery time indicator indicates that the battery pack has enough power to operate, charge the battery pack fully again so that the indication on the remaining battery time indicator is correct. Note, however, that the correct battery indication sometimes will not be restored if it is used in high temperatures for a long time or left in a fully charged state, or the battery pack is frequently used. Regard the remaining battery time indication as the approximate shooting time.
- The  mark indicating there is little remaining battery time sometimes flashes depending on the operating conditions or ambient temperature and environment even if the remaining battery time is 5 to 10 minutes.

How to store the battery pack

- Even if the battery pack is not used for a long time, store it in a dry, cool place after fully charging it once per year and then using the battery pack up on your camcorder. This is to maintain the battery pack's functions.
- To use the battery pack up on your camcorder, leave your camcorder in the shooting mode until the power goes off without a cassette inserted.

Battery life

- The battery life is limited. Battery capacity drops little by little as you use it more and more, and as time passes. When the available battery time is shortened considerably, a probable cause is that the battery pack has reached the end of its life. Please buy a new battery pack.
- The battery life varies according to how it is stored and operating conditions and environment for each battery pack.

About i.LINK

The DV jack on this unit is an i.LINK-compliant DV input/output jack. This section describes the i.LINK standard and its features.

What is “i.LINK”?

i.LINK is a digital serial interface for handling digital video, digital audio and other data in two directions between equipment having the i.LINK jack, and for controlling other equipment.

i.LINK-compatible equipment can be connected by a single i.LINK cable. Possible applications are operations and data transactions with various digital AV equipment. When two or more i.LINK-compatible equipment are connected to this unit in a daisy chain, operations and data transactions are possible with not only the equipment that this unit is connected to but also with other devices via the directly connected equipment.

Note, however, that the method of operation sometimes varies according to the characteristics and specifications of the equipment to be connected, and that operations and data transactions are sometimes not possible on some connected equipment.

Note

Normally, only one piece of equipment can be connected to this unit by the i.LINK cable (DV connecting cable). When connecting this unit to i.LINK-compatible equipment having two or more i.LINK jacks (DV jacks), refer to the instruction manual of the equipment to be connected.

About the Name “i.LINK”

i.LINK is a more familiar term for IEEE 1394 data transport bus proposed by SONY, and is a trademark approved by many corporations.

IEEE 1394 is an international standard standardized by the Institute of Electrical and Electronic Engineers.

i.LINK Baud rate

i.LINK's maximum baud rate varies according to the equipment. Three maximum baud rates are defined:

S100 (approx. 100Mbps*)

S200 (approx. 200Mbps)

S400 (approx. 400Mbps)

The baud rate is listed under “Specifications” in the instruction manual of each equipment. It is also indicated near the i.LINK jack on some equipment.

The maximum baud rate of equipment on which it is not indicated such as this unit is “S100”.

When units are connected to equipment having a different maximum baud rate, the baud rate sometimes differs from the indicated baud rate.

* What is “Mbps”?

Mbps stands for megabits per second, or the amount of data that can be sent or received in one second. For example, a baud rate of 100Mbps means that 100 megabits of data can be sent in one second.

About i.LINK

i.LINK Functions on this unit

For details on how to dub when this unit is connected to other video equipment having DV jacks, see page 64.

This unit can also be connected to other i.LINK (DV) compatible equipment made by SONY (e.g. VAIO series personal computer) other than video equipment.

Before connecting this unit to a personal computer, make sure that application software supported by this unit is already installed on the personal computer.

For details on precautions when connecting this unit, also refer to the instruction manuals for the equipment to be connected.

Required i.LINK Cable

Use the Sony i.LINK 4-pin-to-4-pin cable (during DV dubbing).

i.LINK and  are trademarks.

Using your camcorder abroad

Using your camcorder abroad

You can use your camcorder in any country or area with the AC power adaptor supplied with your camcorder within 100 V to 240 V AC, 50/60 Hz.

When charging the battery pack, use a commercially available AC plug adaptor [a], if necessary, depending on the design of the wall outlet [b].

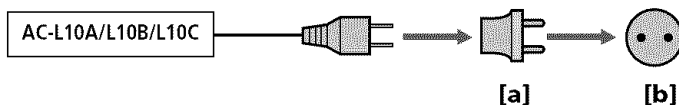

Your camcorder is an NTSC system based camcorder. If you want to view the playback picture on a TV, it must be an NTSC system based TV with VIDEO/AUDIO input jack. The following shows TV color systems used overseas.

NTSC system

Bahama Islands, Bolivia, Canada, Central America, Chile, Colombia, Ecuador, Jamaica, Japan, Korea, Mexico, Peru, Surinam, Taiwan, the Philippines, the U.S.A., Venezuela, etc.

PAL system

Australia, Austria, Belgium, China, Czech Republic, Denmark, Finland, Germany, Great Britain, Holland, Hong Kong, Italy, Kuwait, Malaysia, New Zealand, Norway, Portugal, Singapore, Slovak Republic, Spain, Sweden, Switzerland, Thailand, etc.

PAL-M system

Brazil

PAL-N system

Argentina, Paraguay, Uruguay

SECAM system



Bulgaria, France, Guyana, Hungary, Iran, Iraq, Monaco, Poland, Russia, Ukraine, etc.

Simple setting of clock by time difference

You can easily set the clock to the local time by setting a time difference. Select WORLD TIME in the menu settings. See page 84 for more information.

Maintenance information and precautions

Moisture condensation

If your camcorder is brought directly from a cold place to a warm place, moisture may condense inside your camcorder, on the surface of the tape, or on the lens. In this condition, the tape may stick to the head drum and be damaged or your camcorder may not operate correctly. If there is moisture inside your camcorder, the beep sounds and the  indicator flashes. When the  indicator flashes at the same time, the cassette is inserted in your camcorder. If moisture condenses on the lens, the indicator will not appear.

If moisture condensation occurs

None of the functions except cassette ejection will work. Eject the cassette, turn off your camcorder, and leave it for about 1 hour with the cassette compartment open. Your camcorder can be used again if the  indicator does not appear when the power is turned on again.

Note on moisture condensation

Moisture may condense when you bring your camcorder from a cold place into a warm place (or vice versa) or when you use your camcorder in a hot place as follows:

- You bring your camcorder from a ski slope into a place warmed up by a heating device.
- You bring your camcorder from an air-conditioned car or room into a hot place outside.
- You use your camcorder after a squall or a shower.
- You use your camcorder in a high temperature and humid place.

How to prevent moisture condensation

When you bring your camcorder from a cold place into a warm place, put your camcorder in a plastic bag and tightly seal it. Remove the bag when the air temperature inside the plastic bag has reached the surrounding temperature (after about 1 hour).

Maintenance information and precautions

Maintenance information



Cleaning the LCD screen

If fingerprints or dust make the LCD screen dirty, we recommend using a LCD Cleaning Kit (optional) to clean the LCD screen.

Cleaning the video head

To ensure normal recording and clear pictures, clean the video heads.

The video head may be dirty when:

- mosaic-pattern noise appears on the playback picture.
- playback pictures do not move.
- playback pictures are hardly visible.
- playback pictures do not appear.
- the  indicator and "  CLEANING CASSETTE" message appear one after another on the screen.



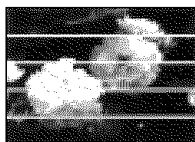

or



If the above problem occurs, clean the video heads with the Sony V8-25CLD cleaning cassette (optional). Check the picture and if the above problems persist, repeat cleaning.

Removing dust from inside the viewfinder

- (1)  Remove the screw with a screwdriver (not supplied).  Then, while holding the RELEASE knob up,  turn the eyecup in a counterclockwise direction and pull it out.
- (2) Clean the surface with a commercially available blower for a still camera.
- (3) Turn the eyecup in a clockwise direction, then replace the screw.

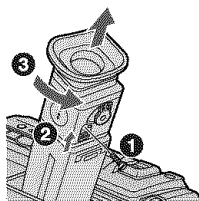

Caution

Do not remove any other screws. You may remove only the screw to remove the eyecup.

Maintenance information and precautions

Charging the built-in rechargeable lithium cell

Your camcorder is supplied with a built-in rechargeable lithium cell so as to retain the date and time, etc., regardless of the setting of the POWER switch. The rechargeable lithium cell is always charged as long as you are using your camcorder. The cell, however, will get discharged in about 4 months if you do not use your camcorder at all. Even if the rechargeable lithium cell is not charged, it will not affect the camcorder operation. To retain the date and time, etc., charge the cell if the cell is discharged.

Charging the built-in rechargeable lithium cell

- Connect your camcorder to house current using the AC power adaptor supplied with your camcorder, and leave your camcorder with the POWER switch turned off for more than 24 hours.
- Or install the fully charged battery pack in your camcorder, and leave your camcorder with the POWER switch turned off for more than 24 hours.

Precautions

Camcorder operation

- Operate your camcorder on 7.2 V (battery pack) or 8.4 V (AC power adaptor).
- For DC or AC operation, use the accessories recommended in this operating instructions.
- If any solid object or liquid get inside the casing, unplug your camcorder and have it checked by a Sony dealer before operating it any further.
- Avoid rough handling or mechanical shock. Be particularly careful of the lens.
- Keep the POWER switch set to OFF (CHARGE) when you are not using your camcorder.
- Do not wrap your camcorder with a towel, for example, and operate it. Doing so might cause heat to build up inside.
- Keep your camcorder away from strong magnetic fields or mechanical vibration. Noise may appear on the image.
- Do not touch the LCD screen with your fingers or a sharp-pointed object.
- If your camcorder is used in a cold place, a residual image may appear on the LCD screen. This is not a malfunction.
- While using your camcorder, the back of the LCD screen may heat up. This is not a malfunction.

Built-in light

- Do not knock or jolt the built-in light while it is turned on as it may damage the bulb or shorten the life of the bulb.
- Do not leave the built-in light on while it is resting on or against something; it may cause a fire or damage the built-in light.



On handling tapes

Do not insert anything into the small holes on the rear of the cassette. These holes are used to sense the type and thickness of the tape and if the recording tab is in or out.

Camcorder care

- Remove the tape, and periodically turn on the power, operate the CAMERA and VCR sections and play back a tape for about 3 minutes when your camcorder is not to be used for a long time.
- Clean the lens with a soft brush to remove dust. If there are fingerprints on the lens, remove them with a soft cloth.
- Clean the camcorder body with a dry soft cloth, or a soft cloth lightly moistened with a mild detergent solution. Do not use any type of solvent which may damage the finish.
- Do not let sand get into your camcorder. When you use your camcorder on a sandy beach or in a dusty place, protect it from the sand or dust. Sand or dust may cause your camcorder to malfunction, and sometimes this malfunction cannot be repaired.

Connection to your personal computer

When recording the image processed or edited by your personal computer with the i.LINK cable (DV connecting cable), use a new Hi8 /Digital8  tape.

AC power adaptor

- Unplug the unit from the wall outlet when you are not using the unit for a long time. To disconnect the power cord, pull it out by the plug. Never pull the power cord itself.
- Do not operate the unit with a damaged cord or if the unit has been dropped or damaged.
- Do not bend the power cord forcibly, or place a heavy object on it. This will damage the cord and may cause fire or electrical shock.
- Prevent metallic objects from coming into contact with the metal parts of the connecting section. If this happens, a short may occur and the unit may be damaged.
- Always keep metal contacts clean.
- Do not disassemble the unit.
- Do not apply mechanical shock or drop the unit.
- While the unit is in use, particularly during charging, keep it away from AM receivers and video equipment. AM receivers and video equipment disturb AM reception and video operation.
- The unit becomes warm during use. This is not a malfunction.
- Do not place the unit in locations that are:
 - Extremely hot or cold
 - Dusty or dirty
 - Very humid
 - Vibrating

About care and storage of the lens

- Wipe the surface of the lens clean with a soft cloth in the following instances:
 - When there are fingerprints on the lens surface
 - In hot or humid locations
 - When the lens is used in environments susceptible to salt such as the seaside
- Store the lens in a well-ventilated location subject to little dirt or dust.

To prevent mold from occurring, periodically perform the above.

We recommend turning on and operating your camcorder about once per month to keep your camcorder in an optimum state for a long time.

Battery pack

- Use only the specified charger or video equipment with the charging function.
- To prevent an accidental short circuit, do not allow metal objects to come into contact with the battery terminals.
- Keep the battery pack away from fire.
- Never expose the battery pack to temperatures above 60°C (140°F), such as in a car parked in the sun or under direct sunlight.
- Keep the battery pack dry.
- Do not expose the battery pack to any mechanical shock.
- Do not disassemble nor modify the battery pack.
- Attach the battery pack to the video equipment securely.
- Charging while some capacity remains does not affect the original battery capacity.

Note on dry batteries

To avoid possible damage from battery leakage or corrosion, observe the following:

- Be sure to insert the batteries with the + – polarities matched to the + – marks.
- Dry batteries are not rechargeable.
- Do not use a combination of new and old batteries.
- Do not use different types of batteries.
- Current flows from batteries when you are not using them for a long time.
- Do not use leaking batteries.

If batteries are leaking

- Wipe off the liquid in the battery compartment carefully before replacing the batteries.
- If you touch the liquid, wash it off with water.
- If the liquid get into your eyes, wash your eyes with a lot of water and then consult a doctor.

If any problem occurs, unplug your camcorder and contact your nearest Sony dealer.

Specifications

Video camera recorder

System

Video recording system

2 rotary heads

Helical scanning system

Audio recording system

Rotary heads, PCM system

Quantization: 12 bits (Fs 32 kHz, stereo 1, stereo 2), 16 bits (Fs 48 kHz, stereo)

Video signal

NTSC color, EIA standards

Usable cassette

Hi8/Digital8 video cassette

Recording/playback time (using 120 min. Hi8/Digital8 video cassette)

SP mode: 1 hour

LP mode: 1 hour and 30 minutes

Fastforward/rewind time (using 120 min. Hi8/Digital8 video cassette)

Approx. 5 min.

Viewfinder

Electric Viewfinder (monochrome)

Image device

4.5 mm (1/4 type) CCD (Charge Coupled Device)

Approx. 460 000 pixels (Effective: Approx. 290 000 pixels)

Approx. 460 000 pixels

Approx. 460 000 pixels

Lens

Combined power zoom lens

Filter diameter 37 mm (1 7/16 in.)

20× (Optical), 560× (Digital)

Focal length

3.6 - 72 mm (5/32 - 2 7/8 in.)

When converted to a 35 mm still camera

41 - 820 mm (1 5/8 - 32 3/8 in.)

Color temperature

Auto

Minimum illumination

1 lx (lux) (F 1.4)

0 lx (lux) (in the NightShot mode)*

* Objects unable to be seen due to the dark can be shot with infrared lighting.

Input/output connectors

5 video output

4-pin mini DIN

Luminance signal: 1 V_{p-p},

75 Ω (ohms), unbalanced

Chrominance signal: 0.286 V_{p-p},

75 Ω (ohms), unbalanced

Audio/Video output

AV MINIJACK, 1 V_{p-p}, 75 Ω

(ohms), unbalanced, sync

negative 327 mV, (at output

impedance more than 47 kΩ

(kilohms))

Output impedance with less

than 2.2 kΩ (kilohms)/Stereo

minijack

(ø 3.5 mm)

⚡ DV input/output

4-pin connector

Headphone jack

Stereo minijack (ø 3.5 mm)

LCD screen

Picture

6.2 cm (2.5 type)

50.3 × 37.4 mm (2 × 1 1/2 in.)

Total dot number

61 600 (280 × 220)

General

Power requirements

7.2 V (battery pack)

8.4 V (AC power adaptor)

Average power consumption

(when using the battery

pack)

During camera recording

using LCD

3.5 W

Viewfinder

3.1 W

Operating temperature

0 °C to 40 °C (32 °F to 104 °F)

Recommended charging temperature

10 °C to 30 °C (50 °F to 86 °F)

Storage temperature

-20 °C to +60 °C

(-4 °F to +140 °F)

Dimensions (Approx.)

104 × 109 × 223 mm

(4 1/8 × 4 3/8 × 9 1/8 in.)

(w/h/d)

Mass (approx.)

950 g (2lb)

excluding the battery pack,

cassette and shoulder strap

1.1 kg (2 lb 7oz)

including the battery pack

NP-F330, 120min. Hi8/Digital8

cassette, and shoulder strap

Supplied accessories

See page 10.

AC power adaptor

Power requirements

100 - 240 V AC, 50/60 Hz

Power consumption

23 W

Output voltage

DC OUT: 8.4 V, 1.5 A in the

operating mode

Operating temperature

0 °C to 40 °C (32 °F to 104 °F)

Storage temperature

-20 °C to +60 °C (-4 °F to +140

°F)

Dimensions (approx.)

125 × 39 × 62 mm

(5 × 1 9/16 × 2 1/2 in.)

(w/h/d)

excluding projecting parts

Mass (approx.)

280 g (9.8 oz)

excluding power cord

Battery pack

Maximum output voltage

DC 8.4 V

Output voltage

DC 7.2 V

Capacity

5.0 Wh (700 mAh)

Operating temperature

0 °C to 40 °C (32 °F to 104 °F)

Dimensions (approx.)

38.4 × 20.6 × 70.8 mm

(1 9/16 × 13/16 × 2 7/8 in.)

(w/h/d)

Mass (approx.)

70 g (2.5 oz)

Type

Lithium ion

Design and specifications are subject to change without notice.

Identifying the parts and controls

Camcorder

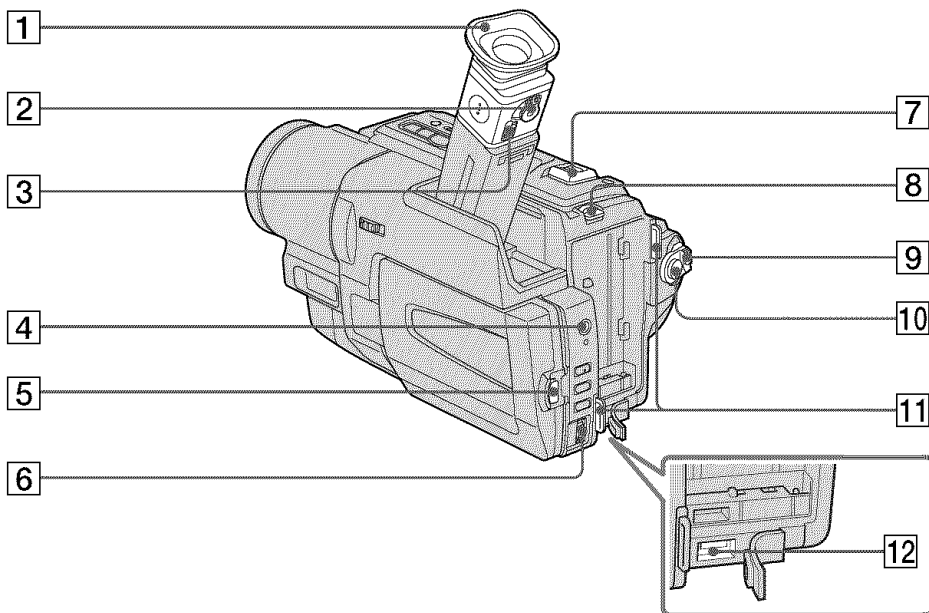

Quick Reference

- | | |
|---|---|
| 1 Eyecup | 6 SEL/PUSH EXEC dial (p. 36, 79) |
| 2 Viewfinder lens adjustment lever (p. 22) | 7 Power zoom lever (p. 21) |
| 3 Eyecup RELEASE knob (p. 98) | 8 BATT RELEASE lever (p. 11) |
| 4  (headphones) jack
When you use headphones, the speaker on your camcorder is silent. | 9 POWER switch (p. 18) |
| 5 OPEN button (p. 18) | 10 START/STOP button (p. 18) |
| | 11 Hooks for shoulder strap (p. 105) |
| | 12 DC IN jack (p. 12) |



This mark indicates that this product is a genuine accessory for Sony video products.

When purchasing Sony video products, Sony recommends that you purchase accessories with this "GENUINE VIDEO ACCESSORIES" mark.

Identifying the parts and controls

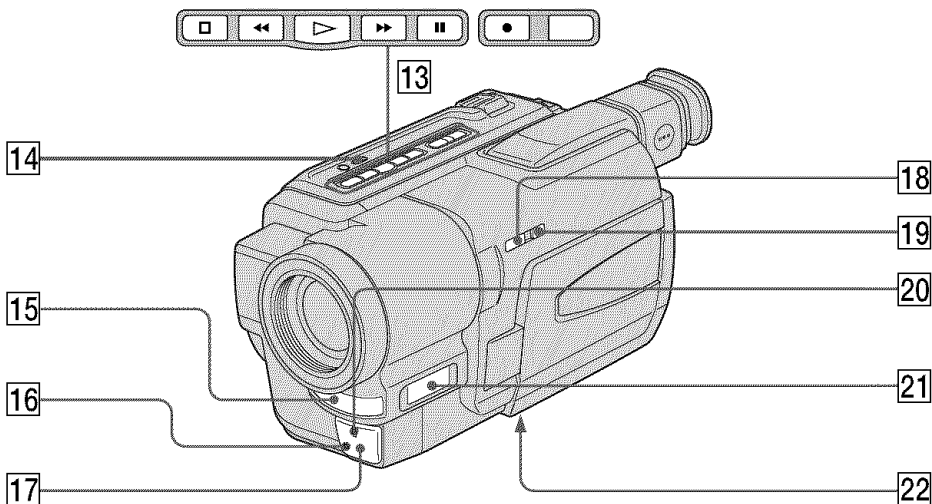

13 Video control buttons (p. 27, 30)

- STOP (stop)
- ◀ REW (rewind)
- ▶ PLAY (playback)
- ▶▶ FF (fastforward)
- || PAUSE (pause)
- REC (recording)

14 SUPER LASER LINK button (p. 32)

15 Microphone

16 Remote sensor

17 Infrared rays emitter (p. 24, 32)

18 NIGHTSHOT switch (p. 24)

19 SUPER NIGHTSHOT button (p. 25)

20 Camera recording lamp (p. 18)

21 Display window (p. 109)

22 Tripod receptacle (base)

Make sure that the length of the tripod screw is less than 6.5 mm (9/32 inch). Otherwise, you cannot attach the tripod securely and the screw may damage your camcorder.

Attaching the lens cap

Attach the lens cap to the grip strap as illustrated.

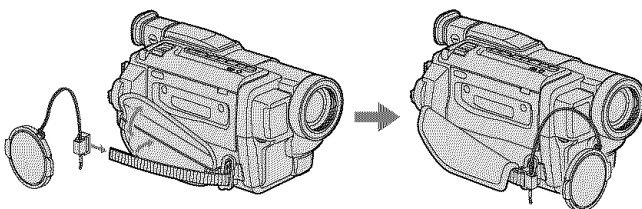

Identifying the parts and controls

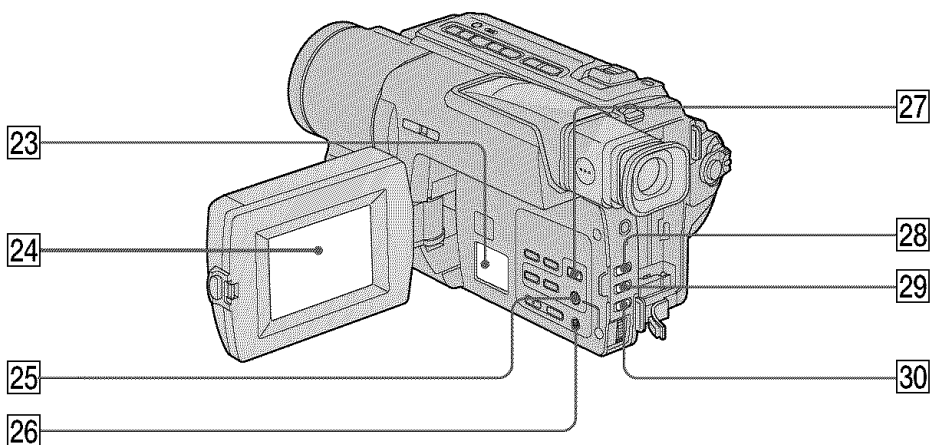

23 Speaker

24 LCD screen (p. 19)

25 MENU button (p. 36, 79)

26 RESET button (p. 88)

27 EXPOSURE button (p. 46)

28 FADER button (p. 38)

29 BACK LIGHT button (p. 24)

30 FOCUS button (p. 47)

Attaching the shoulder strap

Attach the shoulder strap supplied with your camcorder to the hooks for the shoulder strap.

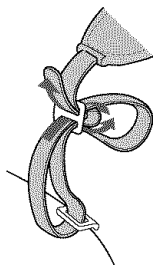

Identifying the parts and controls

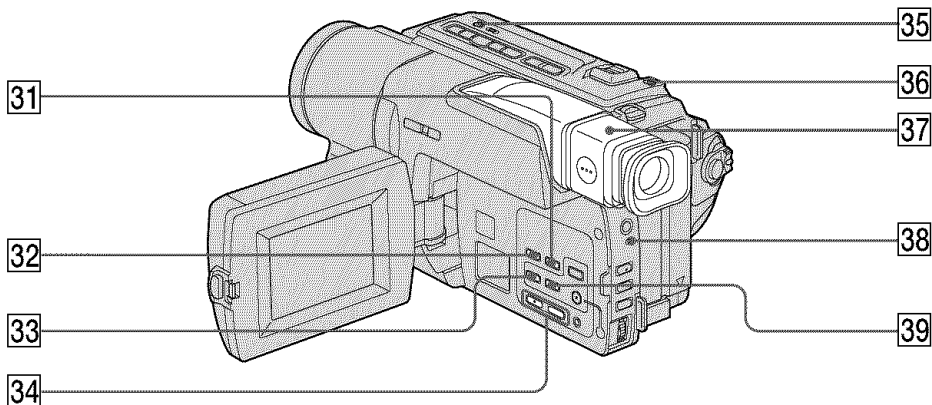

31 END SEARCH button (p. 26)

32 DISPLAY button (p. 28)

33 PB ZOOM button (p. 57)

34 VOLUME buttons (p. 27)

35 LIGHT button (p. 52)

36 PHOTO button (p. 34)

37 Viewfinder (p. 22)

38 CHG lamp (p. 12)

39 TITLE button (p. 48, 50)

Identifying the parts and controls

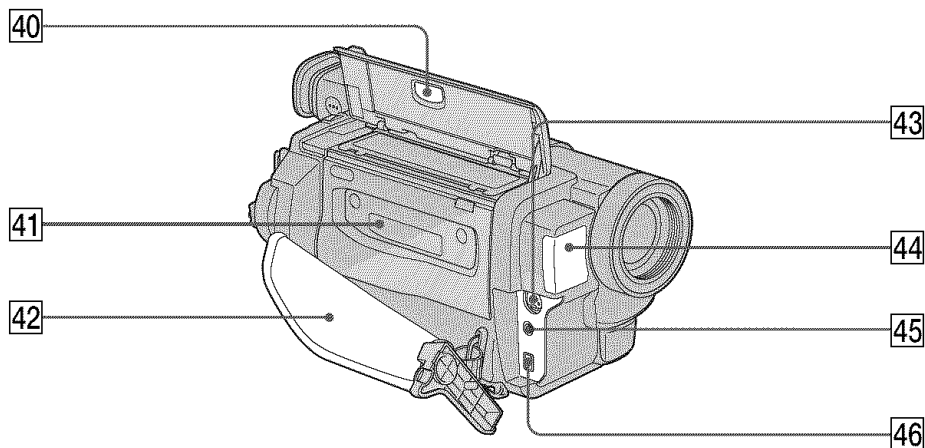

40 EJECT button (p. 17)



41 Cassette compartment (p. 17)

42 Grip strap

43 S VIDEO OUT jack (p. 31, 35, 63)

44 Built-in light (p. 52)

45 A/V OUT jack (p. 31, 35, 63)

46  DV IN/OUT jack (p. 64, 76)
The  DV IN/OUT jack is i.LINK compatible.

Fastening the grip strap

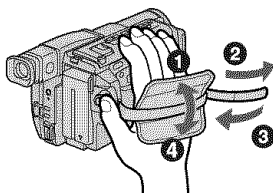

Fasten the grip strap firmly.

Identifying the parts and controls

Remote Commander

The buttons that have the same name on the Remote Commander as on your camcorder function identically to the buttons on your camcorder.

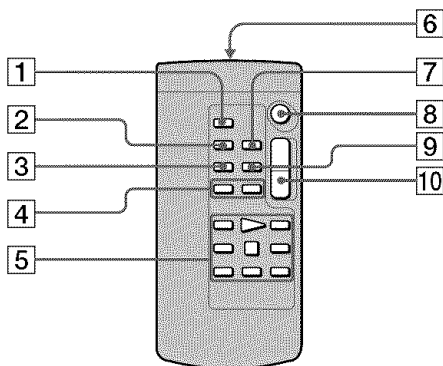

- | | |
|---|---|
| 1 PHOTO button (p. 34) | 7 ZERO SET MEMORY button (p. 58, 78) |
| 2 DISPLAY button (p. 28) | 8 START/STOP button (p. 18) |
| 3 SEARCH MODE button (p. 59, 61) | 9 DATA CODE button (p. 28) |
| 4 ◀◀/▶▶ buttons (p. 59, 61) | 10 Power zoom button (p. 21) |
| 5 Tape transport buttons (p. 30) | |
| 6 Transmitter | |

Point toward the remote sensor to control the camcorder after turning on the camcorder.

To prepare the Remote Commander

Insert 2 size AA (R6) batteries by matching the + and – polarities on the batteries to the + – marks inside the battery compartment.

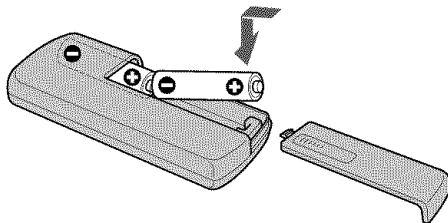

Notes on the Remote Commander

- Point the remote sensor away from strong light sources such as direct sunlight or overhead lighting. Otherwise, the Remote Commander may not function properly.
- Your camcorder works in the Commander mode VTR 2. Commander modes 1, 2 and 3 are used to distinguish your camcorder from other Sony VCRs to avoid remote control misoperation. If you use another Sony VCR in the Commander mode VTR 2, we recommend changing the Commander mode or covering the sensor of the VCR with black paper.

Identifying the parts and controls

Operation indicators

LCD screen and Viewfinder

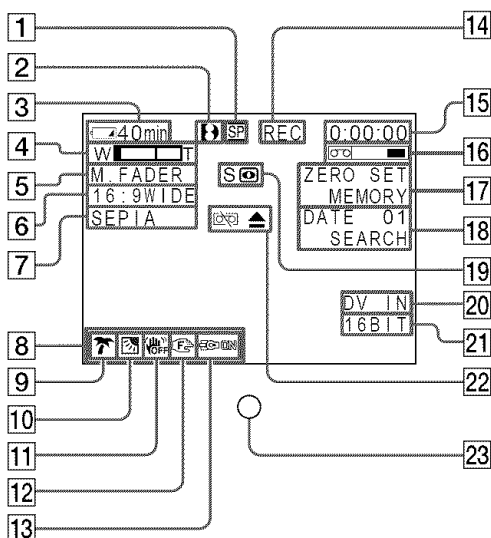

Display window



- 1 Recording mode indicator (p. 18) /Mirror mode indicator (p. 19)
- 2 Format indicator (p. 92)
- 3 Remaining battery time indicator (p. 23)
- 4 Zoom indicator (p. 21)/Exposure indicator (p. 46)
- 5 Fader indicator (p. 38)/Digital effect indicator (p. 42, 56)
- 6 Wide mode indicator (p. 36)
- 7 Picture effect indicator (p. 40, 55)
- 8 Volume indicator (p. 27)/ Data code indicator (p. 28)
- 9 PROGRAM AE indicator (p. 45)
- 10 Backlight indicator (p. 24)
- 11 SteadyShot off indicator (p. 80)
- 12 Manual focusing indicator (p. 47)
- 13 Built-in light indicator (p. 52)
- 14 STBY/REC indicator (p. 18)/Video control mode (p. 30)
- 15 Tape counter indicator (p. 23)/Time code indicator (p. 23)/Self-diagnosis display indicator (p. 89)/Tape photo recording indicator (p. 34)
- 16 Remaining tape indicator (p. 23)
- 17 ZERO SET MEMORY indicator (p. 58, 78)
- 18 Search mode indicator (p. 26, 59, 61)
- 19 NIGHTSHOT indicator (p. 24)/ SUPER NIGHTSHOT indicator (p. 25)
- 20 DV IN indicator (p. 76)
- 21 Audio mode indicator (p. 82)
- 22 Warning indicators (p. 90)
- 23 Camera recording lamp (p. 18)
This indicator appears in the viewfinder only.
- 24 Tape counter indicator (p. 23)/Time code indicator (p. 23)/Self-diagnosis display indicator (p. 89)

Index

A, B

AC power adaptor 12
Adjusting viewfinder 22
AFM HiFi Sound 92
AUDIO MIX 81
AUDIO MODE 82
A/V connecting cable
..... 31, 35, 63
BACK LIGHT 24
Battery pack 11
BEEP 84
BOUNCE 37

C, D

Charging battery 12
Charging the built-in
rechargeable lithium cell
..... 99
Clock set 16
Data code 28
Date search 59
DEMO 83
DIGITAL EFFECT 41, 56
Digital program editing 65
Digital 8 system 92
DISPLAY 28
DOT 37
Dual sound track tape 92
Dubbing a tape 63
DV connecting cable 64

E

END SEARCH 26, 30
Exposure 46

F, G, H

FADER 37
Fade in/out 37
FLASH MOTION 41
FOCUS 47
Grip strap 107
Headphone jack 103
Heads 98
HiFi SOUND 81

I, J, K, L

i.LINK 64, 94, 107
"InfoLITHIUM" battery 93
Infrared rays emitter 24, 32
LUMINANCEKEY 41

M, N

Main sound 81
Manual focus 47
Menu settings 79
Mirror mode 19
Moisture condensation 97
Monaural 31
MONOTONE 37
Mosaic fader 37
NIGHTSHOT 24
NTSC system 96

O, P, Q

OLD MOVIE 41
Operation indicators 109
OVERLAP 37
Photo scan 62
Photo search 61
PICTURE EFFECT 40, 55
Picture search 30
Playback pause 30
PROGRAM AE 44

R

Recording time 13
Remaining battery time
indicator 23
Remaining tape indicator ... 23
Remote Commander 108
Remote sensor 104
RESET 88

S

Self-diagnosis display 89
Shoulder strap 105
Skip scan 30
Slow playback 30
SLOW SHUTTER 41
STEADYSHOT 80
Stereo tape 92
STILL 41
Sub sound 81
SUPER LASER LINK 32
SUPER NIGHTSHOT 25
S VIDEO OUT jack .. 31, 35, 63

T, U, V

Tape counter indicator 23
Tape PB ZOOM 57
Tape photo recording 34
Telephoto 21
Time code 23
Title 48
TRAIL 41
Transition 19
TV color systems 96

W, X, Y, Z

Warning indicators 90
Wide-angle 21
Wide mode 36
WIPE 37
WORLD TIME 84
Write-protect tab 17
Zero set memory 58, 78
Zoom 21

Sony **on** line

<http://www.world.sony.com/>

Printed on recycled paper

Sony Corporation Printed in Japan

