

Gas Water Heater with the Flame Lock™ Safety System Installation Instructions and Use & Care Guide

To obtain technical, warranty, or service assistance during or after the installation of this water heater, call toll free:

1-877-817-6750

When calling for assistance, please have the following information ready:

1. Model number
2. 7 Digit product number
3. Serial number
4. Date of installation

Table of Contents	2
-------------------------	---

WARNING: If the information in these instructions is not followed exactly, a fire or explosion may result causing property damage, personal injury or death.

Do not store or use gasoline or other flammable vapors and liquids in the vicinity of this or any other appliance.

WHAT TO DO IF YOU SMELL GAS

- Do not try to light any appliance.
- Do not touch any electrical switch; do not use any phone in your building.
- Immediately call your gas supplier from a neighbor's phone. Follow the gas supplier's instructions.
- If you cannot reach your gas supplier, call the fire department.

Installation and service must be performed by a qualified installer, service agency or the gas supplier.



Your safety and the safety of others are very important.

We have provided many important safety messages in this manual and on your appliance. Always read and obey all safety messages.



This is the safety alert symbol.

This symbol alerts you to potential hazards that can kill or hurt you and others.

All safety messages will follow the safety alert symbol and either the word "DANGER" or "WARNING." These words mean:

! DANGER

You can be killed or seriously injured if you don't immediately follow instructions.

! WARNING

You can be killed or seriously injured if you don't follow instructions.

All safety messages will tell you what the potential hazard is, tell you how to reduce the chance of injury, and tell you what can happen if the instructions are not followed.

Important Instructions

- Do not use this appliance if any part has been under water. Immediately call a qualified service technician. Water heaters subjected to flood conditions or anytime the gas controls, main burner or pilot have been submerged in water require replacement of the entire water heater.
- Hydrogen gas can be produced in a hot water system that has not been used for a long period of time (generally two weeks or more). Hydrogen gas is extremely flammable and can ignite when exposed to a spark or flame. To prevent the possibility of injury under these conditions, we recommend the hot water faucet be opened for several minutes at the kitchen sink before using any electrical appliance which is connected to the hot water system. If hydrogen is present, there will probably be an unusual sound such as air escaping through the faucet as water begins to flow. Do not smoke or have any open flame near the faucet at the time it is open.

The California Safe Drinking Water and Toxic Enforcement Act requires the Governor of California to publish a list of substances known to the State of California to cause cancer, birth defects, or other reproductive harm, and requires businesses to warn of potential exposure to such substances.

Warning: This product contains a chemical known to the State of California to cause cancer, birth defects, or other reproductive harm.

This appliance can cause low-level exposure to some of the substances listed, including formaldehyde, carbon monoxide, and soot.

Table Of Contents

	PAGE
Water Heater Safety	1-2
Installing Your Gas Water Heater	3-16
Unpacking the Water Heater	3
Location Requirements	4
Gas Supply	6
Combustion Air Supply and Ventilation	7
Water System Piping	12
Installation Checklist	16
Operating Your Water Heater	17-19
Lighting Instructions	17
Operational Conditions	19
Maintenance of Your Water Heater	20-24
Trouble Shooting Chart	25-26
Repair Parts Illustration	27-28

INSTALLING YOUR GAS WATER HEATER

Consumer Information

This water heater is design-certified by CSA International as a Category I, non-direct vented water heater which takes its combustion air either from the installation area or from air ducted to the unit from the outside.

This water heater must be installed according to all local and state codes or in the absence of local and state codes with the "National Fuel Gas Code", ANSI Z223.1(NFPA 54)- latest edition. This is available from the following:

American Gas Association
1515 Wilson Boulevard
Arlington, VA 22209

National Fire Protection Agency
1 Batterymarch Park
Quincy, MA 02269

Check your phone listings for the local authorities having jurisdiction over your installation.

Consumer Responsibilities

This manual has been prepared to acquaint you with the installation, operation and maintenance of your gas water heater and provide important safety information in these areas.

Read all of the instructions thoroughly before attempting the installation or operation of this water heater. Keep this manual for future reference.

Service to the Flame Lock™ **safety system** should only be performed by a qualified service technician.

The manufacturer of this water heater will not be liable for any damages caused by failure to comply with the installation and operating instructions outlined in this manual.

If you lack the necessary skills required to properly install this water heater or you have difficulty following the instructions, you should not proceed but have a qualified person perform the installation of this water heater. Massachusetts code requires this water heater to be installed in accordance with Massachusetts Plumbing and Fuel Gas Code 248 CMR section 2.00 and 5.00.

A data plate identifying your water heater can be found next to the gas control valve/thermostat. When referring to your water heater always have the information listed on the data plate readily available.

Unpacking the Water Heater

WARNING

Excessive Weight Hazard
Use two or more people to move and install water heater.
Failure to do so can result in back or other injury.

Removing Packaging Materials

Important: Do not remove any permanent instructions, labels, or the data label from outside of the water heater or on the inside of panels.

- Remove exterior packaging and place installation components aside.
- Inspect all parts for damage prior to installation and start-up.
- Completely read all instructions before attempting to assemble and install this product.
- After installation, dispose of packaging material in the proper manner.

⚠️ WARNING



⚠️ Vapors from flammable liquids will explode and catch fire causing death or severe burns.

Do not use or store flammable products such as gasoline, solvents or adhesives in the same room or area near the water heater.

Keep flammable products:

- 1. far away from heater**
- 2. in approved containers,**
- 3. tightly closed and**
- 4. out of children's reach.**

Water heater has a main burner and pilot flame. The pilot flame:

- 1. is on all the time and**
- 2. will ignite flammable vapors.**

Vapors:

- 1. cannot be seen,**
- 2. are heavier than air,**
- 3. go a long way on the floor and**
- 4. can be carried from other rooms to the pilot flame by air currents.**

Do not install this water where flammable products will be stored.

Location Requirements

⚠️ WARNING

**Carbon Dioxide Poisoning Hazard
Do not install in a mobile home.
Doing so can result in death or carbon monoxide poisoning.**

The Flame Lock™ safety system is designed to reduce the risk of flammable vapor related fires. The patented system protects your family by trapping the burning vapors within the water heater combustion chamber through the special flame-trap. The burning vapors literally "burn themselves out" without escaping back into the room. In the event of a flammable vapor incident, the Flame Lock™ safety system shuts off the gas supply to the water heater's burner and pilot preventing re-ignition of any remaining flammable vapors in the area. This will permanently disable the water heater.

Although this water heater is equipped with the Flame Lock™ safety system, areas where flammable liquids (gasoline, solvents, liquid propane, butane, etc.) or other substances which emit flammable vapors are stored are not suitable for water heater installation. Never store or use flammable substances in the same room or area containing a gas water heater. If such flammables must be used, all gas burning appliances in the vicinity must be shut off and their pilot lights extinguished. Open the doors and windows for ventilation while flammable substances are in use.

If flammable liquids or vapors have spilled or leaked in the area of the water heater, leave the area immediately and call the fire department from a neighbor's home. Do not attempt to clean the spill until all ignition sources have been extinguished.

Site Location

- Select a location near the center of the water piping system. The water heater must be installed indoors and in a vertical position on a level surface.
- Locate the water heater as close to the chimney or gas vent as practical. Consider the vent system piping and combustion air supply requirements when selecting the water heater location. The venting system must be able to run from the water heater to termination with minimal length and elbows.
- Locate the water heater near the existing gas piping. If installing a new gas line, locate the water heater to minimize the pipe length and elbows.

Note: The water heater must be installed according to all local and state codes or in absence of the local and state codes with the "National Fuel Gas Code", ANSI Z223.1 (NFPA 54)-latest edition.

Important: The water heater should be located in an area where leakage of the tank or connections will not result in damage to the area adjacent to the water heater or to lower floors of the structure. Due to the normal corrosive action of the water, the tank will eventually leak after an extended period of time. A suitable metal drain pan should be installed under the water heater as shown below, to help protect the property from damage which may occur from condensate formation or leaks in the piping connections or tank. The pan must limit the water level to a maximum depth of 1 3/4 inches and be two inches wider than the heater and piped to an adequate drain. The pan must not restrict combustion air flow. Locate the water heater near a suitable indoor drain. Outside drains are subject to freezing temperatures which can obstruct the drain line. The piping should be at least 3/4" ID and pitched for proper drainage. Under no circumstances will the manufacturer be held liable for any water damage in connection with this water heater.

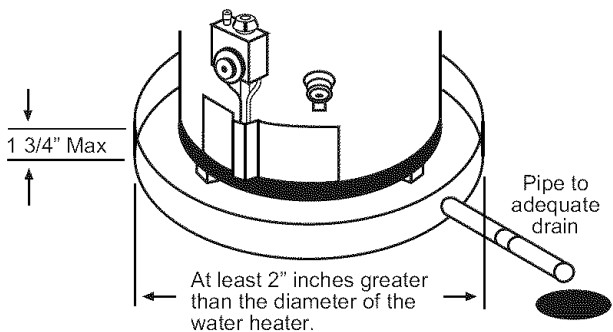

- The water heater should be located in an area not subject to freezing temperatures. Water heaters located in unconditioned spaces (i.e., attics, basements, etc.) may require insulation of the water piping and drain piping to protect against freezing. The drain and controls must be easily accessible for operation and service. Maintain proper clearances as specified on the data plate.
- Do not locate the water heater near an air-moving device. The operation of air-moving devices such as exhaust fans, ventilation systems, clothes dryers, fire-places, etc., can affect the proper operation of the water heater. Special attention must be given to conditions these devices may create. Flow reversal of flue gases may cause an increase of carbon monoxide inside of the dwelling.

Figure 1
Air Moving
Devices

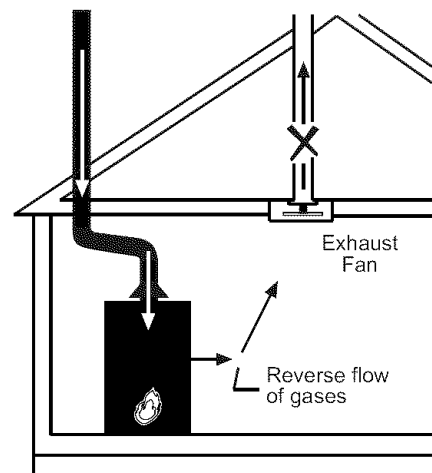

Clearances and Accessibility

Notice: Minimum clearances from combustible materials are stated on the data plate adjacent to the thermostat of the water heater.

- The water heater is certified for installation on a combustible floor.

Important: If installing over carpeting, the carpeting must be protected by a metal or wood panel beneath the water heater. The protective panel must extend beyond the full width and depth of the water heater by at least 3 inches (76.2mm) in any direction or if in a alcove or closet installation, the entire floor must be covered by the panel.

Figure 2 may be used as a reference guide to locate the specific clearance locations. A minimum of 24 inches of front clearance should be provided for inspection and service.

Figure 2
Minimum Clearance
Locations

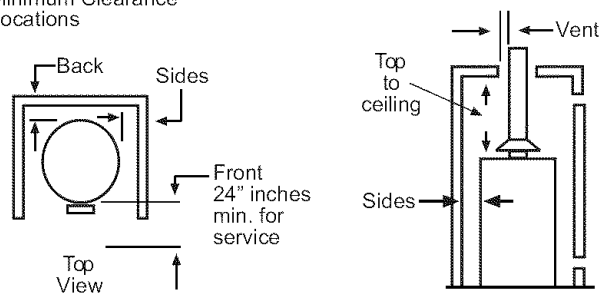

State of California

Note: The water heater must be braced, anchored, or strapped to avoid moving during an earthquake. Contact local utilities for code requirements in your area or call **1-877-817-6750** and request instructions.

Gas Supply

⚠ WARNING



Explosion Hazard

Use a new AGA or CSA approved gas supply line.

Install a shut-off valve.

Do not connect a natural gas water heater to a L.P. Gas Supply.

Failure to follow these instructions can result in death, explosion, or carbon monoxide poisoning.

OBSERVE ALL GOVERNING CODES AND ORDINANCES.

Gas Requirements

Read the data plate to be sure the water heater is made for the type of gas you will be using in your home. This information will be found on the data plate located near the gas control valve. If the information does not agree with the type of gas available, do not install or light. Call your dealer.

Note: An odorant is added by the gas supplier to the gas used by this water heater. This odorant may fade over an extended period of time. Do not depend upon this odorant as an indication of leaking gas.

Gas Piping

The gas piping must be installed according to all local and state codes or in absence of local and state codes with the "National Fuel Gas Code", ANSI Z223.1 (NFPA54)-latest edition.

Tables 1 and 2 on page 7 are provided as a sizing reference for commonly used gas pipe materials. Consult the "National Fuel Gas Code" for the recommended gas pipe size of other materials.

Refer To Figure 3

Note: When installing gas piping, apply approved pipe joint compound.

1. Install a readily accessible manual shut-off valve in the gas supply line as recommended by the local utility. Know the location of this valve and how to turn off the gas to this unit.
2. Install a drip leg (if not already incorporated as part of the water heater) as shown. The drip leg must be no less than 3 inches long for the accumulation of dirt, foreign material and water droplets.
3. Install a ground joint union between the gas valve/thermostat and the manual shut-off valve. This is to allow easy removal of the gas valve/thermostat.
4. Turn the gas supply on and check for leaks. Use a chloride-free soap and water solution (bubbles forming indicate a leak) or other approved method.

6

Figure 3
Gas Piping

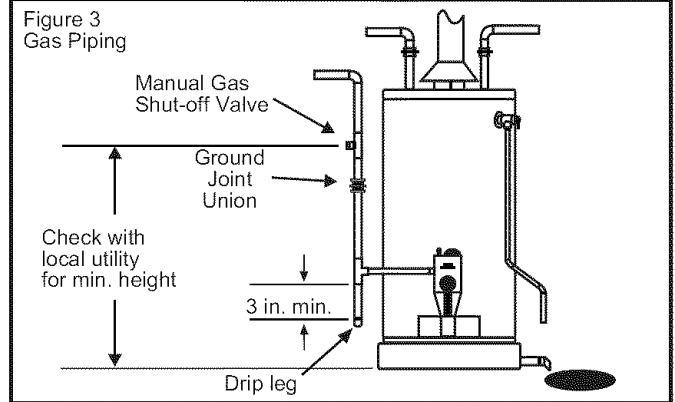

Gas Pressure

Important: The gas supply pressure must not exceed the maximum supply pressure as stated on the water heater's data plate. The minimum supply pressure is for the purpose of input adjustment.

Gas Pressure Testing

Important: This water heater and its gas connection must be leak tested before placing the appliance in operation.

- If the code requires the gas lines to be tested at a pressure exceeding 14" W.C., the water heater and its manual shut-off valve must be disconnected from the gas supply piping system and the line capped.
- If the gas lines are to be tested at a pressure less than 14" W.C., the water heater must be isolated from the gas supply piping system by closing its manual shut-off valve.

U.L. recognized fuel gas and carbon monoxide (CO) detectors are recommended in all applications and should be installed using the manufacturer's instructions and local codes, rules, or regulations.

Note: Air may be present in the gas lines and could prevent the pilot from lighting on initial start-up. The gas lines should be purged of air by a qualified service technician after installation of the gas piping system.

LP Gas

⚠ WARNING



Explosion Hazard

Have a qualified person make sure L.P. gas pressure does not exceed 13" water column.

Examples of a qualified person include licensed heating personnel, authorized gas company personnel, and authorized service personnel.

Failure to do so can result in death, explosion, or fire.

Table 1
Natural Gas Pipe Capacity Table (Cu. Ft./hr)
 Capacity of gas pipe of different diameters and lengths in cu. ft. per hr. with pressure drop of 0.3 in. and specific gravity of 0.60 (natural gas).

Nominal Iron Pipe Size, in.	Length of Pipe, Feet													
	10	20	30	40	50	60	70	80	90	100	125	150	175	200
1/2	132	92	73	63	56	50	46	43	40	38	34	31	28	26
3/4	278	190	152	130	115	105	96	90	84	79	72	64	59	55
1	520	350	285	245	215	195	180	170	160	150	130	120	110	100
1-1/4	1050	730	590	500	440	400	370	350	320	305	275	250	225	210
1-1/2	1600	1100	890	760	670	610	560	530	490	460	410	380	350	320

After the length of pipe has been determined, select the pipe size which will provide the minimum cubic feet per hour required for the gas input rating of the water heater. By formula:

$$\text{Cu. Ft. Per Hr. Required} = \frac{\text{Gas Input of Water Heater (BTU/HR)}}{\text{Heating Value of Gas (BTU/FT}^3\text{)}}$$

The gas input of the water heater is marked on the water heater data plate. The heating value of the gas (BTU/FT³) may be determined by consulting the local natural gas utility.

Table 2
LP Gas Capacity Table
 Maximum capacity of pipe in thousands of BTU per hour of undiluted liquefied petroleum gases (at 11 inches water column pressure). Based on a Pressure Drop of 0.5 Inch Water Column.

Nominal Iron Pipe Size, in.	Length of Pipe, Feet												
	10	20	30	40	50	60	70	80	90	100	125	150	
1/2	275	189	152	129	114	103	96	89	83	78	69	63	
3/4	576	393	315	267	237	217	196	185	173	162	146	132	
1	1071	732	590	504	448	409	378	346	322	307	275	252	
1-1/4	2205	1496	1212	1039	913	834	771	724	677	630	567	511	

Example: Input BTU requirement of the water heater 100,000 BTUH
 Total pipe length, 80 feet = 3/4" IPS required.

Additional tables are available in the latest edition of the "National Fuel Gas Code", ANSI Z223.1

Combustion Air Supply and Ventilation

⚠️ WARNING

Carbon Monoxide Warning

Follow all the local and state codes or in absence of local and state codes the "National Fuel Gas Code", ANSI Z223.1 (NFPA 54)- latest edition to properly install vent system.

Failure to do so can result in death, explosion, or carbon monoxide poisoning.

Important: Air for combustion and ventilation must not come from a corrosive atmosphere. Any failure due to corrosive elements in the atmosphere is excluded from warranty coverage.

The following types of installation (but not limited to the following) will require outdoor air for combustion due to chemical exposure and may reduce but not eliminate the presence of corrosive chemicals in the air:

- Beauty shops
- Photo processing labs
- Buildings with indoor pools

- Water heaters installed in laundry, hobby or craft rooms.
- Water heaters installed near chemical storage areas.

Combustion air must be free of acid-forming chemicals such as sulfur, fluorine, and chlorine. These elements are found in aerosol sprays, detergents, bleaches, cleaning solvents, air fresheners, paint and varnish removers, refrigerants, and many other commercial and household products. When burned, vapors from these products form highly corrosive acid compounds. These products should not be stored or used near the water heater or air inlet.

Combustion and ventilation air requirements are determined by the location of the water heater. The water heater may be located in either an open (unconfined) area or in a confined area or small enclosure such as a closet or small room. Confined spaces are areas with less than 50 cubic feet for each 1,000 BTUH of the total input for all gas-using appliances.

Unconfined Space

A water heater in an unconfined space uses indoor air for combustion and requires at least 50 cubic feet for each 1,000 BTUH of the total input for all gas appliances. The table below shows a few examples of the minimum square footage (area) required for various BTUH inputs.

BTUH Input	Min. Sq. Feet with 8' Ceiling	Typical Room with 8' Ceiling
30,000	188	9 x 21
45,000	281	14 x 20
60,000	375	15 x 25
75,000	469	15 x 31
90,000	563	20 x 28
105,000	657	20 x 33
120,000	750	25 x 30
135,000	844	28 x 30

Important:

- The area must be open and be able to provide the proper air requirements to the water heater. Areas that are being used for storage or contain large objects may not be suitable for water heater installation.
- Water heaters installed in open spaces in buildings with unusually tight construction may still require outdoor air to function properly. In this situation, outside air openings should be sized the same as for a confined space.
- Modern home construction usually requires supplying outside air into the water heater area.

Confined Space

For the correct and proper operation of this water heater, ample air must be supplied for the combustion, ventilation and dilution of flue gases. Small enclosures and confined areas must have two permanent openings so that sufficient fresh air can be drawn from outside of the enclosure. One opening shall be within 12 inches of the top and one within 12 inches of the bottom of the enclosure as shown in Figure 4.

The size of each opening (free area) is determined by the total BTUH input of all gas utilization equipment (i.e., water heaters, furnaces, clothes dryers, etc.) and the method by which the air is provided. The BTUH input can be found on the water heater data plate. Additional air can be provided by two methods:

1. All Air from Inside the Building.
2. All Air from Outdoors.

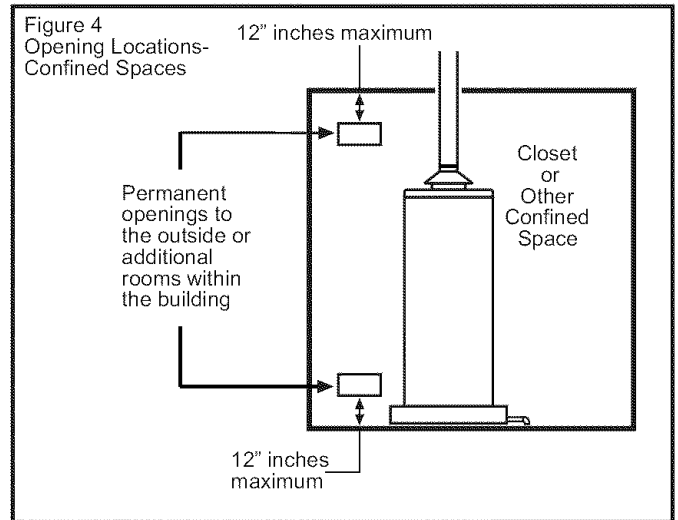

All Air from Inside the Building

When additional air is to be provided to the confined area from additional room(s) within the building, the total volume of the room(s) must be of sufficient size to properly provide the necessary amount of fresh air to the water heater and other gas utilization equipment in the area. If you are unsure that the structure meets this requirement, contact your local gas utility company or other qualified agency for a safety inspection.

Each of the two openings shall have a minimum free area of 1 square inch per 1,000 BTUH of the total input rating of all gas utilization equipment in the confined area, but not less than 100 square inches (Figure 5).

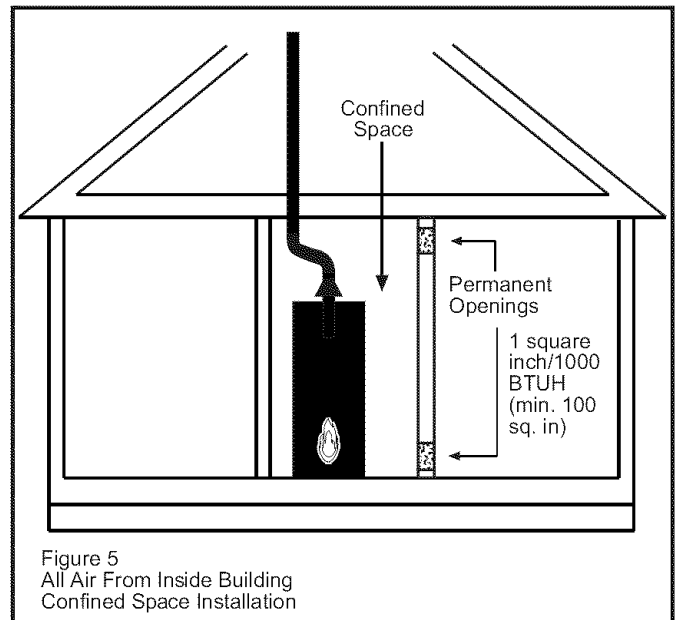

Figure 5
All Air From Inside Building
Confined Space Installation

All Air from Outdoors

Outdoor fresh air can be provided to a confined area either directly or by the use of vertical and horizontal ducts. The fresh air can be taken from the outdoors or from crawl or attic spaces that freely communicate with the outdoors. Attic or crawl spaces cannot be closed and must be properly ventilated to the outside.

Ductwork must be of the same cross-sectional area as the free area of the opening to which they connect. The minimum dimension of rectangular air ducts cannot be less than 3 inches.

The size of each of the two openings is determined by the method in which the air is to be provided. Refer to Table 4 to calculate the minimum free area for each opening. Figures 6, 7, and 8 are typical examples of each method.

Louvers and Grilles

In calculating free area for ventilation and combustion air supply openings, consideration must be given to the blocking effect of protection louvers, grilles, and screens. These devices can reduce airflow, which in turn may require larger openings to achieve the required minimum free area. Screens must not be smaller than 1/4-inch mesh. If the free area through a particular design of louver or grille is known, it should be used in calculating the specified free area of the opening. If the design and free area are not known, it can be assumed that most wood louvers will allow 20 - 25% of free area while metal louvers and grilles will allow 60 - 75% of free area.

Louvers and grilles must be locked open or interconnected with the equipment so that they are opened automatically during equipment operation.

Keep louvers and grilles clean and free of debris or other obstructions.

Table 4		
Minimum Free Area of Permanent Openings for Ventilation and Combustion Air Supply - All Air from Outdoor Only.		
Based on the total BTUH input rating for all gas utilizing equipment within the confined space.		
Opening Source	Minimum Free Area Per Opening (sq. in.)	Reference Drawing
* Direct to outdoors	1 Square inch per 4000 BTUH	Figure 6
Vertical ducts	1 Square inch per 4000 BTUH	Figure 7
Horizontal ducts	1 Square inch per 2000 BTUH	Figure 8
Example: A water heater with an input rate of 50,000 BTUH using horizontal ducts would require each opening to have a minimum free area of 25 square inches. Minimum Free area = 50,000 BTUH x 1 sq. in. / 2000 BTUH = 25 Sq. Inches.		

* These openings connect directly with the outdoors through a ventilated attic, a ventilated crawl space, or through an outside wall.

Consult the local codes of your area for specific ventilation and combustion air requirements.

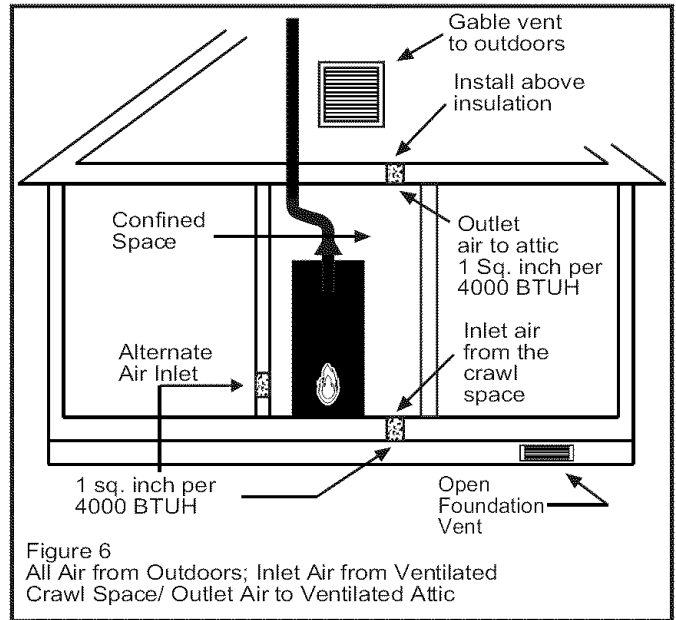

Figure 6
All Air from Outdoors; Inlet Air from Ventilated Crawl Space/ Outlet Air to Ventilating Attic

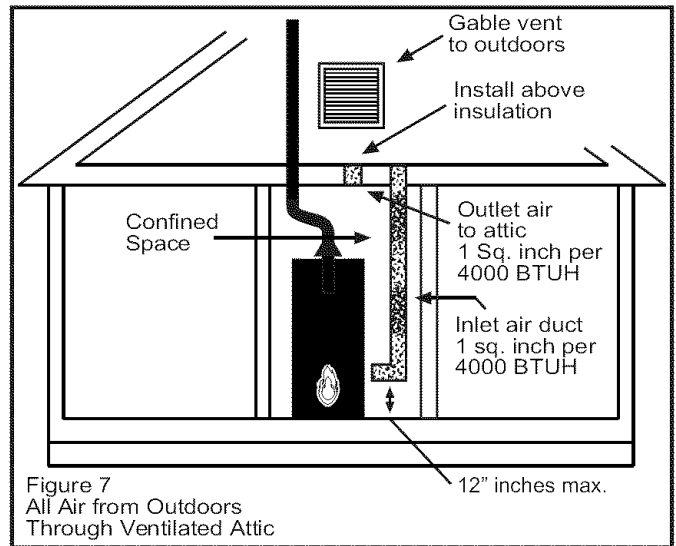

Figure 7
All Air from Outdoors Through Ventilating Attic

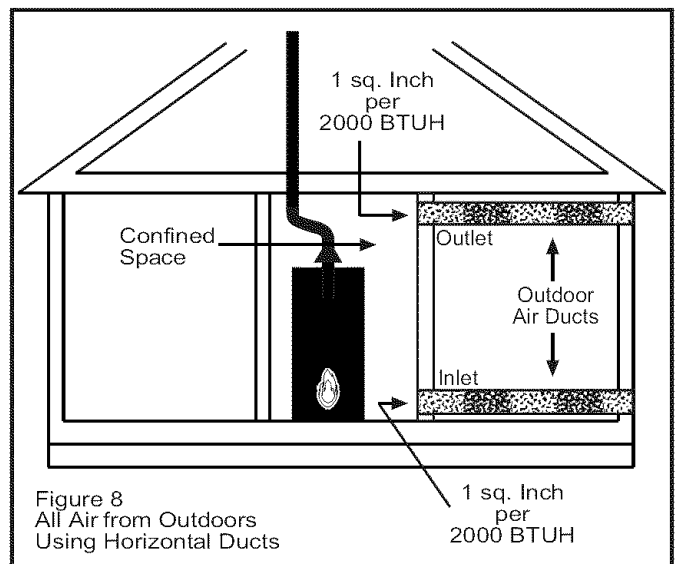

Figure 8
All Air from Outdoors Using Horizontal Ducts

Vent Pipe System

This water heater uses a non-direct, single-pipe vent system to remove exhaust gases created by the burning of fossil fuels. Air for combustion is taken from the immediate water heater location or is ducted in from the outside (see "Combustion Air Supply and Ventilation").

This water heater must be properly vented for the removal of exhaust gases to the outside atmosphere. Correct installation of the vent pipe system is mandatory for the proper and efficient operation of this water heater and is an important factor in the life of the unit.

The vent pipe must be installed according to all local and state codes or in absence of local and state codes with the "National Fuel Gas Code", ANSI Z223.1 (NFPA54)-latest edition. The vent pipe installation must not be obstructed so as to prevent the removal of exhaust gases to the outside atmosphere.

U.L. recognized fuel gas and carbon monoxide (CO) detectors are recommended in all applications and should be installed using the manufacturer's instructions and local codes, rules, or regulations.

Important: If you lack the necessary skills required to properly install this venting system, you should not proceed, but get help from a qualified installation technician.

Drafthood Installation

Align the legs of the draft hood with the slots provided. Insert the legs and secure the draft hood to the water heater's top with the four screws provided as shown in Figure 9. Do not alter the draft hood in any way. If you are replacing an existing water heater be sure to use the new draft hood supplied with the water heater.

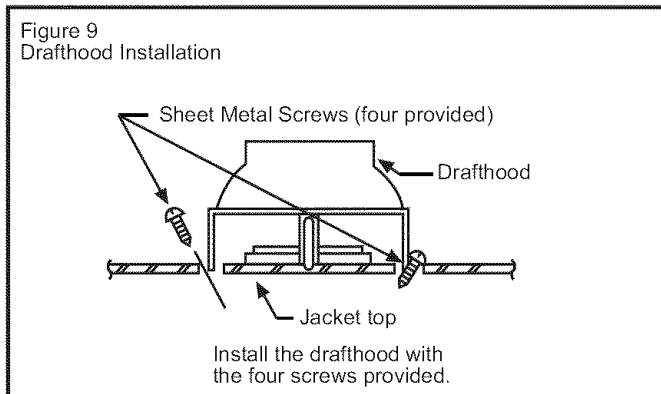

Vent Pipe Size

The vent pipe must be installed according to all local and state codes or in absence of local and state codes with the "National Fuel Gas Code", ANSI Z223.1 (NFPA54)-latest edition. It is important that you follow the guidelines in these instructions for sizing a vent pipe system. If a transition to a larger vent size is required, the vent transition connection must be made at the drafthood outlet.

Vent Connectors

1. Type B, Double Wall, U.L. Listed Vent Pipe.
2. Single Wall Vent Pipe.

Maintain the manufacturer's specified minimum clearance from combustible materials when using type B doublewall vent pipe.

Vent connectors made of type B, double wall vent pipe material may pass through walls or partitions constructed of combustible material if the minimum listed clearance is maintained.

Maintain a 6 inch minimum clearance from all combustible materials when using single wall vent pipe.

Important: Single wall vent pipe cannot be used for water heaters located in attics and may not pass through attic spaces, crawl spaces or any confined or inaccessible location. A single wall metal vent connector cannot pass through any interior wall.

When installing a vent connector, please note the following:

- Install the vent connector avoiding unnecessary bends, which create resistance to the flow of vent gases.
- Install without dips or sags with an upward slope of at least 1/4-inch per foot.
- Joints must be fastened by sheet metal screws or other approved means. It must be supported to maintain clearances and prevent separation of joints and damage.
- The length of the vent connector cannot exceed 75% of the vertical vent height.
- The vent connector must be accessible for cleaning, inspection and replacement.
- Vent connectors cannot pass through any ceiling, floor, fire wall, or fire partition.

Important: Existing vent systems must be inspected for obstructions, corrosion and proper installation.

Chimney Connection

Important: Before connecting a vent to a chimney, make sure the chimney passageway is clear and free of obstructions. The chimney must be cleaned if previously used for venting solid fuel appliances or fireplaces.

- The connector must be installed above the extreme bottom of the chimney to prevent potential stoppage of the flue gases.
- The connector must be firmly attached and sealed to prevent it from falling out.
- To aid in removing the connector, a thimble or slip joint may be used.
- The connector must not extend beyond the inner edge of the chimney as it may restrict the space between it and the opposite wall of the chimney (Figure 10).

Do not terminate the vent connector in a chimney that has not been certified for this purpose. Some local codes may prohibit the termination of vent connectors in a masonry chimney.

Vertical Exhaust Gas Vent

Vertical exhaust gas vents must be installed with UL listed type B vent pipe according to the vent manufacturer's instructions and the terms of its listing.

It must be connected to the water heater's draft hood by a certified vent connector or by directly originating at the draft hood opening.

Vertical gas vents must terminate with a listed cap or other roof assembly and be installed according to their manufacturer's instructions.

Gas vents must be supported to prevent damage, joint separation, and maintain clearances to combustible materials (Figures 11 and 12).

Important: This gas vent must be terminated in a vertical position to facilitate the removal of the burnt gases.

An unused chimney flue or masonry enclosure may be used as a passageway for the installation of a gas vent (Figure 12).

Common (combined) venting is allowable with vertical type B vent systems and lined masonry chimneys. The vent pipe must be installed according to all local and state codes or in absence of local and state codes with the "National Fuel Gas Code", ANSI Z223.1 (NFPA 54)-latest edition.

Figures 10-12 are examples of vent pipe system installations and may or may not be typical for your specific application. Consult the "National Fuel Gas Code", NFPA 54, ANSI Z223.1-latest edition and the guidelines set forth by prevailing local codes.

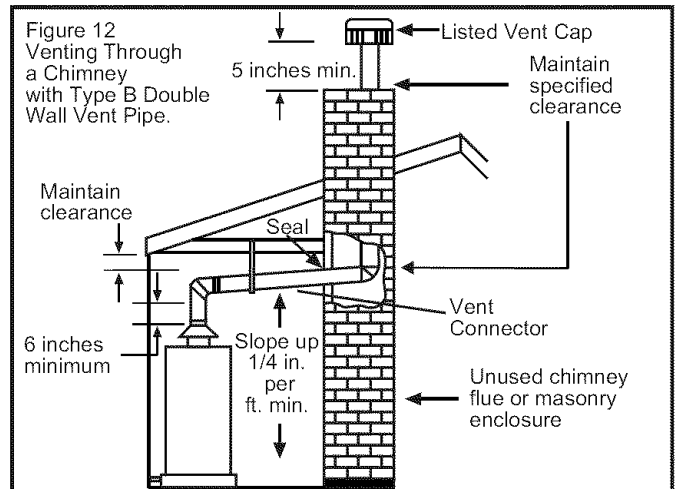
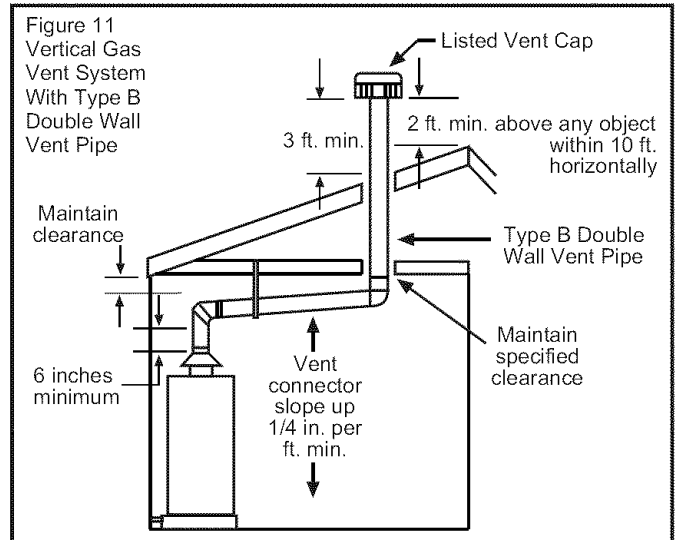
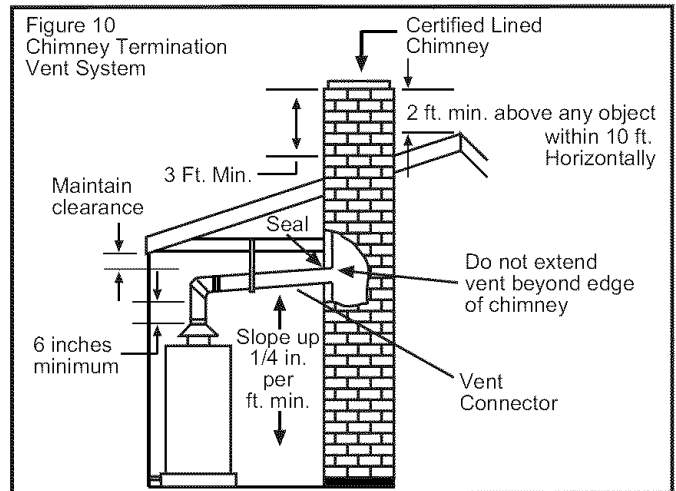

Water System Piping

Piping Installation

Piping, fittings, and valves should be installed according to the installation drawing (Figure 13). If the indoor installation area is subject to freezing temperatures, the water piping must be protected by insulation.

Water supply pressure should not exceed 80% of the working pressure of the water heater. The working pressure is stated on the water heater's data plate. If this occurs a pressure limiting valve with a bypass may need to be installed in the cold water inlet line. This should be placed on the supply to the entire house in order to maintain equal hot and cold water pressures.

Important: Heat cannot be applied to the water fittings on the heater as they may contain nonmetallic parts. If solder connections are used, solder the pipe to the adapter before attaching the adapter to the hot and cold water fittings.

Important: Always use a good grade of joint compound and be certain that all fittings are drawn up tight.

1. Install the water piping and fittings as shown in Figure 13. Connect the cold water supply (3/4" NPT) to the fitting marked "C". Connect the hot water supply (3/4" NPT) to the fitting marked "H".

Important: Some models may contain energy saving heat traps to prevent the circulation of hot water within the pipes. Do not remove the inserts within the heat traps.

2. The installation of unions in both the hot and cold water supply lines is recommended for ease of removing the water heater for service or replacement.
3. The manufacturer of this water heater recommends installing a tempering valve or an anti-scald device in the domestic hot water line as shown in Figure 14. These valves reduce the point of use temperature of the water by mixing cold and hot water and are readily available for use. Contact a licensed plumber or the local plumbing authority.
4. If installing the water heater in a closed water system, install a relief valve or expansion tank in the cold water line as specified under "Closed System/Thermal Expansion" (Page 13).
5. Install a shut-off valve in the cold water inlet line. It should be located close to the water heater and be easily accessible. Know the location of this valve and how to shut off the water to the heater.
6. Install a temperature and pressure relief valve in the opening marked "Temperature and Pressure(T & P) Relief Valve" on the water heater. Add a discharge line to the opening of the T & P relief valve. Follow the instructions under "Temperature and Pressure Relief Valve" (Page 14).

7. After piping has been properly connected to the water heater, remove the aerator at the nearest hot water faucet. Open the hot water faucet and allow the tank to completely fill with water. To purge the lines of any excess air, keep the hot water faucet open for 3 minutes after a constant flow of water is obtained. Close the faucet and check all connections for leaks.

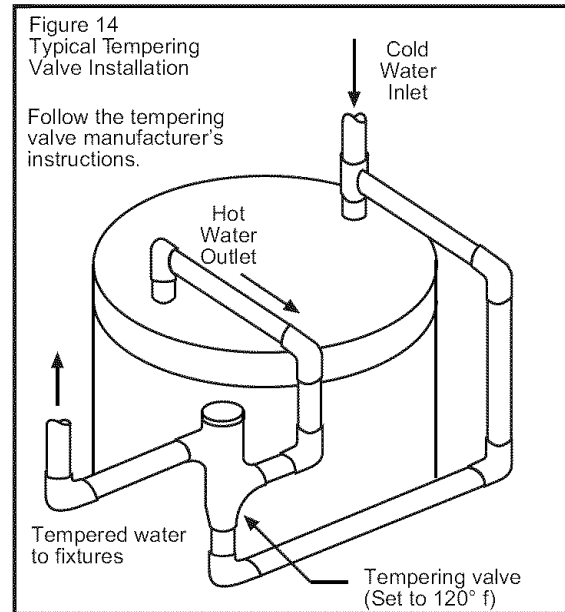
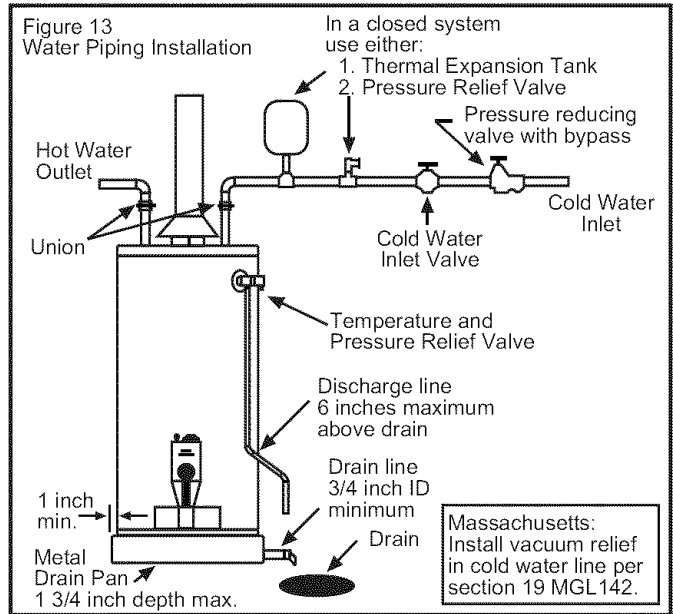

Please note the following:

DO NOT install this water heater with iron piping. The system should be installed only with new piping that is suitable for potable (drinkable) water such as copper, CPVC, or polybutylene. **DO NOT** use PVC water piping.

DO NOT use any pumps, valves, or fittings that are not compatible with potable water.

DO NOT use valves that may cause excessive restriction to water flow. Use full flow ball or gate valves only.

DO NOT use 50/50 tin-lead solder (or any lead based solder) in potable water lines. Use 95/5 tin-antimony or other equivalent material.

DO NOT tamper with the gas valve/thermostat, igniter, thermocouple, or temperature and pressure relief valve. Tampering voids all warranties. Only qualified technicians should service these components.

DO NOT use with piping that has been treated with chromates, boiler seal, or other chemicals.

DO NOT add any chemicals to the system piping which will contaminate the potable water supply.

Closed System/Thermal Expansion

Periodic discharge of the temperature and pressure relief valve may be due to thermal expansion in a closed water supply system. The water utility supply meter may contain a check valve, backflow preventer or water pressure reducing valve. This will create a closed water system. During the heating cycle of the water heater, the water expands causing pressure inside the water heater to increase. This may cause the temperature and pressure relief valve to discharge small quantities of hot water. To prevent this from happening, there are two recommendations:

1. Install a diaphragm-type expansion tank that is suitable for potable water on the cold water supply line. The expansion tank must have a minimum capacity of 1.5 U.S. gallons for every 50 gallons of stored water.
2. Install a 125 PSI pressure relief valve in the cold water supply line. Make sure the discharge of this valve is directed to an open drain and protected from freezing. Contact the local water supplier or plumbing inspector for information on how to control this situation. **Do not plug the temperature and pressure relief valve.**

Temperature and Pressure Relief Valve

! WARNING



Explosion Hazard

If the temperature and pressure relief valve is dripping or leaking, have a licensed plumber repair it.

Do not plug valve.

Do not remove valve.

Failure to follow these instructions can result in death, or explosion.

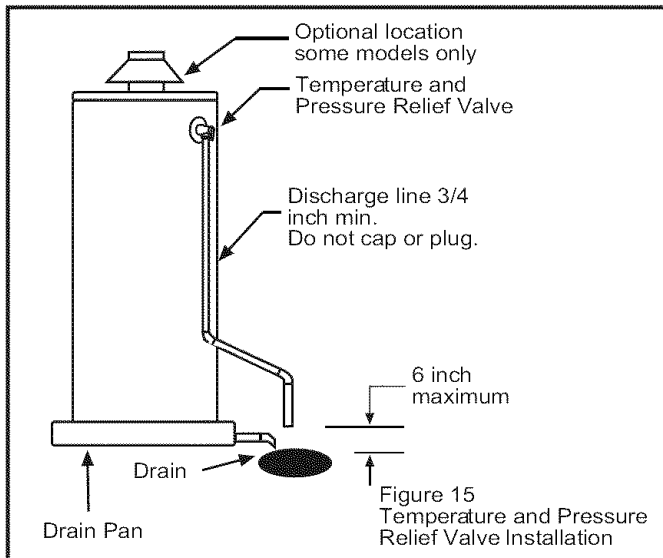

For protection against excessive pressures and temperatures, a temperature and pressure relief valve must be installed in the opening marked "T & P RELIEF VALVE" (see Figure 15). This valve must be design certified by a nationally recognized testing laboratory that maintains periodic inspection of the production of listed equipment or materials as meeting the requirements for Relief Valves and Automatic Shut-off Devices for Hot Water Supply Systems, ANSI Z21.22. The function of the temperature and pressure relief valve is to discharge water in large quantities in the event of excessive temperature or pressure developing in the water heater. The valve's relief pressure must not exceed the working pressure of the water heater as stated on the data plate.

Important: Only a new temperature and pressure relief valve should be used with your water heater. Do not use an old or existing valve as it may be damaged or not adequate for the working pressure of the new water heater. Do not place any valve between the relief valve and the tank.

The Temperature & Pressure Relief Valve:

- Must not be in contact with any electrical part.
- Must be connected to an adequate discharge line.
- Must not be rated higher than the working pressure shown on the data plate of the water heater.

The Discharge Line:

- Must not be smaller than the pipe size of the relief valve or have any reducing coupling installed in the discharge line.
- Must not be capped, blocked, plugged or contain any valve between the relief valve and the end of the discharge line.
- Must terminate a maximum of 6 inches above a floor drain or external to the building.
- Must be capable of withstanding 250°F (121°C) without distortion.
- Must be installed to allow complete drainage of both the valve and discharge line.

Special Applications

Combination Space Heating/ Potable Water System

Some water heater models are equipped with inlet/outlet tappings for use with space heating applications. If this water heater is to be used to supply both space heating and domestic potable (drinking) water, the instructions listed below must be followed.

- Be sure to follow the manual(s) shipped with the air handler system.
- This water heater is not to be used as a replacement for an existing boiler installation.
- Do not use with piping that has been treated with chromates, boiler seal or other chemicals and do not add any chemicals to the water heater piping.
- If the space heating system requires water temperatures in excess of 120°F, a tempering valve or an anti-scald device should be installed per its manufacturer's instructions in the domestic (potable) hot water supply to limit the risk of scald injury.
- Pumps, valves, piping and fittings must be compatible with potable water.
- A properly installed flow control valve is required to prevent thermosiphoning. Thermosiphoning is the result of a continuous flow of water through the air handler circuit during the off cycle. Weeping (blow off) of the temperature and pressure relief valve (T & P) or higher than normal water temperatures are the first signs of thermosiphoning.
- The domestic hot water line from the water heater should be vertical past any tempering valve or supply line to the air handler to remove air bubbles from the system. Otherwise, these bubbles will be trapped in the air handler heat exchanger coil, reducing the efficiency.
- Do not connect the water heater to any system or components previously used with non-potable water heating appliances when used to supply potable water.

Some jurisdictions may require a backflow preventer in the incoming cold water line. This may cause the temperature and pressure relief valve on the water heater to discharge or weep due to expansion of the heated water. A diaphragm-type expansion tank suitable for potable water will normally eliminate this weeping condition. Please read and follow the manufacturer's instructions for the installation of such tanks.

Also see "Water System Piping" (Page 12) for additional instructions on the safe and correct installation and operation of this water heater.

Solar Installation

If this water heater is used as a solar storage heater or as a backup for the solar system, the water supply temperatures to the water heater tank may be in excess of 120°F. A tempering valve or other temperature limiting valve must be installed in the water supply line to limit the supply temperature to 120°F.

Note: Solar water heating systems can often supply water with temperatures exceeding 180°F and may result in water heater malfunction.

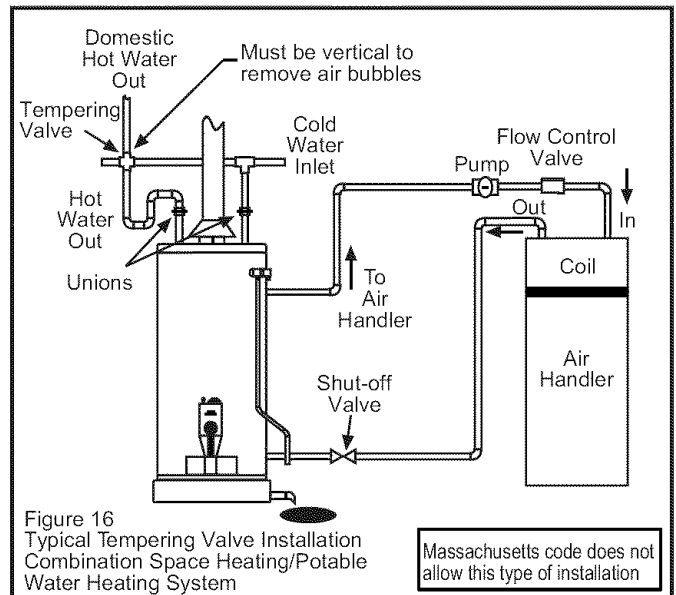

Installation Checklist

Water Heater Location

- Centrally located with the water piping system. Located as close to the gas piping and vent pipe system as possible.
- Located indoors and in a vertical position. Protected from freezing temperatures.
- Proper clearances from combustible surfaces maintained and not installed directly on a carpeted floor.
- Provisions made to protect the area from water damage. Drain pan installed and piped to an adequate drain.
- Installation area free of corrosive elements and flammable materials.
- Sufficient room to service the water heater.
- Water heater not located near an air moving device.

Combustion Air Supply and Ventilation

- Sufficient fresh air supply for proper water heater operation.
- Fresh air not taken from areas that contain negative pressure producing devices such as exhaust fans, fireplaces, etc.
- Fresh air supply free of corrosive elements and flammable vapors.
- Fresh air openings sized correctly with consideration given to the blocking effect of louvers and grilles.
- Ductwork is the same cross-sectional area as the openings.

Vent Pipe System

- Drafthood properly installed.
- Vent connectors securely fastened with screws and supported properly to maintain 6 inch clearance.
- Vent connector made of approved material and sized correctly.
- Vent pipe system in accordance to all local and state codes or in absence of local and state codes with the "National Fuel Gas Code", NFPA 54, ANSI Z223.1-latest edition.
- Flue baffle engaged in slots provided in the flue tube.
- Flue way, drafthood or vent pipe system not obstructed in any way.

Water System Piping

- Temperature and pressure relief valve properly installed with a discharge line run to an open drain and protected from freezing.
- All piping properly installed and free of leaks.
- Heater completely filled with water.
- Closed system pressure build-up precautions installed.
- Tempering valve installed per manufacturer's instructions.

Gas Supply and Piping

- Gas supply is the same type as listed on the water heater data plate.
- Gas line equipped with shut-off valve, union and drip leg.
- Approved pipe joint compound used.
- Adequate pipe size and of approved material.
- Chloride-free soap and water solution or other approved means used to check all connections and fittings for possible gas leaks.

OPERATING YOUR WATER HEATER

Lighting Instructions

Read and understand these directions thoroughly before attempting to light or re-light the pilot. Make sure the tank is completely filled with water before lighting the pilot. Check the data plate near the gas valve control/thermostat for the correct gas. Do not use this water heater with any gas other than the one listed on the data plate. If you have any questions or doubts, consult your gas supplier or gas utility company.

L.P.G. (Bottled Propane) Models

Liquefied Petroleum Gas is over 50% heavier than air and in the occurrence of a leak in the system the gas will settle at floor level. Basements, crawl spaces, skirted areas under mobile homes (even when ventilated), closets and areas below ground level will serve as pockets for the accumulation of gas. Before lighting an L.P. gas water heater, smell all around the appliance at floor level. If you smell gas, follow the instructions as given in the warning on the front page.

When your L.P. tank runs out of fuel, turn off the gas at all gas appliances including pilot lights. After the tank is refilled, all appliances must be re-lit according to their manufacturer's instructions.

⚠ WARNING



Explosion Hazard

Replace viewport if glass is missing or damaged.
Failure to do so can result in death, explosion or fire.

LIGHTING INSTRUCTIONS

1. Remove the outer door.
2. Turn the temperature dial counterclockwise ↺ to its lowest setting.

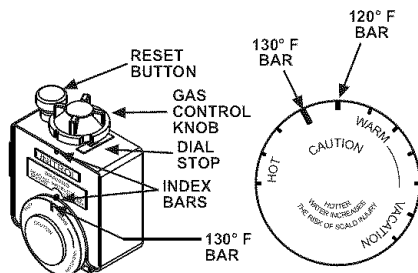

3. Turn gas control knob clockwise ↻ to the "OFF" position.
4. To clear any gas that may have accumulated wait ten (10) minutes.
If you then smell gas, STOP! Refer to the safety warning on the cover. If you do not smell gas go to the next step.
5. Turn the gas control knob counterclockwise ↺ to "PILOT".

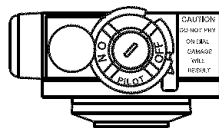
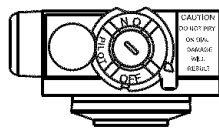

6. Depress the reset button all the way in and IMMEDIATELY depress the igniter button until you hear a loud click. Observe the pilot through the view port. Do not release the reset button. Repeat immediately if pilot does not light on the first try. If the pilot does not light by the fourth attempt with the igniter, repeat steps 3 - 6. Continue to hold the button for about (1) minute after the pilot is lit. Release the reset button and it will pop back up. Pilot should remain lit. If the pilot light goes out, repeat steps 2-6.



IMPORTANT: If the pilot will not stay lit after several tries, turn gas control knob to "OFF" and call your service technician or gas supplier.

IMPORTANT: If the reset button does not pop up when released, stop and immediately shut off the gas at the line valve or tank. Call your service technician or gas supplier.

7. Turn the gas control knob counterclockwise ↺ to "ON".
8. Set the temperature dial to the desired setting.
9. Replace the outer door.



TO TURN OFF GAS TO APPLIANCE

1. Turn the temperature dial counterclockwise ↺ to its lowest setting.
2. Turn the gas control knob clockwise ↻ to the "OFF" position.

Checking the Draft

WARNING

Burn Hazard
Do not touch vent.
Doing so can result in
burns.

After successfully lighting the water heater, allow the unit to operate for 15 minutes and check the drafthood relief opening for proper draft. Pass a match flame around the relief opening of the drafthood. A steady flame drawn into the opening indicates proper draft. If the flame flutters or is blown out, combustion products are escaping from the relief opening. If this occurs, do not operate the water heater until proper adjustments or repairs are made to the vent pipe system.

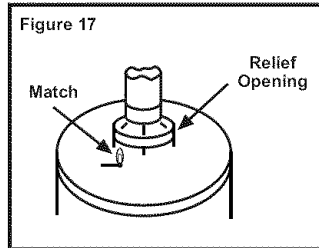

Burner Flames

Inspect the burner flames through the viewport and compare them to the drawings in Figure 18. A properly operating burner should produce a soft blue flame. Blue tips with yellow inner cones are satisfactory. The tips of the flame may have a slight yellow tint. The flame should not be all yellow or have a sharp blue-orange color. Contaminated air may cause an orange colored flame. Contact a qualified service technician if the flame is not satisfactory.

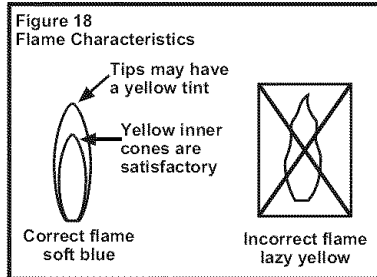

Stacking

Stacking occurs when a series of short draws of hot water (3 gallons or less) are taken from the water heater tank. This causes increased cycling of the burner and can result in increased water temperatures at the hot water outlet. An anti-scald device is recommended in the hot water supply line to reduce the risk of scald injury.

Emergency Shut Down

Important: Should overheating occur or the gas supply fails to shut off, turn off the water heater's manual gas control valve and call a qualified service technician.

Water Temperature Regulation

WARNING

Water temperature over 125°F can cause severe burns instantly or death from scalds.

Children, disabled and elderly are at highest risk of being scalded.

See instructions manual before setting temperature at water heater.

Feel water before bathing or showering.

Temperature limiting valves are available.

The thermostat is adjusted to its lowest temperature when it is shipped from the factory. Water temperature can be regulated by moving the temperature dial to the preferred setting. **The preferred starting point is 120°F.** Align the index bar on the thermostat with the desired water temperature as shown in Figure 19. **There is a hot water scald potential if the thermostat is set too high.**

Important: Adjusting the thermostat past the 120°F bar on the temperature dial will increase the risk of scald injury. Hot water can produce first degree burns within:

- 120°F (49°C) more than 5 minutes
- 130°F (54°C) at 20 seconds
- 140°F (60°C) at 3 seconds
- 150°F (66°C) at 1-1/2 seconds
- 160°F (71°C) at less than 1 second

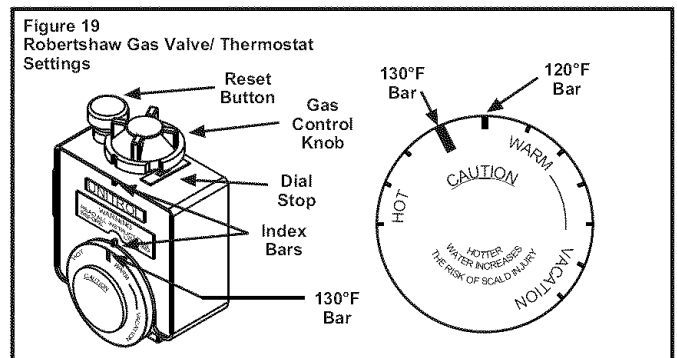

Note: During low demand periods when hot water is not being used, a lower thermostat setting will reduce energy losses and may satisfy your normal hot water needs. If hot water use is expected to be more than normal, a higher thermostat setting may be required to meet the increased demand. When leaving your home for extended periods (vacations, etc.) turn the temperature dial to its lowest setting. This will maintain the water at low temperatures with minimum energy losses and prevent the tank from freezing during cold weather.

Operational Conditions

Condensation

Moisture from the products of combustion condenses on the tank surface and the outside jacket of the water heater and forms drops of water which may fall onto the burner or other hot surfaces. This will produce a “sizzling” or “frying” noise. **This condensation is normal and should not be confused with a leaking tank.** Condensation may increase or decrease at different times of the year.

High efficient energy saver water heaters will produce larger amounts of condensation on initial start up or when a large amount of hot water is being used. **Do not confuse this with a “tank leak”.** Once the water reaches a temperature of 120°F and the tank warms up (usually 1-2 hours), the condensation will stop.

Important: It is always recommended that a suitable drain pan be installed under the water heater to protect the area from water damage resulting from normal condensation production, a leaking tank or piping connections. Refer to “Location Requirements” on page 4. Under no circumstances is the manufacturer to be held responsible for any water damage in connection with this water heater.

Water Heater Sounds

During the normal operation of the water heater, sounds or noises may be heard. These noises are common and may result from the following

1. Normal expansion and contraction of metal parts during periods of heat-up and cool-down.
2. Condensation causes sizzling and popping within the burner area and should be considered normal.
3. Sediment buildup in the tank bottom will create varying amounts of noise and may cause premature tank failure. Drain and flush the tank as directed under “Draining and Flushing”.

Smoke/Odor

The water heater may give off a small amount of smoke and odor during the initial start-up of the unit. This is due to the burning off of oil from metal parts of a new unit and will disappear after a few minutes of operation.

Safety Shut-off

This water heater is designed to automatically shut-off in the event of the following:

1. The pilot flame is extinguished for any reason.
2. The water temperature exceeds 180°F (83°C).
3. Excessive combustion chamber temperatures.
4. The ignition of flammable vapors.

A thermocouple is used to determine if a pilot flame is present and will shut off the gas supply to the main burner and the pilot burner if the flame is absent. In addition, as part of the Flame Lock™ safety system, this thermocouple is equipped with a thermal fuse

which is designed to disable the gas valve in the event of excessive combustion chamber temperatures or a flammable vapor ignition. If the fuse opens, the water heater cannot be used unless the thermocouple is replaced by a qualified service technician. Contact the **Product Service and Support Department** for service information at **1-877-817-6750**.

A high temperature limit switch or ECO (Energy Cut Off) in the tank is used to shut off the unit if the water temperature exceeds 180°F (83°C). The ECO is a single use switch and requires complete replacement of the entire thermostat. If the ECO should function, the water heater cannot be used until the thermostat is replaced by a qualified service agency. Contact your local dealer for service information.

Anode Rod/Water Odor

Each water heater contains at least one anode rod, which will slowly deplete while protecting the glass-lined tank from corrosion and prolonging the life of the water heater. Certain water conditions will cause a reaction between this rod and the water. Once the anode is depleted, the tank will start to corrode, eventually developing a leak. The most common complaint associated with the anode rod is a “rotten egg smell” produced from the presence of hydrogen sulfide gas dissolved in the water. **Do not remove this rod permanently as it will void any warranties, stated or implied.** The parts list includes a special anode that can be ordered if water odor or discoloration occurs. This rod may reduce but not eliminate water odor problems. The water supply system may require special filtration equipment from a water conditioning company to successfully eliminate all water odor problems.

Artificially softened water is exceedingly corrosive because the process substitutes sodium ions for magnesium and calcium ions. The use of a water softener may decrease the life of the water heater tank.

The anode rod should be removed from the water heater tank every 3 years for inspection. If the rod is more than 50% depleted, the anode rod should be replaced.

In replacing the anode:

1. Turn off gas supply to the water heater.
2. Shut off the water supply and open a nearby hot water faucet to depressurize the water tank.
3. Drain approximately 5 gallons of water from tank (Refer to “Draining and Flushing” for proper procedures). Close drain valve.
4. Remove old anode rod.
5. Use Teflon® tape or approved pipe sealant on threads and install new anode rod.
6. Turn on water supply and open nearby hot water faucet to purge air from water system.
7. Restart the water heater as directed under “Operating Your Water Heater.” See the “Repair Parts Illustration” for anode rod location on page 27.

MAINTENANCE OF YOUR WATER HEATER

Draining and Flushing

It is recommended that the tank be drained and flushed every 6 months to remove sediment which may buildup during operation. The water heater should be drained if being shut down during freezing temperatures. To drain the tank, perform the following steps:

1. Turn off the gas to the water heater at the Manual Gas Shut-off Valve.
2. Close the cold water inlet valve.
3. Open a nearby hot water faucet.
4. Connect a hose to the drain valve and terminate it to an adequate drain.

Note: The drain hose should be rated for at least 200°F. If the drain hose does not have this rating, open the cold water inlet valve and a nearby hot faucet until the water is no longer hot.

5. Open the water heater drain valve and allow all the water to drain from the tank. Flush the tank with water as needed to remove sediment.
6. Close the drain valve, refill the tank, and restart the heater as directed under "Operating Your Water Heater".

If the water heater is going to be shut down for an extended period, the drain valve should be left open.

Important: Condensation may occur when refilling the tank and should not be confused with a tank leak.

3 Month Inspection

At least every 3 months, a visual inspection should be made of the venting and air supply system, piping systems, main burner and pilot burner. Check the water heater for the following:

- Obstructions, damage, or deterioration in the venting system. Make sure the ventilation and combustion air supplies are not obstructed. See section titled "Cleaning the Combustion Chamber and Flame-trap."
- Build-up of soot and carbon on the main burner and pilot burner. Check for a soft blue flame.
- Leaking or damaged water and gas piping.
- Presence of flammable or corrosive materials in the installation area.
- Presence of combustible materials near the water heater.

Important: Verify proper operation after servicing this water heater.

Temperature and Pressure Relief Valve

! WARNING



Explosion Hazard

If the temperature and pressure relief valve is dripping or leaking, have a licensed plumber repair it.

Do not plug valve.

Do not remove valve.

Failure to follow these instructions can result in death, or explosion.

Manually operate the temperature and pressure relief valve at least once a year to make sure it is working properly. To prevent water damage, the valve must be properly connected to a discharge line which terminates at an adequate drain. Standing clear of the outlet

(discharged water may be hot), slowly lift and release the lever handle on the temperature and pressure relief valve to

allow the valve to operate freely and return to its closed position. If the valve fails to completely reset and continues to release water, immediately shut off the manual gas valve and the cold water inlet valve and call a qualified service technician.

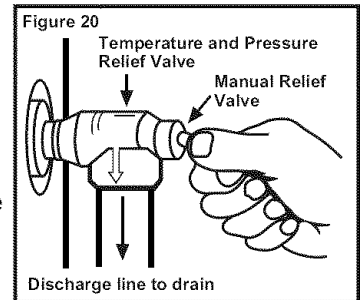

Self-Cleaning (Some Models)

Some water heaters may include a self-cleaning device that inhibits the build-up of lime and other sediment on the metal surfaces of the water heater. As cold water passes through the dip tube, lime-causing particles and minerals are suspended automatically. This controls sediment and lime build-up within the tank and results in higher efficiencies and lower operation costs.

Replacement Parts

The following maintenance procedures are for the Flame Lock™ safety system components and should be performed by a qualified service technician.

Replacement parts may be ordered through your plumber or the local distributor. Parts will be shipped at prevailing prices and billed accordingly. When ordering replacement parts, always have the following information ready:

1. Model, serial and product number.
2. Type of gas.
3. Item number.
4. Parts description.

See page 27 for a list of available repair parts.

Removing the Manifold Assembly

1. Turn off the gas to the water heater at the manual shut-off valve (Figure 3).
2. Turn the gas control knob on the combination gas control valve/thermostat clockwise to the "OFF" position (Figure 19).
3. Remove the outer door.
4. Remove the (2) screws securing the manifold door assembly to the skirt (Figure 22).
5. Disconnect the thermocouple (left-hand thread), pilot tube, the igniter wire from the igniter button, and manifold tube at the thermostat. (Figure 21.) **Note:** L.P. gas systems use reverse (left-hand) threads on the manifold tube.
6. Grasp the manifold tube and push down slightly to free the manifold, pilot tube, and thermocouple.
7. Carefully remove the manifold assembly from the burner compartment. **Be sure not to damage internal parts.**

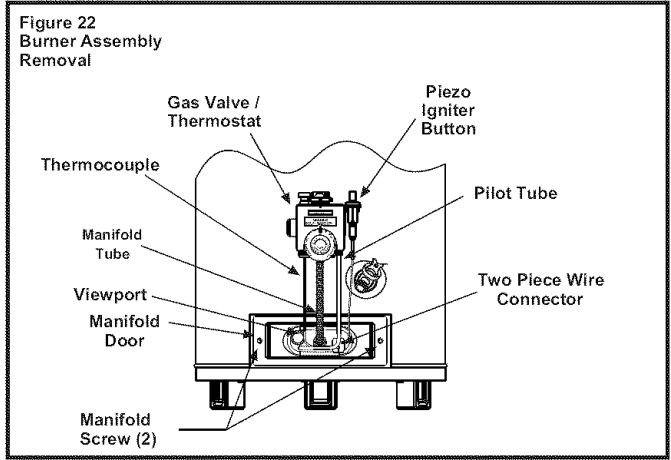
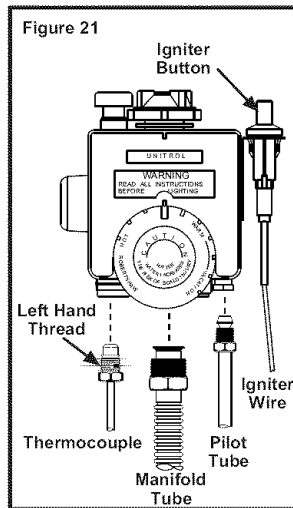

Removing the Burner from the Manifold Assembly

Natural Gas Burner

1. Turn the burner counterclockwise to remove it from the manifold assembly.
2. Check the burner to see if it is dirty or clogged. The burner may be cleaned with soap and hot water (Figure 23A).

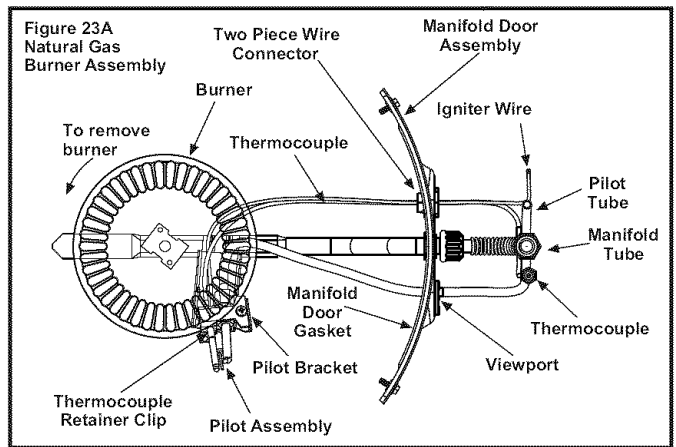

Natural Gas Burner (Low Nox)

1. Take off the burner by removing the two(2) screws located underneath the burner.
2. Check the burner to see if it is dirty or clogged. The burner may be cleaned with soap and hot water (Figure 23B).

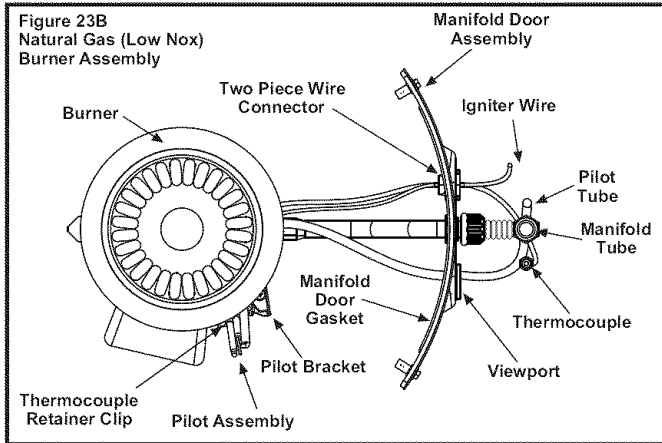

L.P. Gas Burner

1. Separate the pilot bracket from the L.P. burner by removing screw.
2. Loosen set screw located on top of the L.P. burner near the manifold door. Carefully, pull the burner away from the manifold door assembly.
3. Check the burner to see if it is dirty or clogged. The burner may be cleaned with soap and hot water (Figure 23C).

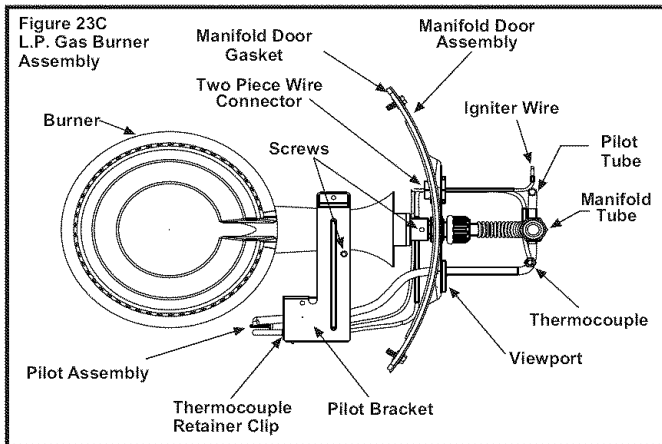

Replacing the Thermocouple

Important: Use only a factory authorized Flame Lock™ safety system thermocouple for replacement.

1. Remove the manifold assembly as directed previously.
2. Remove the retainer clip from the back of the two piece wire connector. Remove the two piece wire connector from the manifold door. Remove the thermocouple (Figure 24).
3. Pull the thermocouple from the pilot assembly. (Figures 23, and 27).
4. Push the new thermocouple through the holes in the pilot bracket. Insert the thermocouple tube into the holes provided in the pilot assembly until it clicks into place.
5. Position the new thermocouple through the larger opening of the two piece wire connector (Figure 24). **Note: Thermocouple contains a thermal fuse. Do not bend in the location shown below (Figure 25).** Be sure igniter wire is positioned through the small opening of the two piece wire connector.
6. See "Replacing Manifold Assembly" at the top of next column.

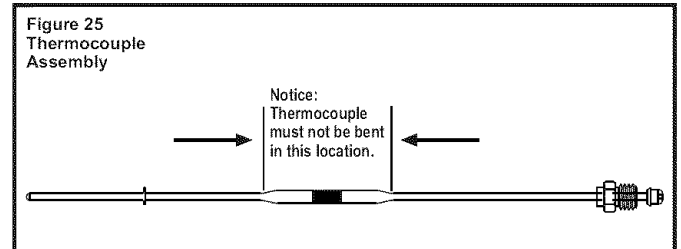
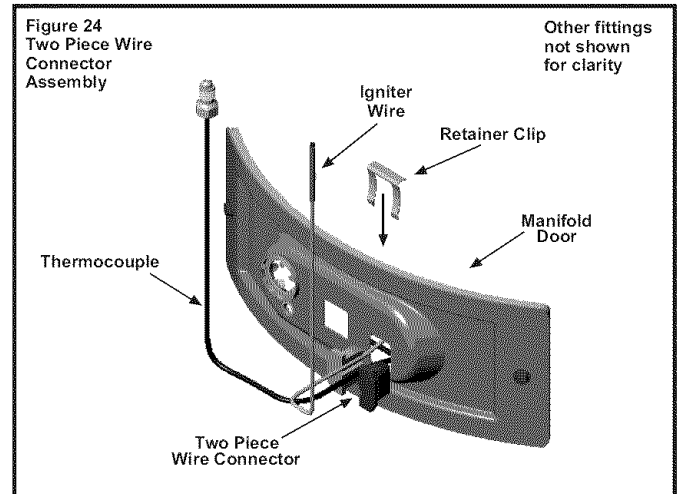

Cleaning the Combustion Chamber and Flame-trap

1. Follow procedure outlined in "Removing the Manifold Assembly".
2. Use a vacuum cleaner/shop vac to remove all loose debris in the combustion chamber and flame-trap. See Figure 26.
3. Reassemble following the procedure under "Replacing the Manifold Assembly".

Replacing the Manifold Assembly

! WARNING



Explosion Hazard

Tighten both manifold door screws securely.

Remove any fiberglass between gasket and combustion chamber.

Replace viewport if glass is missing or damaged.

Replace two piece wire connector if missing or removed.

Replace door gasket if damaged.

Failure to do so can result in death, explosion, or fire.

1. Check the door gasket for damage or imbedded debris prior to installation.
2. Inspect the viewport for damage and replace as required.
3. Insert the manifold assembly into the burner compartment making sure that tab of the manifold tube engages in the slot of the bracket inside the combustion chamber (Figure 26). The tab is located at the bottom of the burner for L.P. models.

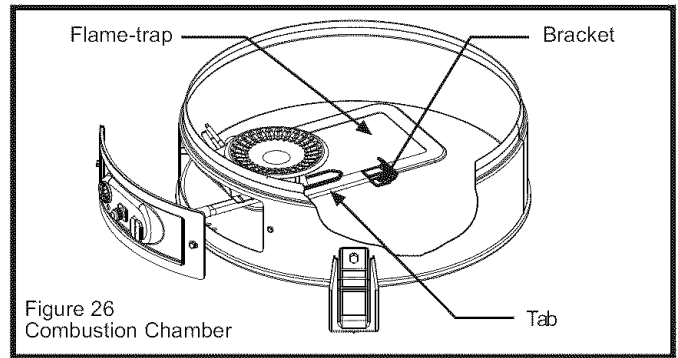

4. Inspect the door gasket and make sure there is no fiberglass insulation between the gasket and the combustion chamber.
5. Replace the two (2) screws which secure the manifold assembly door to the combustion chamber. Tighten securely. There should be no space between the gasket part of the manifold door and combustion chamber. **Do not operate the water heater if the door gasket is not sealed.**
6. Reconnect the manifold tubing, pilot tubing, and thermocouple to the thermostat. Do not cross-thread or apply any thread sealant to these fittings.
 - **Note:** L. P. gas systems use reverse (left-hand) threads on the manifold tube.
 - The thermocouple nut should be started and turned all the way in by hand. **Note:** These are left-hand threads. An additional quarter turn with a 7/16" open-end wrench will then be sufficient to seat the lockwasher.
7. Reconnect the igniter wire.
8. Turn gas supply on and refer to the "Lighting Instructions" on page 17.
9. Check for leaks. Use a chloride-free soap and water solution (bubbles forming indicate a leak) or other approved method. **All leaks must be fixed immediately.**
10. Replace the outer door.

Piezoelectric Igniter System

The piezoelectric igniter system is part of the Flame Lock™ safety system and consists of the igniter button, electrode and wire. The pilot is ignited by an electric spark generated when the igniter button is pressed. The spark gap of 0.125 inch is set when the electrode is installed at the factory. (See Figure 27A and 27B). Use only factory authorized Flame Lock™ safety system piezoelectric igniter parts for replacement.

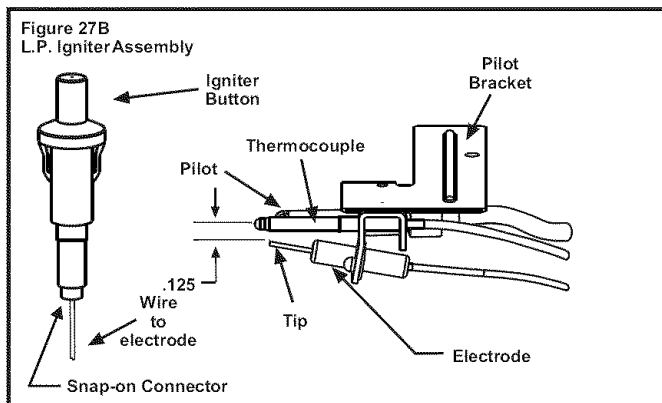
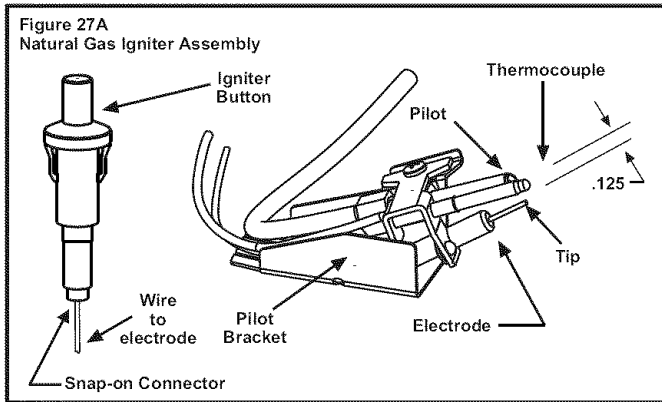

Testing the Igniter System

Turn off the gas to the water heater at the manual gas shut-off valve. Watch the electrode tip while activating the igniter. A visible spark should jump from the electrode. To avoid shock, do not touch the burner or any metal part on the pilot or pilot assembly. If no spark is visible, check the wire connections and make sure the electrode is not broken. Replace the igniter if defective. Dirt and rust on the pilot or electrode tip can prevent the igniter spark. Wipe clean with a damp cloth and dry completely. Rust can be removed from the electrode tip and metal surfaces by lightly sanding with an emery cloth or fine grit sandpaper.

Removing and Replacing the Gas Control Valve/Thermostat

Important: The gas control valve/thermostat is a standard valve with a left hand thread thermocouple that is unique to the Flame Lock™ safety system. Use only factory authorized replacement parts.

1. On the gas control valve/thermostat turn the temperature dial counterclockwise to its lowest setting. Turn the gas control knob clockwise to the "OFF" position (Figure 19).
2. Turn off the gas at the manual shut-off valve on the gas supply pipe (Figure 3).
3. Drain the water heater. Refer to the section of "Draining and Flushing" on page 20 and follow the procedure.
4. Disconnect the igniter wire from the igniter button. Remove the igniter button by depressing front and rear holding tabs and lift. Remove igniter bracket. Disconnect the thermocouple (left hand threads), pilot tube, and manifold tube at the thermostat (Figure 21). **Note:** L. P. gas systems use reverse(left-hand) threads on the manifold tube.
5. Refer to "Gas Piping" (Figure 3) and disconnect the ground joint union in the gas piping. Disconnect the remaining pipe from the gas valve/thermostat.

Important: When removing the gas control valve/thermostat do not use pipe wrench or vise to grip body. Do not insert any type of blunt instrument into the inlet or outlet connections. Using these type tools may result in damage to the gas control valve/thermostat.

6. Turn the gas control valve/thermostat counterclockwise. Remove the gas control valve/thermostat.

To replace the gas control valve/thermostat reassemble in reverse order. The gas control valve/thermostat is a standard valve with a left hand thread thermocouple that is unique to the Flame Lock™ safety system. Use only factory authorized replacement parts.

- Be sure to use approved Teflon tape or pipe joint compound on the gas piping connections and fitting on the back of gas valve that screws into tank.
- Be sure to remove the pilot ferrule nut from the new gas control valve/ thermostat.
- Turn gas supply on and check for leaks. Use a chloride-free soap and water solution (bubbles forming indicate a leak) or other approved method.
- Be sure tank is completely filled with water before lighting and activating the water heater. Follow the "Lighting Instructions" on page 17.
- If additional information is required, contact the Service Department at: **1-877-817-6750**.

Flame Lock™ Safety System Operational Checklist

1. Manifold gasket properly sealed.
2. Viewport not damaged or cracked.
3. Flame-trap free of debris and undamaged.
4. Two piece wire connector properly installed.
5. No leaks at pilot and manifold connection.
6. Manifold door screws securely tightened.

TROUBLESHOOTING CHART

PROBLEM	POSSIBLE CAUSE(S)	CORRECTIVE ACTION
BURNER WILL NOT IGNITE	<ol style="list-style-type: none"> 1. Pilot not lit 2. Thermostat set too low 3. No gas 4. Dirt in the gas lines 5. Pilot line clogged 6. Main burner line clogged 7. Defective thermocouple 8. Defective thermostat 9. Heater installed in a confined area 	<ol style="list-style-type: none"> 1. Light pilot 2. Turn temp. dial to desired temperature 3. Check with gas utility company 4. Notify utility-install trap in gas line 5. Clean, locate source and correct 6. Clean, locate source and correct 7. Replace thermocouple 8. Replace thermostat 9. Provide fresh air ventilation
SMELLY WATER	<ol style="list-style-type: none"> 1. Sulfides in the water 	<ol style="list-style-type: none"> 1. Replace the anode with a special anode
BURNER FLAME YELLOW-LAZY	<ol style="list-style-type: none"> 1. Insufficient secondary air 2. Low gas pressure 3. Flue clogged 4. Main burner line clogged 5. Heater installed in a confined area 6. Obstruction in main burner orifice 	<ol style="list-style-type: none"> 1. Provide ventilation to water heater 2. Check with gas utility company 3. Clean, locate source and correct 4. Clean, locate source and correct 5. Proper fresh air ventilation 6. Clean or replace orifice
PILOT WILL NOT LIGHT OR REMAIN LIT.	<ol style="list-style-type: none"> 1. Air in gas line 2. No gas 3. Dirt in gas lines 4. Pilot line or orifice clogged 5. Thermocouple connection loose 6. Defective thermocouple 7. Cold drafts 8. Thermostat ECO switch open 9. Temperature limit switch in combustion chamber Activated 10. Defective igniter 11. Flammable vapors incident, Flame Lock™ function utilized 12. Low gas pressure 	<ol style="list-style-type: none"> 1. Bleed the air from the gas line 2. Check with gas utility company 3. Notify utility-install dirt trap in gas line 4. Clean, locate source and correct 5. Finger tighten; then 1/4 turn with wrench 6. Replace thermocouple 7. Locate source and correct 8. Replace thermostat 9. Call 1-877-817-6750 10. Replace igniter pilot assembly 11. Replace water heater, eliminate flammable vapors source. Call 1-877-817-6750 12. Check with gas utility company
HIGH OPERATION COSTS	<ol style="list-style-type: none"> 1. Thermostat set too high 2. Sediment or lime in tank 3. Water heater too small for job 4. Wrong piping connections 5. Leaking faucets 6. Gas leaks 7. Wasted hot water 8. Long runs of exposed piping 9. Hot water piping in exposed wall 	<ol style="list-style-type: none"> 1. Set temperature dial to lower setting 2. Drain/Flush-Provide water treatment if needed 3. Install adequate heater 4. Correct piping-dip tube must be in cold inlet 5. Repair faucets 6. Check with utility-repair at once 7. Advise customer 8. Insulate piping 9. Insulate piping
INSUFFICIENT HOT WATER	<ol style="list-style-type: none"> 1. Thermostat set too low 2. Sediment or lime in tank 3. Water heater too small 4. Wrong piping connections 5. Leaking faucets 6. Wasted hot water 7. Long runs of exposed piping 8. Hot water piping in outside wall 9. Low gas pressure 	<ol style="list-style-type: none"> 1. Turn temperature dial to desired setting 2. Drain/flush-provide water treatment if needed 3. Install adequate heater 4. Correct piping-dip tube must be in cold inlet 5. Repair faucets 6. Advise customer 7. Insulate piping 8. Insulate piping 9. Check with gas utility company

continued on next page

TROUBLESHOOTING CHART (continued)

PROBLEM	POSSIBLE CAUSE(S)	CORRECTIVE ACTION
SLOW HOT WATER RECOVERY	<ol style="list-style-type: none"> 1. Insufficient secondary air 2. Flue clogged 3. Low gas pressure 4. Improper calibration 5. Thermostat set too low 6. Water heater too small 7. Wrong piping connections 8. Wasted hot water 	<ol style="list-style-type: none"> 1. Provide ventilation to water heater. Check flue way Flue baffle and burner 2. Clean flue, locate source and correct 3. Check with gas utility company 4. Replace thermostat 5. Turn temperature dial to desired setting 6. Install adequate heater 7. Correct piping-dip tube must be in cold inlet 8. Advise customer
DRIP FROM RELIEF VALVE	<ol style="list-style-type: none"> 1. Excessive water pressure 2. Heater stacking 3. Closed water system 	<ol style="list-style-type: none"> 1. Use a pressure reducing valve and relief valve 2. Lower the thermostat setting 3. See "Closed System/Thermal Expansion"
THERMOSTAT FAILS TO SHUT OFF	<ol style="list-style-type: none"> 1. Defective thermostat 2. Improper calibration 	<ol style="list-style-type: none"> 1. Replace thermostat 2. Replace thermostat
COMBUSTION ODORS	<ol style="list-style-type: none"> 1. Insufficient secondary air 2. Flue clogged 3. Heater installed in a confined area 	<ol style="list-style-type: none"> 1. Provide ventilation to water heater. Check flue way, flue baffle, burner 2. Clean, locate source and correct 3. Provide fresh air ventilation
SMOKING AND CARBON FORMATION (SOOTING)	<ol style="list-style-type: none"> 1. Insufficient secondary air 2. Low gas pressure 3. Flue clogged 4. Defective thermostat 5. Heater installed in a confined area 6. Burner flame yellow-lazy 	<ol style="list-style-type: none"> 1. Provide ventilation to water heater. Check flue way, flue baffle, burner 2. Check with gas utility company 3. Clean, locate source and correct 4. Replace thermostat 5. Provide fresh air ventilation 6. See "Burner Flame Yellow-Lazy"
CONDENSATION	<ol style="list-style-type: none"> 1. Temperature setting too low 	<ol style="list-style-type: none"> 1. Increase the temperature setting
BURNER FLAME FLOATS AND LIFTS OFF PORTS	<ol style="list-style-type: none"> 1. Orifice too large 2. High gas pressure 3. Flue clogged 4. Cold drafts 	<ol style="list-style-type: none"> 1. Replace with correct orifice 2. Check with gas utility company 3. Clean flue and burner-locate source & correct 4. Locate source and correct
BURNER FLAME TOO HIGH	<ol style="list-style-type: none"> 1. Orifice too large 	<ol style="list-style-type: none"> 1. Replace with correct orifice
FLAME BURNS AT ORIFICE	<ol style="list-style-type: none"> 1. Defective thermostat 2. Low gas pressure 	<ol style="list-style-type: none"> 1. Replace thermostat 2. Check with gas utility company
PILOT FLAME TOO SMALL	<ol style="list-style-type: none"> 1. Pilot line or orifice clogged 2. Low gas pressure 	<ol style="list-style-type: none"> 1. Clean, locate source and correct 2. Check with gas utility company

REPAIR PARTS ILLUSTRATION

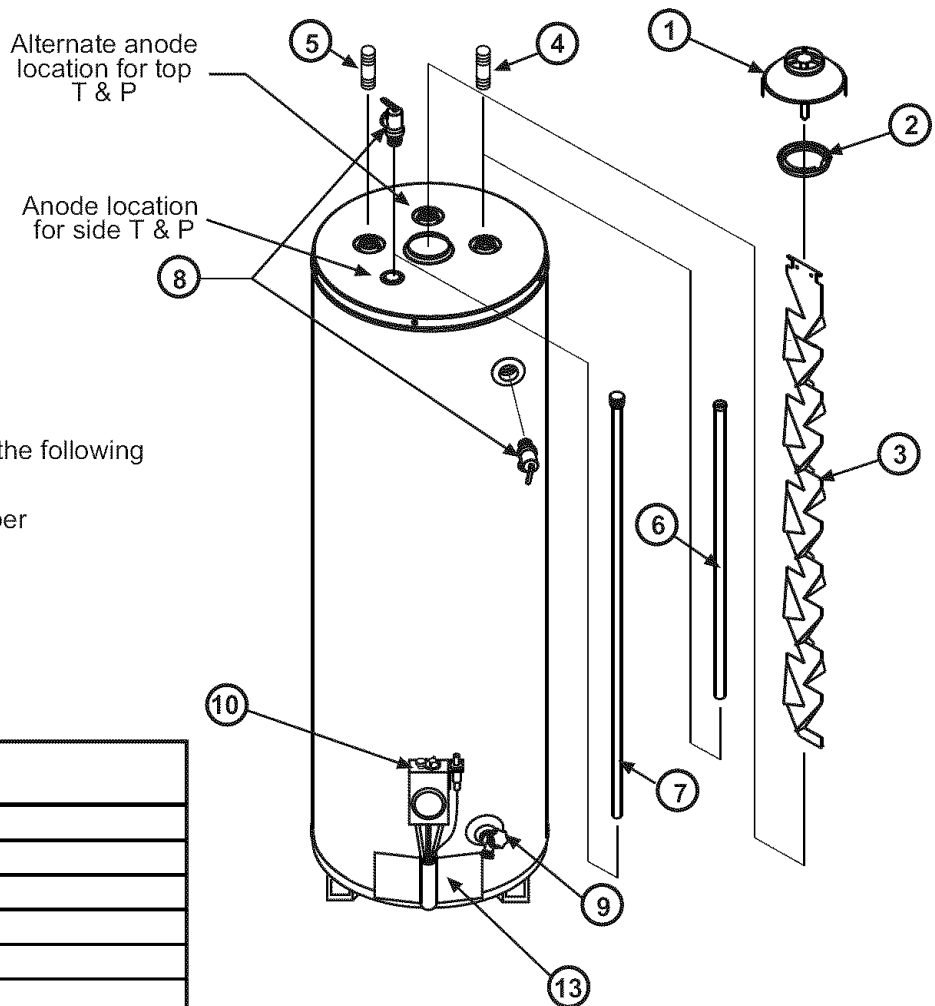

When ordering repair parts always give the following information:

1. Model, serial, and product number
2. Type of gas
3. Item number
4. Parts description

Repair Parts List

Item No.	Parts Description	
1	DRAFTHOOD	
2	REDUCER RING - SOME MODELS	
3	FLUE BAFFLE	
4	HEAT TRAP (COLD) - SOME MODELS	
5	HEAT TRAP (HOT) - SOME MODELS	
6	COLD WATER DIPTUBE	
7	ANODE ROD	▲
8	TEMPERATURE & PRESSURE RELIEF VALVE (LOCATED TOP OR SIDE)	■
9	DRAIN VALVE	
10	GAS VALVE/THERMOSTAT	★
11*	PILOT ASSEMBLY/THERMOCOUPLE KIT (Natural Gas)	★
12*	PILOT ASSEMBLY/THERMOCOUPLE KIT (L.P. Gas)	★
13	OUTER DOOR	
14*	MANIFOLD BURNER ASSEMBLY (Natural Gas)	★
15*	MANIFOLD BURNER ASSEMBLY (Natural Gas Low Nox)	★
16*	MANIFOLD BURNER ASSEMBLY (L.P. Gas)	★
17*	TWO PIECE WIRE CONNECTOR WITH RETAINER CLIP	★
18*	MANIFOLD DOOR GASKET	★
19*	VIEWPORT ASSEMBLY	★
20	THERMOCOUPLE ASSEMBLY (See page 22)	★

* Pictured on next page.

LEGEND

- ▲ Special anode rod (see page 19)
- Temperature and Pressure Relief Valve is required, but may not be factory installed.
- ★ Unique: Flame Lock™ safety system parts

Listed Part Kits and Illustrations

- Item 11:** Pilot assembly/thermocouple kit, which contains the pilot assembly with piezoelectric igniter, thermocouple, and retainer clip. (Natural Gas)
- Item 12:** Pilot assembly/thermocouple kit, which contains the pilot assembly with piezoelectric igniter, thermocouple, and retainer clip. (L.P. Gas)
- Item 14:** Manifold burner assembly which contains the manifold tube, gasket, door, pilot tube, thermocouple, two piece wire connector with retainer clip, and pilot assembly. (Natural Gas)
- Item 15:** Manifold burner assembly which contains the manifold tube, gasket, door, pilot tube, thermocouple, two piece wire connector with retainer clip, and pilot assembly. (Natural Gas Low Nox)
- Item 16:** Manifold burner assembly which contains the manifold tube, gasket, door, pilot tube, thermocouple, two piece wire connector with retainer clip, and pilot assembly. (L.P. Gas)
- Item 17:** Contains two piece wire connector with retainer clip, and pilot assembly.
- Item 18:** Contains manifold door gasket.
- Item 19:** Contains viewport.

