

Energy Smart[®] Residential Electric Water Heater Installation Instructions and Use & Care Guide

To obtain technical, warranty, or service assistance during or after the installation of this water heater, call toll free:

1-877-817-6750

When calling for assistance, please have the following information ready:

1. Model Number
 2. 7 Digit Product Number
 3. Serial Number
 4. Date of Installation
 5. Place of Purchase
-

Table Of Contents

	PAGE
Water Heater Safety	2
Installing Your Electric Water Heater	3-8
Unpacking Instructions	3
Location Requirements	4
Water System Piping	5
Electrical Requirements	7
Installation Checklist	8
Operating Your Water Heater	9-11
Water Heater Start-Up	9
Water Temperature Regulation	9
Operating the Temperature Control System	10
Operational Conditions	11
Maintenance of Your Water Heater	12-13
Diagnostic Code and Trouble Shooting Chart	14
Repair Parts Illustration	15

Your safety and the safety of others are very important.

We have provided many important safety messages in this manual and on your appliance. Always read and obey all safety messages.



This is the safety alert symbol.

This symbol alerts you to potential hazards that can kill or hurt you and others.

All safety messages will follow the safety alert symbol and either the word "DANGER" or "WARNING." These words mean:

⚠ DANGER

You can be killed or seriously injured if you don't immediately follow instructions.

⚠ WARNING

You can be killed or seriously injured if you don't follow instructions.

All safety messages will tell you what the potential hazard is, tell you how to reduce the chance of injury, and tell you what can happen if the instructions are not followed.

Important Safety Instructions

CAUTION: Hydrogen gas is produced in a hot water system served by this heater that has not been used for a long period of time (2 weeks or more). Hydrogen is extremely flammable. To reduce the risk of injury under these conditions, it is recommended that the hot water faucet be opened for several minutes at the kitchen sink before using any electrical appliance connected to the hot water system. When hydrogen is present, there will be an unusual sound such as air escaping through the pipe as the water begins to flow. There should be no smoking or open flame near the faucet at the time it is open.

The California Safe Drinking Water and Toxic Enforcement Act requires the Governor of California to publish a list of substances known to the State of California to cause cancer, birth defects, or other reproductive harm, and requires businesses to warn of potential exposure to such substances.

Warning: This product contains a chemical known to the State of California to cause cancer, birth defects, or other reproductive harm.

This appliance can cause low-level exposure to some of the substances listed, including formaldehyde.

INSTALLING YOUR WATER HEATER

Consumer Information

This water heater should be installed in accordance with the local code authority having jurisdiction, the power company or electric utility, and this installation manual. In the absence of local code requirements, follow the regulations set forth in the latest edition of the National Electric Code, NFPA 70. This is available from the following:

National Fire Protection Agency
1 Batterymarch Park
Quincy, MA 02269

American National Standards Institute
1430 Broadway
New York, NY 10018

Check your phone listings for the local authorities having jurisdiction over your installation.

Consumer Responsibilities

This manual has been prepared to acquaint you with the installation, operation, and maintenance of your electric water heater and to provide important safety information in these areas.

We urge you to read all of the instructions thoroughly before attempting the installation or operation of this water heater. This manual should be kept for future reference.

The manufacturer of this water heater will not be liable for any damages caused by failure to comply with the installation and operating instructions outlined in this manual.

If you lack the necessary skills required to properly install this water heater or you have difficulty following the instructions, you should not proceed but have a qualified person perform the installation of this water heater. Massachusetts code requires this water heater to be installed in accordance with Massachusetts Plumbing and Fuel Gas Code 248 CMR section 2.00 and 5.00.

A data plate identifying your water heater can be found adjacent to the element door. When referring to your water heater always have the information listed on the data plate readily available.

Retain your original receipt as proof of purchase.

Unpacking the Water Heater

Removing Packaging Materials

Important: Do not remove any permanent instructions, labels, or the data label from outside of the water heater or on the inside of panels.

- ▶ Remove exterior packaging and place installation components aside.
- ▶ Do not remove the envelope bag containing the water heater literature from the side of the water heater.
- ▶ Inspect all parts for damage prior to installation and start-up.
- ▶ Completely read all instructions before attempting to assemble and install this product.
- ▶ Replace this manual inside the envelope bag when installation is complete.
- ▶ After installation, dispose of packaging material in the proper manner.

Location Requirements

Site location

Select a location near the center of the water piping system. It must be installed indoors and in a vertical position on a level surface.

The water heater should be located in an area not subject to freezing temperatures. Water heaters located in unconditioned spaces (i.e., attics, basements, etc.) may require the water piping and drain piping to be insulated to protect against freezing. The drain and controls must be easily accessible for operation and service.

Do not use this water heater in conjunction with a spa or hot tub.

Note: Local codes and requirements in your area may require the water heater to be installed such that the bottom element is elevated from the floor at least 18 inches.

Important: The water heater should be located in an area where leakage of the tank or connections will not result in damage to the area adjacent to the water heater or to lower floors of the structure. Due to the normal corrosive action of the water, the tank will eventually leak after an extended period of time. It is recommended that a suitable drain pan be installed under the water heater as shown below. This pan is to protect the property from damage which may occur from normal condensate formation on the tank or leaks in the tank and pipe connections. The pan must limit the water level to a maximum depth of 2-1/2 inches and be two inches wider than the heater and piped to an adequate drain. Locate the water heater near a suitable indoor drain. Outdoor drains are subject to freezing temperatures which can obstruct the drain line. The piping should be at least 3/4" ID and pitched for proper drainage.

Under no circumstance will the manufacturer be held liable for any water damage in connection with this water heater.

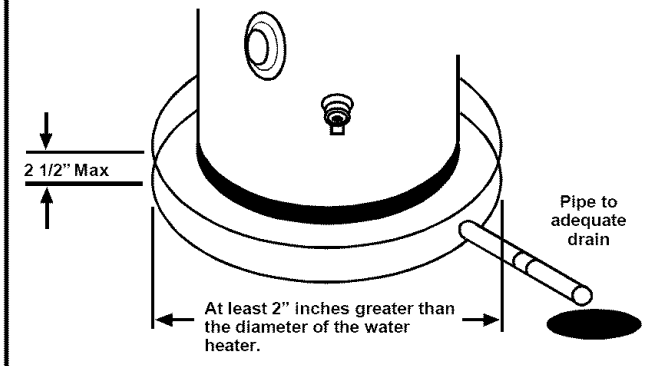

Note: The water heater shall be located so it is not subject to physical damage by moving vehicles or area flooding.

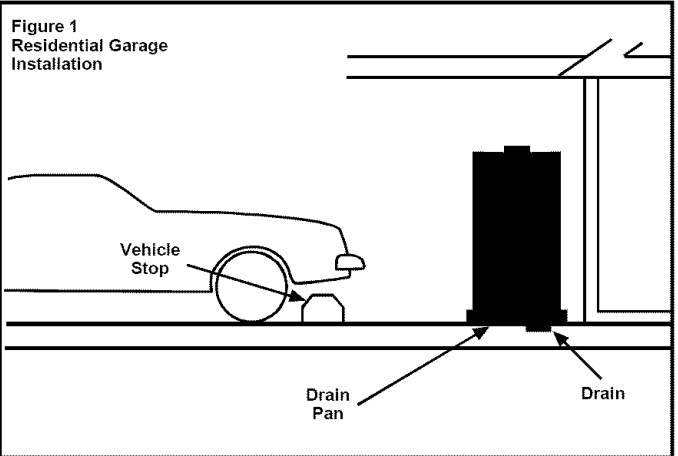

State of California

Note: The water heater must be braced, anchored, or strapped to avoid moving during an earthquake. Contact local utilities for code requirements in your area or call 1-877-817-6750 and request instructions.

Water System Piping

Piping Installation

Piping, fittings, and valves should be installed according to the installation drawing (Figure 2). If the indoor installation area is subject to freezing temperatures, the water piping must be protected by insulation.

Water supply pressure should not exceed 80% of the working pressure of the water heater. The working pressure is stated on the water heater's data plate. If this occurs a pressure limiting valve with a bypass may need to be installed in the cold water supply line. This should be placed on the supply to the entire house in order to maintain equal hot and cold water pressures.

Important: Heat cannot be applied to the water fittings on the heater as they may contain nonmetallic parts. If solder connections are used, solder the pipe to the adapter before attaching the adapter to the hot and cold water fittings.

Important: Always use a good grade of joint compound and be certain that all fittings are drawn up tight.

1. Install the water piping and fittings as shown in Figure 2. Connect the cold water supply (3/4 NPT) to the fitting marked "C". Connect the hot water supply (3/4 NPT) to the fitting marked "H".

Important: Some models may contain energy saving heat traps to prevent the circulation of hot water within the pipes. Do not remove these inserts.

2. The installation of unions in both the hot and cold water supply lines is recommended for ease of removing the water heater for service or replacement.
3. The manufacturer of this water heater recommends installing a tempering valve in the domestic hot water line as shown in Figures 3 and 4. These valves reduce the point-of-use temperature of the hot water by mixing cold and hot water and are readily available. Contact a licensed plumber or the local plumbing authority.
4. If installing the water heater in a closed water system, install a relief valve or expansion tank in the cold water line as specified under "Closed System/Thermal Expansion".
5. Install a shut-off valve in the cold water inlet line. It should be located close to the water heater and be easily accessible. Know the location of this valve and how to shut off the water to the heater.
6. Install a temperature and pressure relief valve and discharge line in the opening marked "T & P RELIEF VALVE". Install as specified under "Temperature and Pressure Relief Valve."
7. After piping has been properly connected to the water heater, open the nearest hot water faucet and allow the tank to completely fill with water. To purge the lines of any excess air and sediment, keep the hot water faucet open for 3 minutes after a constant flow of water is obtained. Close the faucet and check all connections for leaks.

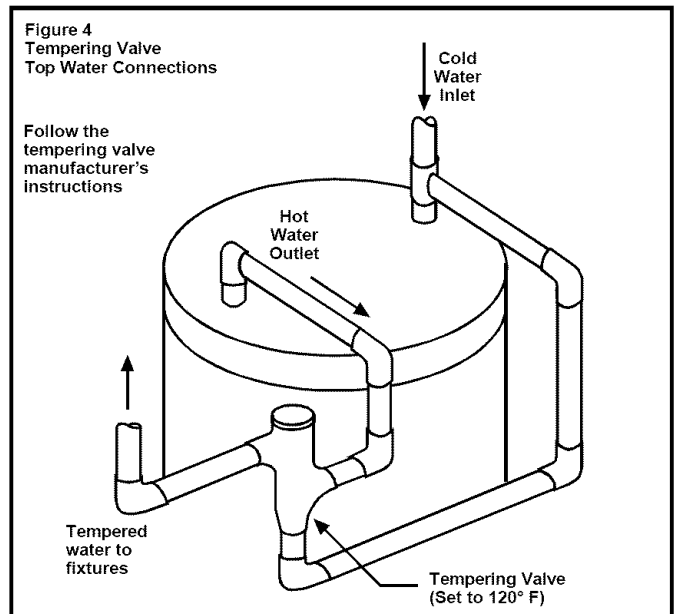
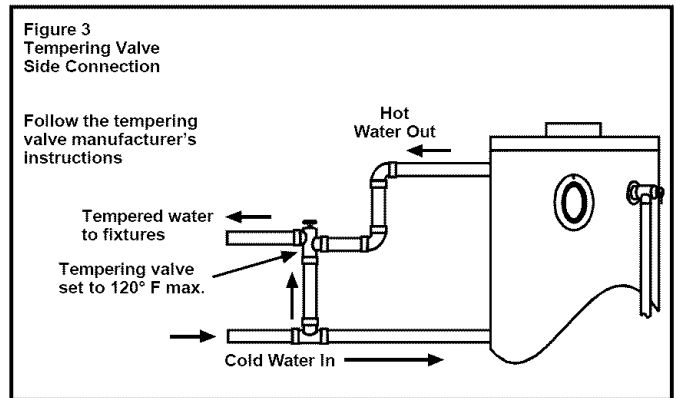
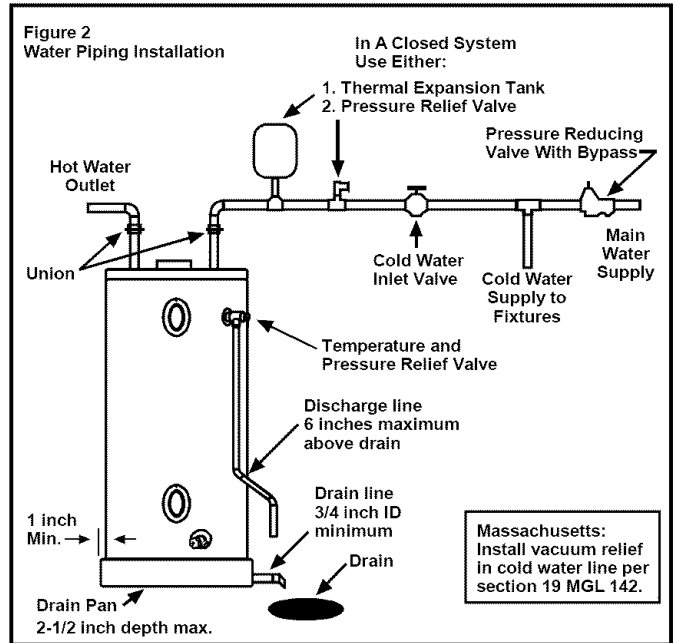

Please note the following:

DO NOT install this water heater with iron piping. The system should be installed only with new piping that is suitable for potable (drinkable) water such as copper, CPVC, or polybutylene. **DO NOT** use PVC water piping.

DO NOT use any pumps, valves, or fittings that are not compatible with potable water.

DO NOT use valves that may cause excessive restriction to water flow. Use full flow ball or gate valves only.

DO NOT use 50/50 tin-lead solder (or any lead based solder) in potable water lines. Use 95/5 tin-antimony or other equivalent material.

DO NOT tamper with the electronic control board, temperature sensors, heating elements, electrical connections, or temperature and pressure relief valve. Tampering voids all warranties. Only qualified technicians should service these components.

DO NOT use with piping that has been treated with chromates, boiler seal, or other chemicals.

DO NOT add any chemicals to the system piping which will contaminate the potable water supply.

Closed System/Thermal Expansion

Periodic discharge of the temperature and pressure relief valve may be due to thermal expansion in a closed water supply system. The water utility supply meter may contain a check valve, backflow preventer, or water pressure reducing valve. This will create a closed water system. During the heating cycle of the water heater, the water expands causing pressure inside the water heater to increase. This may cause the temperature and pressure relief valve to discharge small quantities of hot water. To prevent this from happening, there are two recommendations:

1. Install a diaphragm-type expansion tank that is suitable for potable water on the cold water supply line. The expansion tank must have a minimum capacity of 1.5 U.S. gallons for every 50 gallons of stored water.
2. Install a 125 PSI pressure relief valve in the cold water supply line. Make sure the discharge of this valve is directed to an open drain and protected from freezing. Contact the local water supplier or plumbing inspector for information on how to control this situation. **Do not plug the temperature and pressure relief valve.**

Temperature and Pressure Relief Valve

⚠ WARNING



Explosion Hazard

If the temperature and pressure relief valve is dripping or leaking, have a licensed plumber repair it.

Do not plug valve.

Do not remove valve.

Failure to follow these instructions can result in death or explosion.

Figure 5
Temperature and Pressure
Relief Valve Installation

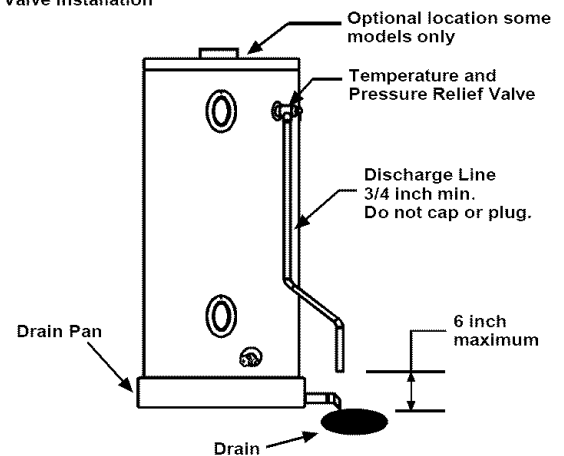

For protection against excessive pressures and temperatures, a temperature and pressure relief valve must be installed in the opening marked "T & P RELIEF VALVE" (See Figure 5).

Caution: To reduce the risk of excessive pressures and temperatures in this water heater, install temperature and pressure relief protective equipment required by local codes, but not less than a combination temperature and pressure relief valve certified by a nationally recognized testing laboratory that maintains periodic inspection of the production of listed equipment or materials, as meeting the requirements for Relief Valves and Automatic Shutoff Devices for Hot Water Supply Systems, ANSI Z21.22 -1986. This valve must be marked with the maximum set pressure not to exceed the marked maximum working pressure of the water heater. Install the valve into an opening provided and marked for this purpose in the water heater, and orient it or provide tubing so that any discharge from the valve exits only within 6 inches above, or at any distance below, the structural floor, and does not contact any live electrical part. The discharge opening must not be blocked or reduced in size under any circumstance.

Important: Only a new temperature and pressure relief valve should be used with your water heater. Do not use an old or existing valve as it may be damaged or not adequate for the working pressure of the new water heater. Do not place any valve between the relief valve and the tank.

The Temperature & Pressure Relief Valve:

- ▶ Must be connected to an adequate discharge line.
- ▶ Must not be in contact with any electrical part.
- ▶ Must not be rated higher than the working pressure shown on the data plate of the water heater.

The Discharge Line:

- ▶ Must terminate a maximum of 6 inches above a floor drain or external to the building.
- ▶ Must be capable of withstanding 250°F (121°C) without distortion.
- ▶ Must be installed to allow complete drainage of both the valve and discharge line.
- ▶ Must not be smaller than the pipe size of the relief valve or have any reducing coupling installed in the discharge line.
- ▶ Must not be capped, blocked, plugged, or contain any valve between the relief valve and the end of the discharge line.

Solar Installation

If this water heater is used as a solar storage heater or as a backup for the solar system, the water supply temperatures to the water heater tank may be in excess of 120°F. A tempering valve or other temperature limiting valve must be installed in the water supply line to limit the supply temperature to 120°F.

Note: Solar water heating systems can often supply water with temperatures exceeding 180°F and may result in water heater malfunction.

Electrical Requirements

⚠ WARNING	
	Electric Shock Hazard Disconnect power before servicing. Replace all parts and panels before operating. Failure to do so can result in death or electric shock.
	⚠ WARNING
	Fire Hazard Use 10 gauge solid copper wire. Use a UL approved strain relief. Connect ground wire to green ground screw. Failure to do so can result in death, fire, or electrical shock.

If you lack the necessary skills required to properly install the electrical wiring to this water heater, do not proceed, but have a qualified electrician perform the installation.

When making the electrical connections, always make sure:

- ▶ The electrical supply has the proper overload fuse or circuit breaker protection.
- ▶ Wire sizes and connections comply with all applicable codes.
- ▶ Wiring is enclosed in approved conduit (if required by local codes).
- ▶ The water heater and electrical supply are properly grounded.

Figure 6 and the wiring diagram can be found on the next page. Always reference the wiring diagram for the correct electrical connection. The wiring diagram can also be found on the inside of the junction box cover.

When installing the electrical wiring to the water heater:

1. Shut off the power to the unit.
2. Be sure tank is completely filled with water before making any electrical connections.
3. Remove junction box cover that is secured by 3 screws. Place the cover aside and view the wiring diagram on the inside.
4. Connect the electrical supply to the water heater in accordance with the local utility requirements and codes. A standard 1/2 inch opening has been made in the junction box for the conduit connections. Use approved conduit with copper wires only or Romex.

5. Ground the water heater by connecting the grounding wire from the electrical service ground to the (green) ground screw located in the junction box. **Note:** Only use 10 gauge wires for electrical connections and a 30 ampere double pole breaker.
6. Connect the red and black wires to the incoming power leads.
7. Replace cover and secure with screws.

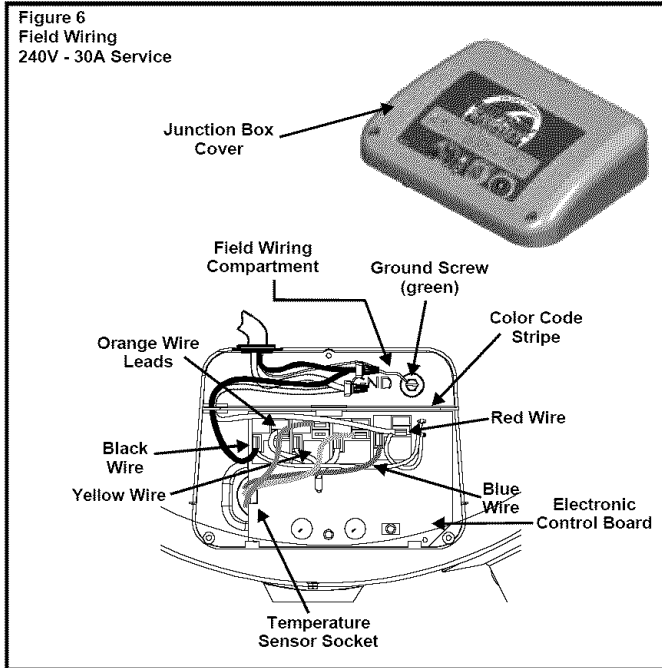

Wiring Diagram
240 Volts Only

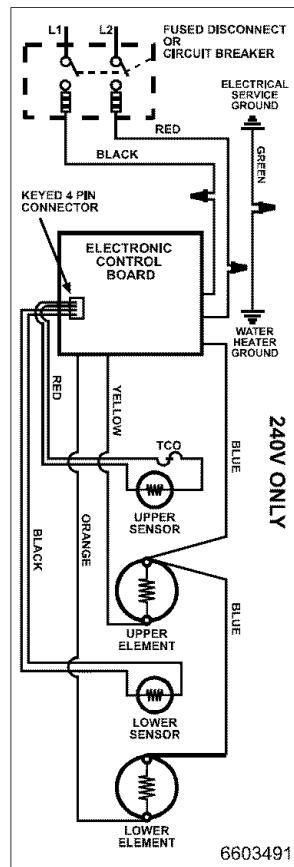

Installation Checklist

Water Heater Location

- ▶ Centrally located with the water piping system.
- ▶ Located indoors and in a vertical position.
- ▶ Protected from freezing temperatures.
- ▶ Provisions made to protect the area from water damage.
- ▶ Drain pan installed and piped into an adequate drain.
- ▶ Sufficient clearance to service the water heater.

Water System Piping

- ▶ Temperature and pressure relief valve properly installed with a discharge line plumbed to an open drain and protected from freezing.
- ▶ All piping properly installed and free of leaks.
- ▶ Water heater completely filled with water.
- ▶ Closed system pressure buildup precautions installed.
- ▶ Tempering valve installed per manufacturer's instructions.

Electrical Connections

- ▶ Wiring and connections comply with all applicable codes.
- ▶ Water heater and electrical supply are properly grounded.
- ▶ Proper overload fuse or circuit breaker protection installed.

OPERATING YOUR WATER HEATER

Water Heater Start-Up

1. Before operating the water heater, make sure the water heater has been properly installed.
2. Completely fill the tank with water.
3. Carefully read and understand the section, "Water Temperature Regulation", of this manual and adjust the temperature control knob to the desired setting.
4. Read the section, "Operating Mode Descriptions" on page 10 and select the desired operating mode.
5. After the tank is completely filled with water, turn on power to the water heater. **Note:** The water heater performs self-diagnostics that takes approximately 10 minutes. During this time, the elements may not be energized. If a failure is detected, the Diagnostic Light flashes the related failure code. See page 14 for "Diagnostic Code Chart."

Important: Operation of this water heater without access doors or insulation could result in much higher water temperatures than the desired set point, increasing the risk of scald injury. Do not operate water heater with the access doors or insulation removed.

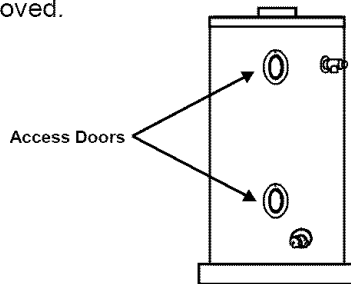

Important: Do not attempt to operate this water heater if the temperature sensor(s), electronic control board, or surrounding insulation has been exposed to water in any way. Immediately call a qualified service technician to inspect the water heater and replace any temperature sensor(s), electronic control board, or insulation that has been exposed to water. Do not attempt to repair these parts. Water heaters subjected to flood conditions or any time the temperature sensor(s) or electronic control board have been submerged in water require replacement of the entire water heater.

Safety Shut-off

This water heater is equipped with a high limit control switch that is designed to shut off the power to the elements if the water temperature exceeds 170°F (77°C). Use the diagnostic control chart on page 14 to help determine the cause of the high limit shut-off. After the cause has been corrected, reset the control as directed under "Reset Function" on page 10.

Water Temperature Regulation

⚠ WARNING

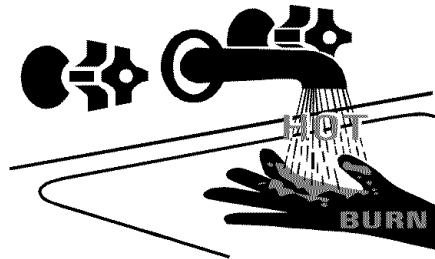

Water temperature over 125°F can cause severe burns instantly or death from scalds.

Children, disabled, and elderly are at highest risk of being scalded.

See the instruction manual before setting temperature at water heater.

Feel water before bathing or showering.

Temperature limiting valves are available.

The temperature control is adjusted to a setting of 120°F or lower when it is shipped from the factory. Water temperature can be regulated by adjusting the temperature control system to the preferred setting as shown in "Operating the Temperature Control System." **The recommended starting point is 120°F. There is a hot water scald potential if the temperature control is set too high.**

Important: Adjusting the temperature past 120°F on the temperature control will increase the risk of scald injury. Hot water can produce first degree burns within:

120°F (49°C) more than 5 minutes

130°F (54°C) at 20 seconds

140°F (60°C) at 3 seconds

150°F (66°C) at 1-1/2 seconds

160°F (71°C) at less than 1 second

Operating the Temperature Control System

Figure 7
Temperature Control
System



Water Temperature Adjustment

The water temperature can be adjusted from 80°F to 150°F. Use the temperature control knob to change to the desired temperature.

Operating Mode Descriptions

1. **Smart Mode** - The controller operates the water heater to maintain the customer's selected temperature.
2. **Energy Smart Mode** - The controller adjusts the water temperature to lowest temperature required to meet the household demands. This mode minimizes operating costs. The controller will not adjust temperature higher than customer's selected set point or lower than 115°F.
3. **Low Temperature Mode** - The controller limits the water temperature to 120°F or at the temperature selected whichever is lower. See page 9 for more information on scalds.
4. **Vacation/Cabin Mode** - The controller adjusts the water temperature to approximately 50°F. This mode is recommended when the water heater is not in use for a long period of time. This effectively turns the water heater off and prevents the water from freezing.

Diagnostic Indicator Light Analysis

- ▶ **Light On** - Indicates power applied and operating correctly.
- ▶ **Light Off** - Indicates no power or a controller problem.
- ▶ **One Flash** - Indicates the power was applied to water heater before the tank filled with water.
- ▶ **Two Flashes** - Indicates the high limit temperature has been reached.
- ▶ **Three Flashes** - Indicates a problem with the temperature sensors.
- ▶ **Four Flashes** - Check upper element.
- ▶ **Five Flashes** - Check lower element.

Reset Function

The reset function is used to restart the Temperature Control System after an error condition has been detected and corrected.

Reset the control by pushing the red reset button on the controller. After a reset, the control performs self diagnostics before normal operations begin. This takes approximately 10 minutes.

Operation Conditions

Anode Rod/Water Odor

Each water heater contains at least one anode rod, which will slowly deplete while protecting the glass-lined tank from corrosion and prolonging the life of the water heater. Certain water conditions will cause a reaction between this rod and the water. Once the anode is depleted, the tank will start to corrode, eventually developing a leak.

The most common complaint associated with the anode rod is a "rotten egg smell" produced from the presence of hydrogen sulfide gas dissolved in the water. **Do not remove this rod permanently as it will void any warranties, stated or implied.**

The parts list includes a special anode that can be ordered if water odor or discoloration occurs. This rod may reduce but not eliminate water odor problems. The water supply system may require special filtration equipment from a water conditioning company to successfully eliminate all water odor problems.

Artificially softened water is exceedingly corrosive because the process substitutes sodium ions for magnesium and calcium ions. The use of a water softener may decrease the life of the water heater tank.

The anode rod should be removed from the water heater tank every 3 years for inspection. If the rod is more than 50% depleted, the anode rod should be replaced. (See "Replacing the Anode Rod" in the maintenance section.)

Water Heater Sounds

During the normal operation of the water heater, sounds or noises may be heard. These noises are common and may result from the following:

1. Normal expansion and contraction of metal parts during periods of heat-up and cool-down.
2. Sediment buildup in the tank bottom will create varying amounts of noise and may cause premature tank failure. Drain and flush the tank as directed under "Draining and Flushing".

Stacking

Stacking occurs when a series of short draws of hot water (3 gallons or less) are taken from the water heater tank. This causes increased cycling of the heater elements and can result in increased water temperatures at the hot water outlet. An anti-scald device is recommended in the hot water supply line to reduce the risk of scald injury.

MAINTENANCE OF YOUR WATER HEATER

If you lack the necessary skills required to properly service this water heater or you have difficulty following the instructions, you should not proceed but have a qualified person perform the maintenance of this water heater.

Draining and Flushing

It is recommended that the tank be drained and flushed every 6 months to remove sediment which may buildup during operation. To drain the tank perform the following steps:

1. Turn off the power to water heater.
2. Close the cold water inlet valve and open a nearby hot water faucet.
3. Connect a hose to the drain valve and terminate it to an adequate drain.

Important: Drain hose should be rated for at least 200°F. If the drain hose does not have this rating, open the cold water inlet valve and open a nearby hot water faucet until water is no longer hot.

4. Open the water heater drain valve and allow all the water to drain from the tank. Flush the tank with water as needed to remove sediment.
5. Close the drain valve and refill the tank until water flows from the open hot water faucet. Allow water to run for a couple of minutes to make sure all air is out of tank.
6. Restart the water heater as directed under "Operating Your Water Heater." If the water heater is going to be shut down for an extended period, the drain valve should be left open.

Replacing the Anode Rod

1. Turn off the power to the water heater.
2. Shut off the water supply and open a nearby hot water faucet to depressurize the water tank.
3. Drain approximately 5 gallons of water from the tank. (Refer to "Draining and Flushing" for proper procedures.) Close drain valve.
4. Remove old anode rod.
5. Use Teflon[®] tape or approved pipe sealant on threads and install new anode rod.
6. Turn on water supply and open nearby hot water faucet to purge air from water system.
7. Restart the water heater as directed under "Operating Your Water Heater." See the "Repair Parts Illustration" for anode rod location on page 15.

Temperature and Pressure Relief Valve

⚠ WARNING



Explosion Hazard

If the temperature and pressure relief valve is dripping or leaking, have a licensed plumber repair it.

Do not plug valve.

Do not remove valve.

Failure to follow these instructions can result in death or explosion.

Manually operate the temperature and pressure relief valve at least once a year to make sure it is working properly. To prevent water damage, the valve must be properly connected to a discharge line which terminates at an adequate drain.

Standing clear of the outlet (discharged water may be hot), slowly lift and release the lever

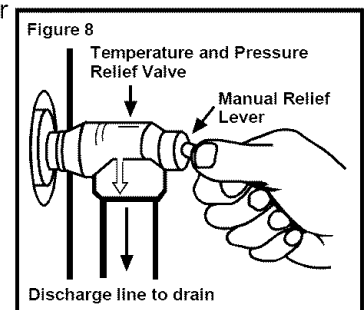

the temperature and pressure relief valve to allow the valve to operate freely and return to its closed position. If the valve fails to completely reset and continues to release water, immediately shut off the electrical power and the cold water inlet valve and call a qualified service technician.

Heating Element Replacement

⚠️ WARNING



Electrical Shock Hazard
 Disconnect power before servicing.
 Replace all parts and panels before operating.
 Failure to do so can result in death or electrical shock.

Replacement heating elements must be of the same style and voltage/wattage rating as the ones presently in the water heater. This information can be found on the flange or terminal block of the element or on the water heater data plate.

1. Shut off the electric power to the water heater.
2. Drain the water heater as directed under "Draining and Flushing".
3. Remove the access door(s), insulation and element cover(s).
4. Disconnect the electric wires from the heating element (Figure 9). Remove the screw-in elements by turning the element counterclockwise with an 1-½ inch socket wrench. Remove the existing gasket.

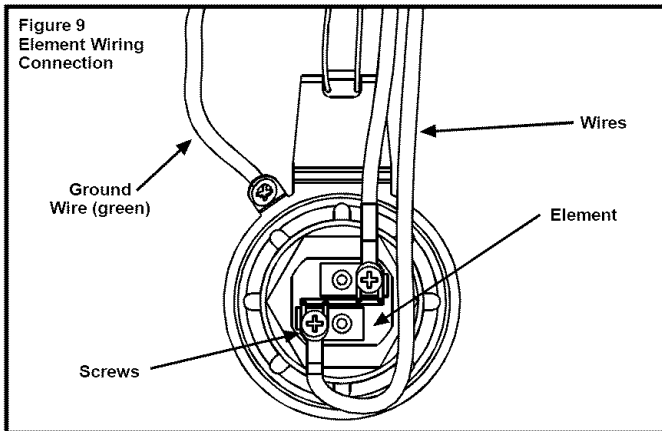

5. Clean the area where the gasket fits to the tank. If you are replacing the bottom element, remove the accumulated sediment on the bottom of the tank. Refer to "Draining and Flushing."
6. Make sure the replacement element has the correct voltage and wattage rating. Position the new gasket on the element and insert it into the water heater tank (Figure 10). Tighten the element by turning it clockwise until secure.

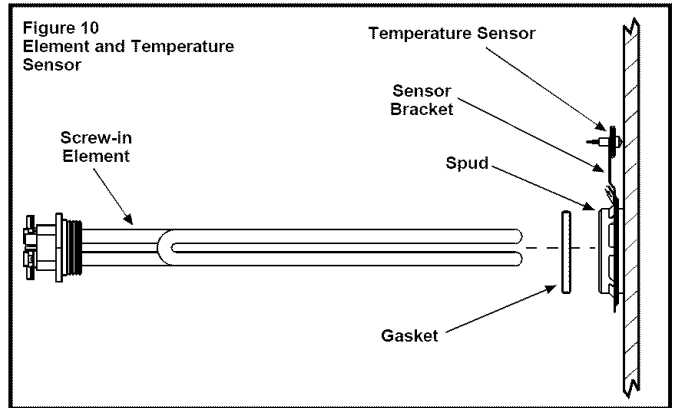

7. Close the drain valve. Open the nearest hot water faucet and allow the tank to fill completely with water. To purge the lines of any excess air and sediment, keep the hot water faucet open for 3 minutes after a constant flow of water is obtained.
 8. Check for leaks around the element(s).
 9. Connect the electric wires to the heater element. Make sure all wires are secure.
 10. Replace the insulation and access door(s).
- Important:** Operation of this water heater without access doors or insulation could result in much higher temperatures than the desired set point, increasing the risk of scald injury. Do not operate water heater with the access doors or insulation removed.
11. Make certain the tank is filled with water.
 12. Restore the electric power supply to the water heater.

Diagnostic Code Chart

DIAGNOSTIC LIGHT	INDICATES	CORRECTIVE ACTION*
LIGHT ON	Normal operation	None
NO LIGHT	No power to control board or diagnostic light burned out	<ol style="list-style-type: none"> 1. Check for blown fuses or tripped breaker 2. Check power leads on control board with meter for 240 volts 3. If power is okay, replace control board
1 FLASH	Power on with no water in tank	<ol style="list-style-type: none"> 1. Add water and reset temperature control system. See "Reset Function" on page 10
2 FLASHES	Water temperature exceeded high limit	<ol style="list-style-type: none"> 1. Make sure upper and lower access doors and insulation are properly in place 2. Check element circuits for resistance of 5 - 25 ohms 3. Replace element if necessary and reset control system
3 FLASHES	Sensor failure	<ol style="list-style-type: none"> 1. Remove power 2. Check temperature sensor for open or shorted circuit 3. If no problem is found, replace sensors
4 FLASHES	Upper element circuit failure	<ol style="list-style-type: none"> 1. Remove power 2. Check element circuit for resistance of 5 - 25 ohms 3. Check wires at element and board for damage 4. If this 4 flashes condition continues, replace control board
5 FLASHES	Lower element circuit failure	<ol style="list-style-type: none"> 1. Remove power 2. Check element circuit for resistance of 5 - 25 ohms 3. Check wires at element and board for damage 4. If this 5 flashes condition continues, replace control board

*These instructions are brief and intended as guidance for a qualified service technician. If you lack the necessary skills to perform these procedures call **1-877-817-6750** for assistance.

Troubleshooting Chart

PROBLEM	POSSIBLE CAUSE(S)	CORRECTIVE ACTION
NO HOT WATER	<ol style="list-style-type: none"> 1. No power to heater 2. High temperature limit shut-down 3. Defective sensor 	<ol style="list-style-type: none"> 1. Refer to "No Light" of Diagnostic Code Chart 2. Refer to "2 Flashes" of Diagnostic Code Chart 3. Refer to "3 Flashes" of Diagnostic Code Chart
INSUFFICIENT HOT WATER	<ol style="list-style-type: none"> 1. Defective lower element 2. Temperature set too low 3. Sediment or lime in tank 4. Defective Dip Tube 5. Heater too small for job 6. Wrong piping connections 7. Leaking faucets 8. Wasted hot water 9. Long runs of exposed pipe 10. Hot water piping on outside wall 	<ol style="list-style-type: none"> 1. Refer to "5 Flashes" of Diagnostic Code Chart 2. Set temperature to desired setting 3. Drain. Determine if water treatment is needed 4. Replace Dip Tube 5. Check and install adequate water heater 6. Correct piping 7. Repair faucets 8. Advise customer 9. Insulate piping 10. Insulate piping
HIGH OPERATION COSTS	<ol style="list-style-type: none"> 1. Temperature set too high 2. Sediment or lime in tank 3. Heater too small for job 4. Leaking faucets 5. Wasted hot water 6. Long runs of exposed piping 7. Hot water piping in exposed wall 	<ol style="list-style-type: none"> 1. Lower temperature control or change to Energy Saver Mode 2. Drain. Flush-Provide water treatment if needed 3. Install adequate heater 4. Repair faucets 5. Advise customer 6. Insulate piping 7. Insulate piping
SLOW HOT WATER RECOVERY	<ol style="list-style-type: none"> 1. Upper element defective 2. Leaking faucets 	<ol style="list-style-type: none"> 1. Refer to "4 Flashes" of Diagnostic Code Chart 2. Repair faucets
DRIP FROM T&P VALVE	<ol style="list-style-type: none"> 1. Excessive water pressure 2. Closed system 3. Defective T & P valve 	<ol style="list-style-type: none"> 1. Use pressure reducing valve and pressure relief valve (See page 6) 2. See page 6, "Closed System/Thermal Expansion" 3. Replace T & P valve
WATER ODOR	<ol style="list-style-type: none"> 1. Sulfides in the water 	<ol style="list-style-type: none"> 1. See page 11, "Water Odor"

REPAIR PARTS ILLUSTRATION

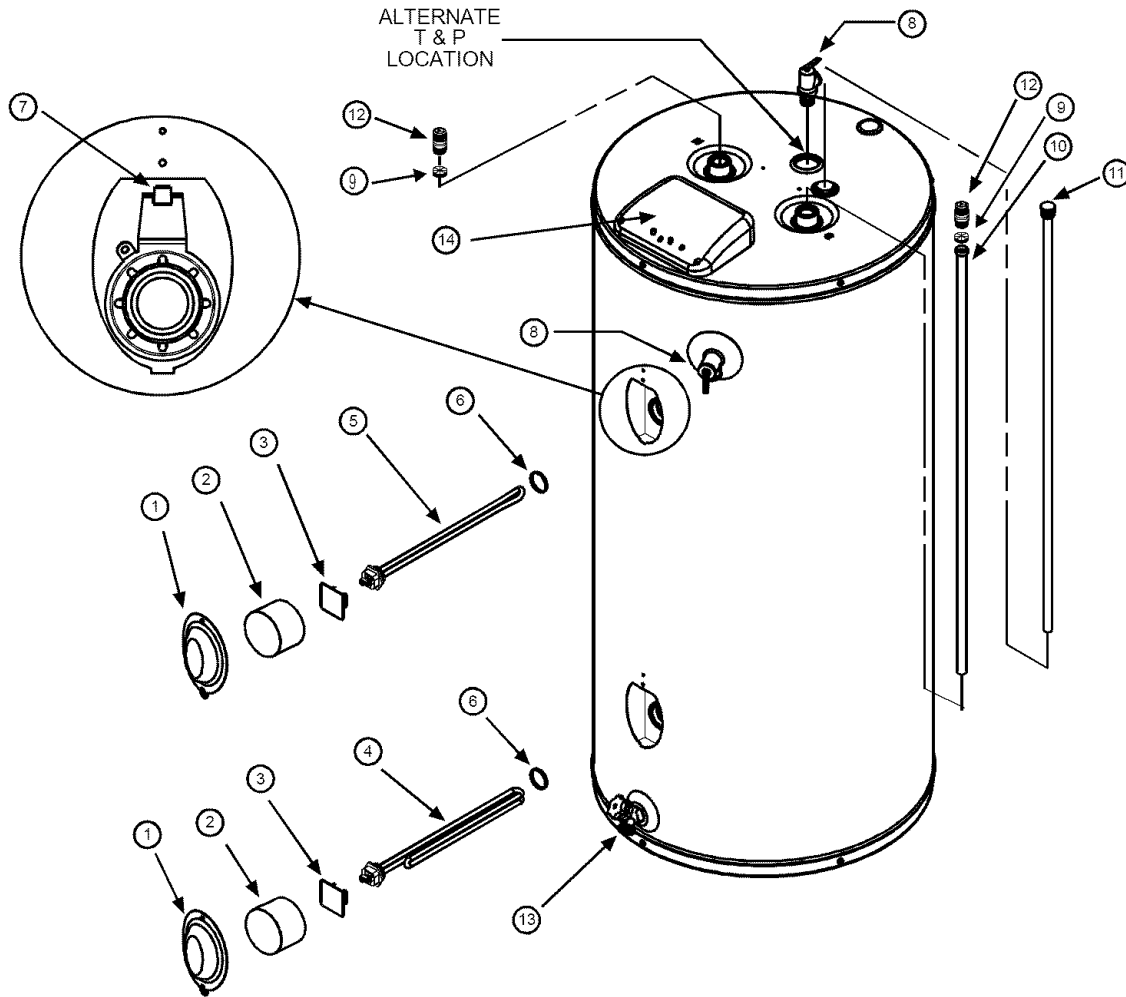

Repair Parts

Repair parts may be ordered through your plumber, local distributor, home improvement center, or by calling **1-877-817-6750**. When ordering repair parts always give the following information:

1. Model, serial and product number
2. Item number
3. Parts description

Repair Parts List

Legend

- ◆ Special anode rod (See page 11)
- Temperature and Pressure Relief Valve is required, but may not be factory installed.
- ▲ Specify element type when ordering

ITEM No.	PARTS DESCRIPTION
1	ACCESS DOORS
2	INSULATION PLUG
3	ELEMENT COVERS
4	LOWER ELEMENT▲
5	UPPER ELEMENT▲
6	ELEMENT GASKET
7	TEMPERATURE SENSOR
8	TEMPERATURE AND PRESSURE RELIEF VALVE■
9	HEAT TRAPS
10	DIP TUBE
11	ANODE ROD◆
12	NIPPLE
13	DRAIN VALVE
14	JUNCTION BOX