

SONY

Video Camera Recorder

Operating Instructions

Before operating the unit, please read this manual thoroughly, and retain it for future reference.

Owner's record

The model and serial numbers are located on the bottom. Record the model and serial numbers in the space provided below. Refer to these numbers whenever you call upon your Sony dealer regarding this product.

Model No. CCD- _____ Model No. AC- _____

Serial No. _____ Serial No. _____

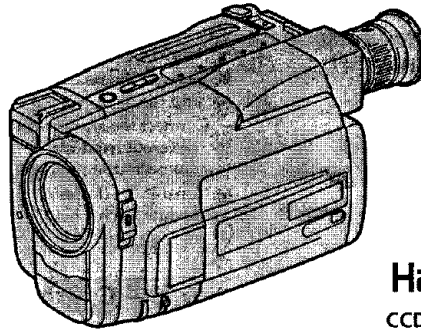

Handycam Vision™
CCD-TRV52

video 8

**CCD-TRV32/TRV52/TRV53/
TRV312/TRV512 8**

© 1997 by Sony Corporation

Welcome!

Congratulations on your purchase of this Sony Handycam Vision™ camcorder. With your Handycam Vision, you can capture life's precious moments with superior picture and sound quality. Your Handycam Vision is loaded with advanced features, but at the same time it is very easy to use. You will soon be producing home video that you can enjoy for years to come.

WARNING

To prevent fire or shock hazard, do not expose the unit to rain or moisture.

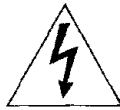
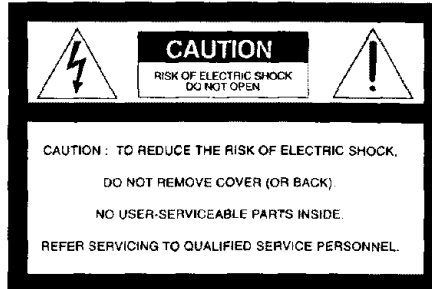

This symbol is intended to alert the user to the presence of uninsulated "dangerous voltage" within the product's enclosure that may be of sufficient magnitude to constitute a risk of electric shock to persons.



This symbol is intended to alert the user to the presence of important operating and maintenance (servicing) instructions in the literature accompanying the appliance.

RECYCLING NICKEL-CADMIUM BATTERIES



NICKEL-CADMIUM BATTERY. MUST BE DISPOSED OF PROPERLY.

Ni-Cd

Nickel-Cadmium batteries are recyclable. You can help preserve our environment by returning your unwanted batteries to your nearest Sony Service Center or Factory Service Center for collection, recycling or proper disposal.

Note: In some areas the disposal of nickel-cadmium batteries in household or business trash may be prohibited.

For the Sony Service Center nearest you call 1-800-222-SONY (United States only).
For the Factory Service Center nearest you call 416-499-SONY (Canada only).

Caution: Do not handle damaged or leaking nickel-cadmium batteries.

For the Customers in the U.S.A.

CAUTION

You are cautioned that any changes or modifications not expressly approved in this manual could void your authority to operate this equipment.

Note:

This equipment has been tested and found to comply with the limits for a Class B digital device, pursuant to Part 15 of the FCC Rules. These limits are designed to provide reasonable protection against harmful interference in a residential installation. This equipment generates, uses, and can radiate radio frequency energy and, if not installed and used in accordance with the instructions, may cause harmful interference to radio communications. However, there is no guarantee that interference will not occur in a particular installation. If this equipment does cause harmful interference to radio or television reception, which can be determined by turning the equipment off and on, the user is encouraged to try to correct the interference by one or more of the following measures:

- Reorient or relocate the receiving antenna.
- Increase the separation between the equipment and receiver.
- Connect the equipment into an outlet on a circuit different from that to which the receiver is connected.
- Consult the dealer or an experienced radio/TV technician for help.

For the Customers in CANADA

CAUTION

TO PREVENT ELECTRIC SHOCK, DO NOT USE THIS POLARIZED AC PLUG WITH AN EXTENSION CORD, RECEPTACLE OR OTHER OUTLET UNLESS THE BLADES CAN BE FULLY INSERTED TO PREVENT BLADE EXPOSURE.

Table of contents

Before you begin

Using this manual	4
Checking supplied accessories	6

Getting started

Charging and installing the battery pack	7
Inserting a cassette	10

Basic operations

Camera recording	11
Using the zoom feature	13
Selecting the start/stop mode	14
Shooting with the LCD screen	15
Letting the subject monitor the shot	16
Hints for better shooting	17
Checking the recorded picture	19
Playing back a tape	21
Searching for the end of the picture	23

Advanced operations

Using alternative power sources	24
Changing the mode settings	27
Recording with the date or time	30
Fade-in and fade-out	31
Enjoying picture effect	32
Using the wide mode function	34
Focusing manually	36
Using the PROGRAM AE function	37
Shooting with backlighting	38
Releasing the STEADY SHOT function	39
Superimposing a title	40
Making your own titles	43
Watching on a TV screen	45
Editing onto another tape	47

Additional information

Changing the lithium battery in the camcorder	48
Resetting the date and time	50
Playback modes	52
Tips for using the battery pack	53
Maintenance information and precautions	56
Using your camcorder abroad	61
Trouble check	62
Specifications	66
Identifying the parts	68
Warning indicators	75
Index	back cover

Before you begin

Using this manual

The instructions in this manual are for the five models listed below. Before you start reading this manual and operating the unit, check your model number by looking at the bottom of your camcorder. The CCD-TRV52 is the model used for illustration purposes. Otherwise, the model name is indicated in the illustrations. Any differences in operation are clearly indicated in the text, for example, "CCD-TRV52 only".

As you read through this manual, buttons and settings on the camcorder are shown in capital letters.

e.g. Set the POWER switch to CAMERA.

As indicated with  in the illustrations, you can hear the beep sound to confirm your operation.

Types of differences

CCD-	Audio	Viewfinder	LASER LINK
TRV32	Monaural	B/W	-
TRV52	Stereo	B/W	●
TRV53	Monaural	Color	●
TRV312	Monaural	B/W	-
TRV512	Stereo	B/W	●

Note on TV color systems

TV color systems differ from country to country.

To view your recordings on a TV, you need an NTSC system-based TV. When you want to use a PAL M system-based TV, you will need an NTSC/PAL M transcoder (as this is an NTSC system-based camcorder).

Precaution on copyright

Television programs, films, video tapes, and other materials may be copyrighted. Unauthorized recording of such materials may be contrary to the provision of the copyright laws.

Precautions on camcorder care

- The LCD screen and/or color viewfinder are manufactured using high-precision technology. However, there may be some tiny black points and/or bright points (red, blue or green in color) that constantly appear in the viewfinder or on the LCD screen. These points are normal in the manufacturing process and do not affect the recorded picture in any way. Over 99.99% are operational for effective use.
- Do not let the camcorder get wet. Keep the camcorder away from rain and sea water. It may cause a malfunction and sometimes the malfunction cannot be repaired. [a]
- Never leave the camcorder under temperatures above 140 °F (60 °C), such as in a car parked in the sun or under direct sunlight. [b]

Before you begin

[a]

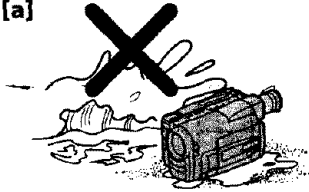

[b]

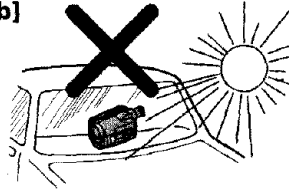

Checking supplied accessories

Check that the following accessories are supplied with your camcorder.

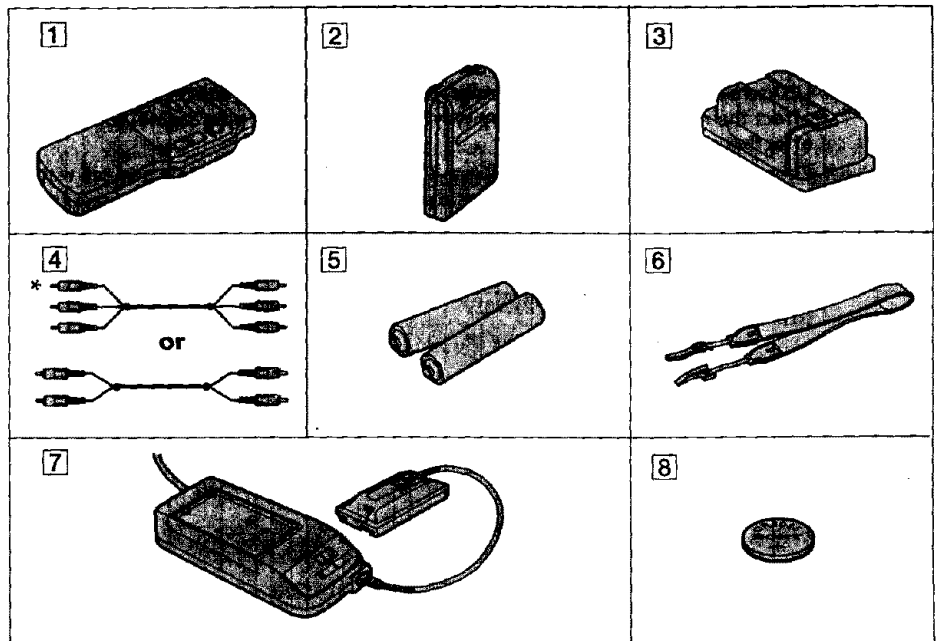

- 1 Wireless Remote Commander (1) (p. 22, 72)
- 2 NP-33 Battery Pack (1) (p. 7)
- 3 Battery case (1) (p. 25)
CCD-TRV32/TRV52/TRV53 only
- 4 A/V connecting cable (1) (p. 45)
* for stereo model
- 5 Size AA (R6) battery for Remote Commander (2) (p. 72)
- 6 Shoulder strap (1) (p. 71)
- 7 AC-V16/V16A AC power adaptor (1) (p. 7, 24)
- 8 CR2025 Lithium Battery (1) (p. 48)
Already installed in the camcorder.

Contents of the recording cannot be compensated if recording or playback is not made due to a malfunction of the camcorder, video tape, etc.

Getting started

Charging and installing the battery pack

Before using your camcorder, you first need to charge and install the battery pack. To charge the battery pack, use the supplied AC power adaptor.

Charging the battery pack

Charge the battery pack on a flat place without vibration.

- (1) Connect the AC power adaptor to a wall outlet.
- (2) Align the right side of the battery pack with the line on the AC power adaptor, then slide the battery pack in the direction of the arrow.
- (3) Set the selector to CHARGE. The CHARGE lamp (orange) lights up. Charging begins.

When charging is completed, the CHARGE lamp goes out. Unplug the unit from the wall outlet, and then remove the battery pack and install it on the camcorder.

Getting started

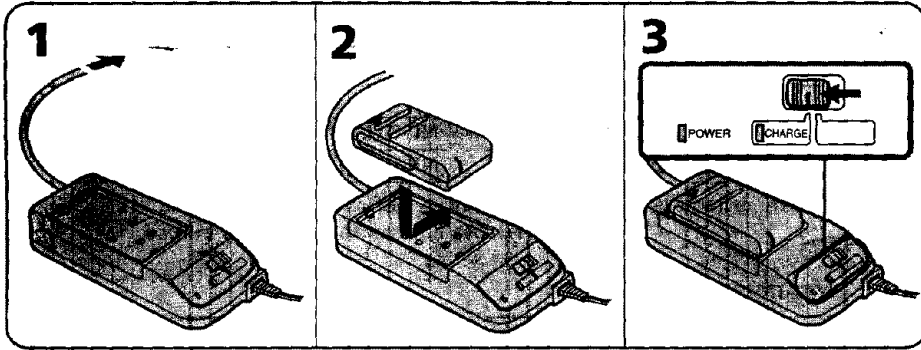

Charging time (in minutes)

Battery pack	Charging time*
NP-33 (supplied)	60
NP-60D	90
NP-C65	105

Battery pack	Charging time*
NP-68	125
NP-80/80D	190
NP-98/98D	215

* Approximate minutes to charge an empty battery pack using the supplied AC power adaptor (Lower temperatures require a longer charging time.)

Charging and installing the battery pack

Battery life (in minutes)

CCD-TRV32/TRV312

Battery pack	While recording ¹⁾		While playing back on LCD ³⁾
	LCD open ²⁾	LCD close	
NP-33 (supplied)	70 (40)	95 (50)	70
NP-60D	100 (55)	135 (75)	105
NP-C65	120 (65)	160 (90)	125

Battery pack	While recording ¹⁾		While playing back on LCD ³⁾
	LCD open ²⁾	LCD close	
NP-68	140(75)	185 (100)	145
NP-80/80D	200 (110)	270 (150)	210
NP-98/98D	225 (125)	315 (175)	240

CCD-TRV52/TRV512

Battery pack	While recording ¹⁾		While playing back on LCD ³⁾
	LCD open ²⁾	LCD close	
NP-33 (supplied)	60 (35)	90 (50)	65
NP-60D	95 (50)	135 (75)	95
NP-C65	105 (60)	155 (85)	110

Battery pack	While recording ¹⁾		While playing back on LCD ³⁾
	LCD open ²⁾	LCD close	
NP-68	135 (75)	180 (100)	135
NP-80/80D	190 (105)	255 (145)	190
NP-98/98D	215 (120)	305 (170)	220

CCD-TRV53

Battery pack	While recording ¹⁾		While playing back on LCD ³⁾
	LCD open ²⁾	LCD close	
NP-33 (supplied)	65 (35)	95 (50)	70
NP-60D	95 (50)	135 (75)	105
NP-C65	110 (60)	160 (90)	125

Battery pack	While recording ¹⁾		While playing back on LCD ³⁾
	LCD open ²⁾	LCD close	
NP-68	135 (75)	185 (100)	145
NP-80/80D	190 (105)	270 (150)	210
NP-98/98D	220 (120)	315 (175)	240

¹⁾ Approximate continuous recording time indoors. Figures in parentheses are approximate recording time when you repeat recording start/stop, zooming and turning the power on/off.

The actual battery life may be shorter.

²⁾ Approximate recording time when using the LCD screen. When using both the viewfinder and LCD screen, the battery life is shorter.

³⁾ Approximate continuous playback time indoors.

If you are recording or playing using the LCD screen with LCD B.L. set to BRIGHT in the menu system, the battery life is approximately 10% shorter.

Charging and installing the battery pack

To remove the battery pack

Slide the battery pack in the direction of the arrow.

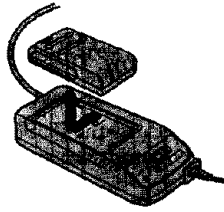

Notes on charging the battery pack

- The POWER lamp will remain lit for a while even if the battery pack is removed and the power cord is unplugged after charging the battery pack. This is normal.
- If the POWER lamp does not light, set the selector to VTR (DC OUT) and disconnect the power cord. After about one minute, reconnect the power cord and set the selector to CHARGE again.
- You cannot operate the camcorder using the AC power adaptor while charging the battery pack.

Getting started

Installing the battery pack

- (1) Insert the top of the battery pack into the top of the battery mounting surface.
- (2) Push the battery pack. Make sure that you hear clicks twice. Attach the battery pack to the camcorder securely.

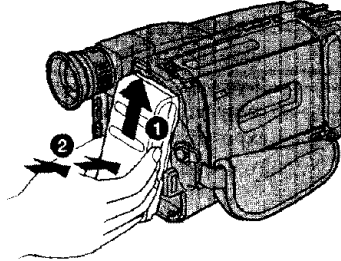

Note on the battery pack

Do not carry the camcorder by grasping the battery pack.

To remove the battery pack

Slide BATT, and then pull the lower part of the battery pack.

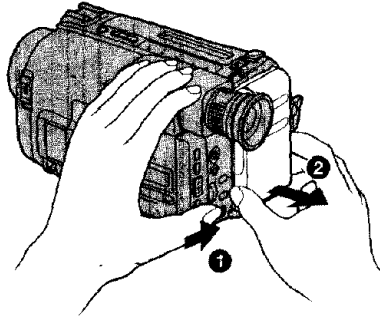

You can look at the demonstration of the functions available with this camcorder.
(p. 28)

Inserting a cassette

Make sure that a power source is installed.

- (1) While pressing the small blue button, slide EJECT in the direction of the arrow. The cassette compartment automatically opens.
- (2) Insert a cassette (not supplied) with the window facing out.
- (3) Press the PUSH mark on the cassette compartment to close it. The cassette compartment automatically closes.

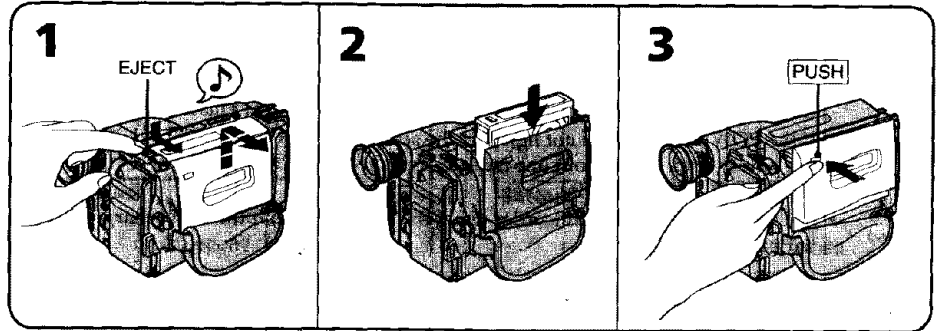



To eject the cassette

While pressing the small blue button, slide EJECT in the direction of the arrow.

To prevent accidental erasure

Slide the tab on the cassette to expose the red mark.

If you insert the cassette with the red mark exposed and close the cassette compartment, the beeps sound for a while. If you try to record with the red mark exposed, the  and  indicators flash, and you cannot record.

To re-record on this tape, slide the tab back out covering the red mark.



Camera recording

Make sure that a power source and a cassette is inserted and that the START/STOP MODE switch inside the LCD panel is set to .

When you use the camcorder for the first time, power on it and reset the date and time to your time (p. 50) before you start recording. The date is automatically recorded for 10 seconds after you start recording (**AUTO DATE** feature). This feature works only once a day.

Before you record one-time events, you may want to make a trial recording to make sure that you are using the camcorder correctly.

- (1) While pressing the small green button on the POWER switch, set it to CAMERA.
- (2) Turn STANDBY up. The "STBY" indicator appears in the viewfinder.
- (3) Press START/STOP. The camcorder starts recording and the "STBY" indicator changes to the "REC" indicator.

You can also select Recording mode, SP (standard play) mode or LP (long play) mode. Set REC MODE in the menu system according to the length of your planned recording before you start.

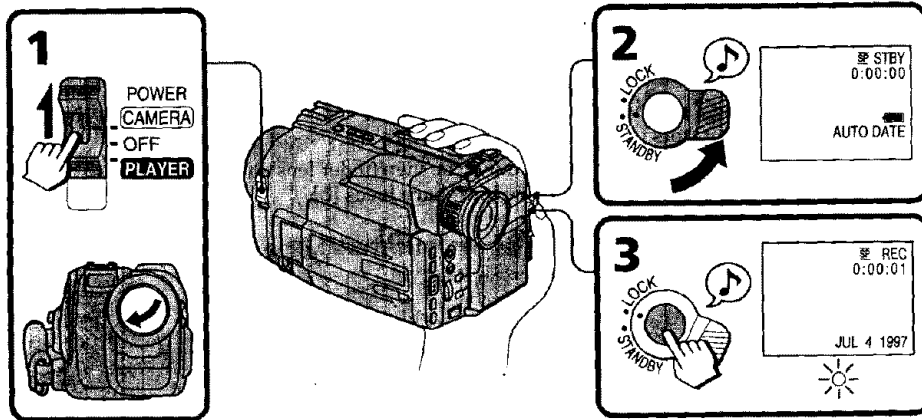

To stop recording momentarily [a]

Press START/STOP again. The "REC" indicator in the viewfinder changes to the "STBY" indicator (Standby mode).

To finish recording [b]

Press START/STOP. Turn STANDBY down, and set the POWER switch to OFF. Then, eject the cassette and remove the battery pack.

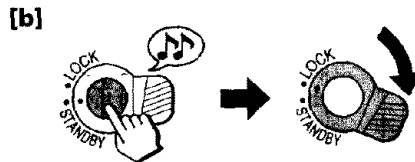
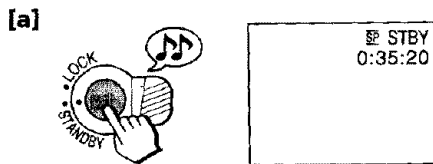

Note on standby mode

If you leave the camcorder for 5 minutes or more with a cassette inserted in Standby mode, the camcorder goes off automatically. This prevents wearing down the battery and wearing out the tape. To resume Standby mode, turn STANDBY down once and turn it up again. To start recording, press START/STOP.

Notes on the recording mode

- This camcorder records and plays back in SP (standard play) mode and in LP (long play) mode.
The playback quality in LP mode, however, will not be as good as that in SP mode.
- When you record a tape in LP mode on this camcorder, we recommend you to play the tape on this camcorder. When you play back the tape on other camcorders or VCRs, noise may occur on a picture or sound.
Noise may occur also when you play on this camcorder the tape recorded in LP mode on other camcorders or VCRs.

Note on recording

When you record from the beginning of the tape, run the tape for about 15 seconds before actual recording. This prevents the camcorder from missing any start-up scenes when you play back the tape.

To focus the viewfinder lens

If the viewfinder is not in focus at all or when you use the camcorder after someone else has used it, focus the viewfinder lens.

When using a monochrome viewfinder, turn the viewfinder lens adjustment ring so that the indicators in the viewfinder come into sharp focus [a].

When using a color viewfinder, move the viewfinder lens adjustment lever so that the indicators in the viewfinder come into sharp focus [b].

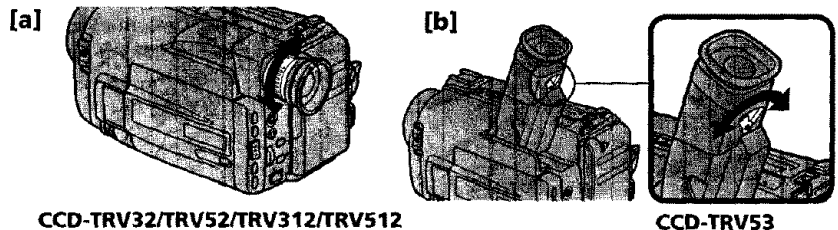

Notes on the tape counter

- The tape counter indicates the recording or playback time. Use it as a guide. There will be a time lag of several seconds from the actual time. To set the counter to zero, press COUNTER RESET inside the LCD panel.
- If the tape is recorded in SP and LP modes mixed, the tape counter shows incorrect recording time. When you intend to edit the tape using the tape counter as a guide, record in same (SP or LP) mode.

Note on beep sound

As indicated with *b* in the illustrations, a beep sounds when you turn the power on or when you start recording and two beeps sound when you stop recording, confirming the operation. Several beeps also sound as a warning of any unusual condition of the camcorder. Note that the beep sound is not recorded on the tape. If you do not want to hear the beep sound, set BEEP to OFF in the menu system.

Camera recording

Note on the AUTO DATE feature

The clock is set to East Coast Standard Time at the factory. You can reset the clock in the menu system.

The AUTO DATE feature shows the date automatically once a day. However, the date may automatically appear more than once a day when:

- you reset the date and time.
- you eject and insert the cassette again.
- you stop recording within 10 seconds.

Using the zoom feature

Zooming is a recording technique that lets you change the size of the subject in the scene. For more professional-looking recordings, use the zoom sparingly.

T side: for telephoto (subject appears closer)

W side: for wide-angle (subject appears farther away)

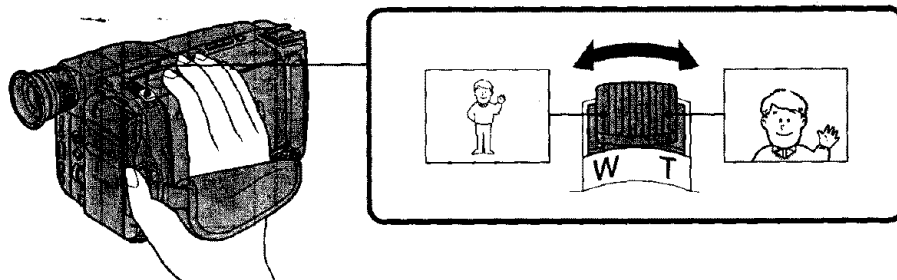

Zooming speed (Variable speed zooming)

Turn the power zoom lever fully for a high-speed zoom. Turn it lightly for a relatively slow zoom.

When you shoot a subject using a telephoto zoom

If you cannot get a sharp focus while in extreme telephoto zoom, move the power zoom lever to the "W" side until the focus is sharp.

You can shoot a subject that is at least 2.6 feet (about 80 cm) away from the lens surface in the telephoto position, or 1/2 inches (about 1 cm) in the wide-angle position.

Notes on digital zoom

- More than 15x zoom is performed digitally, and the picture quality deteriorates as you go toward the "T" side. If you do not want to use the digital zoom, set D ZOOM to OFF in the menu system.
- The right side [a] of the power zoom indicator shows the digital zooming zone, and the left side [b] shows the optical zooming zone. If you set D ZOOM to OFF, the right [a] zone disappears.

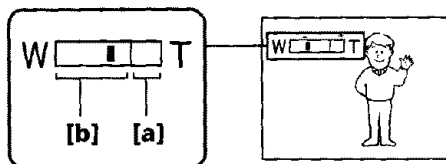

Camera recording

Selecting the start/stop mode

Your camcorder has two modes besides normal start/stop mode. These modes enable you to take a series of quick shots resulting in a lively video.

(1) While pressing PUSH OPEN, open the LCD panel.

(2) Set START/STOP MODE to the desired mode.

 : Recording starts when you press START/STOP, and stops when you press it again (normal mode).

 ANTI GROUND SHOOTING : The camcorder records only while you press down START/STOP so that you can avoid recording unnecessary scenes.

5SEC : When you press START/STOP, the camcorder records for 5 seconds and then stops automatically.

(3) Turn STANDBY up and press START/STOP. Recording starts.

If you selected **5SEC**, five dots appear in the viewfinder. The dots disappear at a rate of one per second as illustrated below.

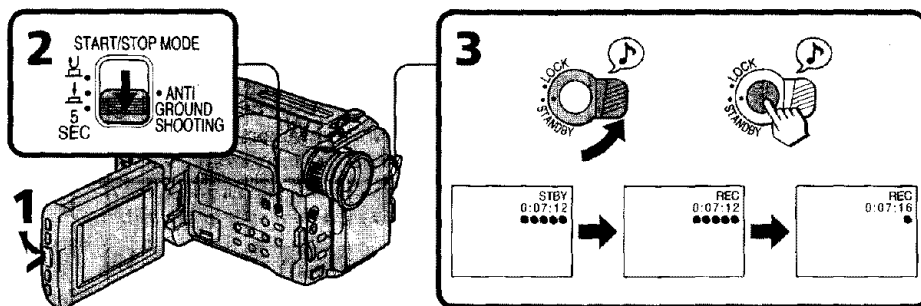

To extend the recording time in 5SEC mode

Press START/STOP again before all the dots disappear. Recording continues for about 5 seconds from the moment you press START/STOP.

Note on 5SEC recording

If you have turned off the indicators on the LCD screen, the dots do not appear.

Shooting with the LCD Screen

You can also record the picture while looking at the LCD screen.

When using the LCD screen, the viewfinder turns off automatically. You cannot monitor the sound from the speaker during recording.

- (1) While pressing PUSH OPEN, open the LCD panel.
- (2) Adjust the angle of the LCD panel.

The LCD panel moves about 90 degrees to this side and about 210 degrees to the other side.

To adjust the brightness of the LCD screen, press BRIGHT + or -.

The battery life is longer when the LCD panel is closed. Use the viewfinder instead of the LCD screen to save the battery power.

Basic operations

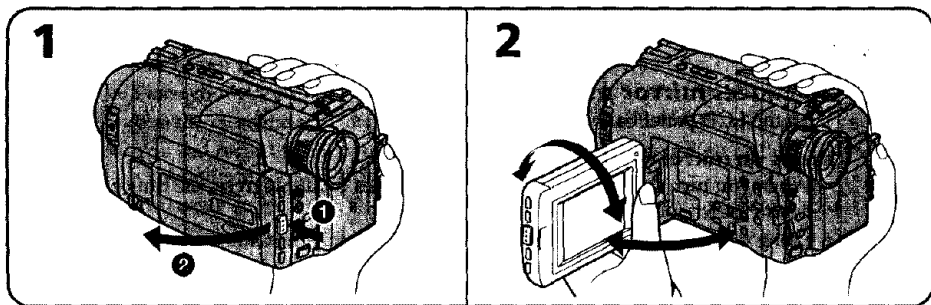

Notes on the LCD panel

- When closing the LCD panel, turn it vertically until it clicks [a].
- When turning the LCD panel, turn it always vertically; otherwise, the camcorder body may be damaged or the LCD panel may not close properly [b].
- Close the LCD panel completely when not in use.

[a]

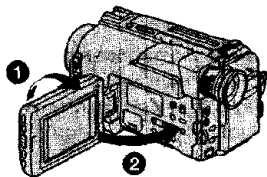

[b]

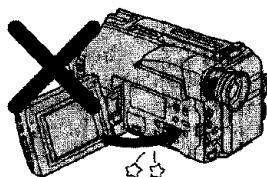

Letting the subject monitor the shot

You can turn the LCD panel over so that it faces the other way and you can let the subject monitor the shot while shooting with the viewfinder.

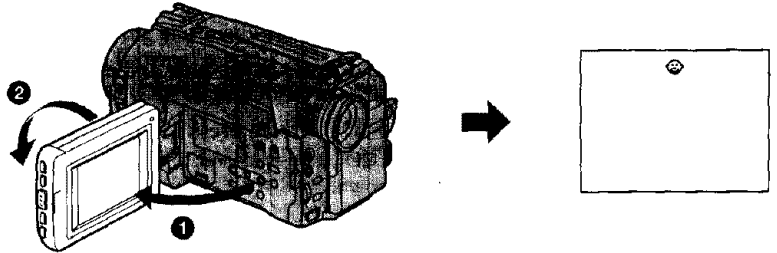

Turn the LCD panel vertically first until it clicks, then turn it over. The  indicator appears (**Mirror mode**) and the date and tape counter indicators disappear.



To cancel mirror mode

Turn the LCD panel back toward the viewfinder.

Notes on mirror mode

- When you turn the LCD panel about 135 degrees to 210 degrees, the camcorder enters mirror mode.
- Using the mirror mode, you can record yourself while watching yourself on the LCD [a].
- The picture on the LCD looks as a mirror-image while recording in mirror mode [b]. The STBY indicator appears as  and REC as . Some indicators may not appear in mirror mode.
- The date appears in reverse when the AUTO DATE feature is turned on. When recorded it will be normal.
- While recording in mirror mode, you cannot operate the following buttons: TITLE, DATE and TIME.
- The counter is displayed upside down in the display window.

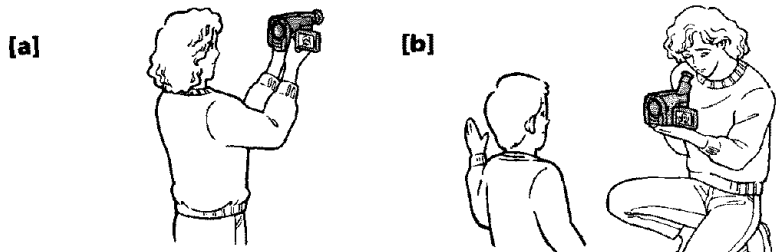

Hints for better shooting

For hand-held shots, you'll get better results by holding the camcorder according to the following suggestions:

- Hold the camcorder firmly and secure it with the grip strap so that you can easily manipulate the controls with your thumb.

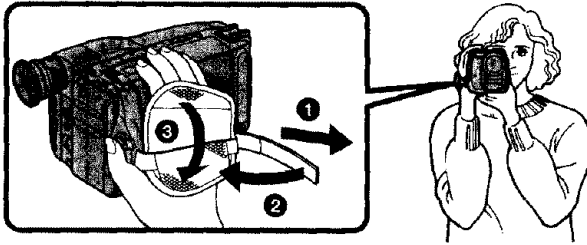

- Place your right elbow against your side.
- Place your left hand under the camcorder to support it.
- Place your eye firmly against the viewfinder eyecup.
- Use the viewfinder frame as a guide to determine the horizontal plane.
- You can record in a low position to get an interesting recording angle. Lift the viewfinder up for recording from a low position [a].
- You can also record in a low position or even in a high position using the LCD panel [b].

[a]



[b]



Place the camcorder on a flat surface or use a tripod

Try placing the camcorder on a table top or any other flat surface of suitable height. If you have a tripod for a still camera, you can also use it with the camcorder. When attaching a non-Sony tripod, make sure that the length of the tripod screw is less than 9/32 inches (6.5 mm). Otherwise, you cannot attach the tripod securely and the screw may damage the camcorder.

Hints for better shooting

Cautions on the viewfinder and the LCD

- Do not pick up the camcorder by the viewfinder or by the LCD panel [c].
- Do not place the camcorder so as to point the viewfinder or the LCD screen toward the sun. The inside of the viewfinder or the LCD panel may be damaged. Be careful when placing the camcorder under sunlight or by a window [d].

[c]

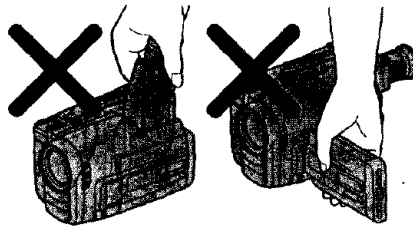

[d]

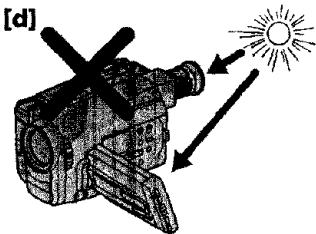

Note on the LCD screen

When you use the LCD screen outdoors in direct sunlight, the LCD screen may be difficult to see. If this happens, we recommend that you use the viewfinder.

Checking the recorded picture

Using EDITSEARCH, you can review the last recorded scene or check the recorded picture in the viewfinder. You can also review the picture on the LCD screen.

- (1) While pressing the small green button on the POWER switch, set it to CAMERA.
- (2) Turn STANDBY up.
- (3) Press the - (⊖) side of EDITSEARCH momentarily; the last few seconds of the recorded portion plays back (**Rec Review**). You can also monitor the sound from the speaker or by using an earphone (not supplied).
Hold down the - side of EDITSEARCH until the camcorder goes back to the scene you want. The last recorded portion is played back. To go forward, hold down the + side (**EditSearch**).

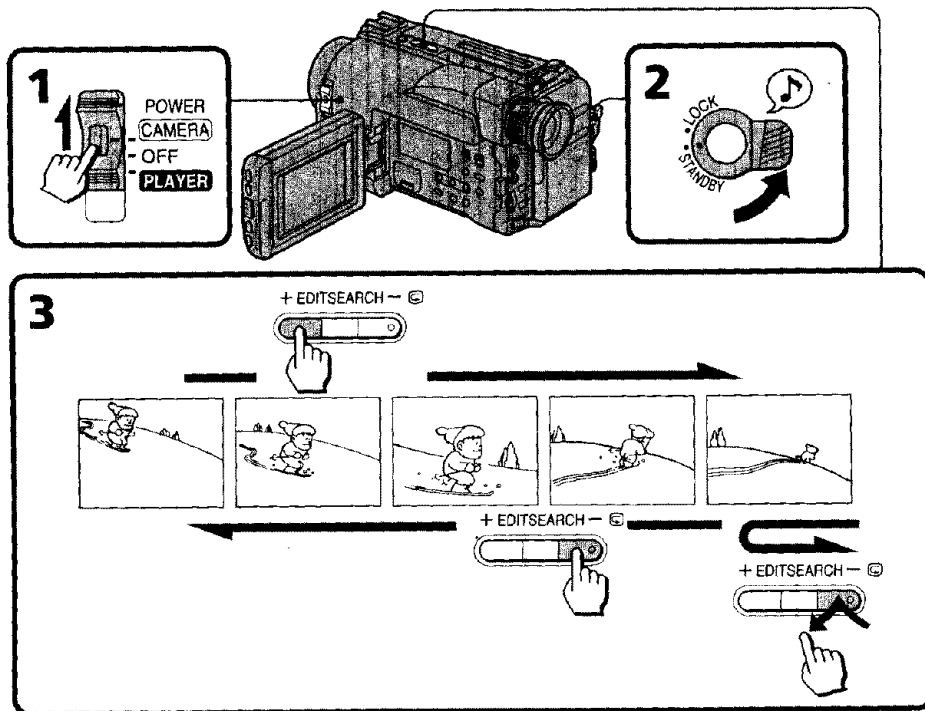

To stop playback
Release EDITSEARCH.

To go back to the last recorded point after edit search

Press END SEARCH. The last recorded point is played back for about 5 seconds if the tape was recorded in SP mode, or 10 seconds if the tape was recorded in LP mode, and stops. Note that this function does not work once you eject the cassette after you recorded in the tape.

To begin re-recording

Press START/STOP. Re-recording begins from the last recorded point or the point you released EDITSEARCH. Provided you do not eject the tape, the transition between the last scene you recorded and the next scene you record will be smooth.

Playing back a tape

You can monitor the playback picture on the LCD screen.

(1) While pressing the small green button on the POWER switch, set it to PLAYER.

(2) Insert the recorded tape with the window facing out.

(3) While pressing PUSH OPEN, open the LCD panel. Adjust the angle of the LCD panel or the brightness of the LCD screen if necessary.

(4) Press \blacktriangleright to start playback.

(5) Adjust the volume using VOLUME +/-.

You can also monitor on the TV screen after connecting the camcorder to the VCR or TV.

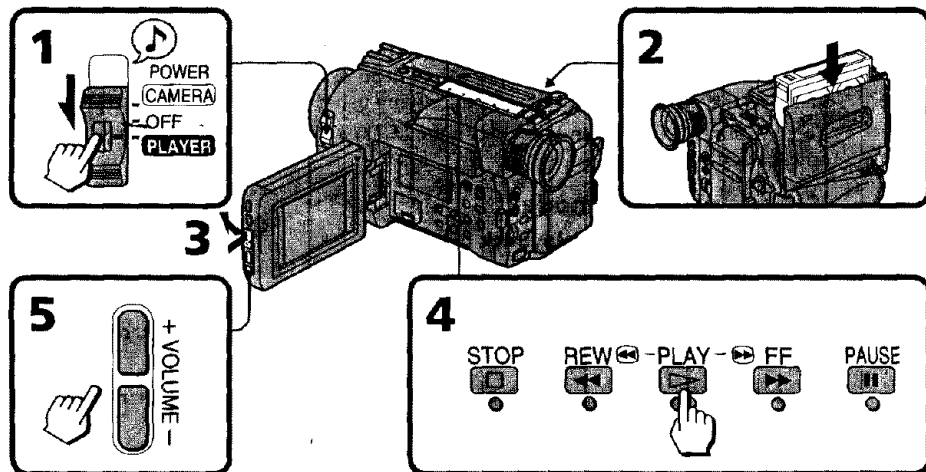

To stop playback, press \square .

To rewind the tape, press \blacktriangleleft .

To fast-forward the tape, press \blacktriangleright .

When watching on the LCD screen

You can turn the LCD panel over and move back to the camcorder with the LCD screen facing out [a]. You can adjust the angle of the LCD panel up to 20 degrees [b].

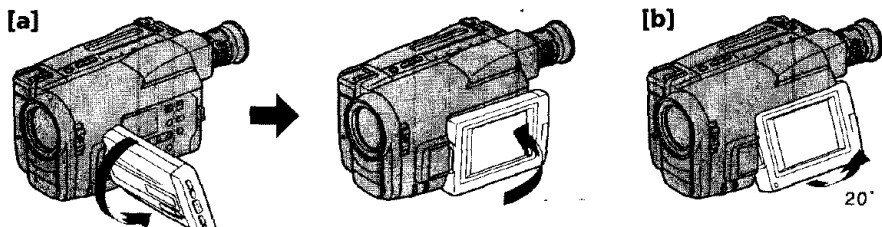

Using the Remote Commander

You can control playback using the supplied Remote Commander.



Before using the Remote Commander, insert the size AA (R6) batteries.

To erase the screen indicators

Press DISPLAY to erase the screen indicators on the LCD screen. To display the indicators, press again.

The indicators don't appear on the TV.

Using headphones or an earphone

Connect headphones (not supplied) to the  jack (CCD-TRV52/TRV512) or an earphone (not supplied) to the  jack (CCD-TRV32/TRV53/TRV312). You can adjust the volume using VOLUME.



To view the playback picture in the viewfinder

Close the LCD panel. The viewfinder turns on automatically. When using the viewfinder, you can monitor the sound only by using headphones or an earphone.



To view on the LCD screen again, open the LCD panel. The viewfinder turns off automatically.

Various playback modes



To view a still picture (playback pause)

Press  during playback. To resume playback, press  or .

To locate a scene (Picture Search)

Keep pressing  or  during playback. To resume normal playback, release the button.

To monitor the high-speed picture while advancing the tape or rewind (Skip Scan)

Keep pressing  while rewinding or  while advancing the tape.

To resume normal playback, press .

Notes on playback

- Streaks appear and the sound is muted in the various playback modes.
- When playback pause mode lasts for 5 minutes or more, the camcorder automatically enters stop mode.

Searching for the end of the picture

You can go to the end of the recorded portion after you record and play back the tape to make the transition between the last scene you recorded and the next scene smooth. The tape starts rewinding or fast-forwarding. Then, the last 5 seconds play back if the tape was recorded in SP mode, or the last 10 seconds play back if the tape was recorded in LP mode. Then the tape stops at the end of the recorded picture (**End Search**).

Note that End Search function does not work once you eject the cassette after you recorded in the tape.

- (1) While pressing PUSH OPEN, open the LCD panel.
- (2) Press END SEARCH.

This function works when the POWER switch is set to either CAMERA or PLAYER.

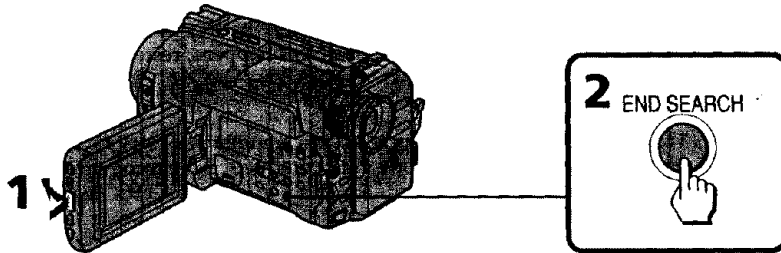

Using alternative power sources

You can choose any of the following power sources for your camcorder: battery pack, the house current, alkaline battery and 12/24 V car battery. Choose the appropriate power source depending on where you want to use your camcorder.

Place	Power source	Accessory to be used
Indoors	House current	Supplied AC power adaptor
Outdoor	Battery pack	Battery pack (Ni-Cd type)
	Size AA (LR6) alkaline batteries	Battery case (CCD-TRV32/TRV52/TRV53 only)
In the car	12 V or 24 V car battery	Sony DC pack DCP-77

Note on power sources

Disconnecting the power source or removing the battery pack during recording or playback may damage the inserted tape. If this happens, restore the power supply again immediately.



This mark indicates that this product is a genuine accessory for Sony video product. When purchasing Sony video products, Sony recommends that you purchase accessories with this "GENUINE VIDEO ACCESSORIES" mark.

Using the house current

To use the supplied AC power adaptor:

- (1) Connect the power cord to a wall outlet. Insert the top of the connecting plate of the AC power adaptor into the top of the battery mounting surface. Push the connecting plate so that it attaches firmly. Make sure that you hear clicks twice.
- (2) Set the selector to VTR (DC OUT).

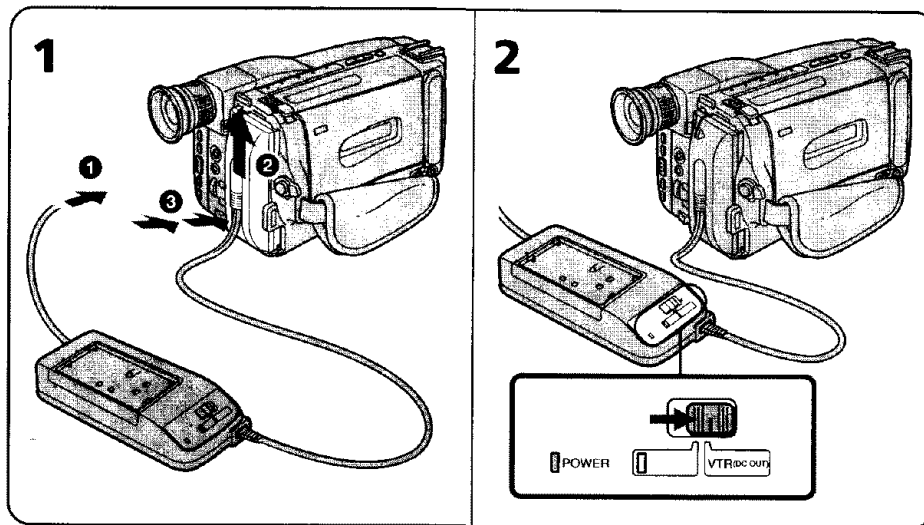

Using alternative power sources

WARNING

The power cord must only be changed at qualified service shop.

PRECAUTIONS

The set is not disconnected from the AC power source (mains) as long as it is connected to the wall outlet, even if the set itself has been turned off.

Notes on the POWER lamp

- The POWER lamp will remain lit for a while even if the unit is unplugged after use. This is normal.
- If the POWER lamp does not light, set the selector to VTR (DC OUT) and disconnect the power cord. After about one minute, reconnect the power cord.

To remove the adaptor

The adaptor is removed in the same way as the battery pack.

Using the alkaline batteries

– CCD-TRV32/TRV52/TRV53 only

Use the battery case (supplied) and six size AA (LR6) Sony alkaline batteries (not supplied).

- (1) Remove the battery holder from the battery case.
- (2) Insert six new alkaline batteries by matching the + and – on the batteries to the diagram on the battery holder.
- (3) Insert the battery holder with the alkaline batteries.
- (4) Install the battery case with the alkaline batteries to the battery mounting surface of the camcorder in the same way as the battery pack.

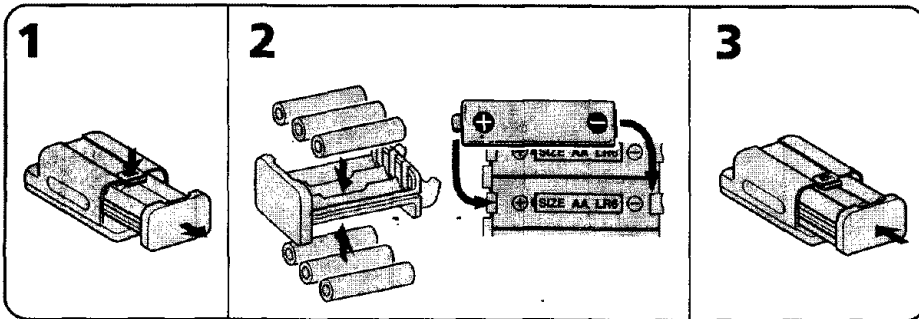

Using alternative power sources

Battery life (in minutes)

Using Sony alkaline batteries at 77 °F (25 °C)

Model	While recording		While playing back on LCD
	LCD open	LCD close	
CCD-TRV32	110 (55)	165 (85)	120
CCD-TRV52	100 (50)	160 (80)	100
CCD-TRV53	110 (55)	165 (85)	120

Approximate continuous recording time indoors. Figures in parentheses are approximate recording time when you repeat recording start/stop, zooming and turning the power on/off.

The actual battery life may be shorter.

Notes

- You may not use the battery case in cold environment.
- The above battery lives are estimates. The battery life may be shorter depending on the storage condition of the battery before being purchased and temperature.

To remove the battery case

The battery case is removed in the same way as the battery pack.

Using a car battery

Use Sony DCP-77 DC pack (not supplied). Connect the cord of the DC pack to the cigarette lighter socket of the car (12 V or 24 V). Connect the DC pack to the battery mounting surface of the camcorder.

To remove the DC pack

The DC pack is removed in the same way as the battery pack.

Changing the mode settings

You can change the mode settings to further enjoy the features and functions of the camcorder.

- (1) While pressing PUSH OPEN, open the LCD panel.
- (2) Press MENU to display the menu.
- (3) Turn the control dial to select the desired item, and press the dial.
- (4) Turn the control dial to select the desired mode, and press the dial.
- (5) Press MENU to erase the menu display.

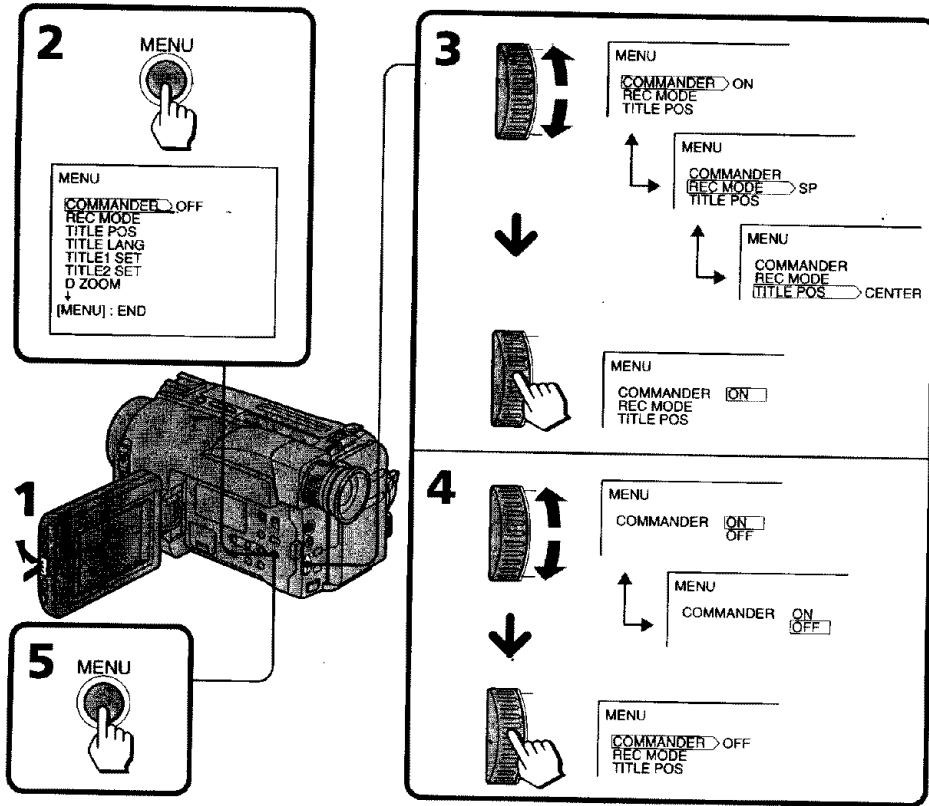

Advanced operations

Selecting the mode setting of each item

Items for both CAMERA and PLAYER modes

COMMANDER <ON/OFF>

- Select ON when using the supplied Remote Commander for the camcorder.
- Select OFF when not using the Remote Commander.

BEEP* <ON/OFF>

- Select ON so that beeps sound when you start/stop recording, etc.
- Select OFF when you do not want to hear the beep sound.

LCD B.L. * <BRT NORMAL/BRIGHT>

- If you select BRT NORMAL, the battery life becomes about 10% longer than it is when you select BRIGHT.
- Select BRIGHT to make the LCD screen brighter when shooting/playing back outdoors.

Items for CAMERA mode only

REC MODE* <SP/LP>

- Select SP to record a tape in SP (standard play) mode.
- Select LP to record a tape in LP (long play) mode.

TITLE POS* <CENTER/BOTTOM>

- Select CENTER to center the title in the picture.
- Select BOTTOM to position the title at the bottom of the picture.

TITLE LANG* <ENGLISH/FRANÇAIS/ESPAÑOL/PORTUGUÊS>

Select the language of the preset titles.

TITLE1 SET*/TITLE2 SET*

Store your own titles.

D ZOOM* <ON/OFF>

- Select ON to activate digital zooming.
- Select OFF to not use the digital zoom. The camcorder goes back to 15x zoom.

REC LAMP* <ON/OFF>

- Select OFF when you do not want the camera recording/battery lamp at the front of the unit to light up.
- Normally select ON.

AUTO DATE* <ON/OFF>

- Select ON to record the date for 10 seconds after recording has started.
- Select OFF to not record the date.

CLOCK SET*

Reset the date or time.

DEMO MODE* <ON/OFF>

- Select ON to make the demonstration appear.
- Select OFF to make the demonstration not appear.

Item for **PLAYER mode only**

HiFi SOUND <STEREO/1/2> (CCD-TRV52/TRV512 only)

- Normally select STEREO.
- Select 1 or 2 to play back a dual sound track tape.

* These settings are retained even when the battery is removed, as long as the lithium battery is in place.

Notes on DEMO MODE

- DEMO MODE is set to STBY at the factory and the demonstration starts about 10 minutes after you set the POWER switch to CAMERA without inserting a cassette. Note that you cannot select STBY of DEMO MODE in the menu system.
- You cannot select DEMO MODE when a cassette is inserted in the camcorder.
- If you insert a cassette during the demonstration, the demonstration stops. You can start recording as usual. DEMO MODE automatically returns to STBY.

To look at the demonstration at once

Eject the cassette, if inserted. Select ON of DEMO MODE. Erase the menu display. The demonstration will begin.

When you turn off the camcorder once, DEMO MODE automatically returns to STBY.

Recording with the date or time

Before you start recording or during recording, press DATE or TIME inside the LCD panel. You can record the date or time displayed on the LCD screen or in the viewfinder with the picture. You cannot record the date and time at the same time. Except for the date or time indicator, no indicator is recorded.

The clock is set to East Coast Standard Time at the factory. You can reset the clock in the menu system.

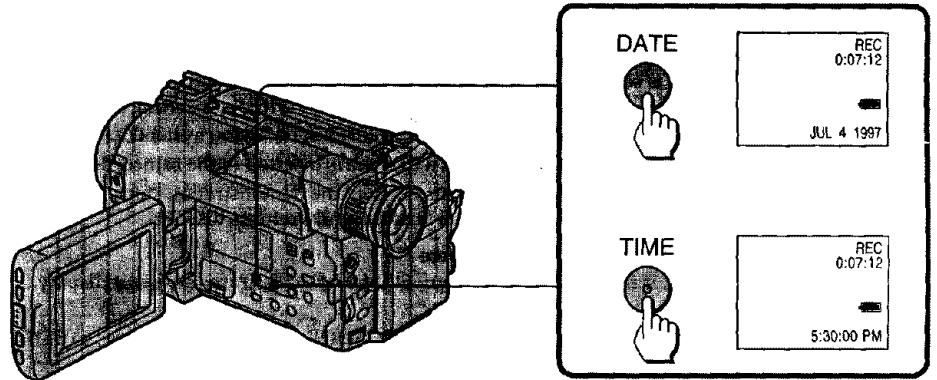

To stop recording with the date or time

Press DATE or TIME again. The date or time indicator disappears. The recording continues.

Note

You cannot superimpose a title during recording the date or time.

Fade-in and fade-out

You can fade in or out to give your recording a professional appearance. When fading in, the picture gradually fades in from black while the sound increases. When fading out, the picture gradually fades to black while the sound decreases.

When fading in [a]

- (1) While the camcorder is in Standby mode, press FADER. The FADER indicator starts flashing.
- (2) Press START/STOP to start recording. The FADER indicator stops flashing.

When fading out [b]

- (1) During recording, press FADER. The FADER indicator starts flashing.
- (2) Press START/STOP to stop recording. The FADER indicator stops flashing, and then recording stops.

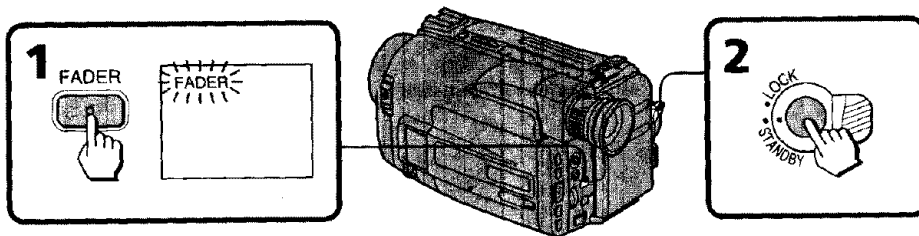

To cancel the fade-in/fade-out function

Before pressing START/STOP, press FADER to turn off the FADER indicator.

When the date/time or title is displayed

The date/time or title does not fade in or fade out.

When the START/STOP MODE switch is set to $\frac{1}{2}$ or 5SEC

You cannot use the fade-in/fade-out function.

Enjoying picture effect

Selecting picture effect

You can make pictures like those of television with the Picture Effect function.

[a]



[b]



[c]



MOSAIC [a]

The picture is mosaic.

SOLARIZE [b]

The light intensity is more clear, and the picture looks like a painting.

B&W

The picture is monochrome (black and white).

SEPIA

The picture is sepia.

NEG. ART [c]

The color of the picture is reversed.

Enjoying picture effect

Enjoying Picture Effect Function

- (1) While pressing PUSH OPEN, open the LCD panel.
- (2) While the camcorder is in Standby mode, press PICTURE EFFECT to select the desired Picture Effect mode.

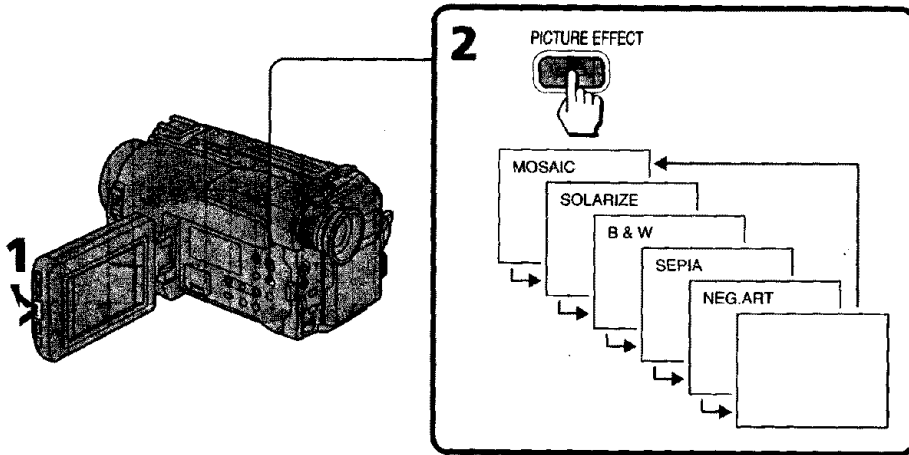

Advanced operations

Returning to normal mode

Press PICTURE EFFECT until the Picture Effect indicator disappears.

Note on the picture effect

When you turn the power off, the camcorder returns automatically to normal mode.

Using the wide mode function

Selecting the desired mode

You can record a cinemalike picture (CINEMA) or a 16:9 wide picture to watch on the 16:9 wide-screen TV (16:9FULL).

CINEMA

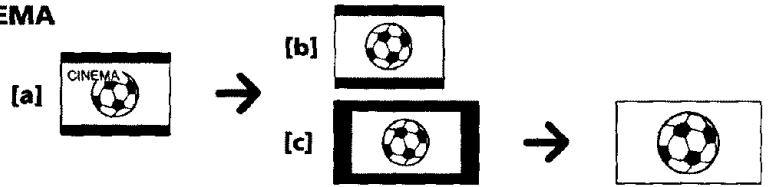

16:9FULL

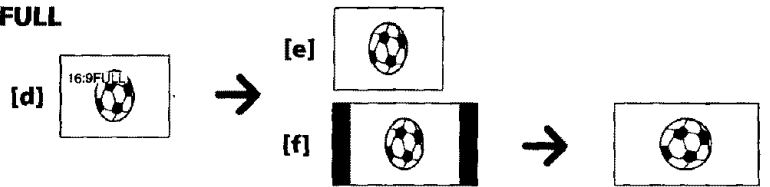

CINEMA

Black bands appear at the top and the bottom of the screen. The viewfinder or the LCD screen **[a]** and a normal TV screen **[b]** look wide. You can also watch the picture without black bands on a wide-screen TV **[c]**.

16:9FULL

The picture in the viewfinder or on the LCD screen **[d]** or on a normal TV **[e]** is horizontally compressed. You can watch the picture of normal images on a wide-screen TV **[f]**.

Using the wide mode function

Using the wide mode function

- (1) While pressing PUSH OPEN, open the LCD panel.
- (2) While the camcorder is in Standby mode, press 16:9 WIDE repeatedly so that the desired mode indicator appears.

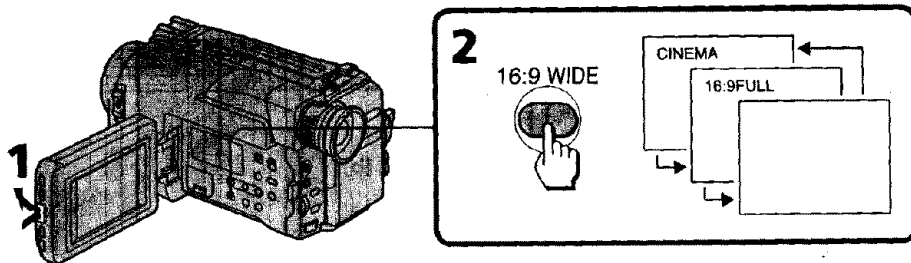

Advanced operations

To cancel wide mode

Press 16:9 WIDE repeatedly until the wide mode indicator disappears.

To watch the tape recorded in wide mode

To watch the tape recorded in CINEMA mode, set the screen mode of the wide-screen TV to zoom mode. To watch the tape recorded in 16:9FULL mode, set it to full mode. For details, refer to the instruction manual of your TV.

Note that the picture recorded in 16:9FULL mode looks compressed on a normal TV.

Notes on wide mode

- You cannot cancel the wide mode during recording.
- If wide mode is set to 16:9FULL, the SteadyShot function does not work and the  indicator flashes.
- When you record in 16:9FULL mode, the date or time indicator will be widened on the wide-screen TV.
- If you dub a tape, the tape is copied in the same mode as the original recording.
- The wide mode is cancelled automatically 5 minutes after you remove the power source.

Focusing manually

When to use manual focus

In the following cases you should obtain better results by adjusting the focus manually.

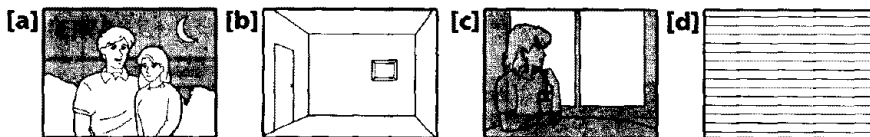

- Insufficient light **[a]**
- Subjects with little contrast — walls, sky, etc. **[b]**
- Too much brightness behind the subject **[c]**
- Horizontal stripes **[d]**
- Subjects through frosted glass
- Subjects beyond nets, etc.
- Bright subject or subject reflecting light
- Shooting a stationary subject when using a tripod

Focusing manually

When focusing manually, first focus in telephoto before recording, and then reset the shot length.

(1) Set FOCUS to MANUAL. The  indicator appears.

(2) Turn the focus dial to focus on the subject.

Turn to the NEAR side to focus on a nearer object.

Turn to the FAR side to focus on a farther object.

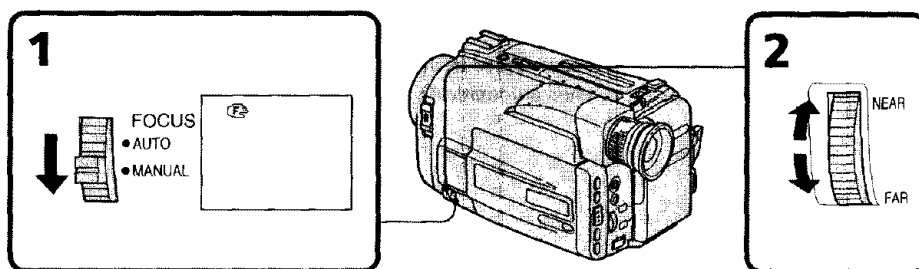

To return to the autofocus mode

Set FOCUS to AUTO. The  indicator goes out.

Shooting in relatively dark places

Shoot at wide-angle after focusing in the telephoto position.

Using the PROGRAM AE function

You can select from three PROGRAM AE (Auto Exposure) modes to suit your shooting situation. When you use PROGRAM AE, you can capture high-speed action or night views.

Selecting the best mode

Select the best mode by using the following examples.



Sports mode

- Outdoor sports scenes such as football, tennis, golf or skiing
- A landscape in a moving car

High-speed shutter mode

- A golf swing or a tennis match in fine weather with the ball captured clearly
- Playing back certain scenes with high-speed movements in clear, sharp picture

Twilight mode

- Recording night views, neon signs or fireworks

Advanced operations

Using the PROGRAM AE function

While the camcorder is in Standby mode, press PROGRAM AE until the desired PROGRAM AE indicator appears.

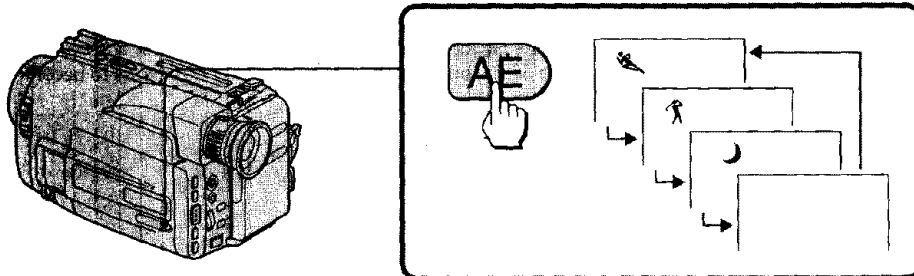

Returning to automatic mode

Press PROGRAM AE until the PROGRAM AE indicator disappears.

Note on shutter speed

The shutter speed in each PROGRAM AE mode is as follows:

Sports mode – between 1/60 to 1/500

High-speed shutter mode – 1/4000

Twilight mode – 1/60

AUTO mode – 1/60 (or 1/100 when the Steady Shot is on)

Shooting with backlighting

When you shoot a subject with the light source behind the subject or a subject with a light background, use the BACK LIGHT function.

Press BACK LIGHT. The  indicator appears in the viewfinder or on the LCD screen.

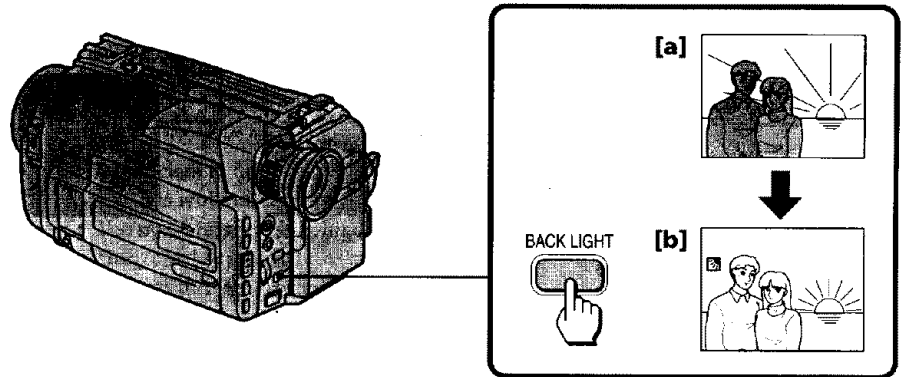

[a] Subject is too dark because of backlight.

[b] Subject becomes bright with backlight compensation.

After shooting

Be sure to release this adjustment condition by pressing BACK LIGHT again. The  indicator disappears. Otherwise, the picture will be too bright under normal lighting condition.

This function is also effective under following conditions:

- On snow e.g. at the ski resort
- At the beach under strong sunshine
- A subject with a light source nearby or a mirror reflecting light
- A white subject against a white background. Especially when you shoot a person wearing shiny clothes made of silk or synthetic fiber, his or her face tends to become dark if you do not use this function.

Releasing the STEADY SHOT function

When you shoot, the  indicator appears. This indicates that the SteadyShot function is working and the camcorder compensates for camera-shake.

You can release the SteadyShot function when you do not need to use the SteadyShot function. Do not use the SteadyShot function when shooting a stationary object with a tripod.

(1) While pressing PUSH OPEN, open the LCD panel.

(2) Set STEADY SHOT to OFF. The  indicator goes off.

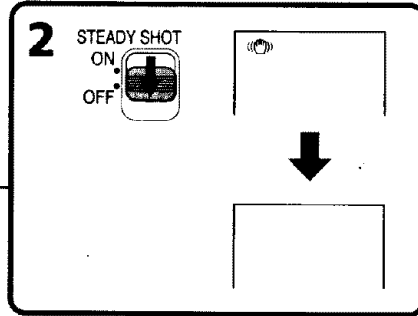
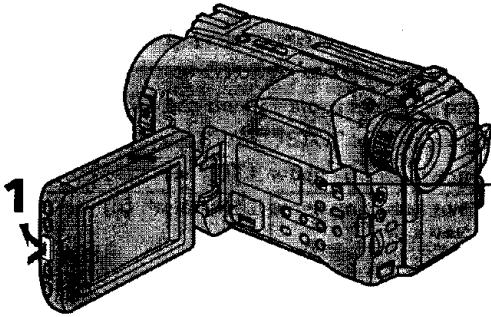

Advanced operations

To activate the SteadyShot function again

Set STEADY SHOT to ON.

Notes on the SteadyShot

- The SteadyShot will not correct excessive camera-shake.
- When you switch the SteadyShot function on or off, the exposure may fluctuate.
- When you record in 16:9FULL mode, the SteadyShot function does not work and the  indicator flashes.

Superimposing a title

You can select from eight preset titles and two titles you made to superimpose it on the picture during recording. Each time you press TITLE, the preset titles appear one by one.

Selecting the language

- (1) While pressing PUSH OPEN, open the LCD panel.
- (2) Press MENU to display the menu.
- (3) Turn the control dial to select TITLE LANG, and press the dial.
- (4) Turn the control dial to select the desired language, and press the dial.
- (5) Press MENU to erase the menu display.

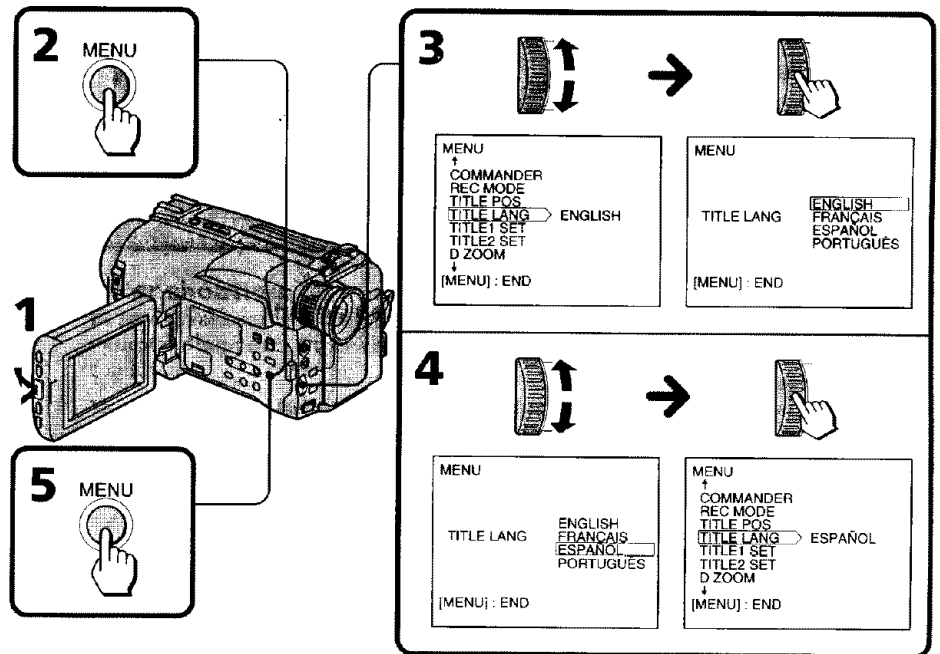

Superimposing titles

To superimpose from the beginning

- (1) Set the POWER switch to CAMERA.
- (2) Turn STANDBY up.
- (3) While pressing PUSH OPEN, open the LCD panel.
- (4) Press TITLE repeatedly until the desired title appears. The title flashes.
- (5) Press START/STOP to start recording.
- (6) Press TITLE when you want to turn off the title.

To superimpose on the way of recording

- (1) Press TITLE repeatedly until the desired title appears. The title flashes.
- (2) When the title stops flashing, press TITLE. The title disappears.
- (3) Press START/STOP to start recording.
- (4) Press TITLE when you want superimpose the title.
- (5) Press TITLE when you want to turn off the title.

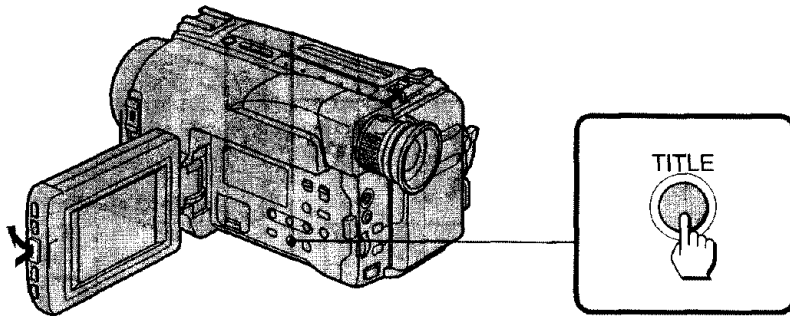

Titles cycle as follows

Original title 1 → Original title 2 → HELLO! → HAPPY BIRTHDAY → HAPPY HOLIDAYS → CONGRATULATIONS! → OUR SWEET BABY → WEDDING → VACATION → THE END

When you press TITLE with "THE END" displayed, the titles disappear. When you press TITLE once again, the titles begin from "HELLO!" or your original title.

The titles are displayed in the language you selected in the menu system.

If you have not stored any original titles

The titles begin from "HELLO!".

Notes on titles

- You cannot select a title during recording.
- You cannot record a title and the date at the same time.
- You cannot record a title and the time at the same time.
- While the menu is displayed, the titles are not recorded.

Superimposing a title

To select the title position

- (1) Press MENU to display the menu on the LCD screen.
- (2) Turn the control dial to select TITLE POS, then press the dial.
- (3) Turn the control dial to select CENTER [a] or BOTTOM [b], then press the dial.
- (4) Press MENU to erase the menu display.



Making your own titles

You can make two titles of up to 22 characters each, and store them in memory. We recommend to eject the cassette before you begin so that the power is not turned off on the way.

- (1) While pressing PUSH OPEN, open the LCD panel.
- (2) While the camcorder is in Standby mode, press MENU to display the menu.
- (3) Turn the control dial to select TITLE1 SET or TITLE2 SET, then press the dial.
- (4) Turn the control dial to select the desired character, then press the dial.
- (5) Repeat step 4 until you finish the title.
- (6) Turn the dial to select ↵, then press the dial. The title is stored in memory.
- (7) Press MENU to erase the menu display.

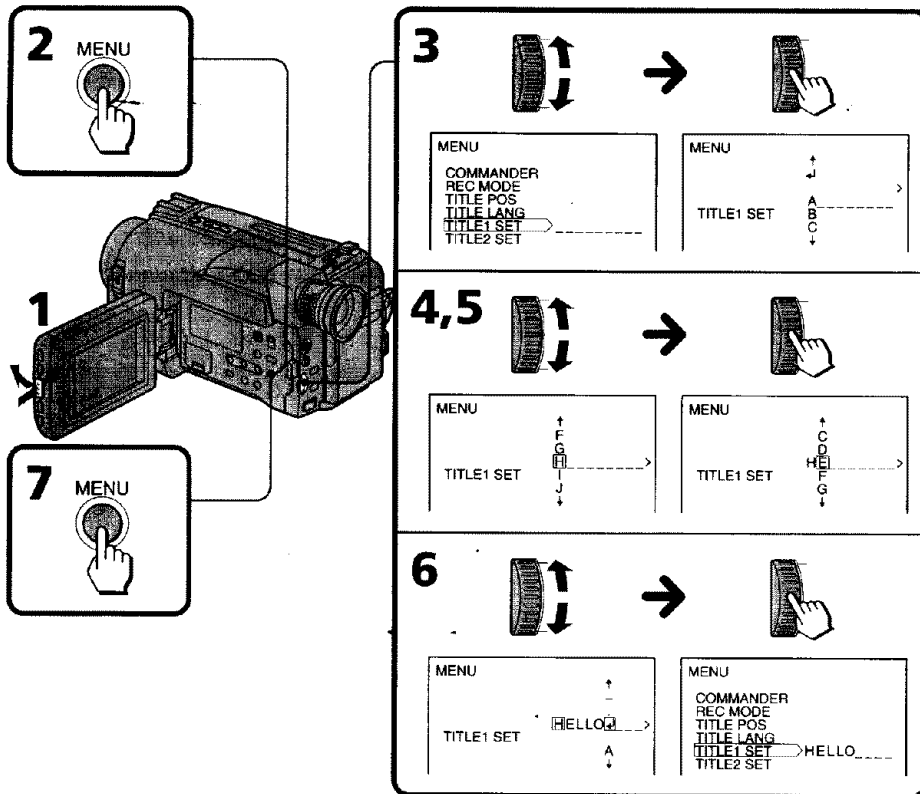

Advanced operations

Making your own titles

To erase the title you have made

Press MENU, select the title you want to erase, and press the dial. Select ◀ at the leftmost character, then press the dial.

Do not select the blank to erase a character. Otherwise, the blank is stored as a title in memory.

To change the title you have made

In step 3, select TITLE1 SET or TITLE2 SET, depending on which title you want to change, then press the dial. Select the desired characters again.

If you enter 22 characters in step 5

The title is stored immediately (and you can skip step 6).

If it takes more than 5 minutes to make a title with a cassette inserted

If the Standby mode lasts for more than 5 minutes with a cassette inserted, the power is turned off automatically.

If the power is turned off while you are making a title, set the POWER switch to OFF once, then to CAMERA. The title you have made remains stored in memory.

Advancing the characters rapidly

Keep pressing the dial.

Making a blank

Select a blank. It is counted as a character.

Watching on a TV screen

Connect the camcorder to your VCR or TV to watch the playback picture on the TV screen. When monitoring the playback picture by connecting the camcorder to your TV, we recommend you to use the house current for the power source.

While playing back on a TV screen, close the LCD panel. Otherwise, picture distortion may occur.

If your TV is already connected to a VCR

Open the jack cover and connect the camcorder to the LINE IN inputs on the VCR by using the supplied A/V connecting cable. Set the input selector on the VCR to LINE. Set the TV/VCR selector on the TV to VCR.

Connecting CCD-TRV52/TRV512

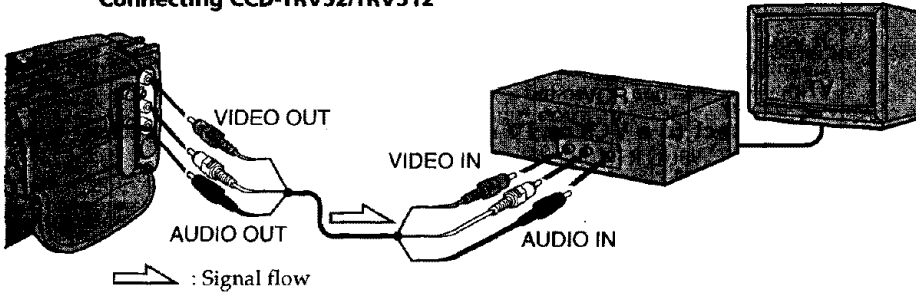

Connecting CCD-TRV32/TRV312/TRV53

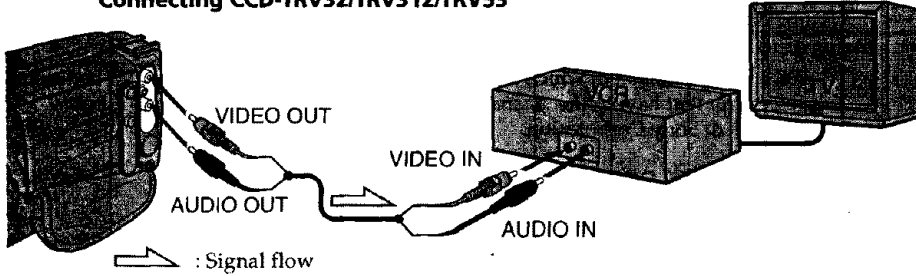

If you connect directly to TV

Connect the camcorder to the inputs on the TV by using the supplied A/V connecting cable. Set the TV/VCR selector on the TV to VCR.

Connecting CCD-TRV52/TRV512

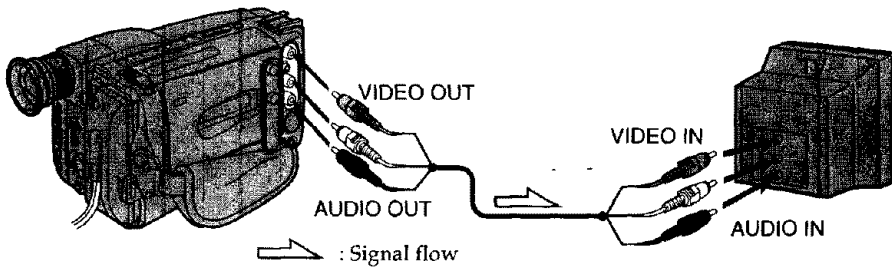

Watching on a TV screen

Connecting CCD-TRV32/TRV312/TRV53

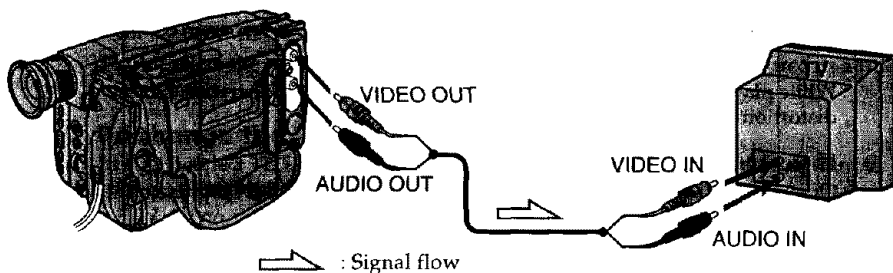

If your VCR or TV is a monaural type (CCD-TRV52/TRV512 only)

Connect only the white plug for audio on both the camcorder and the VCR or the TV. With this connection, the sound is monaural even on the stereo model.

To connect to a VCR or TV without Video/Audio input jacks

Use the RFU-95UC RFU adaptor (not supplied).

Using the AV cordless IR receiver – LASER LINK

– CCD-TRV52/TRV512/TRV53 only

Once you connect the AV cordless IR receiver (not supplied) having the **L** mark to your TV or VCR, you can easily view the picture on your TV. For details, refer to the instruction manual of the AV cordless IR receiver.

LASER LINK is a system which transmits and receives a picture and sound between video equipment having the **L** mark by using infrared rays. LASER LINK is a trademark of Sony Corporation.

To play back on a TV

- (1) Set the POWER switch on the camcorder to PLAYER.
- (2) After connecting your TV and AV cordless IR receiver, set the POWER switch on the AV cordless IR receiver to ON.
- (3) Turn the TV on and set the TV/VCR selector on the TV to VCR.
- (4) Press LASER LINK. The lamp of LASER LINK lights.
- (5) Press \blacktriangleright on the camcorder to start playback.
- (6) Adjust the angle and direction of both the camcorder and AV cordless IR receiver.

Editing onto another tape

You can create your own video program by editing with any other 8 mm, Hi8, Hi8i, Hi8V, Hi8V Hi8, VHS, VHS S-VHS, VHS VHSC, S-VHS S-VHSC, Betamax or ED Beta ED Betamax VCR that has video/audio inputs.

Turn down the volume of the camcorder while editing. Otherwise, picture distortion may occur.

After connecting the camcorder to the VCR,

- (1) Set the POWER switch to PLAYER.
- (2) Insert a blank tape (or a tape you want to record over) into the VCR and insert your recorded tape into the camcorder.
- (3) Play back the recorded tape on the camcorder until you locate the point where you want to start editing, then press **II** to put the camcorder in playback pause mode.
- (4) On the VCR, locate the recording start point and put the VCR in recording pause mode.
- (5) Press **II** on the camcorder and VCR simultaneously to start editing.

Advanced operations

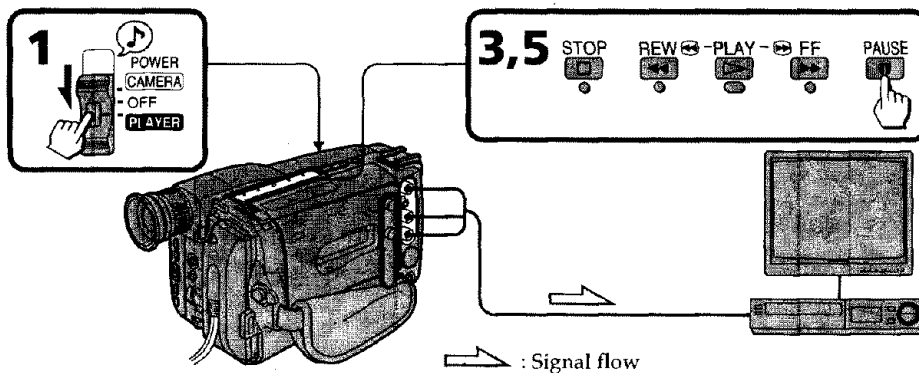

To edit more scenes

Repeat steps 3 to 5.

To stop editing

Press **II** on both the camcorder and VCR.

Additional information

Changing the lithium battery in the camcorder

Your camcorder is supplied with a lithium battery installed. When the battery becomes weak or dead, the  indicator flashes in the viewfinder or on the LCD screen for about 5 seconds when you set the POWER switch to CAMERA. In this case, **replace the battery with a Sony CR2025 or Duracell DL-2025 lithium battery. Use of any other battery may present a risk of fire or explosion.** Discard used batteries according to the manufacturer's instructions.

The lithium battery for the camcorder lasts for about one year under normal operation. (The lithium battery that comes installed at the factory may not last one year.)

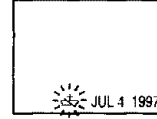

Notes on lithium battery

- Keep the lithium battery out of the reach of children. Should the battery be swallowed, immediately consult a doctor.
- Wipe the battery with a dry cloth to assure a good contact.
- Do not hold the battery with metallic tweezers, otherwise a short-circuit may occur.
- The lithium battery has positive (+) side and negative (-) side as illustrated. **Be sure to insert the lithium battery with the positive side facing out.**

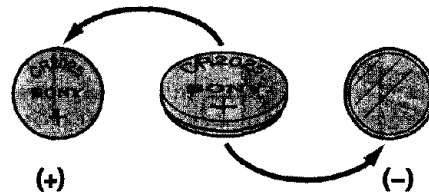

WARNING

The battery may explode if mistreated. Do not recharge, disassemble, or dispose of in fire.

Changing the lithium battery in the camcorder

Changing the lithium battery

When replacing the lithium battery, keep the battery pack or other power source attached. Otherwise, you will need to reset the date and time .

- (1) While pressing PUSH OPEN, open the LCD panel.
- (2) Open the lid of the lithium battery compartment.
- (3) Push the battery in once and pull it out from the holder.
- (4) Install the new lithium battery with the positive (+) side facing out.
- (5) Close the lid.

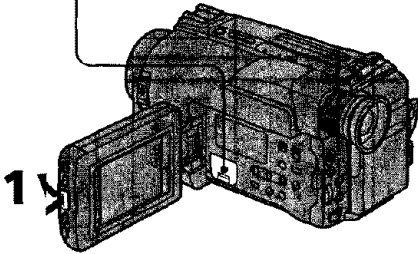
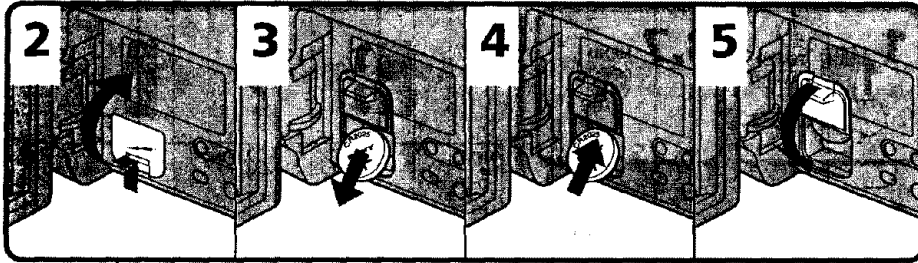

Additional information

Resetting the date and time

You can reset the date and time in the menu system.

- (1) Set the POWER switch to CAMERA.
- (2) While pressing PUSH OPEN, open the LCD panel.
- (3) Press MENU to display the menu.
- (4) Turn the control dial to select CLOCK SET, then press the dial.
- (5) Turn the control dial to select the desired year, then press the dial.
- (6) Set the month, day, hour, and minutes by turning the control dial and pressing the dial.
- (7) Press MENU to erase the menu display.

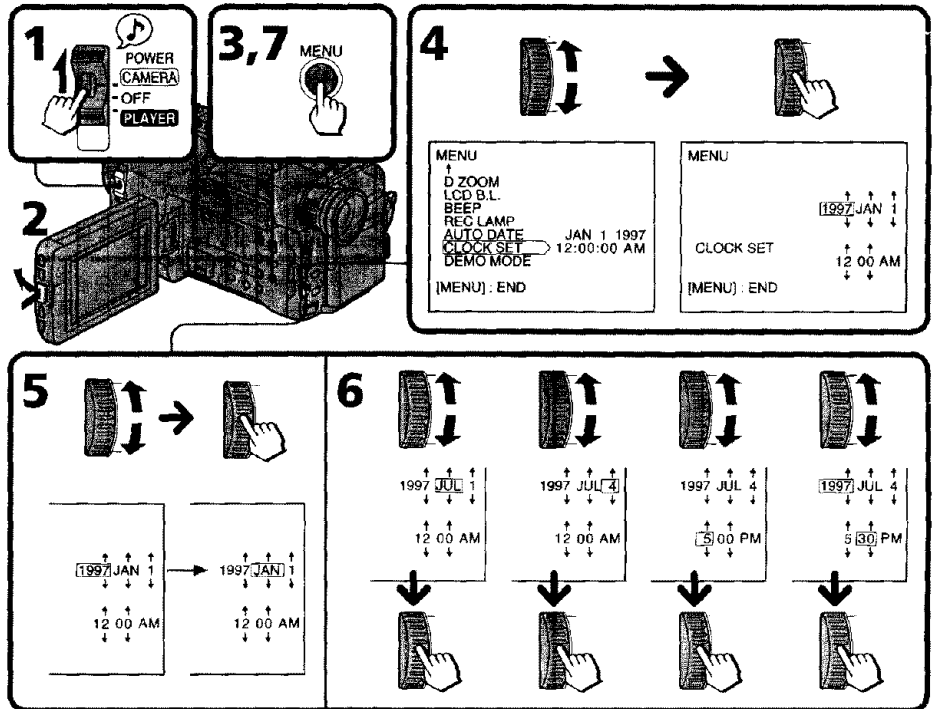

To correct the date and time setting

Repeat steps 5 and 6.

To check the date and time

Press DATE to display the date indicator. Press TIME to display the time indicator. When you press the same button again, the indicator goes out.

Resetting the date and time

The year indicator changes as follows:

1997 → 1998 2025
└──────────────────┘

Note on the time indicator

The internal clock of this camcorder operates on a 12-hour cycle.

- 12:00 AM stands for midnight.
- 12:00 PM stands for noon.

Additional information

Playback modes

The playback mode (SP/LP) is selected automatically according to the format in which the tape has been recorded. The quality of the recorded picture in LP mode, however, will not be as good as that in SP mode.

Note on AFM HiFi stereo (CCD-TRV52/TRV512 only)

When you play back a tape, the sound will be in monaural if:

- You record the tape using the camcorder, then play it back on an AFM HiFi monaural video recorder/player.
- You record the tape on an AFM HiFi monaural video recorder, then play it back on this camcorder.

Foreign 8 mm video

You may not play back tapes recorded on a different TV color system. Because the TV color systems differ from country to country, you may not be able to play back foreign pre-recorded tapes. Refer to the list of "Using your camcorder abroad" to check the TV color system of foreign countries.

Tips for using the battery pack

This section shows you how you can get the most out of your battery pack.

Preparing the battery pack

Always carry additional batteries

Have sufficient battery pack power to do 2 to 3 times as much recording as you have planned.

Battery life is shorter in cold environment

Battery efficiency is decreased, and the battery will be used up more quickly, if you are recording in cold environment.

To save battery power

Turn the STANDBY switch on the camcorder down when not recording to save battery power.

A smooth transition between scenes can be made even if recording is stopped and started again. While positioning the subject, selecting an angle, or looking through the viewfinder lens or on the LCD screen, the lens moves automatically and the battery is used. The battery is also used when a cassette is inserted or removed.

Additional information

When to replace the battery

While you are using your camcorder, the remaining battery indicator decreases gradually as battery power is used up.



When the remaining battery indicator reaches the lowest point, the  indicator appears and starts flashing.

When the  indicator changes from slow flashing to rapid flashing while you are recording, set the POWER switch to OFF on the camcorder and replace the battery pack. Leave the tape in the camcorder to obtain smooth transition between scenes before and after the battery pack has been replaced.

Note on the remaining battery indicator

The remaining battery indicator of the camcorder may indicate a different remaining capacity from that of the battery pack with its own indicator (not supplied). The indicator on the battery pack is more accurate.

Notes on the rechargeable battery pack

CAUTION

Never leave the battery pack in temperatures above 140 °F (60 °C), such as in a car parked in the sun or under direct sunlight.

The battery heats up

During charging or recording, the battery pack heats up. This is caused by energy that has been generated and a chemical change that has occurred inside the battery pack. This is not cause for concern and is normal.

Battery pack care

- Remove the battery pack from the camcorder after using it, and keep it in a cool place. When the battery pack is installed to the camcorder, a small amount of current flows to the camcorder even if the POWER switch is set to OFF. This shortens battery life.
- The battery pack is always discharging even when it is not in use after charging. Therefore, you should charge the battery right before using the camcorder.

How to use the switch on the battery pack

When the switch is supplied with the battery pack [a], you can use it to find whether the battery pack is charged or not. Set the switch to the "no mark" position when charging is completed. Set the switch to the "red.mark" position when the battery is used up (or in whichever direction you want to remind yourself).

[a]

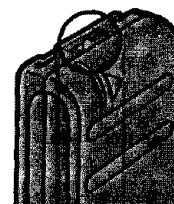

The life of the battery pack

If the battery indicator flashes rapidly just after turning on the camcorder with a fully charged battery pack, the battery pack should be replaced with a new fully charged one.

Charging temperature

You should charge batteries at temperatures from 50 °F to 86 °F (from 10 °C to 30 °C). Lower temperatures require a longer charging time.

Sony batteries are recommended

Use of non-Sony batteries may damage your Handycam camcorder.

Notes on charging

A brand-new battery

A brand-new battery pack is not charged. Before using the battery pack, charge it completely.

After long storage

Recharge the battery pack after a long period of storage. If the battery pack is charged fully but not used for a long time (about one year), it becomes discharged. Charge it again, but in this case the battery life will be shorter than normal. After several charging and discharging cycles, the battery life will recover its original capacity.

Tips for using the battery pack

Notes on the terminals

If the terminals (metal parts on the back) are not clean, the battery charge duration will be shortened.

When the terminals are not clean or when the battery pack has not been used for a long time, repeatedly install and remove the battery pack a few times. This improves the contact condition. Also, wipe the + and - terminals with a soft cloth or paper.

Be Sure to Observe the Following

- To prevent an accident caused by a short circuit, do not allow metal objects such as a necklace to touch the battery terminals. When carrying the battery pack, attach to the terminal cover. [b]
- Keep the battery pack away from fire.
- Keep the battery pack dry.
- Do not open or try to disassemble the battery pack.
- Do not expose the battery pack to any mechanical shock.

[b]

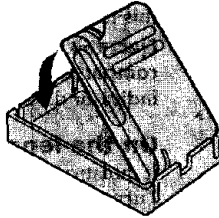

Additional information

Notes on the battery case



– CCD-TRV32/TRV52/TRV53 only

- Use only with the alkaline batteries. You cannot use the battery case with manganese batteries or size AA (LR6) rechargeable NiCd batteries.
- Using with Sony alkaline batteries is preferable.
- Battery life is remarkably shorter in a cold environment (lower than 50 °F/10 °C).
- Keep the metal part clean. If it gets dirty, wipe it with a soft cloth.
- Do not disassemble or try to disassemble the battery case.
- Do not expose the battery case to any mechanical shock.
- During recording, the battery case heats up. This is not cause for concern.
- Prevent the electrode in the battery case from coming in contact with a metal object.
- If you will not use the battery case for a long time, detach the battery case from the camcorder and remove the batteries from the battery case.

Moisture condensation

If the camcorder is brought directly from a cold place to a warm place, moisture may condense inside the camcorder, on the surface of the tape, or on the lens. In this condition, the tape may stick to the head drum and be damaged or the camcorder may not operate correctly. To prevent possible damage under these circumstances, the camcorder is furnished with moisture sensors. Please take the following precautions.

Inside the camcorder

When the  and  indicators flash, moisture has condensed inside the camcorder. If this happens, no other functions except for tape ejection will work.

Eject the tape, turn off the camcorder and leave it with the cassette compartment open for at least one hour. The camcorder can be used again if the  indicator does not appear when the power is turned on again.

On the lens

If moisture condenses on the lens, no indicator appears, but the picture becomes dim. Turn off the power and do not use the camcorder for about one hour.

How to prevent moisture condensation

When bringing the camcorder from a cold place to a warm place, put the camcorder in a plastic bag and allow it to adapt to room conditions over a period of time.

- (1) Be sure to tightly seal the plastic bag containing the camcorder.
- (2) Remove the bag when the air temperature inside it has reached the temperature surrounding it (after about one hour).

Maintenance information and precautions

Video head cleaning

To ensure normal recording and clear pictures, clean the video heads. When  appears in CAMERA mode or playback pictures are "noisy" or hardly visible, the video heads may be dirty.



[a]



[b]

[a] Slightly dirty

[b] Dirty

If this happens, clean the video heads with the Sony V8-25CLH cleaning cassette (not supplied). After checking the picture, if it is still "noisy", repeat the cleaning. (Do not repeat cleaning more than 5 times in one session.)

Caution

Do not use a commercially available wet-type cleaning cassette. It may damage the video heads.

Note

If the V8-25CLH cleaning cassette is not available in your area, consult your nearest Sony dealer.

Additional Information

Removing dust from inside the viewfinder

- CCD-TRV32/TRV52/TRV312/TRV512 only

- (1) Remove the screw with a screwdriver (not supplied). Then, while sliding the RELEASE knob, turn the eyecup in the direction of the arrow and pull it out.
- (2) Clean the surface with a commercially available blower.

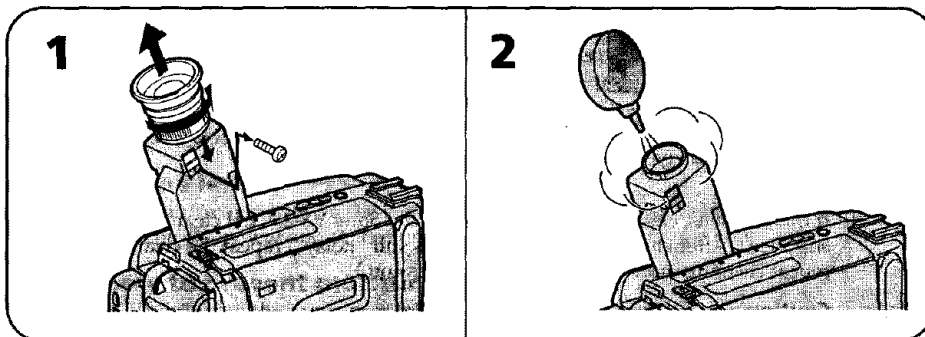

To reattach the eyecup

- (1) Align the groove on the eyecup with the • mark on the barrel.
- (2) Turn the eyecup in the direction of the arrow.
- (3) Replace the screw.

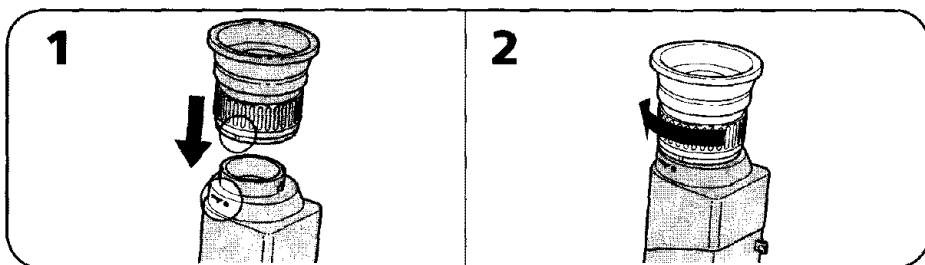

Caution

Do not remove any other screws. You may remove only the screw to remove the eyecup.

Camcorder operation

- Operate the camcorder using 6.0 V (battery pack), or 7.5 V (AC power adaptor).
- For DC or AC operation, use only the recommended accessories.
- Should any solid object or liquid fall into the casing, unplug the camcorder and have it checked by your nearest Sony dealer before operating it any further.
- Avoid rough handling or mechanical shock. Be particularly careful of the lens.
- Keep the POWER switch set to OFF when not using the camcorder.
- Do not wrap up the camcorder and operate it since heat may build up internally.
- Keep the camcorder away from strong magnetic fields or mechanical vibration.
- Do not push the LCD screen.
- If the camcorder is used in a cold place, a residual image may appear on the LCD screen.
This is not a malfunction.
- While using the camcorder, the back of the LCD screen may heat up. This is not a malfunction.

On handling tapes

Do not insert anything in the small holes on the rear of the cassette. These holes are used to sense the type of tape, thickness of tape, and if the recording tab is out or in.

Camcorder care

- When the camcorder is not to be used for a long time, disconnect the power source and remove the cassette. Periodically turn on the power, operate the camera and player sections and play back a tape for about 3 minutes.
- Clean the lens with a soft brush to remove dust. If there are fingerprints on the lens, remove them with a soft cloth.
- If there are fingerprints on the LCD screen, remove them using an LCD cleaning kit (not supplied).
- Clean the camcorder body with a soft dry cloth, or a soft cloth lightly moistened with a mild detergent solution. Do not use any type of solvent which may damage the finish.
- Do not let sand get into the camcorder. When you use the camcorder on a sandy beach or in a dusty place, protect it from the sand or dust. Sand or dust may cause the unit to malfunction, and sometimes this malfunction cannot be repaired.

AC power adaptor

Charging

- Attach the battery pack firmly.
- Place the battery pack on a flat surface without vibration during charging.

Others

- Unplug the unit from the wall outlet when not in use for a long time. To disconnect the power cord, pull it out by the plug. Never pull the cord itself.
- Do not operate the unit with a damaged cord or if the unit has been dropped or damaged.
- Do not bend the AC power cord (mains lead) forcibly, or put a heavy object on it. This will damage the cord and may cause a fire or an electrical shock.
- Be sure that nothing metallic comes into contact with the metal parts of the connecting plate. If this happens, a short may occur and the unit may be damaged.
- Always keep the metal contacts clean.
- Do not disassemble the unit.
- Do not apply mechanical shock or drop the unit.
- While the unit is in use, particularly during charging, keep it away from AM receivers and video equipment because it will disturb AM reception and video operation.
- The unit becomes warm while in use. This is normal.
- Do not place the unit in locations that are:
 - Extremely hot or cold
 - Dusty or dirty
 - Very humid
 - Vibrating

Notes on the dry batteries

To avoid possible damage from battery leakage or corrosion, observe the following.

- Be sure to insert the batteries in the correct direction.
- Dry batteries are not rechargeable.
- Do not use a combination of new and old batteries.
- Do not use different types of batteries.
- The batteries slowly discharge while not in use.
- Do not use a battery that is leaking.

If battery leakage occurred

- Wipe off the liquid in the battery compartment carefully before replacing the batteries.
- If you touch the liquid, wash it off with water.

If any difficulty should arise, unplug the unit and contact your nearest Sony dealer.

Using your camcorder abroad

Each country or area has its own electricity and TV color systems. Before using your camcorder abroad, check the following points:

Power sources

You can use your camcorder in any country or area with the supplied AC power adaptor within 110 V to 240 V AC, 50/60 Hz.

Use a commercially available AC plug adaptor [a], if necessary, depending on the design of the wall outlet [b].

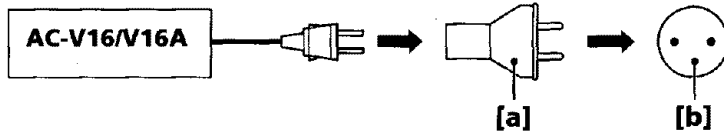

Additional information

Difference in color systems

This camcorder is an NTSC system-based camcorder. If you want to view the playback picture on a TV, it must be an NTSC-system based TV.

If you want to view the playback picture on a TV, it must be an NTSC system based TV or PAL M system based TV with an NTSC/PAL M transcoder.

Check the following list.

NTSC system

Bahama Islands, Bolivia, Canada, Central America, Chile, Colombia, Ecuador, Jamaica, Japan, Korea, Mexico, Peru, Surinam, Taiwan, the Philippines, the U.S.A., Venezuela, etc.

PAL system

Australia, Austria, Belgium, China, Denmark, Finland, Germany, Great Britain, Holland, Hong Kong, Italy, Kuwait, Malaysia, New Zealand, Norway, Portugal, Singapore, Spain, Sweden, Switzerland, Thailand, etc.

PAL M system

Brazil

PAL N system

Argentina, Paraguay, Uruguay

SECAM system

Bulgaria, Czech Republic, France, Guyana, Hungary, Iran, Iraq, Monaco, Poland, Russia, Slovak Republic, Ukraine, etc.

Trouble check

If you run into any problem using the camcorder, use the following table to troubleshoot the problem. Should the difficulty persist, disconnect the power source and contact your Sony dealer or local authorized Sony service facility.

Camcorder

Power

Symptom	Cause and/or Corrective Actions
The power is not on.	<ul style="list-style-type: none"> • The battery pack is not installed. → Attach the battery pack firmly by pushing the lower part of the battery pack until it clicks twice. (p. 9) • The battery is dead. → Use a charged battery pack. (p. 7) • The AC power adaptor is not connected to a wall outlet. → Connect the AC power adaptor to a wall outlet. (p. 24)
The power goes off.	<ul style="list-style-type: none"> • While being operated in CAMERA mode, the camcorder has been in the Standby mode for more than 5 minutes. → Turn STANDBY down once and turn it up again. (p. 12) • The battery is dead. → Use a charged battery pack. (p. 7)
The battery pack is quickly discharged.	<ul style="list-style-type: none"> • The ambient temperature is too low. (p. 53) • The battery pack has not been charged fully. → Charge the battery pack again. (p. 7) • The battery pack is completely dead, and cannot be recharged. → Use another battery pack. (p. 54)

Operation

Symptom	Cause and/or Corrective Actions
START/STOP does not operate.	<ul style="list-style-type: none"> • The tape is stuck to the drum. → Eject the cassette. (p. 10) • The tape has run out. → Rewind the tape or use a new one. (p. 21) • The POWER switch is set to PLAYER. → Set it to CAMERA. (p. 11) • The tab on the cassette is out (red). → Use a new cassette or slide the tab. (p. 10)
The cassette cannot be removed from the holder.	<ul style="list-style-type: none"> • The battery is dead. → Use a charged battery pack or the AC power adaptor. (p. 7, 24)
No function except for cassette ejection works.	<ul style="list-style-type: none"> • Moisture condensation has occurred. → Remove the cassette and leave the camcorder for at least 1 hour. (p. 56)
The tape does not move when a tape transport button is pressed.	<ul style="list-style-type: none"> • The POWER switch is set to CAMERA or OFF. → Set it to PLAYER. (p. 21) • The tape has run out. → Rewind the tape or use a new one. (p. 21)
The date or time indicator is flashing.	<ul style="list-style-type: none"> • The lithium battery is weak or dead. → Replace the lithium battery with a new one. (p. 49) • You pressed DATE and TIME together for more than 2 seconds. The camcorder is not malfunctioning. → You may start recording. Flashing will stop soon.

Trouble check

Symptom	Cause and/or Corrective Actions
The End Search function does not activate.	<ul style="list-style-type: none"> The cassette was ejected after you recorded on it. → The End Search function will not activate until you make a new recording after reinserting the cassette.
The date or time indicator disappears.	<ul style="list-style-type: none"> Reset the date and time. (p. 50)
The SteadyShot function does not activate.	<ul style="list-style-type: none"> STEADY SHOT is set to OFF. → Set STEADY SHOT to ON. (p. 39) The SteadyShot function does not work when the wide mode is set to 16:9FULL. (p. 39)
The autofocus function does not work.	<ul style="list-style-type: none"> FOCUS is set to MANUAL. → Set it to AUTO. (p. 36) Shooting conditions are not suitable for autofocus. → Set FOCUS to MANUAL to focus manually. (p. 36)
Recording stops in a few seconds.	<ul style="list-style-type: none"> START/STOP MODE switch is set to $\frac{1}{2}$ or 5SEC. → Set it to $\frac{2}{3}$. (p. 14)
The title display position shifts.	<ul style="list-style-type: none"> There are unwanted blanks before or after the title. → Delete them then select $\frac{1}{2}$.
The fader function does not work.	<ul style="list-style-type: none"> The START/STOP MODE switch is set to 5SEC or $\frac{1}{2}$. → Set it to $\frac{2}{3}$. (p. 14)
No sound or only a low sound is heard when playing back a tape (CCD-TRV52/TRV512 only).	<ul style="list-style-type: none"> The stereo tape is played back with HiFi SOUND set to 1 or 2 in the menu system. → Set to STEREO in the menu system (p. 27)

Additional information

Picture

Symptom	Cause and/or Corrective Actions
The image on the viewfinder screen is not clear.	<ul style="list-style-type: none"> The viewfinder lens is not adjusted. → Adjust the viewfinder lens. (p. 12)
A vertical band appears when a subject such as lights or a candle flame is shot against a dark background.	<ul style="list-style-type: none"> The contrast between the subject and background is too high. The camcorder is not malfunctioning. → Change locations.
The picture is "noisy".	<ul style="list-style-type: none"> The video heads may be dirty. → Clean the heads using the Sony V8-25CLH cleaning cassette. (p. 57)
The picture does not appear in the viewfinder.	<ul style="list-style-type: none"> The LCD panel is open. → Close the LCD panel. (p. 15)
The picture does not appear on the LCD screen.	<ul style="list-style-type: none"> Incorporated fluorescent tube is worn out. → Please contact your nearest Sony dealer.
A vertical band appears when shooting a very bright subject.	<ul style="list-style-type: none"> The camcorder is not malfunctioning.
An unknown picture is displayed in the viewfinder or on the LCD screen.	<ul style="list-style-type: none"> If 10 minutes elapsed after you set the POWER switch to CAMERA without inserting a cassette, the camcorder automatically starts the demonstration. → Insert the cassette, and the demonstration stops. You can make the demonstration not appear in the menu system. (p. 27)

Continued to the next page

Trouble check

Others

Symptom	Cause and/or Corrective Actions
The supplied Remote Commander does not work .	<ul style="list-style-type: none">• COMMANDER is set to OFF. → Set it to ON in the menu system. (p. 27)• Something is blocking the infrared rays. → Remove the obstacle.• The battery is not inserted with the correct polarity. → Insert the battery with the correct polarity. (p. 72)• The batteries are dead. → Insert new ones. (p. 72)
There is dust in the viewfinder. (CCD-TRV32/TRV52/TRV312/ TRV512 only)	<ul style="list-style-type: none">• Detach the eyecup and clean the viewfinder lens. (p. 58)

Trouble check

AC power adaptor

Symptom	Cause and/or Corrective Actions
The POWER lamp does not light.	• Set the selector to VTR (DC OUT) and disconnect the power cord. After about one minute, try again. (p. 9)
The CHARGE lamp flashes.	• See the following chart.

When the CHARGE lamp flashes

Check through the following chart.

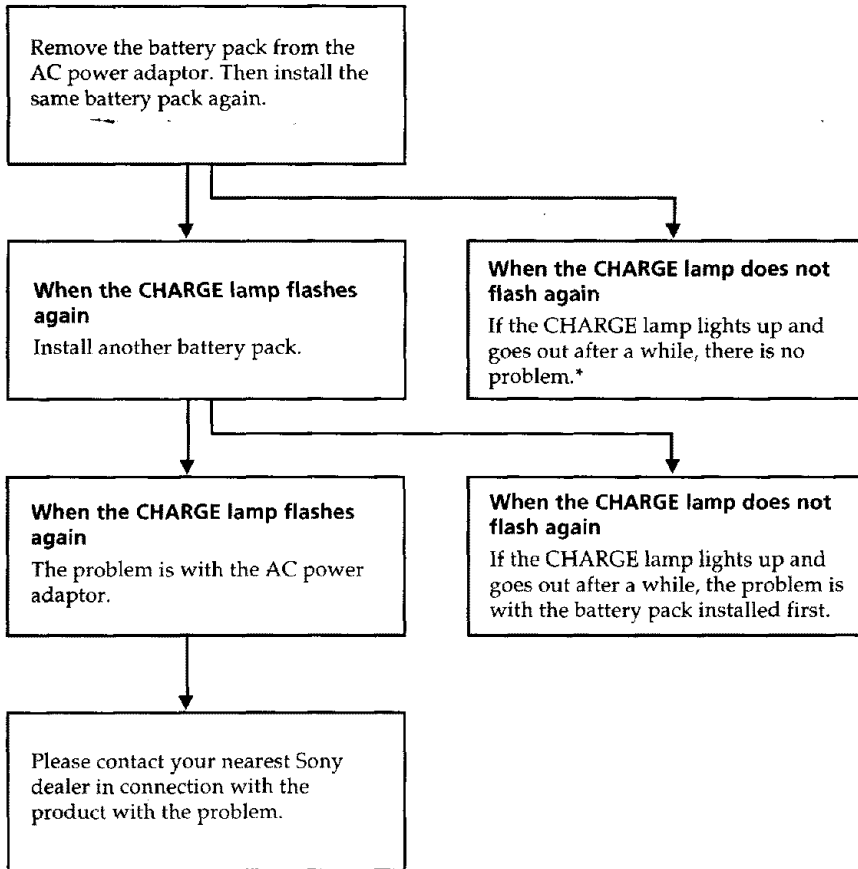

Additional information

* If you use a battery pack which you have just bought or which has been left unused for a long time, the CHARGE lamp may flash at the first charging. This does not indicate a problem. Repeat again to charge with the same battery pack.

Specifications

Video camera recorder

System

Video recording system

Four rotary heads (SP/LP independent heads), Helical scanning, FM system

Audio recording system

Rotary heads, FM system

Video signal

NTSC color, EIA standards

Usable cassette

8 mm video format cassette (standard 8 mm)

Recording/Playback time

SP mode: 2 hours (P6-120)

LP mode: 4 hours (P6-120)

Fastforward/rewind time

Approx. 5 min. (P6-120)

Image device

CCD (Charge Coupled Device)

Viewfinder

Electronic viewfinder

CCD-TRV53: color

Other models: Black and white

Lens

15× (optical), 30× (digital)

Combined power zoom lens, F1.4 - 2.4

Filter diameter 1 1/2 inches (37 mm)

Focal distance

$f = \frac{3}{16} - 2 \frac{1}{2}$ inches (4.1 - 61.5 mm)

When converted to a 35 mm still camera

1 7/8 - 27 7/8 inches (47 - 705 mm)

Color temperature

Auto

Minimum illumination

2 lx at F 1.4

Illumination range

2 to 100,000 lx

Recommended illumination

More than 100 lx

LCD screen

Picture

CCD-TRV52/TRV512: 3.5 inches measured diagonally 2 7/8 x 2 inches (72.4 x 50.38 mm)

CCD-TRV32/TRV53/TRV312: 3 inches measured diagonally

2 3/8 x 1 3/4 inches (59.5 x 43.2 mm)

On-screen display

TN LCD/TFT active matrix method

Total dot number

CCD-TRV52/TRV512:

105,380 (479 x 220)

CCD-TRV32/TRV53/

TRV312: 89,622 (383 x 234)

Input and Output

connectors

Video output

Phono jack, 1 Vp-p, 75 ohm, unbalanced

Audio output

327 mV, (at load impedance 47 kilohm), impedance less than 2.2 kilohm

CCD-TRV32/TRV53/

TRV312: Monaural, Phono jack

CCD-TRV52/TRV512: Phono jacks (2: stereo L and R)

RFU DC OUT

Special minijack, DC 5 V

Earphone jack

(CCD-TRV32/TRV53/TRV312 only) Mini-jack

Headphone jack

(CCD-TRV52/TRV512 only) Stereo minijack

LANC control jack

Stereo mini-minijack (ø 2.5 mm)

MIC jack

Minijack, 0.388 mV, low impedance with 2.5 to 3 V DC output, impedance 6.8 kilohm (ø 3.5 mm)

Speaker

Dynamic-speaker

General

Power requirements

7.5 V (AC power adaptor)

Average power consumption

During camera recording using the LCD

CCD-TRV32/TRV53/

TRV312: 4.7 W

CCD-TRV52/TRV512: 5.0 W

During camera recording using the viewfinder

CCD-TRV32/TRV53/

TRV312: 3.5 W

CCD-TRV52/TRV512: 3.6 W

Operating temperature

32°F to 104°F (0°C to 40°C)

Storage temperature

-4°F to +140°F (-20°C to +60°C)

Dimensions (w/h/d)

Approx. 4 5/8 x 4 3/8 x 8 1/8 inches (115 x 110 x 205 mm)

Mass

CCD-TRV32/TRV53/

TRV312:

Approx. 2 lb 1 oz (950 g)

CCD-TRV52/TRV512:

Approx. 2 lb 1 oz (960 g)

Excluding the battery pack, lithium battery, cassette and shoulder strap

CCD-TRV32/TRV52/

TRV53/TRV312/TRV512:

2 lb 7 oz (1.2 kg)

Including the battery pack NP-33, lithium battery

CR2025, cassette P6-120 and shoulder strap

Microphone

Electret condenser

microphone

CCD-TRV32/TRV53/

TRV312: Monaural type

CCD-TRV52/TRV512: Stereo type

Supplied accessories

See page 6.

Specifications

AC power adaptor

Power requirements

110 – 240 V AC, 50/60Hz

Power consumption

AC-V16: 20 W

AC-V16A: 22 W

Output voltage

DC OUT in operation mode

7.5 V, 1.8 A

Battery charge terminal

10 V, 1.1 A in charge mode

Application

Sony battery packs NP-33 (supplied), NP-60D, NP-C65, NP-68, NP-80/80D, NP-98/98D

Operating temperature

32 °F to 104 °F (0 °C to 40 °C)

Storage temperature

-4 °F to +140 °F (-20 °C to +60 °C)

Dimensions

Approx. 6 ⁵/₈ x 1 ¹¹/₁₆ x 3 inches (166 x 43 x 75 mm)

(w/h/d) including

projecting parts and controls

Mass

AC-V16: Approx. 15 oz (420 g)

AC-V16A: Approx. 16 oz (450 g)

Design and specifications are subject to change without notice.

Identifying the parts

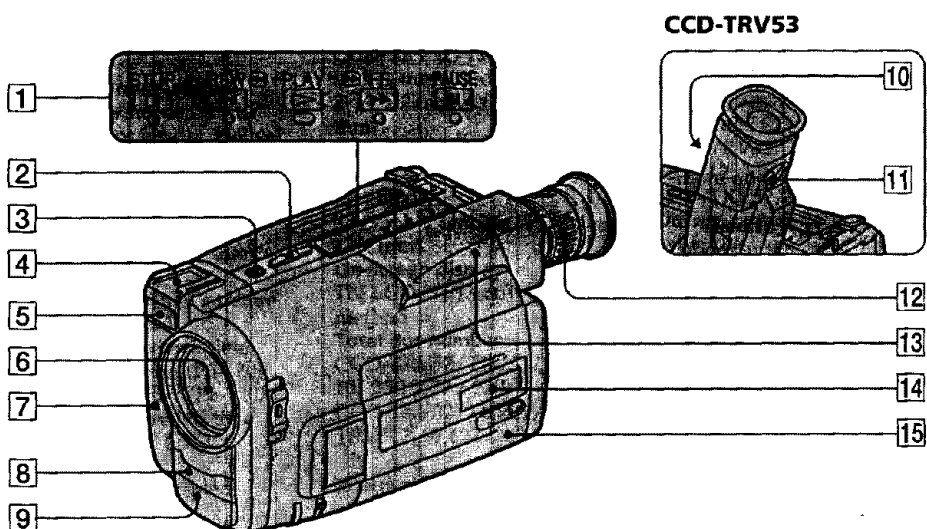

- 1 Tape transport buttons (p. 21, 22)
 - STOP
 - ◀ REW (rewind)
 - ▷ PLAY (playback)
 - ▶▶ FF (fast forward)
 - || PAUSE
 These buttons will function in PLAYER mode.
- 2 EDITSEARCH button (p. 19)
- 3 LASER LINK button (p. 46)
CCD-TRV52/TRV53/TRV512 only
- 4 Accessory shoe
- 5 Transmitter
CCD-TRV52/TRV53/TRV512 only
- 6 Lens cover
- 7 Recording lamp
- 8 Remote sensor (p. 73)
Aim the Remote Commander here for remote control.
- 9 Built-in microphone
- 10 Lighting aperture
CCD-TRV53 only
- 11 Viewfinder adjustment lever (p. 12)
CCD-TRV53 only
- 12 Viewfinder adjustment ring (p. 12)
CCD-TRV32/TRV52/TRV312/TRV512 only
- 13 Viewfinder (p. 58, 74)
- 14 LCD panel (p. 15, 16, 21)
- 15 Display window (p. 74)

Identifying the parts

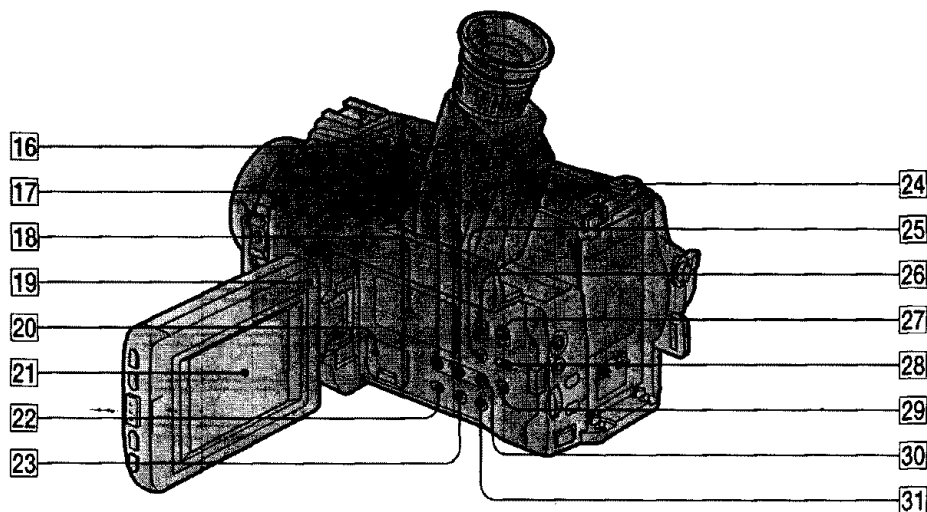



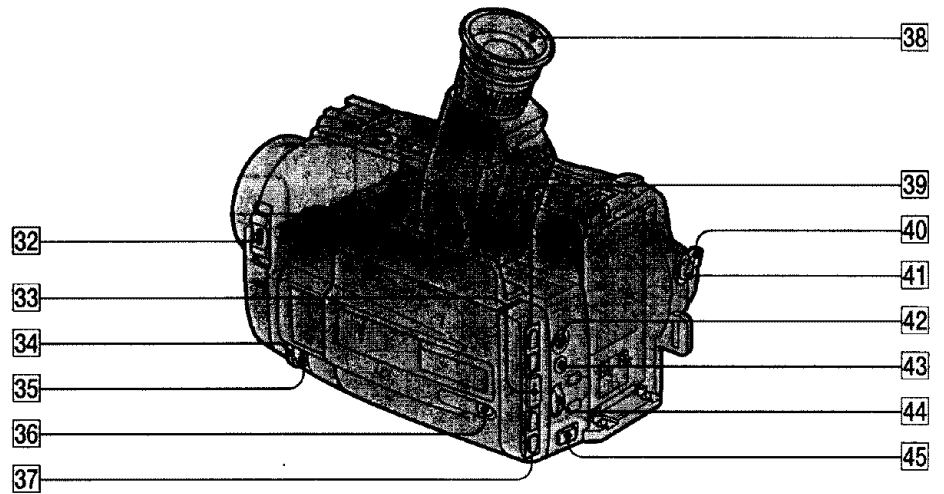

Additional information

- | | |
|---|---|
| 16 TIME button (p. 30) | 25 DISPLAY button (p. 21) |
| 17 DATE button (p. 30) | 26 STEADY SHOT button (p. 39) |
| 18 Speaker | 27 START/STOP MODE switch (p.11, 14) |
| 19 Recording lamp | 28 PICTURE EFFECT button (p. 33) |
| 20 Lithium battery compartment (p. 49) | 29 MENU button (p. 27) |
| 21 LCD screen (p. 15, 16, 21, 74) | 30 COUNTER RESET button (p. 12) |
| 22 16:9 WIDE button (p. 35) | 31 END SEARCH button (p. 23) |
| 23 TITLE button (p. 41) | |
| 24 Power zoom lever (p. 13) | |

Identifying the parts



- 32 POWER switch (p. 11, 21)
- 33 PUSH OPEN button (p. 15, 16, 21)
- 34 Focus dial (p. 36)
- 35 FOCUS switch (p. 36)
- 36 PROGRAM AE button (p. 37)
- 37 VOLUME button (p. 21)
- 38 Eyecup (p. 58)
- 39 BRIGHT button (p. 15)
- 40 STANDBY switch (p. 11)
- 41 START/STOP button (p. 11)

- 42 LANC  control jack
 stands for Local Application Control Bus system. The  control jack is used for controlling the tape transport of video equipment and peripherals connected to it. This jack has the same function as the connectors indicated as CONTROL L or REMOTE.
- 43 CCD-TRV32/TRV312/TRV53:  (earphone) jack (p. 22)
CCD-TRV52/TRV512:  (headphones) jack (p. 22)
- 44 Menu control dial (p. 27)
- 45 BATT (battery release) knob (p. 9)

Identifying the parts

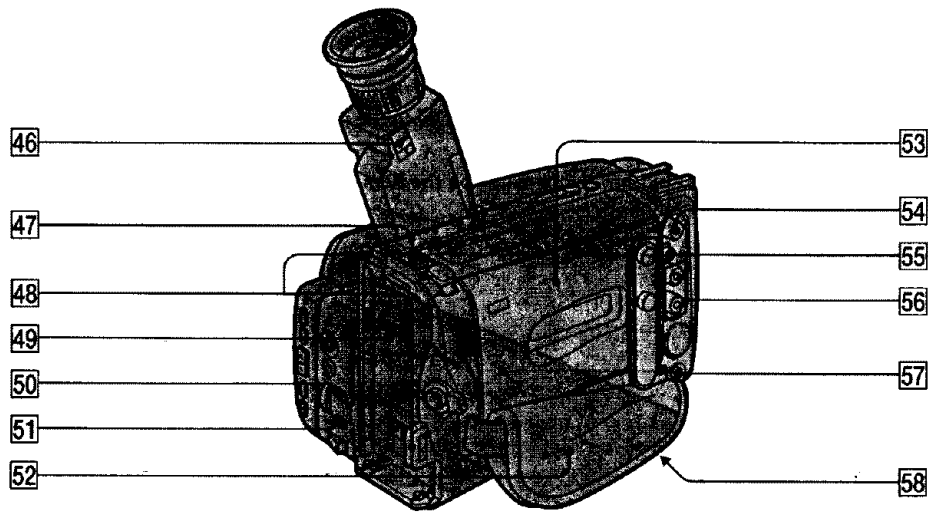

Additional information

46 Eyecup release knob (p. 58)
 CCD-TRV32/TRV52/TRV312/TRV512
 only

47 EJECT knob (p. 10)

48 Hooks for shoulder strap

49 Battery mounting surface (p. 9)

50 FADER button (p. 31)

51 BACK LIGHT button (p. 38)

52 Cassette compartment (p. 10)

53 VIDEO OUT jack (p. 45)

54 RFU DC OUT (RFU adaptor DC out)
 jack

55 AUDIO OUT jack (p. 45)

56 MIC (microphone) jack
 Connect an external microphone (not
 supplied). This jack also accepts a "plug-
 in-power" microphone.

57 Grip strap (p. 17)

58 Tripod receptacle (p. 17)

Make sure that the length of the tripod
 screw is less than 9/32 inch (6.5 mm).
 Otherwise, you cannot attach the tripod
 securely and the screw may damage the
 camcorder.

Attaching the shoulder strap

Attach the supplied shoulder strap to the hooks for the shoulder strap **48**.

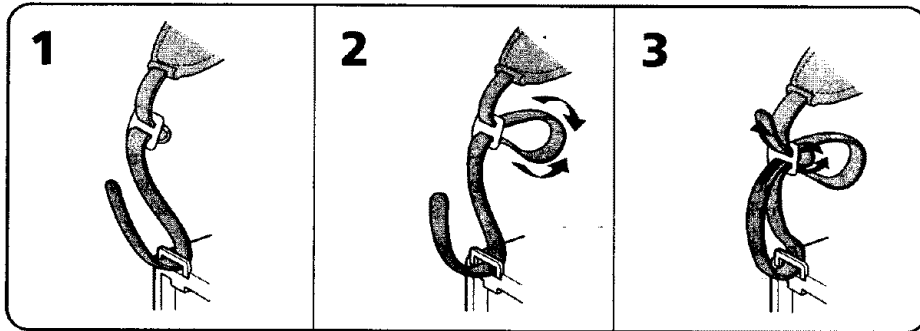

Identifying the parts

Remote Commander

Using the Remote Commander

Make sure that COMMANDER is set to ON in the menu system.

The buttons that have the same name on the Remote Commander as on the camcorder function identically.

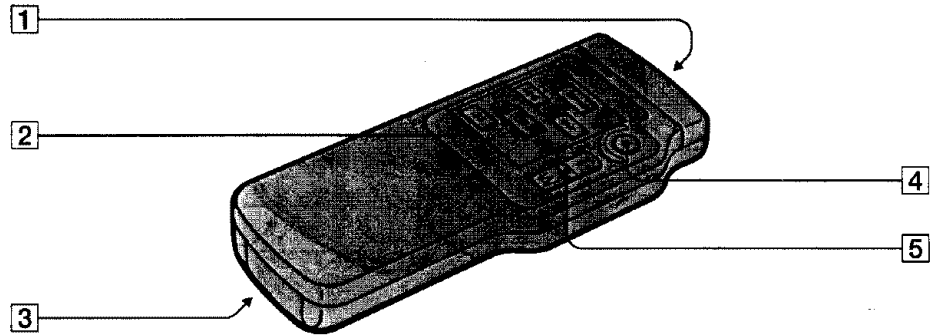

1 Transmitter

Point toward the remote sensor to control the camcorder after turning on the camcorder.

2 Tape transport buttons (p. 21, 22)

3 Size AA (R6) battery compartment

4 START/STOP button (p. 11)

5 Power zoom button (p. 13)

The zooming speed is unchangeable on the Remote Commander.

To prepare the remote commander

Insert two size AA (R6) batteries by matching the + and - on the batteries to the diagram inside the battery compartment.

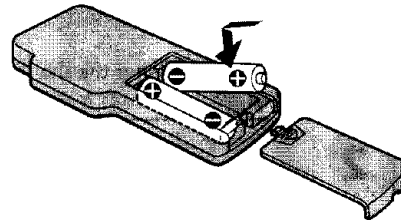

Note on battery life

The batteries for the Remote Commander last about 6 months under normal operation. When the batteries become weak or dead, the Remote Commander does not work.

To avoid damage from possible battery leakage

Remove the batteries when you will not use the Remote Commander for a long time.

Remote control direction

Aim the Remote Commander to the remote sensor within the range as shown below.

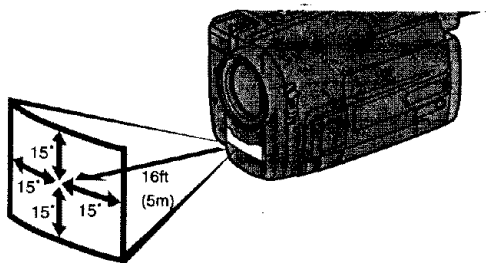

Notes on the Remote Commander

- Keep the remote sensor away from strong light sources such as direct sunlight or illumination. Otherwise, the remote control may not be effective.
- Be sure that there is no obstacle between the remote sensor on the camcorder and the Remote Commander.
- This camcorder works at commander mode VTR 2. The commander modes (1, 2, and 3) are used to distinguish this camcorder from other Sony VCRs to avoid remote control misoperation. If you use another Sony VCR at commander mode VTR 2, we recommend you change the commander mode or cover the remote sensor of the VCR with black paper.

To watch the demonstration

You can start the demonstration by setting in the menu system.

You can also start the demonstration by the following operation.

To enter demo mode

- (1) Eject the cassette and set the POWER switch to PLAYER.
- (2) Turn STANDBY up.
- (3) While holding down \triangleright set the POWER switch to CAMERA.

To exit demo mode

- (1) Set the POWER switch to PLAYER.
- (2) Turn STANDBY up.
- (3) While holding down \square set the POWER switch to CAMERA.

Operation Indicators

In the viewfinder and on the LCD screen

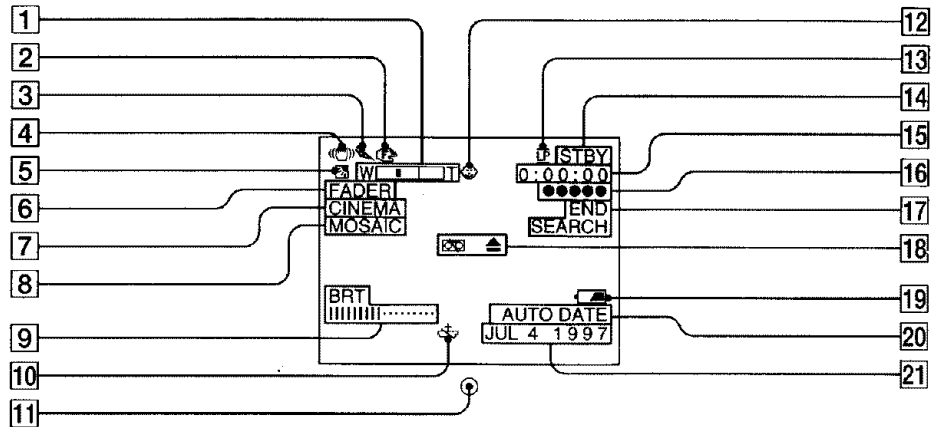

- | | |
|--|--|
| 1 Power zoom indicator (p. 13) | 12 Mirror mode indicator (p. 16) |
| 2 Manual focus indicator (p. 36) | 13 LP recording mode indicator (p. 11) |
| 3 PROGRAM AE indicator (p. 37) | 14 Tape transport mode indicator (p. 11) |
| 4 SteadyShot indicator (p. 39) | 15 Tape counter (p. 12) |
| 5 Back light indicator (p. 38) | 16 5SEC recording indicator (p. 14) |
| 6 FADER indicator (p. 31) | 17 END SEARCH indicator (p. 23) |
| 7 Wide mode indicator (p. 34) | 18 Warning indicators (p. 75) |
| 8 Picture Effect indicator (p. 32) | 19 Remaining battery indicator (p. 53) |
| 9 BRT (brightness) indicator (p. 15) | |
| VOL (volume) indicator (p. 21) | |
| 10 Lithium battery indicator (p. 48) | 20 AUTO DATE indicator (p. 11) |
| 11 Recording lamp/battery lamp (p. 11) | 21 Date or Time (p. 30) |
| (in the viewfinder) | |



In the display window

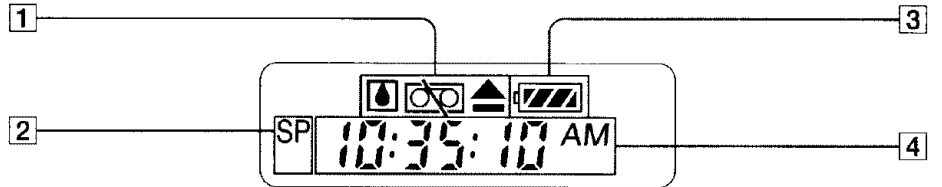

- | | |
|--|---------------------------------------|
| 1 Warning indicators (p. 75) | 3 Remaining battery indicator (p. 53) |
| 2 Recording mode indicator (SP/LP) (p. 11) | |
| | 4 Date or time (p. 30) |
| | Tape counter (p. 12) |



Warning indicators

The warning indicators and the recording lamp flash to inform you of the following situations. The illustrations below are the warning indicators of the viewfinder and the LCD screen. The same indicators flash also in the display window.

D: You can hear the beep sound when BEEP is set to ON in the menu system.

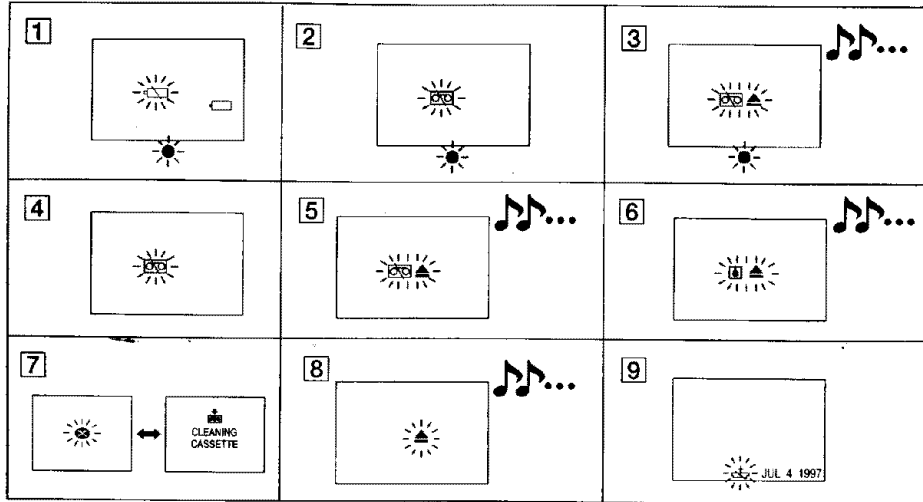

Additional information

- | | |
|---|---|
| <p>1 The battery is weak or dead.
Slow flashing: The battery is weak.
Fast flashing: The battery is dead.</p> <p>2 The tape is near the end.</p> <p>3 The tape has run out.</p> <p>4 No tape has been inserted.</p> <p>5 The tab on the tape is out (red). (p. 10)</p> <p>6 Moisture condensation has occurred.
(p. 56)
▲ indicator appears only when the cassette is inserted.</p> | <p>7 The video heads may be contaminated.
(p. 57)</p> <p>8 Some other trouble has occurred.
Disconnect the power source and contact your Sony dealer or local authorized facility.</p> <p>9 The lithium battery is weak or is not installed. (p. 48)
This indicator flashes just only after powering on.</p> |
|---|---|

Index

A

Adjusting viewfinder 12
ANTI GROUND
SHOOTING 14
AUTO DATE 13

B

BACK LIGHT 38
BEEP 12, 28

C

Camera recording 11
Car battery 26
Charging battery 7
Cleaning video heads 57
COUNTER RESET 12

D

DATE/TIME 30
Demonstration 28
Digital zoom 13

E

Editing 47
EDITSEARCH 19
EJECT 10
END SEARCH 23

F, G, H

Fade-in/Fade-out 31
FADER 31
Fast-forward 21
5 sec. recording 14
High-speed shutter mode 37
House current 24

I, J, K, L

LANC 70
LASER LINK 46
Lithium battery 48

M, N, O, P

Manual focus 36
Menu 27
MIC (microphone) jack 71
PICTURE EFFECT 32
Playback 21
Playback pause 22
Power sources 24
Power zoom 13
PROGRAM AE 37

Q, R

REC MODE 28
Rec. Review 19
Remote Commander 72
Remote control jack
(LANC) 70
Rewind 21

S

Shoulder strap 71
Sports mode 37
STANDBY 11, 12
Standby mode 12
STEADY SHOT 39
Supplied accessories 6

T, U, V

Tape counter 12
Title 40
Tripod mounting 17
Trouble check 62
Twilight mode 37

W, X, Y, Z

Wide mode 34
Zoom 13