

Owner's Manual

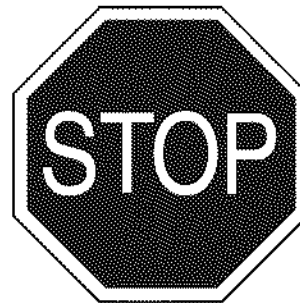

25 GALLON 70 PSI SPRAYER

Model No. 486.245332

DO NOT RETURN TO STORE
For Missing Parts or Assembly
Questions Call 1-866-576-8388

Most fasteners are readily available
through any hardware store

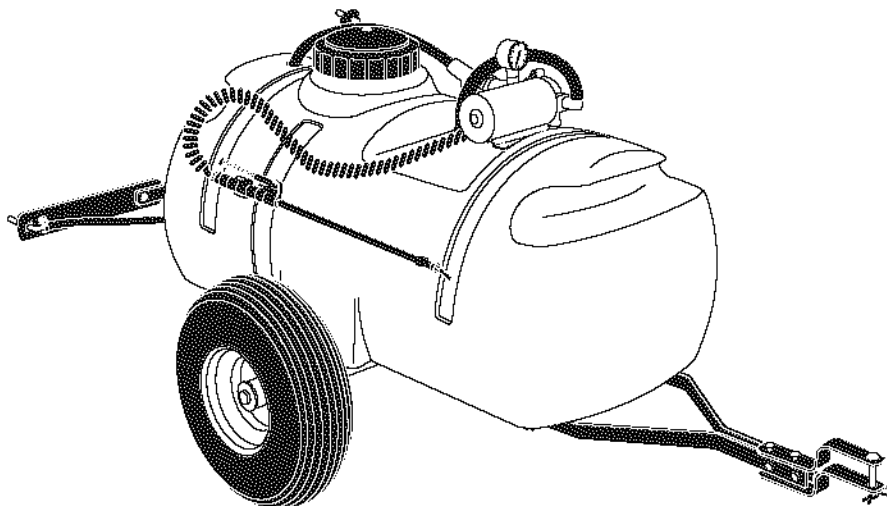

CAUTION:

Before using this product, read
this manual and follow all Safety
Rules and Operating Instructions.

- Safety
- Assembly
- Operation
- Maintenance
- Parts

Sears, Roebuck and Co., Hoffman Estates, IL 60179 U.S.A.
www.sears.com/craftsman

PRINTED IN U.S.A.

FORM NO. 40171 (1/06)

TABLE OF CONTENTS

SAFETY RULES.....	2	STORAGE	11
FULL SIZE HARDWARE CHART.....	3	TROUBLESHOOTING.....	12
CARTON CONTENTS.....	4	REPAIR PARTS ILLUSTRATION.....	14
ASSEMBLY.....	4	REPAIR PARTS LIST	15
OPERATION.....	8	PARTS ORDERING/SERVICE.....	Back Cover
MAINTENANCE	11		

WARRANTY

ONE YEAR FULL WARRANTY

When operated and maintained according to the instructions supplied with it, if this Sprayer fails due to a defect in material or workmanship within one year from the date of purchase, call 1-800-4-MY-HOME® to arrange for free repair (or replacement if repair proves impossible).

If this product is used for commercial or rental purposes, this warranty applies for only 90 days from the date of purchase.

This warranty gives you specific legal rights, and you may also have other rights which vary from state to state.

Sears, Roebuck and Co., D817WA, Hoffman Estates, IL 60179

<p>The model number and serial numbers will be found on a decal attached to the tank.</p> <p>You should record both the serial number and the date of purchase and keep in a safe place for future reference.</p>	<table style="width: 100%; border-collapse: collapse;"> <tr> <td style="width: 60%;">MODEL NUMBER:</td> <td style="width: 40%;">486.245332</td> </tr> <tr> <td>SERIAL NUMBER:</td> <td>_____</td> </tr> <tr> <td>DATE OF PURCHASE:</td> <td>_____</td> </tr> </table>	MODEL NUMBER:	486.245332	SERIAL NUMBER:	_____	DATE OF PURCHASE:	_____
MODEL NUMBER:	486.245332						
SERIAL NUMBER:	_____						
DATE OF PURCHASE:	_____						



SAFETY



Any power equipment can cause injury if operated improperly or if the user does not understand how to operate the equipment. Exercise caution at all times when using power equipment.

- Read this owners manual carefully before attempting to assemble or operate this sprayer.
- Read your vehicle owners manual for operating and safety rules before using this equipment.
- Never allow children to operate this sprayer, and do not allow adults to operate without proper instructions.
- Do not allow anyone to ride on or sit on this sprayer
- Do not allow passengers on the towing vehicle.
- Keep the area of operation clear of all persons, particularly small children. Also keep area clear of pets.
- Read the chemical label carefully for instructions and caution notes on handling and mixing of chemicals.
- Wear eye and hand protection and wear protective clothing when handling and applying lawn chemicals.
- Do not spray on windy days.
- Attachment of this sprayer may affect your tractor's braking and stability. Be aware of your tractor's capabilities. Refer to the safety rules in the vehicle owner's manual concerning safe operation on slopes
- Be aware of changing conditions on slopes. **STAY OFF OF STEEP SLOPES.**
- Operate at reduced speed on rough terrain, along ditches and on hillsides to prevent loss of control.
- Follow maintenance and lubrication instructions as outlined in this manual.



Look for this symbol to point out important safety precautions. It means — **Attention!! Become alert!! Your safety is involved.**

HARDWARE PACKAGE CONTENTS

SHOWN FULL SIZE

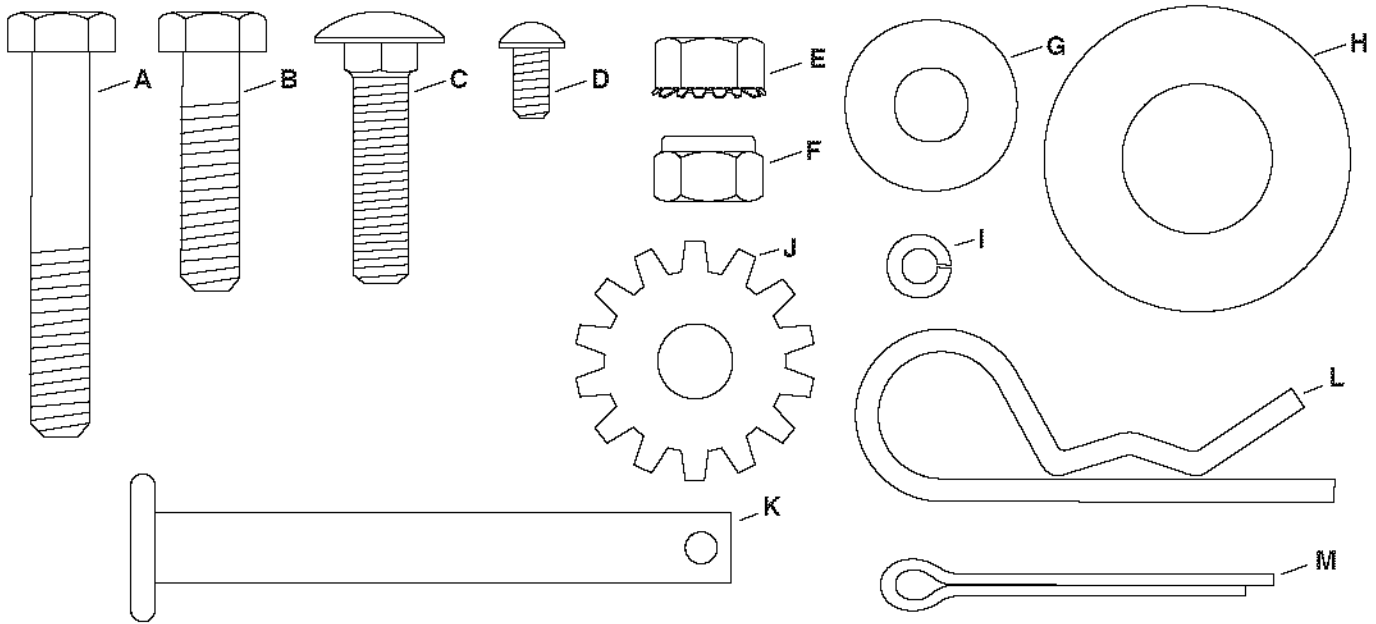

NOT SHOWN FULL SIZE

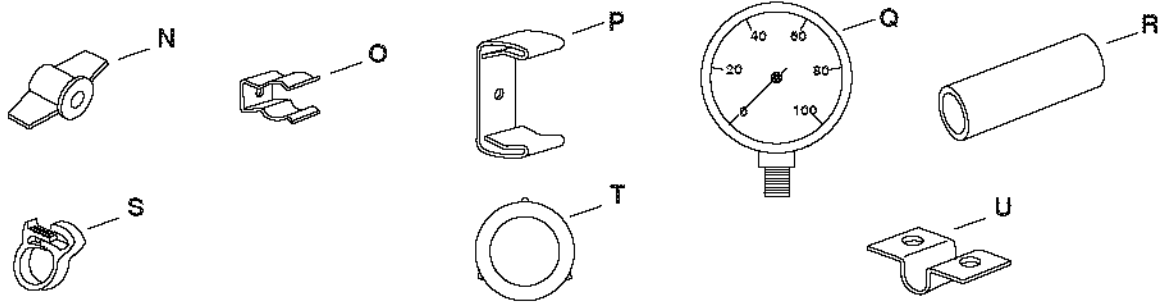

KEY	QTY.	DESCRIPTION	KEY	QTY.	DESCRIPTION
A	8	Hex Bolt, 5/16" x 2"	L	1	Hair Cotter Pin
B	2	Hex Bolt, 5/16" x 1-1/4"	M	2	Cotter Pin
C	2	Carriage Bolt, 5/16" x 1-1/4"	N	2	Knob
D	2	Screw, #10 x 3/8"	O	1	Spray Gun Clip, Small
E	4	Nut, 5/16" (SEMS)	P	1	Spray Gun Clip, Large
F	10	Nut, Nylock 5/16"	Q	1	Pressure Gauge
G	2	Flat Washer, 5/16"	R	2	Spacer
H	4	Flat Washer, 3/4"	S	1	Coiled Hose Clamp
I	2	Lock Washer, #10	T	2	Gasket, 3/4" Garden Hose
J	2	Washer, 5/16" Tooth Lock	U	2	Axle Clamp, 3/4"
K	1	Hitch Pin			

ASSEMBLY

CARTON CONTENTS

1. Lid
2. Tank
3. Return/Bypass Hose (may be assembled to tank)
4. Boom Assembly
5. Boom Mount Bracket
6. Spray Gun Assembly
7. Axle
8. Hitch Arms (2)
9. Hitch Brackets (2)
10. Wheels (2)

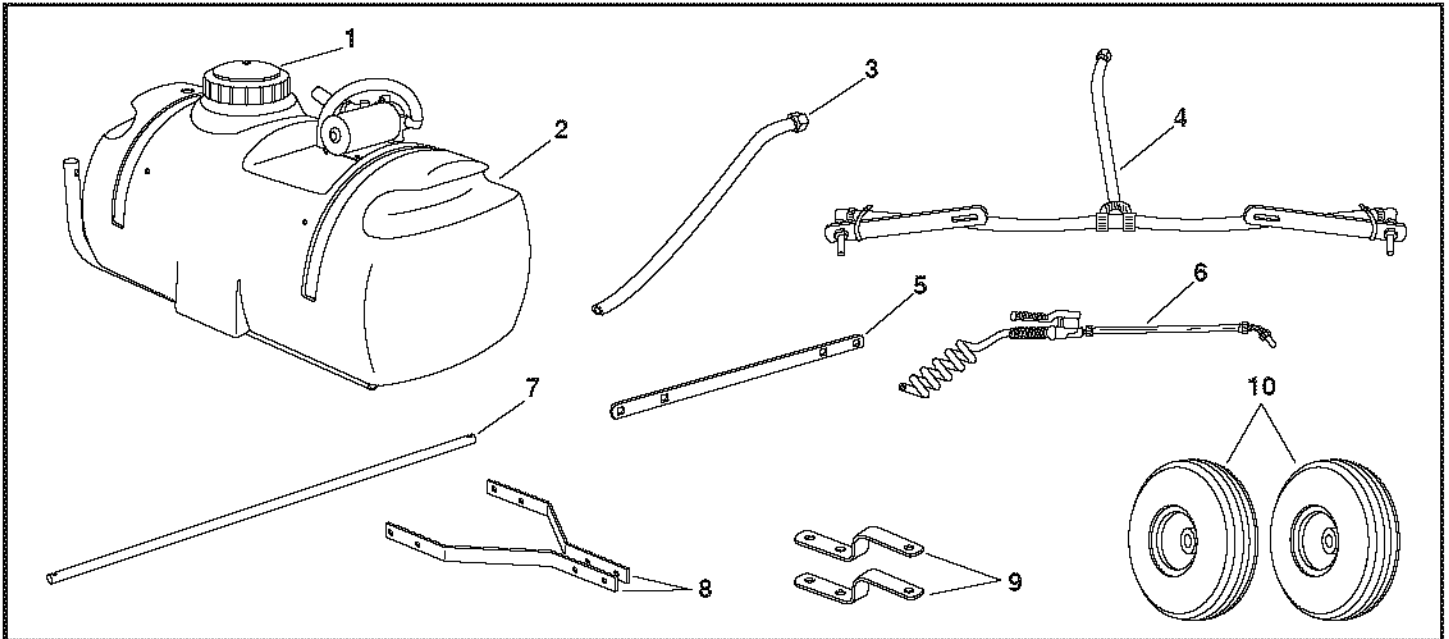

TOOLS REQUIRED FOR ASSEMBLY

- (2) 1/2" Wrenches
- (1) Screwdriver
- (1) Pliers
- (1) Hammer

STEP 1: (SEE FIGURE 1)

- Remove all items from carton and lay out as shown on pages 3 and 4.
- Assemble the axle clamps (U) and four 5/16" hex nuts (SEMS) (E) to the factory installed bolts in the frame tubes. **Do not tighten yet.**

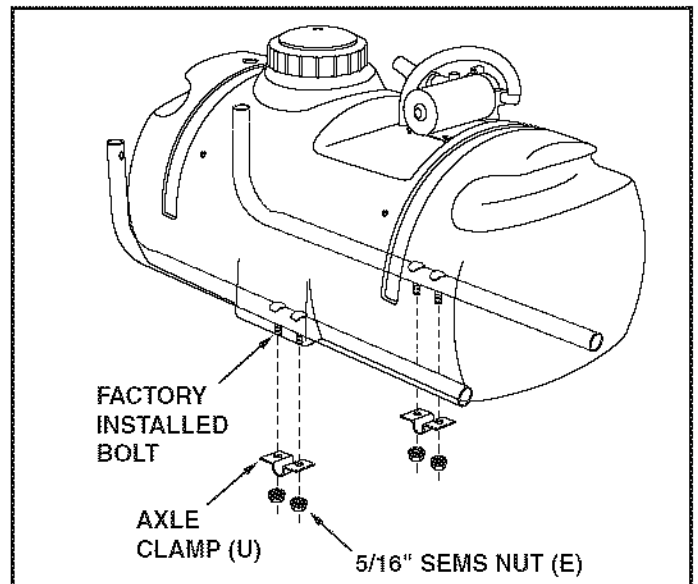

FIGURE 1

STEP 2: (SEE FIGURE 2 AND 1)

- Slide the axle through the two axle brackets.
- Assemble a spacer (R), a 3/4" washer (H), a wheel (valve stem facing out) and another 3/4" washer (H) onto the axle. Assemble a cotter pin (M) through the end of the axle. Repeat on other end.
- **Tighten** the four nuts which fasten the axle clamps to the frame tubes. Refer back to figure 1.

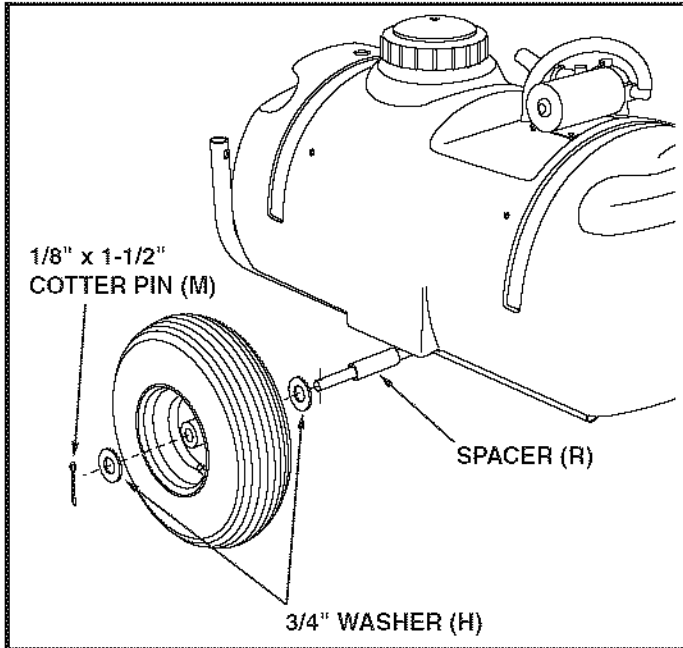

FIGURE 2

STEP 3: (SEE FIGURE 3)

- Assemble a hitch arm to the inside of a frame tube underneath the tank. Use two 5/16" x 2" hex bolts (A) and 5/16" nylock nuts (F). **Do not tighten yet.** Repeat for other side.

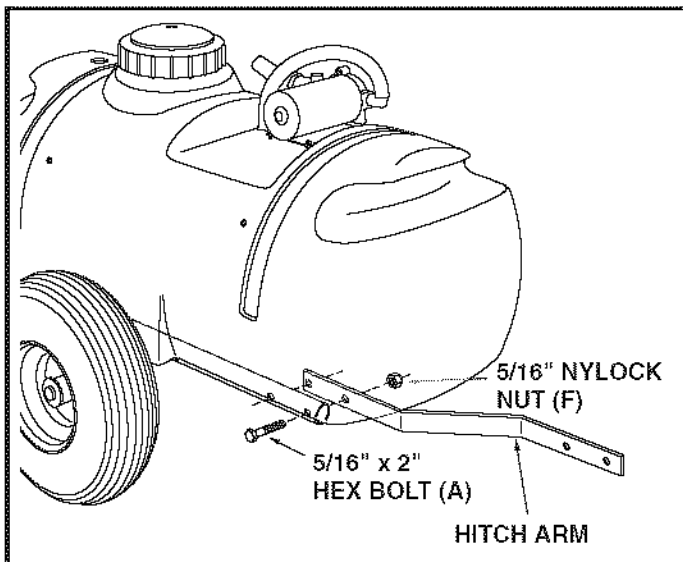

FIGURE 3

STEP 4: (SEE FIGURE 4)

- Fasten the ends of the hitch arms together using two 5/16" x 1-1/4" hex bolts (B) and 5/16" nylock nuts (F). **Do not tighten yet.**
- Assemble the hitch brackets to the hitch arms using two 5/16" x 2" hex bolts (A) and 5/16" nylock nuts (F). Position each bolt behind a cross bolt in the hitch arms. **Do not tighten yet.**
- **Tighten** all nuts assembled in steps 3 and 4 at this time.

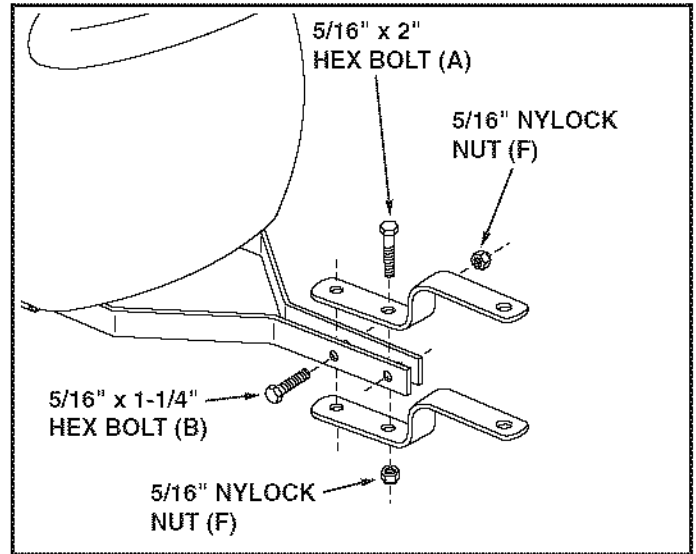

FIGURE 4

STEP 5: (SEE FIGURE 5)

- Assemble the boom mount bracket to the rear of the frame tubes using two 5/16" x 2" hex bolts (A) and 5/16" nylock nuts (F).

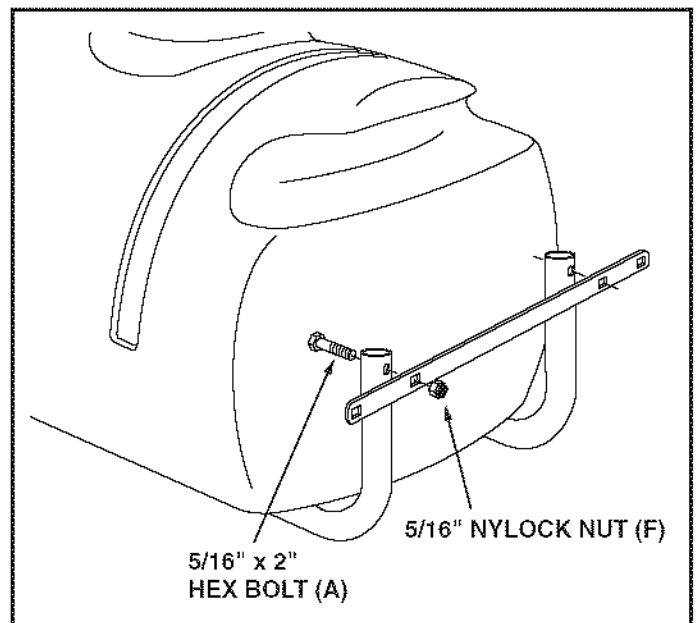

FIGURE 5

REAR VIEW

STEP 6: (SEE FIGURE 6)

- Assemble the boom bars to the boom mount bracket using two 5/16" x 1-1/4" carriage bolts (C), tooth lock washers (J) (between the bar and bracket), 5/16" flat washers (G) and knobs (N). The boom connecting hose should extend upward.

NOTE: Make sure the nozzles are adjusted so that the openings face straight down when the boom bar is in the horizontal operating position.

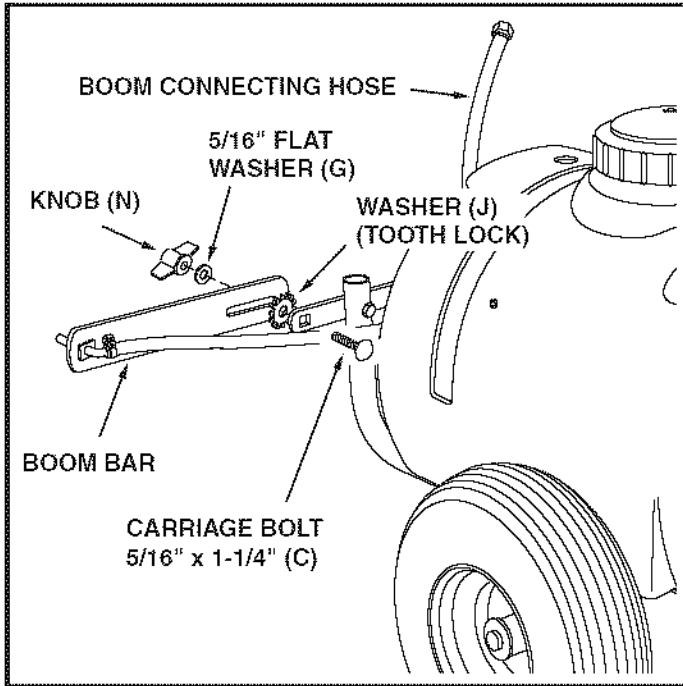

FIGURE 6

STEP 7: (SEE FIGURE 7)

- Assemble the large (P) and small (O) spray gun clips to the side of the tank using two #10 x 1/2" screws (D) and #10 lock washers (I).

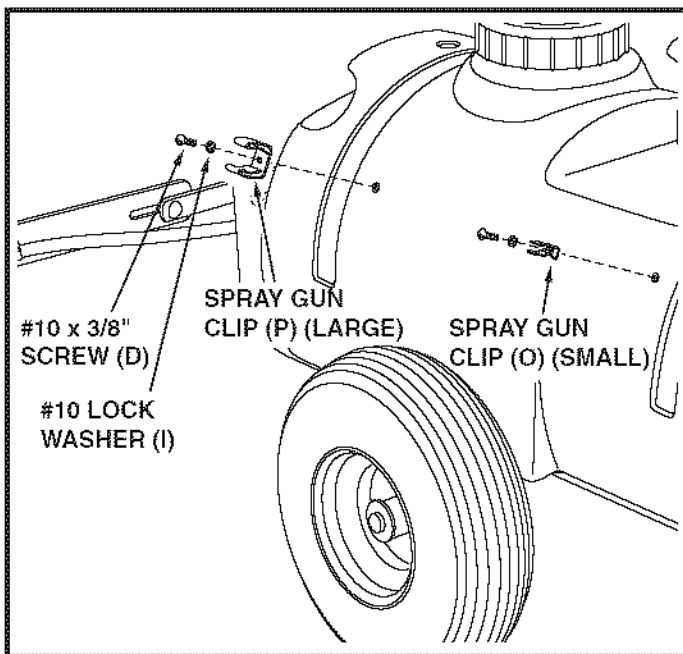

FIGURE 7

STEP 8: (SEE FIGURE 8)

- Insert a garden hose gasket (T) into the swivel nut on the bypass/return hose. Screw the nut onto the upper outlet of the "Y" valve fitting. Place the other end of the hose down through the hole at the rear of the tank.
- Insert a garden hose gasket (T) into the swivel nut on the boom connecting hose. Screw the nut onto the lower outlet of the "Y" valve fitting.
- Slide the coiled hose clamp (S) onto the spray gun hose. Push the hose onto the hose adapter on the side of the "T" fitting as shown in figure 8. Tighten the clamp around the hose and the adapter. Snap the spray gun into the clips on the side of the tank.
- Carefully screw the pressure gauge (Q) into the top of the "T" fitting.

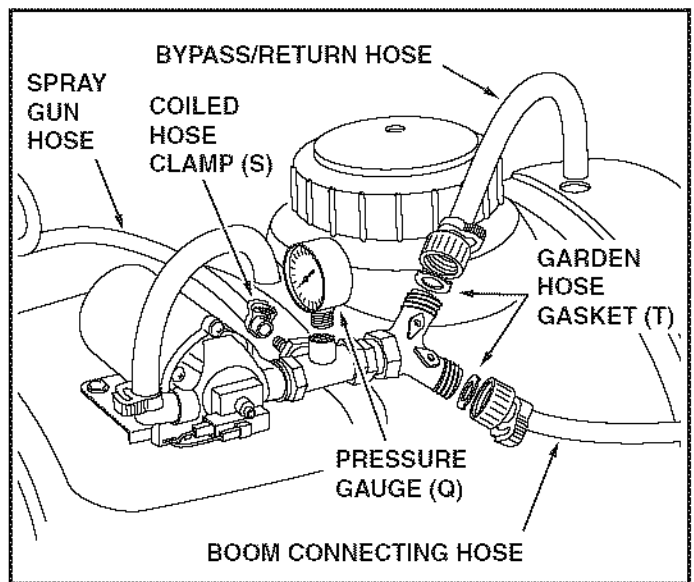

FIGURE 8

STEP 9: (SEE FIGURE 9 AND 10)

- Attach the sprayer to the tractor hitch and connect the wiring to the tractor battery. The red wire must be connected to the positive post on the battery or to the "HOT" connection on a tractor switch or ammeter. The brown wire may be grounded or connected to the negative battery post.

IMPORTANT: Connect to 12 volt batteries only!

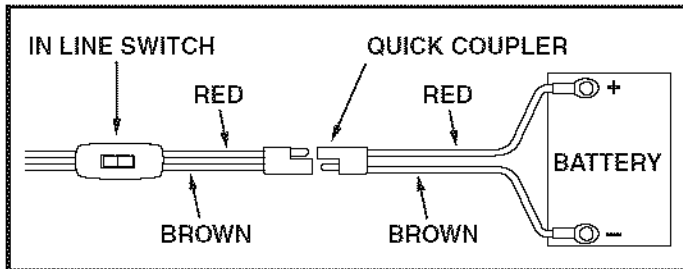



FIGURE 9

 **NEVER** allow negative pin on plug to come in contact with positive "Hot" post on battery. Fire or explosion may result.

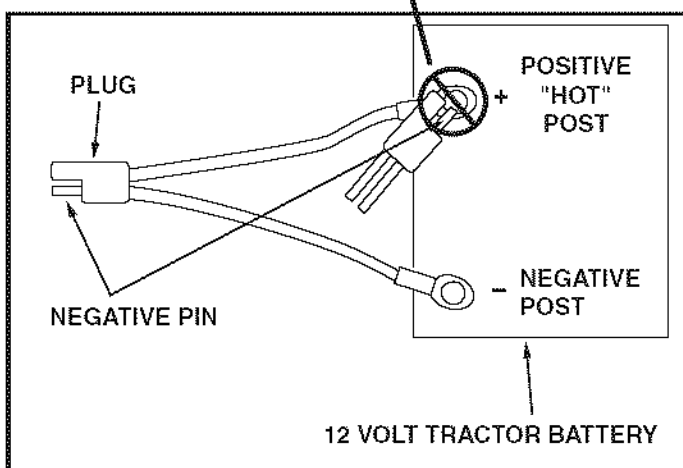

FIGURE 10

OPERATION

KNOW YOUR SPRAYER

Read this owner's manual and safety rules before operating your sprayer.

Compare the illustration below with your sprayer to familiarize yourself with the various controls and their locations.

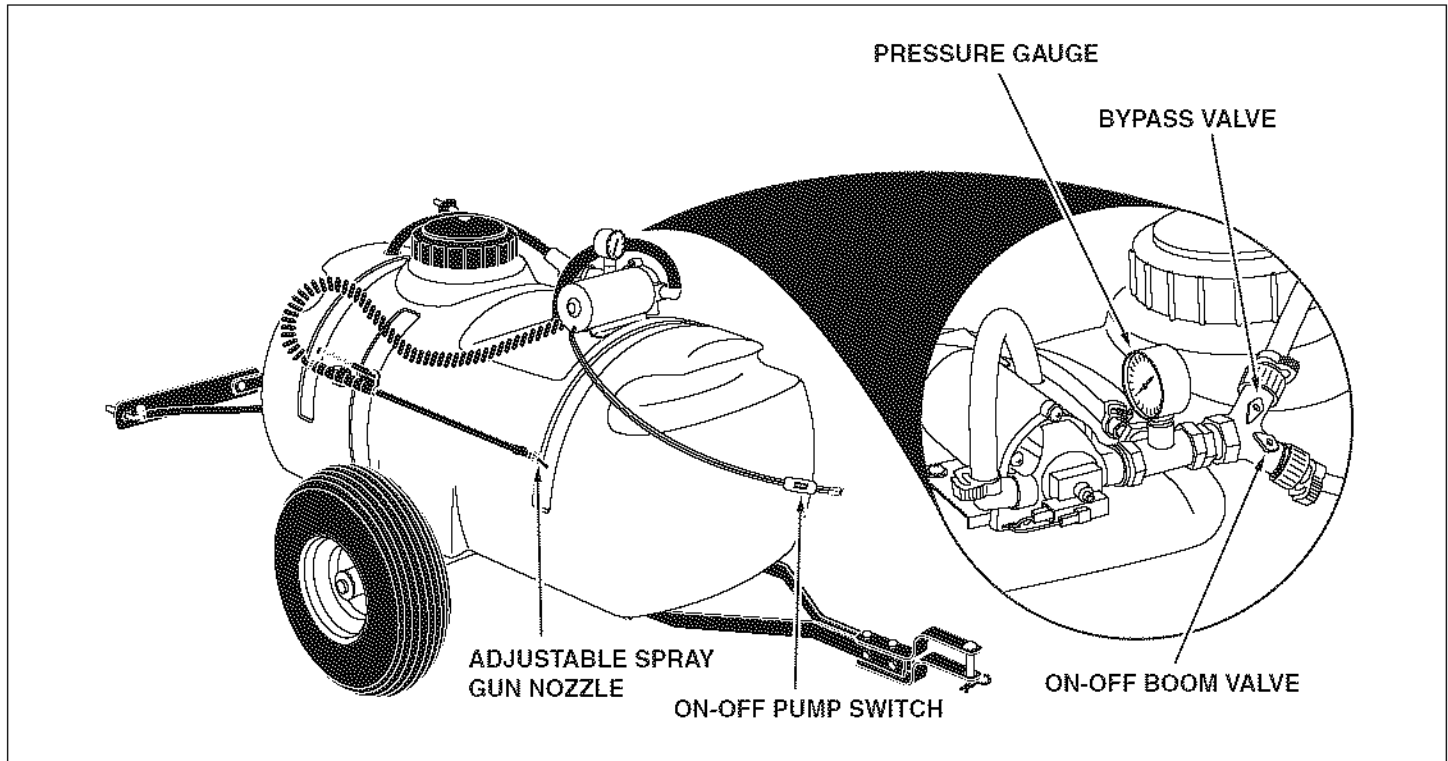

ON-OFF PUMP SWITCH Turns the pump motor on or off.

ADJUSTABLE SPRAY GUN NOZZLE Adjusts the spray from a cone shaped fine mist to a straight stream.

PRESSURE GAUGE Indicates the system operating pressure.

BYPASS VALVE Controls the operating pressure of the boom or spray gun.

ON-OFF BOOM VALVE Turns the boom nozzles on or off.

BEFORE STARTING

- It is important to test the boom and spray gun with plain water before using chemicals. This will enable you to check the sprayer for leaks and to set the spray pattern and nozzle pressure. If a leak should occur, thread tape may be used to better seal the leaking fitting.

HOW TO USE YOUR SPRAYER

BEFORE STARTING

It is **important** to test the boom and spray gun with plain water before using chemicals. This will enable you to check the sprayer for leaks and to set the spray pattern and nozzle pressure. If a leak should occur, thread tape may be used to better seal the fitting.

ON-OFF SWITCH

This switch is connected in line to the wiring assembly and is used by the operator to turn the pump motor on or off.

PUMP PRESSURE SWITCH

The pump is equipped with a pressure switch. The pressure switch senses outlet pressure of the pump and will turn off the electrical power to the pump at a predetermined high pressure point (60 PSI). If the flow demand is very low, the pump may reach this high pressure point and the switch will cause "cycling" (the pump cycles on and off rapidly). This is not a problem unless the pump is subject to continuous cycling within one second intervals for long periods of time.

ADJUSTING OPERATING PRESSURE

The sprayer is equipped with a "Y" fitting containing a bypass valve and a boom valve. The bypass valve controls the flow to the return (bypass) hose. The amount of flow through the return hose determines the operating pressure when the boom or the spray gun is in use. Adjust the bypass valve while either the boom or the spray gun is in use to obtain the desired pressure, indicated by the pressure gauge. The tip chart on page 9 shows how different pressure settings affect boom application rates.

ON-OFF ADJUSTMENT OF BOOM NOZZLES

The boom valve on the "Y" fitting controls flow to the boom nozzles. It should be either completely open or completely closed. The boom operating pressure can be controlled using the bypass valve on the "Y" fitting.

ADJUSTING SPRAY GUN NOZZLE

Turn the nozzle on the spray gun to adjust the spray from a cone shaped fine mist to a straight stream. Control the spray gun operating pressure with the bypass valve on the "Y" fitting. Maximum spray gun pressure can be attained when the boom is shut off.

SETTING THE BOOM FOR SPRAYING

The correct positioning of the boom places the nozzles approximately 40" apart and 14" above the ground. This gives a spray width of approximately 80" with a slight center overlap. See figure 11.

- Slide the boom bars out to the ends of the slots.
- Swivel the boom bars until the nozzles are approximately 14" above the ground.
- Make sure the nozzles are adjusted so that the openings point straight down.

USING THE SPRAYER

- Determine the application rate (gallons per 1,000 sq. feet or gallons per acre) based on the chemical manufacturers recommendations. Use this rate to help select the pressure setting and tractor speed in the following instructions.
- Determine the approximate square footage of the area to be sprayed and estimate the number of gallons required. This can help avoid unneeded solution left in the tank.
- Determine the appropriate speed at which to travel, based on the chosen pressure setting and the recommended application rate. Use the tip chart on page 9.
- To determine the throttle setting for attaining the appropriate speed, mark off 100, 200 and 300 feet intervals. The speed chart at the bottom of page 9 indicates the number of seconds it takes to travel these distances. Set the throttle and, with a running start, travel the distances in the number of seconds indicated by the speed chart. Once you have determined the throttle and gear settings needed, mark the throttle location so that you can easily resume the same speed after stopping.
- Set the operating pressure. Spray with plain water to help determine the best setting. For best results stay in the 20 to 30 PSI range. (At 10 PSI the spray pattern begins to break up, at 40 PSI some drift develops.) Refer to the tip chart on page 9.
- Add the chemical solution to the tank, following the product instructions.
- Drive to the starting place for spraying. Set the boom in position for spraying. Set the throttle at the position determined in step 4. Flip the sprayer's in-line switch to the "ON" position to start spraying.
- Stay clear of flowers, shrubs and evergreen trees when spraying weed control solutions to prevent contact of the solution with these sensitive plants.



CAUTION: WEAR EYE PROTECTION, GLOVES AND PROTECTIVE CLOTHING WHEN HANDLING AND WORKING WITH LAWN CHEMICALS.

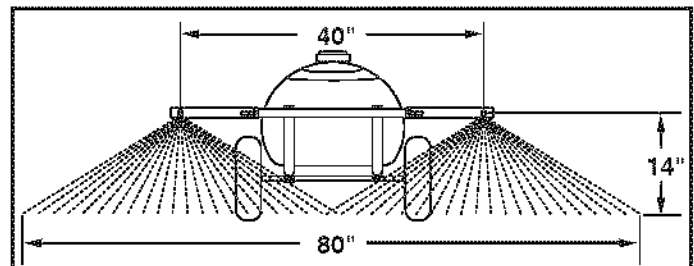

FIGURE 11

U.S. GALLON TIP CHART

Tip No.	Spray Height Inches	Pressure PSI	Tip Capacity US Gallons Per Minute	GALLONS PER ACRE (BASED ON WATER)						
				1 MPH	2 MPH	3 MPH	4 MPH	5 MPH	7.5 MPH	10 MPH
		10	.30	44.2	22.1	14.8	11.1	8.9	5.9	4.4
#3	13"	20	.42	63	31.5	20.9	15.7	12.6	8.4	6.3
		30	.52	76.8	38.4	25.8	19.3	15.4	10.3	7.7
Tip No.	Spray Height Inches	Pressure PSI	Tip Capacity US Gallons Per Minute	GALLONS PER 1000 SQ. FT. (BASED ON WATER)						
				1 MPH	2 MPH	3 MPH	4 MPH	5 MPH	7.5 MPH	10 MPH
		10	.30	1.0	0.50	0.34	0.26	0.20	0.14	0.10
#3	13"	20	.42	1.4	0.72	0.48	0.35	0.29	0.19	0.14
		30	.52	1.8	0.88	0.59	0.44	0.35	0.24	0.18

IMPERIAL GALLON (LITER) TIP CHART

Tip No.	Spray Height Inches (mm)	Pressure PSI (Bar)	Tip Capacity Imperial Gallons per minute (liters per minute)	IMPERIAL GALLONS (Liters) PER ACRE (BASED ON WATER)						
				1 MPH 1.6 K/H	2 MPH 3.2 K/H	3 MPH 4.8 K/H	4 MPH 6.4 K/H	5 MPH 8 K/H	7.5 MPH 12 K/H	10 MPH 16 K/H
		10 (0.7)	.25 (1.135)	36.8 (167.3)	18.4 (83.6)	12.3 (56.0)	9.2 (42.0)	7.4 (33.7)	4.9 (22.3)	3.7 (16.7)
#3	13" (330 mm)	20 (1.4)	.35 (1.59)	52.5 (238.5)	26.2 (119.2)	17.4 (79.1)	13.1 (59.4)	10.5 (47.7)	7.0 (31.8)	5.2 (23.8)
		30 (2.1)	.433 (1.97)	64.0 (290.7)	32.0 (145.3)	21.5 (97.7)	16.1 (73.1)	12.8 (58.3)	8.6 (39.0)	6.4 (29.1)
Tip No.	Spray Height Inches (mm)	Pressure PSI (Bar)	Tip Capacity Imperial Gallons per minute (liters per minute)	IMPERIAL GALLONS (Liters) PER 1000 SQ. FT. (BASED ON WATER)						
				1 MPH 1.6 K/H	2 MPH 3.2 K/H	3 MPH 4.8 K/H	4 MPH 6.4 K/H	5 MPH 8 K/H	7.5 MPH 12 K/H	10 MPH 16 K/H
		10 (0.7)	.25 (1.135)	0.85 (3.85)	0.42 (1.92)	0.28 (1.29)	0.21 (0.97)	0.17 (0.77)	0.11 (0.51)	0.08 (0.38)
#3	13" (330 mm)	20 (1.4)	.35 (1.59)	1.21 (5.48)	0.60 (2.74)	0.40 (1.82)	0.30 (1.37)	0.24 (1.10)	0.16 (0.73)	0.12 (0.55)
		30 (2.1)	.433 (1.97)	1.47 (6.68)	0.74 (3.34)	0.49 (2.24)	0.37 (1.68)	0.29 (1.34)	0.20 (0.90)	0.15 (0.67)

GROUND SPEED CHART

M.P.H. (K/H)	Time Required in Seconds to Travel a Distance of:		
	100 ft (30.5 M)	200 ft (61 M)	300 ft (91.5 M)
1.0 (1.6)	68	136	205
2.0 (3.2)	34	68	102
3.0 (4.8)	23	45	68
4.0 (6.4)	17	34	51
5.0 (8.0)	14	27	41
6.0 (9.7)	11	23	34
7.0 (11.3)	9.7	19	29
8.0 (12.9)	8.5	17	26
9.0 (14.5)	7.6	15	23
10.0 (16.1)	6.8	14	20

MAINTENANCE

CUSTOMER RESPONSIBILITIES

- Read and follow the maintenance schedule and the maintenance procedures listed in this section.

MAINTENANCE SCHEDULE Fill in dates as you complete regular service.	Service Dates											
	Before each use	After each use	Every season	Before storage								
Check for loose fasteners	X											
Flush the tank		X										
Cleaning the strainers			X									
Lubrication			X									

CHECK FOR LOOSE FASTENERS

- Before each use make a thorough visual check of the sprayer for any bolts and nuts which may have loosened. Retighten any loose bolts and nuts.

FLUSH THE TANK

- Remove any solution left in tank. Fill the sprayer part way with water, start the sprayer and allow clear water to be pumped through the plumbing system and out through the boom assembly and the handgun. Use the handgun to thoroughly wash all internal parts of the tank, the outside of the tank and the boom.
- Refill the tank about half full with plain water and a chemical neutralizer and repeat the cleaning instructions above. Flush the entire sprayer with the neutralizing agent. Follow the chemical manufacturers instructions for disposal of all wash or rinsing water.

CLEANING THE STRAINERS

- At least once a season, clean the strainer in the end of the intake hose at the bottom of the tank. Remove the nylon swivel nut from the hose, pull out the screen and flush it with clear water.
- At least once a season, clean the strainers in the boom nozzles. Remove the nozzle, pull out the screen and flush it with clear water.

LUBRICATION

- Apply a few drops of oil to the wheel hubs at least once a year.

STORAGE

STORAGE RECOMMENDATIONS

- Drain all water out of the sprayer, paying special attention to the pump and handgun. These items are especially prone to damage from chemicals and freezing weather.
- The sprayer should be winterized before storage by pumping a 50-50 solution of water and R. V. antifreeze through the entire plumbing. Proper care and maintenance will prolong the life of the sprayer.

IMPORTANT: Do not allow chemicals to sit in pump for extended times of idleness. Some chemicals will damage the pump valve if allowed to soak untreated for a length of time. Always flush the pump with water after each use. Follow the procedures in the Maintenance section for flushing and disposal.

TROUBLESHOOTING

PROBLEM	CAUSE	CORRECTION
Pump motor cycles on and off rapidly. (OK for short periods of time)	System pressure is reaching maximum setting of pump's pressure switch.	Decrease the system pressure by increasing the opening of the bypass valve.
Pressure too low	1. Bypass valve open too far. 2. Tank strainer dirty.	1. Decrease opening of bypass valve 2. Remove strainer and clean.
Pressure OK but boom spray weak.	Nozzles strainers dirty.	Remove strainers and clean.
Boom spray pattern does not overlap enough in the middle.	1. Nozzles set too low. 2. Nozzles don't point straight down.	1. Adjust boom arms. See page 9. 2. Rotate nozzle opening down.

NOTES

PARTS

REPAIR PARTS FOR 25 GALLON 70 PSI SPRAYER MODEL 486.245332

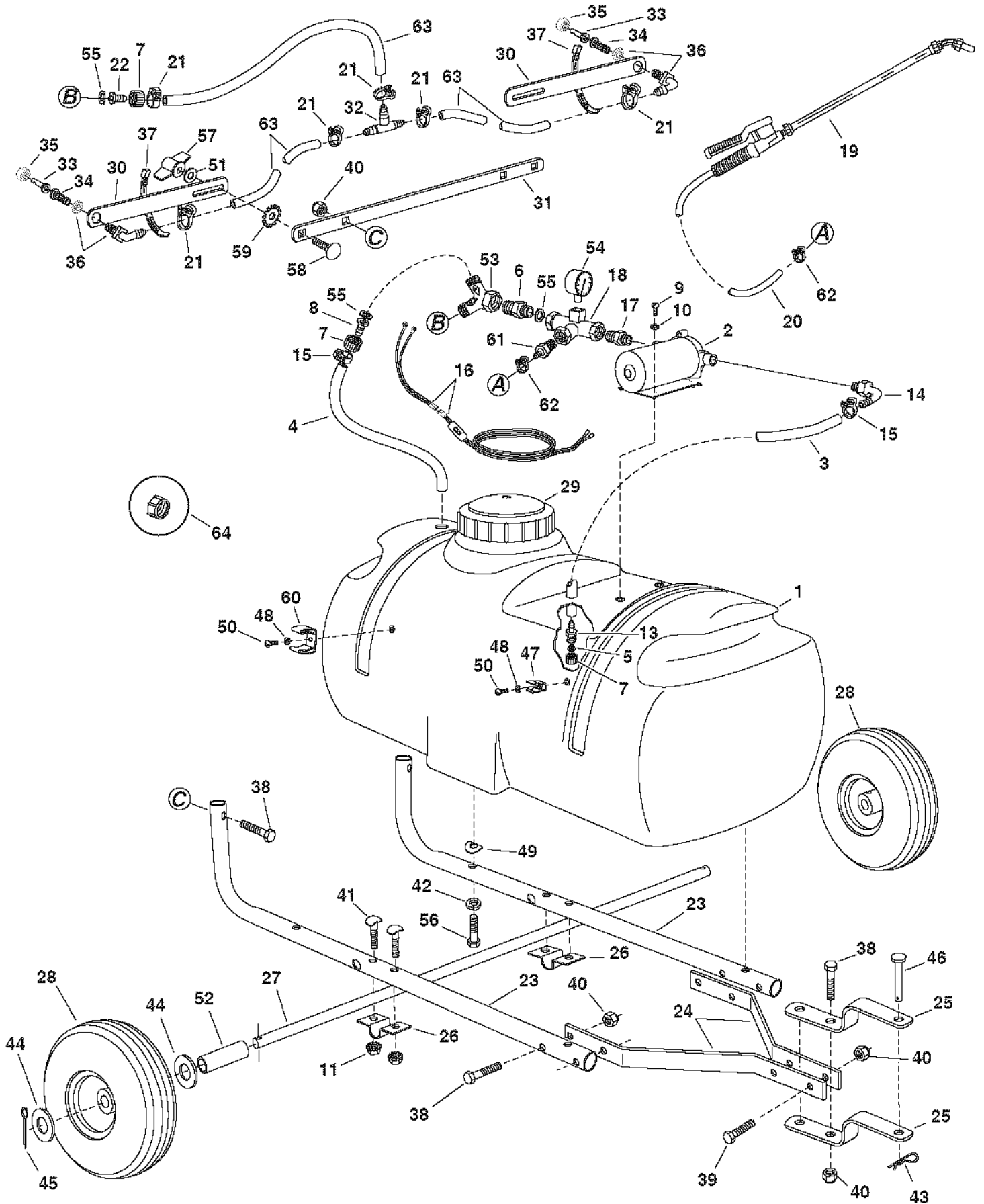

REPAIR PARTS FOR 25 GALLON 70 PSI SPRAYER MODEL 486.245332

REF. NO.	PART NO.	QTY.	DESCRIPTION	REF. NO.	PART NO.	QTY.	DESCRIPTION
1	46283	1	Tank (25 Gal.)	34	45029	2	Strainer, Screen Type
2	45015	1	Pump and Motor	35	45037	2	Nut, Screen Body
3	46278	1	Hose, 1/2" ID (24" Lg.)	36	47396	2	Elbow, Plastic 11/16" Thd.
4	45021	1	Hose, 1/2" ID (20" Lg.)	37	726-0178	2	Nylon Tie
5	45024	1	Strainer, Cap Type 1"	38	44180	8	Bolt, Hex 5/16-18 x 2"
6	45031	1	Adapter, 1/2" NPT x Hose	39	43840	2	Bolt, Hex 5/16-18 x 1-1/4"
7	45032	3	Nut, Swivel 3/4" Garden Hose	40	47810	10	Nut, Nylock 5/16-18
8	45033	1	Hose Barb, 1/2"	41	44947	4	Bolt, Curved Head 5/16-18 x 1-5/8"
9	45069	4	Screw, Ph. Pan Hd. 10-24 x 1" Lg.	42	43086	4	Lock Washer, 5/16"
10	43910	4	Washer, Flat #10 SAE	43	43343	1	Pin, Hair Cotter #4 (1/8")
11	46980	4	Nut, Hex 5/16-18 (SEMS)	44	43009	4	Washer, 3/4"
12	45085	2	Terminal, .25 Male Tab (not shown)	45	43093	2	Cotter Pin, 1/8" x 1-1/2"
13	46276	1	Adapter, 3/4" GH x 1/2" Barb	46	47623	1	Hitch Pin
14	46277	1	Elbow, 3/8 NPT x 1/2" Barb	47	45180	1	Hose Clip, Small
15	45025	2	Clamp, 1/2" Hose (For Black Hose)	48	736-0722	2	Lock Washer, #10
	45026	2	Clamp, 3/8" Hose (For Clear Hose)	49	44695	4	Washer, Bowed
16	49754	1	Switch and Wire Assembly	50	46677	2	Screw, Phillips Hd. #10-24 x 3/8"
17	45049	1	Nipple, (Nylon) 1/2" x 3/8" Red.	51	43081	2	Washer, 5/16" Std. Wrt.
18	45050	1	Tee, 1/2" x 1/2" x 1/2" (1/4" Port)	52	45151	2	Spacer
19	47406	1	Spray Gun	53	45017	1	Hose "Y" W / Valves 3/4"
20	49761	1	Hose, 1/4" ID (15' Lg)	54	45071	1	Gauge, Pressure 2" 100 PSI
21	45026	6	Clamp, 3/8" Hose (For Black Hose)	55	45072	3	Gasket, 3/4" Garden Hose
	47405	6	Clamp, 1/4" Hose (For Clear Hose)	56	43085	4	Bolt, Hex 5/16-18 x 1-1/2"
22	45034	1	Hose Barb, 3/8"	57	712-0421	2	Knob
23	48296	2	Frame Tube	58	43682	2	Bolt, Carriage 5/16-18 x 1-1/4"
24	24860	2	Hitch Arm	59	44732	2	Washer, Tooth Lock 5/16"
25	23014	2	Hitch Bracket	60	47397	1	Hose Clip (Large)
26	23917	2	Clamp, 3/4" Axle	61	47390	1	Adapter, 1/2" NPT x 1/4" Barb
27	24615	1	Axle, 3/4"	62	49779	2	Clamp, Coiled Hose
28	44456	2	Wheel	63	47392	3	Hose, 3/8" ID (20" Lg.)
29	46700	1	Lid	64	48719	1	Drain Cap
30	24122	2	Boom Bar		40171	1	Owners Manual
31	24585	1	Bracket, Boom Mount				
32	47394	1	Tee, Plastic 3/8" Hose				
33	45028	2	Nozzle, SS Floodjet				

Get it fixed, at your home or ours!

Your Home

For repair – **in your home** – of **all** major brand appliances, lawn and garden equipment, or heating and cooling systems, **no matter who made it, no matter who sold it!**

For the replacement parts, accessories and owner's manuals that you need to do-it-yourself.

For Sears professional installation of home appliances and items like garage door openers and water heaters.

1-800-4-MY-HOME® (1-800-469-4663)

Call anytime, day or night (U.S.A. and Canada)

www.sears.com www.sears.ca

Our Home

For repair of carry-in items like vacuums, lawn equipment, and electronics, call or go on-line for the location of your nearest

Sears Parts & Repair Center.

1-800-488-1222

Call anytime, day or night (U.S.A. only)

www.sears.com

To purchase a protection agreement (U.S.A.) or maintenance agreement (Canada) on a product serviced by Sears:

1-800-827-6655 (U.S.A.)

1-800-361-6665 (Canada)

Para pedir servicio de reparación a domicilio, y para ordenar piezas:

1-888-SU-HOGAR®

(1-888-784-6427)

Au Canada pour service en français:

1-800-LE-FOYER^{MC}

(1-800-533-6937)

www.sears.ca

The Sears logo is displayed in a large, bold, black serif font. The word "Sears" is written in a classic, slightly stylized typeface. Below the letters, there is a thin, horizontal, curved line that tapers at both ends, resembling a swoosh or a stylized underline.