

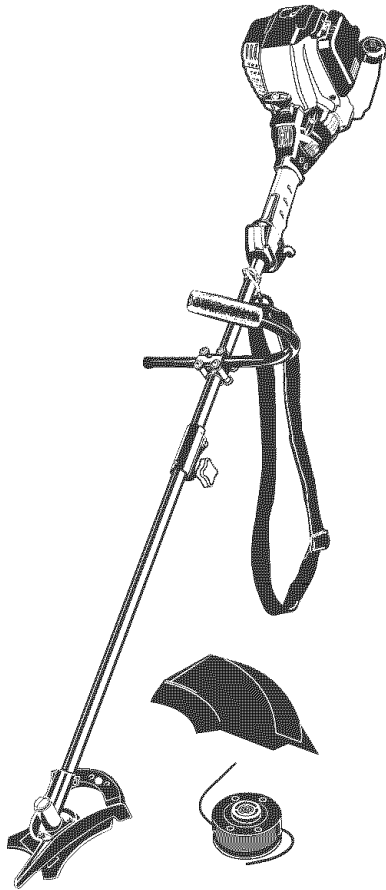

Operator's Manual

4-Cycle Gasoline Trimmer/Brushcutter TB590BC

SAVE THESE INSTRUCTIONS



For service call **1-800-520-5520** to obtain a list of authorized service dealers near you. For more details about your unit, visit our website at www.troybilt.com.

DO NOT RETURN THE UNIT TO THE RETAILER. PROOF OF PURCHASE WILL BE REQUIRED FOR WARRANTY SERVICE.



THIS PRODUCT IS COVERED BY ONE OR MORE U.S. PATENTS. OTHER PATENTS PENDING.

Service on this unit both within and after the warranty period should be performed only by an authorized and approved service dealer.

SPARK ARRESTOR NOTE

NOTE: For users on U.S. Forest Land and in the states of California, Maine, Oregon and Washington. All U.S. Forest Land and the state of California (Public Resources Codes 4442 and 4443), Oregon and Washington require, by law that certain internal combustion engines operated on forest brush and/or grass-covered areas be equipped with a spark arrestor, maintained in effective working order, or the engine be constructed, equipped and maintained for the prevention of fire. Check with your state or local authorities for regulations pertaining to these requirements. Failure to follow these requirements could subject you to liability or a fine. **This unit is factory equipped with a spark arrestor.** If it requires replacement, ask your LOCAL SERVICE DEALER to install the **Accessory Part #753-05297 Spark Arrestor Kit.**

CALIFORNIA PROPOSITION 65 WARNING

WARNING

THE ENGINE EXHAUST FROM THIS PRODUCT CONTAINS CHEMICALS KNOWN TO THE STATE OF CALIFORNIA TO CAUSE CANCER, BIRTH DEFECTS OR OTHER REPRODUCTIVE HARM.

TABLE OF CONTENTS

Service Information	1
Rules for Safe Operation	2
Know Your Unit	4
Assembly Instructions	4
Oil and Fuel Information	6
Starting/Stopping Instructions	7
Operating Instructions	8
Maintenance and Repair Instructions	10
Cleaning and Storage	16
Troubleshooting Chart	17
Specifications	18
Warranty Information	19
Parts List	Inside Back Cover

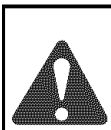

WARNING: When using the unit, you must follow the safety rules. Please read these instructions before operating the unit in order to ensure the safety of the operator and any bystanders. Please keep these instructions for later use.

All information, illustrations, and specifications in this manual are based on the latest product information available at the time of printing. We reserve the right to make changes at any time without notice.

Copyright© 2005 MTD SOUTHWEST INC, All Rights Reserved.

RULES FOR SAFE OPERATION

• IMPORTANT SAFETY INSTRUCTIONS •

READ ALL INSTRUCTIONS BEFORE OPERATING

- Read the instructions carefully. Be familiar with the controls and proper use of the unit.
- Do not operate this unit when tired, ill, or under the influence of alcohol, drugs, or medication.
- Children and teens under the age of 15 must not use the unit, except for teens guided by an adult.
- All guards and safety attachments must be installed properly before operating the unit.
- Inspect the unit before use. Replace damaged parts. Check for fuel leaks. Make sure all fasteners are in place and secure. Replace parts that are cracked, chipped, or damaged in any way. Do not operate the unit with loose or damaged parts.
- Carefully inspect the area before starting the unit. Remove all debris and hard or sharp objects such as glass, wire, etc.
- Be aware of the risk of injury to the head, hands and feet.
- Clear the area of children, bystanders, and pets. At a minimum, keep all children, bystanders, and pets outside a 50 feet (15 m.) radius; there still may be a risk to bystanders from thrown objects. Bystanders should be encouraged to wear eye protection. If you are approached, stop the unit immediately.
- Use only 0.105 inch, 2.67 mm diameter original equipment manufacturer replacement line. Never use metal-reinforced line, wire or rope. These can break off and become dangerous projectiles.
- Squeeze the throttle control and check that it returns automatically to the idle position. Make all adjustments or repairs before using unit.

SAFETY WARNINGS FOR GAS UNITS



WARNING: Gasoline is highly flammable, and its vapors can explode if ignited. Take the following precautions:

- Store fuel only in containers specifically designed and approved for the storage of such materials.
- Avoid creating a source of ignition for spilled fuel. Do not start the engine until fuel vapors dissipate.
- Always stop the engine and allow it to cool before filling the fuel tank. Never remove the fuel tank cap or add fuel when the engine is hot. Never operate the unit without the fuel cap securely in place. Loosen the fuel tank cap slowly to relieve any pressure in the tank.
- Add fuel in a clean, well-ventilated outdoor area where there are no sparks or flames. Remove the fuel cap slowly, and only after the engine stops. Do not smoke while fueling. Wipe up any spilled fuel from the unit immediately.
- Avoid creating a source of ignition for spilled fuel. Do not start the engine until fuel vapors dissipate.
- Move the unit at least 30 feet (9.1 m) from the fueling source and site before starting the engine. Do not smoke. Keep sparks and open flames away from the area while adding fuel or operating the unit.

WHILE OPERATING

- Never start or run the unit inside a closed room or building. Breathing exhaust fumes can be fatal. Operate this unit only in a well-ventilated outdoor area.
- Wear safety glasses or goggles that meet ANSI Z87.1 standards and are marked as such. Wear ear/hearing protection when operating this unit. Wear a face or dust mask if the operation is dusty.
- Wear heavy long pants, boots, gloves and a long sleeve shirt. Do not wear loose clothing, jewelry, short pants, sandals or go barefoot. Secure hair above shoulder level.
- The cutting attachment shield must always be in place while operating the unit as a trimmer. Do not operate unit without both trimming lines extended, and the proper line installed. Do not extend the trimming line beyond the length of the shield.

- This unit has a clutch. The cutting attachment remains stationary when the engine is idling. If it does not, have the unit adjusted by an authorized service technician.
- Adjust the handle to your size in order to provide the best grip.
- Be sure the cutting attachment is not in contact with anything before starting the unit.
- Use the unit only in daylight or good artificial light.
- Avoid accidental starting. Be in the starting position whenever pulling the starter rope. The operator and unit must be in a stable position while starting. Refer to Starting/Stopping Instructions.
- Use the right tool. Only use this tool for its intended purpose.
- Do not overreach. Always keep proper footing and balance.
- Always hold the unit with both hands when operating. Keep a firm grip on both handles or grips.
- Keep hands, face, and feet at a distance from all moving parts. Do not touch or try to stop the cutting attachment when it rotates.
- Do not touch the engine, gear housing or muffler. These parts get extremely hot from operation, even after the unit is turned off.
- Do not operate the engine faster than the speed needed to cut, trim or edge. Do not run the engine at high speed when not cutting.
- Always stop the engine when cutting is delayed or when walking from one cutting location to another.
- If you strike or become entangled with a foreign object, stop the engine immediately and check for damage. Do not operate before repairing damage. Do not operate the unit with loose or damaged parts.
- Stop the unit, switch the engine to off, and disconnect the spark plug for maintenance or repair.
- Use only original equipment manufacturer replacement parts and accessories for this unit. These are available from your authorized service dealer. Use of any unauthorized parts or accessories could lead to serious injury to the user, or damage to the unit, and void your warranty.
- Keep unit clean of vegetation and other materials. They may become lodged between the cutting attachment and shield.
- To reduce fire hazard, replace a faulty muffler and spark arrestor. Keep the engine and muffler free from grass, leaves, excessive grease or carbon build up.

WHILE OPERATING WITH CUTTING BLADE

- Read and understand all safety warnings before operating this unit.
- Always use the shoulder harness when using the brush blade accessory.
- Keep the J-handle between the operator and cutting attachment or blade at all times.
- NEVER cut when the cutting blade is 30 inches (76 cm) or more above the ground level.
- Blade thrust may occur when the spinning blade contacts an object that it does not immediately cut. Blade thrust can be violent enough to propel the unit and/or operator in any direction, possibly causing a loss of control. Blade thrust can occur without warning if the blade snags, stalls or binds. This is more likely to occur in areas where it is difficult to see the material being cut.
- For operation with the brush blade, do not cut anything thicker than 1/2 inch or a violent kickback could occur.
- Do not attempt to touch or stop the blade when it is rotating.
- A coasting blade can cause injury while it continues to spin after the engine is stopped or the throttle trigger is released. Maintain proper control until the blade has completely stopped rotating.

RULES FOR SAFE OPERATION







- Do not run the unit at high speed when not cutting.
- If you strike or become entangled with a foreign object, stop the engine immediately and check for damage. Have any damage repaired before attempting further operations. Do not operate unit with a bent, cracked or dull blade. Discard blades that are bent, warped, cracked or broken.
- Do not sharpen the cutting blade. Sharpening the blade can cause the blade tip to break off while in use. This can result in severe personal injury. Replace the blade.
- Do not use the cutting blade for edging or as an edger; severe personal injury to yourself or others may incur. Use the cutting blade only for the purpose described in this manual.
- Stop the engine IMMEDIATELY if you feel excessive vibration. Vibration is a sign of trouble. Inspect thoroughly for loose nuts, bolts or damage before continuing. Repair or replace affected parts as necessary.

After Use

- Clean cutting blades with a household cleaner to remove any gum buildup. Oil the blade with machine oil to prevent rust.
- Lock up and store the cutting blade in an appropriate area to protect the blade from unauthorized use or damage.

SAFETY AND INTERNATIONAL SYMBOLS



This operator's manual describes safety and international symbols and pictographs that may appear on this product. Read the operator's manual for complete safety, assembly, operating and maintenance and repair information.

SYMBOL	MEANING
	<ul style="list-style-type: none"> • SAFETY ALERT SYMBOL <p>Indicates danger, warning or caution. May be used in conjunction with other symbols or pictographs.</p>
	<ul style="list-style-type: none"> • WARNING - READ OPERATOR'S MANUAL <p>Read the operator's manual(s) and follow all warnings and safety instructions. Failure to do so can result in serious injury to the operator and/or bystanders.</p>
	<ul style="list-style-type: none"> • WEAR EYE AND HEARING PROTECTION <p>WARNING: Thrown objects and loud noise can cause severe eye injury and hearing loss. Wear eye protection meeting ANSI Z87.1 standards and ear protection when operating this unit. Use a full face shield when needed.</p>
	<ul style="list-style-type: none"> • HOT SURFACE WARNING <p>Do not touch a hot muffler, gear housing or cylinder. You may get burned. These parts get extremely hot from operation. They remain hot for a short time after the unit is turned off.</p>
	<ul style="list-style-type: none"> • UNLEADED FUEL <p>Always use clean, fresh unleaded fuel</p>
	<ul style="list-style-type: none"> • OIL <p>Refer to operator's manual for the proper type of oil.</p>
	<ul style="list-style-type: none"> • ON/OFF STOP CONTROL <p>ON / START / RUN</p>
	<ul style="list-style-type: none"> • ON/OFF STOP CONTROL <p>OFF or STOP</p>

OTHER SAFETY WARNINGS

- Never store a fueled unit inside a building where fumes may reach an open flame or spark.
- Allow the engine to cool before storing or transporting. Be sure to secure the unit while transporting.
- Store the unit in a dry area, locked up or up high to prevent unauthorized use or damage, out of the reach of children.
- Never douse or squirt the unit with water or any other liquid. Keep handles dry, clean and free from debris. Clean after each use, see Cleaning and Storage instructions.
- Keep these instructions. Refer to them often and use them to instruct other users. If you loan someone this unit, also loan them these instructions.

SAVE THESE INSTRUCTIONS

SYMBOL	MEANING
	<ul style="list-style-type: none"> • KEEP BYSTANDERS AWAY <p>WARNING: Keep all bystanders, especially children and pets, at least 50 feet (15 m) from the operating area.</p>
	<ul style="list-style-type: none"> • CHOKE CONTROL <ol style="list-style-type: none"> 1. • FULL choke position 2. • PARTIAL choke position 3. • RUN choke position
	<ul style="list-style-type: none"> • THROWN OBJECTS AND ROTATING CUTTER CAN CAUSE SEVERE INJURY <p>WARNING: Do not operate without the cutting attachment shield in place. Keep away from the rotating cutting attachment.</p>
	<ul style="list-style-type: none"> • SHARP BLADE <p>WARNING: Sharp blade on cutting attachment shield. To prevent serious injury, do not touch the line cutting blade.</p>
	<ul style="list-style-type: none"> • BRUSHCUTTERS • REPLACE DULL BLADE <p>Do not sharpen the cutting blade. Sharpening the blade can cause the blade tip to break off while in use. This can result in severe personal injury.</p>
	<ul style="list-style-type: none"> • TRIMMER/ BRUSHCUTTER SAFETY <p>WARNING: Thrown objects and rotating cutter can cause severe injury. Keep bystanders, especially children and pets, at least 50 feet (15 m) away from the cutting area. The cutting attachment shield must be used when using the trimmer cutting attachment.</p>

ASSEMBLY INSTRUCTIONS

KNOW YOUR UNIT

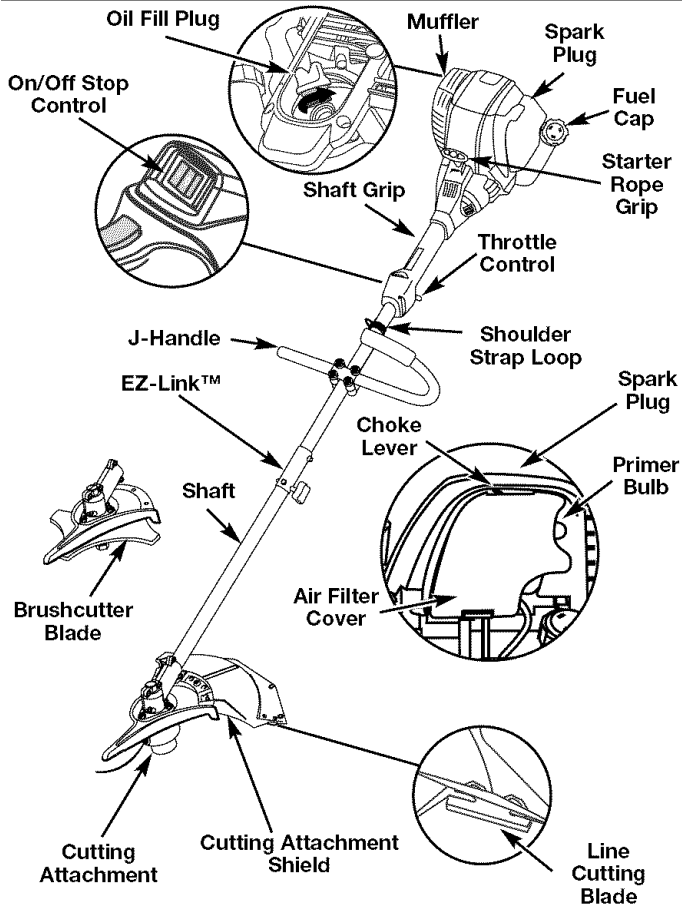

On some units, the J-handle may be pre-installed. In this case you must loosen screws and adjust the handle to fit the operator. Go to step 5 if the J-handle is pre-installed.

INSTALL AND ADJUST THE J-HANDLE

1. Place the J-handle between the top and middle clamp pieces (Fig. 1).
2. While holding the three pieces together, install the four (4) screws through the top clamp and into middle clamp.

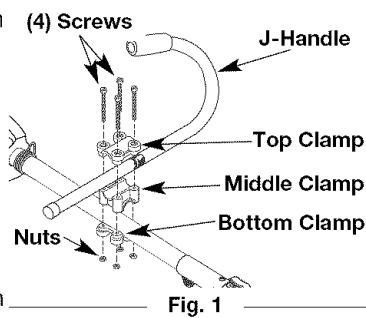

NOTE: The holes in the top and middle clamp will line up only when assembled correctly.

3. Place the clamps and the J-handle over the shaft housing and onto the bottom clamp.

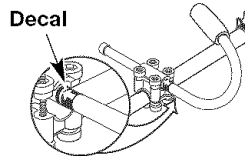

4. Hold each hex nut in the bottom clamp recess with a finger. Start screws with a large Phillips screwdriver. Do not tighten until you make the handle adjustment.
5. Slide the J-handle in or out until the arrow/white line on the decal touches the clamp assembly (Fig. 2). You must first loosen the screws if the handle is pre-installed.
6. While holding the unit in the operating position (Fig. 3), position the J-handle to the location that provides you the best grip.

7. Tighten the clamp screws evenly, until the J-handle is secure.

INSTALL THE HARNESS



WARNING: Always use the shoulder harness when using the cutting blade to avoid serious personal injury.

1. Push the strap through the center of the buckle.
2. Pull the strap over the cross bar and down through the slot in the buckle (Fig. 4).
3. Put the harness on over head and onto shoulder. Snap it on to the support fitting (Fig. 5).
4. Adjust length to fit the operator's size. Pull tab to lengthen, pull strap to shorten (Fig 6).

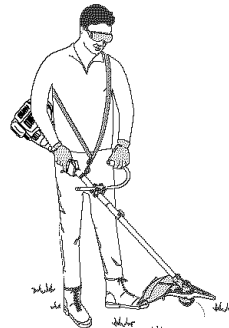

Fig. 3

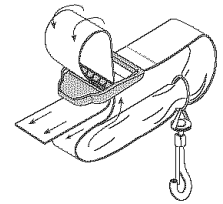

Fig. 4

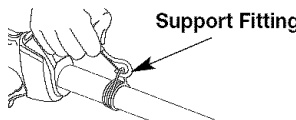

Fig. 5

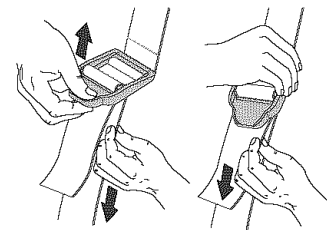

Fig. 6

REMOVE AND INSTALL THE CUTTING ATTACHMENT SHIELD



WARNING: The cutting attachment shield should NOT be installed when operating the unit with a blade. Remove the cutting attachment shield before removing or installing the blade.

Remove the cutting attachment shield when using the unit as a brushcutter

Remove the cutting attachment shield from the shield mount by removing the three (3) screws with a flat blade screwdriver (Fig. 7). Store parts for future use.

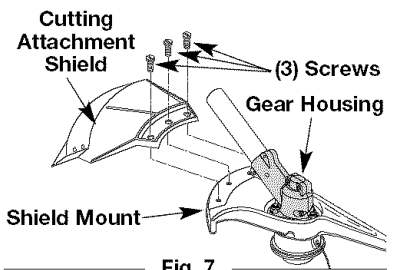

Fig. 7

Install the cutting attachment shield when using the unit as a grass trimmer



WARNING: To avoid serious personal injury, the cutting attachment shield MUST be in place at all times while operating the unit as a grass trimmer.

Install the cutting attachment shield on the shield mount by inserting the three (3) screws into the shield mount. Tighten securely with a flat blade screwdriver (Fig. 7).

REMOVE THE CUTTING ATTACHMENT AND INSTALL THE CUTTING BLADE

NOTE: To make cutting blade removal and installation easier, place the unit on the ground or on a work bench.

Remove the Cutting Attachment Shield

See Remove and Install the Cutting Attachment Shield.

ASSEMBLY INSTRUCTIONS



WARNING: The gear housing gets hot with use. It can result in injury to the operator. The housing remains hot for a short time even after the unit is turned off. Do not touch the gear housing until it has cooled.

Remove the Cutting Attachment

1. Align the shaft bushing hole with the locking rod slot and insert the locking rod into the shaft bushing hole (Fig. 8).
2. Hold the locking rod in place by grasping it next to the boom of the unit (Fig. 9).
3. While holding the locking rod, remove the cutting attachment by turning it clockwise off of the output shaft (Fig. 10). Store the cutting attachment for future use.

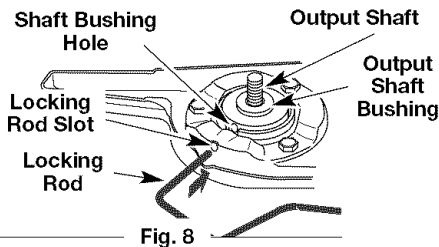

Fig. 8

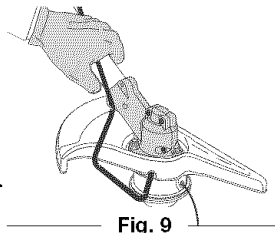

Fig. 9

NOTE: The blade retainer under the cutting attachment will be used when installing the cutting blade.

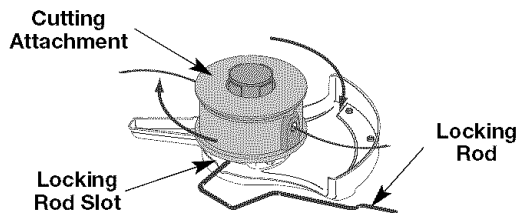

Fig. 10



WARNING: To avoid serious personal injury, always wear gloves while handling or installing the blade.

Install the Cutting Blade

4. Place the cutting blade on the output shaft bushing (Fig. 11).
5. Make sure that the cutting blade is centered on the pilot step and sitting flat against the output shaft bushing (Fig. 11).
6. Align the shaft bushing hole with the locking rod slot and insert the locking rod into the bushing hole (Fig. 8).

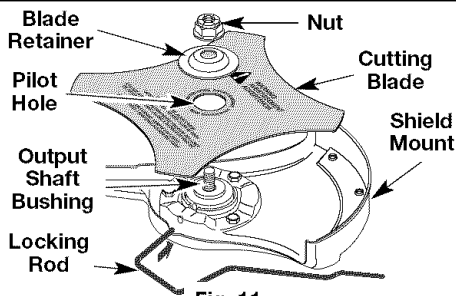

Fig. 11



WARNING: If the cutting blade is off-center, the unit will vibrate and the blade may fly off, causing possible serious personal injury.

7. Put the blade retainer and nut on the output shaft. Make sure that the blade is installed correctly.
 8. Tighten nut counterclockwise against the blade while holding the locking rod:
- If using a torque wrench and a 13 mm socket tighten to: **325 - 335 in•lb, 27 - 28 ft•lb, 37 - 38 N•m.**

- Without a torque wrench, use a 13 mm closed-end or socket wrench, turning the nut until the blade retainer is snug against the shaft bushing. Make sure that the blade is installed correctly, then rotate the nut an additional 1/4 to 1/2 turn counterclockwise (Fig. 13).

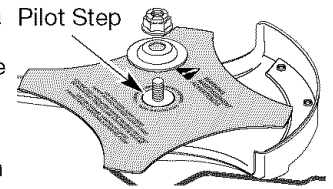

Fig. 12

9. Remove the locking rod from the locking rod slot.

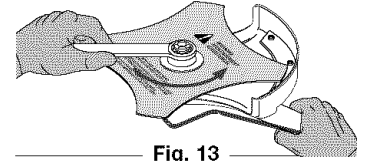

Fig. 13



WARNING: To avoid serious personal injury or damage to the unit, do not start or operate this unit with the locking rod in the locking rod slot.



WARNING: Do not sharpen the cutting blade. Sharpening the blade can cause the blade tip to break off while in use. This can result in severe personal injury. Replace the blade.

REMOVE THE CUTTING BLADE AND INSTALL THE CUTTING ATTACHMENT

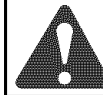

WARNING: To avoid serious personal injury, always wear gloves while handling or installing the blade.

Remove the Cutting Blade

1. Align the shaft bushing hole with the locking rod slot and insert the locking rod into the bushing hole (Fig. 8).
2. Hold the locking rod in place by grasping it next to the boom of the unit (Fig. 14).
3. While holding the locking rod, loosen the nut on the blade by turning it clockwise with a 13 mm closed-end or socket wrench (Fig. 14).
4. Remove the nut, blade retainer and blade. Store the nut and blade together for future use in a secure place. Store out of children's reach.

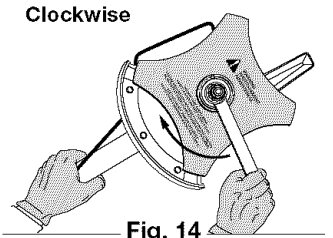

Fig. 14

Install the Cutting Attachment

5. Align the shaft bushing hole with the locking rod slot and insert the locking rod into the shaft bushing hole (Fig. 8). Place the blade retainer on the output shaft with the flat surface against the output shaft bushing (Fig. 15). Screw the cutting attachment counterclockwise onto the output shaft. Tighten securely.

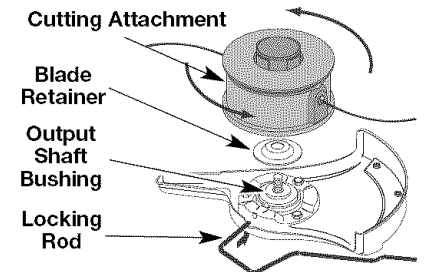

Fig. 15

NOTE: The blade retainer must be installed on the output shaft in the position shown for the cutting attachment to work correctly.

6. Remove the locking rod.
7. Install the cutting attachment shield. Refer to *Remove and Install the Cutting Attachment Shield*.

OIL AND FUEL INFORMATION



WARNING: To avoid serious personal injury, the cutting attachment shield **MUST** be in place at all times while operating the unit as a trimmer.



WARNING: OVERFILLING OIL CRANKCASE MAY CAUSE SERIOUS PERSONAL INJURY. Check and maintain the proper oil level in the crank case; it is important and cannot be overemphasized. Check the oil before each use and change it as needed. See *Changing the Oil*.

RECOMMENDED OIL TYPE

Using the proper type and weight of oil in the crankcase is extremely important. Check the oil before each use and change the oil regularly. Failure to use the correct oil, or using dirty oil, can cause premature engine wear and failure.

Use a high-quality SAE 30 weight oil of API (American Petroleum Institute) service class SF, SG, SH.

ADDING OIL TO CRANKCASE: INITIAL USE

NOTE: This unit is shipped without oil. In order to avoid damage to the unit, put oil in the crankcase before you attempt to start the unit.

Your unit is supplied with one 3.04 fluid oz. (90 ml.) bottle of SAE 30 SF, SG, SH oil (Fig. 16).

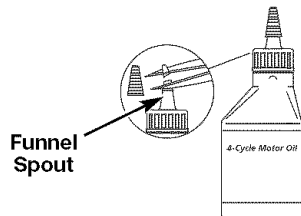

Fig. 16

NOTE: Save the bottle of oil. It can be used to measure the correct amount during future oil changes. See *Changing the Oil*.

1. Unscrew the top of the bottle of oil and remove the paper seal covering the opening. Replace the top. Next, cut the tip off the funnel spout (Fig. 16).
2. Tip unit so that the back of the engine is facing up in a vertical position.
3. Remove the oil fill plug from the crankcase (Fig. 17).

4. Pour the entire bottle of oil into the oil fill hole (Fig. 18).

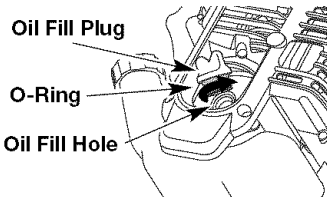

Fig. 17

NOTE: Never add oil to the fuel or fuel tank.

5. Wipe up any oil that may have spilled and reinstall the oil fill plug.

Check oil before each use and change as needed. Refer to *Checking the Oil Level*.

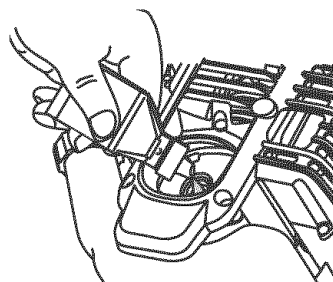

Fig. 18

RECOMMENDED FUEL TYPE

Old fuel is the primary reason for improper unit performance. Be sure to use fresh, clean, unleaded gasoline.

NOTE: This is a four cycle engine. In order to avoid damage to the unit, **do not mix oil with gasoline**.

Definition of Blended Fuels

Today's fuels are often a blend of gasoline and oxygenates such as ethanol, methanol or MTBE (ether). Alcohol-blended fuel absorbs water. As little as 1% water in the fuel can make fuel and oil separate or form acids when stored. Use fresh fuel (less than 60 days old), when using alcohol-blended fuel.

Using Blended Fuels

If you choose to use a blended fuel, or its use is unavoidable, follow recommended precautions:

- Always use fresh unleaded gasoline
- Use the fuel additive STA-BIL® or an equivalent
- Drain tank and run the engine dry before storing unit

Using Fuel Additives



WARNING: Add fuel in a clean, well ventilated outdoor area. Wipe up any spilled fuel immediately. Avoid creating a source of ignition for spilt fuel. Do not start the engine until fuel vapors dissipate.

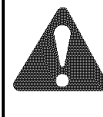

WARNING: Gasoline is extremely flammable. Ignited vapors may explode. Always stop the engine and allow it to cool before filling the fuel tank. Do not smoke while filling the tank. Keep sparks and open flames at a distance from the area.

The use of fuel additives, such as STA-BIL® Gas Stabilizer or an equivalent, will inhibit corrosion and minimize the formation of gum deposits. Using a fuel additive can keep fuel from forming harmful deposits in the carburetor for up to six (6) months. Add 0.8 oz. (23 ml.) of fuel additive per gallon of fuel according to the instructions on the container. NEVER add fuel additives directly to the unit's gas tank.

FUELING THE UNIT



WARNING: Remove fuel cap slowly to avoid injury from fuel spray. Never operate the unit without the fuel cap securely in place.

1. Remove the fuel cap (Fig. 19).
2. Place the gas container's spout into the fill hole on the fuel tank (Fig. 19) and fill the tank.

NOTE: Do not overfill the tank.

3. Wipe up any gasoline that may have spilled.
4. Reinstall the fuel cap.
5. Move the unit at least 30 ft. (9.1 m) from the fueling source and site before starting the engine.

NOTE: Dispose of the old gasoline in accordance to Federal, State and Local regulations.

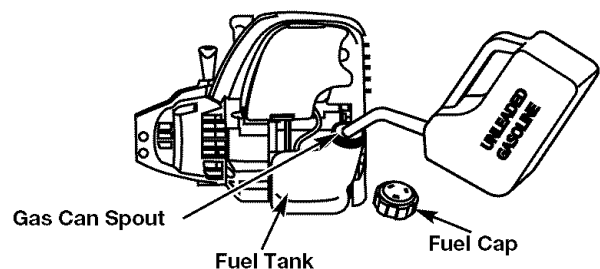

Fig. 19

STARTING/STOPPING INSTRUCTIONS



WARNING: Operate this unit only in a well-ventilated outdoor area. Carbon monoxide exhaust fumes can be lethal in a confined area.



WARNING: Avoid accidental starting. Make sure you are in the starting position when pulling the starter rope (Fig. 8). To avoid serious injury, the operator and unit must be in a stable position while starting. To avoid serious personal injury, ensure any Add-On being used is installed correctly and secure before starting the unit.

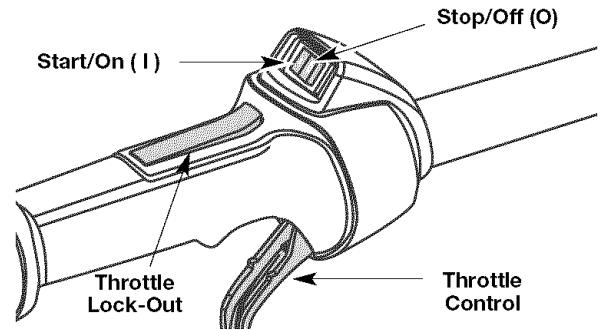

Fig. 20

STARTING INSTRUCTIONS

1. Check the oil level in the crankcase. Refer to Checking the Oil Level.
2. Fill the fuel tank with fresh, clean unleaded gasoline. Refer to Fueling the Unit.
3. Make sure the On/Off Stop Control in the ON (I) position (Fig. 20).
4. Fully press and release the primer bulb 10 times, slowly. Some amount of **fuel should be visible in the primer bulb and fuel lines** (Fig. 21). If you can't see fuel in the bulb, press and release the bulb as many times as it takes before you can see fuel in it.
5. Place the choke lever in **Position 1** (Fig. 21).
6. Crouch in the starting position (Fig. 22). Press the throttle lockout in and squeeze the throttle control lever. Pull the starter rope briskly 5 times.
7. Place the choke lever in **Position 2** (Fig. 21).
8. While pressing the throttle lockout in and squeezing the throttle control , pull the starter rope briskly 1 to 4 times to start the engine.
9. Keep the throttle squeezed and allow the engine to warm up for 15 to 30 seconds.
10. Place the choke lever in **Position 3** (Fig. 21). The unit is ready for use.

IF... The engine does not start, go back to step 4.

IF... The engine fails to start after a few attempts, place the choke lever in **Position 3**, press the throttle lockout in and squeeze the throttle control. Pull the starter rope briskly 3 to 8 times. The engine should start. If not, repeat.

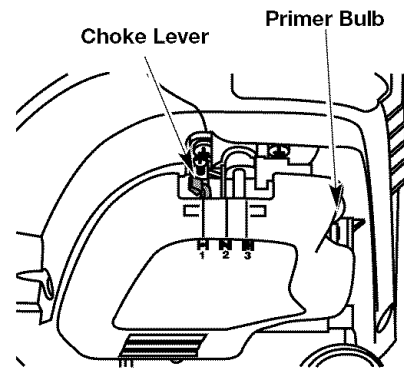

Fig. 21

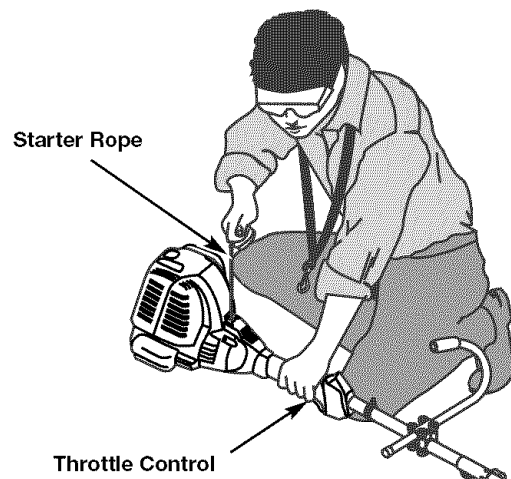

Fig. 22

STOPPING INSTRUCTIONS

1. Release your hand from the throttle control. Allow the engine to cool down by idling.
2. Press the On/Off Stop Control switch in the OFF (O) position.

OPERATING INSTRUCTIONS

OPERATING THE EZ-LINK™ SYSTEM

The EZ-Link™ system enables the use of these optional Add-Ons:

Cultivator	TBGC
Edger	TBLE
Hedge Trimmer	TBAH
Straight Shaft Trimmer	TBSS
Turbo Blower	TBTB
Pole Saw	TBPS
Brushcutter	TBBC*

*Do NOT use this attachment with an electric powered unit.



WARNING: Before you begin using any attachment, read and understand the manual that came with the attachment. Follow all safety information contained within.

Removing the Cutting Attachment or Add-On

1. Turn the knob counterclockwise to loosen (Fig. 23).
2. Press and hold the release button (Fig. 23).
3. While firmly holding the upper shaft housing, pull the cutting attachment or add-on straight out of the EZ-Link™ coupler (Fig. 24).



WARNING: To avoid serious personal injury and damage to the unit, shut the unit off before removing or installing add-ons.

Installing the Cutting Attachment or Add-On

NOTE: Place the unit on the ground or on a work bench to make add-on installation or removal easier.

1. Turn knob counterclockwise to loosen (Fig. 23).

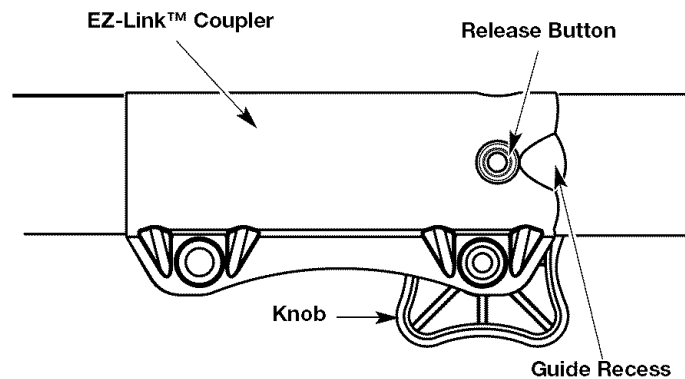

Fig. 23

2. While firmly holding the add-on, push it straight into the EZ-Link™ coupler (Fig. 24).

NOTE: Aligning the release button with the guide recess will help installation (Fig. 23).

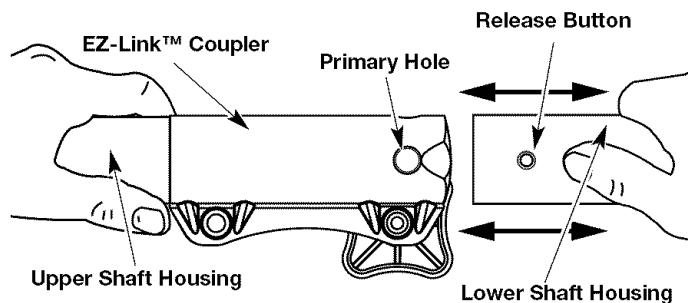



Fig. 24

3. Turn the knob clockwise to tighten (Fig. 25).



CAUTION: Lock the release button in the primary hole and securely tighten the knob before operating this unit.

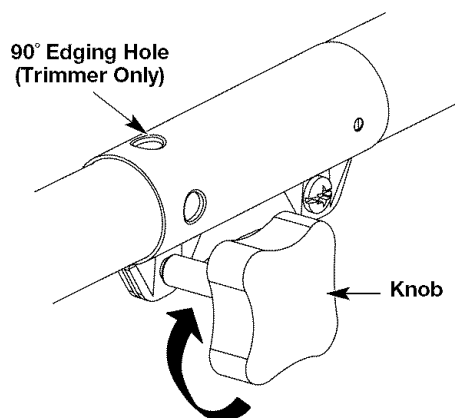



Fig. 25



CAUTION: Add-ons are to be used in the primary hole only. Using the wrong hole could lead to personal injury or damage to the unit.

For edging (when using the line head cutting attachment with EZ-Link™ models), lock the release button of the cutting attachment into the 90° edging hole (Fig. 25).

OPERATING INSTRUCTIONS

HOLDING THE TRIMMER



WARNING: Always wear eye, hearing, foot and body protection to reduce the risk of injury when operating this unit.

Before operating the unit, stand in the operating position (Fig. 26). Check for the following:

- The operator is wearing eye protection and proper clothing
- With a slightly-bent right arm, the operator's right hand is holding the shaft grip
- The operator's left arm is straight, the left hand holding the assist handle
- The unit is at waist level
- The cutting attachment is parallel to the ground and easily contacts the grass without the need to bend over



Fig. 26



WARNING: Do not remove or alter the line cutting blade assembly. Excessive line length will make the clutch overheat. This may lead to serious personal injury or damage to the unit.

ADJUSTING TRIMMING LINE LENGTH

The Bump Head™ cutting attachment allows you to release trimming line without stopping the engine. To release more line, lightly tap the cutting attachment on the ground (Fig. 27) while operating the trimmer at high speed.

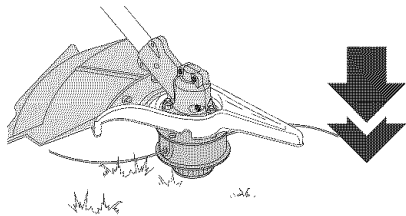

Fig. 27

NOTE: Always keep the trimming line fully extended. Line release becomes more difficult as the cutting line becomes shorter.

Each time the head is bumped, about 1 inch (25.4 mm) of trimming line is released. A blade in the cutting attachment shield will cut the line to the proper length if excess line is released.

For best results, tap the Bump Head™ on bare ground or hard soil. If line release is attempted in tall grass, the engine may stall. Always keep the trimming line fully extended. Line release becomes more difficult as the cutting line becomes shorter.

NOTE: Do not rest the Bump Head™ on the ground while the unit is running.

Some line breakage will occur from:

- Entanglement with foreign matter
- Normal line fatigue
- Attempting to cut thick, stalky weeds
- Forcing the line into objects such as walls or fence posts

TIPS FOR BEST TRIMMING RESULTS

- For best trimming results, operate unit at full throttle.
- Keep the cutting attachment parallel to the ground.
- Do not force the cutting attachment. Allow the tip of the line to do the cutting, especially along walls. Cutting with more than the tip will reduce cutting efficiency and may overload the engine.
- Cut grass over 8 inches (200 mm) by working from top to bottom in small increments to avoid premature line wear or engine drag.

- Cutting from left to right improves the unit's cutting efficiency. Clippings are thrown away from the operator.
- Slowly move the trimmer into and out of the cutting area at the desired height. Move either in a forward-backward or side-to-side motion. Cutting shorter lengths produces the best results.
- Trim only when grass and weeds are dry.
- The life of your cutting line is dependent upon proper adherence of explained trimming techniques, what vegetation is cut, and where vegetation is cut.

For example, the line will wear faster when trimming against a foundation wall as opposed to trimming around a tree.

DECORATIVE TRIMMING

Decorative trimming is accomplished by removing all vegetation around trees, posts, fences and more.

Rotate the whole unit so that the cutting attachment is at a 30° angle to the ground (Fig. 28).

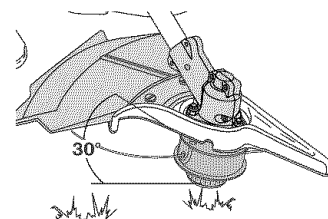
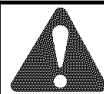
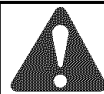

Fig. 28

USING THE CUTTING BLADE



WARNING: Always wear eye, hearing, foot, body protection and the shoulder strap to reduce the risk of injury when operating this unit.



WARNING: Do not use the cutting blade for edging or as an edger. Severe personal injury to yourself or others can result.

Before operating the unit with the cutting blade, stand in the operating position (Fig. 29). Refer to Holding the Trimmer.

Cutting Blade Operating Tips

To establish a rhythmic cutting procedure:

- Plant feet firmly, comfortably apart.
- Bring the engine to full throttle before entering the material to be cut. At full throttle the blade has maximum cutting power and is less likely to bind, stall or cause blade thrust (which can result in serious personal injury to the operator or others).
- Cut while swinging the upper part of your body from left to right.



WARNING: Blade thrust may occur when the spinning blade contacts an object that it does not immediately cut. Blade thrust can be violent enough to cause the unit and/or operator to be propelled in any direction, and possibly lose control of the unit. Blade thrust can occur without warning if the blade snags, stalls or binds. This is more likely to occur in areas where it is difficult to see the material being cut.

- Always release the throttle trigger and allow the engine to return to idle speed when not cutting.
- When you are finished, always unsnap the unit from the harness before taking off the harness.
- Swing the unit in the opposite direction as the blade spins, which increases the cutting action.

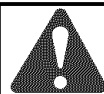

WARNING: The blade continues to spin after the engine is turned off. The coasting blade can seriously cut you if accidentally touched.

- After the return swing, move forward to the next area to be cut plant your feet again.
- The cutting blade is designed with a second cutting edge. You can use it by removing the blade, turning it upside down, and reinstalling it.

OPERATING INSTRUCTIONS

To reduce the chance of material wrapping around the blade, follow these steps:



WARNING: Do not sharpen the cutting blade. Sharpening the blade can cause the blade tip to break off while in use. This can result in severe personal injury to yourself or others. Replace the blade.

- Cut at full throttle
- Swing the unit into material to be cut from your left to your right (Fig. 30)
- Avoid the material just cut as you make the return swing



WARNING: Do not clear away any cut material with the engine running or blade turning. To avoid serious personal injury, turn off the engine. Allow the blade to stop before removing materials wrapped around the blade shaft.



Fig. 29

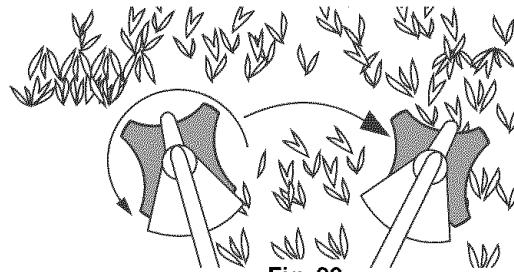

Fig. 30

MAINTENANCE AND REPAIR INSTRUCTIONS



WARNING: To prevent serious injury, never perform maintenance or repairs with unit running. Always service and repair a cool unit. Disconnect the spark plug wire to ensure that the unit cannot start.

MAINTENANCE SCHEDULE

Perform these required maintenance procedures at the frequency stated in the table. These procedures should also be a part of any seasonal tune-up.

NOTE: Some maintenance procedures may require special tools or skills. If you are unsure about these procedures take your unit to any non-road engine repair establishment, individual or authorized service dealer.

NOTE: Maintenance, replacement, or repair of the emission control devices and system may be performed by any non-road engine repair establishment, individual or authorized service dealer.

In order to assure peak performance of your engine, inspection of the engine exhaust port may be necessary after 50 hours of operation. If you notice lost RPM, poor performance or general lack of acceleration, this service may be required. If you feel your engine is in need of this inspection, refer service to any non-road engine repair establishment, individual or authorized service dealer for repair. **DO NOT** attempt to perform this process yourself as engine damage may result from contaminants involved in the cleaning process for the port.

FREQUENCY	MAINTENANCE REQUIRED	SEE
Before starting engine	Fill fuel tank with fresh fuel Check oil	p. 6 p. 12
Every 10 hours	Clean and re-oil air filter	p. 13
1 st change at 10 hours Change at 25 hours Every 25 hours	Change oil Change oil Clean spark arrestor	p. 12 p. 12 p. 16
10 hours on new engine	Check rocker arm to valve clearance and adjust	p. 14
Every 25 hours	Check rocker arm to valve clearance and adjust	p. 14
Every 25 hours	Check spark plug condition and gap	p. 15

MAINTENANCE AND REPAIR INSTRUCTIONS

LINE INSTALLATION

This section covers both SplitLine™ and standard single line installation.

Always use original equipment manufacturer 0.105 in. (2.67 mm) replacement line. Other types of line may make the engine overheat or fail.



WARNING: Never use metal-reinforced line, wire, chain or rope. These can break off and become dangerous projectiles.

There are two methods to replace the trimming line:

- Wind the inner reel with new line
- Install a prewound inner reel

Winding the Existing Inner Reel

1. Hold the outer spool with one hand and unscrew the Bump Knob clockwise (Fig. 31). Inspect the bolt inside the bump knob to make sure it moves freely. Replace the bump knob if damaged.
2. Remove the inner reel from the outer spool (Fig. 31).
3. Remove spring from the inner reel (Fig. 31).

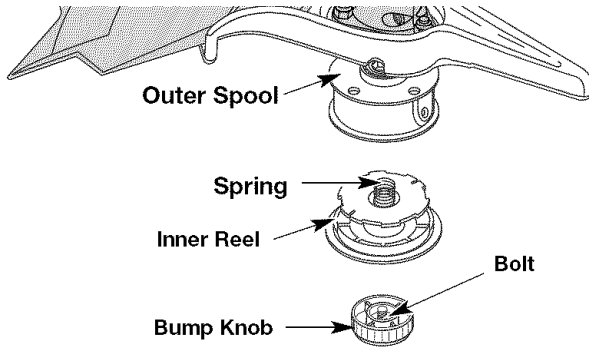

Fig. 31

4. Use a clean cloth to clean the the inner reel, spring, shaft and inner surface of the outer spool (Fig. 32).
5. Check the indexing teeth on the inner reel and outer spool for wear (Fig. 33). If necessary, remove burrs or replace the reel and spool.

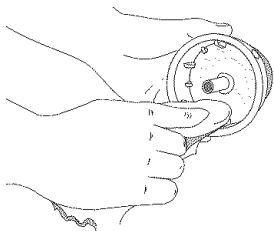

Fig. 32

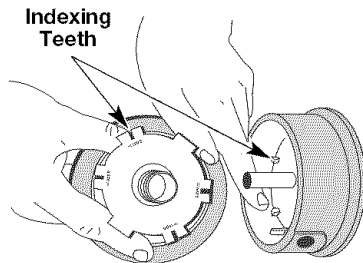

Fig. 33

For Use with Single
Line ONLY

For Use with SplitLine™ or
Single Line

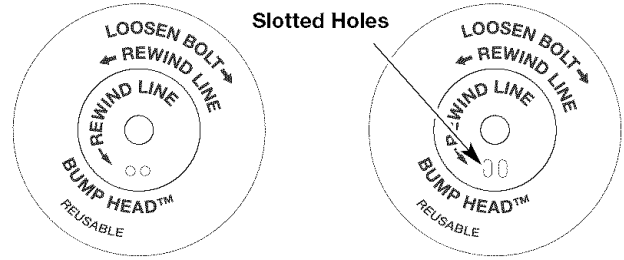

Fig. 34

NOTE: SplitLine™ can only be used with the inner reel with the slotted holes. Single line can be used on either type of inner reel. Use Figure 34 to identify the inner reel you have.

NOTE: Always use the correct line length when installing trimming line on the unit. The line may not release properly if the line is too long.

Single Line Installation

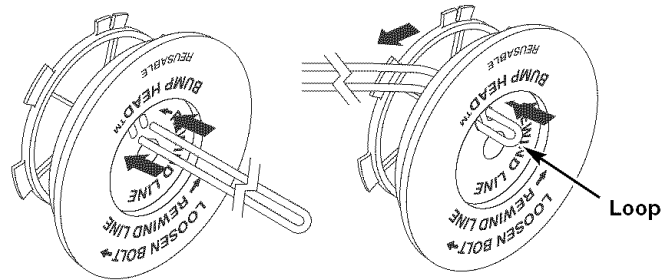

Fig. 35

Go To Step 8 for SplitLine™ Installation

6. Take approximately 18 feet (6 m) of new trimming line, loop it into two equal lengths. Insert each end of the line through one of the two holes in the inner reel (Fig. 35). Pull the line through the inner reel so that the loop is as small as possible.
7. Wind the lines in tight even layers, onto the reel (Fig. 36). Wind the line in the direction indicated on the inner reel. Place your index finger between the two lines to stop the lines from overlapping. Do not overlap the ends of the line. Proceed to step 11.

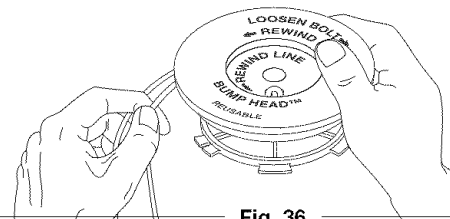

Fig. 36

SplitLine™ Installation

8. Take approximately 9 feet (3 m) of new trimming line. Insert one end of the line through one of the two holes in the inner reel (Fig. 37). Pull the line through the inner reel until only about 4 inches is left out.
9. Insert the end of the line into the open hole in the inner reel and pull the line tight to make the loop as small as possible (Fig. 37).

MAINTENANCE AND REPAIR INSTRUCTIONS

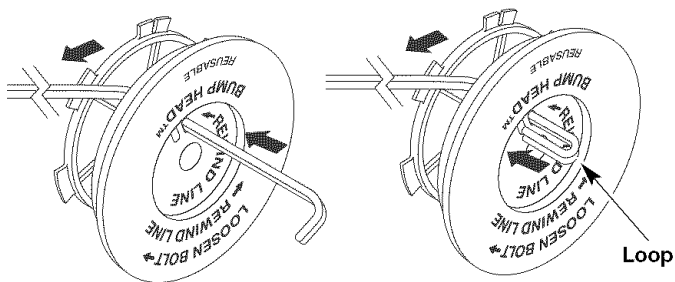

Fig. 37

10. Before winding, split the line back about 6 inches.
11. Wind the line in tight even layers in the direction indicated on the inner reel.

NOTE: Failure to wind the line in the direction indicated will cause the cutting attachment to operate incorrectly.

12. Insert the ends of the line into the two holding slots (Fig. 38).

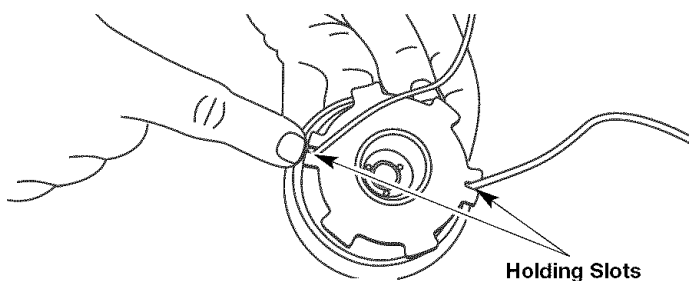

Fig. 38

13. Insert the ends of the line through the eyelets in the outer spool and place inner reel with spring inside the outer spool (Fig. 39). Push the inner reel and outer spool together. While holding the inner reel and outer spool, grasp the ends and pull firmly to release the line from the holding slots in the reel.

NOTE: The spring must be assembled on the inner reel before reassembling the cutting attachment.

14. Hold the inner reel in place and install the bump knob by turning counterclockwise. Tighten securely.

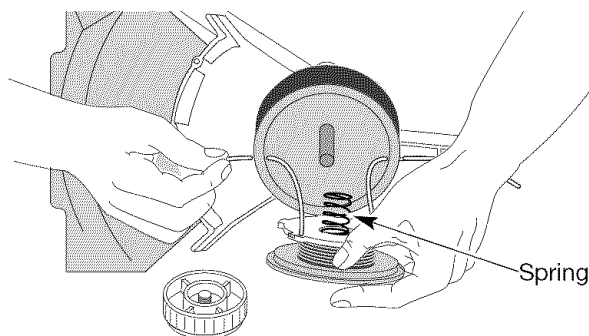

Fig. 39

INSTALLING A PREWOUND REEL

1. Hold the outer spool with one hand and unscrew the bump knob clockwise (Fig. 31). Inspect the bolt inside the bump knob to make sure it moves freely. Replace the bump knob if damaged.
2. Remove the old inner reel from the outer spool (Fig. 31).
3. Remove the spring from the old inner reel (Fig. 31).
4. Place the spring in the new inner reel.

NOTE: The spring must be assembled on the inner reel before reassembling the cutting attachment.

5. Insert the ends of the line through the eyelets in the outer spool (Fig. 39).
6. Place the new inner reel inside the outer spool. Push the inner reel and outer spool together. While holding the inner reel and outer spool, grasp the ends and pull firmly to release the line from the holding slots in the spool.
7. Hold the inner reel in place and install the bump knob by turning counterclockwise. Tighten securely.

CHECKING THE OIL LEVEL

The importance of checking and maintaining the proper oil level in the crankcase cannot be overemphasized. Check oil before each use:



CAUTION: To prevent extensive engine wear and damage to the unit, always maintain the proper oil level in the crankcase. Never operate the unit with the oil level below the bottom of the dipstick.

1. Stop the engine and allow oil to drain into the crankcase.
2. Place the engine on a flat, level surface with the cutting head shield hanging off a work bench or table to get a proper oil level reading (Fig. 40).

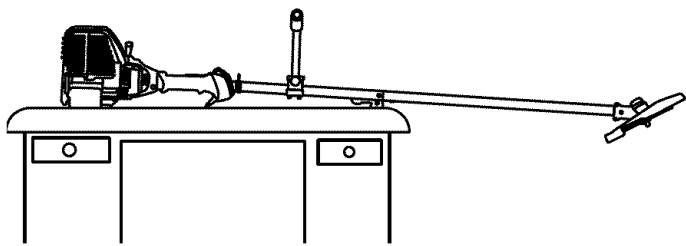

Fig. 40

3. Keep dirt, grass clippings and other debris out of the engine. Clean the area around the dipstick before removing it.
4. Remove the oil fill plug.
5. Look into the oil fill hole, use a flashlight if needed. The oil should be just touching the inner most thread (Fig. 41).
6. If the oil level is not touching the inner most thread on the oil fill hole, add a small amount of oil to the oil fill hole and recheck (Fig. 41). Repeat this procedure until the oil level reaches the inner most thread on the oil fill hole.

NOTE: Do not overfill the unit.

NOTE: Make sure the O-ring is in place on the oil fill plug when checking and changing the oil (Fig. 42).

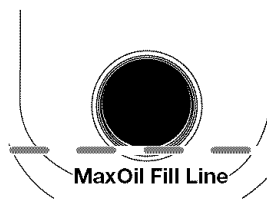

Fig. 41

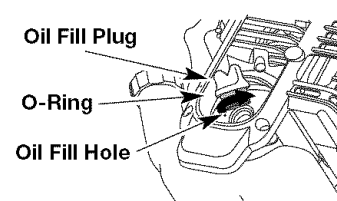

Fig. 42

MAINTENANCE AND REPAIR INSTRUCTIONS

CHANGING THE OIL

For a new engine, change the oil after the first 10 hours of operation. Change the oil while the engine is still warm. The oil will flow freely and carry away more impurities.

1. Unplug spark plug boot to prevent accidental starting.



WARNING: Wear gloves to prevent injury when handling unit.

2. Remove the oil fill plug.
3. Pour the oil out of the oil fill hole and into a container by tipping the unit to a vertical position (Fig. 43). Allow ample time for complete drainage.
4. Wipe up any oil residue on the unit and clean up any oil that may have spilled. Dispose of the oil according to Federal, State and local regulations.
5. Refill the crankcase with 3.04 fluid ounce (90 ml) of SAE 30 SF, SG, SH oil.

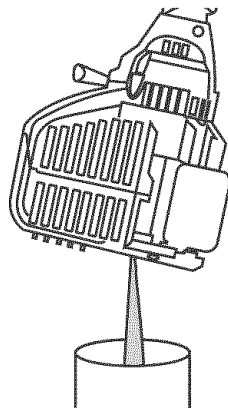

Fig. 43

NOTE: Use the bottle and spout saved from initial use to measure the correct amount of oil. The top of the label on the bottle measures approximately 3.04 ounces (90 ml) (Fig. 44). Check the level, See *Checking the Oil Level*. If the level is low, add a small amount of oil and recheck. Do not overfill (Fig. 44).

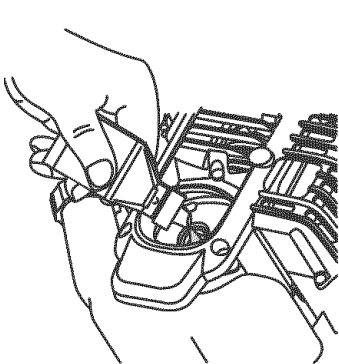
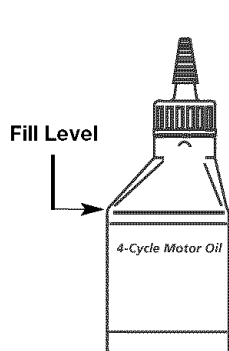

Fig. 44



6. Replace the oil fill plug.
7. Reconnect the spark plug boot.

AIR FILTER MAINTENANCE



WARNING: To avoid serious personal injury, always turn the unit off and allow it to cool before you clean or service it.

Cleaning the Air Filter

Clean and re-oil the air filter every 10 hours of operation. It is an important item to maintain. Failure to maintain your air filter properly can result in poor performance or can cause permanent damage to your engine.

1. Open the air filter cover. Push the tab on the under side of the cover inward. Then pull the air filter cover out and up. (Fig. 45).

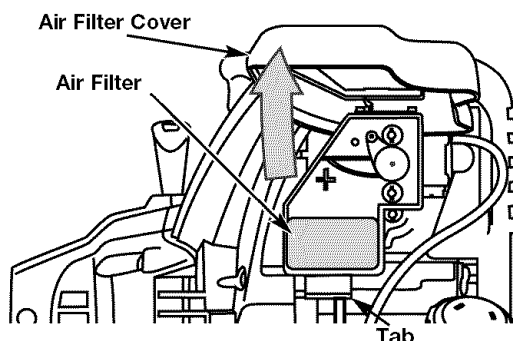

Fig. 45

2. Remove the air filter (Fig. 45).
3. Wash the filter in detergent and water (Fig. 46). Rinse the filter thoroughly and allow it to dry.
4. Apply enough clean SAE 30 motor oil to lightly coat the filter (Fig. 47).
5. Squeeze the filter to spread and remove excess oil (Fig. 48).
6. Replace the filter (Fig. 45).

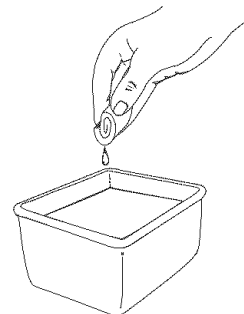

Fig. 46

NOTE: If the unit is operated without the air filter, you will **VOID** the warranty.

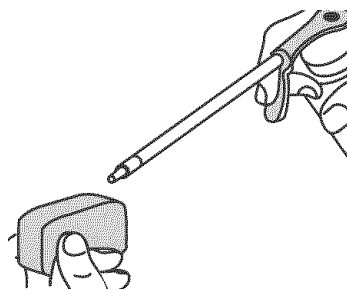

Fig. 47

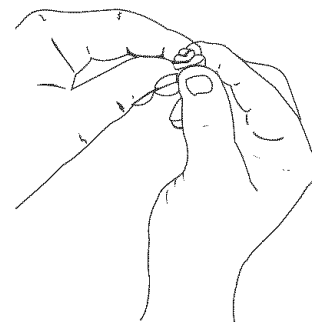

Fig. 48

7. Reinstall the air filter cover. Position the slots on the top of the air filter cover onto the tabs at the top of the back plate (Fig. 49).
8. Swing the cover down until the tab on the air filter backplate snaps into place in the slot on the air filter cover (Fig. 50).

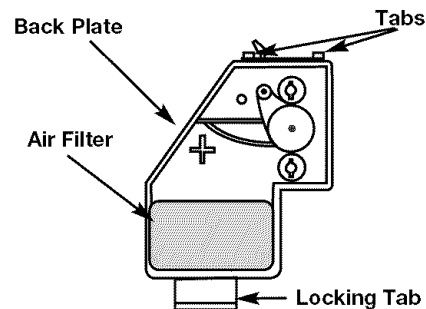

Fig. 49

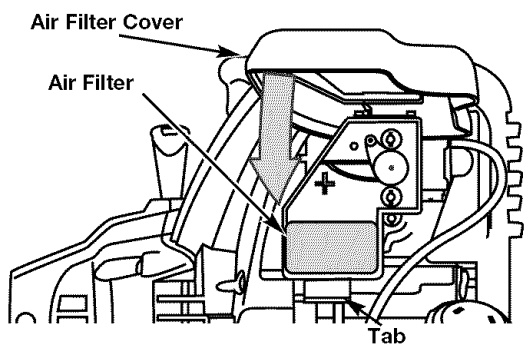

Fig. 50

CARBURETOR ADJUSTMENT

The idle speed of the engine is adjustable. An idle adjustment screw is between the air filter cover and the engine starter housing (Fig. 51).

NOTE: Careless adjustments can seriously damage your unit. An authorized service dealer should make carburetor adjustments.

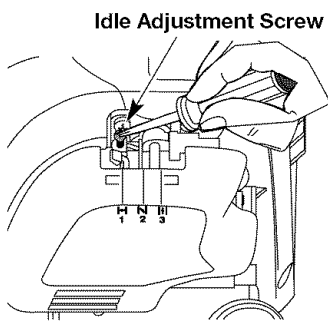

Fig. 51

Check Fuel

Old fuel is usually the reason for improper unit performance. Drain and refill the tank with fresh fuel prior to making any adjustments. Refer to *Oil and Fuel Information*.

Clean Air Filter

The condition of the air filter is important to the operation of the unit. A dirty air filter will restrict air flow. This is often mistaken for an out of adjustment carburetor. Check the condition of the air filter before adjusting the idle speed screw. Refer to *Air Filter Maintenance*.

Adjust Idle Speed Screw

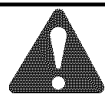

WARNING: To prevent serious personal injury, make sure the cutting attachment has stopped rotating before you turn it off and set it down.

If, after checking the fuel and cleaning the air filter, the engine still will not idle, adjust the idle speed screw as follows:

1. Start the engine and let it run at a high idle for a minute to warm up. Refer to *Starting/Stopping Instructions*.
2. Release the throttle trigger and let the engine idle. If the engine stops, insert a small phillips in between the Air Filter Cover and the Engine Cover (Fig. 51). Turn the idle speed screw in, **clockwise**, 1/8 of a turn at a time (as needed) until the engine idles smoothly.

NOTE: The cutting attachment should not rotate when the engine idles.

3. If the cutting attachment rotates when the engine idles, turn the idle speed screw **counterclockwise** 1/8 of a turn at a time (as needed), to reduce idle speed.



WARNING: The cutting attachment may spin during idle speed adjustments. Wear protective clothing and observe all safety instructions to prevent serious personal injury.

Checking the fuel, cleaning the air filter, and adjusting the idle speed should solve most engine problems. If not and all of the following are true:

- the engine will not idle
- the engine hesitates or stalls on acceleration
- there is a loss of engine power

Have the carburetor adjusted by an authorized service dealer.

ROCKER ARM CLEARANCE

This requires disassembly of the engine. If you feel unsure or unqualified to perform this, take the unit to an authorized service center.

NOTE: Inspect the valve to rocker arm clearance with a feeler gauge after the first 10 hours of operation and every 25 hours of operation.

- The engine must be cold when checking or adjusting the valve clearance.
 - This task should be performed inside, in a clean, dust free area.
1. Remove the six (6) screws on the back of the engine cover with a Flat-head or T-25 Torx screwdriver (Fig. 52).
 2. Disconnect the spark plug wire.
 3. Clean dirt from around the spark plug. Remove the spark plug from the cylinder head by turning a 5/8 in. socket counterclockwise.
 4. Remove the engine cover (Fig. 52).

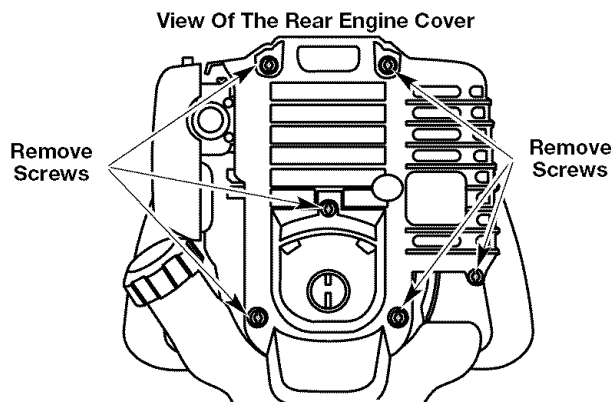

Fig. 52

5. Clean dirt from around the rocker arm cover. Remove the screw holding the rocker arm cover with a large flat blade screwdriver or Torx T-25 bit (Fig. 53). Remove the rocker arm cover and gasket.

6. Pull the starter rope slowly to bring the piston to the top of its travel, (known as top dead center). Check that:

- The piston is at the top of its travel while looking in the spark plug hole (Fig. 54)
- Both rocker arms move freely, and both valves are closed

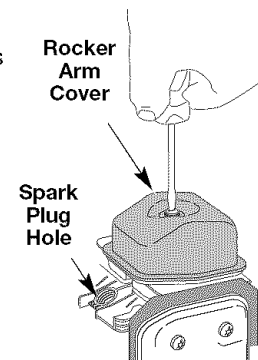

Fig. 53

MAINTENANCE AND REPAIR INSTRUCTIONS

If these statements are not true, repeat this step.

7. Slide the feeler gauge between the rocker arm and the valve return spring. Measure the clearance between the valve stem and rocker arm (Fig. 54). Measure both the intake and exhaust valves.

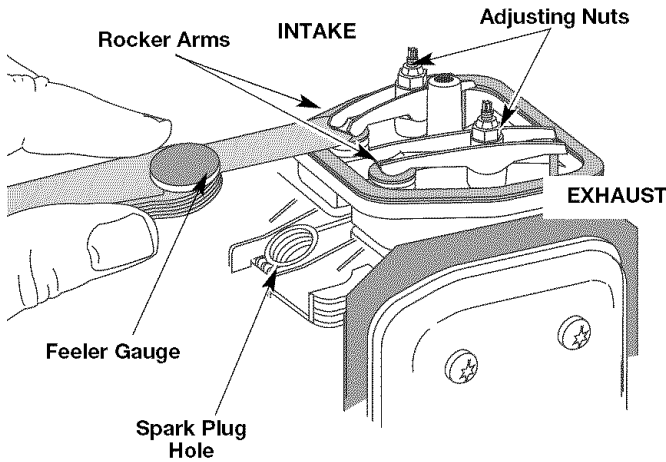

Fig. 54

The recommended clearance for both intake and exhaust is .003 – .006 in. (.076 – 0.152 mm). Use a standard automotive .005 in. (0.127 mm) feeler gauge. The feeler gauge should slide between the rocker arm and valve stem with a slight amount of resistance, without binding. See Figures 54 and 55.

8. If the clearance is not within specification:
 - a. Turn the adjusting nut using a 5/16 inch (8 mm) wrench or nut driver (Fig. 54).
 - To increase clearance, turn the adjusting nut counterclockwise.
 - To decrease clearance, turn the adjusting nut clockwise.
 - b. Recheck both clearances, and adjust as necessary.
9. Reinstall the rocker arm cover using a new gasket. Torque the screw to 20–30 in•lb (2.2–3.4 N•m).
10. Check the spark plug and reinstall. See *Replacing the Spark Plug*.
11. Replace the spark plug wire.
12. Reinstall the engine cover. Check alignment of the cover before tightening the screws. Tighten screws.

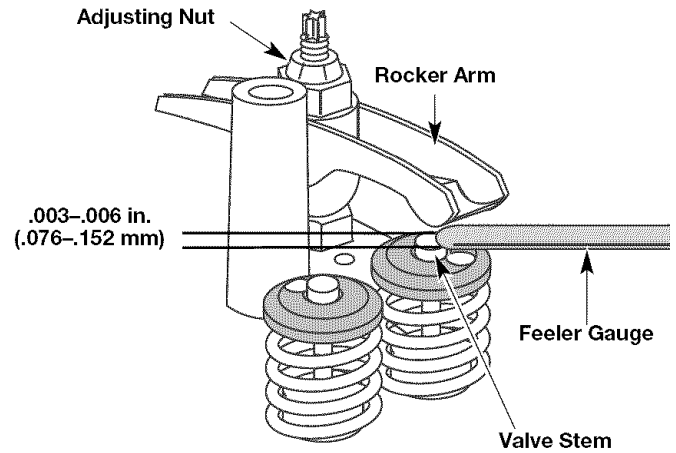

Fig. 55

REPLACING THE SPARK PLUG

Use a replacement part number 753-05255 spark plug. The correct air gap is 0.025 in. (0.655 mm.). Remove the plug after every 25 hours of operation and check its condition.

1. Stop the engine and allow it to cool. Remove the six (6) screws on the back of the engine cover with a Flat-head or T-25 Torx screwdriver (Fig. 52).
2. Grasp the plug wire firmly and pull the cap from the spark plug.
3. Clean dirt from around the spark plug. Remove the spark plug from the cylinder head by turning a 5/8 in. socket counterclockwise.
4. Replace cracked, fouled or dirty spark plug. Set the air gap at 0.025 in. (0.655 mm.) using a feeler gauge (Fig. 56).
5. Install a correctly-gapped spark plug in the cylinder head. Turn the 5/8 in. socket clockwise until snug.

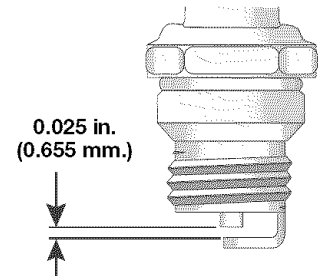

Fig. 56

If using a torque wrench torque to:
110-120 in.•lb. (12.3-13.5 N•m)

Do not over tighten.

	WARNING: Do not sand blast, scrape or clean electrodes. Grit in the engine could damage the cylinder.
--	--

SPARK ARRESTOR MAINTENANCE

1. Remove the rear engine cover. See *Rocker Arm Clearance*.
2. With a flat blade screwdriver or Torx T-20 bit and a T-25 bit, remove the screws attaching the spark arrestor cover to the muffler (Fig. 57).

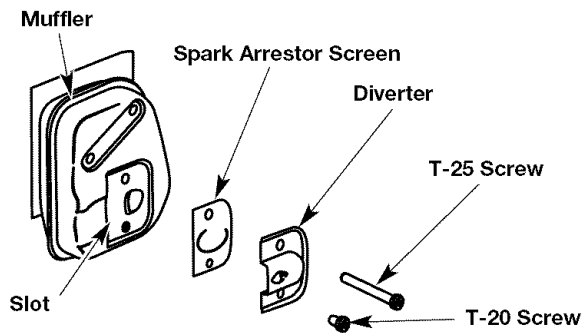

Fig. 57

3. Pull the tab on the spark arrestor cover out of the muffler. Remove the spark arrestor cover.
4. Remove the spark arrestor screen from the spark arrestor cover.
5. Clean the spark arrestor screen with a wire brush or replace it.
6. Reinstall the spark arrestor screen, spark arrestor cover and screws.

CLEANING



WARNING: To avoid serious personal injury, always turn your unit off and allow it to cool before you clean or service it.

Use a small brush to clean off the outside of the unit. Do not use strong detergents. Household cleaners that contain aromatic oils such as pine and lemon, and solvents such as kerosene, can damage plastic housing or handle. Wipe off any moisture with a soft cloth.

STORAGE

- Never store the unit with fuel in the tank where fumes may reach an open flame or spark.
- Allow the engine to cool before storing.
- Lock up the unit to prevent unauthorized use or damage.
- Store the unit in a dry, well-ventilated area.
- Store the unit out of the reach of children.

LONG TERM STORAGE

1. Drain all gasoline from the gas tank into a container. Do not use gas that has been stored for more than 60 days. Dispose of the old gasoline in accordance to Federal, State, and Local regulations.
2. Start the engine and allow it to run until it stalls. This ensures that all gasoline has been drained from the carburetor.
3. Allow the engine to cool. Remove the spark plug and put 1 oz. (30 ml) of high quality motor oil into the cylinder. Pull the starter rope slowly to distribute the oil. Reinstall the spark plug.

NOTE: Remove the spark plug and drain all of the oil from the cylinder before attempting to start the trimmer after storage.

4. Change the oil, referring to *Changing the Oil*. Dispose of the old oil in accordance to Federal, State and Local regulations.
5. Thoroughly clean the unit and inspect for any loose or damaged parts. Repair or replace damaged parts and tighten loose screws, nuts or bolts. The unit is ready for storage.

TRANSPORTING

- Allow the engine to cool before transporting.
- Secure the unit while transporting.
- Drain the gas tank before transporting.
- Tighten gas cap before transporting.

TROUBLESHOOTING

ENGINE WILL NOT START

CAUSE

On/Off control in the STOP position
 Empty fuel tank
 Primer bulb wasn't pressed enough
 Old fuel
 Fouled spark plug
 Plugged spark arrestor

ACTION

Turn On/Off control to ON
 Fill fuel tank with new fuel
 Press primer bulb fully and slowly 10 times
 Drain gas tank and add fresh fuel
 Replace or clean the spark plug
 Clean or replace spark arrestor

ENGINE WILL NOT IDLE

CAUSE

Air filter is plugged
 Old fuel
 Improper carburetor adjustment

ACTION

Replace or clean the air filter
 Drain gas tank and add fresh fuel
 Adjust carburetor

ENGINE WILL NOT ACCELERATE

CAUSE

Old fuel
 Improper carburetor adjustment
 Cutting attachment bound with grass
 Dirty air filter
 Plugged spark arrestor

ACTION

Drain gas tank and add fresh fuel
 Take to an authorized service dealer for adjustment
 Stop the engine and clean the cutting attachment
 Clean or replace the air filter
 Clean or replace spark arrestor

ENGINE LACKS POWER OR STALLS WHEN CUTTING

CAUSE

Old fuel
 Improper carburetor adjustment
 Fouled spark plug
 Plugged spark arrestor

ACTION

Drain gas tank and add fresh fuel
 Take to an authorized service dealer for adjustment
 Replace or clean the spark plug
 Clean or replace spark arrestor

CUTTING ATTACHMENT WILL NOT ADVANCE LINE

CAUSE

Cutting attachment bound with grass
 Cutting attachment out of line
 Inner reel bound up
 Cutting head dirty
 Line welded
 Line twisted when refilled
 Not enough line is exposed

ACTION

Stop the engine and clean cutting attachment
 Refill with new line
 Replace the inner reel
 Clean inner reel and outer spool
 Disassemble, remove the welded section and rewind
 Disassemble and rewind the line
 Push the bump knob and pull out line until 4 inches (102 mm) of line is outside of the cutting attachment

CUTTING LINE ADVANCES UNCONTROLLABLY

CAUSE

Oil, cleaner or lubricant in cutting head

ACTION

Clean and thoroughly dry the cutting head

If further assistance is required, contact your authorized service dealer.

SPECIFICATIONS

ENGINE*

Engine Type.....	Air-Cooled, 4-Cycle
Displacement.....	1.8 cu. in. (29 cc)
Operating RPM.....	6,800+ rpm
Idle Speed RPM.....	2,800 - 3,600 rpm
Ignition Type.....	Electronic
Ignition Switch.....	Rocker Switch
Valve clearance.....	0.003–0.006 in. (0.076–0.152 mm)
Spark Plug Gap.....	0.025 inch (0.655 mm)
Lubrication.....	SAE 30 Oil
Crankcase Oil Capacity.....	3.04 oz (90 ml)
Fuel.....	Unleaded
Carburetor.....	Diaphragm, All-Position
Starter.....	Auto Rewind
Muffler.....	Baffled with Guard
Throttle.....	Manual Spring Return
Fuel Tank Capacity.....	14 oz (414 ml)

DRIVE SHAFT AND CUTTING ATTACHMENT*

Drive Shaft Housing.....	Steel Tube (EZ-Link™)
Throttle Control.....	Finger-Tip Trigger
Approximate Unit Weight (No fuel, with handle, cutting attachment and shield).....	12-13.5 lbs (5.4-6 kg)
Cutting Mechanism.....	4-Tooth Cutting Blade, Dual String Cutting Head
Line Spool.....	Bump Line Releaser
Line Spool Diameter.....	4 inches (101.6 mm)
Trimming Line Diameter.....	0.105 inches (2.67 mm)
Cutting Path Diameter, Trimmer Head.....	18 inches (45.7 cm)
Cutting Path Diameter, Blade Head.....	8 inches (204 mm)
Shoulder Harness.....	Single Quick-Snap

*All specifications are based on the latest product information available at the time of printing. We reserve the right to make changes at any time without notice.

California / EPA Emission Control Warranty Statement

Your Warranty Rights and Obligations

The California Air Resources Board, the Environmental Protection Agency and MTD LLC (MTD) are pleased to explain the emission control system warranty on your 2005 and later small off-road engine. New small off-road engines must be designed, built and equipped to meet stringent anti-smog standards. MTD must warrant the emission control system on your small off-road engine for the periods of time listed below provided there has been no abuse, neglect or improper maintenance of your small off-road engine.

Your emission control system may include parts such as the carburetor or fuel-injected system, the ignition system, and catalytic converter. Also included may be hoses, belts, connectors and other emission-related assemblies.

Where a warrantable condition exists, Troy-Bilt will repair your small off-road engine at no cost to you including diagnosis, parts and labor.

The 2005 and later small off-road engines are warranted for two years. If any emission-related part on your engine is defective, the part will be repaired or replaced by Troy-Bilt.

Owners Warranty Responsibilities

- As the small off-road engine owner, you are responsible for the performance of the required maintenance listed in your operator's manual. Troy-Bilt recommends that you retain all receipts covering maintenance on your small off-road engine, but Troy-Bilt cannot deny warranty solely for the lack of receipts or for your failure to ensure the performance of all scheduled maintenance.
- As the small off-road engine owner, you however should be aware that Troy-Bilt may deny you warranty coverage if your small off-road engine or a part has failed due to abuse, neglect, improper maintenance or unapproved modifications.
- You are responsible for presenting your small off-road engine to a Troy-Bilt Authorized Service Center as soon as a problem exists. The warranty repairs should be completed in a reasonable amount of time, not to exceed 30 days.

If you have any questions regarding your warranty rights and responsibilities, you should call 1-800-520-5520.

Manufacturer's Warranty Coverage

- The warranty period begins on the date the engine or equipment is delivered to the retail purchaser.
- The manufacturer warrants to the initial owner and each subsequent purchaser, that the engine is free from defects in material and workmanship which cause the failure of a warranted part for a period of two years.
- Repair or replacement of warranted part will be performed at no charge to the owner at an Authorized Troy-Bilt Service Center. For the nearest location please contact Troy-Bilt at: 1-800-520-5520.
- Any warranted part which is not scheduled for replacement, as required maintenance or which is scheduled for only for regular inspection to the effect of "Repair or Replace as Necessary" is warranted for the warranty period. Any warranted part which is scheduled for replacement as required maintenance will be warranted for the period of time up to the first scheduled replacement point for that part.
- The owner will not be charged for diagnostic labor which leads to the determination that a warranted part is defective, if the diagnostic work is performed at an Authorized Troy-Bilt Service Center.
- The manufacturer is liable for damages to other engine components caused by the failure of a warranted part still under warranty.
- Failures caused by abuse, neglect or improper maintenance are not covered under warranty.
- The use of add-on or modified parts can be grounds for disallowing a warranty claim. The manufacturer is not liable to cover failures of warranted parts caused by the use of add-on or modified parts.
- In order to file a claim, go to your nearest Authorized Troy-Bilt Service Center. Warranty services or repairs will be provided at all Authorized Troy-Bilt Service Centers.
- Any manufacturer approved replacement part may be used in the performance of any warranty maintenance or repair of emission related parts and will be provided without charge to the owner. Any replacement part that is equivalent in performance or durability may be used in non-warranty maintenance or repair and will not reduce the warranty obligations of the manufacturer
- The following components are included in the emission related warranty of the engine, air filter, carburetor, primer, fuel lines, fuel pick up/ fuel filter, ignition module, spark plug and muffler.

MANUFACTURER'S LIMITED WARRANTY FOR:



The limited warranty set forth below is given by Troy-Bilt LLC with respect to new merchandise purchased and used in the United States, its possessions and territories.

Troy-Bilt LLC warrants this product against defects in material and workmanship for a period of two (2) years commencing on the date of original purchase and will, at its option, repair or replace, free of charge, any part found to be defective in material or workmanship. This limited warranty shall only apply if this product has been operated and maintained in accordance with the Operator's Manual furnished with the product, and has not been subject to misuse, abuse, commercial use, neglect, accident, improper maintenance, alteration, vandalism, theft, fire, water or damage because of other peril or natural disaster. Damage resulting from the installation or use of any accessory or attachment not approved by Troy-Bilt LLC for use with the product(s) covered by this manual will void your warranty as to any resulting damage. This warranty is limited to ninety (90) days from the date of original retail purchase for any Troy-Bilt product that is used for rental or commercial purposes, or any other income-producing purpose.

HOW TO OBTAIN SERVICE: Warranty service is available, WITH PROOF OF PURCHASE THROUGH YOUR LOCAL AUTHORIZED SERVICE DEALER. To locate the dealer in your area, visit our website at www.troybilt.com, check for a listing in the Yellow Pages, call **1-800-520-5520** or write to P.O. Box 361131, Cleveland, OH 44136-0019.

This limited warranty does not provide coverage in the following cases:

- A. Tune-ups - Spark Plugs, Carburetor Adjustments, Filters
- B. Wear items - Bump Knobs, Outer Spools, Cutting Line, Inner Reels, Starter Pulley, Starter Ropes, Drive Belts
- C. Troy-Bilt LLC does not extend any warranty for products sold or exported outside of the United States of America, its possessions and territories, except those sold through Troy-Bilt's authorized channels of export distribution.

Troy-Bilt LLC reserves the right to change or improve the design of any Troy-Bilt Product without assuming any obligation to modify any product previously manufactured.

No implied warranty, including any implied warranty of merchantability or fitness for a particular purpose, applies after the applicable period of express written warranty above as to the parts as identified. No other express warranty or guaranty, whether written or oral, except as mentioned above, given by any person or entity, including a dealer or retailer, with respect to any product shall bind Troy-Bilt LLC. During the period of the Warranty, the exclusive remedy is repair or replacement of the product as set forth above. (Some states do not allow limitations on how long an implied warranty lasts, so the above limitation may not apply to you.)

The provisions as set forth in this Warranty provide the sole and exclusive remedy arising from the sales. Troy-Bilt LLC shall not be liable for incidental or consequential loss or damages including, without limitation, expenses incurred for substitute or replacement lawn care services, for transportation or for related expenses, or for rental expenses to temporarily replace a warranted product. (Some states do not allow limitations on how long an implied warranty lasts, so the above limitation may not apply to you.)

In no event shall recovery of any kind be greater than the amount of the purchase price of the product sold. Alteration of the safety features of the product shall void this Warranty. You assume the risk and liability for loss, damage, or injury to you and your property and/or to others and their property arising out of the use or misuse or inability to use the product.

This limited warranty shall not extend to anyone other than the original purchaser, original lessee or the person for whom it was purchased as a gift.

How State Law Relates to this Warranty: This warranty gives you specific legal rights, and you may also have other rights which vary from state to state.

To locate your nearest service dealer dial **1-800-520-5520**.

Troy-Bilt LLC

P.O. Box 361131

Cleveland, OH 44136-0019

PARTS LIST

REPLACEMENT PARTS - MODELS TB590BC
4-CYCLE GAS TRIMMER/BRUSHCUTTER

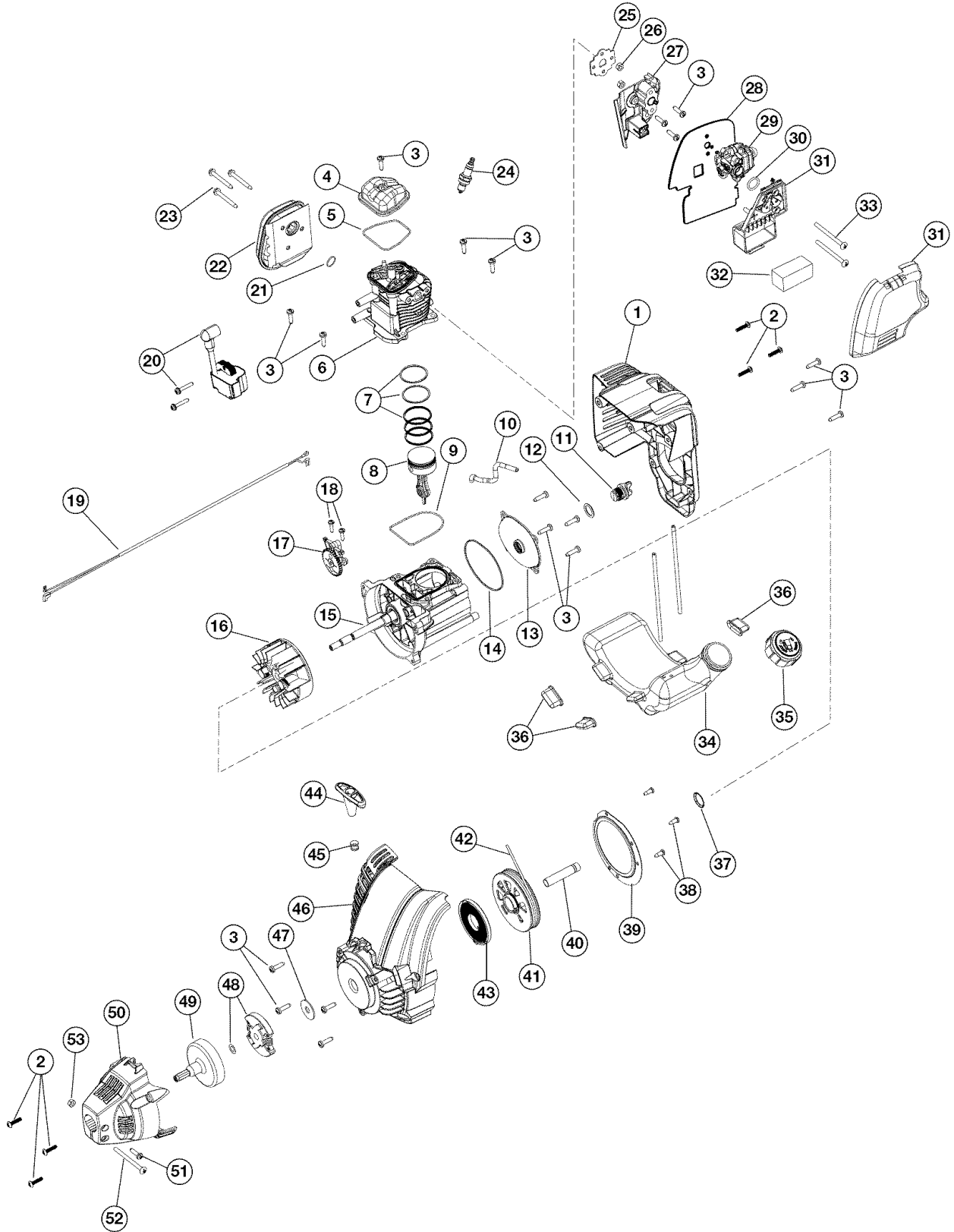

PARTS LIST

**REPLACEMENT PARTS - MODELS TB590BC
4-CYCLE GAS TRIMMER/BRUSHCUTTER**

<u>Item</u>	<u>Part No.</u>	<u>Description</u>	<u>Item</u>	<u>Part No.</u>	<u>Description</u>
1	753-05206	Engine Cover Assembly (includes 2 & 3)	30	791-181751	O-Ring
2	753-04595	Cover Screw	31	753-05252	Air Cleaner Cover Assembly (includes 32)
3	753-05208	Screw	32	753-05254	Air Filter
4	753-05209	Rocker Cover	33	753-05253	Screw
5	753-05210	Rocker Cover O-Ring	34	753-05256	Fuel Tank Assembly w/Fuel Lines (includes 35)
6	753-05228	Cylinder Assembly (includes 3, 5 & 9)	35	753-1229	Fuel Cap
7	753-05229	Piston Ring Assembly	36	753-05259	Fuel Tank Pads
8	753-05230	Piston Assembly (includes 7)	37	753-05260	Push Nut
9	753-05232	Cylinder O-Ring	38	753-1202	Pressure Plate Screw
10	791-182379	Breather Hose	39	753-05074	Pressure Plate (includes 38)
11	753-05236	Oil Plug (includes 12)	40	753-05078	Spacer
12	791-182290	Oil Plug O-Ring	41	753-05261	Starter Assembly (includes 42)
13	753-05237	Crankcase Cover	42	791-613103	Rope
14	753-05238	Crankcase Cover O-ring	43	753-04286	Recoil Spring
15	753-05239	Crankcase Assembly (includes 9, 10 & 14)	44	791-181079	Handle
16	753-05240	Flywheel Assembly	45	791-611061	Rope Guide
17	753-05241	Cam Bracket Assembly (includes 18)	46	753-05262	Starter Housing Assembly (includes 3 & 37-45)
18	753-05242	Cam Bracket Screw	47	791-182396	Washer
19	753-05264	Lead Wires	48	753-1238	Clutch & Clutch Washer
20	753-05243	Module Assembly	49	791-153592	Clutch Drum
21	753-05244	Muffler Gasket	50	753-05263	Clutch Cover
22	753-05245	Muffler Assembly (includes 21 & 23)	51	791-182519	Anti-Rotation Screw
23	753-05246	Muffler Screw	52	753-04003	Clamp Screw
24	753-05255	Spark Plug	53	791-180217	Nut
25	753-05247	Insulator Gasket	*	753-05297	Spark Arrestor Assembly
26	753-05248	Nut	*	753-05265	Shortblock Assembly (includes 3-12, 14, 15, 17 & 24)
27	753-05249	Insulator			
28	753-05250	Carburetor Gasket			
29	753-05251	Carburetor w/Primer			

PARTS LIST

**REPLACEMENT PARTS - MODELS TB590BC
4-CYCLE GAS TRIMMER/BUSHCUTTER**

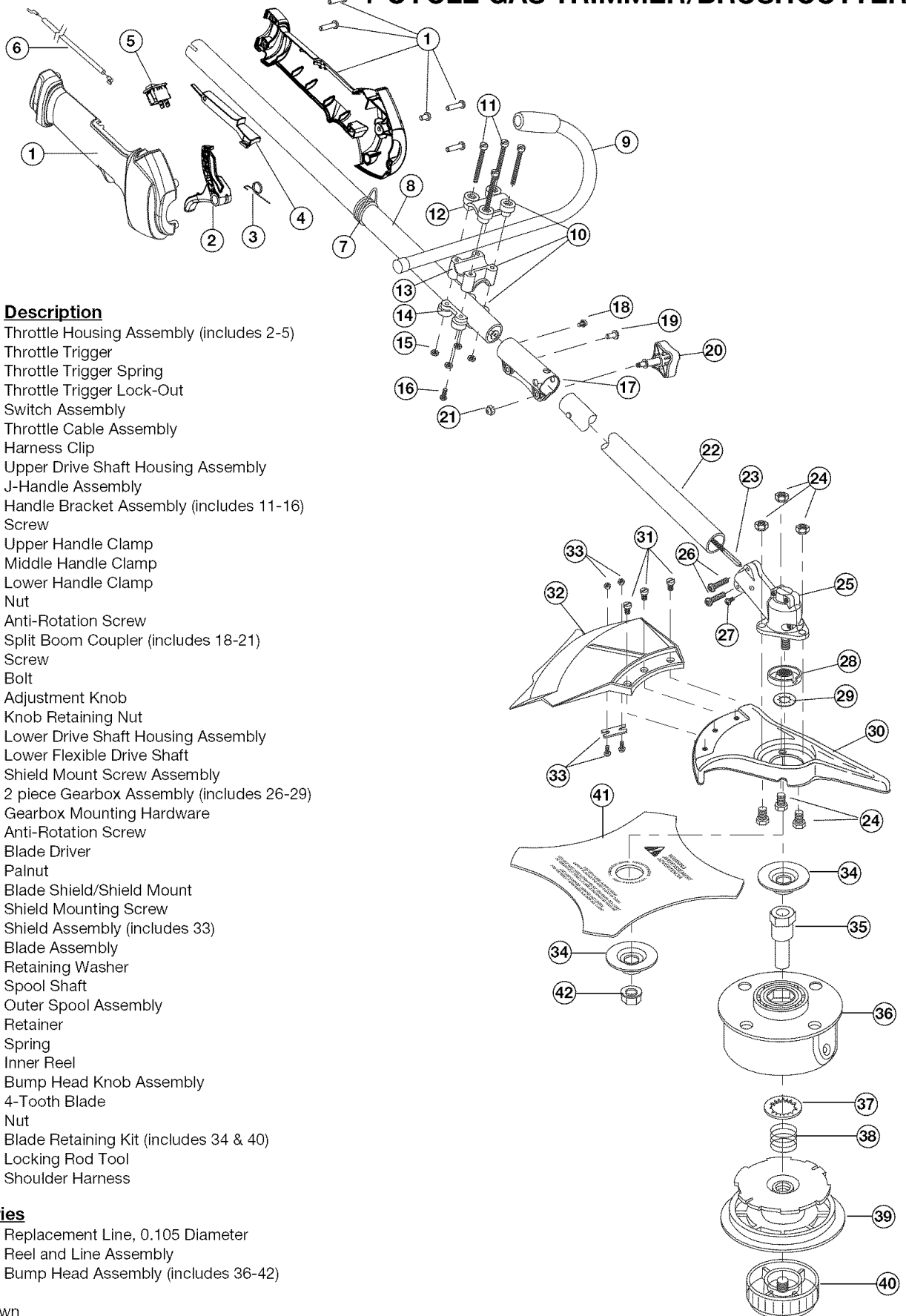

Item	Part No.	Description
1	753-05192	Throttle Housing Assembly (includes 2-5)
2	753-04991	Throttle Trigger
3	753-05007	Throttle Trigger Spring
4	753-05171	Throttle Trigger Lock-Out
5	791-182405	Switch Assembly
6	753-05270	Throttle Cable Assembly
7	791-610327	Harness Clip
8	753-04236	Upper Drive Shaft Housing Assembly
9	791-181099	J-Handle Assembly
10	791-683295	Handle Bracket Assembly (includes 11-16)
11	791-181811	Screw
12	791-181812	Upper Handle Clamp
13	791-181813	Middle Handle Clamp
14	791-181814	Lower Handle Clamp
15	791-181815	Nut
16	791-145569	Anti-Rotation Screw
17	753-1190	Split Boom Coupler (includes 18-21)
18	791-182057	Screw
19	791-181617	Bolt
20	791-181981	Adjustment Knob
21	753-04386	Knob Retaining Nut
22	753-04504	Lower Drive Shaft Housing Assembly
23	791-181570	Lower Flexible Drive Shaft
24	791-182200	Shield Mount Screw Assembly
25	791-182193	2 piece Gearbox Assembly (includes 26-29)
26	791-182195	Gearbox Mounting Hardware
27	791-145569	Anti-Rotation Screw
28	791-182196	Blade Driver
29	753-04348	Palnut
30	791-147492	Blade Shield/Shield Mount
31	791-683304	Shield Mounting Screw
32	753-1191	Shield Assembly (includes 33)
33	791-682061	Blade Assembly
34	791-147490	Retaining Washer
35	791-612483	Spool Shaft
36	791-683301	Outer Spool Assembly
37	791-612026	Retainer
38	791-610636B	Spring
39	791-147495	Inner Reel
40	791-180814B	Bump Head Knob Assembly
41	791-145873B	4-Tooth Blade
42	791-181699	Nut
*	791-180014B	Blade Retaining Kit (includes 34 & 40)
*	791-613226	Locking Rod Tool
*	791-682075B	Shoulder Harness

Optional Accessories

- * 753-04216 Replacement Line, 0.105 Diameter
- * 753-1224 Reel and Line Assembly
- * 753-1161 Bump Head Assembly (includes 36-42)

* Items Not Shown