

Use & Care Guide

Dishwasher

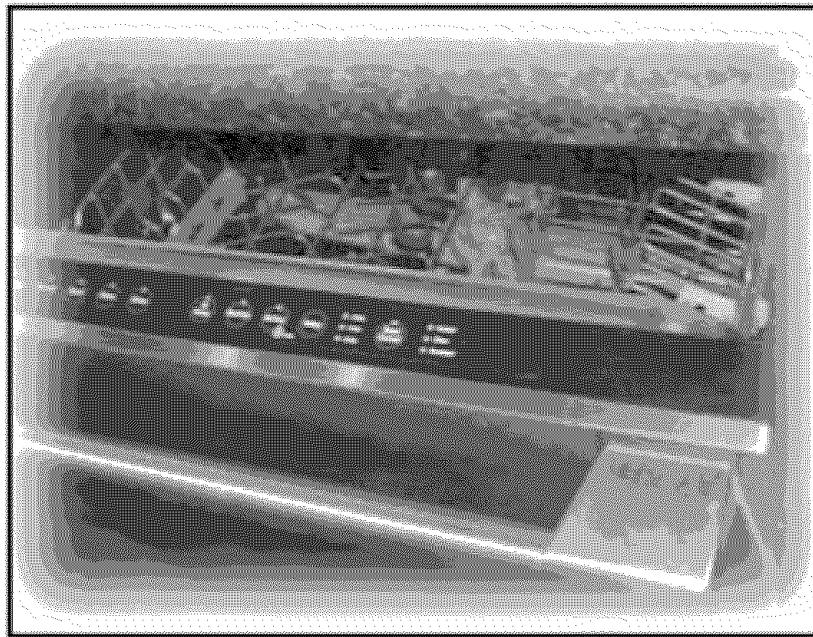

 **Electrolux**

2 Finding Information

PLEASE READ AND SAVE THIS GUIDE



Thank you for choosing **Electrolux**, the new premium brand in home appliances. This *Use & Care Guide* is part of our commitment to customer satisfaction and product quality throughout the service life of your new dishwasher.

We view your purchase as the beginning of a relationship. To ensure our ability to continue serving you, please use this page to record key product information.

IMPORTANT

PLEASE READ all instructions completely before attempting to install or operate the unit.

Once you have your unit installed, we suggest you keep this guide in a safe place for future reference. Should any problems occur, refer to the **Troubleshooting** section of this guide. This information will help you quickly identify a problem and get it remedied. In the event you require assistance, please contact the dealer where you purchased your unit.

MAKE A RECORD FOR QUICK REFERENCE



Whenever you call to request information or service, you will need to know your model number and serial number. You can find this information on the serial plate located on the inside wall of your unit and on the product registration card.

Attach your sales receipt to this page for future reference.

PRODUCT REGISTRATION CARD

The package containing this guide also includes your product registration information. Warranty coverage begins at the time your Electrolux dishwasher was purchased.

If you received a damaged product, immediately contact your dealer or builder. Do not install or use a damaged appliance.

NOTE

Registering your product with Electrolux enhances our ability to serve you. You can register online (at the Internet address below) or by dropping your Product Registration Card in the mail. Complete and mail the Product Registration Card as soon as possible to validate the registration date.

Please record the purchase date of your Electrolux unit and your dealer's name, address and telephone number.

Purchase Date

Electrolux Model Number

Electrolux Serial Number

Dealer Name

Dealer Address

Dealer Telephone

Keep this guide and the sales receipt together in a safe place for further reference.

QUESTIONS?

For toll-free telephone support in the U.S. and Canada:

1-877- 4ELECTROLUX (1-877-435-3287)

For online support and Internet product information in the U.S. visit **www.electroluxusa.com**. In Canada, visit **www.electroluxca.com**.

TABLE OF CONTENTS

Finding Information.....	2	Dishwasher Use.....	15
Please Read And Save This Guide	2	Hot Water.....	15
Make A Record For Quick Reference	2	Detergent	15
Product Registration Card	3	Rinse Aid.....	16
Questions?.....	3	Cycles, Options and Lights	17
Table Of Contents	4	Cycles	17
Safety.....	5	Options	18
Important Safety Instructions	5	Delay.....	19
General Precautions	6	Child Lock Option	20
What Can and Cannot Be Washed	7	Lights/Display	20
Operation.....	8	Care and Cleaning.....	21
Before You Start.....	8	General Recommendations	21
Operating the Dishwasher	8	Outside	21
Adding a Forgotten Item	9	Storage/Moving.....	22
Loading.....	10	Troubleshooting	23
General Recommendations	10	Warranty Information	27
10 Place Setting Load.....	10		
12 Place Setting Load.....	10		
Upper Rack.....	11		
Lower Rack.....	12		
Loading the Silver Basket	13		
Adjustable Upper Rack	14		
Removing the Upper Rack.....	14		

IMPORTANT SAFETY INSTRUCTIONS

Safety Precautions

Do not attempt to install or operate your unit until you have read the safety precautions in this guide. Safety items throughout this guide are labeled with a Warning or Caution based on the risk type.

Definitions

 This is the safety alert symbol. It is used to alert you to potential personal injury hazards. Obey all safety messages that follow this symbol to avoid possible injury or death.

WARNING

WARNING indicates a potentially hazardous situation which, if not avoided, could result in death or serious injury.

CAUTION

CAUTION indicates a potentially hazardous situation which, if not avoided, may result in minor or moderate injury.

CAUTION

CAUTION used without the safety alert symbol indicates a potentially hazardous situation which, if not avoided, may result in property damage.

IMPORTANT

Indicates installation, operation or maintenance information which is important but not hazard related.

6 Safety

General Precautions

WARNING

When using your dishwasher, follow basic precautions, including the following:

- Read all instructions before using the dishwasher.
- Use the dishwasher only for its intended function.
- Disconnect electrical power to dishwasher before attempting to service.
- To avoid electrical shock hazard, the sides and back must be enclosed and the front panels must be attached before electrical power is applied to the dishwasher. Refer to the installation instructions for proper grounding procedures.
- Connect to a properly rated, protected and sized power supply circuit to avoid electrical overload.
- Children should **never** be permitted to operate, or play in, with, or around this dishwasher.
- To reduce the risk of injury when loading items to be washed, sharp or pointed items should be located with the handles up. Also, load sharp items so they are not likely to damage the door seal.
- **Do not** touch the heating element on the bottom of the tub during or at the completion of a cycle. It will be hot.
- Use only detergents and rinse additives designed for a residential automatic dishwasher. **Never** use soap, laundry detergent, or hand washing detergent in your dishwasher. Keep these products out of reach of children.
- **Do not** sit, stand on or abuse the door or dish racks of the dishwasher.
- Under certain conditions, hydrogen gas may be produced in a hot water system that has not been used for two weeks or more. **Hydrogen gas is explosive.** If the hot water system has not been used for such a period, turn on all hot water faucets and let the water flow from each for several minutes. This will release any accumulated hydrogen gas. As the gas is flammable, **do not** smoke or use an open flame during this process.
- **Do not** wash plastic items unless marked "dishwasher safe" or the equivalent. For plastic items not so marked, check the manufacturer's recommendations.
- **Do not** tamper with controls.
- To prevent accidental child entrapment and suffocation risks, always remove the door to the washing compartment when removing an old dishwasher from service or discarding it.
- Use caution when unloading the dishwasher. Dishes will be hot if unloaded shortly after a cycle has completed.
- Certified residential dishwashers are **not** intended for licensed food establishments.
- To avoid water, mold or mildew damage to your home, inlet and drain hose connections should be checked periodically for leaks.

Save These Instructions for Future Reference

What Can & Cannot Be Washed

Most tableware, cookware and flatware can safely be washed in your dishwasher. Check with the manufacturer.

Material	Dishwasher Safe	Special Information
Aluminum	Yes, except anodized.	High water temperature and detergents may affect finish.
Cast Iron	No	Seasoning will be removed, and iron will rust.
China/Stoneware	Yes, except antique or hand-painted.	Always check manufacturer's recommendation before washing. Antique, hand-painted or over-the-glaze patterns may fade. Gold leaf may discolor.
Crystal	Yes, except antique or delicate crystal.	Always check manufacturer's recommendation before washing. Some types of leaded crystal may etch with repeated washings.
Filters	Not recommended.	May leave a dingy deposit or stain on dishwasher interior.
Glass	Yes	A specialty glass called "milk glass" can yellow with repeated dishwasher washing.
Gold-Plated Flatware	No	Will discolor.
Pewter, Tin	No	
Plastics	Yes, top rack, except disposable plastic items.	Always check manufacturer's recommendation before washing. Plastics vary in their capacity to withstand high water temperatures and detergents. Disposable plastic items are not dishwasher safe for this reason.
Stainless Steel	Yes	Run a Rinse cycle if not washing immediately. Prolonged contact with foods containing salt, vinegar, milk products or juice could damage finish.
Sterling Silver or Silverplate	No, if has commercial "darkening".	Always check manufacturer's recommendation before washing. Run a Rinse cycle if not washing immediately. Prolonged contact with food containing salt, acid or sulfide (eggs, mayonnaise and seafood) could damage finish. Commercial "darkening" may be removed by detergent.
Wooden Items	No	Wood may warp, crack or discolor.

8 Operation

BEFORE YOU START

- Prerinse is not required. Simply scrape off any bones or large food particles.
- If connected to a food waste disposer, **make certain the disposer is empty before starting the dishwasher.**
- **Scrape off tomato-based food soils** (see page 21).
- **Remove certain foods** such as mustard, mayonnaise, lemon juice, vinegar, salt or dressings **from stainless steel flatware as soon as possible.** These foods may cause rusting and pitting if allowed to remain in contact with the surface for an extended period of time.

OPERATING THE DISHWASHER

1. After loading the dishwasher and adding detergent, select the desired cycle and options by pressing the pads. The indicator lights for the selected cycle and options will illuminate. To cancel an option press the pad again.
2. To start a cycle, press the **START/Cancel** pad once then close the door until it latches. After a pause, the fill will begin.

IMPORTANT

- If **START/Cancel** is not pressed within 30 seconds of choosing your cycle, the dishwasher will turn off.

The dishwasher remembers your last cycle so you do not have to reset the cycle each time. To start the dishwasher using the same cycle and options selected on the previous wash, just press the **START/Cancel** pad.

3. To cancel a running cycle, press the **START/Cancel** pad once. The dishwasher will drain, then shut off. To turn the dishwasher off without draining, press the **START/Cancel** pad twice. To prevent unplanned cycle or option changes, these selections are “locked in” after 1 minute.

IMPORTANT

- If a cycle pad is pressed after the controls have been “locked in,” the light above the current cycle will flash three times.
-

ADDING A FORGOTTEN ITEM



For best cleaning, the forgotten item should be added early in the cycle.

1. Grasp door handle and unlatch door without opening completely.
2. Wait for the water circulation to stop.
3. Open the door and add the item.
4. Close and latch the door. After a slight delay, the cycle resumes automatically at the point of interruption.

IMPORTANT

- If the door is opened during a running cycle, there may be up to a 30-second delay before the dishwasher restarts after closing the door.
 - Extended interruption of the wash cycle is not recommended.
-

10 Loading

GENERAL RECOMMENDATIONS

- Items can be centered behind a single tine or loaded at an angle to maximize space.
- Avoid blocking or preventing the spray arms from spinning freely. Do not allow items to extend beyond the racks.
- Face soiled surfaces toward the center of the dishwasher.

For best dishwashing results follow guidelines on following pages to determine the best arrangement for your items.

10 PLACE SETTING LOAD

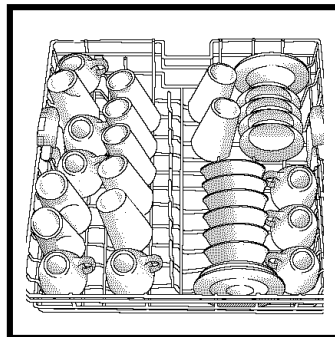

Upper Rack

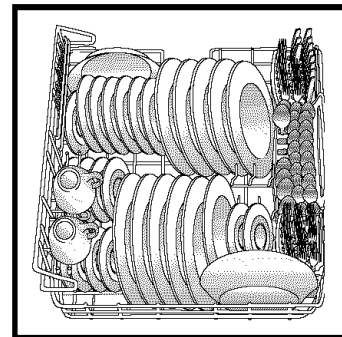

Lower Rack

12 PLACE SETTING LOAD

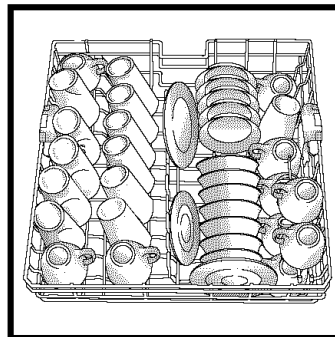

Upper Rack

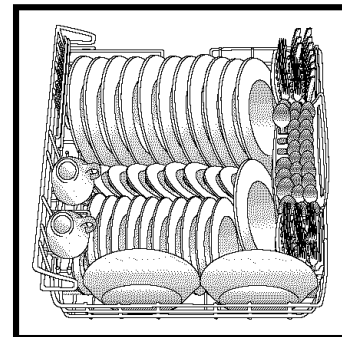

Lower Rack

UPPER RACK



Glasses, cups, stemware, light-weight plastics, plates, bowls, pans, long-handled utensils etc. can be loaded in this rack. **Do not load glasses over the tines.**

The Cup Shelf on the right side of the upper rack folds up or down for loading flexibility. Fold it down to hold long-handled knives, spatulas and spoons or short items like cups or juice glasses. Fold it up for taller items like glasses, bowls, plates, etc.

The edge of the Cup Shelf is designed to hold stemware in place. Taller stemware will fit better on the right side as the upper rack is deeper on this side.

The Folding Tines located in the front right corner provide convenient loading space for large, bulky items like pots and pans or mixing bowls.

To lower tines, carefully push the tines out of each holder toward the center of the rack and lay the tines down.

The Cup Clips located in the center of the upper rack can be used to hold light-weight plastic items, cooking utensils, knives, etc. in place. Clip the item between the tine and the clip.

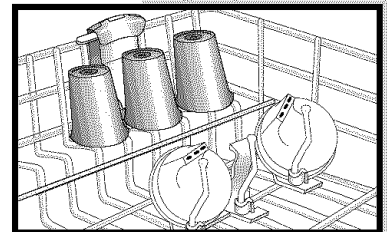
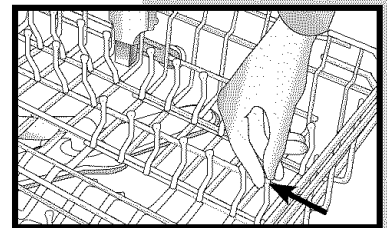
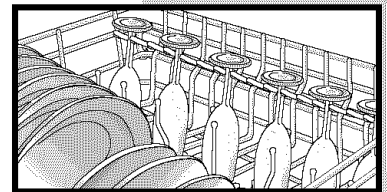
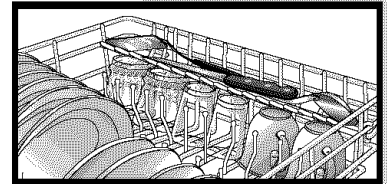

12 Loading

LOWER RACK

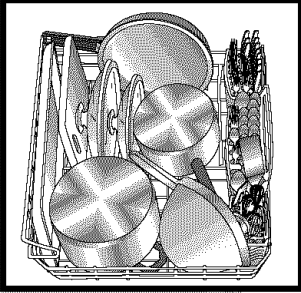

A variety of items such as dinner plates, mixing bowls, pots and pans and baking dishes can be loaded in this rack.

Tall items such as bakeware and large platters can be placed on the left side.

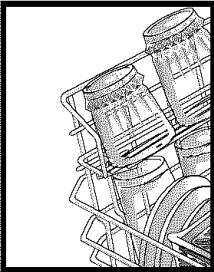
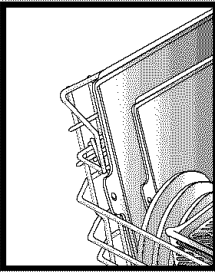

With the Cup Shelves raised, thin items like cookie sheets or pizza pans may be placed along the left side. With the shelves down, two levels of glasses and cups can be loaded.

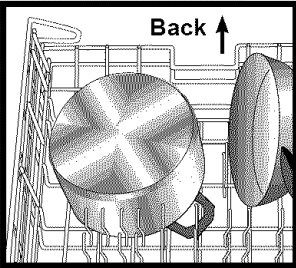

Positioning the Folding Tines flat provides convenient loading space for large, bulky items like pots and pans or mixing bowls.

LOADING THE SILVERWARE BASKET

CAUTION

Cut Injury. Load sharp items (knives skewers, etc.) pointing down.
Failure to do so may result in injury.

Load the silverware basket while it is in the bottom rack or take the basket out for loading on a counter or table.

Place small items like baby bottle caps, jar lids, corn cob holders etc., in a covered section. Close the cover to hold small items in place.

Use suggested loading patterns, as shown, to increase washability of your silverware.

Be sure nothing protrudes through the bottom of basket or rack to block the spray arm.

Do not mix silver and stainless to avoid damaging the silver finish.

The silverware basket can be separated and placed in several locations in the bottom rack. Load silverware in all sections or just one, depending on your load.

When covers are up, mix items in each section of the basket with some pointing up and some down to avoid nesting. Water spray cannot reach nested items.

To remove small basket:

1. Hold the center basket and one small basket. Slide the small basket back to release the tabs from the corresponding slots.
2. Pull the baskets apart.

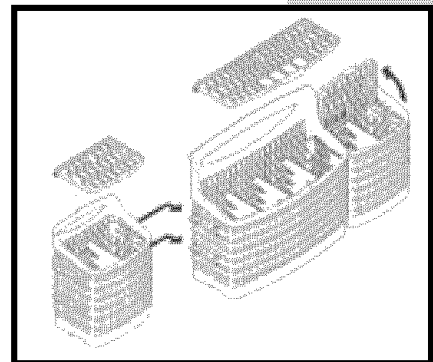
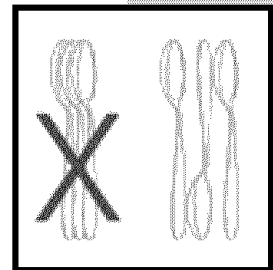
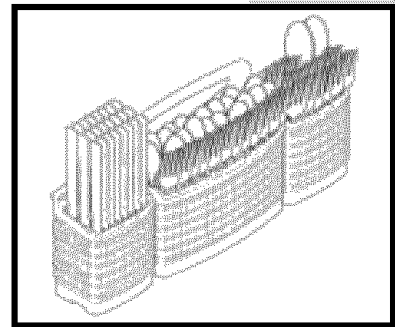

14 Loading

ADJUSTABLE UPPER RACK

The Adjustable Upper Rack can be raised or lowered to accommodate taller plates, platters, pans, etc. optimizing usable space in both upper and lower racks. Full-size dinner plates can be loaded in the upper rack if it is in the lower position. **Always** adjust the upper rack before loading.

Adjusters

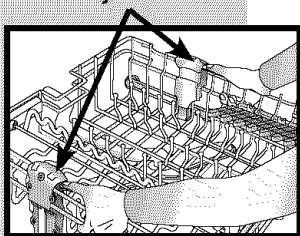

To lower the rack:

1. Pull the rack fully out.
2. Place thumbs on each lever on the adjuster while holding rack with hands.
3. Press down on the levers with thumbs and push rack down. The rack will come to a stop when it is in position.

To raise the rack:

1. Pull the rack fully out.
2. Place hands on both sides and lift up until rack comes to a stop and latches in place.

IMPORTANT

- The dishwasher will not operate correctly if the wash arm is not aligned with one of the water inlet holes on back wall of the dishwasher.
- The left and right side adjusters on the racks must both be fully in the upward or downward position for proper connection.

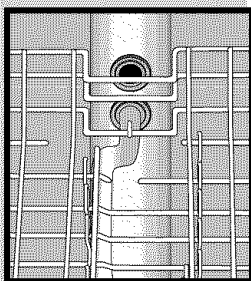

REMOVING THE UPPER RACK

The rack can be removed when tall or oversized items need to be loaded into the lower rack. Unload the rack before removing it from the dishwasher.

Tab Lock

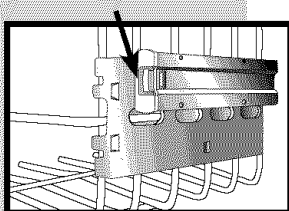

To remove rack with tab-lock rack stops:

1. Roll the rack 1/3 to 1/2 of the way out.
2. Locate the rack stops at the end of each track. Squeeze the tab in the middle of the rack stop and pull the rack stop straight out. Take care to support the rack while removing the rack stops.
3. Roll the rack all the way out of the track and remove from the dishwasher.

To replace:

1. Replace the dishwasher rack by guiding the wheels into the tracks.
2. Push each rack stop squarely into the end of the track until the catch pops into the small hole on the side of the track.

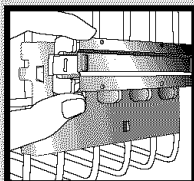

HOT WATER

For optimal cleaning and drying results, hot water is necessary. The incoming water temperature should be at least 120° F (49° C) to properly activate the detergent and melt greasy food soils.

To check the incoming water temperature, turn on the hot water faucet nearest the dishwasher and let it run into a glass in the sink. Place a candy or meat thermometer in the glass and check the temperature once it has stopped rising. If temperature is below 120° F (49° C), have a qualified person raise the water heater thermostat setting.

DETERGENT

Use a detergent designed specifically for use in an automatic dishwasher. Be sure it is fresh. Store granular detergent in a cool, dry place (*not under the sink*) out of reach of children.

Recommended Amount

Too little detergent results in poor cleaning, hard water filming/spotting and poor drying. Too much detergent can cause permanent etching/cloudiness.

Suds can cause the dishwasher to overflow. Measure the detergent carefully and use only detergents designed for use in a dishwasher. Less detergent is needed in soft water. Try another brand of detergent if sudsing continues.

Water Hardness*	Soil Level	Pre-Wash Detergent	Main Detergent
Soft (0-4 gpg)	Light Soil	2 tsp	6 tsp
	Normal Soil	4 tsp	6 tsp
	Heavy Soil	4 tsp	7 tsp
Medium (5-9 gpg)	Light Soil	4 tsp	6 tsp
	Normal Soil	4 tsp	6 tsp
	Heavy Soil	5 tsp	7 tsp
Hard (10-12 gpg)	All Levels	5 tsp	8 tsp

The amount of detergent to use is determined by the hardness of the water and soil level of the load. Refer to the following chart for detergent usage recommendations.

*Your local water utility or state university extension service can tell you the degree of water hardness in your area.

In extremely hard water conditions (13 grains per gallon or more*), it is difficult to achieve good results with any dishwasher. A mechanical water softener may be necessary to improve water quality, detergent effectiveness, and protect the dishwasher parts from the damage that hard water can cause.

CYCLES



Choose the cycle that best describes your dishload by pressing the corresponding touchpad. (See page 8, **Operation**, for how to begin the cycle).

Cycle	Description	Time (Approx. Minutes)	Number of Washes/Rinses
Heavy	Long cycle for heavy food soils.	132	2 washes/3 rinses
Normal	Medium cycle for average food soils. Precision Clean™ Turbidity Sensor is active with this cycle.	97-117	1-2 washes*/1-2 rinses*
China	Short cycle for light food soils.	82	1 wash/2 rinses
Auto	Designed to select the number of water fills best suited for the soil level of each load. Precision Clean™ Turbidity Sensor is active with this cycle.	94-128	1-2 washes*/2-3 rinses*
Rinse	Rinses dishes being held until there is a full load.	9	1 rinse
Short	Quick cycle for light food soils. Does not include drying time.	38	1 wash/2 rinses

* Number of fills will vary depending on the soil level of each load.

IMPORTANT

- Depending on water temperature, there may be time added to the cycle to bring water up to temperature.
- Only the following certified cycles have been designed to meet NSF requirements (NSF/ANSI 184 Residential Dishwasher) for sanitization: Auto, Heavy, Normal and China.

18 Cycles, Options & Lights

OPTIONS

In addition to choosing a cycle from page 17, choose as many available options as are needed for your dishload.

Option	Description	Available With Cycles
Hi Temp	Hi Temp provides additional heat during the wash portion of the cycle, which ensures proper water temperature for better cleaning and drying results. It also adds an additional rinse to the cycle which improves results in hard water situations.	All cycles (except Rinse)
Sanitize	Sanitizes dishware. When cycle monitor recognizes that the proper conditions have been met, Sanitized light will activate at the end of the cycle. Sanitization may not be achieved if there is an interruption of the cycle, power failure or if the incoming water temperature is below 120° F (49° C).	Heavy* Normal* China* Auto*
Air Dry	When Air Dry is selected, towel drying of some items such as plastic and items with non-stick surfaces may be necessary and more moisture may be noticed adhering to the dishwasher interior. Vapor will escape even if Air Dry is selected.	All cycles (except Rinse)
Start/Cancel	Starts and stops dishwasher. See page 8 under Operation: Operating the Dishwasher , for explanation.	All Cycles
Delay	Used to automatically start the cycle at a later time. See page 19 for instructions.	All Cycles
Child Lock Option	Locks control touchpad to prevent unwanted use. See page 20 for instructions.	All Cycles

* Only these cycles have been designated to meet NSF requirements (NSF/ANSI 184 Residential Dishwasher) for sanitization.

DELAY



The Delay option can be used to automatically start the cycle at a later time to reduce daytime heat buildup in the home or to take advantage of reduced energy costs if available in your area. This option is also useful for conserving hot water at times of high household usage (showers, laundry).

To set up a Delay:

1. Select the appropriate cycle and options for the load. Close the door.
2. Press the **Delay** pad until the desired amount of delay time is selected.
3. The Delay indicator will flash until the **START/Cancel** pad is pressed.
4. As soon as the **START/Cancel** pad is pressed, the flashing will stop and the delay time will begin counting down. The Delay indicator will remain lit until the delay time has counted down.
5. The cycle will automatically start as soon as the delay time expires.

IMPORTANT

- If 30 seconds elapse between setting the cycle and options and pressing the **START/Cancel** pad, the dishwasher will turn off.

To cancel a Delay:

When the delay is counting down, press the **Delay** pad again. The indicator light will go out and the cycle will start or resume immediately.

To cancel a Delay and the cycle:

- Press **START/Cancel** once to drain and turn off the dishwasher.
- Or
- Press **START/Cancel** twice to turn dishwasher off without draining.

CHILD LOCK OPTION

The control touchpads can be locked to prevent unwanted use. If this feature is activated between cycles, the dishwasher cannot be operated until the controls are unlocked. If desired, the controls can be locked after a cycle or delay has started.

Setting the Child Lock:

1. Press the **Air Dry** pad for three seconds.
2. An indicator light next to the lock graphic will illuminate when the controls are locked.

To Cancel:

1. Press the **Air Dry** pad for three seconds.
2. The indicator light will go off.

IMPORTANT

- If a cycle or option pad is pressed after the controls have been locked, the indicator light next to the lock graphic will flash five times.
- This option does not lock the door, only the dishwasher controls.

LIGHTS/DISPLAY

Indicator	Description
Clean Light	Illuminates at the end of the cycle and remains lit until the door has been open for 30 seconds continuously.
Sanitized Light	Illuminates at the end of the cycle when conditions have been met to achieve sanitization. The light will remain lit until the door has been open for 30 seconds continuously.

IMPORTANT

- When Sanitize is selected, cycles are monitored to assure sanitization. The Sanitized light will not activate if sanitization requirements are not met. This could happen if the cycle is interrupted, power failure occurs or incoming water temperature is below 120° F (49° F).
- The Clean and Sanitized indicator lights will not relight after a power failure until after the next cycle is run.

GENERAL RECOMMENDATIONS

- The dishwasher interior is normally self-cleaning. Periodically check the bottom of the dishwasher tub to see if any large particles remain.
- Wipe the edge of the inner door liner to remove any food soil splashes which occurred during loading.
- When cleaning stainless steel, always wipe with the grain. **Never** use products containing chlorine bleach or citric acid.
- The color from some tomato-based food soils may occasionally adhere to various components of the dishwasher interior, causing temporary discoloration.

To minimize this:

- Remove excess tomato-based food soils from dishes, before loading.
- Run the **Heavy** cycle when washing loads containing tomato-based food soils.
- Use a dishwasher detergent that contains chlorine to better fight staining.

OUTSIDE

Occasionally wipe the outside surfaces of your dishwasher with a mild nonabrasive detergent and water. Rinse and dry.

Stainless Steel Door

Clean the stainless steel door and handle with hot, soapy water and a dishcloth. Rinse with clean water and a cloth. Do not use harsh scrubbing cleaners. Use only kitchen cleaners made especially for cleaning stainless steel.

22 Care & Cleaning

STORAGE/MOVING

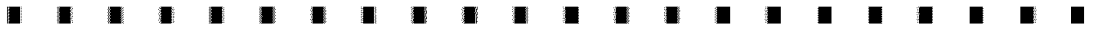

Fill detergent cup with a fresh-scented dishwasher detergent or baking soda and select the **Normal** cycle. Allow the dishwasher to complete the cycle. Then turn the water supply off and drain the dishwasher. To drain, press the **START/Cancel** pad once to activate the dishwasher. Press **START/Cancel** again to activate the drain. Operate the drain twice to ensure most of the water is removed. Last, disconnect the electrical supply and prop open the door.

When turning the water supply to the home off, the water shut-off at the dishwasher must be turned off also.



Check these points to help save you time and money.

Problem	Solution
Dishwasher will not fill	<ul style="list-style-type: none">• Press the START/Cancel pad to start the dishwasher.• Be sure door is latched securely.• Be sure the water is turned on.• Check that the pad is properly selected for a cycle.• Check your home's circuit breaker or fuse box.• Check inlet hose for a kink.• Check water valve inlet for sediment and clean if necessary.
Dishwasher will not drain/water in tub bottom	<ul style="list-style-type: none">• If hooked up to a food waste disposer, be sure the knock-out is removed from the disposer inlet.• Check for food obstruction in the drain or disposer.• Check drain hose for a kink.• Check your home's circuit breaker or fuse box.• Check that the cycle is completed.
Dishwasher adds water at end of cycle	<ul style="list-style-type: none">• This is normal. The sensor in the pump must stay submerged so a short fill of water is added after the cycle's last drain.
Detergent cup is not empty	<ul style="list-style-type: none">• Check that the cycle is completed.• Be sure dispenser is not blocked.• Use fresh detergent stored in a cool, dry place.
Dishwasher seems noisy	<ul style="list-style-type: none">• A water valve hiss during fill is normal.• Water circulation sounds are normal.• A thumping sound may be a wash arm bumping an item that is extending beyond the racks. Readjust load to avoid obstructing wash arm.• Chopping or grinding sounds may be heard as the internal food disposer chops hard items like fruit seeds, nuts, etc.• Humming during the drain is normal.• A snap noise is the detergent cup lid hitting the door liner when the dishwasher door is opened at the end of the cycle. This is normal.• Proper installation affects the noise level.
Cycle takes too long	<ul style="list-style-type: none">• Sanitize has been selected and the cycle is extended to heat water.• Check to see that the incoming water temperature is 120° F (49° C)
Dishwasher has an odor	<ul style="list-style-type: none">• Run dishes being held in the dishwasher through a Rinse cycle.• Many dishwashers have a "new" smell when first installed. This will dissipate with use.• Dishwasher may not be draining properly. (See Dishwasher Will Not Drain section.)• For a strong odor, place baking soda in both sides of the detergent cup. Select China cycle and allow the water to circulate for about 10 minutes. Interrupt the cycle by unlatching the door and let it stand overnight. Restart the dishwasher by latching the door and allow it to complete the cycle. Another alternative is to use a dishwasher cleaning product such as Jet-Dry Dishwasher Cleaner*.

*Brand names are trademarks of the respective manufacturer.

24 Troubleshooting

Check these points to help save you time and money.

Problem	Solution
Dishwasher leaks	<ul style="list-style-type: none">• Check that the dishwasher is level. (Refer to the Installation Instructions.)• Suds can cause the dishwasher to overflow. Measure the detergent carefully and use only detergents designed for use in a dishwasher. Less detergent is needed in soft water. Try another brand of detergent if sudsing continues. (pg. 15)• Follow directions closely on how to add a forgotten item (pg. 9).• To avoid rinse aid leaking from the dispenser, be sure the lid is securely attached.
Indicator lights flashing	<ul style="list-style-type: none">• All active display indicators flash if the door is opened during a running cycle or delay.• The currently selected cycle flashes if an attempt is made to change the cycle after cycle "lock-in".• The locked indicator flashes if a pad is pressed while the child lock is enabled. (pg. 20)
Glasses are cloudy/spotted	<ul style="list-style-type: none">• Select Hi Temp option.• Check water temperature. Incoming water should be 120° F (49° C).• Always use a rinse aid.• Confirm that the cloudiness is removable by soaking the item in white vinegar for approximately 5 minutes. If removed, the problem is due to hard water. Adjust detergent amount being used to match water hardness (pg. 15). Be sure detergent is fresh, stored properly and is a high quality brand.• If cloudiness is not removable, it is etching. This is an erosion of the surface of the glassware and can be caused by water that is too hot, from using too much detergent or by prewashing. Detergent needs food soil to act upon. If etching has occurred, the glassware is permanently damaged. To prevent further etching, adjust the detergent amount to match the water hardness, stop prewashing, and use water heating options only when incoming water temperature is below 120° F (49° C).
Dishware is chipped	<ul style="list-style-type: none">• Load dishes according to instructions so they do not strike each other (pgs. 11-12).• Washing fine antique china/crystal in the dishwasher is not recommended. (pg. 7)• Do not load glasses over the tines.• Do not overload

*Brand names are trademarks of the respective manufacturer.

Cont.

Check these points to help save you time and money.

Problem	Solution
Food soil remains on dishes	<ul style="list-style-type: none">• Check water temperature. Incoming water should be 120° F (49° C).• Run hot water at the sink before starting the dishwasher.• Check water hardness and adjust detergent amount accordingly (pg. 15).• Use fresh detergent stored in a cool dry place.• Select proper cycle for the soil level (pg. 17).• Select proper option, Hi Temp.• Make sure the upper rack wash arm connector is correctly aligned in one of the water inlet holes (pg. 14).• Load items so they do not block the wash arms (pgs. 11-12).• Load the utensil basket with knife handles up and spoon and fork handles down.• Do not place glasses over tines.• Before loading, scrape off burnt-on foods and wipe the starchy film from utensils used with pasta, rice and oatmeal. These soils require more energy than the rest of the load to clean.
Items washed in the dishwasher or the dishwasher tub itself is stained/discolored	<ul style="list-style-type: none">• Aluminum utensils or pans can leave marks when they rub against other items. Leave a slight space between items.• Iron deposits in the water can leave a yellow, brown or orange film on dishes or the dishwasher tub. A rust filter may be needed. Check with a water treatment company.• Separate silver or silver-plated silverware from stainless steel. These metals can be damaged by contact with each other during washing.• Color from tomato sauces may adhere to the interior parts of the dishwasher (pg. 21). If light staining has occurred, leave the door open to oxidize the stain away. Use a dishwasher detergent that contains chlorine to better fight staining.• Certain dishwasher detergents may stain silver. Try another brand of detergent.
Items not properly dried/ moisture is present on the dishwasher interior after the dry cycle	<ul style="list-style-type: none">• Be sure Air Dry is not selected.• Water droplets may form on the inner door as part of the drying process.• Use a rinse aid separate from the detergent like Jet Dry* or Cascade Rinse Aid* regularly to improve drying. Turn the rinse aid selector toward the MAX setting.• Check water temperature. Incoming water should be 120° F (49° C).• Select Sanitize option.• Increase detergent amount to match water hardness (pg. 15).• Load properly. (pgs. 11-12)• Plastic and items with non-stick surfaces are difficult to dry because they have a porous surface which tends to collect water droplets. Towel drying may be necessary.• Glasses and cups with concave bottoms hold water and require towel drying. Locate these items on the more slanted side of the rack for improved results.

*Brand names are trademarks of the respective manufacturer.

26 Troubleshooting

Check these points to help save you time and money.

Problem	Solution
Sanitized light does not illuminate at the end of the cycle	<ul style="list-style-type: none">• Sanitize was not selected.• Sanitization can only be achieved with the Auto, Heavy, Normal or China cycles.• Sanitization may not be achieved if there is an interruption of the cycle, power failure or if incoming water temperature is below 120° F (49° C).
Dishwasher door will not close	<ul style="list-style-type: none">• Be sure adjustable racks are properly adjusted to upper or lower position (pg. 14).

*Brand names are trademarks of the respective manufacturer.

Warranty Information

DISHWASHER WARRANTY

(YOUR DISHWASHER IS PROTECTED BY THIS WARRANTY)



	WARRANTY PERIOD	THROUGH OUR AUTHORIZED SERVICERS, WE WILL:	THE CONSUMERS WILL BE RESPONSIBLE FOR:
1-YEAR FULL WARRANTY	One year from original purchase date.	Pay all costs for repairing or replacing any parts of this appliance which prove to be defective in materials or workmanship.	Costs of service calls that are listed under NORMAL RESPONSIBILITIES OF THE CONSUMER*
5-YEAR LIMITED WARRANTY	Second through 5th years from original purchase date.	Replace any electronic control that fails due to manufacturing defect. Replace any original upper or lower nylon coated rack that peels or rusts due to a manufacturing defect. Replace major components in the water distribution system which fails due to a manufacturing defect. This includes the motor, pump and lower wash arm, upper spray arm with associated supply tube and filter assembly. Associated inlet and chain plumbing parts are not covered by this warranty.	Costs for pickup and delivery of the appliance required because of service; and all costs for labor and transportation. Associated inlet and drain plumbing parts.
LIFETIME LIMITED WARRANTY	Lifetime of the product.	Provide a replacement tub or door liner if the original tub or door liner fails to contain water because of a manufacturing defect.	Door seals, any cost for pickup and delivery of the appliance required because of service; and all costs for labor and transportation.
LIMITED WARRANTY (Applicable to the State of Alaska)	Time periods listed below.	All of the provisions of the full warranties above and the exclusions listed below apply.	Cost of the technician's travel to the home and any costs for pickup or delivery of the appliance required because of service.

In the U.S.A., your appliance is warranted by Electrolux Major Appliances North America. We authorize no person to change or add to any of our obligations under this warranty. Our obligation for service and parts under this warranty must be performed by us or an authorized Electrolux Major Appliances North America servicer.

***NORMAL RESPONSIBILITIES OF THE CUSTOMER**

This warranty applies only to products in ordinary household use, and the consumer is responsible for the items listed below:

1. Proper use of the appliance in accordance with instructions provided with the product.
2. Proper installation by an authorized servicer in accordance with instructions provided with the appliance and in accordance with all local plumbing, electrical and/or gas codes.
3. Proper connection to a grounded power supply of sufficient voltage, replacement of blown fuses, repair of loose connections or defects in house wiring.
4. Expenses for making the appliance accessible for servicing, such as removal of trim, cupboards, shelves, etc., which are not a part of the appliance when it was shipped from the factory.
5. Damage to finish after installation.

EXCLUSIONS

This warranty does not cover the following:

1. CONSEQUENTIAL OR INCIDENTAL DAMAGES SUCH AS PROPERTY DAMAGE OR INCIDENTAL EXPENSES RESULTING FROM ANY BREACH OF THIS WARRANTY OR ANY IMPLIED WARRANTY.
Note: Some states do not allow the exclusion or limitation of incidental or consequential damages, so this limitation or exclusion may not apply to you.
2. Service calls which do not involve malfunction or defects in workmanship or material, or for appliances not in ordinary household use. The consumer shall pay for such service calls.
3. Damages caused by services performed by persons other than from Electrolux Major Appliances North America or their authorized servicers; use of parts other than genuine Electrolux parts; parts obtained from persons other than such servicers; or external causes such as abuses, misuse, inadequate power supply or acts of God.
4. Products whose serial numbers have been removed or altered and cannot be readily determined.

IF YOU NEED SERVICE

Keep your bill of sale, delivery slip or some other appropriate payment record. The date on the bill establishes the warranty period should service be required. If service is performed, it is in your best interest to obtain and keep all receipts. This written warranty gives you specific legal rights. You may also have other rights that vary from state to state. Service under this warranty must be obtained by contacting Electrolux Major Appliances North America.

This warranty only applies to products that are subject to change without notice. All warranties are made by Electrolux Major Appliances North America.