

Owner's Manual

CRAFTSMAN[®]

SLEEVE HITCH

Model No. 486.24536

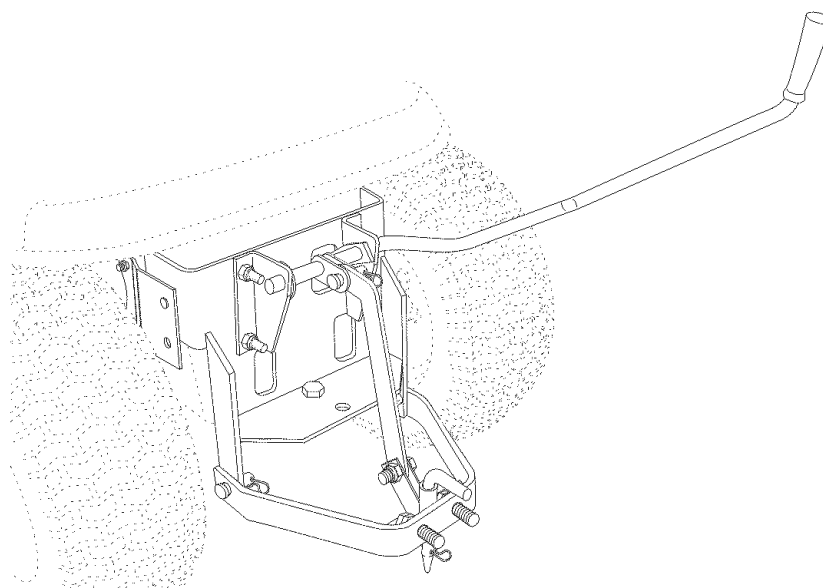

CAUTION:

Before using this product, read this manual and follow all Safety Rules and Operating Instructions.

IMPORTANT - READ THIS FIRST!!!

For Missing Parts or Assembly Questions
Please Call 866-576-8388
Mon.-Fri. 7 am - 5 pm CST.

FAX 217-728-2032 or e-mail info@agri-fab.com

Missing parts will be sent UPS in 24 hours directly to your home.

- Safety
- Assembly
- Operation
- Maintenance
- Parts

Sears, Roebuck and Co., Hoffman Estates, IL 60179 U.S.A.
www.sears.com/craftsman

TABLE OF CONTENTS

SAFETY RULES.....	2	MAINTENANCE	6
FULL SIZE HARDWARE CHART.....	3	REPAIR PARTS ILLUSTRATION.....	7
CARTON CONTENTS.....	4	REPAIR PARTS LIST	7
ASSEMBLY.....	4	PARTS ORDERING/SERVICE	Back Page
OPERATION.....	6		

WARRANTY

LIMITED ONE YEAR WARRANTY ON CRAFTSMAN SLEEVE HITCH

For one year from the date of purchase, when this sleeve hitch is maintained and lubricated according to the operating and maintenance instructions in the owner's manual, Sears will repair any defect in material or workmanship free of charge. If this sleeve hitch is used for commercial or rental purposes, this warranty applies for only 90 days from the date of purchase.

This warranty does not cover repairs necessary because of operator negligence or abuse, including the failure to maintain the equipment according to instructions contained in the owner's manual.

WARRANTY SERVICE IS AVAILABLE BY CONTACTING THE NEAREST SEARS SERVICE CENTER/DEPARTMENT IN THE UNITED STATES.

This warranty applies only while this product is in the United States.

This warranty gives you specific legal rights, and you may also have other rights which vary from state to state. Sears, Roebuck and Co. D/817 WA. Hoffman Estates, Chicago, IL 60179



SAFETY



Any power equipment can cause injury if operated improperly or if the user does not understand how to operate the equipment. Exercise caution at all times, when using power equipment.

- Read this owners manual and your vehicle and implement owners manuals before using this hitch.
- Do not allow children to operate vehicle or sleeve hitch.
- Do not allow adults to operate the vehicle or sleeve hitch without proper instructions.
- Do not allow anyone to ride on sleeve hitch.
- Always place sleeve hitch in lowered position when attaching an implement.
- Before lowering and operating the implement, be sure no one is near the area of operation.
- Lower the sleeve hitch and implement when leaving vehicle unattended.
- Vehicle braking and stability may be affected. Drive slowly when sleeve hitch and implement are in raised position. **Stay off of steep slopes.**
- Keep all nuts and bolts tight and be sure the equipment is in safe operating condition.



Look for this symbol to point out important safety precautions. It means — **Attention!! Become alert!! Your safety is involved.**

The model number and serial numbers will be found on a decal attached to the frame.

You should record both the serial number and the date of purchase and keep in a safe place for future reference.

MODEL NUMBER: 486.24536

SERIAL NUMBER: _____

DATE OF PURCHASE: _____

ACCESSORIES

The following accessories are available at most Sears retail outlets.

ELECTRIC ASSIST KIT - MODEL 486.24545

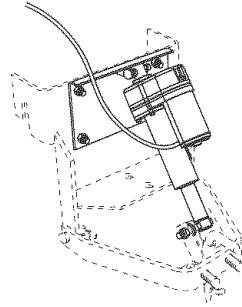

HARDWARE PACKAGE CONTENTS

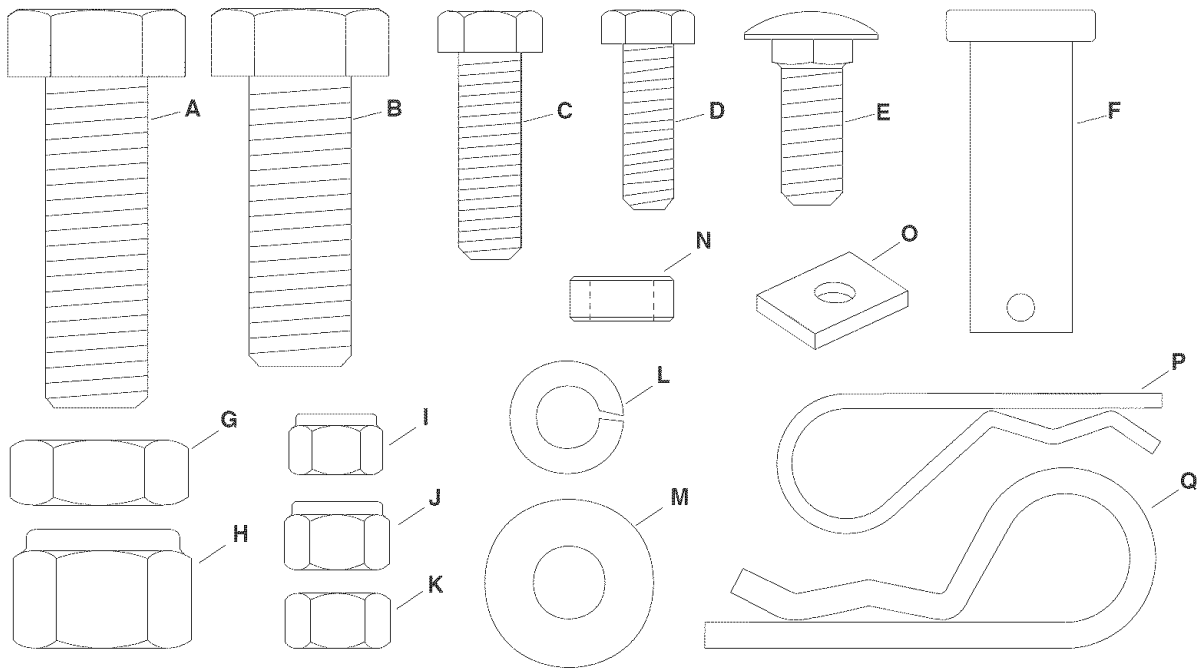

KEY	QTY.	DESCRIPTION	KEY	QTY.	DESCRIPTION
A	2	Hex Bolt, 5/8" x 2"	J	4	Nylock Nut, 3/8"
B	2	Hex Bolt, 5/8" x 1-3/4"	K	4	Hex Nut, 3/8"
C	4	Hex Bolt, 3/8" x 1-1/4"	L	4	Lock Washer, 3/8"
D	1	Hex Bolt, 5/16" x 1"	M	6	Flat Washer, 3/8"
E	4	Carriage Bolt, 3/8" x 1"	N	1	Spacer
F	3	Clevis Pin	O	1	Spacer Plate
G	2	Jam Nut, 5/8"	P	3	3/32" Hair Cotter Pin
H	2	Nylock Nut, 5/8"	Q	1	5/32" Hair Cotter Pin
I	1	Nylock Nut 5/16"			

NOTE: Bolt (C), Lock Washer (M) and Nut (H) will not be used unless the mounting holes in the tractor do not already contain bolts and nuts.

ASSEMBLY

CARTON CONTENTS

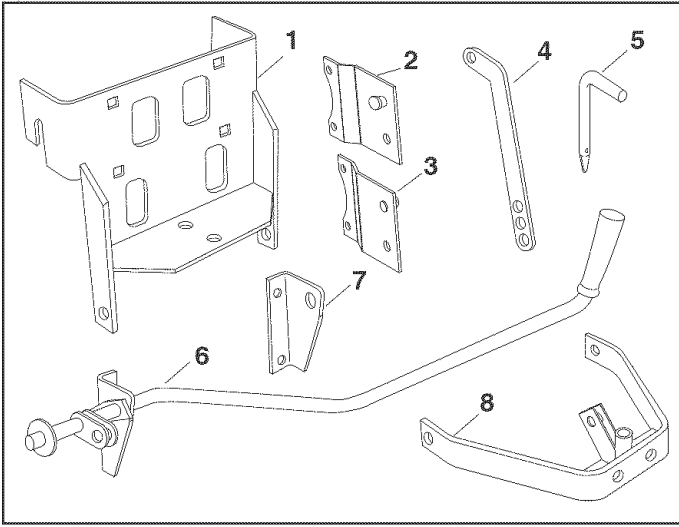

1. Sleeve Hitch Frame Assembly
2. Mounting Bracket (R.H.)
3. Mounting Bracket (L.H.)
4. Lifting Link Plate
5. Hitch Pin
6. Lift Lever Assembly (with R.H. Pivot Bracket)
7. L.H. Pivot Bracket
8. Sleeve Hitch Lift Assembly

TOOLS REQUIRED FOR ASSEMBLY

- (1) 1/2" Wrench or Adjustable Wrench
- (2) 9/16" Wrenches or Adjustable Wrenches
- (1) 15/16" Wrenches or Adjustable Wrenches

- Assemble a 5/16" x 1" hex bolt, a spacer and a 5/16" nylock nut to the three position slot in the R.H. pivot bracket on the left lever assembly. Use the position closest to the bend in the bracket (lowest implement depth setting). See figure 1.

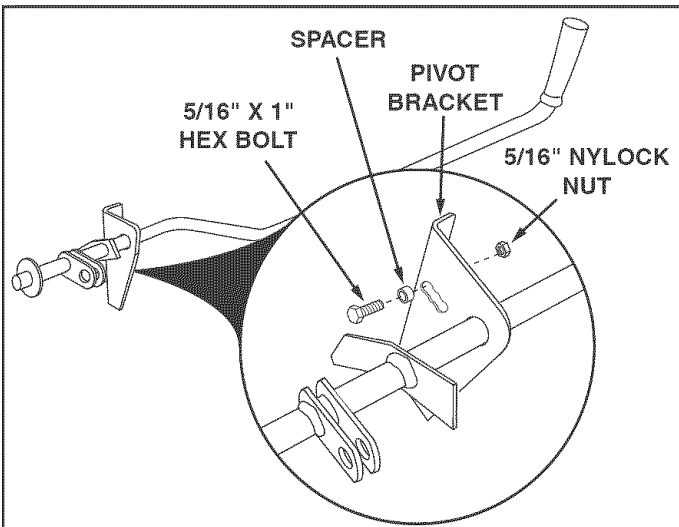

FIGURE 1

- Remove the nuts from the two bolts in each side of the tractor, leaving the bolts in place. See figure 2.
- Attach the left (LH) and right (RH) Mounting Brackets to the bolts using the original nuts and two 3/8" flat washers. The brackets should angle outward with the weld pins at the top of the brackets facing inward. See Figure 2.

NOTE: If no bolt and nut are present in a hole, use a 3/8" x 1-1/4" hex bolt, 3/8" lock washer and 3/8" hex nut to attach the Mounting Bracket to the hole.

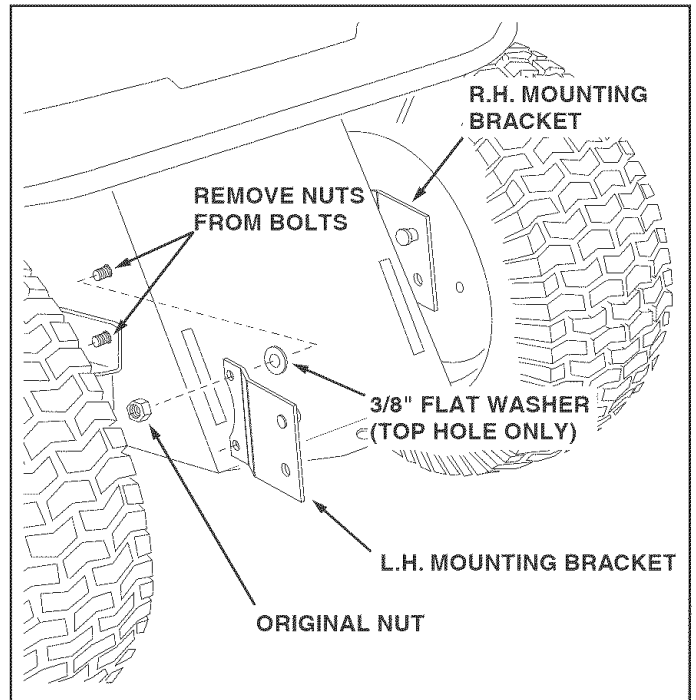

FIGURE 2

- Place the L.H. Pivot Bracket onto the end of the Lift Lever Assembly (the R.H. Pivot Bracket comes already installed on the assembly). See Figure 3.
- Attach the R.H. and L.H. Pivot Brackets to the Sleeve Hitch Frame Assembly using four 3/8" x 1" carriage bolts and 3/8" nylock nuts. See Figure 3.

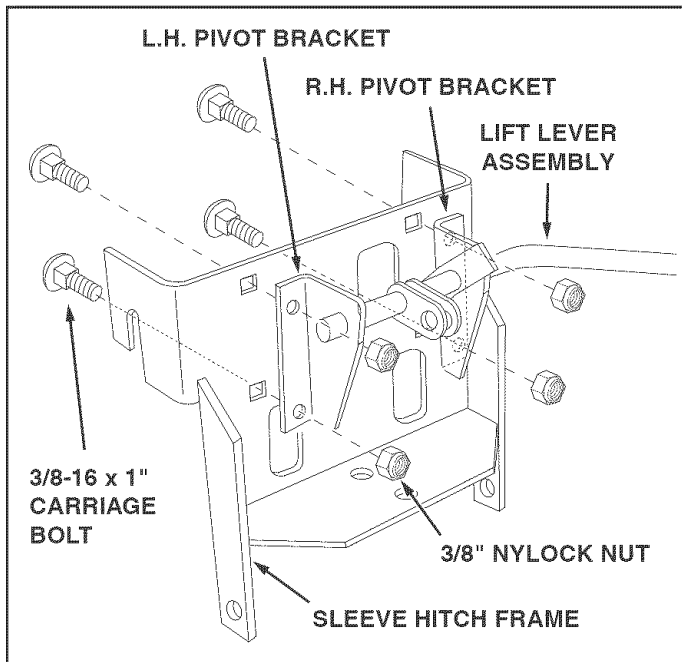

FIGURE 3

- Hook the Sleeve Hitch Frame Assembly onto the weld pins in the mounting brackets. Attach the bottom of the Assembly to the tractor hitch using a 5/8" x 1-3/4" hex bolt and a 5/8" nylock nut. See figure 4.

NOTE: If your tractor hitch has ridges that prevent the sleeve hitch assembly from resting flat, place the spacer plate underneath the sleeve hitch assembly.

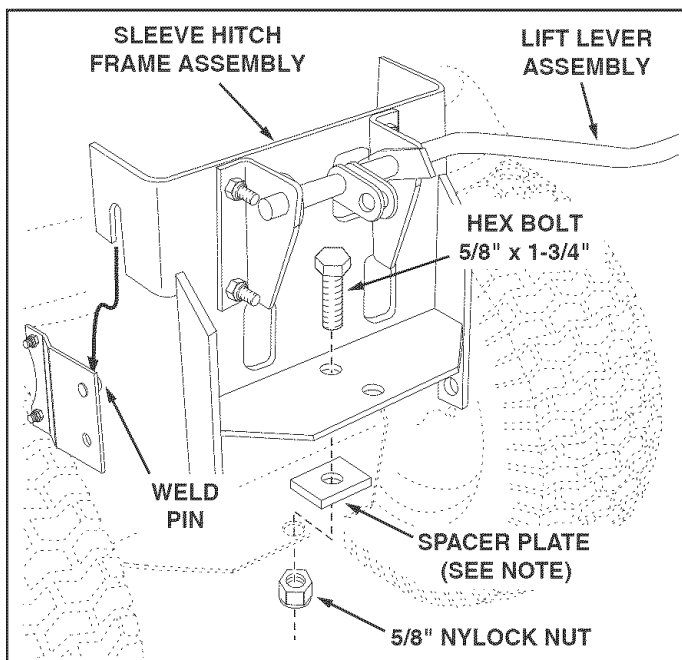

FIGURE 4

- Assemble the two 5/8" jam nuts halfway onto the two 5/8" x 2" hex bolts. Screw the bolts into the nuts that are welded to the Sleeve Hitch Lift Assembly. Tighten the jam nuts against the welded nuts. See figure 5.
- Assemble the lifting link to the Sleeve Hitch Lift Assembly using a 5/8" x 1-3/4" hex bolt and a 5/8" nylock nut. Use the bottom hole in the lifting link (gives the lowest implement depth setting). Tighten the nut only until snug. Do not squeeze the welded arms together. See figure 3. See figure 5.

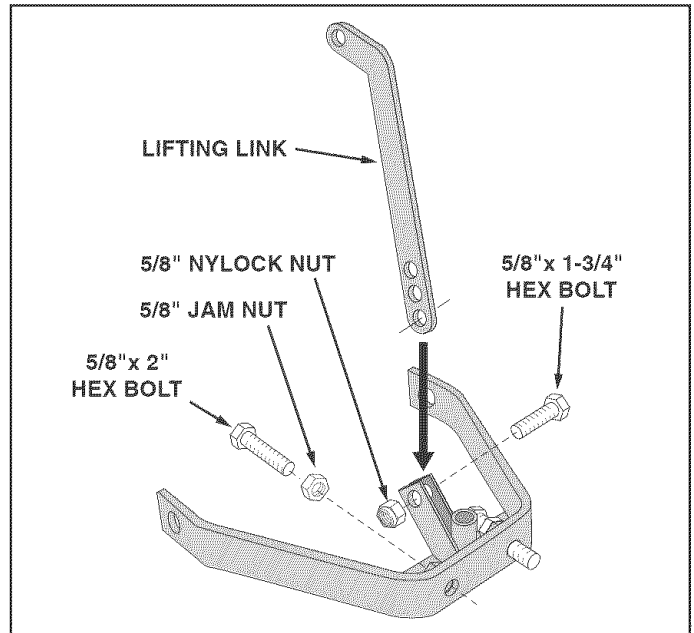

FIGURE 5

- Attach the Sleeve Hitch Lift Assembly to the Sleeve Hitch Frame Assembly using three 5/8" x 1-3/4" clevis pins and 3/32" hair cotter pins as shown in figure 6.
- Install the hitch pin in the sleeve hitch and secure it with the 5/32" hair cotter pin. See figure 6.

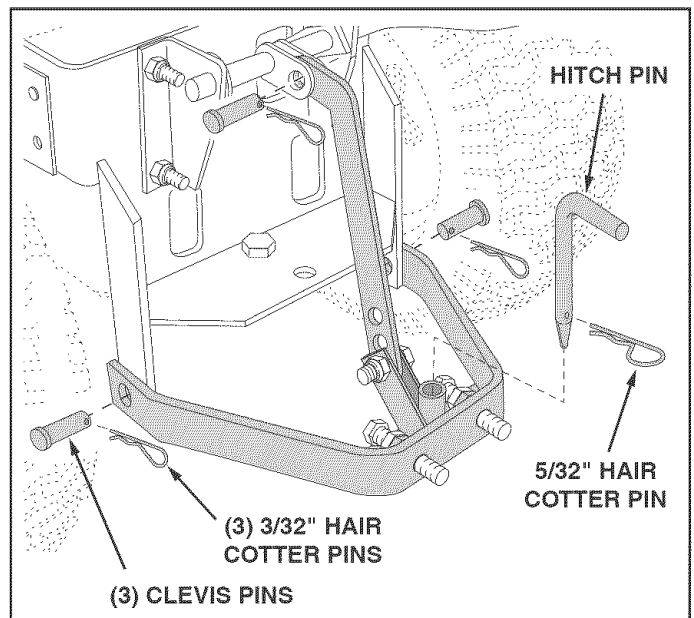

FIGURE 6

OPERATION

- Move the lift lever backward to lower the sleeve hitch.
 - Attach an implement using the sleeve hitch pin. Tighten the 5/8" x 2" stabilizer bolts against the implement hitch and then tighten the jam nuts. See Figure 5 on Page 5.
- IMPORTANT:** Some implements may require that the stabilizer bolts not be tightened. Refer to your implement owner's manual.
- The sleeve hitch is assembled in the lowest position by the assembly instructions. If the implement attached to the sleeve hitch is not level front to back during operation:
 - a. Move the hex bolt in the lifting link to a hole (3 holes available) that gives better levelling.
 - b. For closer adjustment, move the hex bolt assembled in figure 1 to a position in the three position slot that gives better levelling.
 - To tow an implement that has a tow hitch, simply remove three clevis pins and then remove the Sleeve Hitch Lift Assembly from the Sleeve Hitch Frame Assembly.
 - To remove the entire Sleeve Hitch attachment, remove the 5/8" x 1-3/4" hex bolt and 5/8" nylock nut which fasten the bottom of the sleeve hitch to the tractor hitch, then lift the attachment off the tractor.

MAINTENANCE

- Clean off after each use.
- Oil pivot points as needed.
- Store in a dry location.

PARTS

REPAIR PARTS FOR MODEL 486.24536 SLEEVE HITCH

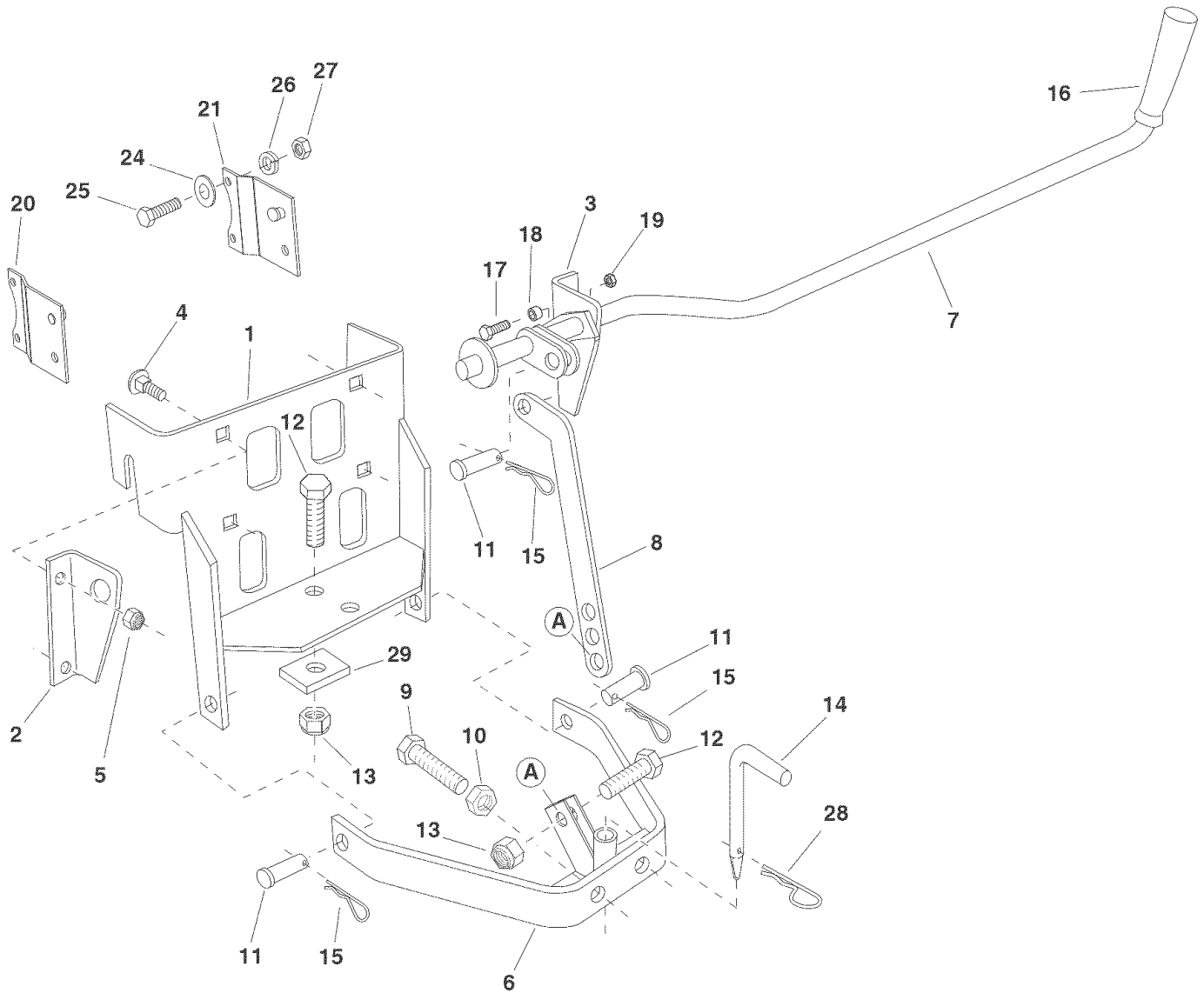

Ref	Part No.	Qty	Description	Ref	Part No.	Qty	Description
1	65409	1	Sleeve Hitch Frame	15	43343	3	Pin, Hair Cotter 3/32"
2	25715	1	Pivot Bracket, L.H.	16	46471	1	Grip, Plastic
3	25714	1	Pivot Bracket, R.H.	17	43063	1	Bolt, 5/16-18 x 1"
4	43350	4	Bolt, Carriage 3/8-16 x 1"	18	23625	1	Spacer
5	HA21362	4	Hex Lock Nut, 3/8-16	19	47810	1	Nylock Nut, 5/16"
6	65404	1	Sleeve Hitch Lift Assembly	20	65370	1	Mounting Bracket, L.H.
7	64625	1	Lift Lever Assembly	21	65369	1	Mounting Bracket, R.H.
8	24732	1	Lifting Link Plate	24	43070	6	Flat Washer
9	47947	2	Bolt, Hex 5/8-11 x 2"	25	43087	4	Bolt, Hex 3/8-16 x 1-1/4"
10	712-0242	2	Hex Jam Nut, 5/8-11	26	43003	4	Lock Washer, 3/8"
11	HA3980	3	Clevis Pin, 5/8" x 1-3/4"	27	43015	4	Hex Nut, 3/8-16
12	47951	2	Bolt, Hex 5/8-11 x 1-3/4"	28	714-0117	1	Pin, Hair Cotter, 5/32"
13	712-0261	2	Nylock Nut, 5/8-11	29	25685	1	Spacer Plate
14	47950	1	Pin, Sleeve Hitch		49814	1	Owner's Manual

Get it fixed, at your home or ours!

For repair of major brand appliances **in your own home...**
no matter who made it, no matter who sold it!

1-800-4-MY-HOMESM Anytime, day or night
(1-800-469-4663)

www.sears.com

To bring in products such as vacuums, lawn equipment and electronics
for repair, call for the location of your nearest **Sears Parts & Repair Center.**

1-800-488-1222 Anytime, day or night

www.sears.com

For the replacement parts, accessories and owner's manuals
that you need to do-it-yourself, call **Sears PartsDirectSM**!

1-800-366-PART 6 a.m. – 11 p.m. CST,
(1-800-366-7278) 7 days a week

www.sears.com/partsdirect

To purchase or inquire about a Sears Service Agreement:

1-800-827-6655

7 a.m. – 5 p.m. CST, Mon. – Sat.

Para pedir servicio de reparación a domicilio,
y para ordenar piezas con entrega a domicilio:

1-888-SU-HOGARSM
(1-888-784-6427)

Au Canada pour service en français:

1-877-LE-FOYERSM
(1-877-533-6937)

