

Installation Instructions

- Safety Labeling & Rules
- Installation Requirements
- Location / Clearances
- Wiring
- Air Distribution
- Ductwork Connections
- Economizer Accessory
- Start-Up
- Maintenance
- Hoisting / Rigging

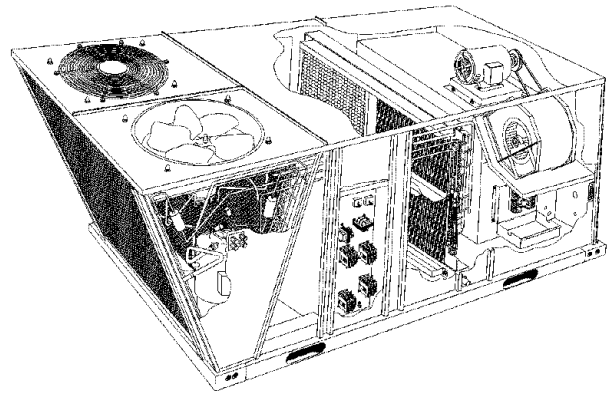

MODELS
PAB240 RAMA20

SINGLE PACKAGE AIR CONDITIONERS
ELECTRIC COOL / ELECTRIC HEAT (OPTIONAL)

Table of Contents

1. Safety Labeling and Signal Words	2
Danger, Warning and Caution	2
Signal Words	2
Signal Words in Manuals	2
Product Labeling	2
Danger Label	2
Warning Label	2
Caution Label	2
2. Unit Dimensions	3
3. Safe Installation Requirements	4
4. Location And Set-up	5
Access Panels	5
Clearances	5
Minimum Clearances to Combustible and non-Combustible Construction (Horizontal Flow)	6
Minimum Clearances to Combustible and non-Combustible Construction (Downflow)	6
Installation	7
Ground Level Installation	7
Rooftop Installation	7
Hoisting	7
Converting to Horizontal Operation	7
Condensate Drain	7
5. Electrical Wiring	9
Line Voltage Wiring	9
Line Connections	9
Converting 230V Units to 208V	9
Field Installed Equipment	10
Low Voltage Wiring	10
Low Voltage Wiring With Economizer Option	10
Thermostat	10
Heat Anticipator	10
Final Check	10
6. Air Distribution System	11
Ductwork	11
Ductwork Connections	11
Filters	11
Circulating Blower	11
Determining Blower Speed	11
7. Adjustable Belt Drive Blower	14
8. Economizer Accessory	16
Static Additions	16

Theory of Operation	16
Sequence of Operation	17
9. Start–up Procedure	18
Blower and Phasing Check	18
Cooling Checks	19
10. Operation And Maintenance Instructions	20
Turning Off the Unit	20
Heating	20
Cooling	20
Starting the Unit After Shutdown	20
Heating	20
Cooling	20
Thermostat Fan Switch Operation	20
Adjusting Room Temperatures	20
Monthly Maintenance and Inspection Checks	21
Air Filters (Factory Installed)	21
Disposable Replacement Filters	21
Cooling Season Checks (Monthly)	21
Condenser Coil	21
Condensate Drain	21
Annual Maintenance and Inspection	21
Circulating Air Blower	21
11. Rigging Instructions	23

1. Safety Labeling and Signal Words

Danger, Warning and Caution

The signal words **DANGER**, **WARNING** and **CAUTION** are used to identify levels of hazard seriousness. The signal word **DANGER** is only used on product labels to signify an immediate hazard. The signal words **WARNING** and **CAUTION** will be used on product labels and throughout this manual and other manuals that may apply to the product.

Signal Words

DANGER - Immediate hazards which **WILL** result in severe personal injury or death.

WARNING - Hazards or unsafe practices which **COULD** result in severe personal injury or death.

CAUTION - Hazards or unsafe practices which **COULD** result in minor personal injury or product or property damage.

Signal Words in Manuals

The signal word **WARNING** is used throughout this manual in the following manner:

WARNING

The signal word **CAUTION** is used throughout this manual in the following manner:

CAUTION

Product Labeling

Signal words are used in combination with colors and/or pictures on product labels. Following are examples of product labels with explanations of the colors used.

Danger Label

White lettering on a black background except the word **DANGER** which is white with a red background.

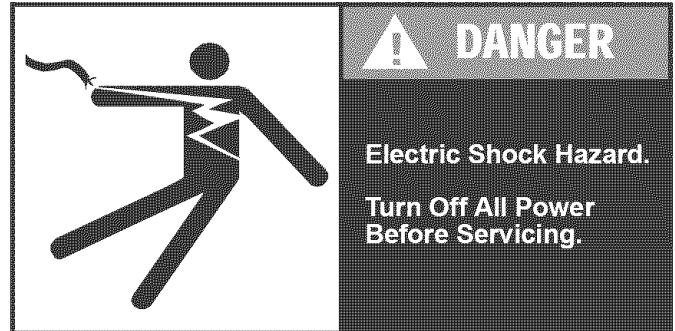

Warning Label

White lettering on a black background except the word **WARNING** which is black with an orange background.

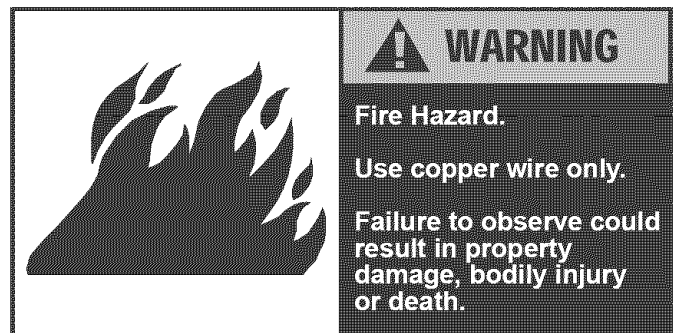

Caution Label

White lettering on a black background except the word **CAUTION** which is black with a yellow background.

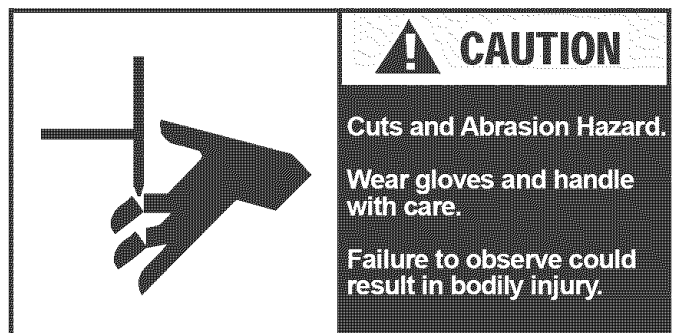

2. Unit Dimensions

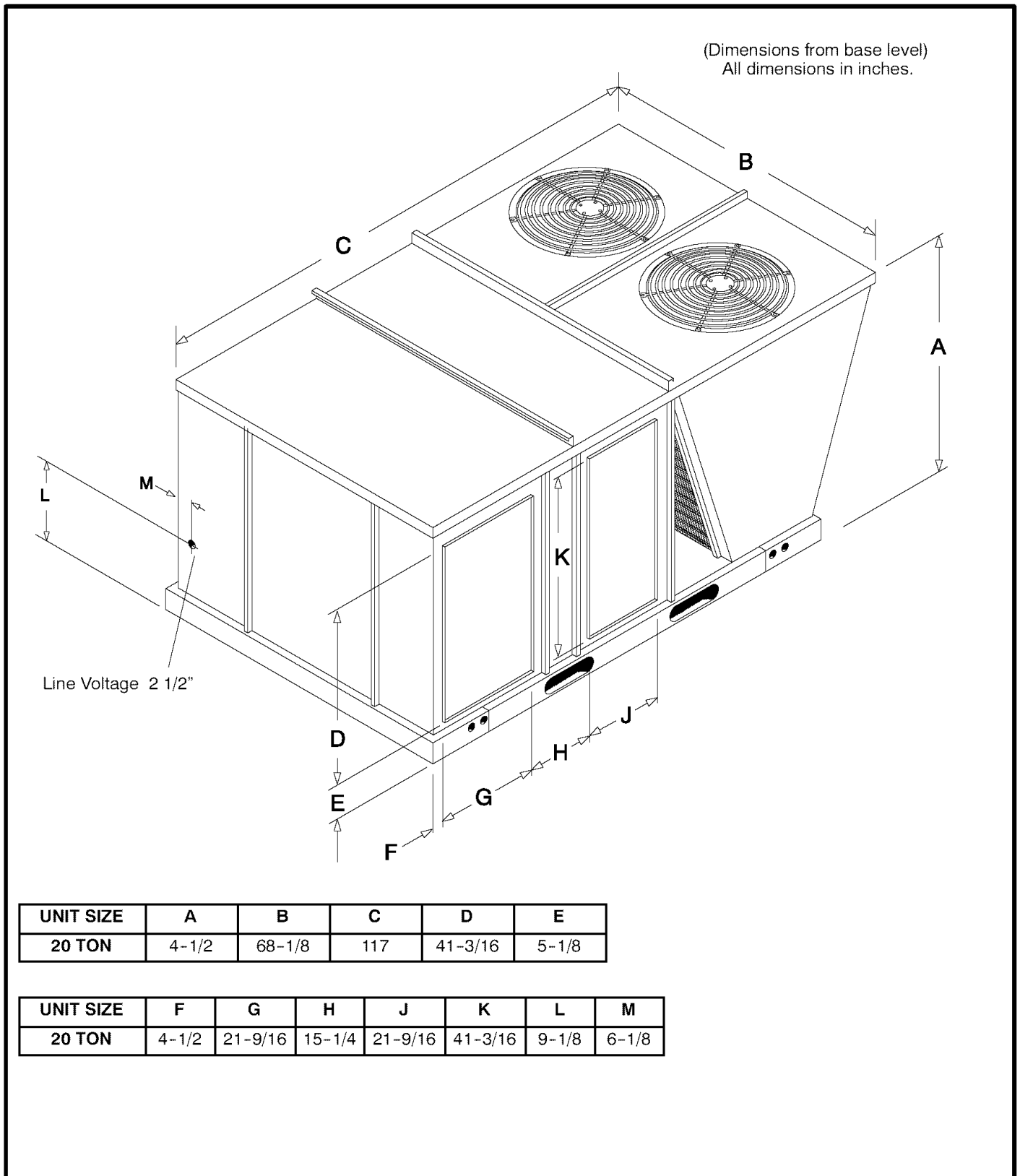

3. Safe Installation Requirements

WARNING

Installation or repairs made by unqualified persons can result in hazards to you and others. Installation must conform with local building codes or, in the absence of local codes, with National Electrical Code ANSI/NFPA 70-1990 or current edition. In Canada the National Standard CAN/CGA 1-B149.1 or current edition and CSA C.22.1 - Canadian Electrical Code Part 1 or current edition.

The information contained in this manual is intended for use by a qualified service technician familiar with safety procedures, equipped with the proper tools and test instruments.

Failure to carefully read and follow all instructions in this manual can result in furnace malfunction, property damage, personal injury and/or death.

- Installation **MUST** conform to the most current version of the following standards or a superseding standard.

In the United States:

- National Electrical Code ANSI/NFPA 70-1990

In Canada:

- CSA C.22.1 - Canadian Electrical Code Part 1.
- Seal supply and return air ducts.

NOTE: It is the personal responsibility and obligation of the customer to contact a qualified installer to ensure that the installation is adequate and conforms to governing codes and ordinances.

Figure 1

Access Panels

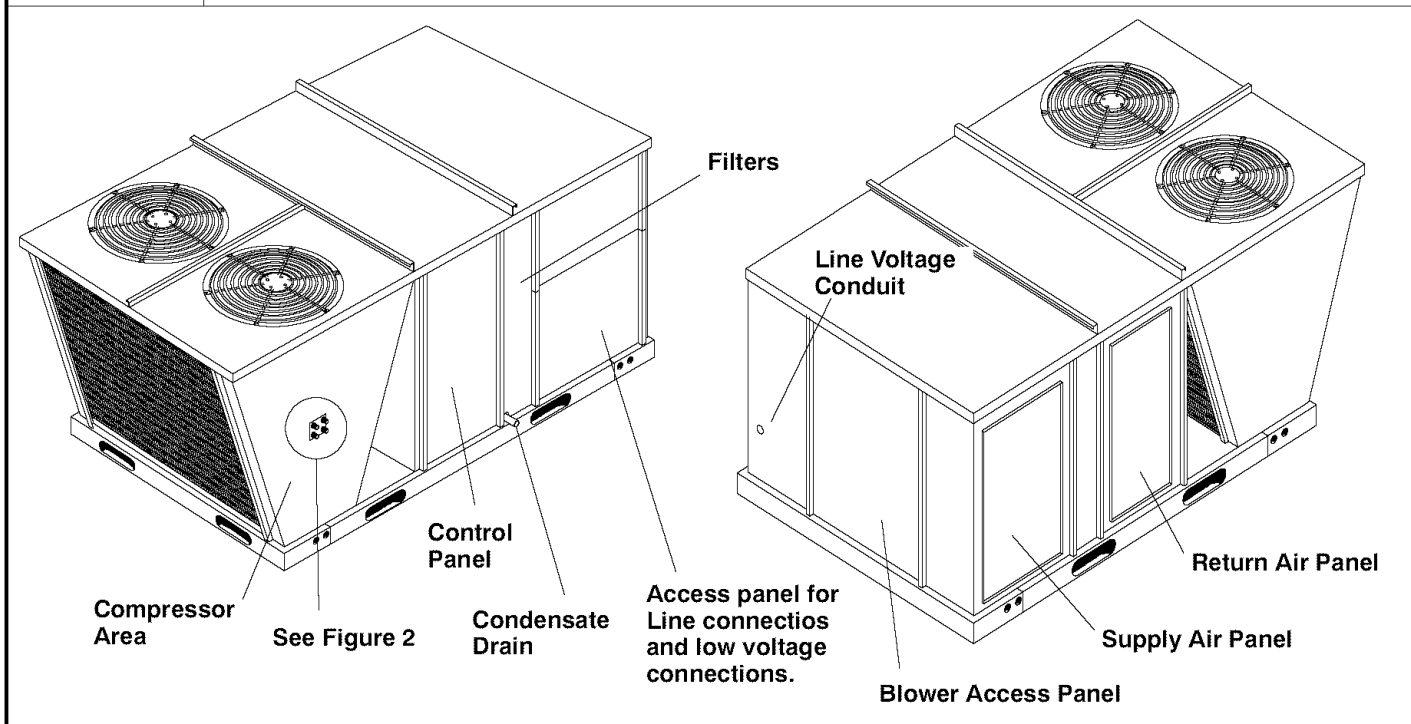

4. Location And Set-up

The unit is designed for outdoor installation **ONLY**. The unit may be installed on a level concrete mounting base (or other adequate platform) at ground level or on a flat rooftop with an adequate platform. If using as a downflow model, use a roof curb. Typical installations are shown in **Figures 3 and 4**.

Access Panels

CAUTION

Unit will **NOT** operate properly without all access panels in place. Access panels are shown in **Figure 1**.

Unit **MUST NOT** be moved unless all access panels are in place.

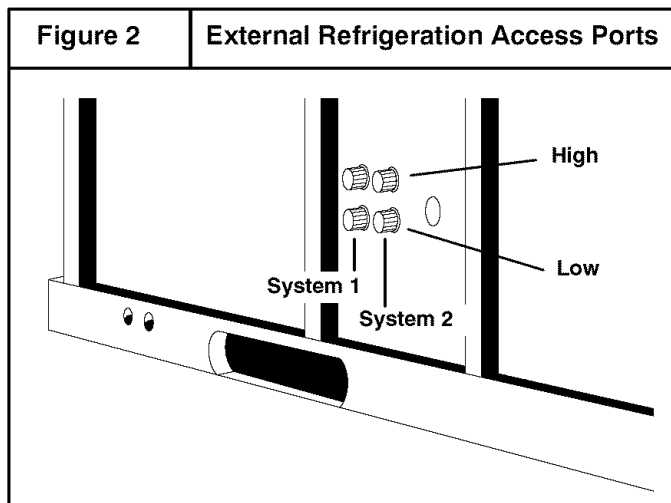

Clearances

The location **MUST** allow for minimum clearances and should not be adjacent to a patio or other area where the unit's operating sound level might be objectionable.

Minimum clearances, as specified in the following tables and in **Figure 3 and 4**, **MUST** be maintained to provide adequate fire protection, adequate combustion air, and room for service personnel. In addition, local codes **MUST** be observed.

Do **NOT** install the unit in a location that will permit discharged air from the condenser to recirculate to the condenser inlet.

CAUTION

Do **NOT** operate unit in a corrosive atmosphere containing chlorine, fluorine, or any other corrosive chemicals.

Minimum Clearances to non-Combustible Construction (Horizontal Flow)

- Duct Connection Side (no Economizer) . . . 30" (762mm)
- Duct Connection Side (with Economizer) . . . 48" (1220mm)
- Condenser Side 30" (762mm)
- Side Blower Access Panel Side 30" (762mm)
- Top of Unit 60" (1524mm)
- with 36" (914mm) maximum horizontal overhang from duct connection side

Minimum Clearances to non-Combustible Construction (Downflow)

- Duct Connection Side (no Economizer) . . . 30" (762mm)
- Duct Connection Side (with Economizer) . . . 52" (1321mm)
- Condenser Side 30" (762mm)
- Side Blower Access Panel Side 30" (762mm)
- Top of Unit 60" (1524mm)
- with 36" (914mm) maximum horizontal overhang from duct connection side

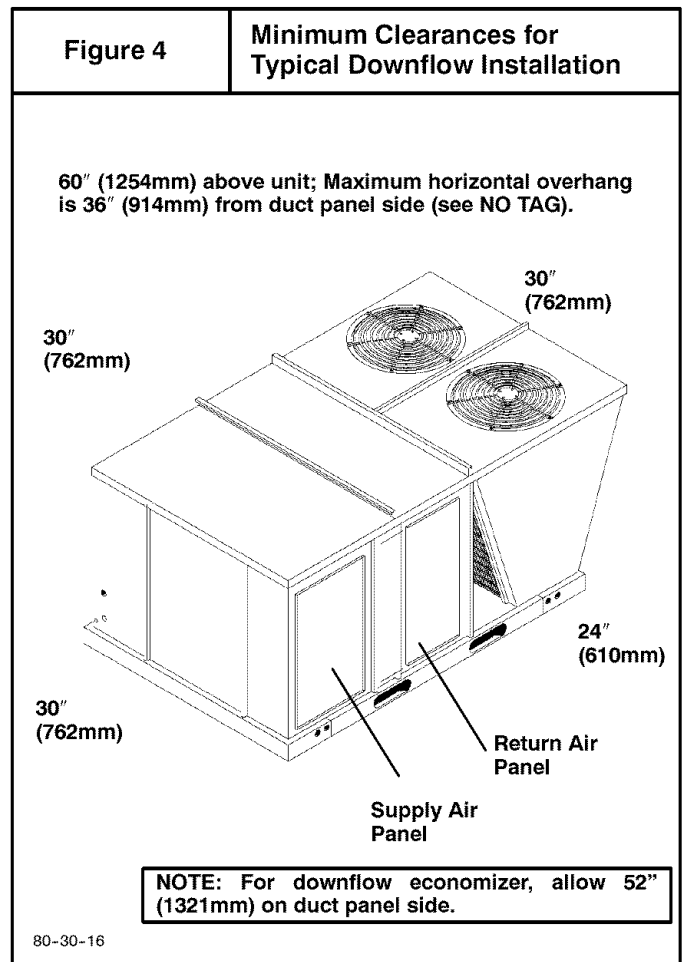
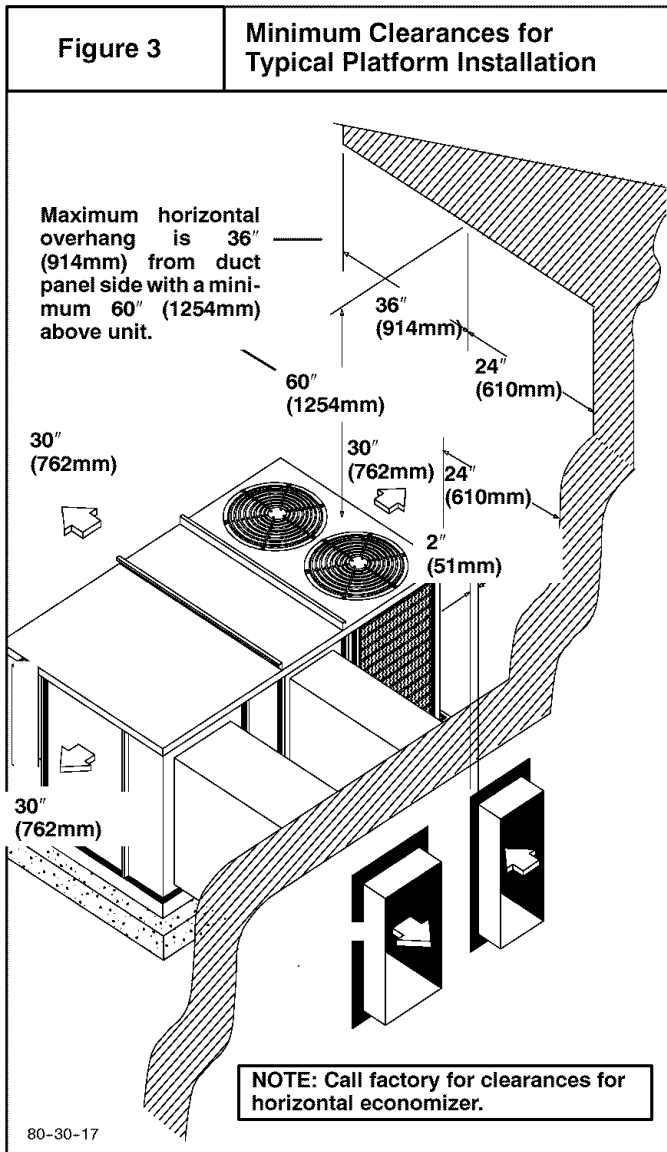

Installation

CAUTION

Unit will **NOT** operate properly unless it is installed level front to rear and side to side.

The slope **MUST NOT** be greater than $\frac{1}{8}$ " per foot (10mm per meter). For side to side leveling, the control box side **MUST** always be lower.

Ground Level Installation

Ground level platform requirements:

- The unit **MUST** be situated to provide safe access for servicing.
- Platform may be made of either concrete or pressure treated wood and **MUST** be level and strong enough to support unit weight.
- Position platform separate from building foundation.
- Install in well-drained area, with top surface of platform above grade level.
- Platform **MUST** be high enough to allow for proper condensate trap installation and drainage. See **Figure 5** and associated text for more information about condensate drainage.

Rooftop Installation

Rooftop platform requirements:

- The unit **MUST** be situated to provide safe access for servicing.
- The existing roof structure **MUST** be adequate to support the weight of the unit or the roof **MUST** be reinforced.

Check the weight of the unit in relation to the roof structure and local building codes or ordinances and reinforce roof structure if necessary. See the back cover of this manual for unit weights and corner weights.

- Support for the unit **MUST** be level and strong enough to carry unit weight. The support may consist of a platform or a combination of platform and roof beams or curb.

The platform may be constructed of pressure treated wood and may be covered with Class A, B or C roof covering.

- Platform **MUST** allow for proper condensate trap installation and drainage. See **Figure 5** and associated text for more information about condensate drainage.

- See *Hoisting* section below for hoisting instructions.

NOTE: Cardboard covers on horizontal supply and return duct openings **MUST** be removed before starting unit.

Hoisting

NOTE: All access panels **MUST** be secured in place before hoisting.

The unit should be hoisted with two lifting slings. Attach the slings to rigging shackles that have been hooked through holes in the base rail.

Two spreader bars **MUST** be placed on top of the unit to protect the unit from damage from the pressure exerted by the slings. Make sure that all equipment is adequate to handle the weight of the unit and that the slings will not allow the unit to shift.

Refer to the back cover of this manual for illustrated rigging instructions and weight chart.

Converting to Horizontal Operation

These units are shipped ready for downflow operation but are adaptable to horizontal use. To convert to horizontal operation, follow these steps:

1. Remove horizontal supply and return panels (see **Figure 1**).
2. Remove cardboard covers from downflow supply and return openings.
3. Install horizontal supply and return panels on downflow supply and return openings. Be sure flanges are down and insulation side is up. Install from inside of unit.

Condensate Drain

The condensate drain outlet is a $\frac{3}{4}$ " (19.1mm) threaded female PVC connection located at the bottom of the unit to the left of the electrical access panel (see **Figure 5**). Condensate drain outlet **MUST** be held with wrench when installing trap and drain line.

The circulating blower and the condenser fan create a negative pressure on the condensate drain line that will prevent the condensate from draining properly without a trap. To combat this negative pressure, a field supplied condensate trap that will allow a standing column of water of at least 2" (50.8mm) **MUST** be installed. Top of outlet

from trap **MUST** be at least 1" (25.4mm) below top of outlet from unit. **Install the trap as near to the unit as possible for proper drainage.**

A $\frac{3}{4}$ " (19.1mm) drain line **MUST** be installed if required by local codes or if location of unit requires it. Run the drain line to an open drain or other suitable disposal point.

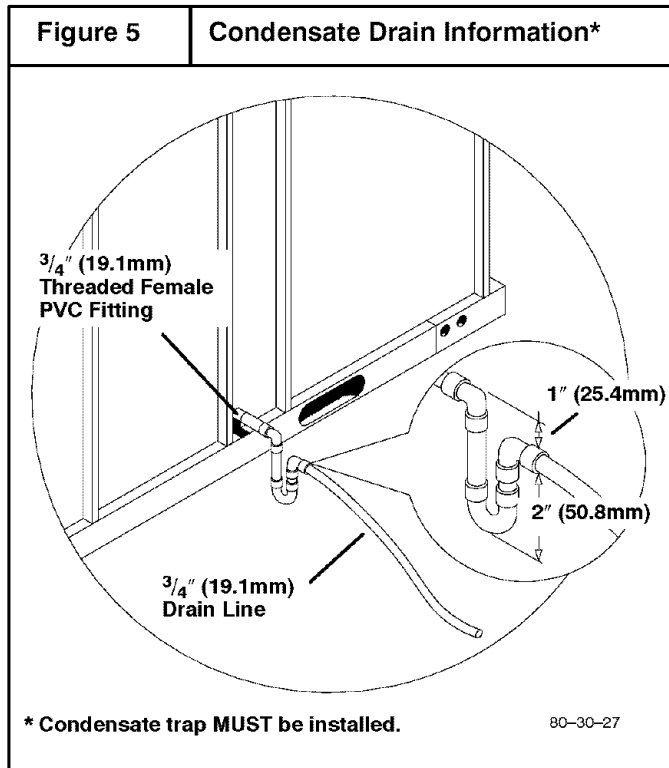

5. Electrical Wiring

WARNING

Electrical shock hazard.

Shut off electric power at unit disconnect or service panel before making any electrical connections.

Unit **MUST** be grounded to electrical service panel.

Failure to follow this warning can result in property damage, personal injury, and/or death.

NOTE: All electrical work **MUST** conform with the requirements of local codes and ordinances and in the United States the National Electrical Code ANSI/NFPA70-1990 (or current edition) and in Canada CSA C.22.1 - Canadian Electrical Code Part 1 (or current edition). Provide line voltage power supply from a separate protected circuit with a disconnect switch (when required) located within sight of the unit. Supply voltage, amperage, wire, fuse and disconnect switch sizes **MUST** conform with specifications on the unit rating plate.

Wiring **MUST** be protected from possible mechanical damage and **MUST NOT** interfere with removal of access panels, filters, etc.

All exposed wiring or connections **MUST** be made with weatherproof cable or wire unless installed in conduit.

Connections for line voltage are made in the lower blower section section. Low voltage connections are made at the terminal board in the blower section on the right hand side (see **Figure 7**).

For access to high and low voltage connections, remove the lower blower access panel. (see **Figure 1**).

Line Voltage Wiring

Line voltage wires enter the unit through the double knockout on the end of the unit next to the blower. (see **Figure 7**). Do **NOT** complete line voltage connections until unit is permanently grounded. All line voltage connections and the ground connection **MUST** be made with copper wire.

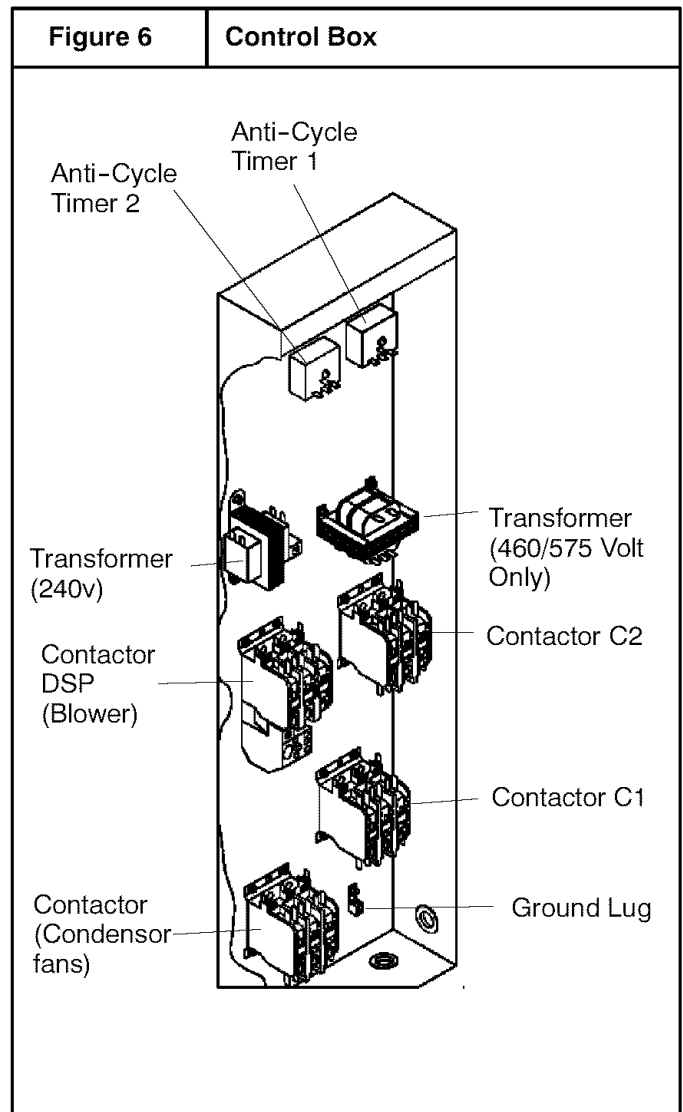

Line Connections

Complete the line service connections to the terminal block in the blower section. Refer to applicable wiring diagram. Check all screw terminals to ensure they are tight.

Converting 230V Units to 208V

To convert 230V units to 208V:

1. Turn electric power **OFF**.
2. Remove control box access panel and open control box. Locate the 24V control transformer.
3. Remove wires from the terminal labeled '240V' on the 24V control transformer and reconnect them to the 208V terminal of the 24V control transformer.
4. Close control box and replace control box access panel.

Field Installed Equipment

All wiring done in the field between the unit and other devices, or between separate devices that are field installed and located, **MUST** not exceed the temperature limitations for type T wire and **MUST** be installed according to the manufacturer's instructions for the devices.

Low Voltage Wiring

Low voltage wiring connections for the thermostat are made at the 24V terminal board which is located in the lower blower section. For access, remove the lower blower access panel. Refer to the wiring diagram and the instructions included with the thermostat.

Low Voltage Wiring With Economizer Option

The economizer electrical harness taps into **Y1** and **Y2** on the low voltage terminal board. Low voltage wires from the thermostat are connected to **Y1** and **Y2** with or without an economizer.

Thermostat

The thermostat **MUST** be a field supplied 2 stage cooling. A 2 stage cooling - 2 stage heating thermostat will be required if optional electric heat is used. **The subbase must have W & G tied together.**

The location of the thermostat has an important effect on the operation of the unit. **FOLLOW THE INSTRUCTIONS INCLUDED WITH THE THERMOSTAT FOR CORRECT LOCATION, MOUNTING AND WIRING.**

1. Run the thermostat wire into the unit through the port located at the end of the unit at the right side of the blower access panel (see **Figure 7**).
2. Run wire through strain relief to low voltage terminal board.
3. Tighten strain relief.

Figure 7

Wiring Thermostat to Unit

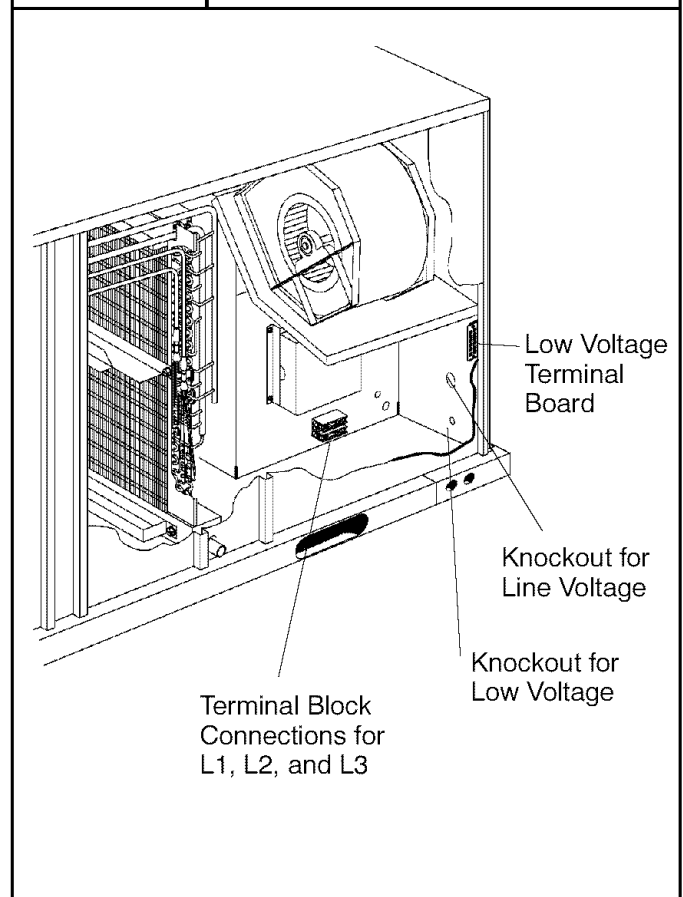

Heat Anticipator

Set the thermostat heat anticipator according to the instructions included with the electric strip heaters.

Final Check

Make a final wiring check to be sure system is correctly wired. Inspect field installed wiring and the routing to ensure that rubbing or chafing due to vibration will not occur.

6. Air Distribution System

Ductwork

NOTE: The total heat loss from the structure as expressed in total Btu/hr **MUST** be calculated by manufacturer's method or in accordance with "A.S.H.R.A.E. Guide" or "Manual N - Load Calculations" published by the Air Conditioning Contractors of America or in Canada H.R.A.I. "Manual N". The total heat loss calculated should be equal to or less than the heating capacity.

Ductwork, supply registers, and return air grilles **MUST** be designed and sized to handle the greater of the units heating or cooling air volume requirements. If the unit is connected to an existing system, the ductwork **MUST** be checked to make sure it is adequate. Extra runs or larger duct sizes may have to be installed. **Use only non-combustible type insulation on supply plenum or supply ductwork within 6 feet of unit.**

Maximum recommended velocity in trunk ducts is 1000 feet per minute (5.08 m/s). Velocity in branches should not exceed 800 feet per minute (4.06 m/s).

Ductwork installed outdoors should have a minimum of 2" (50.8mm) of fiberglass insulation and a weatherproof vapor barrier. It should also be protected against damage. Caulk and flashing, or other means adequate to provide a permanent weather seal should be used.

Ductwork installed in attics or other areas exposed to outside temperatures should be installed with a minimum of 2" (50.8mm) fiberglass insulation and have an indoor type vapor barrier.

Ductwork Connections

The use of flexible, **non-combustible** connectors between main trunk ducts and supply and return air plenums is recommended to minimize vibration transmission.

NOTE: Connect supply and return air plenums to unit in a manner that will allow the top of the unit to be removed without removing plenums. Plenums **MUST** be individually sealed to unit casing.

Filters

CAUTION

Do NOT operate the unit without all filters in place.

All air **MUST** pass through a filter before entering the unit. Electronic air cleaner, optional filter racks, or other accessible filter arrangements **MUST** be installed in the return air ductwork.

NOTE: If the unit has an economizer or any other type of outdoor air damper, disposable filters **MUST** be used in the internal filter racks.

For replacement filter sizes and instructions, see *Air Filters* on **Page 21**.

Circulating Blower

Determining Blower Speed

1. From the system design, determine the external static pressure (ESP) for the supply ducts, return ducts and registers, diffusers, grilles, dampers, heaters and special filters (if any).
2. If unit is to be set up in cooling mode, add .08" W.C. (20 Pa) for wet coil operation to the total ESP determined in Step 1.
3. For data on static additions due to installation of an economizer or manual air dampers, see **Notes** below the unit's airflow chart.
4. From the system design, determine the desired airflow in CFM (L/s). See **Figure 8** for CFM to L/s conversion table.
5. To determine the blower speed necessary to obtain the desired CFM (L/s), see the Circulating Blower Performance Data graph for the unit located on the pages that immediately follow.
6. Locate the total ESP value on the graph and draw a horizontal line across the graph.
7. Locate the correct CFM (L/s) value on the graph and draw a vertical line.
8. Mark the intersection of the horizontal and vertical lines. From the RPM curves, determine the blower RPM's needed to obtain the desired CFM (L/s).
9. Compare required RPM to unit's factory setting for blower RPM (see Blower Performance Tables). If it is different from the RPM your installation requires, the blower speed will need to be changed.
10. Below each unit's Circulating Blower Performance Data table is a table that shows how many turns open the adjustable blower motor pulley needs to be to obtain the required RPM.
11. To change the blower speed, see **Figure 9**.

Figure 8		Metric Conversions: Cubic Feet per Minute (CFM) to Liters per Second (L/s); Inches of Water Column (In. W.C.) to Pascals (Pa)													
CFM	L/s	CFM	L/s	CFM	L/s	In. W.C.	Pa	In. W.C.	Pa	In. W.C.	Pa	In. W.C.	Pa	In. W.C.	Pa
50	24	2550	1203	5050	2383	0.01	2	0.51	127	1.01	251	1.51	376	2.01	501
100	47	2600	1227	5100	2407	0.02	5	0.52	130	1.02	254	1.52	379	2.02	503
150	71	2650	1251	5150	2430	0.03	7	0.53	132	1.03	257	1.53	381	2.03	506
200	94	2700	1274	5200	2454	0.04	10	0.54	135	1.04	259	1.54	384	2.04	508
250	118	2750	1298	5250	2477	0.05	12	0.55	137	1.05	262	1.55	386	2.05	511
300	142	2800	1321	5300	2501	0.06	15	0.56	139	1.06	264	1.56	389	2.06	513
350	165	2850	1345	5350	2525	0.07	17	0.57	142	1.07	267	1.57	391	2.07	516
400	189	2900	1369	5400	2548	0.08	20	0.58	144	1.08	269	1.58	394	2.08	518
450	212	2950	1392	5450	2572	0.09	22	0.59	147	1.09	271	1.59	396	2.09	521
500	236	3000	1416	5500	2595	0.10	25	0.60	149	1.10	274	1.60	399	2.10	523
550	260	3050	1439	5550	2619	0.11	27	0.61	152	1.11	276	1.61	401	2.11	526
600	283	3100	1463	5600	2643	0.12	30	0.62	154	1.12	279	1.62	404	2.12	528
650	307	3150	1486	5650	2666	0.13	32	0.63	157	1.13	281	1.63	406	2.13	531
700	330	3200	1510	5700	2690	0.14	35	0.64	159	1.14	284	1.64	408	2.14	533
750	354	3250	1534	5750	2713	0.15	37	0.65	162	1.15	286	1.65	411	2.15	536
800	378	3300	1557	5800	2737	0.16	40	0.66	164	1.16	289	1.66	413	2.16	538
850	401	3350	1581	5850	2761	0.17	42	0.67	167	1.17	291	1.67	416	2.17	541
900	425	3400	1604	5900	2784	0.18	45	0.68	169	1.18	294	1.68	418	2.18	543
950	448	3450	1628	5950	2808	0.19	47	0.69	172	1.19	296	1.69	421	2.19	545
1000	472	3500	1652	6000	2831	0.20	50	0.70	174	1.20	299	1.70	423	2.20	548
1050	495	3550	1675	6050	2855	0.21	52	0.71	177	1.21	301	1.71	426	2.21	550
1100	519	3600	1699	6100	2879	0.22	55	0.72	179	1.22	304	1.72	428	2.22	553
1150	543	3650	1722	6150	2902	0.23	57	0.73	182	1.23	306	1.73	431	2.23	555
1200	566	3700	1746	6200	2926	0.24	60	0.74	184	1.24	309	1.74	433	2.24	558
1250	590	3750	1770	6250	2949	0.25	62	0.75	187	1.25	311	1.75	436	2.25	560
1300	613	3800	1793	6300	2973	0.26	65	0.76	189	1.26	314	1.76	438	2.26	563
1350	637	3850	1817	6350	2997	0.27	67	0.77	192	1.27	316	1.77	441	2.27	565
1400	661	3900	1840	6400	3020	0.28	70	0.78	194	1.28	319	1.78	443	2.28	568
1450	684	3950	1864	6450	3044	0.29	72	0.79	197	1.29	321	1.79	446	2.29	570
1500	708	4000	1888	6500	3067	0.30	75	0.80	199	1.30	324	1.80	448	2.30	573
1550	731	4050	1911	6550	3091	0.31	77	0.81	202	1.31	326	1.81	451	2.31	575
1600	755	4100	1935	6600	3115	0.32	80	0.82	204	1.32	329	1.82	453	2.32	578
1650	779	4150	1958	6650	3138	0.33	82	0.83	207	1.33	331	1.83	456	2.33	580
1700	802	4200	1982	6700	3162	0.34	85	0.84	209	1.34	334	1.84	458	2.34	583
1750	826	4250	2006	6750	3185	0.35	87	0.85	212	1.35	336	1.85	461	2.35	585
1800	849	4300	2029	6800	3209	0.36	90	0.86	214	1.36	339	1.86	463	2.36	588
1850	873	4350	2053	6850	3233	0.37	92	0.87	217	1.37	341	1.87	466	2.37	590
1900	897	4400	2076	6900	3256	0.38	95	0.88	219	1.38	344	1.88	468	2.38	593
1950	920	4450	2100	6950	3280	0.39	97	0.89	222	1.39	346	1.89	471	2.39	595
2000	944	4500	2124	7000	3303	0.40	100	0.90	224	1.40	349	1.90	473	2.40	598
2050	967	4550	2147	7050	3327	0.41	102	0.91	227	1.41	351	1.91	476	2.41	600
2100	991	4600	2171	7100	3350	0.42	105	0.92	229	1.42	354	1.92	478	2.42	603
2150	1015	4650	2194	7150	3374	0.43	107	0.93	232	1.43	356	1.93	481	2.43	605
2200	1038	4700	2218	7200	3398	0.44	110	0.94	234	1.44	359	1.94	483	2.44	608
2250	1062	4750	2242	7250	3421	0.45	112	0.95	237	1.45	361	1.95	486	2.45	610
2300	1085	4800	2265	7300	3445	0.46	115	0.96	239	1.46	364	1.96	488	2.46	613
2350	1109	4850	2289	7350	3468	0.47	117	0.97	242	1.47	366	1.97	491	2.47	615
2400	1133	4900	2312	7400	3492	0.48	120	0.98	244	1.48	369	1.98	493	2.48	618
2450	1156	4950	2336	7450	3516	0.49	122	0.99	247	1.49	371	1.99	496	2.49	620
2500	1180	5000	2360	7500	3539	0.50	125	1.00	249	1.50	374	2.00	498	2.50	623

Figure 9

Circulating 20 Ton Blower Performance Data

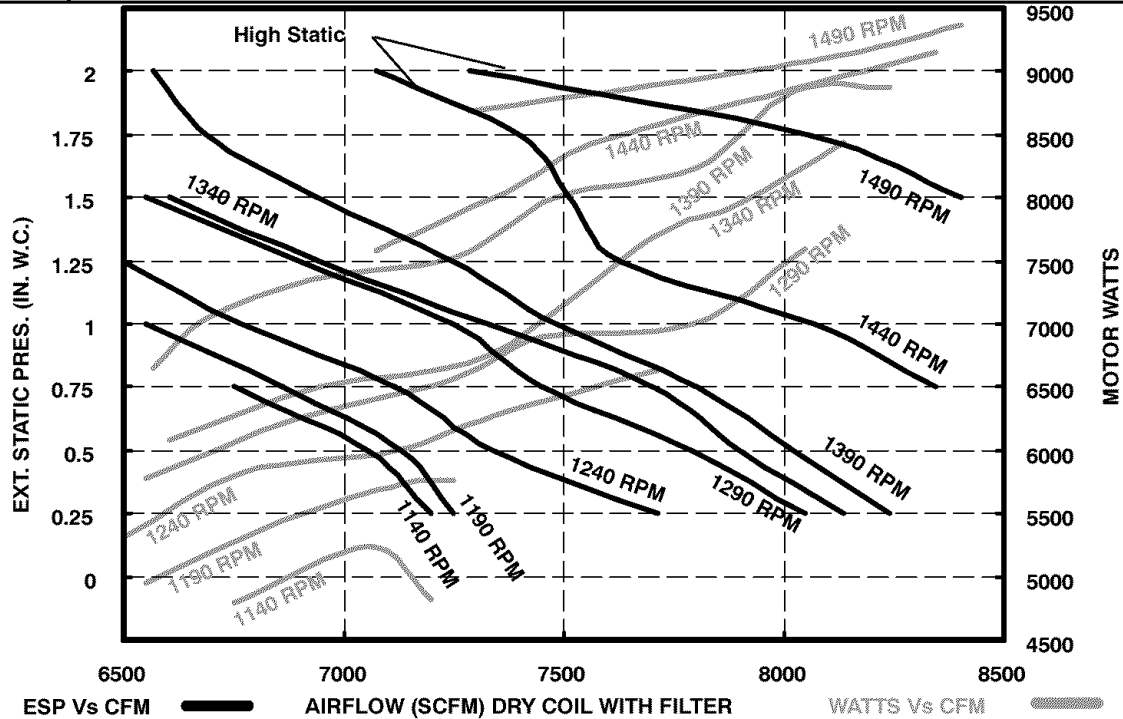

NOTES: 1) Maximum motor Watts is 10,100 Watts. 2) Maximum blower wheel speed is 1800 RPM. 3) Contact factory for applications requiring operation outside standard cooling operating range. 4) Airflow data based on dry coil with filters. For wet coil add 0.08 inches to ESP. Downflow has the same ESP as horizontal flow. 5) Add 0.20 inches to ESP for horizontal economizer, downflow economizer, or manual air dampers. 6) Pulley turns refers to turns out. In other words, 0 turns is a narrower sheave than 5 turns. 7) Blower speed MUST be set to give the correct air temperature rise through the unit as marked on the Rating Plate.

CFM	EXTERNAL STATIC PRESSURE IN INCHES WATER COLUMN (PASCALS)																
	.25 (62)		.50 (124)		.75 (186)		1.0 (249)		1.25 (311)		1.50 (373)		1.75 (435)		2.0 (497)		
	RPM	W	RPM	W	RPM	W	RPM	W	RPM	W	RPM	W	RPM	W	RPM	W	
6750														1390	7100	1410	7300
7000					1220	5800	1265	6250	1350	6650	1380	7200	1410	7400	1430	7600	
7250	1190	5760	1220	5920	1260	6300	1290	6550	1390	7500	1410	7700	1425	7750	1480	8600	
7500	1220	6150	1255	6500	1300	6950	1390	8010	1420	8250	1440	8400	1460	8650			
7750	1250	6750	1280	6850	1360	8000	1420	8450	1450	8700	1460	9750	1475	8800			
8000	1280	7300	1380	8800	1420	8800	1433	8870	1455	8950	1470	9000	1480	9050			
8250	1400	8890	1420	9150	1432	9200	1455	9250	1470	9270	1480	9300					

High Static Data

NOTE: DO NOT EXCEED 25.3 AMPS ON BLOWER MOTOR AT ANY POINT.

PULLEY TURNS OPEN		0	1	2	3	4	5
FAN	STD PULLEY	1390	1340	1295	1245	1195	1140
RPM	HIGH STATIC PULLEY	1540	1495	1445	1390	1345	1295

AIRFLOW CORRECTION FACTORS - 20 TON					
CFM - ACTUAL	5760	6480	7200	7920	8640
TOTAL MBH	0.95	0.98	1.00	1.02	1.05
SENSIBLE MBH	0.90	0.95	1.00	1.05	1.10
POWER KW	0.98	0.99	1.00	1.01	1.02

FACTORY SETTING TURNS OPEN	
10 HP STD PULLEY	4
10 HP HIGH STATIC PULLEY	See NOTE

NOTE: High static pulleys are field installed and MUST be adjusted by the installing technician.

NOTES: 1) Multiply correction factor times gross performance data. 2) Resulting sensible capacity cannot exceed total capacity.

PART NUMBERS FOR APPROVED HIGH STATIC CONVERSIONS				
Unit	Motor	Motor Pulley	Blower Pulley	Belt
20 Ton	No Change	1082350(IVP65)	No Change	No Change

7. Adjustable Belt Drive Blower

WARNING

Personal injury hazard.

Use extreme care during the following procedures and obey Safety Information.

Failure to do so may result in personal injury.

The following safety rules **MUST** always be followed when working near belt drive.

Always Turn The Power Off

Turn electric power to the unit **OFF** before you begin working on it.

Always Wear Protective Clothing

NEVER wear loose or bulky clothes, such as neckties, exposed shirttails, loose sleeves, or lab coats around belt drives. Wear gloves while inspecting sheaves to avoid nicks, burrs, or sharply worn pulley edges.

The blower speed is changed by adjusting the variable speed pulley mounted on the blower motor.

If the blower speed needed is different than the speed of the blower as shipped, follow the steps below to change the blower speed. Before changing the blower speed, read the above safety rules first.

1. Turn electric power **OFF**.
2. Remove the side blower access panel (see **Figure 1**).

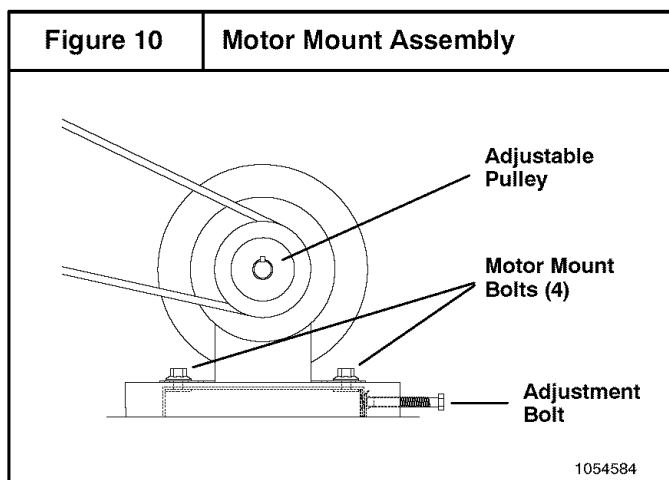

3. Loosen the four motor mount bolts.
4. Turn the motor adjustment bolt counterclockwise until the belt is slack enough to come off easily (see **Figure 10**).
5. Remove the belt. Do **NOT** attempt to pry off belt with tools or fingers.
6. Loosen set screw(s) on the outer half of the adjustable pulley.

The unit has one of two different types of adjustable pulleys (see **Figure 11** or **12**).

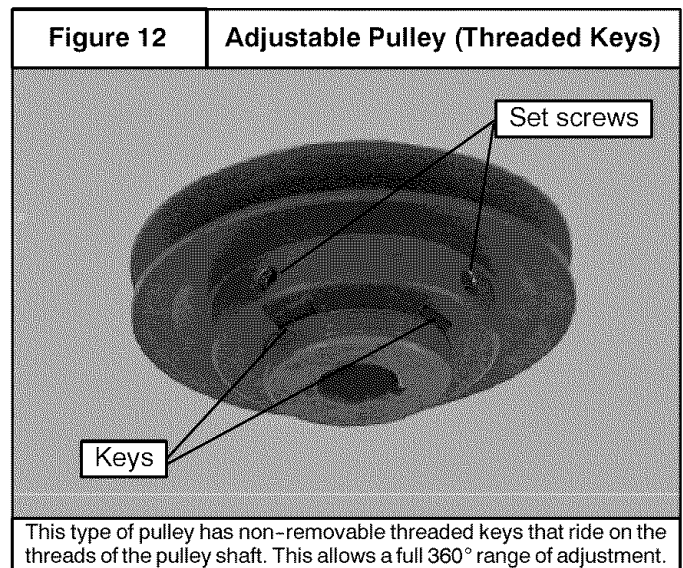
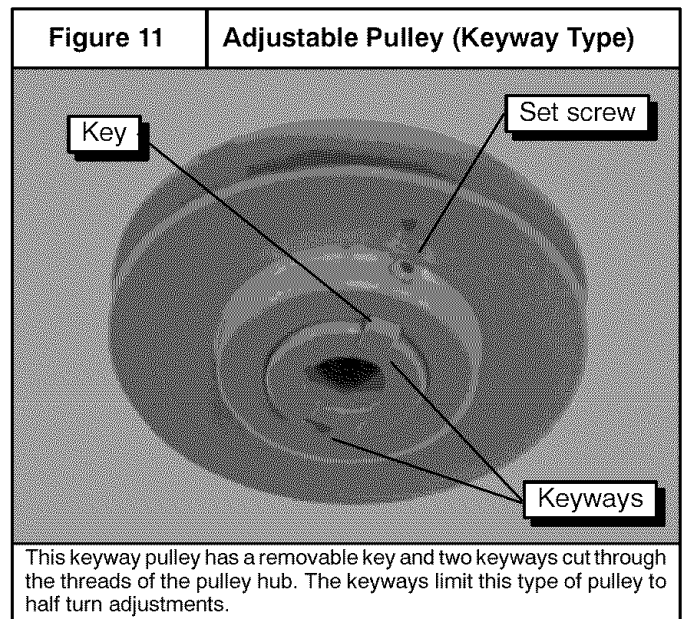

7. Remove key if unit has a keyway type pulley.

8. To set the blower for a desired CFM (L/s), first turn the outer half of the adjustable pulley clockwise until it meets the inner half of the pulley.
9. Turn the outer half of the adjustable pulley counterclockwise the correct number of turns to obtain the desired CFM (L/s).

NOTE: To increase the blower speed, turn the outer half of the adjustable pulley clockwise. To decrease the blower speed, turn the outer half of the adjustable pulley counterclockwise.

10. Replace key if unit has keyway type pulley.
11. Tighten set screw(s).
12. Put on belt.

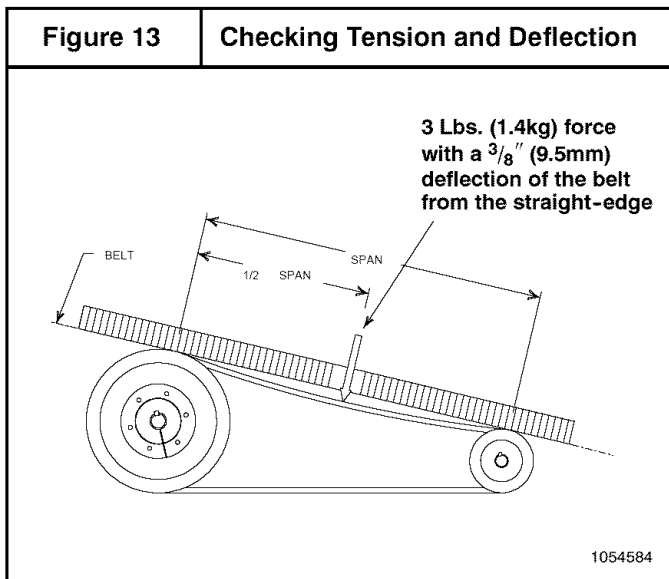
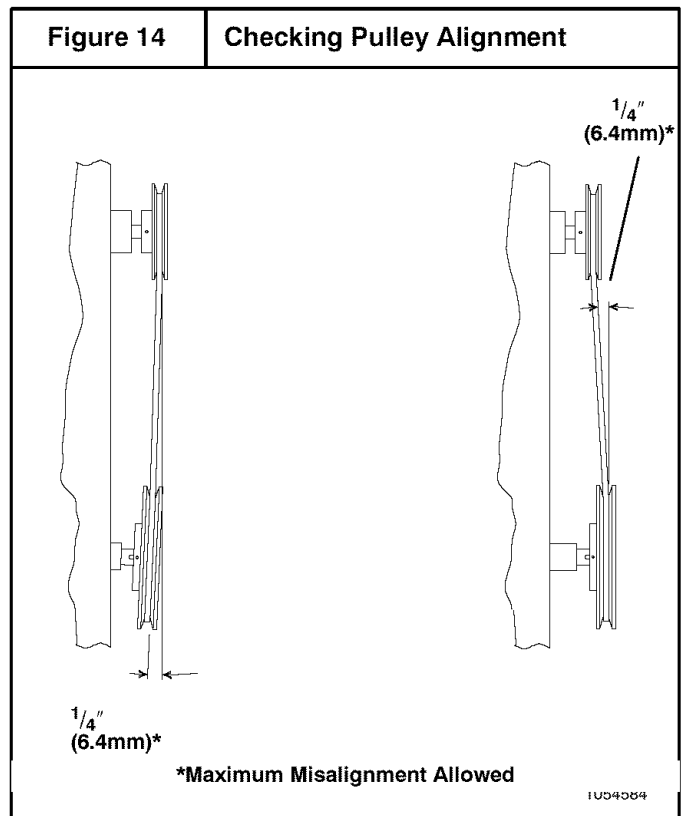

13. Turn motor adjustment bolt clockwise until the belt has enough tension at the proper deflection. Use one of the commercially available belt tension gauges to set the correct tension at the proper deflection (see **Figure 13**).

14. Use a straight-edge (angle iron, straight piece of board or anything with a good straight surface or edge) to check the alignment of the blower pulley with blower motor pulley (see **Figure 14**).

It may be necessary to back the tension off the belt temporarily and tighten one of the motor mount bolts before it is possible to adjust the angle of the blower motor.

15. Tighten all four blower motor mount bolts.
16. Ensure that all bolts, nuts and screws are tightened and ensure that all tools, gloves, etc. are removed from unit.
17. Replace side blower access panel before Start-up.
18. During Start-up, listen for any unusual noises or vibrations.
19. Shut down the unit after it runs for a while and check the bearings and motor. If they feel hot, the belt tension may be too tight, bearings may be misaligned or not lubricated correctly, etc.
20. It is a good idea to retension a new belt after a run-in period of about 24 hours. A run-in period of overnight or during a lunch break is better than no run-in period at all.

8. Economizer Accessory

The purpose of an economizer is to:

- Provide cool outside air to the conditioned space during the cooling cycle to minimize the use of the compressors.
- Bring outside air into the conditioned space to meet minimum ventilation air requirements whenever the circulation blower is running.

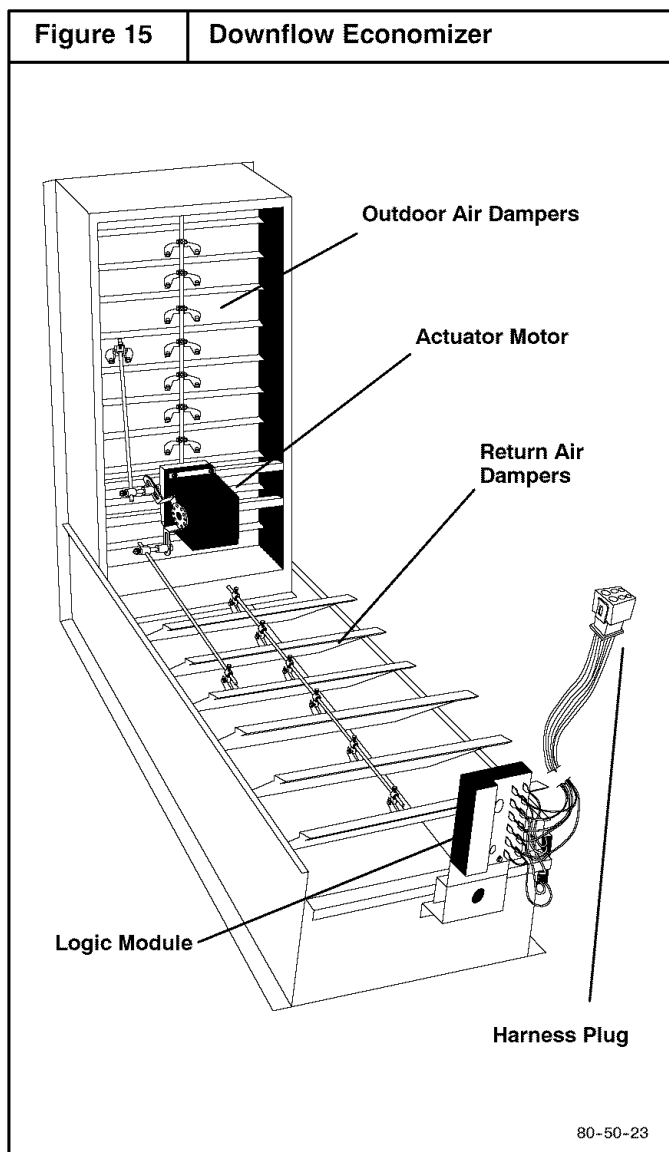

Static Additions

Static numbers from the following table must be added to the unit's total static if a horizontal economizer, vertical economizer, or manual air damper is used.

20 ton 0.20" W.C.

Theory of Operation

The economizer has two sets of dampers that are mechanically linked together. The outdoor air dampers regulate the intake of outside air and the return air dampers regulate the flow of return air (see **Figure 15**). When the outdoor air dampers modulate open, the linkage causes the return air dampers to modulate closed.

The economizer is controlled by a logic module which field connects to the unit controls through a harness plug. The logic module also controls the compressor staging based on the thermostat input.

The minimum opening position of the outdoor air dampers is field adjustable. It is set on the logic module of modulating economizers or on the actuator motor of three-position economizers.

The enthalpy sensor is factory installed on the outdoor air dampers. The enthalpy change-over point is adjustable on the logic module.

A mixed air sensor is field installed in the blower inlet. The mixed air sensor keeps the mixed air above 56°F (13.3°C). See the economizer installation instructions for the location of the air sensor.

A positive pressure is created in the building when the outdoor air dampers open and the return dampers close. This pressure must be vented or the air will not circulate properly. This is the function of the barometric relief dampers. A positive pressure forces the passive exhaust dampers to swing open.

The outdoor air dampers open to the minimum position for outside air whenever the circulation blower is ON.

When the thermostat is in the FAN AUTO position, the outdoor air dampers will close completely whenever heating or cooling is not called for.

Sequence of Operation

NOTE: For correct low voltage wiring when economizer option is being used, see **Low Voltage Wiring With Economizer Option** on **Page 10**.

When the thermostat is in the FAN ON position:

1. The outdoor air dampers will open to the minimum position for outdoor air.
2. On a call for cooling, if the economizer's outdoor enthalpy sensor determines that the outside air conditions are correct, the outdoor air dampers will modulate open and the return air dampers will modulate closed.
3. On demand for cooling the thermostat completes Circuit 1 between thermostat terminals **R** and **G** and **Y1** for first stage cooling . Second stage cooling begins when the thermostat completes Circuit 2 between thermostat terminals **R** and **G** and **Y2**.

Both circuits have a low voltage safety circuit consisting of a high pressure switch, a low pressure switch and an anti-cycle delay timer.

4. When Circuit 1 is made, the economizer logic module is energized at low voltage terminal board terminal **Y1**. If the outside temperature is cool enough, the outdoor air dampers will open and the return air dampers will close.

5. The mixed air sensor at the blower inlet modulates the economizer dampers to prevent the mixed air from falling below 56°F (13.3°C). The mixed air sensor modulates the outdoor air dampers between the full open and minimum outdoor air positions.

If the conditioned space is not being maintained at the selected temperature, the thermostat will make Circuit 2 and call for second stage cooling by energizing the economizer logic module at low voltage terminal board terminal **Y2**. This energizes the Y1 anti-cycle delay and contactor C1 which energizes the condenser fan(s) and compressor 1 for cooling to assist the economizer.

NOTE: Contactor C2 cannot be energized to operate compressor 2 while the economizer is still energized since Circuit 1 is activating the economizer and Circuit 2 is activating compressor 1.

6. If the thermostat is still calling for cooling and the outside air warms to above the setting for economizer operation:
 - a. The economizer dampers will close to the minimum position for outside air and remain there.
 - b. Contactor C1 will remain energized and compressor 1 will continue to run.
 - c. Contactor C2 will close and compressor 2 will start.

9. Start-up Procedure

WARNING

Electrical shock, fire and/or explosion hazard.

Use extreme care during all of the following checks and procedures.

Make sure Electric Power and is turned OFF as instructed in appropriate steps.

Failure to follow this warning can result in property damage, personal injury, and/or death.

NOTE: For correct low voltage wiring when economizer option is being used, see **Low Voltage Wiring With Economizer Option** on Page 10.

Check the unit's operation as outlined in the following instructions.

Blower and Phasing Check

1. Shut **OFF** electric power at unit disconnect.
2. Check to see that clean, properly sized air filters are installed.
3. Check to see that everything inside the unit is clear and ready to operate safely. Ensure that there are no objects in, on or around the motor, belt or blower wheel.
4. Set thermostat Heat-Cool selector to **OFF**.
5. Set thermostat fan switch to **AUTO**.

WARNING

Moving parts hazard.

Do **NOT** put hands or any other object in, on or around the motor, belt or blower wheel. Ensure that there are no objects in, on or around the motor, belt or blower wheel before turning electric power on.

Failure to follow this warning can result in property damage, personal injury, and/or death.

6. Turn **ON** electric power. Nothing should start running. If any unusual arcing, odors or noises are encountered, shut **OFF** electric power immediately and check for wiring errors.

NOTE: The circulation blower motor and compressor(s) are three phase and are factory synchronized for proper rotation. *Even if the circulation blower motor comes on and air seems to be circulating, it is possible that the blower motor rotation is incorrect due to improper phasing.* The scroll compressor(s) (if equipped) will run backwards under this condition and be damaged. It is therefore necessary to check for proper rotation.

CAUTION

Do NOT operate the unit with the compressor(s) running until proper blower rotation has been confirmed by running the following test.

7. Set thermostat fan switch to **ON**. The circulating air blower should come **ON**.
8. Shut **OFF** electric power at unit disconnect and visually observe the direction of the blower rotation as it slows down. Do **NOT** put hands or any other object in, on or around the belt, motor or blower wheel. If blower wheel rotation is the same as the directional arrow on the blower housing, proceed to the next step.

CAUTION

If blower rotation is incorrect, shut electric power OFF at unit disconnect and reverse any two supply wires at field connections ONLY. Do NOT reverse the blower and/or compressor leads or rewire any internal wiring. After rewiring is done, repeat blower rotation check to ensure that blower rotation is now correct.

9. If blower rotation is correct, reset thermostat fan switch to **AUTO**. The circulating air blower should go **OFF**. Nothing should be running.
10. Shut **OFF** electric power at unit disconnect.

Cooling Checks

The compressors have a five minute anti-cycle delay that is activated whenever the compressors turn off. For instance, if the unit is manually shut off when the compressors are running and the unit is turned back on two minutes later, it will be an additional three minutes before the compressors will restart.

NOTE: For correct low voltage wiring when economizer option is being used, see **Low Voltage Wiring With Economizer Option on page 10.**

CAUTION

Do NOT operate the unit with the compressor(s) running until proper blower rotation has been confirmed during the Blower and Phasing Check in the previous section. If the phasing is incorrect, the scroll compressor(s) (if equipped) will run backwards and they will be damaged.

1. Be sure that electric power is **OFF**.
2. To check cooling Stage 1, place jumper wires across low voltage terminal board terminals **R** to **G**, **R** to **Y1**.
3. Turn electric power **ON**. Check to see that the following occurs:
 - a. Compressor 1 - **ON**
 - b. Condenser fan motor(s) - **ON**

- c. Circulation air blower - **ON** with correct rotation and adequate airflow from ductwork.
4. Shut **OFF** electric power at unit disconnect.
5. To check cooling Stage 2, remove jumper wires from **Y1** and place it on **Y2**.

NOTE: Allow 5 minutes between Steps 4 and 6.

6. Turn **ON** electric power. Check to see that the following occurs:
 - a. Compressors 1 & 2 - **ON**
 - b. Condenser fan motor(s) - **ON**
 - c. Circulation air blower - **ON**

NOTE: If **Y2** only is jumpered, condenser fans will not come on.

7. Shut **OFF** electric power at unit disconnect. Begin timing the five minutes for the anti-cycle delay.
8. Remove jumpers from low voltage terminal board.
9. Set Thermostat to COOL and temperature to call for Cooling.
10. Turn **ON** electric power. At the end of the five minute anti-cycle delay, the unit should start and run.
11. Shut **OFF** electric power at unit disconnect.
12. Replace all service access panels.

10. Operation And Maintenance Instructions

WARNING

Electrical shock hazard.

Turn off electric power supply at disconnect switch or service panel before removing any access or service panel from unit.

Failure to follow this warning can result in property damage, personal injury, and/or death.

Turning Off the Unit

Heating

1. Set thermostat selector to **OFF** and fan switch to **AUTO**.
2. If electric heat is running at time of shut-down, wait 2.5 minutes then shut **OFF** electric power supply at disconnect switch or service panel. (No wait is necessary if electric heat was not running within 2.5 minutes prior to shut-down.)

Cooling

1. Set thermostat selector to **OFF** and fan switch to **AUTO**.
2. To shut the unit down completely, shut **OFF** electric power supply at disconnect switch or service panel.

Starting the Unit After Shutdown

Heating

1. Set the thermostat to **OFF**.
4. Turn **ON** electric power.
5. Set thermostat to desired temperature and set selector to **HEAT**. Unit will come on and operate automatically under control of the thermostat.

Cooling

CAUTION

To prevent possible damage to the compressor(s), do NOT operate on cooling when outdoor temperature is below 35°F (2°C).

NOTE: An optional low ambient kit is available that allows the unit to operate at temperatures down to 0°F (-18°C).

1. Turn **ON** electric power.
2. Set thermostat to desired temperature and set system switch to **COOL**. The unit will come on and operate automatically under control of the thermostat.

Close all doors and windows. The unit may run continuously for several hours or longer on the initial run because of residual heat and moisture in the building. This is normal for any air conditioning system.

Thermostat Fan Switch Operation

The circulating air blower will run continuously with the fan selector switch in the **ON** position. When the fan selector switch is in the **AUTO** position, the blower will run during each heating or cooling cycle.

Adjusting Room Temperatures

If the temperature in individual rooms is not as desired, balance the system by adjusting the dampers in the branch ducts (see **Figure 16**). Adjust a little at a time and wait a day after each change to judge the effect. Once the dampers are adjusted for normal weather conditions, it is best to leave them that way. Compensate for temporary weather changes by adjusting the thermostat setting.

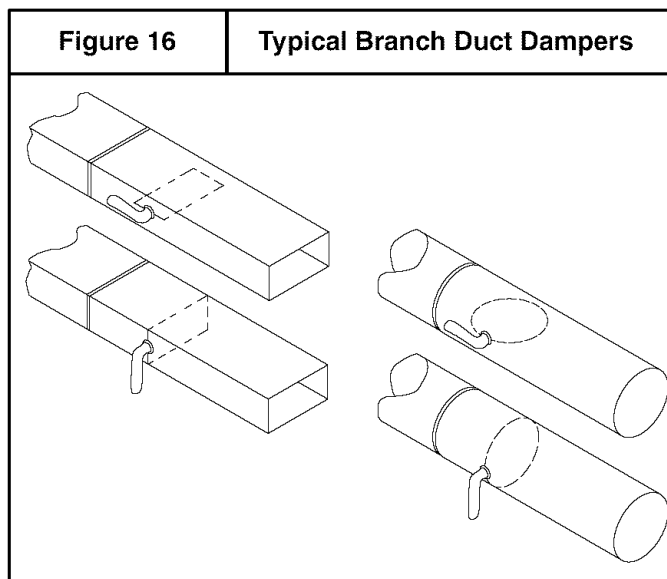

Monthly Maintenance and Inspection Checks

Air Filters (Factory Installed)

CAUTION

Do NOT operate unit without all air filters installed in the unit.

Dirty filters are the most common cause of compressor failures and inadequate heating and cooling performance.

Inspect filters at least monthly and replace or clean as required.

Washable filters may be cleaned by soaking in mild detergent and rinsing with cold water. Install filters so that the arrows on the side point in the direction of air flow.

Filter racks are accessible through the filter access panel.

Disposable Replacement Filters

For 20 ton units: 4 filters 20" x 30" x 2"

To replace disposable filters:

1. Remove filter access panel.
2. Remove the bottom filters.
3. The front of the center rail is attached to the unit by a keyhole/screw connection. Unhook the front of the center rail, swing it down approximately four inches (100mm), and hook the keyhole on the screw provided.
4. Remove the bottom filters.
5. Replace bottom filters, center rail, and top filters.

6. Replace filter access panel.

Cooling Season Checks (Monthly)

Condenser Coil

Keep the condenser inlet and outlet area clean and free of leaves, grass clippings and other debris. Grass should be kept short in front of the condenser inlet. Shrubbery **MUST** be trimmed back so it is no closer than 30 inches (762 mm) to condenser coil.

Condensate Drain

Check for condensate drainage. Clean as required.

Annual Maintenance and Inspection

WARNING

Electrical Shock, Fire and Explosion Hazards.

Turn off electric power supply at disconnect switch or service panel before removing any access or service panel from unit.

Failure to follow this warning can result in property damage, personal injury, and/or death.

The annual inspection should include cleaning as required to ensure efficient operation of the unit.

NOTE: All bearings are sealed and no lubrication is required.

Circulating Air Blower

Visually inspect the blower wheel for accumulations of dirt or lint. Clean the compartment and the blower wheel. If accumulation is excessive on blower wheel or does not remove easily, it will be necessary to remove the blower assembly.

11. Rigging Instructions

Figure 17

Rigging Instructions

INSTRUCTIONS DE SOULEVAGE



AVERTISSEMENT

SI CET AVERTISSEMENT N'EST PAS RESPECTÉ, IL PEUT EN RÉSULTER DES DÉGÂTS MATÉRIELS, DES DOMMAGES CORPORELS OU LA MORT.

- TOUS LES PANNEAUX DOIVENT ÊTRE EN PLACE AU MOMENT DU MONTCHARGE ET SOULEVAGE.
- ACCROCHEZ LES CHÂÎNES DE SOULEVAGE À TRAVERS LES TROUS DE LA BARRE DE BASE, COMME LE MONTRE DETAIL-A.
- UTILISEZ DES PLANCHES D'ÉLARGISSEMENT AU MOMENT DU SOULEVAGE POUR ÉVITER DES DOMMAGES À L'APPAREIL.
- ASSUREZ QUE LE MONTECHARGE ET LES CHÂÎNES DE SOULEVAGE SONT SUFFISANT POUR MANOEUVRER LES POIDS ÉNUMÉRÉS.

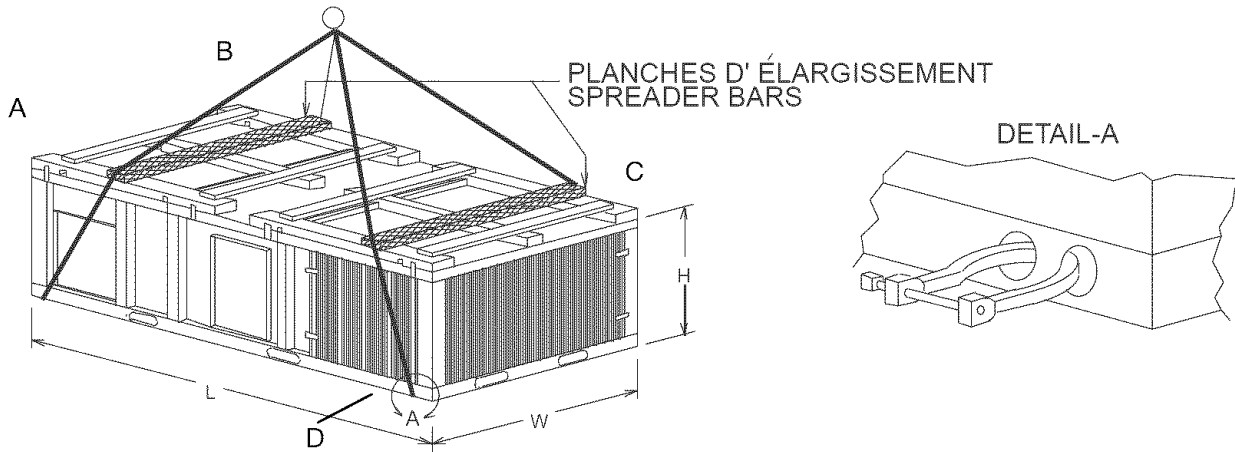

RIGGING INSTRUCTIONS



WARNING

FAILURE TO FOLLOW THESE INSTRUCTIONS CAN RESULT IN PROPERTY DAMAGE, BODILY INJURY OR DEATH.

- ALL PANELS MUST BE IN PLACE WHEN RIGGING AND LIFTING.
- HOOK RIGGING SHACKLES THROUGH HOLES IN BASE RAIL, AS SHOWN IN DETAIL-A.
- USE SPREADER BARS, WHEN RIGGING, TO PREVENT UNIT DAMAGE.
- BE SURE RIGGING AND SHACKLES ARE SUFFICIENT TO HANDLE WEIGHT LISTED.

1071210

CORNER WEIGHTS in LBS. (KG)

UNIT	OPERATING WEIGHT	CORNER WEIGHTS			
		A	B	C	D
20 TON	1700	300 (136)	400 (182)	500 (227)	500 (227)