

# **Installation Instructions**

## **SINGLE PACKAGE AIR CONDITIONERS**

**PAF & APFM Series - 3 to 5 TON  
THREE PHASE**

# Safety Labeling and Signal Words

## Danger, Warning and Caution

The signal words **DANGER**, **WARNING** and **CAUTION** are used to identify levels of hazard seriousness. The signal word **DANGER** is only used on product labels to signify an immediate hazard. The signal words **WARNING** and **CAUTION** will be used on product labels and throughout this manual and other manuals that may apply to the product.

### Signal Words

**DANGER** - Immediate hazards which **WILL** result in severe personal injury or death.

**WARNING** - Hazards or unsafe practices which **COULD** result in severe personal injury or death.

**CAUTION** - Hazards or unsafe practices which **COULD** result in minor personal injury or product or property damage.

### Signal Words in Manuals

The signal word **WARNING** is used throughout this manual in the following manner:

**WARNING**

The signal word **CAUTION** is used throughout this manual in the following manner:

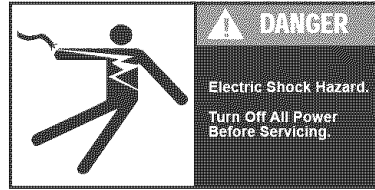
CAUTION

### Product Labeling

Signal words are used in combination with colors and/or pictures on product labels. Following are examples of product labels with explanations of the colors used.

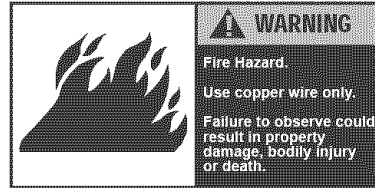
### Danger Label

White lettering on a black background except the word **DANGER** which is white with a red background.



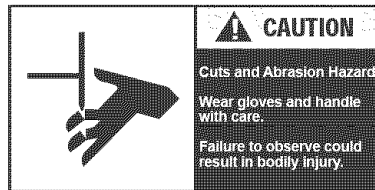
### Warning Label

White lettering on a black background except the word **WARNING** which is black with an orange background.



### Caution Label

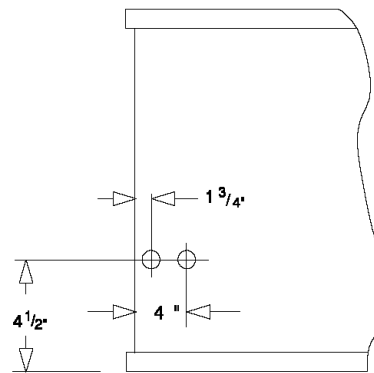
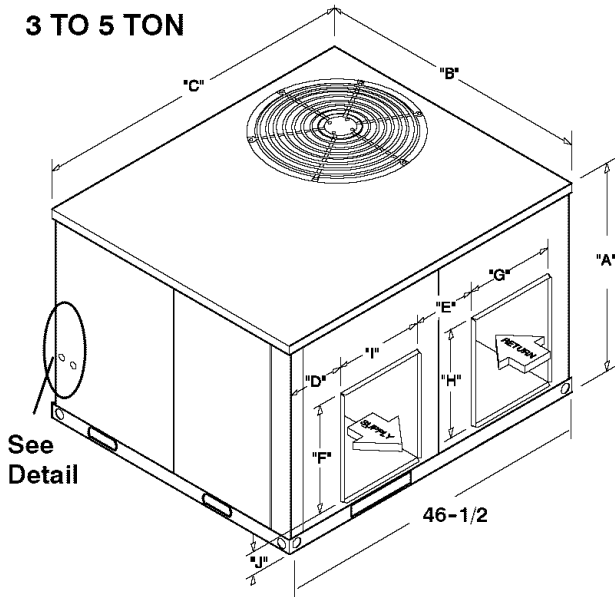
White lettering on a black background except the word **CAUTION** which is black with a yellow background.



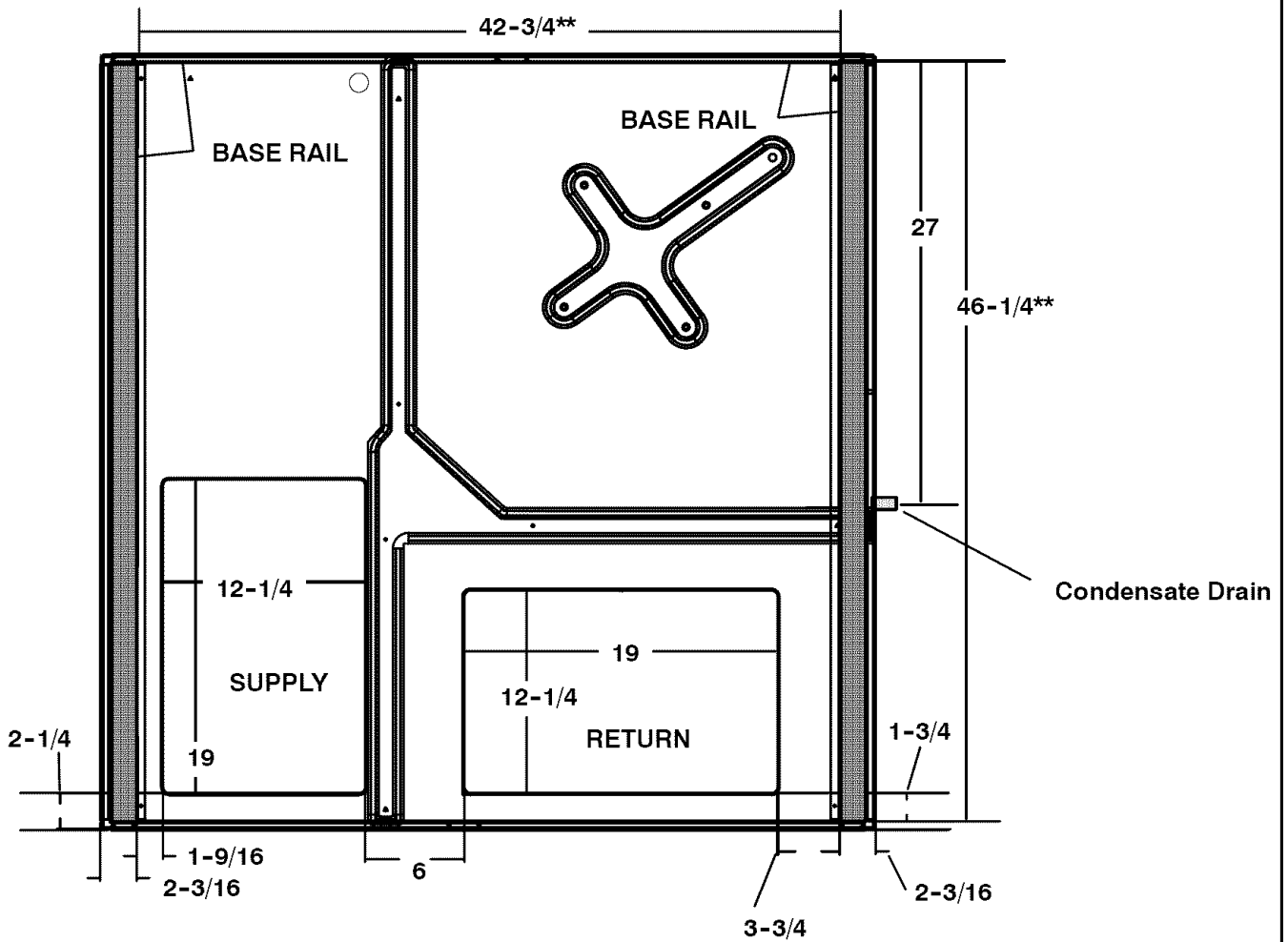
**UNIT DIMENSIONS**

**3 TO 5 TON**

All Dimensions In Inches



**BASE PAN - CHASSIS**



UNIT SIZE	A	B	C	D	E	F	G	H	I	J
3 Ton	29-1/2	47-1/2	47-1/2	3	9-1/2	12	14	12	14	4-1/2
4 TO 5 Ton	37-1/2	47-1/2	47-1/2	4	6-1/2	19	19	12	12	4-1/2

\*\* Measured from inside to inside on base rails.

# SAFE INSTALLATION

## WARNING

Installation or repairs made by unqualified persons can result in hazards to you and others. Installation **MUST** conform with local building codes or, in the absence of local codes, with the ANSI Z223.1 and the National Electrical Code NFPA70-1990 or in Canada the National Standard CAN/CGA B149-1 and CSA C.22.1 - Canadian Electrical Code Part 1.

The information contained in this manual is intended for use by a qualified service technician familiar with safety procedures and equipped with the proper tools and test instruments.

Failure to carefully read and follow all instructions in this manual can result in furnace malfunction, property damage, personal injury and/or death.

- Seal supply and return air ducts.
- Check to see that filters are installed correctly and are the proper type and size.

**NOTE:** It is the personal responsibility and obligation of the customer to contact a qualified installer to ensure that the installation is adequate and conforms to governing codes and ordinances.

## LOCATING THE UNIT

### ACCESS PANELS

See **FIGURE 1** for a general view of unit and location of access panels.

### CLEARANCES

The location **MUST** allow for minimum clearances and should not be adjacent to a patio or other area where the unit's operating sound level might be objectionable. (see **FIGURE 1**). In addition, local codes **MUST** be observed.

**NOTE:** Units with available filter racks, need a 26" minimum clearance at side of unit for removal of filters. See chart below if unit is going to be placed near combustible construction or materials.

While minimum clearances are acceptable for safety reasons, they may not allow adequate air circulation around the unit for proper operation in the cooling mode. Whenever possible, it is desirable to allow additional clearance, especially around the condenser inlet and discharge openings.

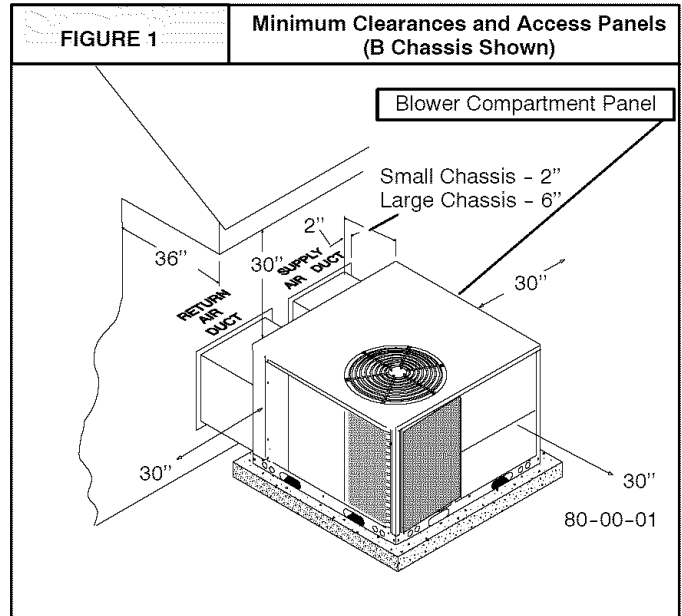
Do **NOT** install the unit in a location that will permit discharged air from the condenser to recirculate to the condenser inlet.

### CAUTION

Do **NOT** operate unit in a corrosive atmosphere containing chlorine, fluorine, or any other corrosive chemicals.

### Minimum Clearances to Combustible Construction

Condenser Inlet .....	30"
Blower Service (Side) .....	30"
Control Service Side .....	30"
Clearance between 3 Ft. Overhang and Top of Unit .....	30"
Combustible Base (Wood or Class A, B or C roof covering material) .....	0"



## INSTALLATION

### NOTICE

**Unit will NOT operate properly unless it is installed level front to rear and side to side. The slope MUST NOT be greater than 1/8" per foot (10mm per meter). For side to side leveling, the drain side MUST always be lower.**

### Ground Level Installation

Ground level platform requirements:

- The unit **MUST** be situated to provide safe access for servicing.
- Platform may be made of either concrete or pressure treated wood and **MUST** be level and strong enough to support unit weight.
- Position platform separate from building foundation.
- Install in well-drained area, with top surface of platform above grade level.
- Platform must be high enough to allow for proper condensate trap installation and drainage. See **FIGURE 2** and associated text for more information about condensate drainage.

## Rooftop Installation

Rooftop platform requirements:

- The unit **MUST** be situated to provide safe access for servicing.
- The existing roof structure **MUST** be adequate to support the weight of the unit or the roof **MUST** be reinforced.  
Check the weight of the unit in relation to the roof structure and local building codes or ordinances and reinforce roof structure if necessary. See the last page of this manual for unit weights.
- Support for the unit **MUST** be level and strong enough to carry unit weight. The support may consist of a platform or a combination of platform and roof beams or curb.
- See *Hoisting* section for hoisting instructions.

## HOISTING

**NOTE:** All access panels **MUST** be secured in place before hoisting.

The unit should be hoisted with two lifting slings. Attach the slings to rigging shackles that have been hooked through holes in the base rail.

Two spreader bars **MUST** be placed on top of the unit to protect the unit from damage from the pressure exerted by the slings. Make sure that all equipment is adequate to handle the weight of the unit and that the slings will not allow the unit to shift.

Refer to on the back cover of this manual for illustrated rigging instructions and weight chart.

## DOWNFLOW CONVERSION

**NOTE:** In downflow applications with roof curbs or jack stands, the center rail under the unit must be removed. The center rail is attached to the base rail with screws.

These units are adaptable to downflow use. To convert to downflow use, follow these steps:

1. Remove the blockoff plates found in the return air compartment and the supply air compartment.

**NOTE:** Blockoff plate in the supply air compartment only contains one screw. If reinstalling plate, back part of plate **MUST** fit into mating dimples on flange. To reinstall, slant plate into dimples, then put plate into position and fasten with screw.

2. Install the removed plates on the horizontal return and supply air openings.
3. Install roof curb on the building. Be sure to follow all directions included with curb and all applicable building codes in your installation.

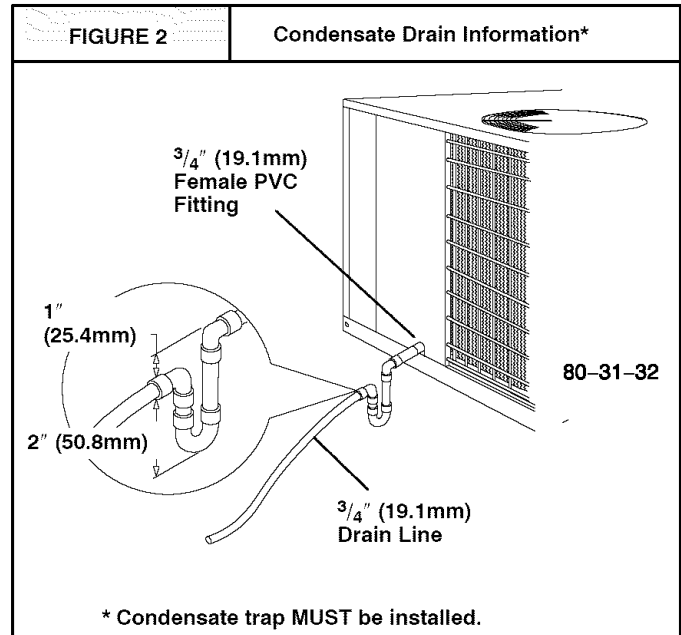
## Condensate Drain

The condensate drain outlet is a  $\frac{3}{4}$ " (19.1mm) female PVC connection located at the bottom on the left hand side (see **FIGURE 2**).

The circulating blower creates a negative pressure on the condensate drain line that can prevent the condensate from draining properly. To combat this negative pressure, a field supplied condensate trap that will allow a standing column of water of at least 2" (50.8mm) **MUST** be installed. Top of

outlet from trap **MUST** be at least 1" (25.4mm) below top of outlet from unit. **Install the trap as near to the unit as possible for proper drainage.**

A  $\frac{3}{4}$ " (19.1mm) drain line **MUST** be installed if required by local codes or if location of unit requires it. Run the drain line to an open drain or other suitable disposal point.



## Electrical Wiring

### WARNING

Electrical shock hazard.

Disconnect power at fuse box or service panel before making any electrical connections.

Unit **MUST** be grounded to electrical service panel.

Failure to follow this warning can result in property damage, personal injury, and/or death.

**NOTE:** All electrical work **MUST** conform with the requirements of local codes and ordinances and in the United States with National Electrical Code ANSI/NFPA 70-1990 (or current edition) and in Canada with CSA C22.1 - Canadian Electrical Code Part 1 (or current edition). Provide line voltage power supply from a separate fused circuit with a disconnect switch (when required) located within sight of the unit. Supply voltage, amperage, wire, fuse and disconnect switch sizes **MUST** conform with specifications in the *Parts List* and on the unit rating plate.

Wiring **MUST** be protected from possible mechanical damage and **MUST NOT** interfere with removal of access panels, filters, etc.

All exposed wiring and connections **MUST** be made with weatherproof cable or wire unless installed in conduit.

## Thermostat

The location of the thermostat has an important effect on the operation of the unit. **FOLLOW THE INSTRUCTIONS INCLUDED WITH THE THERMOSTAT FOR CORRECT LOCATION, MOUNTING AND WIRING .**

## Ground Connections

A ground lug is installed on the control plate for the ground connection (see **FIGURE 3**). Use a copper conductor of the appropriate size from the unit to a grounded connection in the electrical service panel or to a properly driven and electrically grounded ground rod. See warning above.

## Line Voltage Wiring

Do **NOT** complete line voltage connections until unit is permanently grounded. All line voltage connections and the ground connection **MUST** be made with copper wire.

Connections for line voltage are made on the unit electrical control plate (see **FIGURE 3**). For access, remove the electrical access panel .

Refer to applicable wiring diagram in the *Parts List*. Complete the line service connections to the contactor 'L' terminals on the electrical control plate. Check all screw terminals to ensure they are tight.

**NOTE:** If an Electric Heat Accessory is installed, refer to the Electric Heat Accessory *Installation Manual* to determine line voltage connections. The Electric Heat Accessory

mounts inside the unit in the heater box. Field supplied line voltage wires for the Electric Heat Accessory (separate from the field supplied line voltage wires to the unit) connect to the circuit breaker(s) in the Electric Heat Accessory.

## Converting 230V Units to 208V

To convert 230V units to 208V:

1. Turn electric power **OFF**.
2. Remove the electrical access panel.
3. Locate the 24V control transformer.
4. Remove wires from the terminal labeled "240V" on the 24V control transformer and reconnect them to the 208V terminal of the 24V control transformer.
5. Replace the electrical access panel.

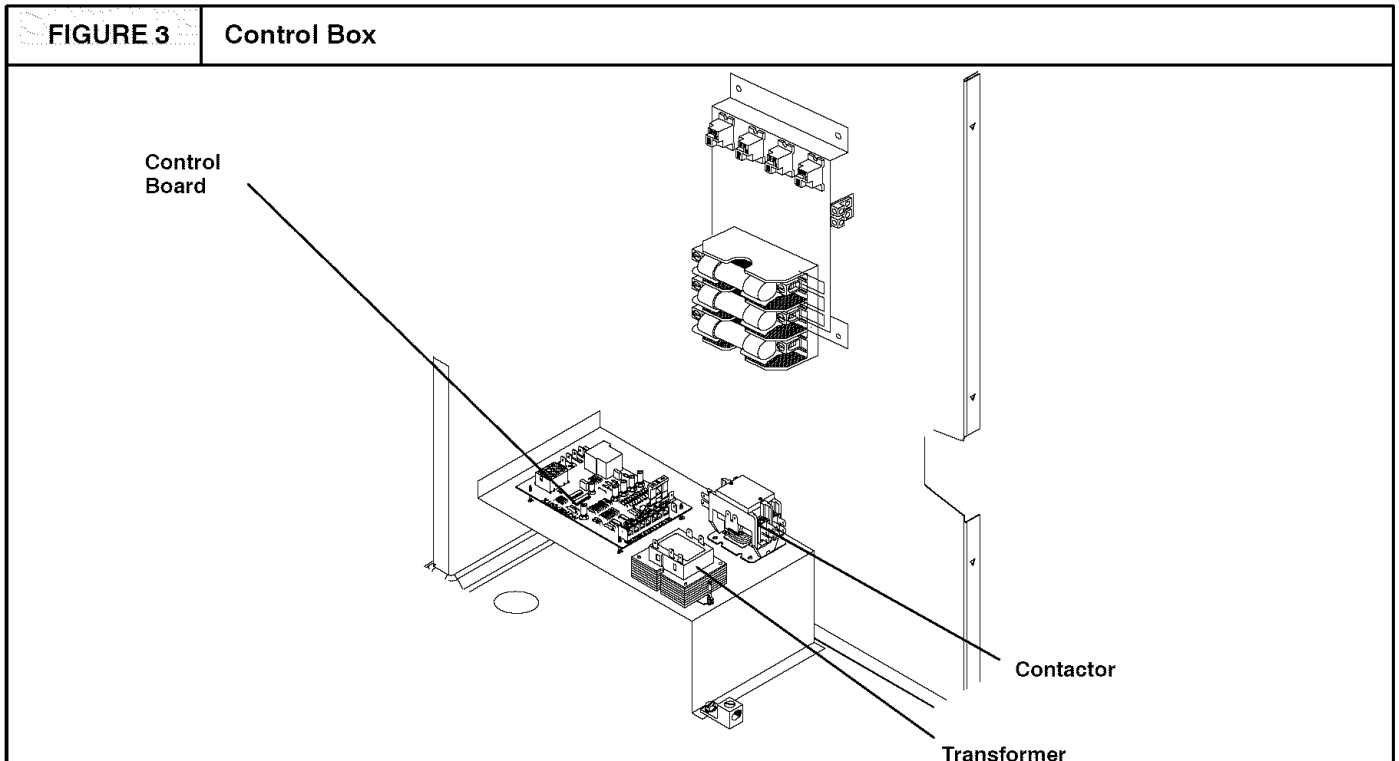
## Field Installed Equipment

Wiring to be done in the field between the unit and other devices, or between separate devices which are field installed and located, **MUST NOT** exceed the temperature limitations for type T wire and **MUST** be installed according to the manufacturer's instructions for the devices.

## Final Electrical Check

Make a final wiring check to be sure system is correctly wired. Inspect field installed wiring and the routing to ensure that rubbing or chafing due to vibration will not occur.

**NOTE:** Wiring **MUST** be installed so it is protected from possible mechanical damage.



## Air Distribution System

For airflow data (blower performance data, blower speed tap settings, etc.) see the *Parts List*.

### Ductwork

**NOTE:** The total heat gain/heat loss from the structure as expressed in total Btu/hr **MUST** be calculated by manufacturer's method or in accordance with "A.S.H.R.A.E. Guide" or "Manual J - Load Calculations" published by the Air Conditioning Contractors of America or in Canada "H.R.A.I. Residential Heating and Cooling Load Calculation Manual." **The total heat gain calculated should be equal to or less than the cooling capacity output** based on D.O.E. test procedures, steady state efficiency times input.

Ductwork, supply registers, and return air grilles **MUST** be designed and sized to handle the **unit's cooling air volume** requirements. If the unit is connected to an existing system, the ductwork **MUST** be checked to make sure it is adequate. Extra runs or larger duct sizes may have to be installed.

Maximum recommended velocity in trunk ducts is 1000 feet per minute (5.08m/s). Velocity in branches should not exceed 800 feet per minute (4.06m/s). Refer to the *Parts List* for unit air volume requirements and system sizing recommendations.

**NOTE:** Ductwork sizing affects temperature rise and cooling temperature differential. Be sure to properly size ductwork to the capacity and airflow characteristics of your unit. Failure to do so can affect limit controls, compressors, motors, and other components and will lead to premature failure of components. This will also adversely affect day to day unit performance.

Refer to unit rating plate for proper Electric Heat Accessory sizing and see the *Temperature Rise Check* section in the Electric Heat Accessory *Installation Instructions*.

### Ductwork Insulation

It is recommended that ductwork installed outdoors have a minimum of 2" (51mm) of fiberglass insulation and be covered by a weatherproof vapor barrier that is protected against damage. Caulking and flashings, or other means adequate to provide a permanent weather seal, must be used.

It is recommended that ductwork installed in attics or other areas exposed to outdoor temperatures have a minimum of 2" (51mm) fiberglass insulation and have an indoor type vapor barrier.

### Ductwork Connections

The use of flexible, **non-combustible** connectors between main trunk ducts and supply and return air plenums is recommended to minimize vibration transmission.

**NOTE:** Connect supply and return air plenums to unit in a manner that will allow the top of the unit to be removed without removing plenums. Plenums **MUST** be individually sealed to unit casing. Ducts **MUST** be terminated inside structure.

### Filters

All return air **MUST** pass through a filter before entering the unit. An electronic air cleaner, optional filter racks or other accessible filter arrangements **MUST** be installed in the *return* air ductwork. Minimum recommended filter areas are based on a velocity of 300 ft/min (1.2m/s) for disposable filters and 500 ft/min (2.54m/s) for washable high velocity filters.

### CAUTION

**Do NOT operate the unit without all filters in place.**

## Start-up Procedures

### WARNING

Electrical shock hazard.

Use extreme care during all of the following checks and procedures.

Make sure electric power is turned OFF as instructed in appropriate steps.

Failure to follow this warning can result in property damage, personal injury, and/or death.

## Circulating Air Blower

### Determining Blower Speed

1. Turn electric power **OFF**.
2. From the system design, determine the external static pressure (ESP) for the supply ducts, return ducts and registers, diffusers, grilles, dampers, heaters and filters.
3. To your system ESP determined in **Step 2**, add 0.05 In. W.C. for a wet coil.
4. From the system design, determine the desired cooling airflow in cubic feet per minute (CFM).
5. Locate the unit's Blower Performance Data table in the tech data sheet for the unit's voltage. (The tech data sheet is attached to the inside of the electrical access panel and is also published in the *Parts List*.) From the table, determine the speed tap the desired airflow requires.

6. See next section, *Speed Taps*, to set the blower motor speed terminal block (speed taps) determined in the following steps.

## Speed Taps

After determining the required CFM and speed tap data from the tech data sheet, follow the steps below to change speeds if necessary.

**NOTE:** The yellow lead **MUST** always be connected to the speed tap block at the common quick connect terminal. The terminal is identified as **COM**. Also, this is the only lead which is  $\frac{3}{16}$ " wide. All other quick connects are  $\frac{1}{4}$ " wide.

Refer to the unit's wiring diagram, which is attached to the inside of the electrical access panel and is also published in the *Parts List* for the desired speed tap to achieve the required CFM for the applicable model.

## Cooling, Heating (Heat Pump) and Auxiliary Electric Strip Heat

**NOTE:** The cooling, heat pump and strip heat airflows are all on the same speed tap. The refrigerant system requires the same specific CFM for proper operation in the cooling and the heat pump mode. For this reason, cooling and heating airflow must be the same. **DO NOT SPLITOUT INTO A COOLING SPEED AND HEATING SPEED.**

## Check Before Starting

1. Check that the blower motor speed terminal block is set to the proper speed. Refer to the unit wiring diagram and the Technical Labels in the *Parts List*.

2. Check to see that clean, properly sized field supplied air filters are installed in the return air duct.
3. Inspect the inside of the unit to be sure that all wires are in place and all tools, etc. are removed.
4. Replace all service access panels.

Check the unit's operation as outlined in the following instructions. If any unusual sparking, odors or noises are encountered, shut **OFF** electric power immediately. Re-check for wiring errors, or obstructions in or near blower motors.

## Sequence of Operation

### Cooling Mode: Energized (R,G,Y1)

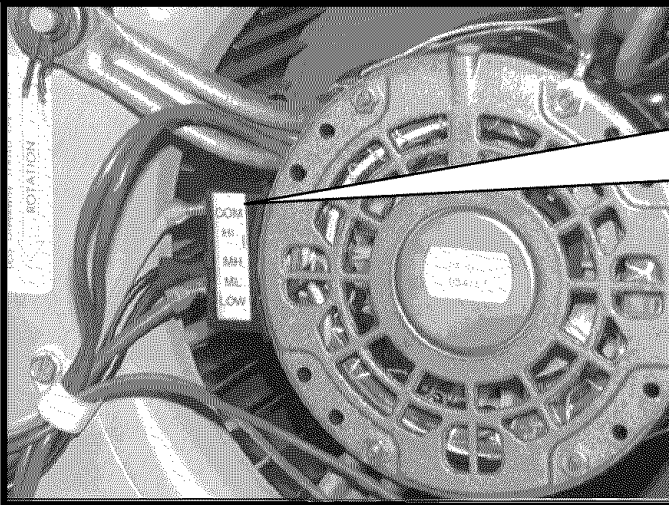
**(a) When high and low voltage is initially applied to unit:**

- (1) **On a call for cooling.....:**  
The compressor and condenser fan will energize immediately. The evaporator blower motor will energize immediately.
- (2) **When the cooling setpoint has been satisfied.....:**  
The compressor and condenser fan will de-energize immediately. The evaporator blower motor will have a delay off and will de-energize after 30 seconds.

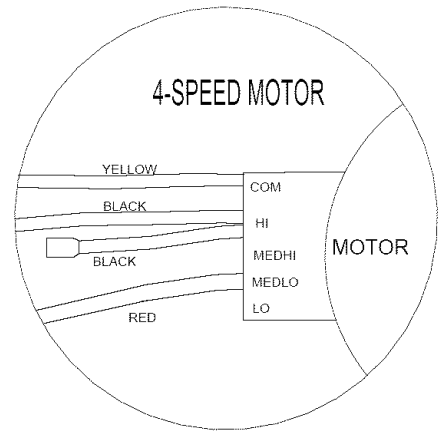
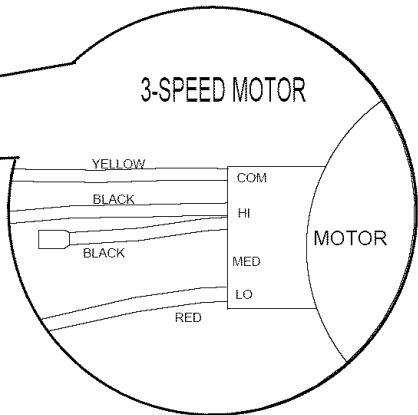


FIGURE 4

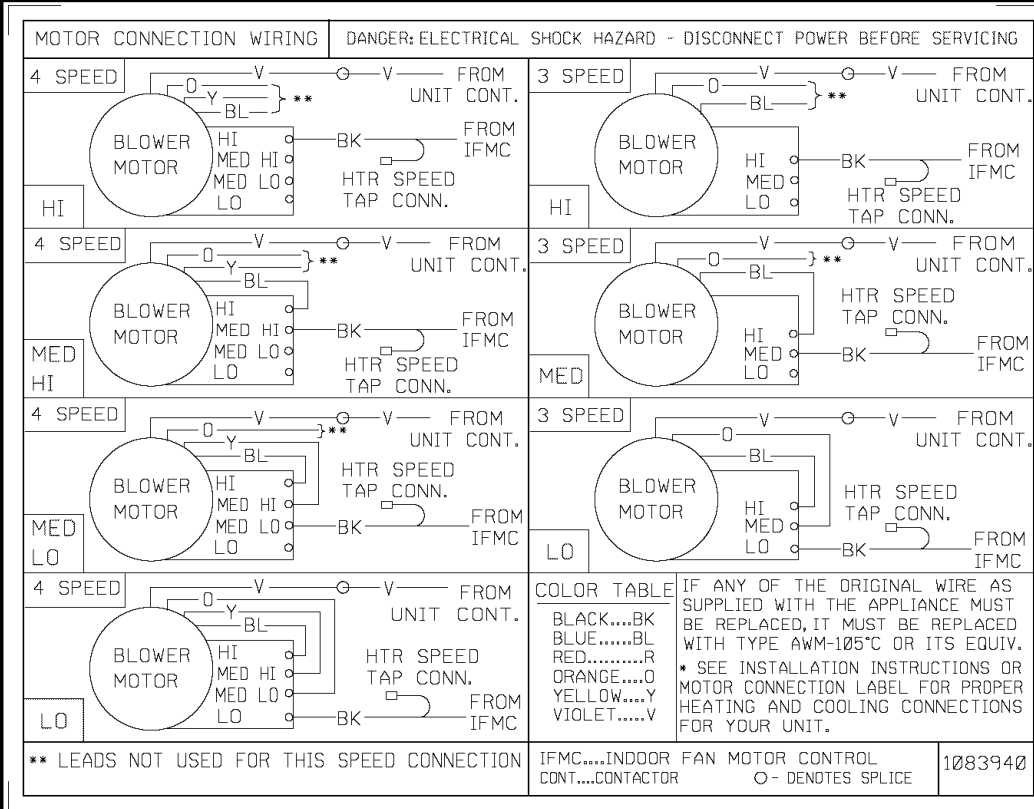
Blower Motor Speed Taps - 208/230 Volt(3-Speed and 4-Speed Motors)



**BE SURE TO CHECK BLOWER MOTOR SPEED DATA IN UNITS TECHNICAL INFORMATION LABEL ON THE UNIT**



Blower Motor Speed Taps - 460 Volt (3-Speed and 4-Speed Motors)



**BE SURE TO CHECK BLOWER MOTOR SPEED DATA IN UNITS TECHNICAL INFORMATION LABEL ON THE UNIT**

# Operation

## Cooling

Adjust thermostat setting to desired temperature and set thermostat Heat-Cool switch to **COOL**. The unit will come on and operate automatically under control of the thermostat. Close all doors and windows. The unit may run continuously for several hours or longer on the initial run because of residual heat and moisture in the house. This is normal for any air conditioning system.

### CAUTION

**Do NOT operate unit on cooling when the outdoor temperature is below 40°F (4.4°C). This is necessary to prevent possible damage to the compressor.**

## Turning The Unit Off

1. Set the thermostat selector switch to **OFF** and set the fan switch to **AUTO**. To restart, set thermostat selector switch to **COOL** and set thermostat to temperature desired.
2. To shut the unit down completely, turn electric power **OFF**.

## Thermostat Fan Switch Operation

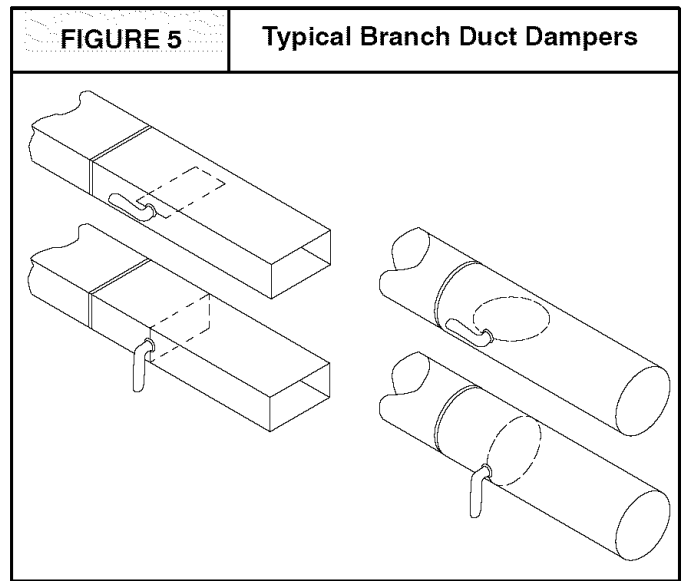
With the thermostat fan switch in the **ON** position, the circulating air blower will run continuously.

With the thermostat fan switch in the **AUTO** position, the circulating air blower will only run during a cooling or heating

cycle and when the electric heat accessory is required if the electric heat accessory is installed.

## Adjusting Room Temperatures

If the temperature in individual rooms is not as desired, balance the system by adjusting the dampers in the branch ducts. Adjust a little at a time and wait a day after each change to judge the effect. Once the dampers are adjusted for normal weather conditions, it is best to leave them that way. Compensate for temporary weather changes by adjusting the thermostat setting .



# Maintenance

## Air Filters, Condenser Coil and Condensate Drain Maintenance

Refer to Home Owners Manual supplied with your heat pump for information on filter sizes, condenser coil clearances from shrubbery and condensate drainage allowances.

### CAUTION

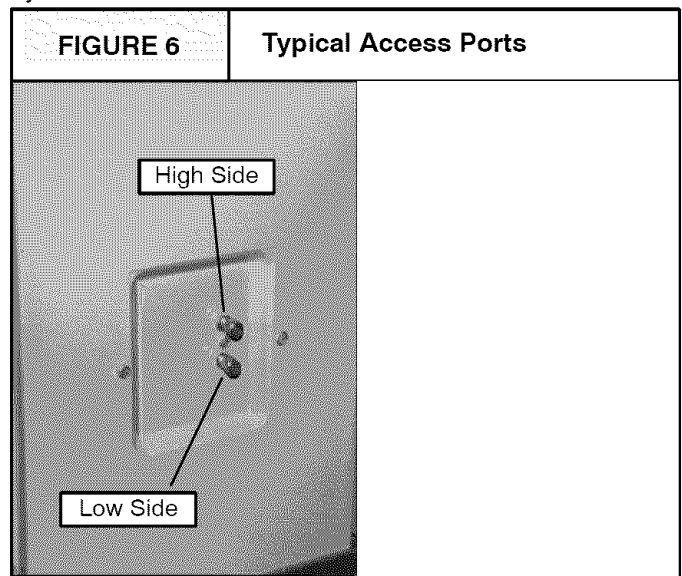
**Do NOT operate unit without filters in place. Inspect filters monthly and clean and/or replace as needed.**

## Refrigeration Access Ports

This unit is equipped with refrigeration access ports mounted on the side of the unit. Refer to **FIGURE 6** for identification of ports.

This unit is also equipped with internal access ports on the suction and discharge tubing line which can be used for

evacuation, pull down and recharging of the refrigeration system.



## Annual Maintenance and Inspection

### Condenser Fan Motor

#### CAUTION

Do NOT use 3 in 1 oil, penetrating oil, WD40 or similar oils to oil motor bearings.

Oil the condenser fan motor after five years of operation and every five years thereafter.

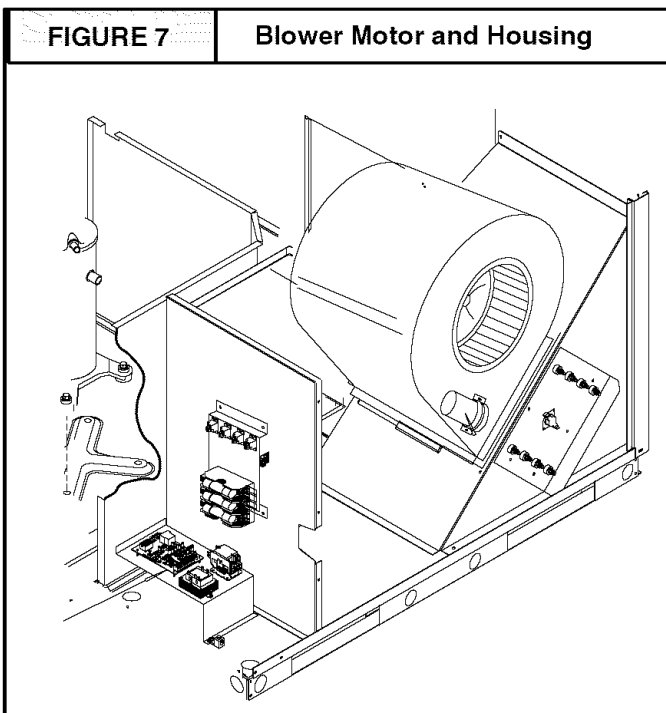
Use SAE 10W30 motor oil. To oil, remove the hole plugs from the motor end bells and add several drops (approximately 1/2 teaspoonful) of oil with a squeeze type, flexible tube oiler. Replace hole plugs after oiling. Do NOT over oil.

Clean the surrounding area and the condenser and evaporator coils. Use caution to avoid damage to coil fins. Do not use an acid-based cleaner on coated fin material.

### Blower Motor Access

To remove the blower motor and/or the blower motor housing assembly, remove the blower access panel.

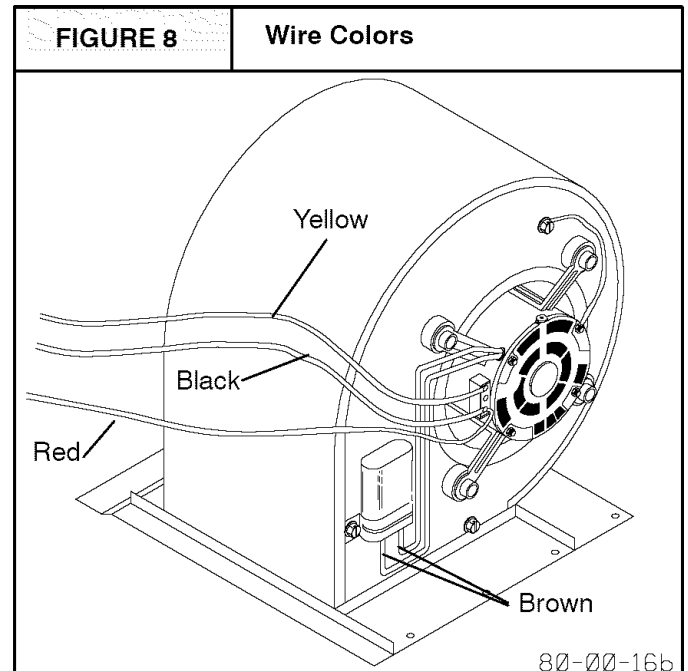
Refer to FIGURE 7 for a view of blower motor and compartment.



### Blower Wire Color Identification

Use FIGURE 8 to identify wires on blower motor.

To change speed tap settings, see *Speed Taps* in the *Start-up Procedures* section of this manual.



### Circulating Air Blower

Visually inspect the blower wheel for accumulations of dirt or lint. Clean the compartment and the blower wheel. If accumulation is excessive on blower wheel, or does not easily remove, it will be necessary to remove the blower assembly.

#### CAUTION

Do NOT use 3 in 1 oil, penetrating oil, WD40 or similar oils to oil motor bearings.

Oil the blower motor by adding 1/2 teaspoonful (1 cc) of SAE 10W30 to each motor bearing. The blower motor should be oiled after five years of operation and every five years thereafter.

**INTERNATIONAL COMFORT PRODUCTS**  
**LIMITED WARRANTY CERTIFICATE**  
*For Cooling & Heating Products*

**SAVE THIS CERTIFICATE. It gives you specific legal rights, and you may also have other rights which may vary from state to state and province to province.**

If your unit needs servicing, contact a qualified dealer or qualified service technician of your choice. When requesting service, please have the model and serial number from each unit in your heating and/or cooling system readily available. If your dealer needs assistance, the distributor is available to provide support and we, in turn, support its efforts.

Fill in the installation date and model and serial numbers of the unit in the space provided below and retain this Limited Warranty for your files.

**GENERAL TERMS**

Subject to the conditions and limitations stated herein, during the term of this Limited Warranty, we will provide a replacement for any functional component part (as defined below) of your unit found to be defective in materials or workmanship. The term of this Limited Warranty is five years from installation on Residential Products and one year from installation on Commercial Products. Except as otherwise stated in the "Additional Terms" section, this Limited Warranty covers only the original purchaser and subsequent transferees, and only while the unit remains at the site of the original installation (except for mobile home installations), and only if the unit is installed inside the continental United States, Puerto Rico, Alaska, Hawaii or Canada. In addition, the Limited Warranty applies only if the unit is installed and operated in accordance with the printed instructions accompanying the unit, and in compliance with all applicable installation and building codes and good trade practices. As used in this Limited Warranty, "installation" means the original installation of the unit.

THERE ARE EXCEPTIONS to this Limited Warranty as described on the reverse side of this page. All replacement parts will be warranted for the unused portion of the warranty coverage period on the unit. The part to be replaced must be returned by the dealer to a distributor that sells products for International Comfort Products, in exchange for the replacement part. In lieu of providing a replacement part, we may, at our sole option, refund to you an amount equal to the distributor's component purchase price from us, or provide to you a credit equal to that amount to be applied toward the purchase of any new unit that we distribute. If a credit for a new unit is given in lieu of a replacement part, the rating plate from the unit being replaced must be submitted on a warranty claim, and your dealer must make the unit being replaced available to our distributor for disposition. As a condition to warranty coverage, the unit must receive yearly maintenance, as described in the owner's manual, by a dealer. Satisfactory proof of yearly service by a dealer may be required.

"Functional component parts" include only the following: blower motor, unit-mounted sensors & timers, condenser motor, evaporator coil, condenser coil, condenser fan, capacitor, transformer, single-phase strip heat elements, expansion device, reversing valve, solenoid valve, service valve, electronic and electro-mechanical control board, ignitor, ignition module, draft inducer assembly, burner pilot, gas valve, limit control, pressure switch, relays and contactors, blower wheel, interlock switch, crosslighter, pilot shield, gas & oil burners, oil pump assembly, accumulators and factory installed driers and strainers.

This Limited Warranty **DOES NOT COVER** any labor, material, refractory chambers, oil nozzles, refrigerant, refrigerant inspection and refrigerant reclaiming, freight and/or handling charges associated with any repair or replacement and such charges will be your responsibility.

To establish the installation date for any purpose under this Limited Warranty, you must retain the original records that can establish the installation date of your unit. If you do not provide such documents the start date of the term of this Limited Warranty will be based upon the date of unit manufacture, plus thirty (30) days. In establishing that the required yearly service has occurred, you must furnish proof of yearly service by a qualified service technician.

This Limited Warranty does not cover: (a) failure or damages caused by accident, abuse, negligence, misuse, riot, fire, flood, or Acts of God (b) damages caused by operating the unit where there is a corrosive atmosphere containing chlorine, fluorine, or any other damaging chemicals (other than those found in a normal residential environment) (c) damages caused by an unauthorized alteration or repair of the unit affecting its stability or performance (d) damages caused by improper matching or application of the unit or the unit's components (e) damages caused by failing to provide proper maintenance and service to the unit in accordance with this Limited Warranty Certificate and the printed instructions originally provided with the unit (f) any expenses incurred for erecting, disconnecting, or dismantling the unit (g) parts or supplies used in connection with service or maintenance, such as refrigerant, refractory chambers, oil nozzles, filters, or belts (h) damage, repairs, inoperation or inefficiency resulting from faulty installation or application (i) electricity or fuel costs or any increase in electricity or fuel cost whatsoever including additional or unusual use of supplemental electric heat (j) units which have not had the required yearly maintenance described elsewhere in this limited warranty.

In no event shall we be liable for any incidental, consequential, or special damages or expenses in connection with any use or failure of this unit.

**We have not made, do not make, and hereby disclaim any implied condition or implied warranty of fitness for a particular use or purpose, and any implied condition or implied warranty of merchantability, to the fullest extent allowed by law. We make no express or implied warranties except as stated in this Limited Warranty certificate.**

No one is authorized to change this Limited Warranty or to create for us any other obligation or liability in connection with this unit. Any implied warranties shall last for the term of the expressed warranty contained herein. Some states and provinces do not allow the exclusion or limitation of incidental or consequential damages or do not allow limitations on how long an implied warranty or condition lasts, so the above limitations or exclusions may not apply to you. The provisions of this Limited Warranty are in addition to and not a modification of or subtraction from any statutory warranties and other rights and remedies provided by law.

**Please refer to reverse side of this page for additional terms.**

Model No. \_\_\_\_\_

Serial No. \_\_\_\_\_ Date Installed \_\_\_\_\_

**Effective on units installed After July 1, 2002.**

USA: International Comfort Products Corporation (USA) • 650 Heil-Quaker Avenue • P.O. Box 128 • Lewisburg, Tennessee 37091 • (931-270-4100)  
CANADA: International Comfort Products division of UTC Canada Corporation • 6060 Burnside Court, Unit 1, Mississauga, Ontario L5T 2T5 (905-795-8113).

Manufacturers of Airquest, Arcoaire, Clare, Comfortmaker, Dettson, Heil, Keeprite, Lincoln, Tempstar and other quality brand name private label products.

Part No. 401 06 1010 18 (Orig. 8/9/2002)

## ADDITIONAL TERMS FOR RESIDENTIAL APPLICATIONS ONLY

The Additional Terms for the components listed below are in addition to, and subject to, the General Terms on the reverse side of this page. Warranty coverage is limited to parts that fail due to defect in materials or workmanship during the specified term.

### CENTRAL GAS & OIL FURNACE HEAT EXCHANGERS\*

**Gas Model Series: C9MPV, H9MPV, T9MPV, C9MPT, H9MPT, T9MPT, C9MPD, H9MPD, T9MPD:** Limited Lifetime Warranty on heat exchangers. If a heat exchanger on one of these furnaces fails due to defect in the part, we will provide a replacement part or, at our option, credit toward the purchase of a new furnace manufactured by us. This additional Limited Warranty runs only to the original purchaser, and lasts only for as long as the original purchaser lives in the home where the furnace is initially installed.\*\* It is not transferable to any subsequent owner. If the furnace was not installed in the home owned by the original purchaser, if the original purchaser sells the home to a subsequent owner, or if proof of original purchase cannot be provided, then the limited warranty is only for 20 years from the date of original installation.

**Gas Model Series: GDL, GNL, TNE, TDE, NTC7, NDC7, NTP6, NDP6, TDE, NTV6, VNE:** A replacement heat exchanger will be provided for any heat exchanger that fails in one of these furnaces due to defect for 25 years from the original date of installation.

**Gas Model Series: NTC6, GNE, GDE, NDN6, NTG3, NDN3, FBF, NBF, NDF, NTN3, NTN6, NNE, N9MP1, N9MP2, FUH:** A replacement heat exchanger will be provided for any heat exchanger that fails in one of these furnaces due to defect for 20 years from original date of installation.

**Oil Model Series: OLR(105, 160, 182), OCF, OLF, OUF, NOLF, NOUF, OLB, OHB, ODH, FLO, MBO, LBO, NOMF:** Limited Lifetime Warranty on heat exchangers. If a heat exchanger on one of these furnaces fails due to defect in the part, we will provide a replacement part or, at our option, credit toward the purchase of a new furnace manufactured by us. This additional Limited Warranty runs only to the original purchaser, and lasts only for as long as the original purchaser lives in the home where the furnace is initially installed.\*\* It is not transferable to any subsequent owner. If the furnace was not installed in the home of the original purchaser, if the original purchaser sells the home to a subsequent owner, or if proof of original purchase cannot be provided, then the limited warranty is only for 20 years from the date of original installation.

**Oil Fired Floor Furnace: NFO:** A replacement heat exchanger will be provided for any heat exchanger that fails due to defect for 10 years from installation with the following limitation: during the sixth through tenth year, any credit toward your purchase of a component or toward the purchase of any new unit will be in an amount equal to the distributor's purchase price reduced by 20 percent for each year after the fifth year.

## ADDITIONAL TERMS FOR OIL FURNACE APPLICATIONS ONLY

- 1) OIL BURNERS - A replacement for 5 years from date of original installation for Oil Burner Parts.
- 2) OPTIONAL ACCESSORIES AND FUNCTIONAL PARTS: A replacement for 5 years from date of original installation. (Refractory and oil nozzles not included)

### GAS/ELECTRIC PACKAGED UNITS HEAT EXCHANGERS

**Model series: PGAD, PGAA, PGMD, PGME, PGF, GPFM, PGC, GPCM:** A replacement for 10 years from original date of installation.

### COMPRESSORS:\*

1) **Premium Model Units: HAC0, HAC2, HAC4, CAC0, CAC2, CAC4, KAC0, TCA0, TCA2, TCA4, HHP0, HHP2, HHP4, CHP0, CHP2, CHP4, TCH0, TCH2, TCH4, PGME, PYMC, PHAD, PGAD, PA95, PAPC, PAK, APK:** To the original purchaser a replacement for 10 years from original date of installation, only if the unit is installed with factory matched coils, except air conditioner condensing units with a nominal SEER of 10 may be matched with evaporator coils of the same nominal tonnage regardless of manufacturer and in accordance to factory recommendations. This limited 10-year warranty is not transferable to any subsequent owner. HOWEVER, if the unit was not installed in the home owned by the original purchaser, if the purchaser sells the home to a subsequent owner, or if proof of original purchase cannot be provided, then the limited warranty is only for 5 years from the original date of installation.\*\*

2) **All Other Models: Air Conditioners, Heat Pumps, & Combination Gas/Electric Units: NAC0, NAC2, NHP0, NHP2, AO, A2, HO, H2, PGF, PGC, GPFM, GPCM, PAF, APFM, PHF, HPFM, PGAA, PGMD, PA55, PH55, PAPA, PYPA:** A replacement for 5 years from date of original installation, only if: (a) air conditioner condensing units with SEER rating in the range of 10 to 11 SEER are matched with evaporator coils of the same nominal tonnage regardless of manufacturer and in accordance to factory recommendations, or (b) heat pump condensing units are used with factory matched coils, unless written approval to do otherwise is obtained from manufacturer.

## ADDITIONAL TERMS FOR COMMERCIAL APPLICATIONS ONLY

For purposes of this warranty a commercial application is one in which: the product has over 5 tons nominal cooling capacity, or is designed for operation with 3 phase electrical power, or is installed in a commercial establishment such as a beauty or hair salon, hospital, school, restaurant, church, hotel etc..

**3-Phase Models: PGF, GPFM, GPF, PGAD, PGME, PGB, PGMG, PGMF, PGS, PGE, APE, PAE, PAB, PAMD, PAS, PAF, APFM, APF, PHB, PHE, PYMD, HPB, PHS, CAC, ACC, CAE, ACE, CHC, HCC, CHE, HCE:**

The additional Terms of the components listed below are in addition to and subject to the General Terms on the reverse side of this page.

- 1) **GAS FIRED HEAT EXCHANGERS (ALL MODELS):\*** A replacement for 10 years from date of original installation.
- 2) **COMPRESSORS (ALL MODELS):\*** A replacement for 5 years from date of original installation.
- 3) **OPTIONAL ACCESSORIES AND FUNCTIONAL COMPONENT PARTS (ALL MODELS):\*** A replacement for 1 year from date of original installation.
- 4) **COMMERCIAL OIL MODELS: OLR210, OLR350, OTF210, AMT3, AMT4, AMP3:** Ten(10) Year Limited Warranty on heat exchangers.

\*To receive advantage of your limited warranty, you must provide proof of yearly service by a qualified service technician.

\*\*To receive advantage of your warranty, you must retain the original records that can establish the installation date and proof of purchase of the unit.

### MINI SPLITS:

**Summary - Mini Splits Warranted for one (1) year on all replacement parts.**

#### Additional terms for Mini Splits:

The additional Terms of the components listed below are in addition to, and subject to, the General Terms on the reverse side of this page.

1) **Compressors (All Models):** A replacement compressor will be provided for all compressors that fail due to defect for 5 years from date of original installation.

2) **Optional Accessories and Functional Components Parts (All Models):**

A replacement part will be provided for all parts that fail due to defect for one (1) year from date of original installation.

Failure to maintain the equipment through annual maintenance by a qualified service technician shall void the warranty. Proof of service will be required with all warranty claims. Proof of purchase and installation date must be submitted with all claims.