

Installation Instructions

NTC5/GNJ NTN5/GNJ (NOx Models) Upflow/Horizontal Series

SAFETY REQUIREMENTS

Recognize safety information. This is the safety-alert symbol . When you see this symbol on the furnace and in instructions manuals be alert to the potential for personal injury.

Understand the signal words *DANGER*, *WARNING*, or *CAUTION*. These words are used with the safety-alert symbol. *DANGER* identifies the most serious hazards, those that **will** result in severe personal injury or death. *WARNING* signifies a hazard that **could** result in personal injury or death. *CAUTION* is used to identify unsafe practices that **could** result in minor personal injury or product and property damage.

Installing and servicing heating equipment can be hazardous due to gas and electrical components. Only trained and qualified personnel should install, repair, or service heating equipment.

Untrained service personnel can perform basic maintenance functions such as cleaning and replacing air filters. All other operations must be performed by trained service personnel. When working on heating equipment, observe precautions in the literature, on tags, and on labels attached to or shipped with the unit and other safety precautions that may apply.

Follow all safety codes. In the United States, follow all safety codes including the current edition National Fuel Gas Code (NFPA) NFPA No. 54/ANSIZ223.1. In Canada, refer to the current edition of the National Standard Canada CAN/CGA-B149.1 - and .2-M91 Natural Gas and Propane Installation Codes (NSCNGPIC). Wear safety glasses and work gloves. Have fire extinguisher available during start-up and adjustment procedures and service calls.

These instructions cover minimum requirements and conform to existing national standards and safety codes. In some instances, these instructions exceed certain local codes and ordinances, especially those that may not have kept up with changing residential construction practices. We require these instructions as a minimum for a safe installation.



Manufactured by:
International Comfort Products Corporation (USA)
Lewisburg, TN USA 37091

Table of Contents

1. Installation	2	6. Gas Supply and Piping	9
2. Combustion & Ventilation Air	4	7. Electrical Wiring	12
3. Gas Vent Installation	6	8. Ductwork and Filter	13
4. Horizontal Venting	8	9. Checks and Adjustments	14
5. Masonry Chimney Venting	8	10. Furnace Maintenance	16



 **DANGER**

Electric Shock Hazard

Turn Off All Power Before Servicing.

 **WARNING**

This furnace is not designed for use in mobile homes, trailers or recreational vehicles. Such use could result in property damage, bodily injury and/or death.

1. Installation

⚠ WARNING

Installation or repairs made by unqualified persons can result in hazards to you and others. Installation **MUST** conform with local codes or, in the absence of local codes, with codes of all governmental authorities having jurisdiction.

The information contained in this manual is intended for use by a qualified service technician who is experienced in such work, who is familiar with all precautions and safety procedures required in such work, and is equipped with the proper tools and test instruments.

Failure to carefully read and follow all instructions in this manual can result in furnace malfunction, property damage, personal injury and/or death.

NOTE: This furnace is design certified by the American Gas Association and the Canadian Gas Association for installation in the United States and Canada. Refer to the appropriate codes, along with this manual, for proper installation.

- This furnace is **NOT** approved for installation in mobile homes, trailers or recreation vehicles.
- Do **NOT** use this furnace as a construction heater or to heat a building that is under construction.
- Use only the Type of gas approved for this furnace (see **Rating Plate** on unit). Overfiring will result in failure of heat exchanger and cause dangerous operation. (Furnace can be converted to L.P. gas with approved kit.)
- Do **NOT** use open flame to test for gas leak.
- Ensure adequate combustion and ventilation air is provided to the furnace.
- Seal supply and return air ducts.
- The vent system **MUST** be checked to determine that it is the correct type and size.
- Install correct filter type and size.
- Unit **MUST** be installed so electrical components are protected from direct contact with water.
- It is the suggestion of this manufacturer to install fire and carbon monoxide detectors.

Safety Rules

Your unit is built to provide many years of safe and dependable service providing it is properly installed and maintained. However, abuse and/or improper use can shorten the life of the unit and create hazards for you, the owner.

- A. The U.S. Consumer Product Safety Commission recommends that users of gas-burning appliances install carbon monoxide detectors. There can be various sources of carbon monoxide in a building or dwelling. The sources could

be gas-fired clothes dryers, gas cooking stoves, water heaters, furnaces, gas-fired fireplaces, wood fireplaces, and several other items. Carbon monoxide can cause serious bodily injury and/or death. Therefore, to help alert people of potentially dangerous carbon monoxide levels, you should have carbon monoxide detectors listed by a nationally recognized agency (e.g. Underwriters Laboratories or International Approval Services) installed and maintained in the building or dwelling (see Note below).

- B. There can be numerous sources of fire or smoke in a building or dwelling. Fire or smoke can cause serious bodily injury, death, and/or property damage. Therefore, in order to alert people of potentially dangerous fire or smoke, you should have fire and smoke detectors listed by Underwriters Laboratories installed and maintained in the building or dwelling (see Note below).

Note: The manufacturer of your furnace does not test any detectors and makes no representations regarding any brand or type of detector.

- C. To ensure safe and efficient operation of your unit, you should do the the following:
1. **Thoroughly read this manual and labels on the unit.** This will help you understand how your unit operates and the hazards involved with gas and electricity.
 2. **Do not use this unit if any part has been under water.** Immediately call a qualified service technician to inspect the unit and to replace any part of the control system and any gas control which has been under water.
 3. **Never obstruct the vent grilles, or any ducts that provide air to the unit.** Air must be provided for proper combustion and ventilation of flue gases. Carbon monoxide or "CO" is a colorless and odorless gas produced when fuel is not burned completely or when the flame does not receive sufficient oxygen.

Freezing Temperatures and Your Structure

⚠ WARNING

Freeze warning.

Turn off water system.

If your unit remains shut off during cold weather the water pipes could freeze and burst, resulting in serious water damage.

Your unit is equipped with safety devices that may keep it from operating if sensors detect abnormal conditions such as clogged exhaust flues.

If the structure will be unattended during cold weather you should take these precautions.

1. Turn off main supply water into the structure and drain the water lines if possible. Open faucets in appropriate areas.
2. Have someone check the structure frequently during cold weather to make sure it is warm enough to prevent pipes from freezing. Suggest they call qualified service agency, if required.

⚠ WARNING

Poison carbon monoxide gas hazard.

If this furnace is replacing a previously common-vented furnace, it may be necessary to resize the existing vent line and chimney to prevent oversizing problems for the other remaining appliances(s). See applicable codes and *Venting and Combustion Air Check in Gas Vent Installation* section.

Failure to properly vent this furnace or other appliances can result in property damage, personal injury and/or death.

Location and Clearances

If furnace is a replacement, it is usually best to install the furnace where the old one was. Choose the location or evaluate the existing location based upon the minimum clearance and furnace dimensions (Figure 1).

CAUTION

Do NOT operate furnace in a corrosive atmosphere containing chlorine, fluorine or any other damaging chemicals. Refer to Combustion & Ventilation Air section, Contaminated Combustion Air.

Figure 1

Dimensions and Clearances

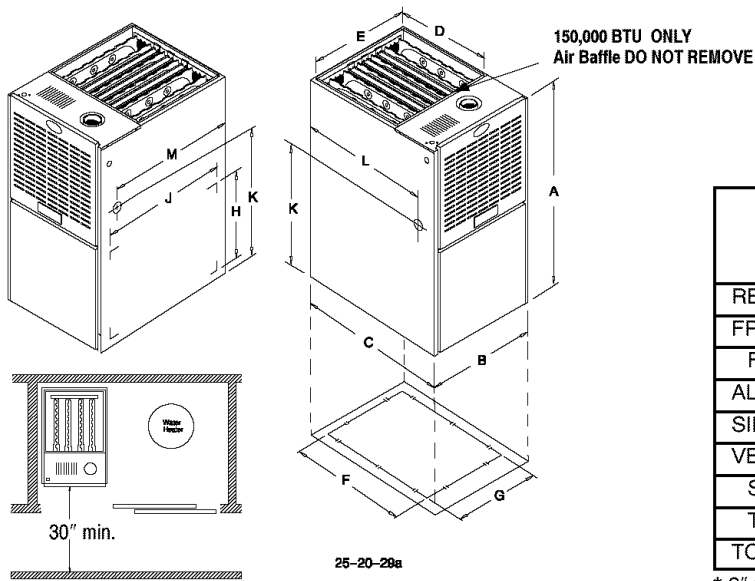

MINIMUM CLEARANCES TO COMBUSTIBLE MATERIALS FOR ALL UNITS	
REAR	0
FRONT	3" (75mm)*
For Service	30" (760mm)
ALL SIDES OF SUPPLY PLENUM	1" (25mm)
SIDES	0
VENT	
Single Wall Vent	6" (150mm)
Type B-1 Double Wall Vent	1" (25mm)
TOP OF FURNACE	6" (150mm)

* 6" with accessory Masonry Chimney drafthood kit installed.

DIMENSIONAL INFORMATION

MODEL	CABINET			SUPPLY AIR		RETURN AIR				GAS CONNECTION		
	A	B	C	D	E	BOTTOM		SIDE		K	L	M
						F	G	H	J			
050BF / 075BF	40	15 ¹ / ₂	28 ¹ / ₂	18 ¹ / ₂	14	23 ¹ / ₈	12 ⁵ / ₈	12 ¹ / ₄	22 ¹ / ₂	28 ¹ / ₄	26	23 ⁷ / ₈
075BH	40	19 ¹ / ₈	28 ¹ / ₂	18 ¹ / ₂	17 ⁵ / ₈	23 ¹ / ₈	14 ³ / ₄	14 ¹ / ₂	22 ¹ / ₂	28 ¹ / ₄	26	23 ⁷ / ₈
100BF, 100BJ	40	19 ¹ / ₈	28 ¹ / ₂	18 ¹ / ₂	17 ⁵ / ₈	23 ¹ / ₈	14 ³ / ₄	14 ¹ / ₂	22 ¹ / ₂	28 ¹ / ₄	26	23 ⁷ / ₈
100BK	40	22 ³ / ₄	28 ¹ / ₂	18 ¹ / ₂	21 ¹ / ₄	23 ¹ / ₈	18 ³ / ₄	14 ¹ / ₂	22 ¹ / ₂	28 ¹ / ₄	26	23 ⁷ / ₈
125BK / 150BK	40	22 ³ / ₄	28 ¹ / ₂	18 ¹ / ₂	21 ¹ / ₄	23 ¹ / ₈	18 ³ / ₄	14 ¹ / ₂	22 ¹ / ₂	28 ¹ / ₄	26	23 ⁷ / ₈
mm Equivalents	40=1016	15 ¹ / ₂ = 394	19 ¹ / ₈ = 486	22 ³ / ₄ = 578	28 ¹ / ₂ = 724	18 ¹ / ₂ = 470	14 = 356	17 ⁵ / ₈ =448				
	21 ¹ / ₄ = 539	23 ¹ / ₈ = 587	12 ⁵ / ₈ = 311	14 ³ / ₄ = 375	18 ³ / ₄ = 476	12 ¹ / ₄ = 311	14 ¹ / ₂ = 368	17 = 432	22 ¹ / ₂ = 572			
	28 ¹ / ₄ = 717	26 = 660	23 ⁷ / ₈ = 606									

Installation Requirements

1. Install furnace level.
2. Install furnace as centralized as practical with respect to the heat distribution system
 - The 150,000 Btuh furnace is manufactured with an air baffle to equalize air flow through the heat exchanger. (See Figure 1).

DO NOT REMOVE THIS BRACKET

3. Install the vent pipes as short as practical. (See **Gas Vent Installation** section).
4. Do **NOT** install furnace directly on carpeting, tile or other combustible material other than wood flooring.
5. Maintain clearance for fire safety and servicing. A front clearance of 30" (760mm) is minimum for access to the burner, controls and filter.
6. Use a raised base if the floor is damp or wet at times.
7. Residential garage installations require:
 - Burners and ignition sources installed at least 18" (457mm) above the floor.
 - Furnace must be located or physically protected from possible damage by a vehicle.

Horizontal Furnace Installation

IMPORTANT

NOTE: Inspect unit rating plate to be certain model number begins with "NTC5, NTN5 or GNJ". This identifies unit as horizontally mountable. If unit does **NOT** bear this designation, you may **NOT** mount this unit horizontally. **Horizontal furnace may not be mounted on its back.**

If you purchased a horizontally mountable furnace, it can be installed horizontally in an attic, basement, crawl space, alcove, or suspended from a ceiling in a basement or utility room in either a right or left airflow position. See **Figure 2**.

The following minimum clearances (**Figure 2**) to combustibles **MUST** be maintained between the furnace and adjacent construction. As shown in **Figure 2**, **ONLY** the corner of the cabinet is allowed to contact the rafters. All other clearances **MUST** be observed as shown in **Figure 1**.

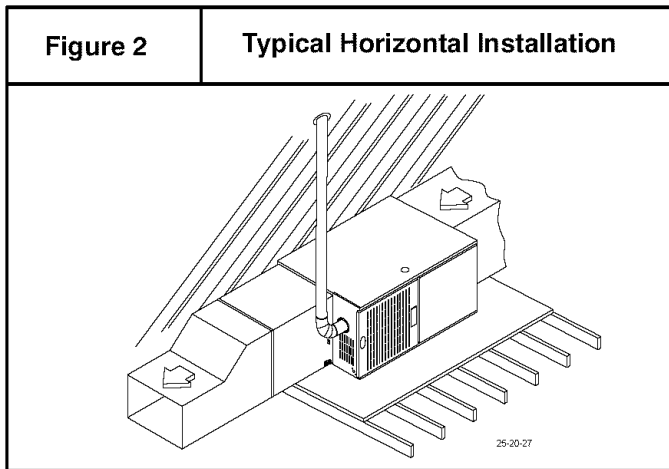

If the furnace is to be suspended from the floor joists in a crawl space or the rafters in an attic, it is necessary to use steel pipe straps or an angle iron frame to attach the furnace. These straps

should be attached to the furnace with sheet metal screws and to the rafters or joists with bolts. The preferred method is to use an angle iron frame bolted to the rafters or joists.

If the furnace is to be installed in a crawl space, consult local codes. A concrete pad 1" to 2" (25 to 50mm) thick is recommended for crawl space installation on the ground.

Thirty inches (30")(760mm) between the front of the furnace and adjacent construction or other appliances **MUST** be maintained for service clearance.

Keep all insulating materials clear from louvered door. Insulating materials may be combustible.

The horizontal furnaces may be installed directly on combustible wood flooring or supports, however it is recommended for further fire protection that cement board or sheet metal is placed between the furnace and the combustible wood floor and extend 12" (300mm) beyond the front of the furnace louver door. (This is a recommendation only, not a requirement).

This furnace **MUST NOT** be installed directly on carpeting or tile or other combustible material other than wood flooring or supports.

Pressure Switch Relocation

If the furnace is installed in a right to left airflow position (left side of furnace facing down), the pressure switch will remain in the same position as installed by the factory (see **Figure 3**). If the furnace is installed in a left to right airflow position (right side of furnace facing down), the pressure switch **MUST** be relocated to the left side of the furnace using the holes provided in the top panel. Position the pressure switch in the same orientation as the original location. To prevent possible kinking of the pressure switch hose, trim the hose to remove excess.

Note: Care **MUST** be taken not to cut the tube too short.

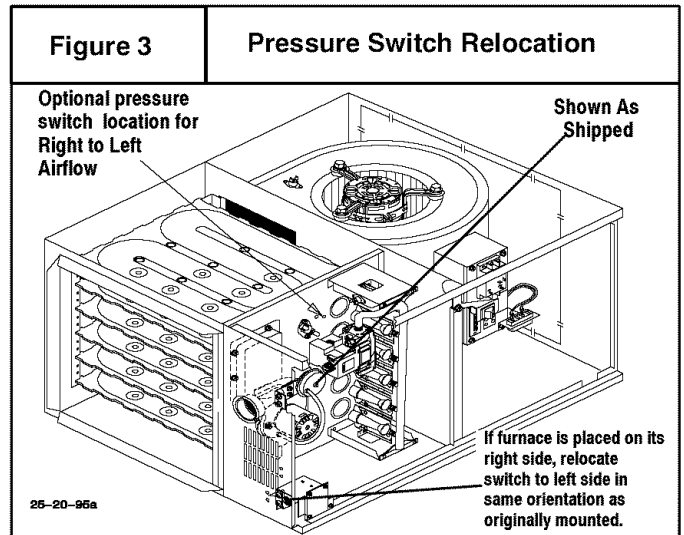

2. Combustion & Ventilation Air

WARNING

Poison carbon monoxide gas hazard.

Use methods described here to provide combustion and ventilation air.

Failure to provide adequate combustion and ventilation air can result in personal injury and/or death.

Furnaces require ventilation openings to provide sufficient air for proper combustion and ventilation of flue gases. All duct or openings for supplying combustion and ventilation air must comply with the gas codes, or in the absence of local codes, the applicable national codes.

When the installation is complete, check that all appliances have adequate combustion air and are venting properly. See *Venting And Combustion Air Check* in this manual.

Contaminated Combustion Air

Installations in certain areas or types of structures will increase the exposure to chemicals or halogens that may harm the furnace. These instances must use only outside air for combustion.

The following areas or types of structures may contain or have exposure to the substances listed below. The installation must be evaluated carefully as it may be necessary to provide outside air for combustion.

- Commercial buildings.
- Buildings with indoor pools.
- Furnaces installed in laundry rooms.
- Furnaces installed in hobby or craft rooms.
- Furnaces installed near chemical storage areas.
- Permanent wave solutions for hair.
- Chlorinated waxes and cleaners.
- Chlorine based swimming pool chemicals.
- Water softening chemicals.
- De-icing salts or chemicals.

- Carbon tetrachloride.
- Halogen type refrigerants.
- Cleaning solvents (such as perchloroethylene).
- Printing inks, paint removers, varnishes, etc..
- Hydrochloric acid.
- Sulfuric Acid.
- Solvent cements and glues.
- Antistatic fabric softeners for clothes dryers.
- Masonry acid washing materials.

Confined Space Installation

NOTE: A confined space is defined as an area with less than 50 cubic feet(1.4m³) per 1,000 BTUH input rating for all gas appliances installed in the area.

Air Openings and Connecting Ducts

1. Total input rating for all gas appliances **MUST** be considered when determining free area of openings.
2. Connect ducts or openings directly to outside.
3. When screens are used to cover openings, the openings **MUST** be no smaller than 1/4" (6mm) mesh.
4. The minimum dimension of rectangular air ducts **MUST NOT** be less than 3" (75mm).
5. When sizing grille or louver, use the free area of opening. If free area is **NOT** stamped or marked on grill or louver, assume a 20% free area for wood and 60% for metal.

Requirements

1. Provide confined space with sufficient air for proper combustion and ventilation of flue gases using horizontal or vertical ducts or openings.
2. **Figure 4** illustrates how to provide combustion and ventilation air. A minimum of two permanent openings, one inlet and one outlet, are required.

Figure 4

Outside Air (This is ONLY a guide. Subject to codes of country having jurisdiction.)

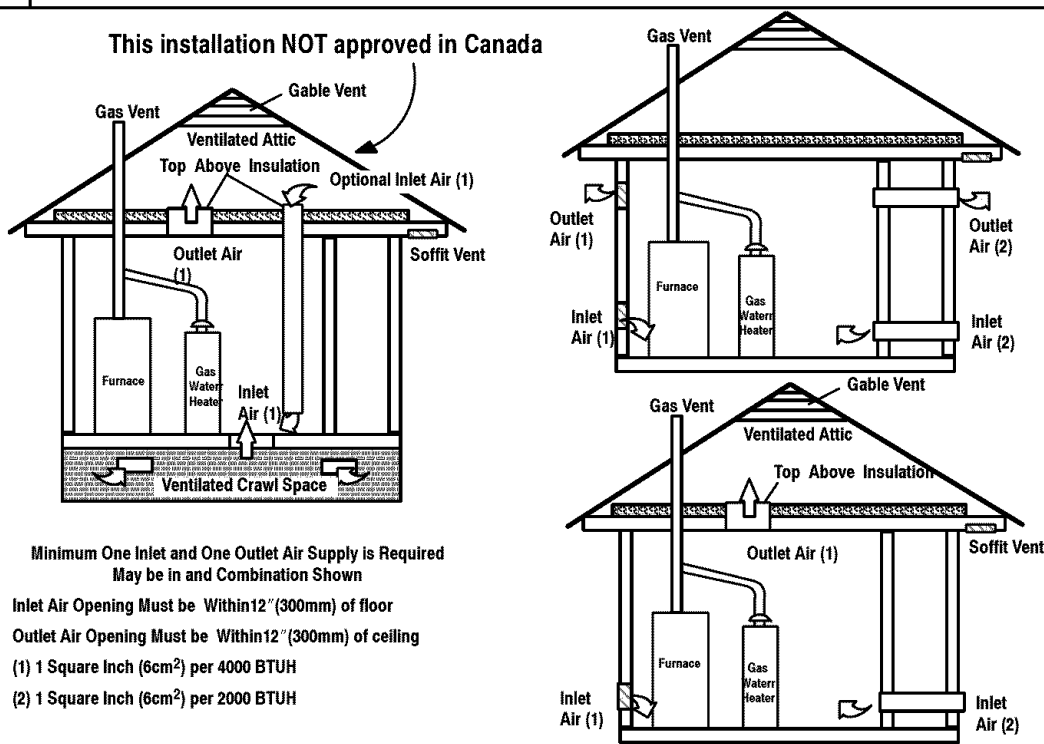

3. One opening **MUST** be within 12" (300mm) of the floor and the second opening within 12" (300mm) of the ceiling.
4. Size openings and ducts per **Table 1**.
5. Horizontal duct openings require 1 square inch (25sq. mm) of free area per 2,000 BTUH of combined input for all gas appliances in area (see **Table 1**).
6. Vertical duct openings or openings directly to outside require 1 square inch (6.5mm³) of free area per 4,000 BTUH for combined input of all gas appliances in area (see **Table 1**).

(16 cm) from the front of the appliance. The opening shall directly communicate with the outdoors or shall communicate through a vertical or horizontal duct to the outdoors or spaces (crawl or attic) that freely communicate with the outdoors, and shall have a minimum free area of:

- 1 sq. in. per 3000 Btu per hr (7cm² per kW) of the total input rating of all equipment located in the enclosure, and
- Not less than the sum of the areas of all vent connectors in the confined space.

Table 1		Free Area	
BTUH Input Rating	Minimum Free Area Required for Each Opening		
	Horizontal Duct (2,000 BTUH)	Vertical Duct or openings to outside (4,000 BTUH)	Round Duct (4,000 BTUH)
50,000	161 cm ² (25 sq. in.)	81 cm ² (12.5 sq. in.)	4"
75,000	242 cm ² (35.5 sq. in.)	121 cm ² (18.75 sq. in.)	5"
100,000	323 cm ² (50 sq. in.)	161 cm ² (25 sq. in.)	6"
125,000	403 cm ² (62.5 sq. in.)	202 cm ² (31.25 sq. in.)	7"
150,000	484 cm ² (71 sq. in.)	242 cm ² (37.5 sq. in.)	7"

EXAMPLE: Determining Free Area
Furnace Water Heater Total Input
 100,000 + 30,000 = (130,000 ÷ 4,000) = 210 cm²
 (32.5 Sq. In.) Vertical
Furnace Water Heater Total Input
 100,000 + 30,000 = (130,000 ÷ 2,000) = 210 cm²
 (65 Sq. In.) Horizontal

Unconfined Space Installation

⚠ WARNING

Poison carbon monoxide gas hazard.

Most homes will require additional air.

An unconfined space or homes with tight construction may not have adequate air infiltration for proper combustion and ventilation of flue gases.

Failure to supply additional air by means of ventilation grilles or ducts could result in personal injury and/or death.

An unconfined space is defined as an area having a minimum volume of 50 cubic feet (1.4m³) per 1,000 Btu total input rating for all gas appliances in area.

Adjoining rooms can be considered part of an unconfined area if there are no doors between rooms.

An attic or crawl space may be considered an unconfined space provided there are adequate ventilation openings directly to outdoors. Openings **MUST** remain open and **NOT** have any means

One permanent opening, commencing within 12" (30 cm) of the top of the enclosure, shall be permitted where the equipment has clearances of at least 1" (2.5 cm) from the sides and back and 6"

of being closed off. Ventilation openings to outdoors **MUST** be at least 1 square inch (25mm²) of free area per 4,000 BTUH of total input rating for all gas appliances in area.

In unconfined spaces, infiltration should be adequate to provide air for combustion, ventilation and dilution of flue gases. However, in buildings with unusually tight construction, additional air **MUST** be provided using the methods described in section titled *Confined Space Installation*:

Unusually tight construction is defined as: Construction with

- 1 Walls and ceilings exposed to the outside have a continuous, sealed vapor barrier. Openings are gasketed or sealed and

3. Gas Vent Installation

⚠ WARNING

Poison carbon monoxide gas, fire and explosion hazard.

Read and follow all instructions in this section.

Failure to properly vent this furnace can result in property damage, personal injury and/or death.

Install the vent in compliance with codes of the country having jurisdiction and the **GAMA** venting tables, local codes or ordinances and these instructions.

These fan assisted combustion furnaces have been classified as Category I appliances which means that they **MUST** operate with a negative vent pressure.

Category I Safe Venting Requirements

NOTE: The following instructions comply with the United States National Fuel Gas Code.

1. If a Category I vent passes through an attic, any concealed space or floor, use **ONLY** Type B or Type L double wall vent pipe. If vent pipe passes through interior wall, use type B vent pipe with ventilated thimble **ONLY**.
2. Do **NOT** vent furnace into any chimney serving an open fireplace or solid fuel burning appliance.
3. Use the same diameter Category I connector or pipe as permitted by the **GAMA** venting tables.
4. Keep vertical Category I vent pipe or vent connector runs as short and direct as possible.
5. Vertical outdoor runs of type B or **ANY** single wall vent pipe below the roof line are **NOT** permitted.
6. Slope all horizontal runs up away from furnace a minimum of $\frac{1}{4}$ " (6mm) per foot.
7. Support all horizontal vent pipe every 6' (2m) using proper clamps and metal straps.
8. Check existing gas vent or chimney to ensure they meet clearances and local codes.
9. The furnace **MUST** be connected to a factory built chimney or vent complying with a recognized standard. **Venting into a masonry or concrete chimney is only permitted as out-**

- 2 Doors and openable windows are weather stripped and
3. Other openings are caulked or sealed. These include joints around window and door frames, between sole plates and floors, between wall-ceiling joints, between wall panels, at penetrations for plumbing, electrical and gas lines, etc.

Ventilation Air

Some provincial codes and local municipalities require ventilation or make-up air be brought into the conditioned space as replacement air. Whichever method is used, the mixed return air temperature across the heat exchanger **MUST** not fall below 60°F (15° c) or flue gases will condense in the heat exchanger. This will shorten the life of the heat exchanger and possibly void your warranty.

lined in the **GAMA** venting tables or *Masonry Chimney* section in these instructions.

⚠ WARNING

Poison carbon monoxide gas hazard.

If this furnace is replacing a previously common-vented furnace, it may be necessary to resize the existing chimney liner or vent to prevent over sizing problems for the other remaining appliances(s). See codes of country having jurisdiction.

Failure to properly vent this furnace or other appliances can result in property damage, personal injury and/or death.

Venting and Combustion Air Check

NOTE: If this installation removes an existing furnace from a venting system serving one or more other appliances, and to make sure there is adequate combustion air for all appliances, **MAKE THE FOLLOWING CHECK.**

1. Seal any unused openings in the venting system.
2. Visually inspect the venting system for proper size and horizontal pitch to ensure there is no blockage or restriction, leakage, corrosion or other deficiencies which could cause an unsafe condition.
3. Insofar as is practical, close all doors and windows and all doors between the space in which the appliance(s) remaining connected to the venting system are located and other spaces of the building.
4. Turn on clothes dryers and any appliance not connected to the venting system. Turn on any exhaust fans, such as range hoods and bathroom exhausts, so they will operate at maximum speed. Do not operate a summer exhaust fan. Close fireplace dampers.
5. Follow the lighting instructions for each appliance being inspected. Adjust thermostat so appliance(s) will operate continuously.
6. Allow 5 minutes of main burner operation, then check for spillage at the draft hood relief opening of each appliance. Use the flame of a match or candle (**Figure 5**).

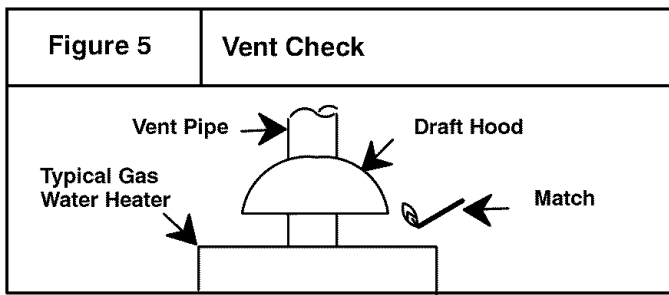

7. After it has been determined that each appliance vents properly, return doors, windows, appliances etc. to their normal condition.
8. If improper venting is observed, the cause **MUST** be corrected.

NOTE: If flame pulls towards draft hood, this indicates sufficient infiltration air.

Venting to Existing Masonry Chimney

NOTE: The tables and notes referred to below are found in the most recent printing of the **GAMA** venting tables.

Dedicated venting of one fan assisted furnace into any masonry chimney is prohibited. The chimney must first be lined with either type B vent sized in accordance with tables 1 or 2 or a listed single wall, metal lining system, sized in accordance with the following: (**Venting as outlined with use of optional masonry chimney kit as applicable.**)

Listed, corrugated metallic chimney liner systems in masonry chimneys shall be sized by using **GAMA** tables 1 or 2 for dedicated venting and **GAMA** tables 3 or 4 for common venting with the maximum capacity reduced by 20% (0.80 X maximum capacity) and the minimum capacity as shown in the applicable table. Corrugated metal vent systems installed with bends or offsets require additional reduction of 10% of the vent capacity for each 90° elbow.

NOTE: Two(2) 45° elbows are equivalent to one (1) 90° elbow.

Combined Venting into a Masonry Chimney

Venting into a masonry or concrete chimney is only permitted as outlined in the GAMA venting tables. Follow all safe venting requirements.

NOTE: See section "Masonry Chimney Venting"

4. Horizontal Venting

Category I Furnaces With External Power Venters

In order to maintain a Category I classification of fan assisted furnaces when vented horizontally with sidewall termination, a power venter is **REQUIRED** to maintain a negative pressure in the venting system. Please consult the Fields Controls Co. or Tjernlund Products, Inc. for power venters certified for use with our furnaces.

Vent Termination

Venting Through a Non-Combustible and Combustible Wall

Consult External Power Venter manufacturer instructions.

CAUTION

It is the responsibility of the installer to properly terminate the vent and provide adequate shielding. This is essential in order to avoid water/ice damage to building, shrubs and walk-ways.

5. Masonry Chimney Venting with Optional Kit

Chimney Inspection

All masonry chimney construction must conform to Standard ANSI/NFPA211 and to any state or local codes applicable. The chimney must be in good condition and a complete investigation must be conducted prior to installation. If the inspection reveals damage or abnormal conditions, make necessary repairs or seek expert help. See "The Chimney Inspection Chart". Measure area of tile-liner and exact height of chimney.

Connector Type

To reduce flue gas heat loss and the chance of condensate problems, the vent connector must be double wall Type B vent.

Venting Restrictions for Chimney Types

Interior Chimney – has no sides exposed to the outside below the roofline. All installations can be single furnace or common vented with another draft hood equipped Category I appliance.

Exterior Chimney – has one or more sides exposed to the outside below the roof line. All installations must be common vented only with another draft hood equipped Category I appliance.

⚠ Caution – failure to follow these guidelines may cause severe property damage.

Optional Masonry Vent Kit Draft Hood Assy. Installation (See Figure 8)

NOTE: These instructions apply to the NTC5, NTN5 & GNJ series furnaces only.

1. Disconnect power and gas supply to furnace.
2. Remove louvered door.
 - a. NTC5, NTN5 & GNJ Series furnaces – Discard louvered door.
3. NTC5, NTN5 & GNJ may be installed upflow or horizontal position per furnace application. When installing NTC5, NTN5 & GNJ furnaces in a horizontal left hand application you will need to mount the pressure switch to the side of the cabinet.
4. NTC5, NTN5 & GNJ series furnaces – Detach pressure switch from top panel by removing two screws. Set aside screws.
5. Detach field connect box from top panel by removing two screws. Set aside screws.

- Remove four screws holding top panel to casing. Remove top panel. Discard top panel. Set screws aside.
- Install draft hood assy. to casing using four screws previously set aside.
- Attach field connect box to draft hood assy. using two screws previously set aside.
- NTC5, NTN5 & GNJ Series furnaces – Attach pressure switch to draft hood assy. using two screws previously set aside.

Vent Limit Switch Wiring (See Figure 6)

- Locate wire harness assy. which is supplied with kit. Attach terminals on one end of wire harness assy. to vent limit switch located on draft hood assy.

- Locate furnace's main limit. Detach wire with insulated terminal from one side of main limit.
- Route wire harness assy. from vent limit switch to main limit. Attach female terminal of wire harness assy. to vacated main limit terminal. Attach male terminal of wire harness assy. to insulated terminal of wire previously detached from main limit.

Completion of Installation

- NTC5, NTN5 & GNJ Series furnaces – Locate louvered door supplied with kit. Install on furnace.
- Refer to installation instructions provided with furnace to put the furnace into operation.

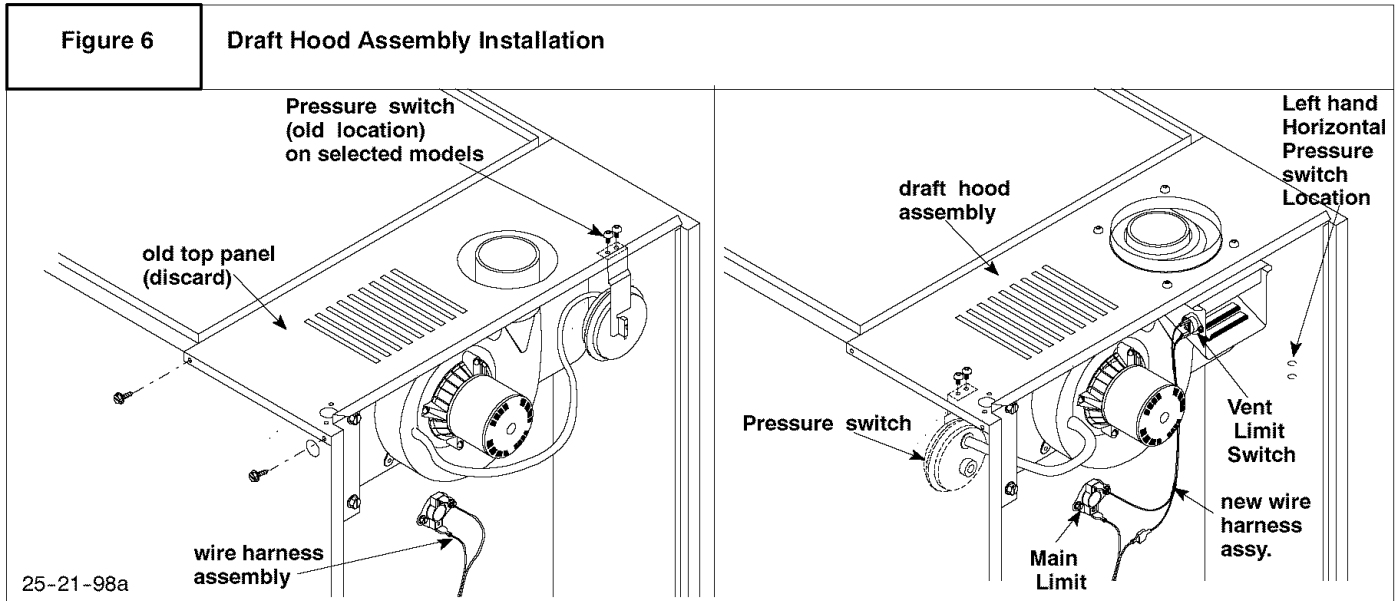

Masonry chimney venting shall be approached as follows: Using **Tables 1** and **2** in the masonry chimney draft hood kit instructions, the NFGC Z223.1-1992 or the GAMA Venting Tables.

6. Gas Supply and Piping

⚠ WARNING

Fire and explosion hazard.

Natural Gas

Models designated for Natural Gas are to be used with Natural Gas ONLY.

Failure to follow these instructions can result in property damage, personal injury and/or death.

Table 2		Gas Pressures			Manifold Pressure
		Supply Pressure			
Gas Type	Recommended	Max.	Min.		
Natural	7 inches (1.7 kPa)	14 inches (3.5 kPa)	4.5 inches (1.1 kPa)	3.5 inches (0.9 kPa)	
Propane	11 inches (2.7 kPa)	14 inches (3.5 kPa)	11 inches (2.7 kPa)	10 inches (2.5 kPa)	

Gas Supply Requirements

- Use only the Type of gas approved for this furnace. See rating plate for approved gas type.
- Gas input must not exceed the rated input shown on the rating plate. Overfiring will result in failure of heat exchanger and cause dangerous operation.
- Do not allow minimum supply pressure to vary downward. Doing so will decrease input to furnace. Refer to **Table 2** for Gas supply and manifold pressures.

Natural Gas Input Rating Check

The gas meter can be used to measure input to furnace. Rating is based on a natural gas BTU content of 1,000 BTU's per cubic foot. Check with gas supplier for actual BTU content.

- Turn **OFF** gas supply to all appliances other than furnace and start furnace.
- Time how many seconds it takes the smallest dial on the gas meter to make one complete revolution. Refer to **Example**. **Note:** If meter uses a 2 cubic foot dial, divide results (seconds) by two.

Example			
Natural Gas BTU Content	No. of Seconds Per Hour	Time Per Cubic Foot in Seconds	BTU Per Hour
1,000	3,600	48	75,000
$1,000 \times 3,600 \div 48 = 75,000 \text{ BTUH}$			

3 Relight all appliances and ensure all pilots are operating.

Orifice Sizing

NOTE: Factory sized orifices for natural and LP gas are listed in the furnace Technical Support manual.

Ensure furnace is equipped with the correct main burner orifices. Refer to **Table 3** & **Table 4** for correct orifice size for a given heating value and specific gravity for natural and propane gas.

Operation Above 2000' Altitude

⚠ WARNING

Fire, Explosion, Poison carbon monoxide gas hazard.

This conversion shall be done by a qualified service agency in accordance with the Manufacturer's instructions and all applicable codes and requirements, or in the absence of local codes, the applicable national codes.

Failure to follow these instructions exactly can result in property damage, personal injury and/or death.

These units may be used at full input rating when installed at altitudes up to 2000'. When installed above 2000', the input must be decreased 4% for each 1000' above sea level. This may be accomplished by a simple adjustment of manifold pressure or an orifice change, or a combination of a pressure adjustment and an orifice change. The changes required depend on the installation altitude and the heating value of the fuel. **TABLE 3** & **TABLE 4** show the proper furnace manifold pressure and gas orifice size to achieve proper performance based on elevation above sea level for both natural gas and propane.

To use the natural gas table, first consult your local gas utility for the heating value of the gas supply. Select the heating value on the vertical border and follow across the table until the appropriate elevation for the installation is reached. The first value in the box at the intersection of the heating value and elevation will be the manifold pressure required. If a gas orifice change is also required, the box is shaded. The required orifice size is shown at the bottom of the table.

Sea Level
High Altitude Input Rate = Nameplate x (Multiplier)
Input Rate

Elevation	High Altitude Multiplier
2000' - 2999'	0.92
3000' - 3999'	0.88
4000' - 4999'	0.84
5000' - 5999'	0.80
6000' - 6999'	0.76
7000' - 8000'	0.72

For installations above 4000', the inlet air restrictor of the combustion air blower **MUST** be changed, whether gas has been derated by the utility or orifices have been changed.

A High Altitude Kit is available which includes restrictors, orifices and installation instructions.

MANIFOLD PRESSURE AND ORIFICE SIZE FOR HIGH ALTITUDE APPLICATIONS

Table 3		NATURAL GAS												
		MEAN ELEVATION FEET ABOVE SEA LEVEL												
HEATING VALUE BTU/CU. FT.	0 to 1999		2000 to 2999		3000 to 3999		4000 to 4999		5000 to 5999		6000 to 6999		7000 to 8000	
	800	3.5" wc	3.5" wc	3.5" wc	3.5" wc	3.5" wc	3.5" wc	3.5" wc	3.5" wc	3.5" wc	3.5" wc	3.2" wc	2.9" wc	2.9" wc
850	3.5" wc	3.5" wc	3.5" wc	3.5" wc	3.5" wc	3.5" wc	3.5" wc	3.5" wc	3.2" wc	2.9" wc	2.9" wc	2.9" wc	2.6" wc	2.6" wc
900	3.5" wc	3.5" wc	3.5" wc	3.4" wc	3.1" wc	2.8" wc	2.5" wc	2.3" wc	2.3" wc	2.3" wc	2.3" wc	2.3" wc	2.3" wc	2.3" wc
950	3.5" wc	3.3" wc	3.1" wc	2.8" wc	2.5" wc	2.3" wc	2.3" wc	2.3" wc	2.3" wc	2.3" wc	2.3" wc	2.3" wc	2.3" wc	3.5" wc
1000	3.5" wc	3.0" wc	2.8" wc	2.5" wc	2.3" wc	2.3" wc	2.3" wc	2.3" wc	2.3" wc	2.3" wc	2.3" wc	2.3" wc	2.3" wc	3.1" wc
1050	3.2" wc	2.7" wc	2.5" wc	2.3" wc	2.3" wc	2.3" wc	2.3" wc	2.3" wc	2.3" wc	2.3" wc	2.3" wc	2.3" wc	2.3" wc	2.8" wc
1100	2.9" wc	2.5" wc	2.3" wc	2.3" wc	2.3" wc	2.3" wc	2.3" wc	2.3" wc	2.3" wc	2.3" wc	2.3" wc	2.3" wc	2.3" wc	2.6" wc
Orifice Size	#42	#42	#42	#42	#42	#42	#42	#42	#42	#42	#42	#42	#42	#42

SHADED AREA REQUIRES ORIFICE CHANGE. NO SHADING INDICATES MANIFOLD PRESSURE CHANGE ONLY.

Table 4		PROPANE												
		MEAN ELEVATION FEET ABOVE SEA LEVEL												
HEATING VALUE BTU/CU. FT.	0 to 1999		2000 to 2999		3000 to 3999		4000 to 4999		5000 to 5999		6000 to 6999		7000 to 8000	
	2500	10.0" wc	10.0" wc	9.4" wc	10.0" wc	9.8" wc	8.8" wc	7.9" wc	7.9" wc	7.9" wc	7.9" wc	7.9" wc	7.9" wc	7.9" wc
Orifice Size	#54	#54	#54	#54	#54	#54	#54	#54	#54	#54	#54	#54	#54	#54

NOTE: NATURAL GAS DATA BASED ON 0.60 SPECIFIC GRAVITY. PROPANE DATA BASED ON 1.53 SPECIFIC GRAVITY. FOR FUELS WITH DIFFERENT SPECIFIC GRAVITY CONSULT THE LATEST EDITION OF THE NATIONAL FUEL GAS CODE ANSI Z223.1 and CAN B149.

Changing Orifices

1. After disconnecting power and gas supply to the furnace, remove the access door, exposing gas valve and burner compartment.
2. Disconnect gas line and pilot tubing from gas valve so manifold can be removed.
3. Disconnect wiring at gas valve. Be sure to note the proper location of any and all electrical wiring disconnected.
4. Remove the four (4) screws holding the manifold and gas valve to the manifold supports. Do not discard any screws. See **Figure 7**.

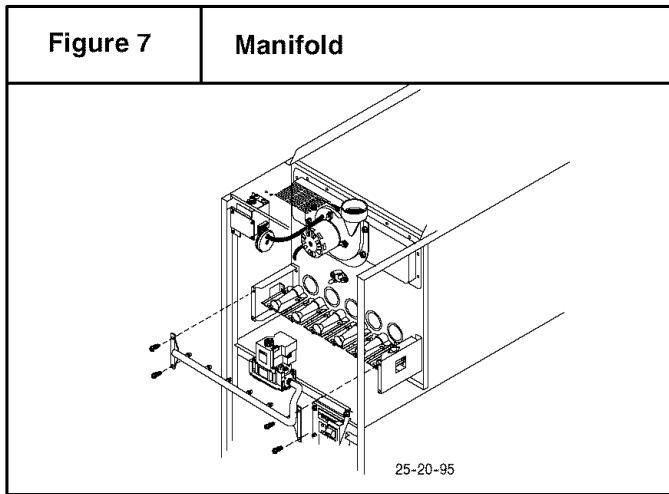

5. Carefully remove the manifold assembly.
6. Remove the orifices from the manifold and replace them with proper sized orifices. See **Figure 8**.
7. Tighten orifices so there is $1\frac{1}{8}$ " from the face of the orifice to the back side of the manifold. See **Figure 8**.

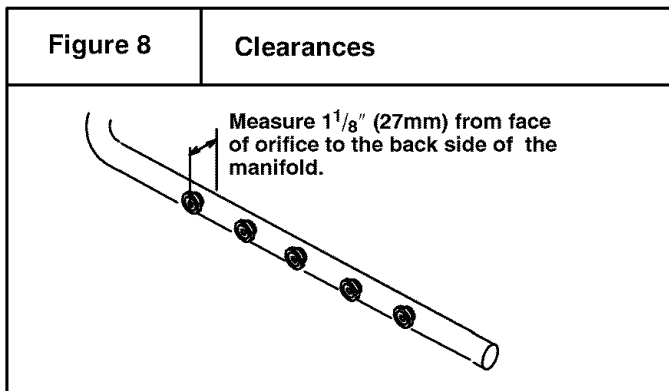

8. Reassemble all parts in reverse order as removed. Be sure to engage the main burner orifices in the proper opening in the burners.
9. After reassembling, turn gas on and check all joints for gas leaks using a soapy solution. All leaks must be repaired immediately.

Gas Piping Requirements

1. Install gas piping in accordance with local codes, or in the absence of local codes, the applicable national codes.
2. It is recommended that a manual shutoff valve be installed in the gas supply line outside the unit. Locate valve as close to the furnace as possible where it is readily accessible. Refer to **Figure 9**.

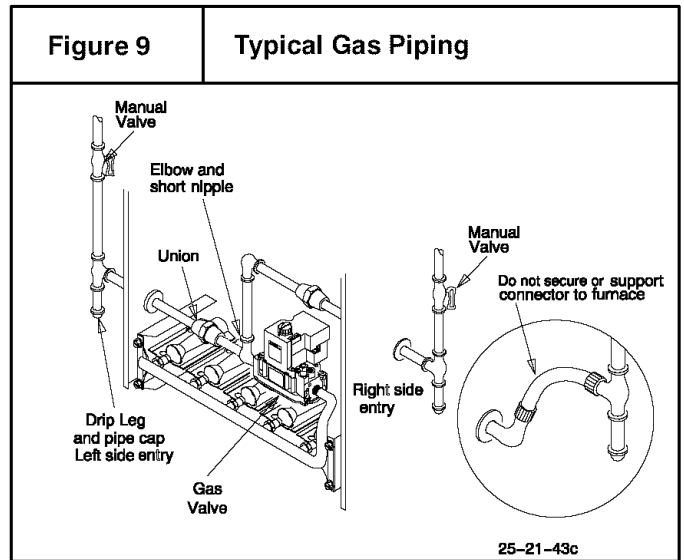

3. Use black iron or steel pipe and fittings or other pipe approved by local code.
4. Use pipe thread compound which is resistant to natural and LP gases.
5. Install a drip leg no less than 3" long to trap dirt and moisture before it can enter gas valve.
6. Provide a $\frac{1}{8}$ " inch plug for test gauge connection immediately up stream of gas supply connection to furnace.
7. Use two pipe wrenches when making connections to prevent gas valve from turning.
8. Flexible corrugated metal gas connector may **NOT** be used inside the furnace or be secured or supported by the furnace or ductwork.
9. Properly size gas pipe to handle combined appliance load or run gas pipe directly from gas meter or LP gas regulator.
10. Install correct pipe size for run length and furnace rating.
11. Measure pipe length from gas meter or LP second stage regulator.

! WARNING	
Fire or explosion hazard.	
Gas connector must be properly installed, cannot go through the side of the furnace, and can not be used inside the furnace.	
Failure to properly install gas connector can result in property damage, bodily injury and/or death.	

Additional LP Piping Requirements

- Have a licensed LP gas dealer make all connections at storage tank and check all connections from tank to furnace.

- If copper tubing is used, it **MUST** comply with limitation set in Local Codes, or in the absence of local codes, the gas codes of the country having jurisdiction. See Appendix.
- Two-stage regulation of LP gas is recommended.

Final Check

- Test all pipe for leaks.
- If orifices were changed, make sure they are checked for leaks.
- During pressure testing of gas piping system, observe the following:
 - a. If test pressure does not exceed 1/2" PSIG, isolate the furnace by closing its individual manual shutoff valve.
 - b. If test pressure exceeds 1/2" PSIG, the furnace and its individual shutoff valve must be disconnected from the gas supply system.
- To check for leaks apply soap suds or a liquid detergent to each joint. Bubbles forming indicate a leak.

- Do not use an open flame to test for gas leaks. Fire or explosion could occur.
- Correct even the smallest leak at once.

⚠ WARNING

Fire or explosion hazard.

Liquid petroleum (LP) gas is heavier than air and will settle and remain in low areas and open depressions.

Thoroughly ventilate area and dissipate gas. Do NOT use a match or open flame to test for leaks, or attempt to start up furnace before thoroughly ventilating area.

An open flame or spark can result in property damage, personal injury and/or death.

7. Electrical Wiring

Power Supply Wiring

The furnace **MUST** be electrically wired and grounded in accordance with local codes, or in the absence of local codes, the applicable national codes.

Field wiring connections must be made inside the furnace connection box. A suitable strain relief should be used at the point the wires exit the furnace casing.

Copper conductors shall be used. Line voltage wires should be sized for the input amps stated on the rating plate. Furnace should be connected to its own separate circuit.

Thermostat

Thermostat location has an important effect on the operation of the unit. Follow instructions included with thermostat for correct mounting and wiring.

Low voltage connections to furnace must be made on terminal board to fan control.

Set thermostat heat anticipator in accordance with the *Technical Support Manual*.

Optional Equipment

All wiring from furnace to optional equipment **MUST** conform to local codes or, in the absence of local codes, the applicable national codes. Install wiring in accordance with manufacturer's instructions.

Humidifier/Electronic Air Cleaner

The furnace is wired for humidifier and/or electronic air cleaner connection.

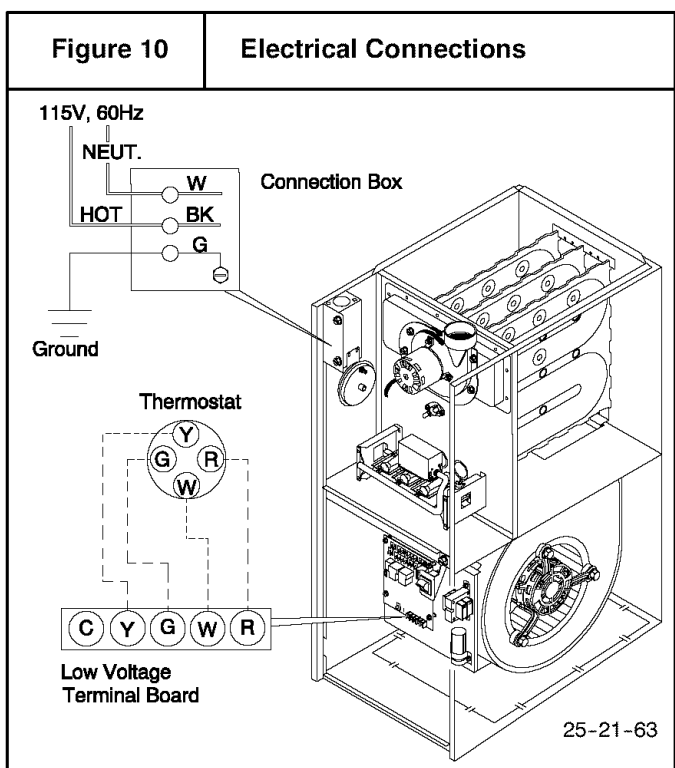

CAUTION

Do NOT exceed 115V/0.8 amp. maximum current load for both the EAC terminal and the HUM terminal combined.

NOTE: The humidifier will be powered when the furnace is fired and the circulating air blower comes on. The electronic air cleaner will be powered anytime the thermostat calls for air movement. However, the electronic air cleaner is **NOT** energized during continuous fan operation controlled by the electronic fan control.

8. Ductwork and Filter

⚠ **WARNING**

Poison carbon monoxide gas hazard.

Do **NOT** draw return air from inside a closet or utility room where furnace is located. Return air duct **MUST** be sealed to furnace casing.

Failure to properly seal duct can result in personal injury and/or death.

Duct Connections

This furnace may be installed in only a bottom or side return application. Return air through the back of the unit is **NOT** allowed.

Side connections can be made by cutting out the embossed area shown in **Figure 11**.

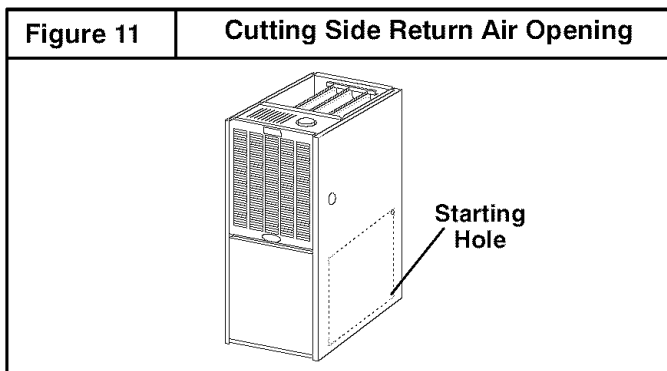

Bottom returns can be made by removing the knockout panel in the furnace base. Do **NOT** remove knock-out except for a bottom return.

Duct Design

Design and install air distribution system to comply with Air Conditioning Contractors of America manuals or other approved methods that conform to local codes and good trade practices.

When the furnace is located in an area near or adjacent to the living area, the system should be carefully designed with returns to minimize noise transmission through the return air grille. Any blower moving a high volume of air will produce audible noise which could be objectionable when the unit is located very close to a living area. It is often advisable to route the return air ducts under the floor or through the attic.

- Refer to furnace **Technical Support Manual** (Blower Data) for air flow information.
- Size ductwork to handle air flow for heating and air conditioning.

Duct Installation Requirements

- When furnace supply ducts carry air outside furnace area, seal return air duct to furnace casing and terminate duct outside furnace space.
- When a refrigeration coil is used in conjunction with this unit, it must be installed on the discharge side of the unit to avoid condensation on the heat exchanger.

- If separate evaporator and blower unit is used, install good sealing dampers for air flow control. Chilled air going through the furnace could cause condensation and shorten furnace life. Dampers (purchased locally) can be either automatic or manual. Manually operated dampers **MUST** be equipped with a means to prevent furnace or air conditioning operation unless damper is in the full heat or cool position.

⚠ **WARNING**

Poison carbon monoxide gas hazard.

Cool air passing over heat exchanger can cause condensate to form resulting in heat exchanger failure.

This could result in personal injury and/or death.

- Installation of locking-type dampers are recommended in all branches, or in individual ducts to balance system's air flow.
- Non-combustible, flexible duct connectors are recommended for return and supply connections to furnace.
- If air return grille is located close to the fan inlet, install at least one, 90 degree air turn between fan and inlet grille to reduce noise.
- Ductwork installed in attic, or exposed to outside temperatures require 2" of insulation with outdoor type vapor barrier.
- Ductwork installed in an indoor unconditioned space requires a minimum of 1" of insulation with indoor type vapor barrier.

Inspection Panel

A removable access panel should be provided in the outlet duct when the furnace is installed without a cooling coil. This will allow smoke or reflected light to be observable inside the casing to indicate the presence of leaks in the heat exchanger. This access cover shall be attached in such a manner as to prevent air leaks.

Filters

The furnaces, with 1600 or less CFM rating, are supplied with a 16" x 25" high velocity filter and rack. On these models, the supplied filter rack may be mounted internally for bottom return or externally for side return.

The furnaces with greater than 1600 CFM requires that both left and right side returns are used in side return applications. Two 16" x 25" high velocity filters and racks are provided with furnace. Filter racks must be mounted externally. If return air must be on one side only, an optional 20" x 25" filter standoff rack kits can be used. For bottom return, an optional 20" x 25" filter rack kit can be mounted internally.

NOTE: All California (NOx) 5 ton models come with a 20" x 25" bottom return filter.

Filters Rack Installation

Side Return

Center the filter rack on the side panel, flush with the bottom edge of the furnace. Mark the fastening holes. Drill the fastening holes in the side panel and fasten the filter rack in place with sheet metal screws. See **Figure 12**.

CAUTION

If filters are only suitable for heating application, advise homeowner that filter size may need to be increased if air conditioning is added.

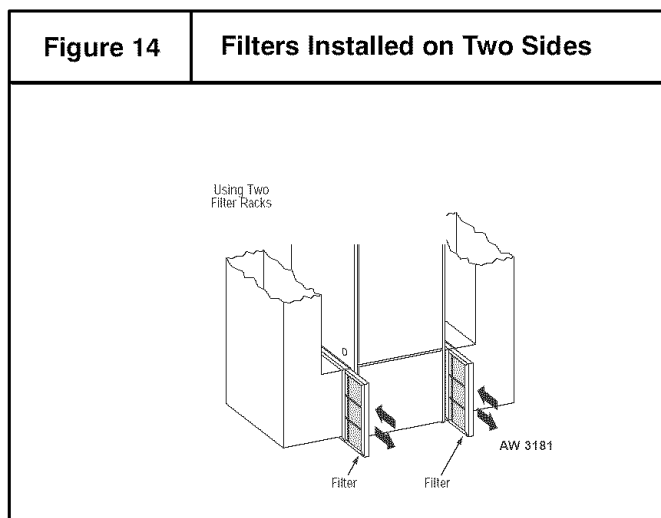
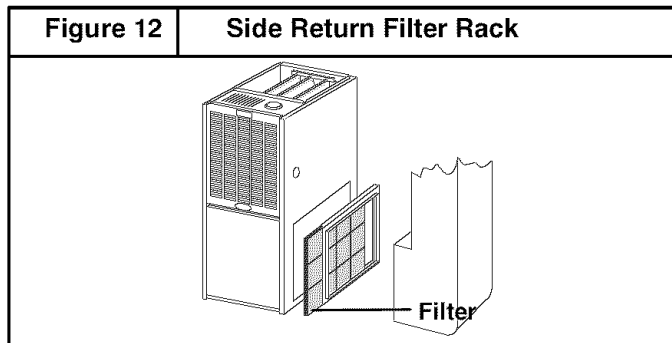

Bottom Return

When installing a bottom mounted filter rack, slide the two side filter clips to the back of the furnace **BEFORE** installing. This will allow the rack to clear the front raised edge of the furnace. Insert rack into side clips first and push rack back until it is fully engaged into back clip. When rack is in place, slide clips back into place midway on rack as shown in **Figure 13**.

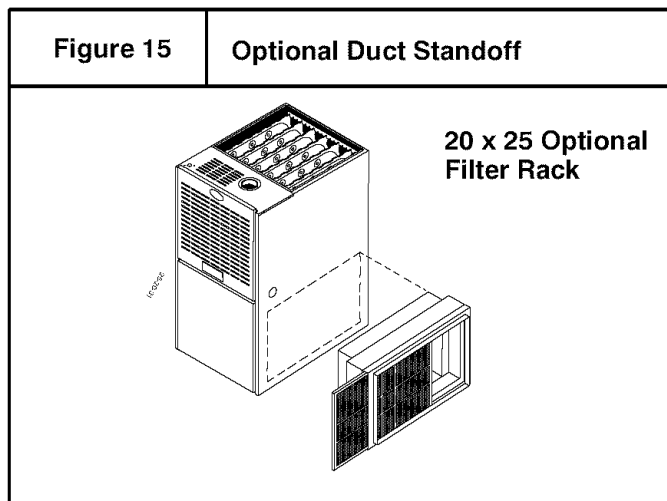
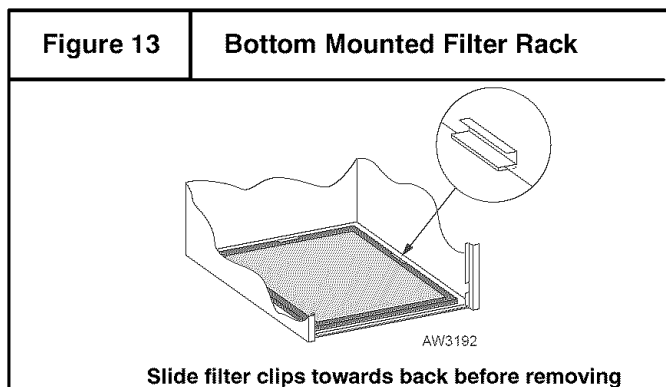

9. Checks and Adjustments

Startup

NOTE: Refer to startup procedures in the *Users Information Manual*.

CAUTION

If any sparks, odors or unusual noises occur, immediately shut OFF power to furnace. Check for wiring errors or obstruction to blower.

Gas Supply Pressure

Gas supply pressure should be within minimum and maximum values listed on rating plate. Pressures are usually set by gas suppliers.

Manifold Gas Pressure Adjustment

NOTE: Make adjustment to manifold pressure with burners operating.

⚠ WARNING

Fire or explosion hazard.

Turn OFF gas at shut off before connecting U-tube manometer.

Failure to turn OFF gas at shut off before connecting U-tube manometer can result in personal injury and/or death.

1. With gas **OFF**, Connect U-Tube manometer to tapped opening on gas valve. Use manometer with a 0 to min. 12" water column range.
2. Turn gas **ON** and remove adjustment screw cover on gas valve. Turn counterclockwise to decrease pressure and clockwise to increase.

NOTE: Adjustment screw cover **MUST** be placed on gas valve before reading manifold pressure and operating furnace.

3. For altitudes up to 2000', set pressure to value shown in **Table 2**, $\pm 0.3"$ (8mm) water column. For altitudes up to 2000' to 8000', see Section 6 for correct pressure valve.

Adjust Pilot Burner

The furnace has a pilot flame to light the main burner. The flame should surround $\frac{3}{8}$ " to $\frac{1}{2}$ " of the thermocouple. See **Figure 16**. To adjust, remove cap from pilot adjusting screw on gas valve. Turn screw counterclockwise to increase or clockwise to decrease flame as required. Replace cap for adjusting screw.

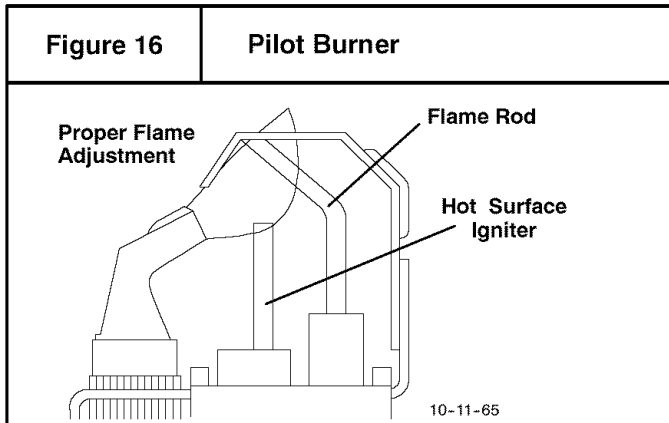

Main Burner Flame Check

Allow the furnace to run approximately 10 minutes then inspect the main burner and pilot flames. See **Figure 17**.

Check for the following (**Figure 17**):

- Stable and blue flames. Dust may cause orange tips or wisps of yellow, but flames **MUST NOT** have solid, yellow tips.
- Flames extending directly from burner into heat exchanger.
- Flames do **NOT** touch sides of heat exchanger

If any problems with main burner flames are noted, it may be necessary to adjust gas pressures, or check for drafts.

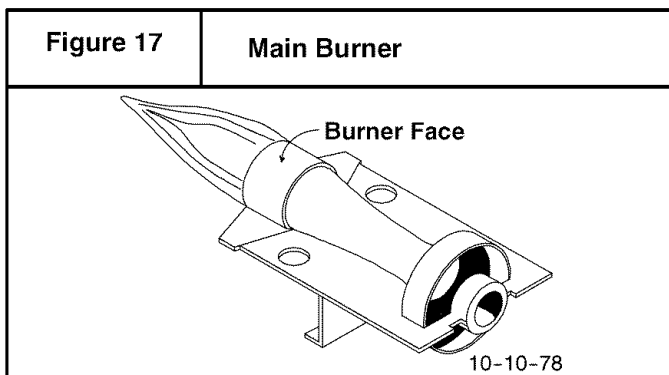

Temperature Rise Check

The blower speed **MUST** be set to give the correct air temperature rise through the furnace as marked on the rating plate. Temperature rise is the difference between supply and return air temperatures.

To check temperature rise, use the following procedure:

1. Place thermometers in supply and return air registers as close to furnace as possible, avoiding direct radiant heat from heat exchangers.

2. Operate furnace continuously for 15 minutes with all registers and duct dampers open.
3. Take reading and compare with range specified on rating plate.
4. If the correct amount of temperature rise is **NOT** obtained, it may be necessary to change blower speed. A higher blower speed will lower the temperature rise. A lower blower speed will increase the temperature rise.

Changing Blower Speed

! WARNING

Electrical shock hazard.

Turn OFF power to furnace before changing speed taps.

Failure to do so can result in personal injury and/or death.

NOTE: The speed taps that the manufacture sets from the factory for this product are based on a nominal 400 CFM per ton cooling and the basic mid range on the temperature rise for heating.

Since the manufacturer cannot establish the static pressure that will be applied to the unit, it is the responsibility of the installer dealer/contractor to select the proper speed taps for the application when the unit is installed.

If it is necessary to change speeds, refer to steps below.

1. Refer to *Furnace Wiring Diagram* for location of the heating and cooling speed taps located on the electronic fan control as well as location of unused blower motor speed leads. Use the chart (**Table 5**) to determine the blower motor speed settings.

Table 5		Blower Speed Chart	
Wire Color		Motor Speed	
Black		High	
Orange*		Med-High	
Blue		Medium	
Red		Low	

* Med-High speed may not be provided on all models.

2. Change the heat or cool blower motor speed by removing the motor lead from the "Heat" or "Cool" terminal and replace it with the desired motor speed lead from the "Unused Motor Lead" location. Connect the wire previously removed from the "Heat" or "Cool" terminal to the vacated "Unused Motor Lead" terminal.
3. If the same speed must be used for both heating and cooling, remove the undesired motor speed lead from the "Heat" or "Cool" terminal and connect that lead to the open terminal at "Unused Motor Lead" location. Attach a jumper between the "Heat" and "Cool" terminals and the remaining motor speed lead.

Note: When using the same speed on motors with (4) speed leads, it will be necessary to tape off the terminal of the motor speed lead removed from the "Heat" or "Cool" terminal with electrical tape since an open terminal will not be available at the "Unused Motor Lead" location.

Continuous Fan Operation

A terminal is provided on the electronic fan control located in the circulating blower compartment for operation of the continuous fan option. This connection is intended for the low speed motor tap, and has a lower contact rating (8 amps) than the heat and cool taps. When the low speed blower lead is connected to this terminal, this will provide low speed blower operation whenever the other two speeds (**Heat** or **Cool**) are not energized.

Thoroughly check the system after modification to ensure the proper operation of the circulating air blower in all modes of operation.

Separate speed selections for Heat, Cool, and Continuous Fan

Connect low speed lead from circulating motor to the "**Cont.**" terminal at the electronic fan control. The appropriate motor leads should already be connected to the "**Heat**" and "**Cool**" terminals.

Heating and Continuous Blower Speed the Same

If it is necessary to operate the heating speed and continuous blower speed using the same blower speed, connect a jumper between the "**Heat**" and "**Cont.**" terminals on the electronic fan control.

Note: There should be only **ONE** motor lead going to the "**Heat**" and "**Cont.**" terminals.

10. Furnace Maintenance

CAUTION

It is recommended that the furnace be inspected and serviced on an annual basis (before the heating season) by a qualified service technician.

See "*User's Information Manual*".

Pressure Switch

During regular yearly maintenance check for cracks in any tubes on the pressure switch.