



Side-by-Side Refrigerator

Use & Care Guide

Refrigerador de Dos Puertas

Guía de Uso y Cuidado, página 37

Réfrigérateur à compartiment juxtaposés

Guide d'utilisation et d'entretien, page 75

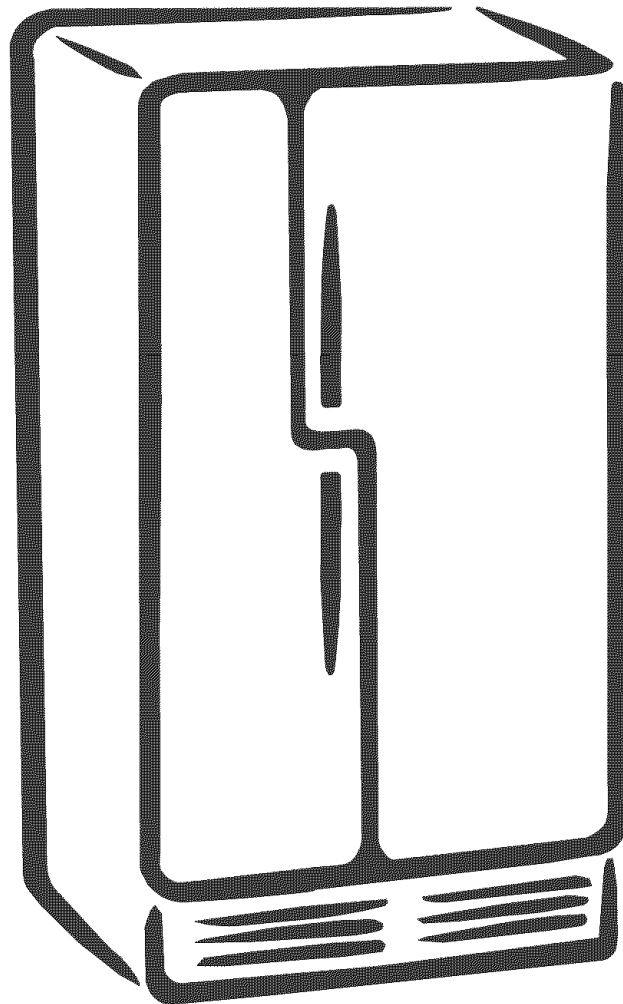

596.5565200

596.5565300

596.5565400

596.5565900











596.5566200

596.5566300

596.5566400

596.5566900

Contents

	Important Safety Instructions	3-4
	Warranty and Protection Agreements	5-6
	Installation	7-11
	Location	Door and Hinge Removal
	Measuring the Opening	Replacing the Doors
	Transporting Your Refrigerator	Handles
	Leveling	Connecting the Water Supply
	Temperature Controls	12-14
	Temperature Control	
	Advanced Temperature Control	
	Fresh Food Features	15-16
	Shelves	
	Storage Drawers	
	Accessories	
	Freezer Features	17
	Shelves and Baskets	
	Door Storage	
	Ice and Water	18-20
	Automatic Ice Maker	Water Dispenser Operation
	Dispenser Features	Dispenser Control
	Water Filter	21-23
	Removal and Installation	Water Treatment Device Certificate
	General Use Conditions	
	Food Storage Tips	24-26
	Fresh Food Storage	
	Frozen Food Storage	
	Food Storage Chart	
	Care and Cleaning	27-30
	Refrigerator Cleaning Chart	Replacing Light Bulbs
	Removing Odors From Refrigerator	Preparing for Vacation
	Energy Saving Tips	Preparing to Move
	Operating Sounds	31
	Troubleshooting	32-35
	Guía de Uso y Cuidado	37
	Guide d'utilisation et d'entretien	75



Important Safety Instructions

Installer: Please leave this guide with this appliance.

Consumer: Please read and keep this Use & Care Guide for future reference, it provides the proper use and maintenance information.

In our continuing effort to improve the quality and performance of our appliances, it may be necessary to make changes to the appliance without revising this guide.

What You Need to Know About Safety Instructions

Warning and Important Safety Instructions appearing in this guide are not meant to cover all possible conditions and situations that may occur. Common sense, caution and care must be exercised when installing, maintaining or operating appliance.

Recognize Safety Symbols, Words, Labels

DANGER

DANGER – Immediate hazards which **WILL** result in severe personal injury or death.

WARNING

WARNING – Hazards or unsafe practices which **COULD** result in severe personal injury or death.

CAUTION

CAUTION – Hazards or unsafe practices which **COULD** result in minor personal injury or property damage.

DANGER

To reduce risk of injury or death, follow basic precautions, including the following:

IMPORTANT: Child entrapment and suffocation are not problems of the past. Junked or abandoned refrigerators are still dangerous – even if they sit out for “just a few days.” If you are getting rid of your old refrigerator, please follow the instructions below to help prevent accidents.

Before you throw away your old refrigerator or freezer:

- Take off the doors.
- Leave the shelves in place so children may not easily climb inside.

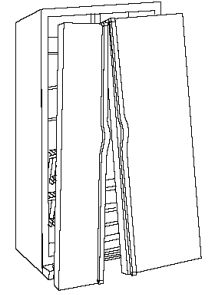

This appliance is equipped with a three-prong grounding plug for your protection against possible electrical shock hazards. It must be plugged into a grounding receptacle. Where a standard two-prong wall receptacle is encountered, it is the personal responsibility and obligation of the customer to have it replaced with a properly grounded three-prong wall receptacle. Do not under any circumstances, cut or remove the third (ground) prong from the power cord. Do not use an adapter plug.

Power supply cord with three-prong grounding plug

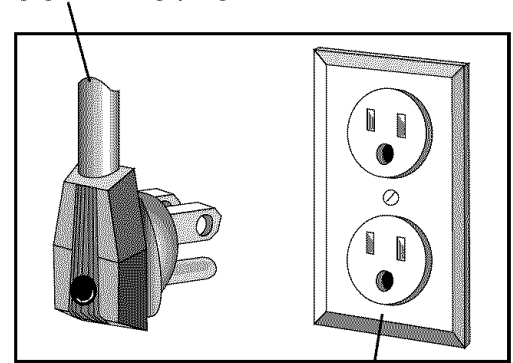

Grounding type wall receptacle



Important Safety Instructions

⚠ WARNING

To reduce risk of fire, electric shock, serious injury or death when using your refrigerator, follow these basic precautions:

1. Read all instructions before using the refrigerator.
2. Observe all local codes and ordinances.
3. Be sure to follow grounding instructions.
4. Check with a qualified electrician if you are not sure this appliance is properly grounded.
5. Do not ground to a gas line.
6. Do not ground to a cold-water pipe.
7. Refrigerator is designed to operate on a separate 115 volt, 15 amp., 60 cycle line.
8. Do not modify plug on power cord. If plug does not fit electrical outlet, have proper outlet installed by a qualified electrician.
9. Do not use a two-prong adapter, extension cord or power strip.
10. Do not remove warning tag from power cord.
11. Do not tamper with refrigerator controls.
12. Do not service or replace any part of refrigerator unless specifically recommended in Use & Care Guide or published user-repair instructions. Do not attempt service if instructions are not understood or if they are beyond personal skill level.
13. Always disconnect refrigerator from electrical supply before attempting any service. Disconnect power cord by grasping the plug, not the cord.
14. Install refrigerator according to Installation Instructions. All connections for water, electrical power and grounding must comply with local codes and be made by licensed personnel when required.
15. Keep your refrigerator in good condition. Bumping or dropping refrigerator can damage refrigerator or cause refrigerator to malfunction or leak. If damage occurs, have refrigerator checked by qualified service technician.
16. Replace worn power cords and/or loose plugs.
17. Always read and follow manufacturer's storage and ideal environment instructions for items being stored in refrigerator.
18. Your refrigerator should not be operated in the presence of explosive fumes.
19. Children should not climb, hang or stand on any part of the refrigerator.
20. Clean up spills or water leakage associated with water installation.

SAVE THESE INSTRUCTIONS



Warranty

Warranty

One Year Full Warranty on Refrigerator

For one year from the date of purchase, when this refrigerator is operated and maintained according to the instructions supplied with it, Sears will repair this refrigerator, free of charge, if defective in material or workmanship. This one year time period does not include the refrigerator water filter cartridge (if equipped), which is an expendable part warranted for only 30 days (see below).

Five Year Full Warranty on Sealed Refrigeration System

For five years from the date of purchase, when this refrigerator is operated and maintained according to instructions supplied with it, Sears will repair the sealed system (consisting of refrigerant, connecting tubing and compressor) free of charge, if defective in material or workmanship.

30 Day Full Warranty on Water Filter Cartridge (if equipped)

For thirty days from the date of purchase, Sears will replace the refrigerator water filter cartridge if it is defective in material or workmanship.

All above warranty coverage applies only to refrigerators which are used for storage of food for private household purposes.

Warranty service is available in the United States or Canada by contacting Sears at 1-800-4-MY-HOME® (1-800-469-4663).

This warranty applies only while this product is in use in the United States or Canada.

This warranty gives you specific legal rights. You may also have other rights, which vary from state to state or province to province.

Sears, Roebuck and Co.
Dept. 817WA
Hoffman Estates, IL 60179

Sears Canada, Inc.,
Toronto, Ontario
Canada M5B 2B8

Reverse Osmosis Water Systems

- Some Reverse Osmosis home water systems cause low water pressure. Low water pressure can affect the water and ice dispensing system by causing small or hollow ice cubes and slow water flow from the dispenser. Service problems related to the home's Reverse Osmosis water system are not covered by the warranty.

Product Record

In the space below record the model and serial numbers and purchase date of your refrigerator. You will find the model and serial number sticker inside the refrigerator section on the left wall.

Model Number: 596. _____

Serial Number: _____

Purchase Date: _____

Keep this booklet and your Sears sales receipt in a safe place for future reference.



Protection Agreements

In the U.S.A.

Master Protection Agreements

Congratulations on making a smart purchase. Your new Kenmore® product is designed and manufactured for years of dependable operation. But like all products, it may require preventive maintenance or repair from time to time. That's when having a Master Protection Agreement can save you money and aggravation.

Purchase a Master Protection Agreement now and protect yourself from unexpected hassle and expense.

The Master Protection Agreement also helps extend the life of your new product. Here's what's included in the Agreement:

- ✓ **Expert service** by our 12,000 professional repair specialists
- ✓ **Unlimited service and no charge** for parts and labor on all covered repairs
- ✓ **"No-lemon" guarantee** – replacement of your covered product if four or more product failures occur within twelve months
- ✓ **Product replacement** if your covered product can't be fixed
- ✓ **Annual Preventive Maintenance Check** at your request – no extra charge
- ✓ **Fast help by phone** – phone support from a Sears technician on products requiring in-home repair, plus convenient repair scheduling
- ✓ **Power surge protection** against electrical damage due to power fluctuations
- ✓ **Rental reimbursement** if repair of your covered product takes longer than promised

Once you purchase the Agreement, a simple phone call is all that it takes for you to schedule service. You can call anytime day or night, or schedule a service appointment online.

Sears has over 12,000 professional repair specialists, who have access to over 4.5 million quality parts and accessories. That's the kind of professionalism you can count on to help prolong the life of your new

purchase for years to come. Purchase your Master Protection Agreement today!

Some limitations and exclusions apply. For prices and additional information, call 1-800-827-6655.

Sears Installation Service

For Sears professional installation of home appliances, garage door openers, water heaters, and other major home items, in the U.S.A. call **1-800-4-MY-HOME®** (1-800-469-4663).

In Canada

Maintenance Agreements

Your purchase has added value because you can depend on Sears HomeCentral® for service. With over 2,400 Service Technicians and more than a million parts and accessories, we have the tools, parts, knowledge and skills to back our pledge: We Service What We Sell.

Your Kenmore® product is designed, manufactured and tested to provide years of dependable operation. But like all products, it may require service from time to time. The Sears Maintenance Agreement offers you an outstanding service program, affordably priced.

Sears Maintenance Agreement

- Is your way to buy tomorrow's service at today's price
- Eliminates repair bills resulting from normal wear and tear
- Provides phone support from a Sears technician on products requiring in-home repair
- Even if you don't need repairs, provides an annual Preventive Maintenance Check, at your request, to ensure that your product is in proper running condition

Some limitations apply. For information about Sears Canada Maintenance Agreements, call 1-800-361-6665.



Installation

Your refrigerator was packed carefully for shipment. Remove and discard shelf packaging and tape. Do not remove the serial plate.

Location

- Do not install refrigerator near oven, radiator or other heat source. If not possible, shield refrigerator with cabinet material.
- Do not install where temperature falls below 55° F (13° C) or rises above 110° F (43° C). Malfunction may occur at this temperature.
- **Refrigerator is designed for indoor household application only.**

Measuring the Opening

When installing your refrigerator, allow ½" space at top and ½" space behind machine compartment cover (located in the rear) for proper air circulation. If the refrigerator is placed with the door hinge side against a wall, you may want to allow additional space so the door can be opened wider.

Subflooring or floor coverings (i.e. carpet, tile, wood floors, rugs) may make your opening smaller than anticipated.

Some clearance may be gained by using the leveling procedure under *Leveling*, pg. 8.

IMPORTANT: If refrigerator is to be installed into a recess where the top of the refrigerator is completely covered, use dimensions from floor to top of hinge cap to verify proper clearance.

Transporting Your Refrigerator

- **NEVER** transport refrigerator on its side. If an upright position is not possible, lay refrigerator on its back. Allow refrigerator to sit upright for approximately 30 minutes before plugging it in to assure oil returns to the compressor. Plugging refrigerator in immediately may cause damage to internal parts.
- Use an appliance dolly when moving refrigerator. **ALWAYS** truck refrigerator from its side or back—**NEVER** from its front.
- Protect outside finish of refrigerator during transport by wrapping cabinet in blankets or inserting padding between the refrigerator and dolly.
- Secure refrigerator to dolly firmly with straps or bungee cords. Thread straps through handles when possible. Do not overtighten. Overtightening restraints may dent or damage outside finish.



Installation

Leveling

⚠ CAUTION

To protect personal property and refrigerator from damage, observe the following:

- Protect vinyl or other flooring with cardboard, rugs, or other protective material.
- Do not use power tools when performing leveling procedure.

To enhance the appearance and maintain performance, the refrigerator should be level.

Note

- Complete any required door reversal, panel installation and/or a water supply connection, before leveling.

Materials Needed:

- 3/8" hex head driver
- Carpenter's level

1. Remove toe grille.

- Grasp firmly and pull bottom outward to unclip.

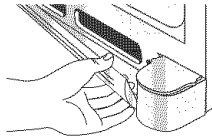

2. Remove bottom bracket cover(s).

- Place the eraser end of a pencil or similar blunt tool in the cover notch.

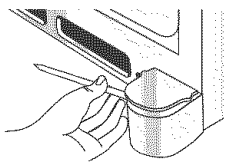

Notch Location →

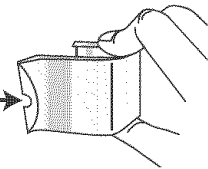

- Use slight pressure to pry the cover loose.
- Continue to maintain downward pressure to the notched side of the cover while swinging it off.

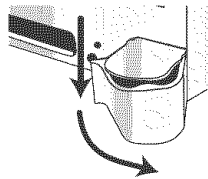

3. Using hex head driver, turn both of the front adjustment screws (A) clockwise to raise and counterclockwise to lower the front of the refrigerator.

4. Turn both rear adjustment screws (B) clockwise to raise and counterclockwise to lower the rear of the refrigerator.

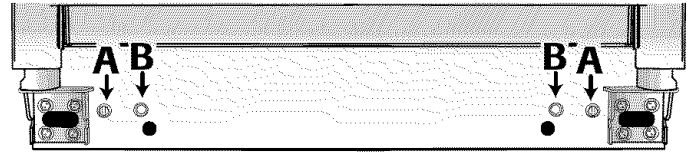

5. Using the carpenter's level, make sure front of refrigerator is 1/4" (6 mm) or 1/2 bubble higher than back of refrigerator and that the refrigerator is level from side to side.

6. If doors are uneven, do the following:

- Determine which door needs to be raised.
- Turn front roller adjustment screw (A) clockwise to raise front corner of door.

- If one refrigerator door has reached the limit of its adjustment range and doors are still not level, raise or lower the opposite door by turning roller adjustment screw counterclockwise.

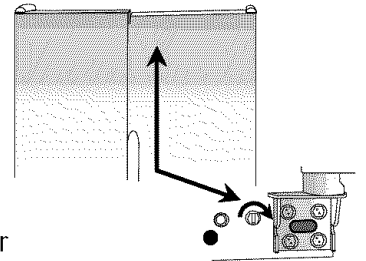

- Check with level to verify 1/4" tilt to the back for proper door closure.
- If refrigerator is aligned and stable, replace toe grille and hinge covers.

7. Replace bracket cover(s).

- Position cover into the outer edge of the hinge.
- Swing the cover toward the cabinet and snap it into place.

8. Replace the toe grille.

Note

- For proper reinstallation, ensure the "top" marking on the interior of the toe grille is oriented correctly.

- Align the toe grille mounting clips with the lower cabinet slots.
- Push the toe grille firmly until it snaps into place.



Installation

Door and Hinge Removal

Some installations require door removal to get refrigerator to final location.

⚠ WARNING

To avoid severe personal injury or death, observe the following:

- Disconnect power to refrigerator before removing doors. Connect power only after replacing doors.
- Green ground wire must be attached to top hinge while performing door removal and replacement.
- Tape decorative panels (select models) securely into place before removing door handles.

⚠ CAUTION

To avoid property damage, observe the following:

- Protect vinyl or other flooring with cardboard, rugs or other protective material, prior to moving refrigerator.

1. Unplug power cord from power source.
2. Remove toe grille and bottom bracket covers (see page 8).
 - Open both doors 180°, or as wide as possible.

Note

- For refrigerators in operation, shut off water before removing water line from the door.

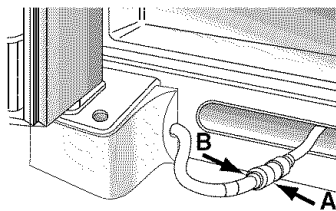

To Disconnect the Water Line:

- Push in white collar (A) and hold.
- Pull the door-side tube from the connector (B).

To Reconnect the Water Line:

- Firmly push tube 5/8" into the connector. Use lines on the tube as a guide for full insertion.

- If tube end is damaged, cut off 5/8" before reconnecting.
- If leaking occurs, disconnect and reconnect the line.

3. Close doors.
4. Remove top hinge covers by removing Phillips screws.
5. Unscrew 5/16" hex head screws from top hinges.
 - Do not remove screw connecting green ground wire.

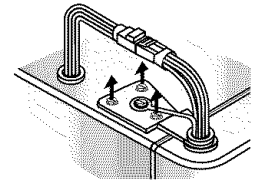
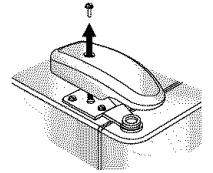

6. Detach main wire connector harness and red wire harness.

- To detach main wire harness, use a flat blade tool or fingernail to press junction point between two connectors to release.
- To detach red wire harness, press tab on underside of connector to release.

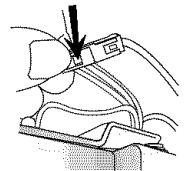
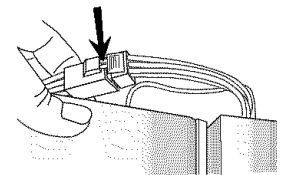

7. Remove top hinges along with doors.

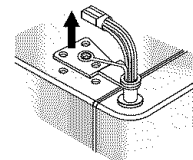
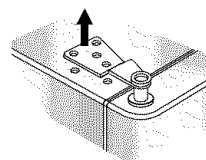

8. Remove bottom hinges with a 3/8" hex head driver.

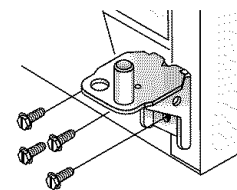

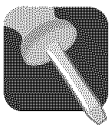

Installation

Replacing the Doors

To replace the doors, follow the steps in *Door and Hinge Removal* in opposite order.

IMPORTANT: If water line tube end is damaged, cut off $\frac{5}{8}$ " before reconnecting.

Handles

To Install:

1. Align fresh food handle with door clip.
2. Make sure the tabs of the handle clip are below the tabs of the door clip.
3. Rotate the handle so that the handle is flat against the door.
4. The tab on the lower part of the handle will align with the hole in the handle cap.
5. Slide handle upward until it clicks. (For freezer handle, repeat steps 1-4, then slide handle downward until it clicks.)

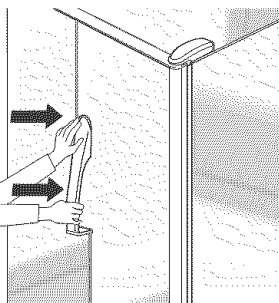
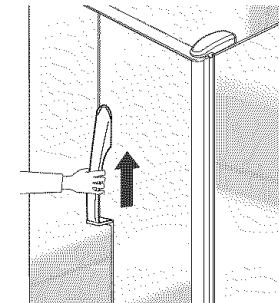
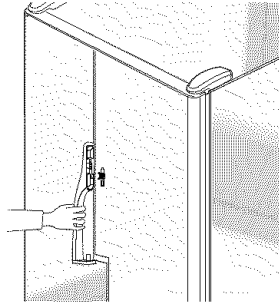

To Remove:

1. Insert door removal card, shipped with refrigerator (or $\frac{1}{32}$ " thick plastic card similar to a credit card) between the handle and door panel (approximately $\frac{3}{4}$ ").

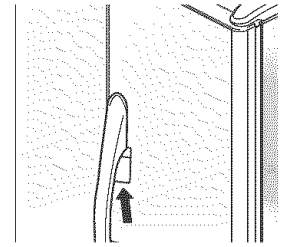

Note

- Wear gloves to protect your hands during removal process.
2. Grasp the handle firmly and pull downward to remove. (For freezer handle, repeat step 1, then grasp the handle firmly and pull upward to remove.)

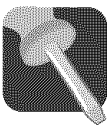

Installation

Connecting the Water Supply

⚠ WARNING

To reduce the risk of injury or death, follow basic precautions, including the following:

- Read all instructions before installing ice maker.
- Do not attempt installation if instructions are not understood or if they are beyond personal skill level.
- Observe all local codes and ordinances.
- Do not service ice maker unless specifically recommended in this Use & Care Guide or published user-repair instructions.
- Disconnect power to refrigerator before installing ice maker.
- Water damage due to an improper water connection may cause mold/mildew growth. Clean up spills or leakage immediately!

⚠ CAUTION

To avoid property damage or possible injury, follow basic precautions, including the following:

- Consult a plumber to connect $\frac{1}{4}$ " O.D. copper tubing to household plumbing to assure compliance with local codes and ordinances.
- Water pressure to water valve must be between 35 and 100 pounds per square inch to function properly. A minimum pressure of 35 pounds per square inch is recommended for refrigerators with water filters.
- Do not use a self-piercing, or $\frac{3}{16}$ " saddle valve. Both reduce water flow, can become clogged over time, and may cause leaks if repair is attempted.
- Tighten nuts by hand to prevent cross threading. Finish tightening nuts with pliers and wrenches. Do not overtighten.
- Wait two to three hours before placing refrigerator into final position to check and correct any water leaks. Recheck for leaks after 24 hours.
- Verify the copper tubing under the sleeve is smooth and free from defects. Do not reuse an old sleeve.

Materials Needed:

- $\frac{1}{4}$ " outer diameter flexible copper tubing
- Shut-off valve (requires a $\frac{1}{4}$ " hole to be drilled into water supply line before valve attachment)
- Adjustable wrench
- $\frac{1}{4}$ " hex nut driver
- Brass nut and sleeve

Note

- Add 8 ft. to tubing length needed to reach water supply for creation of service loop.

1. Create service loop with copper tubing (minimum 2 ft. diameter). Avoid kinks in the copper tubing when bending the service loop.

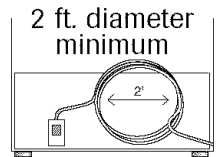

2. Remove plastic cap from water valve inlet port.

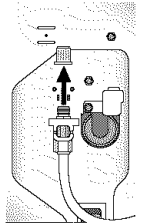

3. Place brass nut (A) and sleeve (B) on copper tube end as illustrated. (Do not use old sleeve.)

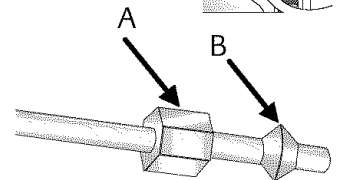

4. Place end of copper tubing into water valve inlet port. Shape tubing slightly - Do not kink - so that tubing feeds straight into inlet port.

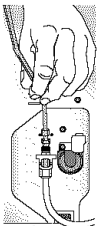

5. Slide brass nut over sleeve and screw nut into inlet port. Tighten nut with wrench.

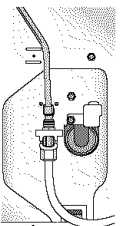

IMPORTANT: Do not overtighten. Cross threading may occur.

6. Pull on tubing to confirm connection is secure. Connect tubing to frame with water tubing clamp (C) and turn on water supply. Check for leaks and correct if necessary. Continue to observe the water supply connection for two to three hours prior to moving the refrigerator to its permanent location.

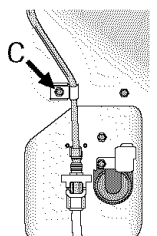

7. Monitor water connection for 24 hours. Correct leaks, if necessary.



Temperature Controls

Temperature Control (select models)



The control is located at the top front of the fresh food compartment.

Initial Control Settings

After plugging the refrigerator in, set the controls.

- Pressing the or pads adjusts the controls to the desired setting.
- Set the freezer control on 4.
- Set the refrigerator control on 4.
- Let the refrigerator run at least 8 to 12 hours before adding food.

Warm Cabinet Surfaces

At times, the front of the refrigerator cabinet may be warm to the touch. This is a normal occurrence that helps prevent moisture from condensing on the cabinet. This condition will be more noticeable when you first start the refrigerator, during hot weather and after excessive or lengthy door openings.

Adjusting the Controls

- 24 hours after adding food, you may decide that one or both compartments should be colder or warmer. If so, adjust the control(s) as indicated in the *Temperature Control Guide* table below.
- Except when starting the refrigerator, do not change either control more than one number at a time.
- Allow 24 hours for temperatures to stabilize.

Temperature Control Guide

Refrigerator too warm	Set the refrigerator control to next higher number by pressing the pad.
Refrigerator too cold	Set the refrigerator control to next lower number by pressing the pad.
Freezer too warm	Set the freezer control to next higher number by pressing the pad.
Freezer too cold	Set the freezer control to next lower number by pressing the pad.
Turn refrigerator OFF	Press the freezer or refrigerator pad until a dash “-” appears in the display.



Temperature Controls

Advanced Temperature Control (select models)

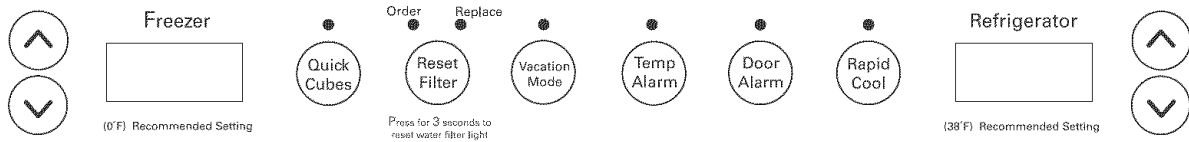

The control is located at the top front of the fresh food compartment.

Initial Temperature Setting

Temperatures are preset at the factory at 38° F (3° C) in the fresh food compartment and 0° F (-18° C) in the freezer compartment.

Adjusting the Control

24 hours after adding food, you may decide that one or both compartments should be colder or warmer. If so, adjust the control as indicated in the Temperature Control Guide below.

- The first touch of the or pads shows the current temperature setting.
- The display will show the new setting for approximately three seconds, and then return to the actual temperature currently within that compartment.
- Do not change either control more than one degree at a time. Allow temperature to stabilize for 24 hours before making a new temperature adjustment.

Temperature Control Guide

Refrigerator too cold	Set the refrigerator control to next higher number by pressing the pad.
Refrigerator too warm	Set the refrigerator control to next lower number by pressing the pad.
Freezer too cold	Set the freezer control to next higher number by pressing the pad.
Freezer too warm	Set the freezer control to next lower number by pressing the pad.
Turn refrigerator OFF	Press the freezer pad until OFF appears in the display. Press either the freezer or refrigerator pad to turn back on.

Quick Cubes

When activated, Quick Cubes reduces the freezer temperature to the optimum setting for 24 hours in order to produce more ice. **Note:** When the Quick Cubes feature is in operation, the and pads for the freezer control will not operate.



Reset Filter

When a water filter has been installed in the refrigerator, the yellow Order light will illuminate when 90 percent of the volume of water for which the filter is rated has passed through the filter OR 11 months have elapsed since the filter has been installed.

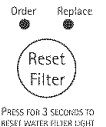

The red Replace light will illuminate when the rated volume of water has passed through the filter OR 12 months have elapsed since the filter was installed. A new filter should be installed immediately when the Replace light is illuminated.

After replacing the filter, press and hold the **Reset Filter** pad for three seconds. The Order and Replace lights will go off.

Vacation Mode

The Vacation Mode feature causes the freezer to defrost less frequently, conserving energy. The Vacation Mode indicator light will illuminate when the feature is activated. To deactivate, press the **Vacation Mode** pad again OR open either door. The indicator light will go out.



Notes

- Door openings will not deactivate Vacation Mode for approximately one hour after activation.
- If vacationing for more than a few days, see the Preparing for Vacation section, page 30.



Temperature Controls

Temp Alarm

The Temp Alarm system will alert you if the freezer or fresh food temperatures exceed normal operating temperatures due to a power outage or other event. When activated, the Temp Alarm light will illuminate.

If the freezer or fresh food temperatures have exceeded these limits, the display will alternately show the current compartment temperatures and the highest compartment temperatures reached when the power was out. An audible alarm will sound repeatedly.



Press the **Temp Alarm** pad once to stop the audible alarm. The Temp Alarm light will continue to flash and the temperatures will alternate until the temperatures have stabilized.

To turn off Temp Alarm, press and hold the **Temp Alarm** pad for three seconds. The indicator light will go off.

Door Alarm

The Door Alarm will alert you when one of the doors has been left open for five continuous minutes. When this happens, an audible alarm will sound every few seconds until the door is closed OR press the **Door Alarm** pad to deactivate the feature.

Rapid Cool

When activated, Rapid Cool causes the fresh food and freezer temperatures to drop to the minimum settings on the control. This cools down the refrigerator and freezer after extended door openings or when loading the refrigerator or freezer with warm food. **Note:** When the Rapid Cool feature is in operation, the  and  pads for the refrigerator and freezer controls will not operate.





To activate, press the **Rapid Cool** pad. Rapid Cool will deactivate automatically after 12 hours, OR press the **Rapid Cool** pad to deactivate the feature.

User Preferences

Access the User Preferences menu to:

- Change the temperature display from °F to °C.
- Enable or disable audible alarms.
- Adjust the light level at which the Dispenser Auto Light will illuminate (when this feature is activated on the ice and water dispenser).
- Activate the Sabbath Mode.

To access the User Preferences menu, press and hold the **Door Alarm** pad for three seconds. When in the User Preferences mode, a short title for the feature will appear in the Freezer temperature display and the feature status will appear in the Fresh Food display.

1. Use the Freezer  and  control to scroll through the features.
2. When the desired feature is displayed, use the Fresh Food  and  control to change the status.
3. When changes are complete, press the **Door Alarm** pad for three seconds OR close the Fresh Food door.

Temperature Display (F_C)

Change the display to show temperatures in degrees Fahrenheit or degrees Celsius.

Alarm (AL)

When the Alarm mode is OFF, all audible alarms will be disabled until the feature is turned on.

Auto Light Level Selection (LL)

This setting adjusts the light level at which the dispenser light will illuminate when the sensor detects that the light levels in the room are low. Setting 1 is the darkest light level setting, setting 9 is the lightest light level setting. **Note:** The Auto Light (select models) must be activated on the ice and water dispenser control to take advantage of this option.

Sabbath Mode (SAB)

When the Sabbath Mode is ON, all control lights and the night light will be disabled until the feature is turned OFF. This feature does not disable the interior lights. Press ANY pad to restore the control lights.

Warm Cabinet Surfaces

At times, the front of the refrigerator cabinet may be warm to the touch. This is a normal occurrence that helps prevent moisture from condensing on the cabinet. This condition will be more noticeable when the refrigerator is first started, during hot weather and after excessive or lengthy door openings.





Fresh Food Features

Shelves

⚠ CAUTION

To avoid personal injury or property damage, observe the following:

- Never attempt to adjust a shelf that is loaded with food.
- Confirm shelf is secure before placing items on shelf.
- Handle tempered glass shelves carefully. Shelves may break suddenly if nicked, scratched, or exposed to sudden temperature change.

Your refrigerator is equipped with spillproof, slide-out shelves which easily store large items such as deli trays. The shelves have a spill retainer edge for easier cleanup. To slide the shelves out, grasp the front of the shelf and pull forward. Push in the shelf to return it to the original position.

To Remove a Shelf:

- Slightly tilt up the front and lift up the rear of the shelf, then pull the shelf straight out.

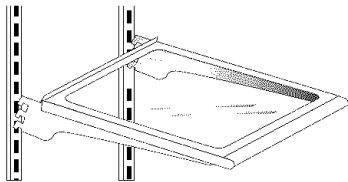

To Lock the Shelf Into Another Position:

- Tilt up the front edge of the shelf.
- Insert the hooks into the desired frame openings and let the shelf settle into place.
- Be sure the shelf is securely locked at the rear.

The Crisper Top serves as the lower fresh food shelf.

To Remove the Crisper Top:

- Remove drawers as indicated (see page 16).
- Place hand under the frame to push up the glass. Lift glass out.

To Install:

- Repeat above instructions in opposite order and manner of removal.

Dairy Center

The Dairy Center provides convenient door storage for spreadable items such as butter and margarine.

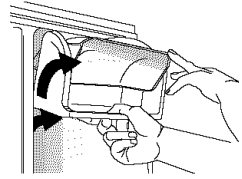

To Remove:

- Slide dairy center up and pull out.

To Install:

- Slide assembly in and down so that the hooks are firmly seated on the door liner.

To Remove Dairy Door:

- Press in sides of dairy door and pull out.

To Install Dairy Door:

- Slide sides of dairy door inside dairy center until hinge points snap into place.

Door Buckets

Door Buckets can be moved to meet individual storage needs.

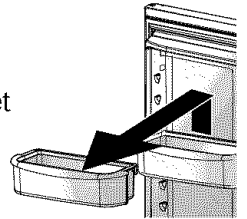

To Remove:

- Lift bucket up and pull straight out.

To Install:

- Place bucket in desired door liner retainer, push down until bucket stops.



Fresh Food Features

Chiller

The Chiller keeps beverages and other items colder than the rest of the fresh food compartment. An air inlet directs air from the freezer into the chiller.

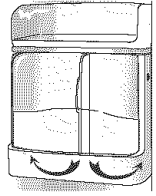

Controls

The chiller control is located on the left side wall of the fresh food compartment. Turn the control clockwise for colder temperature.

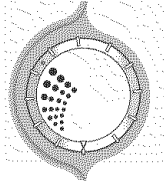

To Remove Chiller:

- Unload the chiller.
- Slide the assembly up and pull straight out.

Note

- The dairy center will need to be removed before removing the chiller.

To Install Chiller:

- Align the air inlet hole with the hole cut-out on the door.
- Slide the assembly in and down so that the hooks are firmly seated on the door liner.

Note

- The Chiller will not operate properly if the air intake hole is not aligned with the control location.

Storage Drawers

Humidity-Controlled Crisper Drawers

The Crisper Drawers provide a higher humidity environment for fresh fruit and vegetable storage.

Controls

The crisper controls regulate the amount of humidity in the crisper drawer. Slide control toward the **LOW** setting for produce with outer skins. Slide control toward the **HIGH** setting for leafy produce.



To Remove:

- Pull drawer out to full extension. (On select models, press tabs towards oneself to release drawer from rails.) Tilt up front of drawer and pull straight out.

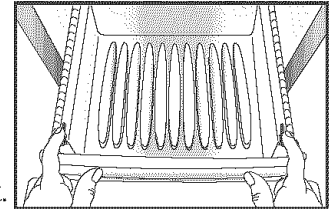

To Install:

- Insert drawer into frame rails and push back into place.

Note

- For best results, keep the crispers tightly closed.

Temperature-Controlled Drawer

This drawer can be used for storage of miscellaneous items.

The drawer features a control that regulates the air temperature in the drawer. Set the control to **Cheese** to provide normal refrigerator temperature. Use the **Meats** setting for meats.

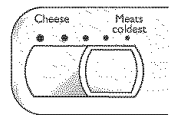

Accessories

Covered Storage Bucket

The Storage Bucket has a lid and removable egg tray. When tray is removed, bucket will accept items such as a standard egg carton, ice, etc.

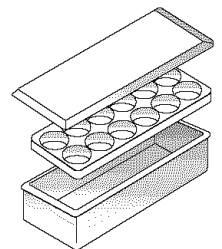



Freezer Features

Shelves and Baskets

Your freezer is equipped with wider baskets and a wider shelf for pizza storage.

Fixed Freezer Shelf

To Remove Clip-mounted Shelves:

- Lift shelf from wall mounting clips and pull left side of shelf out of wall mounting holes.

To Install Clip-mounted Shelves:

- Place left side of shelf in mounting holes and press down into wall mounting clips.

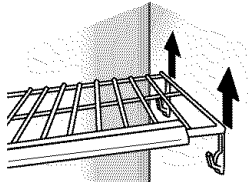

Shelves

Shelves can be removed to meet individual storage needs.

To Remove Shelf:

- Snap right side of shelf up from cabinet railing and slide to right.

To Install Shelf:

- Replace shelf in left side cabinet railing. Snap shelf into right side cabinet railing.

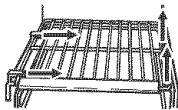

Baskets and Drawers

Baskets and drawers (style may vary) slide out for easy access to items in back.

To Remove:

- Pull out to its full extension. Lift up front of basket and remove.

To Install:

- Slide basket or drawer into cabinet railing. Lift up front of basket or drawer, and slide to the back of refrigerator.

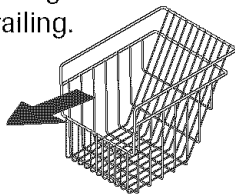

Ice Storage Bin

The Ice Storage Bin is located below the automatic ice maker.

To Remove:

- Raise ice maker arm to deactivate ice maker. Lift front of bin and pull out to its full extension. Lift up front of bin and remove.

To Install:

- Slide bin into railing below ice maker until bin locks into place. Drop ice maker arm to activate ice maker.

IMPORTANT: Ice bin must be locked in place for proper ice dispensing. Turn auger driver behind bin counterclockwise (as shown) to properly align ice bin with auger driver.

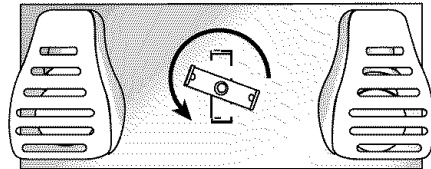

Door Storage

Adjustable Door Buckets

Door Buckets can be moved to meet individual storage needs.

To Remove:

- Lift the door bucket up until it clears the retainers on the door liner, then pull the door bucket straight out.

To Install:

- Slide bucket in above desired door liner retainer and push down until bucket stops.

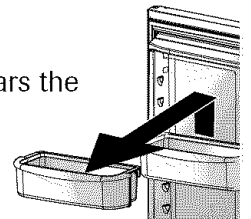

Drop-Down Freezer Door Baskets (select models)

These baskets provide convenient storage space for frozen food items that tend to shift, such as bagged vegetables.

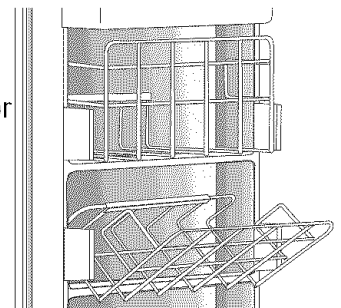



Ice and Water

Automatic Ice Maker

Operating Instructions

- Confirm ice bin is in place and ice maker sensor arm is down.
- After freezer section reaches between 0° to 2° F (-18° to -17° C), ice maker fills with water and begins operating. You will have a complete harvest of ice approximately every three hours.
- Allow approximately 24 hours after installation to receive first harvest of ice.
- Discard ice created within first 12 hours of operation to verify system is flushed of impurities.
- Stop ice production by raising ice maker sensor arm until click is heard.
- Ice maker will remain in the OFF position until sensor arm is pushed down.
- The first one or two batches will probably contain undersized and irregular cubes because of air in the supply line.
- When the ice cubes are ejected it is normal for several cubes to be joined together at the ends. They can easily be broken apart. The ice maker will continue to make ice until the supply of ice cubes raises the sensor arm, shutting the ice maker off.
- Certain sounds may accompany the various cycles of the ice maker. The motor may have a slight hum, the cubes will rattle as they fall into an empty storage pan and the water valve may click or “buzz” occasionally.
- If the ice is not used frequently, the ice cubes will become cloudy, shrink, stick together and taste stale. Empty the ice storage bin periodically and wash it in lukewarm water. Be sure to dry the bin thoroughly before replacing it.

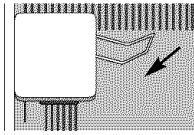

- Beverages and foods should not be placed in the ice storage bin for quick chilling. These items can block the sensor arm, causing the ice maker to malfunction.
- Turn off (sensor arm up) the ice maker when the water supply is to be shut off for several hours.

To Remove the Ice Bin:

- Pull it forward, away from the ice maker. To avoid the ice maker dumping ice while the bin is removed, turn the ice maker off by raising the sensor arm.

To Install the Ice Bin:

- Push the ice bin back towards the ice maker. Turn the ice maker on by lowering the sensor arm.

⚠ WARNING

To avoid personal injury or property damage, observe the following:

- Do not place fingers or hands on the automatic ice making mechanism while the refrigerator is plugged in. This will help protect you from possible injury. It will also prevent interference with moving parts of the ejector mechanism and the heating element that releases the cubes.
- Under certain rare circumstances, ice cubes may be discolored, usually appearing with a green-bluish hue. The cause of this unusual discoloration can be a combination of factors such as certain characteristics of local waters, household plumbing and the accumulation of copper salts in an inactive water supply line which feeds the ice maker. **Continued consumption of such discolored ice cubes may be injurious to health.** If such discoloration is observed, discard the ice cubes and contact your dealer to purchase and install a water line filter.
- Water damage due to improper water connection may cause mold/mildew growth.
- Clean up water and ice spills to avoid personal injury and to prevent mold/mildew growth.



Ice and Water

Dispenser Features

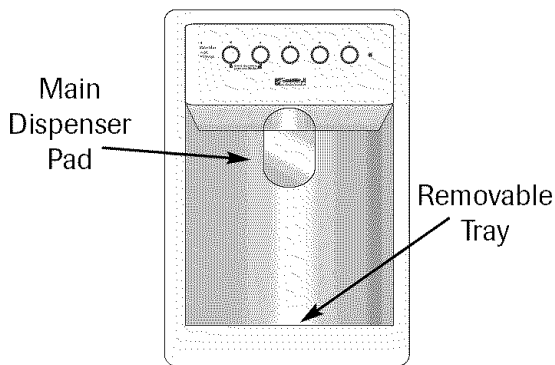

Dispenser Light

A light activates within the dispenser area at full power when dispensing ice or water with the main dispenser pad.

Dispenser Pad

The Dispenser Pad is located on the back wall of the dispensing area. When the **Dispenser** pad is pressed, the selection chosen on the dispenser control panel will dispense.

Removable Tray

The Removable Tray at the bottom of the dispenser area is designed to collect small spills and may be easily removed for cleaning and emptying purposes.

IMPORTANT: Removable tray does not drain. Do not allow tray to overflow. If it does, remove tray and wipe up overflow.

Water Dispenser Operation

⚠ CAUTION

To avoid personal injury or property damage, observe the following:

- Do not put fingers, hands or any foreign object into dispenser opening.
- Do not use sharp objects to break ice.
- Do not dispense ice directly into thin glass, fine china or delicate crystal.

Note

- During initial use of water dispenser, there will be a one- to two-minute delay while water tank fills before water dispenses. Discard first 10-15 glasses of water after initially connecting refrigerator to household water supply and after extended periods of nonuse.



To Use Dispenser Pad:

- Choose water selection from dispenser control panel.
- Press a sturdy, wide-mouthed container against dispenser pad. When dispensing crushed ice, hold container as close to chute as possible to reduce spraying.
- Release pressure on dispenser pad to stop water dispensing. A small amount of water may continue to dispense and collect in dispenser tray. Large spills should be wiped dry.

Dispenser Control

Ice Dispenser Operation

To Dispense Ice and Water:

- Select Water, Crush or Cube ice mode by pushing the    corresponding button on the dispenser control panel. A green light above button indicates mode selection.

- Press container against dispenser pad. When dispensing crushed ice, hold container as close to chute as possible to reduce spraying.

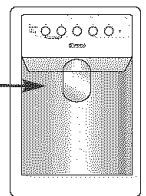

Notes

- Mode may not be changed while ice dispenser is in operation.
- If dispenser is active for more than five minutes, an automatic lock out sensor will shut down power to dispenser area. See *Dispenser Lock*, pg. 20, for unlocking information.



Ice and Water

Dispenser Lock

The Dispenser Lock prevents ice or water from being dispensed.



To Lock Dispenser:

- Press and hold the **Lock** button for three seconds. A green indicator light above the button will illuminate when the dispenser is locked.

To Unlock Dispenser:

- Press and hold the **Lock** button for three seconds. The green indicator light above button will go out.

Water Filter Status Indicator Light (select models)



The Water Filter Status Indicator Light serves as a reminder to replace the water filter. A green light indicates that the filter is in good condition. A red light indicates the filter should be changed. Once light turns red, it will remain red until function is reset.

To Reset Indicator:

- Press and hold both the **Lock** and **Water** buttons simultaneously for four seconds. The green filter status indicator light will flash three times when the function has successfully reset.



Auto Light (Models with Water Filter Status Indicator Light)



The Auto Light function activates the dispenser light at half-power when the Light Sensor detects that the light levels in room are low.

To Activate Auto Light:

- Press **Auto Light** button. A green indicator light above button illuminates when the sensor is active.

To Deactivate Auto Light:

- Press **Auto Light** button. The green indicator light will go out.

Note

- The dispenser light will operate when Auto Light is ON or OFF.

Light

Press the **Light** pad once to select the Auto Light function which activates the dispenser light at half-power when the light sensor detects that the light levels in room are low. The Auto indicator light will illuminate.

To Activate Light:

- Press the **Light** pad again to turn the dispenser light on continuously. The On indicator light will illuminate.

To Deactivate Light:

- Press the **Light** pad again to turn the dispenser light off.

Sabbath Mode (Models with Water Filter Status Indicator Light)

When activated, the Sabbath Mode deactivates the control lights while leaving the control operational.

To Activate Sabbath Mode:

- Press and hold the **Lock** and **Auto Light** buttons simultaneously for three to four seconds. After three to four seconds, the dispenser lights will turn off.



To Deactivate Sabbath Mode:

- Press and hold both the **Lock** and **Auto Light** buttons simultaneously for three to four seconds. After three to four seconds, the dispenser lights will activate.

Notes

- Dispenser light will not activate during dispensing while in this mode.
- If the power fails, the control will remain in Sabbath Mode when power returns.
- Advanced Temperature Control models: see *User Preferences* page 14.



Water Filter

Water Filter Removal and Installation

⚠ WARNING

To avoid serious illness or death, do not use refrigerator where water is unsafe or of unknown quality without adequate disinfection before or after use of filter.

⚠ CAUTION

After installing a new water filter, always dispense water for two minutes before removing the filter for any reason. Air trapped in system may cause water and cartridge to eject. Use caution when removing.

- The bypass cap does not filter water. Be sure to have replacement cartridge available when filter change is required.
- If water filtration system has been allowed to freeze, replace filter cartridge.
- If system has not been used for several months, or water has an unpleasant taste or odor, flush system by dispensing water for two to three minutes. If unpleasant taste or odor persists, change filter cartridge.

Initial Installation

The water filter is located in the upper right-hand corner of the fresh food compartment.

1. Remove blue bypass cap and retain for later use.
2. Remove sealing label from end of filter and insert into filter head.
3. Rotate gently clockwise until filter stops. Snap filter cover closed.

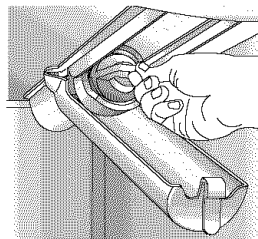

4. Reduce water spurts by flushing air from system. Run water continuously for two minutes through dispenser until water runs steady. During initial use, allow about a one- to two-minute delay in water dispersal to allow internal water tank to fill.

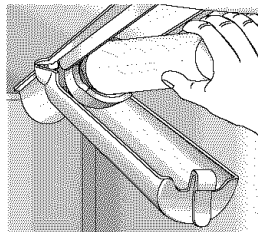

- Additional flushing may be required in some households where water is of poor quality.

Replacing Water Filter

IMPORTANT: Air trapped in system may cause water and cartridge to eject. Use caution when removing.

1. Turn filter counterclockwise until it releases from filter head.
2. Drain water from filter into sink, and dispose in normal household trash.
3. Wipe up excess water in filter cover and continue with *Initial Installation*, steps 2 through 4.

The filter should be changed at least every 12 months.

IMPORTANT: Condition of water and amount used determines life span of water filter cartridge. If water use is high, or if water is of poor quality, replacement may need to take place more often.

To purchase a replacement water filter cartridge, contact your dealer or call 1-800-4-MY-HOME® (1-800-469-4663) in USA and Canada.

The dispenser feature may be used without a water filter cartridge. If you choose this option, replace filter with blue bypass cap.



Water Filter

System Specification and Performance Data Sheet Refrigerator Water Filter Cartridge Model 469006-750

Specifications

Service Flow Rate (Maximum).....0.78 GPM (2.9 L/min)
 Rated Service Life 469006-750 (Maximum).....750 gallons/2838 liters
 Maximum Operating Temperature100° F/38° C
 Minimum Pressure Requirement.....35 psi/241 kPA
 Minimum Operating Temperature33° F/1° C
 Maximum Operating Pressure.....120 psi /827 kPA



1000 Apollo Road
 Eagan, Minnesota 55121-2240
 651.450.4913
 EPA EST #35917-MN-1

Performance Data

100834/B

Standard No. 42: Aesthetic Effects								
Parameter	USEPA MCL	Influent Challenge Concentration	Influent Average	Effluent		% Reduction		Min. Required Reduction
				Average	Maximum	Average	Minimum	
Chlorine	-	2.0 mg/L ± 10%	1.88 mg/L	<0.05136364 mg/L	0.06 mg/L	>97.26%	96.84%	50%
T & O	-	-	-	-	-	-	-	-
Particulate**	-	at least 10,000 particles/ml	5,700,000 #/ml	30,583 #/ml	69,000 #/ml	99.52%	98.94%	85%

Standard No. 53: Health Effects								
Parameter	USEPA MCL	Influent Challenge Concentration	Influent Average	Effluent		% Reduction		Min. Required Reduction
				Average	Maximum	Average	Minimum	
Turbidity	1 NTU**	11 ± 1 NTU***	10.7 NTU	0.31 NTU	.049 NTU	97.09%	95.20%	0.5 NTU
Cysts	99.5% Reduction	Minimum 50,000/L	166,500 #/L	<1 #/L	<1 #/L	>99.99%	>99.99%	>99.95%
Asbestos	99% Reduction	10 ⁷ 10 ⁸ fibers/L; fibers >10 micrometers in length	155 MF/L	<1 MF/L	<1 MF/L	>99.99%	>99.99%	99%
Lead at pH 6.5	0.015 mg/L	0.15 mg/L + 10%	0.153 mg/L	<.001 mg/L	<.001 mg/L	>99.35%	>99.29%	0.10 mg/L
Lead at pH 8.5	0.015 mg/L	0.15 mg/L + 10%	0.150 mg/L	<.001 mg/L	<.001 mg/L	>99.33%	>99.29%	0.10 mg/L
Mercury at pH 6.5	0.002 mg/L	.006 mg/L ± 10%	0.006 mg/L	0.0003 mg/L	0.0005 mg/L	95.70%	90.91%	0.002 mg/L
Mercury at pH 8.5	0.002 mg/L	.006 mg/L ± 10%	0.006 mg/L	0.0008 mg/L	0.0015 mg/L	86.22%	75.93%	0.002 mg/L
Atrazine	0.003 mg/L	0.009 mg/L + 10%	0.009 mg/L	<0.002 mg/L	0.002 mg/L	76.99%	75.31%	0.003 mg/L
Benzene	0.005 mg/L	0.015 mg/L ± 10%	0.014 mg/L	0.0006 mg/L	0.0011 mg/L	95.71%	92.14%	0.005 mg/L
Carbofuran	0.04 mg/L	0.08 mg/L ± 10%	0.081 mg/L	<0.001 mg/L	<0.001 mg/L	98.74%	98.46%	0.04 mg/L
p-Dichlorobenzene	0.075 mg/L	.225 mg/L ± 10%	0.208 mg/L	<0.0005 mg/L	<0.0005 mg/L	99.76%	99.74%	0.075 mg/L
Lindane	0.0002 mg/L	0.002 mg/L + 10%	0.002 mg/L	0.000 mg/L	<0.0001 mg/L	98.72%	96.50%	0.0002 mg/L
Toxaphene	0.003 mg/L	0.015 ± 10%	0.015 mg/L	<0.001 mg/L	<0.001 mg/L	92.97%	91.67%	0.003 mg/L

* Tested using a flow rate of 0.78 gpm; pressure of 60 psig; pH of 7.5 + 0.5; temp. of 68° + 5° F (20° + 3° C)

** Measurement in Particles/ml. Particles used were 0.5 - 1 microns

*** NTU - Nephelometric Turbidity Units



Tested and certified by NSF International against ANSI/NSF Standards 42 & 53 in models 469006-750 for the reduction of:

Standard No. 42: Aesthetic Effects
 Taste and Odor Reduction
 Chlorine Taste & Odor
 Mechanical Filtration Unit
 Particulate Reduction Class 1

Standard No. 53: Health Effects
 Chemical Reduction Unit
 Lead, Atrazine, Lindane, Benzene,
 Carbofuran, p-Dichlorobenzene, Mercury
 & Toxaphene Reduction
 Mechanical Filtration Unit
 Cyst, Turbidity and Asbestos Reduction

General Use Conditions

Read this Performance Data Sheet and compare the capabilities of this unit with your actual water treatment needs.

DO NOT use this product where water is microbiologically unsafe or of unknown quality without adequate disinfection before or after the system. System certified for cyst reduction may be used on disinfected water that may contain filterable cysts.

USE ONLY WITH COLD WATER SUPPLY. CHECK FOR COMPLIANCE WITH THE STATE AND LOCAL LAWS AND REGULATIONS.

The retractable water filtration system uses a 469006-750 replacement cartridge. Timely replacement of filter cartridge is essential for performance satisfaction from this filtration system. Please refer to the applicable section of your Use & Care Guide for general operation, maintenance requirements and troubleshooting. Suggested retail price of replacement water filter is \$39.99.

This system has been tested according to ANSI/NSF 42 and 53 for reduction of the substance listed above. The concentration of the indicated substances in water entering the system was reduced to a concentration less than or equal to the permissible limit for water leaving the system, as specified in ANSI/NSF 42 and 53.



Water Filter

State of California
Department of Health Services

Water Treatment Device Certificate Number

03 - 1583

Date Issued: September 16, 2003

Date Revised: April 22, 2004

Trademark/Model Designation

UKF8001AXX750
469006-750
67003523-750

Replacement Elements

UKF8001AXX
46 9006
67003523

Manufacturer: PentaPure Inc.

The water treatment device(s) listed on this certificate have met the testing requirements pursuant to Section 116830 of the Health and Safety Code for the following health related contaminants:

Microbiological Contaminants and Turbidity

Cysts
Turbidity

Inorganic/Radiological Contaminants

Asbestos
Lead
Mercury

Organic Contaminants

Atrazine
Lindane
Benzene
Carbofuran
p-dichlorobenzene
Toxaphene

Rated Service Capacity: 750 gal.

Rated Service Flow: 0.78 gpm

Conditions of Certification:

Do not use where water is microbiologically unsafe or with water of unknown quality, except that systems certified for cyst reduction may be used on disinfected waters that may contain filterable cysts.



Food Storage Tips

Fresh Food Storage

- The fresh food compartment of a refrigerator should be kept between 34°-40° F (1°-4° C) with an optimum temperature of 38° F (3° C). To check the temperature, place an appliance thermometer in a glass of water and place in the center of the refrigerator. Check after 24 hours. If the temperature is above 40° F (4° C) adjust the controls as explained on pages 12, 13 and 14.
- Avoid overcrowding the refrigerator shelves. This reduces the circulation of air around the food and results in uneven cooling.

Fruits and Vegetables

- Storage in the crisper drawers traps humidity to help preserve the fruit and vegetable quality for longer time periods (see page 16).
- Sort fruits and vegetables before storage and use bruised or soft items first. Discard those showing signs of decay.
- Always wrap odorous foods such as onions and cabbage so the odor does not transfer to other foods.
- While vegetables need a certain amount of humidity to remain fresh, too much humidity can shorten storage times (especially leafy vegetables). Drain vegetables well before storing.
- Wait to wash fresh produce until right before use.

Meat and Cheese

- Raw meat and poultry should be wrapped securely so leakage and contamination of other foods or surfaces does not occur.
- Occasionally mold will develop on the surface of hard cheeses (Swiss, Cheddar, Parmesan). Cut off at least an inch around and below the moldy area. Keep your knife or instrument out of the mold itself. Do not try to save individual cheese slices, soft cheese, cottage cheese, cream, sour cream or yogurt when mold appears.

Dairy Food

- Most dairy foods such as milk, yogurt, sour cream and cottage cheese have freshness dates on their cartons for appropriate length of storage. Store these foods in the original carton and refrigerate immediately after purchasing and after each use.

Frozen Food Storage

- The freezer compartment of a refrigerator should be kept at approximately 0° F (-18° C). To check the temperature, place an appliance thermometer between the frozen packages and check after 24 hours. If the temperature is above 0° F (-18° C), adjust the control as described on pages 12, 13 and 14.
- A freezer operates more efficiently when it is at least two-thirds full.

Packaging Foods for Freezing

- To minimize dehydration and quality deterioration use aluminum foil, freezer wrap, freezer bags or airtight containers. Force as much air out of the packages as possible and be sure they are tightly sealed. Trapped air can cause the food to dry out, change color and develop an off-flavor (freezer burn).
- Overwrap fresh meats and poultry with suitable freezer wrap prior to freezing.
- Do not refreeze meat that has completely thawed.

Loading the Freezer

- Avoid adding too much warm food to the freezer at one time. This overloads the freezer, slows the rate of freezing and can raise the temperature of frozen foods.
- Leave space between the packages so cold air can circulate freely, allowing food to freeze as quickly as possible.
- Avoid storing hard-to-freeze foods such as ice cream and orange juice on the freezer door shelves. These foods are best stored in the freezer interior where the temperature varies less with door openings.

Refer to the *Food Storage Chart* on pages 25 and 26 for approximate storage times.



Food Storage Tips

Food Storage Chart

Storage times are approximate and may vary depending on type of packaging, storage temperature, and the quality of the food when purchased.

FOODS	REFRIGERATOR	FREEZER	STORAGE TIPS
DAIRY PRODUCTS			
Butter	1 month	6 to 9 months	Wrap tightly or cover.
Milk and cream	1 week	Not recommended	Check carton date. Close tightly. Don't return unused portions to original container. Don't freeze cream unless whipped.
Cream cheese, cheese spread and cheese food	1 to 2 weeks	Not recommended	Wrap tightly.
Cottage cheese	3 to 5 days	Not recommended	Store in original carton. Check carton date.
Sour cream	10 days	Not recommended	Store in original carton. Check carton date.
Hard cheese (Swiss, Cheddar and Parmesan)	1 to 2 months	4 to 6 months May become crumbly	Wrap tightly. Cut off any mold.
EGGS			
Eggs in the shell	3 weeks	Not recommended	Refrigerate small ends down.
Leftover yolks or whites	2 to 4 days	9 to 12 months	For each cup of yolks to be frozen, add 1 tsp. sugar for use in sweet, or 1 tsp. salt for non-sweet dishes.
FRUITS			
Apples	1 month	8 months (cooked)	May also store unripe or hard apples at 60° to 70° F (16° to 21° C).
Bananas	2 to 4 days	6 months (whole/peeled)	Ripen at room temperature before refrigerating. Bananas darken when refrigerated.
Pears, plums, avocados	3 to 4 days	Not recommended	Ripen at room temperature before refrigerating. Avocados darken when refrigerated.
Berries, cherries, apricots	2 to 3 days	6 months	Ripen at room temperature before refrigerating.
Grapes	3 to 5 days	1 month (whole)	Ripen at room temperature before refrigerating.
Citrus fruits	1 to 2 weeks	Not recommended	May also store at 60° to 70° F (16° to 21° C). If refrigerated, store uncovered.
Pineapples, cut	2 to 3 days	6 to 12 months	Will not ripen after purchase. Use quickly.

continued...



Food Storage Tips

FOODS	REFRIGERATOR	FREEZER	STORAGE TIPS
VEGETABLES			
Asparagus	1 to 2 days	8 to 10 months	Do not wash before refrigerating. Store in crisper.
Brussels sprouts, broccoli, cauliflower, green peas, lima beans, onions, peppers	3 to 5 days	8 to 10 months	Wrap odorous foods. Leave peas in pods.
Cabbage, celery	1 to 2 weeks	Not recommended	Wrap odorous foods and refrigerate in crisper.
Carrots, parsnips, beets and turnips	7 to 10 days	8 to 10 months	Remove tops. Wrap odorous foods and refrigerate in the crisper.
Lettuce	7 to 10 days	Not recommended	
POULTRY and FISH			
Chicken and Turkey, whole	1 to 2 days	12 months	Keep in original packaging for refrigeration. Place in the meat and cheese drawer. When freezing longer than two weeks, overwrap with freezer wrap.
Chicken and Turkey, pieces	1 to 2 days	9 months	
Fish	1 to 2 days	2 to 6 months	
MEATS			
Bacon	7 days	1 month	
Beef or lamb, ground	1 to 2 days	3 to 4 months	Fresh meats can be kept in original packaging for refrigeration.
Beef or lamb, roast and steak	3 to 5 days	6 to 9 months	Place in the meat and cheese drawer. When freezing longer than two weeks, overwrap with freezer wrap.
Ham, fully cooked, whole	7 days	1 to 2 months	
half	5 days	1 to 2 months	
slices	3 days	1 to 2 months	
Luncheon meat	3 to 5 days	1 to 2 months	Unopened, vacuum-packed luncheon meat may be kept up to two weeks in the meat and cheese drawer.
Pork, roast	3 to 5 days	4 to 6 months	
Pork, chops	3 to 5 days	4 months	
Sausage, ground	1 to 2 days	1 to 2 months	
Sausage, smoked	7 days	1 to 2 months	
Veal	3 to 5 days	4 to 6 months	
Frankfurters	7 days	1 month	Processed meats should be tightly wrapped and stored in the meat and cheese drawer.

Sources: United States Department of Agriculture; Food Marketing Institute; Cooperative Extension Service, Iowa State University



Care and Cleaning

⚠ WARNING

To avoid electrical shock which can cause severe personal injury or death, disconnect power to refrigerator before cleaning. After cleaning, reconnect power.

⚠ CAUTION

To avoid personal injury or property damage, observe the following:

- Read and follow manufacturer's directions for all cleaning products.
- Do not place buckets, shelves or accessories in dishwasher. Cracking or warping of accessories may result.

Refrigerator Cleaning Chart

PART	DO NOT USE	DO
Textured Doors and Exterior Cabinet Interior	Abrasive or harsh cleaners Ammonia Chlorine bleach Concentrated detergents or solvents Metal or plastic-textured scouring pads	Use 4 tablespoons of baking soda dissolved in 1 quart (1 liter) warm soapy water. Rinse surfaces with clean warm water and dry immediately to avoid water spots.
Stainless Steel Doors and Exterior IMPORTANT: <i>Damage to stainless steel finish due to improper use of cleaning products or non-recommended products is not covered under this product's warranty.</i>	Abrasive or harsh cleaners Ammonia Chlorine bleach Concentrated detergents or solvents Metal or plastic-textured scouring pads Vinegar-based products Citrus-based cleaners	Use warm, soapy water and a soft, clean cloth or sponge. Rinse surfaces with clean warm water and dry immediately to avoid water spots. To polish and help prevent fingerprints, follow with stainless steel cleaner*.
Door Gaskets	Abrasive or harsh cleaners Metal or plastic-textured scouring pads	Use warm, soapy water and a soft, clean cloth or sponge.
Condenser Coil <i>Remove base grille to access.</i>		Use a vacuum cleaner hose nozzle.
Condenser Fan Outlet Grille <i>See back of refrigerator.</i>		Use a vacuum cleaner hose nozzle with brush attachment.
Accessories <i>Shelves, buckets, drawers, etc.</i>	A dishwasher	Follow removal and installation instructions from appropriate feature section. Allow accessories to adjust to room temperature. Dilute mild detergent and use a soft clean cloth or sponge for cleaning. Use a plastic bristle brush to get into crevices. Rinse surfaces with clean warm water. Dry glass and clear items immediately to avoid spots.

* To order, call 1-800-4-MY-HOME® (1-800-469-4663).



Care and Cleaning

Removing Odors From Refrigerator

⚠ WARNING

To avoid electrical shock which can cause severe personal injury or death, disconnect power to refrigerator before cleaning. After cleaning, reconnect power.

1. Remove all food and turn the refrigerator OFF.
2. Disconnect power to the refrigerator.
3. Clean the walls, floor, ceiling of cabinet interior, drawers, shelves and gaskets according to the instructions (see page 27).
4. Dilute mild detergent and brush solution into crevices using a plastic bristle brush. Let stand for five minutes. Rinse surfaces with warm water. Dry surfaces with a soft, clean cloth.
5. Wash and dry all bottles, containers and jars. Discard spoiled or expired items.
6. Wrap or store odor-causing foods in tightly sealed containers to prevent reoccurring odors.
7. Reconnect power to refrigerator and return food to refrigerator.
8. Allow the refrigerator to cool.
9. After 24 hours, check if odor has been eliminated.

If odor is still present:

1. Remove drawers and place on top shelf of refrigerator.
2. Pack refrigerator and freezer sections – including doors – with crumpled sheets of black and white newspaper.
3. Place charcoal briquettes randomly on crumpled newspaper in both freezer and refrigerator compartments.
4. Close doors and let stand 24 to 48 hours.

Energy Saving Tips

- Avoid overcrowding refrigerator shelves. This reduces air circulation around food and causes refrigerator to run longer.
- Avoid adding too much warm food to refrigerator at one time. This overloads compartments and slows rate of cooling.
- Do not use aluminum foil, wax paper, or paper toweling as shelf liners. This decreases air flow and causes refrigerator to run less efficiently.
- A freezer that is two-thirds full runs most efficiently.
- Locate refrigerator in coolest part of room. Avoid areas of direct sunlight, or near heating ducts, registers or other heat producing appliances. If this is not possible, isolate exterior by using a section of cabinet or an added layer of insulation.
- Clean door gaskets every three months according to cleaning instructions. This will assure that door seals properly and refrigerator runs efficiently.
- Take time to organize items in refrigerator to reduce time that door is open.
- Be sure your doors are closing securely by leveling refrigerator as instructed in your installation instructions.
- Clean condenser coils as indicated in the cleaning instructions every three months. This will increase energy efficiency and cooling performance.



Care and Cleaning

Replacing Light Bulbs

⚠ WARNING

To avoid electrical shock which can cause severe personal injury or death, disconnect power to refrigerator before replacing light bulb. After replacing light bulb, reconnect power.

⚠ CAUTION

To avoid personal injury or property damage, observe the following:

- Allow light bulb to cool.
- Wear gloves when replacing light bulb.

Upper Fresh Food Section

The upper fresh food light bulbs are located behind the front panel. Reach behind the panel to remove the bulbs.

Lower Fresh Food Section

1. Push up on bottom tabs on light cover. Rotate cover up and release tabs.
2. Remove light bulb.
3. Replace bulb with appliance bulb **no greater than 40 watts.**
4. Insert top tabs of light cover into liner slots and snap bottom tabs into liner slots.

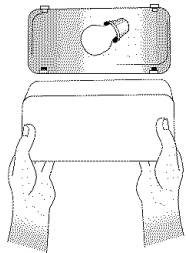
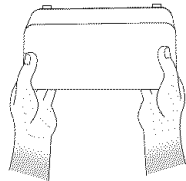

Upper Freezer Section

1. Remove ice bin by lifting front of bin and pulling out.
2. Remove light shield by pressing the upper right side of the shield and rotating downward.
3. Remove light bulb. Replace with appliance bulb **no greater than 40 watts.**
4. Rotate the shield upward, press in slightly and snap into place.
5. Replace ice bin by sliding in until bin locks into place.

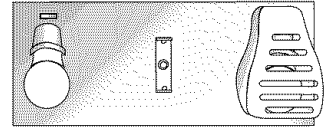

Lower Freezer Section

1. Pinch both sides of light cover to remove.
2. Remove light bulb. Replace with appliance bulb **no greater than 40 watts.**
3. Pinch both sides of the light cover to snap into place.

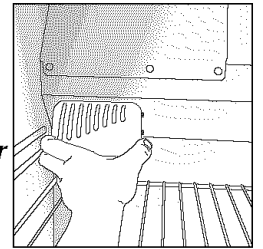

Ice and Water Dispenser

1. Locate light bulb inside top edge of dispenser frame. Unscrew to remove.
2. Replace light bulb with a **7-watt, 120 volt bulb.**

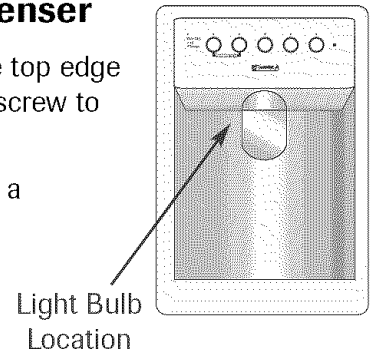

Light Bulb Location



Care and Cleaning

Preparing for Vacation

⚠ CAUTION

If your refrigerator has a dispenser and there is any possibility that the temperature can drop below freezing where the refrigerator is located, the water supply system (including the water tank and the water valve) must be drained by a qualified servicer.

For short vacations or absences (three months or less):

1. Remove all perishables.
2. If no one will be checking in on the refrigerator during your absence, remove all frozen items also.
3. If your refrigerator has an automatic ice maker:
 - Shut off the water supply to the ice maker at least one day ahead of time.
 - After the last load of ice drops, raise the wire shut off arm to the OFF position.
 - Empty the ice bin.
4. If the room temperature will drop below 55° F (13° C), follow the instructions for longer absences.

For long vacations, absences (more than three months) OR if the room temperature will drop below 55° F (13° C):

1. Remove food.
2. If your refrigerator has an automatic ice maker:
 - Shut off the water supply to the ice maker at least one day ahead of time.
 - After the last load of ice drops, raise the wire shut off arm to the OFF position.
 - Empty the ice bin.
3. If your refrigerator has a dispenser system with water filter, remove the water filter cartridge and install the filter bypass. Dispose of the used cartridge.
4. Turn the freezer control to OFF.
5. Unplug the refrigerator.
6. Thoroughly clean the interior of both compartments with a baking soda solution and a clean soft cloth (four tablespoons of baking soda in one quart of warm water.).
7. Dry thoroughly.
8. Leave the doors open to prevent the formation of mold and mildew.

Upon Your Return:

After a Short Vacation or Absence:

For models with automatic ice makers or dispensers:

- Reconnect and turn on water supply (see page 11).
- Monitor water connection for 24 hours and correct leaks if necessary.
- Run 10-15 glasses of water from the dispenser to flush out the system.
- Restart the ice maker.
- Discard at least the first three ice harvests.

After a Long Vacation or Absence:

- If your refrigerator has an automatic ice maker, reconnect the water supply and turn on supply valve (see page 11).
- Plug the refrigerator back in and reset controls (see pages 12, 13 and 14).
- Monitor water connection for 24 hours and correct leaks, if necessary.

Run water through the dispenser for at least three minutes with the filter bypass in place, then install water filter (see page 21).

- After installing the water filter, run water through the dispenser continuously for at least two minutes, or until water runs steady. Initially you may notice a one to two minute delay in water dispersal as the internal tanks fills.
- Restart the ice maker.
- Discard ice produced within the first 12 hours (at least the first three harvests).

Preparing to Move

- Follow the instructions for long vacations/absences, through step 7.
- Secure all loose items such as shelves and drawers by taping them securely in place to prevent damage.
- Tape the doors shut.
- Use an appliance dolly when moving the refrigerator. Always truck the refrigerator from its side or back-never from its front.
- Be sure the refrigerator stays in an upright position during moving.

Operating Sounds

Improvements in refrigeration design may produce sounds in your new refrigerator that are different or were not present in an older model. These improvements were made to create a refrigerator that is better at preserving food, is more energy efficient and is quieter overall. Please note that the surfaces adjacent to a refrigerator, such as hard walls, floors and cabinetry may make these sounds seem even louder. The following are some of the normal sounds that may be noticed in a new refrigerator.

SOUND	POSSIBLE CAUSE	SOLUTION
Clicking	• Freezer control (A) clicks when starting or stopping compressor.	• Normal operation
	• Defrost timer or electric damper control (B) sounds like an electric clock and snaps in and out of defrost cycle.	• Normal operation
Air rushing or whirring	• Condenser fan (D) makes this noise while operating.	• Normal operation
	• Freezer fan (C) makes this noise while operating.	• Normal operation
	• Freezer fan (C) slows to a stop as the freezer door is opened.	• Normal operation
Gurgling or boiling sound	• Evaporator (E) and heat exchanger (F) refrigerant make this noise when flowing.	• Normal operation
Thumping	• Ice cubes from ice maker drop into ice bucket (G) .	• Normal operation
	• Dispenser ice chute (H) closing.	• Normal operation
Vibrating noise	• Compressor (I) makes a pulsating sound while running.	• Normal operation
	• Refrigerator is not level.	• See <i>Leveling</i> (see page 8).
Buzzing	• Ice maker water valve (J) hookup buzzes when ice maker fills with water.	• Normal operation
Humming	• Ice maker (K) is in the 'on' position without water connection.	• Normal operation
	• Ice auger (L) hums as auger agitates ice during dispensing.	• Stop sound by raising ice maker arm to OFF position. See <i>Automatic Ice Maker</i> , page 18 for details.
	• Compressor (I) can make a high pitched hum while operating.	• Normal operation
	• Solenoid valve (M) operating ice chute door.	• Normal operation

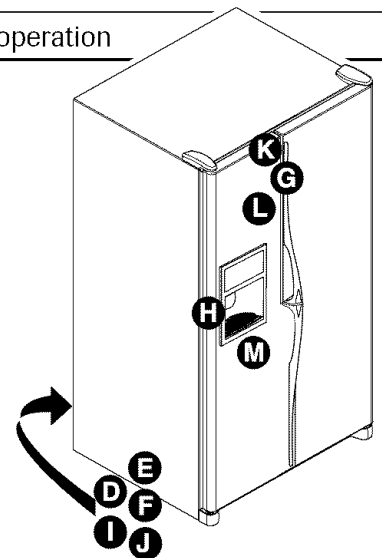
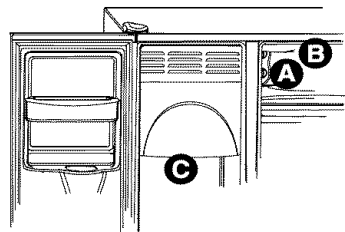



Troubleshooting

PROBLEM	POSSIBLE CAUSES	WHAT TO DO	
Freezer control and lights are on, but compressor is not operating	Refrigerator is in defrost mode.	Normal operation. Wait 40 minutes to see if refrigerator restarts.	
Temperature-controlled drawers are too warm	Control settings are too low.	See page 16 to adjust controls.	
	Freezer controls are set too low.	See pages 12, 13 and 14 to adjust controls.	
	Drawer is improperly positioned.	See page 16 to verify drawer positioning.	
Refrigerator does not operate	Refrigerator is not plugged in.	Plug in refrigerator.	
	Temperature controls are set to “-”.	See pages 12, 13 and 14 to adjust controls.	
	Fuse is blown, or circuit breaker needs to be reset.	Replace any blown fuses. Check circuit breaker and reset, if necessary.	
	Power outage has occurred.	Call local power company listing to report outage.	
Refrigerator still won't operate	Refrigerator is malfunctioning.	Unplug refrigerator and transfer food to another refrigerator. If another refrigerator is not available, place dry ice in freezer section to preserve food. Warranty does not cover food loss. Contact Sears for assistance. (see page 36)	
Food temperature is too cold	Condenser coils are dirty.	Clean according to the chart on page 27.	
	Refrigerator or freezer controls are set too high.	See pages 12, 13 and 14 to adjust controls.	
	Food is too close to upper left side of refrigerator.	Relocate food.	
Food temperature is too warm	Door is not closing properly.	Refrigerator is not level. See page 8 for details on how to level your refrigerator. Check gaskets for proper seal. Clean, if necessary, according to the chart on page 27. Check for internal obstructions that are keeping door from closing properly (i.e. improperly closed drawers, ice buckets, oversized or improperly stored containers, etc.)	
	Controls need to be adjusted.	See pages 12, 13 and 14 to adjust controls.	
	Condenser coils are dirty.	Clean according to the chart on page 27.	
	Rear air grille is blocked.	Check the positioning of food items in refrigerator to make sure grille is not blocked. Rear air grilles are located under crisper drawers.	
	Door has been opened frequently, or has been opened for long periods of time.	Reduce time door is open. Organize food items efficiently to assure door is open for as short a time as possible.	
	Food has recently been added.	Allow time for recently added food to reach refrigerator or freezer temperature.	
	Refrigerator has an odor	Odor producing foods should be covered or wrapped.	Clean according to instructions on page 27.
		The interior needs cleaning.	



Troubleshooting

PROBLEM	POSSIBLE CAUSES	WHAT TO DO
Water droplets form on outside of refrigerator	Door gaskets are not sealing properly.	Clean according to the chart on page 27.
	Humidity levels are high.	Normal during times of high humidity.
	Controls require adjustment.	See pages 12, 13 and 14 to adjust controls.
Water droplets form on inside of refrigerator	Humidity levels are high or door has been been opened frequently.	Reduce time door is open. Organize food items efficiently to assure door is open for as short a time as possible.
	Door gaskets are not sealing properly.	Clean according to the chart on page 27.
Refrigerator or ice maker makes unfamiliar sounds or seems too loud	Normal operation.	See page 31.
Temperature-controlled drawer and/or crisper drawer do not close freely	Contents of drawer, or positioning of items in the surrounding compartment could be obstructing drawer.	Reposition food items and containers to avoid interference with the drawers.
	Drawer is not properly installed.	See page 16 for proper installation.
	Refrigerator is not level.	See page 8 for details on how to level your refrigerator.
	Drawer channels are dirty.	Clean drawer channels with warm, soapy water. Rinse and dry thoroughly. Apply a thin layer of petroleum jelly to drawer channels.
Refrigerator runs too frequently	Doors have been opened frequently or for long periods of time.	Reduce time door is open. Organize food items efficiently to assure door is open for as short a time as possible. Allow interior environment to adjust for period the door has been opened.
	Humidity or temperature in surrounding area is high.	Normal operation.
	Food has recently been added.	Allow time for recently added food to reach refrigerator or freezer temperature.
	Refrigerator is exposed to heat by environment or by appliances nearby.	Evaluate your refrigerator's environment. Refrigerator may need to be moved to run more efficiently.
	Condenser coils are dirty.	Clean according to the chart on page 27.
	Controls need to be adjusted.	See pages 12, 13 and 14 to adjust controls.
	Door is not closing properly.	Refrigerator is not level, see page 8 <i>Leveling</i> . Check for internal obstructions that are keeping door from closing properly (i.e. improperly closed drawers, ice buckets, oversized or improperly stored containers, etc.)
	Door gaskets are not sealing properly.	Cleaning according to the chart on page 27.

continued...



Troubleshooting

Ice and Water

PROBLEM	POSSIBLE CAUSES	WHAT TO DO
No indicator lights are lit on dispenser control	Freezer door is not closed.	Verify that freezer door is closed. Power is removed from the control when freezer door is opened.
	Refrigerator is not plugged in.	Plug in refrigerator.
	Fuse is blown, or circuit breaker needs to be reset.	Replace any blown fuses. Check circuit breakers for any tripped circuits.
	Power outage has occurred.	Call local power company listing to report outage.
	Refrigerator is in Sabbath Mode.	See <i>Sabbath Mode</i> page 20.
Ice or water are not dispensed when pads are pressed	Freezer door is not closed.	Verify that freezer door is closed. Power is removed from the control when freezer door is opened.
	Controls are in lock mode.	See <i>Dispenser Lock</i> page 20.
	Water tank is filling.	At initial use, there is an approximate one- to two-minute delay in dispensing while the internal water tank is filling.
	Ice maker has just been installed or a large amount of ice has been used.	Wait 24 hours for ice production to begin or for ice maker to restock after emptied.
	Water filter is clogged or needs to be changed.	Change water filter (see page 21).
Ice maker is not producing enough ice or ice is malformed	Ice maker has just been installed or a large amount of ice has been used.	Wait 24 hours for ice production to begin or for ice maker to restock after emptied.
	Water pressure is too low.	Low water pressure can cause valve to leak. Water pressure must be between 35 to 100 pounds per square inch to function properly. A minimum pressure of 35 pounds per square inch is recommended for refrigerators with water filters.
	Water filter is clogged or needs to be changed.	Change water filter (see page 21).
Ice maker is not producing ice	Ice maker arm is up.	Confirm ice maker arm is down. See <i>Automatic Ice Maker</i> page 18.
	Household water supply is not reaching water valve.	See <i>Connecting the Water Supply</i> page 11.
	Copper tubing has kinks.	Turn off water supply and remove kinks. If kinks cannot be removed, replace tubing.
	Water pressure is too low.	Water pressure must be between 35 to 100 pounds per square inch to function properly. A minimum pressure of 35 pounds per square inch is recommended for refrigerators with water filters.
	Check freezer temperature.	See <i>Temperature Controls</i> pages 12, 13 and 14 to adjust controls. Freezer must be between 0° to 2° F (-18° to -17° C) to produce ice.
	Ice bin is not installed properly.	See <i>Ice Storage Bin</i> page 17.
	Improper water valve was installed.	See <i>Connecting the Water Supply</i> page 11. Self-piercing and 3/16" saddle valves cause low water pressure and may clog the line over time. Sears is not responsible for property damage due to installation or water connection not performed by Sears.
Water filter indicator light is red	Water filter needs to be replaced.	If filter is not available, replace with bypass filter. See <i>Water Filter</i> page 21.
	Filter indicator sensor needs to be reset.	See <i>Filter Status Indicator Light</i> page 20.



Troubleshooting

PROBLEM	POSSIBLE CAUSES	WHAT TO DO
Ice forms in inlet tube to ice maker	Water pressure is low.	Water pressure must be between 35 to 100 pounds per square inch to function properly. A minimum pressure of 35 pounds per square inch is recommended for refrigerators with water filters.
	Saddle valve not open completely.	Open saddle valve completely.
	Freezer temperature is too high.	See <i>Temperature Controls</i> pages 12, 13 and 14. Freezer temperature should be between 0° to 2° F (-18° to -17° C).
Refrigerator is leaking water	Plastic tubing was used to complete water connection.	The manufacturer recommends using copper tubing for installation. Plastic is less durable and can cause leakage. Sears is not responsible for property damage due to installation or water connection not performed by Sears.
	Improper water valve was installed.	See <i>Connecting the Water Supply</i> page 11. Self-piercing and 3/16" saddle valves cause low water pressure and may clog the line over time. Sears is not responsible for property damage due to installation or water connection not performed by Sears.
Water flow is slower than normal	Water pressure is low.	Water pressure must be between 35 to 100 pounds per square inch to function properly. A minimum pressure of 35 pounds per square inch is recommended for refrigerators with water filters.
	Saddle valve not open completely.	Open saddle valve completely.
	Improper water valve was installed.	See <i>Connecting the Water Supply</i> page 11. Self-piercing and 3/16" saddle valves cause low water pressure and may clog the line over time. Sears is not responsible for property damage due to installation or water connection not performed by Sears.
	Copper tubing has kinks.	Turn off water supply and remove kinks. If kinks cannot be removed, replace tubing.
	Water filter is clogged or needs to be changed.	Change water filter (see page 21).
Dispenser water is not cold	Refrigerator has been recently installed.	Allow approximately 12 hours for water in holding tank to chill.
	Water supply in holding tank has been depleted.	
	Water has settled into water lines outside holding tank and has warmed to room temperature.	Discard first glass of water and refill.
Water appears cloudy	Air or air bubbles in water.	This is normal when first using the dispenser and will disappear with use.
Particles in water and/or ice cubes.	Carbon dust from water filter cartridge.	Initial water ejected through cartridge may contain harmless carbon dust flushed from cartridge. Particles are safe for consumption. Will disappear after the first few uses.
	Concentrations of minerals in water will form particles when water becomes frozen and melts.	Particles are not harmful and naturally occur in water supplies.

Get it fixed, at your home or ours!

Your Home

For repair – **in your home** – of **all** major brand appliances, lawn and garden equipment, or heating and cooling systems, **no matter who made it, no matter who sold it!**

For the replacement parts, accessories and owner's manuals that you need to do-it-yourself.

For Sears professional installation of home appliances and items like garage door openers and water heaters.

1-800-4-MY-HOME® (1-800-469-4663)

Call anytime, day or night (U.S.A. and Canada)

www.sears.com www.sears.ca

Our Home

For repair of carry-in items like vacuums, lawn equipment, and electronics, call or go on-line for the location of your nearest

Sears Parts & Repair Center.

1-800-488-1222

Call anytime, day or night (U.S.A. only)

www.sears.com

To purchase a protection agreement (U.S.A.) or maintenance agreement (Canada) on a product serviced by Sears:

1-800-827-6655 (U.S.A.)

1-800-361-6665 (Canada)

Para pedir servicio de reparación a domicilio, y para ordenar piezas:

1-888-SU-HOGARSM

(1-888-784-6427)

Au Canada pour service en français:

1-800-LE-FOYER^{MC}

(1-800-533-6937)

www.sears.ca



®Registered Trademark / TM Trademark / SM Service Mark of Sears, Roebuck and Co.

®Marca Registrada / TM Marca de Fábrica / SM Marca de Servicio de Sears, Roebuck and Co.

^{MC} Marque de commerce / ^{MD} Marque déposée de Sears, Roebuck and Co.

© Sears, Roebuck and Co.