

---

# Self-Propelled WindTunnel™ Bagless with Powered Hand Tool by HOOVER

---

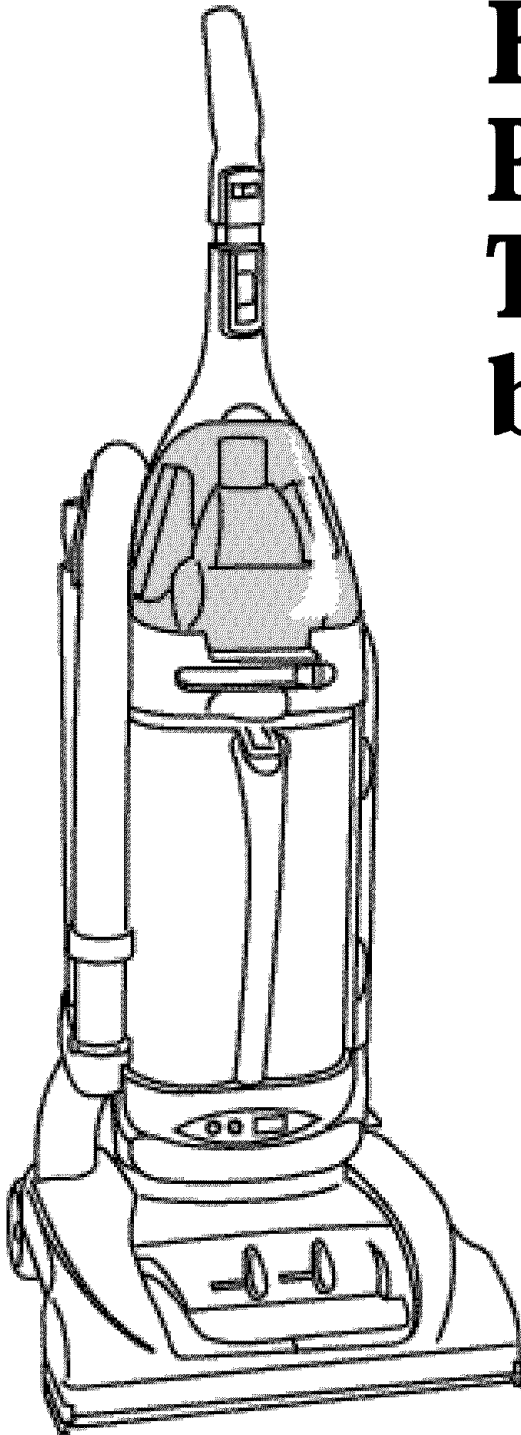

**This product was designed for  
easy Assembly (See page 3)**

[www.hoover.com](http://www.hoover.com)

---

# Owner's Manual

ENGLISH → pp. 1-15  
ESPAÑOL → pág. 17-26  
FRANÇAIS → p. 27-36

Review this manual before  
operating cleaner

## Fill in and retain

The model and serial number are located on the back of the handle as shown.

For your personal records, please enter the **COMPLETE** model and serial number in the spaces provided and retain this information.

Your cleaner is model \_\_\_\_\_

and has serial number \_\_\_\_\_

It is suggested that you attach your sales receipt to this owner's manual. Verification of date of purchase may be required for warranty service of your HOOVER product.

Be sure to fill out and return the product registration card included with your cleaner.

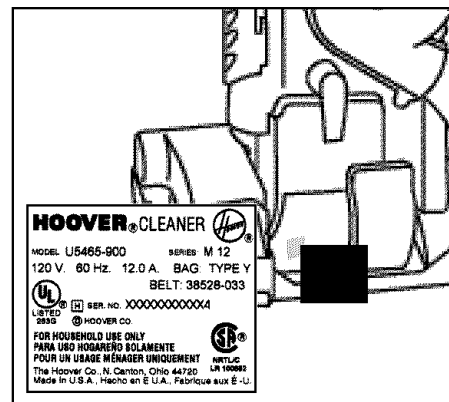

## Index

Assembling Cleaner	3
Carton Contents	3
How To Use	
Cleaner Descriptions	4
Cleaning Tools	6-7
Embedded Dirt FINDER™ Feature	5
Upright Cleaner	4-6
Self-Propel Feature	4
Important Safeguards	2
Maintenance	
Authorized Service	13
Cleaning Filters	8-9
Emptying Cup	7-9
Lubrication	13
Replacing Belts	10-11
Replacing Power Hand Tool Belt	12
Replacing Brush Roll	10-11
Replacing Power Hand Tool Agitator	
Brush Roll	11-12
Replacing Edge Groomers	13
Replacing Headlight	9
Thermal Protector	13
Trouble Shooting	14
Clearing Blockages	14-15
Warranty	14

## Important Safeguards!

When using an electrical appliance, always follow basic precautions, including the following:

**READ ALL INSTRUCTIONS BEFORE USING THIS APPLIANCE**

### Warning:

To reduce the risk of fire, electric shock, or injury:

- Do not use outdoors or on wet surfaces.
- Close supervision is necessary when any appliance is used by or near children. Do not allow vacuum cleaner to be used as a toy or to run unattended at any time.
- Keep hair, loose clothing, fingers, feet and all parts of body away from openings, rotating agitator and other moving parts. Do not operate cleaner in bare feet or when wearing open toe shoes or sandals.
- Do not pick up anything that is burning or smoking, such as cigarettes, matches, or hot ashes.
- Do not use to pick up flammable or combustible materials such as gasoline or fine wood sandings or use in areas where they may be present.
- Avoid picking up hard, sharp objects with the cleaner. They may damage the cleaner.
- Always turn off this appliance before connecting or disconnecting hose.
- Do not use without dirt cup or filters in place. Empty cup and clean filter frequently when picking up very fine materials such as powder.
- Use extra care when cleaning on stairs.
- Do not put any object into openings. Do not use with any opening blocked; keep free of dust, lint, hair, or anything that may reduce air flow.
- Do not pull or carry by cord, use cord as a handle, close door on cord or pull cord around sharp edges or corners. Do not run appliance over cord. Keep cord away from heated surfaces.
- Always disconnect cord from electrical outlet before servicing the cleaner.
- Unplug cleaner when not in use. Turn off all controls before unplugging.
- Do not unplug by pulling on cord. To unplug, grasp the plug, not the cord. Never handle plug or appliance with wet hands.
- The use of an extension cord is not recommended.
- Do not use with damaged cord or plug. If appliance is not working as it should, has been dropped, damaged, left outdoors, or dropped into water, take it to a Hoover Factory Service Center or Authorized Hoover Warranty Service Dealer (Depot).
- Use vacuum cleaner only for its intended use as described in the instructions. Use only attachments recommended by The Hoover Company; others may cause hazards.



© 2001 The Hoover Company  
www.hoover.com

## Save these instructions!

# 1. Assembling cleaner

This cleaner was inspected and packaged carefully before being shipped from the factory. If you should happen to need assistance during assembly or operation, call

**1-800-944-9200** for an automated referral of authorized service outlet locations (U.S. only)

OR

1-330-499-9499 to speak with a representative in our Consumer Response Center

OR

Visit us online at [www.hoover.com](http://www.hoover.com) to find the service outlet nearest you (click on the "Service" button).

## Carton contents

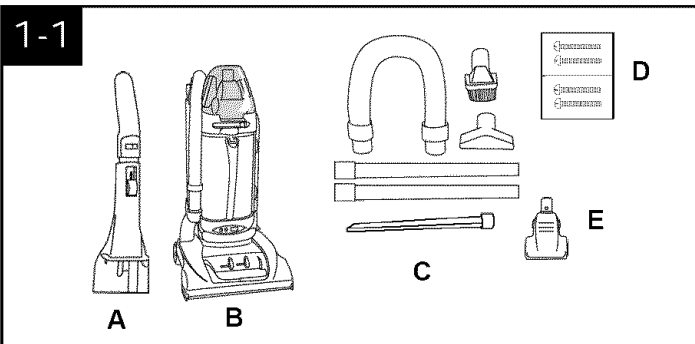

Remove all parts from carton and identify each item shown. Make sure all parts are located before disposing of packing.

A. Handle section

B. Cleaner body

C. Hose\*, cleaning tools and wands (packed on cleaner)

D. Handle screw packet (in bag with owner's manual)

E. Powered hand tool (packed on cleaner)

\*some models include an extra hose

**Note:** The white switch lock above the ON/OFF switch aids in the assembly of your cleaner. Assembly can be continued if the switch lock is missing. However, **do not remove** the switch lock **until assembly is completed**.

## Easy 3-step assembly

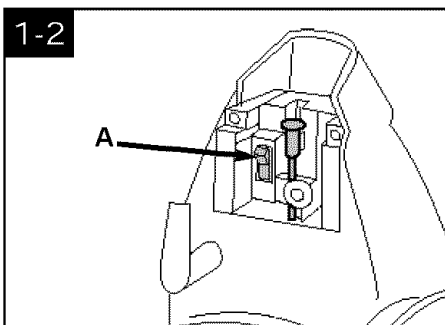

Looking at the back of the cleaner, make sure switch (A) is in the OFF position.

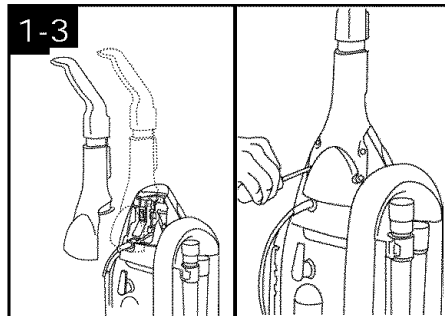

It may be necessary to move the hose in order to attach the handle.

Slide handle into back of cleaner.

Push 4 screws into holes on back of handle.

Using a Phillips screw driver, tighten screws securely.

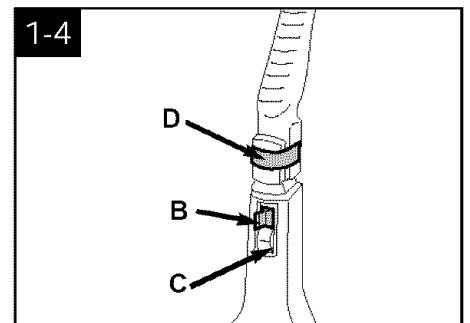

Remove switch lock (B) above ON/OFF switch (C) on front of handle by pulling it straight out. Dispose of lock.

**If switch lock has come off during assembly, make sure switch is in OFF position (down) before plugging cord into electrical outlet.**

Remove label (D) from self-propel button.

You are now ready to use  
America's Best Cleaning Upright!

Continued → 3

## 2. How to use

### Cleaner description

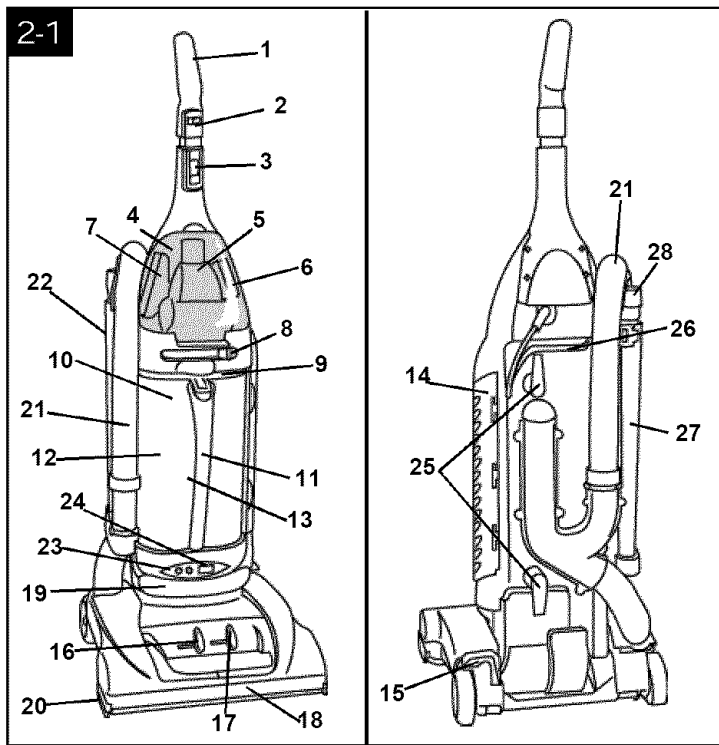

The assembled cleaner will look like the drawing.

1. Handle
2. Self-propel button
3. ON-OFF switch
4. Tool cover
5. Powered hand tool
6. Dusting brush
7. Furniture nozzle
8. Dirt cup latch
9. Dirt cup lid
10. Dirt cup
11. Dirt cup handle
12. HEPA cartridge filter (inside dirt cup)
13. Pre-filter (inside dirt cup)
14. Final filter
15. Three-position handle release pedal: step on pedal to lower handle to operating or low positions.
16. Nozzle control knob: slide knob to correct setting for height of carpet being cleaned.
17. Brush roll control
18. Furniture guard
19. Headlight
20. Edge groomers
21. Hose
22. Hose rack
23. 'Dirt FINDER' display
24. Embedded 'Dirt FINDER' sensitivity switch
25. Cord hooks: wrap cord around hooks for storage. The top hook can be rotated right or left for easy cord release.
26. Carrying handle
27. Extension wands
28. Crevice wand: stores in rear wand.

Operate cleaner only at voltage specified on data plate on bottom of cleaner.

This cleaner is intended for household use.

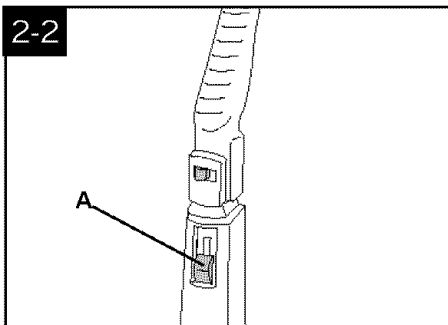

#### ON-OFF Switch

Plug cord into electrical outlet.  
To turn cleaner ON, push switch (A) up.  
To turn cleaner OFF, push switch down.

#### Polarized plug

Note: To reduce the risk of electric shock, this appliance has a polarized plug (one blade is wider than the other). This plug will fit in a polarized outlet only one way. If the plug does not fit fully in the outlet, reverse the plug. If it still does not fit, contact a qualified electrician to install the proper outlet. Do not change the plug in any way.

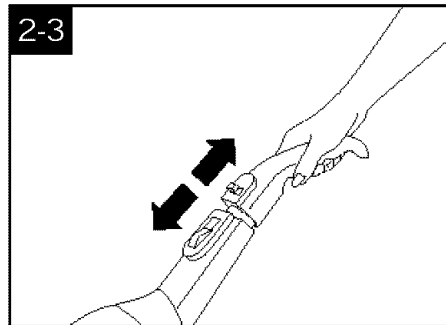

#### Self-propel feature

This feature allows you to control how quickly the cleaner moves.

**Note: The self-propel feature operates only when the cleaner switch and the self propel button are both ON.**

**To move forward**, push handle forward and guide cleaner away from you.

**To move backward**, gently pull handle back and guide the cleaner toward you.

Guide cleaner carefully at first until you have adjusted to the ease of operation.

**For increased control in tight places** (e.g., around and under furniture, non-carpeted floors), slide the self-propel button to OFF to deactivate the feature.

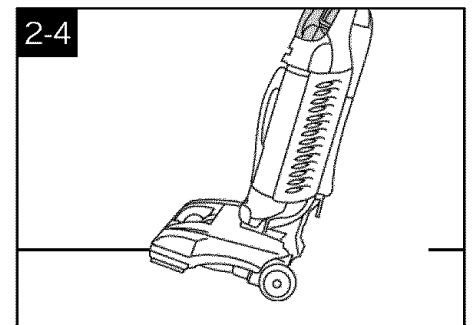

#### Transporting cleaner

To move your cleaner from room to room, put handle in upright position, tilt cleaner back on rear wheels and push forward.

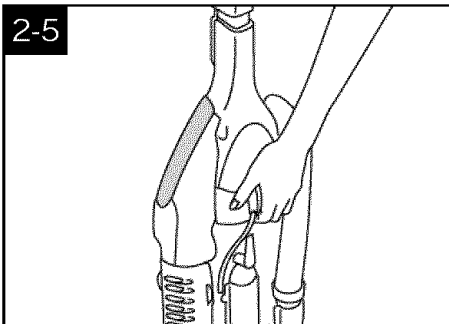

## Carrying cleaner

The cleaner can be lifted by using the carrying handle on the back of the cleaner.

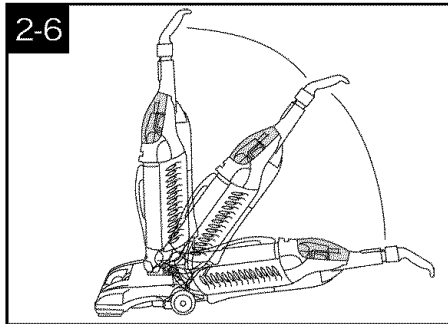

## Handle positions

The handle of your cleaner has three positions; **upright** for storage and when using cleaning tools; **operating position** for general operation on carpet and floors; **low** for reaching under low furniture.

Step on handle release lever to lower handle.

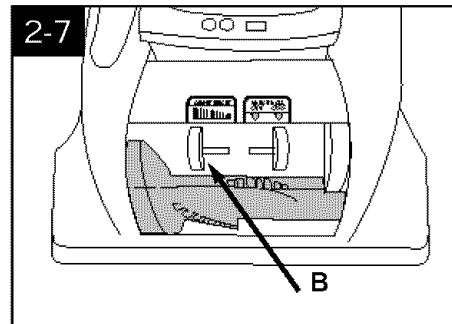

## Carpet height adjustment

When it is necessary to raise and lower the front of the cleaner for various carpet pile heights, slide the carpet height control (B) to the desired setting.

**For maximum cleaning performance,** the following carpet height settings are recommended:

- Low setting: for all types of carpet
- Higher settings: for very deep pile carpet where easier pushing effort is desired, while maintaining good cleaning performance.

Note: If the cleaner is difficult to push, slide control to the next higher setting.

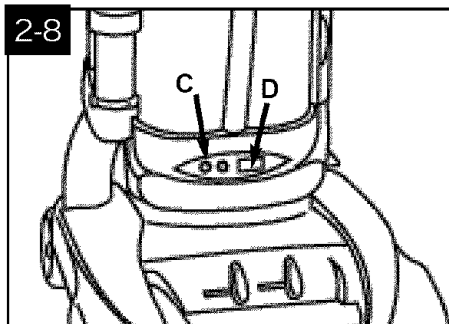

## Embedded Dirt FINDER™ feature

With red and green lights (C), the 'Dirt FINDER' system alerts the user to areas of carpet that may need more cleaning attention. It is able to sense when larger amounts of dirt particles, especially embedded dirt, are removed.

To let you know that the 'Dirt FINDER' feature is ready the red light will come on when the cleaner is first turned on. After a few seconds, the red light will go off and the **green light** will come on.

**Cleaning may then begin.**

The **green light will remain on** throughout cleaning **except** when the detector senses that a **larger amount of dirt** is being picked up; then the **red light** will come on.

When the **red light** is on, you should **take additional cleaning strokes** in the area until it changes to green.

•The red light may seldom come on during cleaning. This means that your cleaner is picking up primarily fine surface dust and lint which the system may not detect, or that the carpet is generally clean. **To increase** the feature's **sensitivity to dirt**, set the switch (D) to the "Hi" position.

•At other times, the red light may stay on for a considerable amount of time. This means that the carpet contains a high level of dirt which is being removed by the cleaner. **To decrease** the feature's **sensitivity to dirt**, set the switch (D) to the "Reg." (Regular) position.

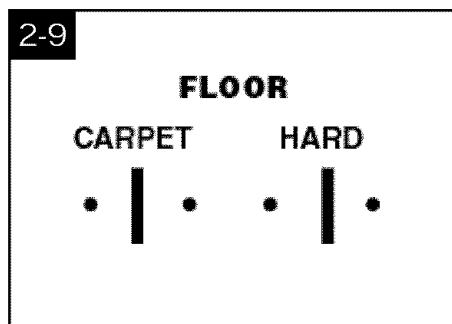

## Brush roll control

**Note: When handle is in upright position, brush roll is automatically OFF.**

Move the brush roll control only when the handle is in the upright position.

Slide control to "Carpet" to turn brush roll ON for cleaning carpet or rugs.

Slide control to "Hard" to turn brush roll OFF when cleaning bare floors.

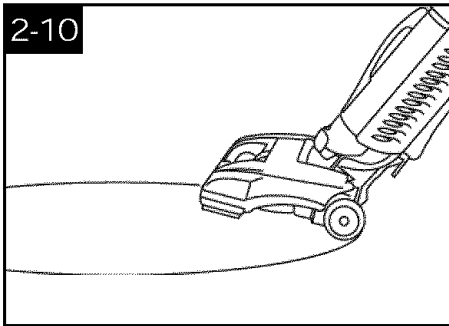

## Cleaning lightweight flexible rugs

Stand on one end of rug and move cleaner toward other end or edge. Before reaching edge, push down on handle. This will lift up the nozzle (front of cleaner) as shown and will prevent rug from clinging to cleaner.

Continue to lift up nozzle so that when you have reached the edge, it is completely off the rug. Move cleaner back to start again, lower nozzle, and use only forward strokes.

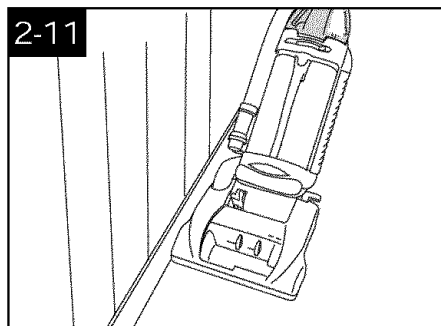

## Edge cleaning

Special edge groomers are provided on both sides of the nozzle to remove dirt in carpet near baseboards and furniture.

Guide either side of nozzle parallel to the edge of carpet or furniture.

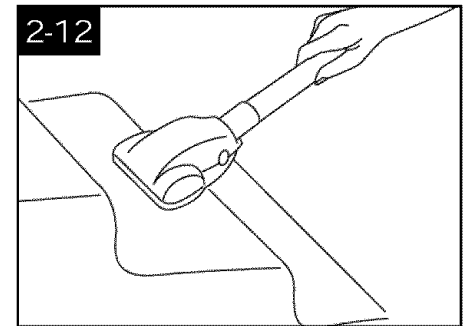

## Stair Cleaning

Use the hose and powered hand tool or furniture nozzle for stair cleaning. Clean from bottom to top.

**CAUTION: To avoid personal injury or unnecessary wear to carpet, and to prevent the cleaner from falling, always place it at bottom of stairs.**

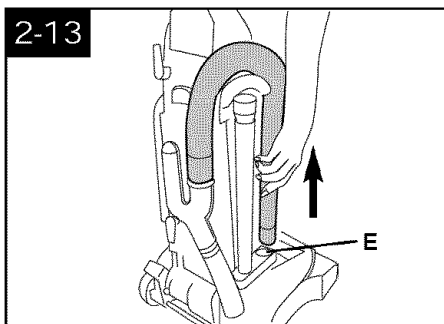

## Cleaning tools

When using cleaning tools, cleaner handle must be in the upright position to activate the automatic "brush roll OFF" and for convenience in moving the cleaner from one area to another.

Turn cleaner OFF before disconnecting and connecting hose to hose tube (E).

To use hose, lift hose end as shown.

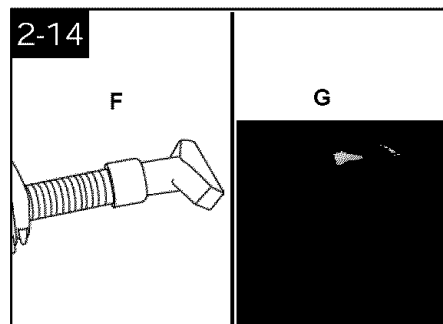

## Attach wand and tools

Attach any tool or wand to the hose (F) by pushing it firmly into hose.

Attach second wand or tool to wand (G) by pushing it firmly onto the wand.

Twist wand or tool slightly to tighten or loosen the connection.

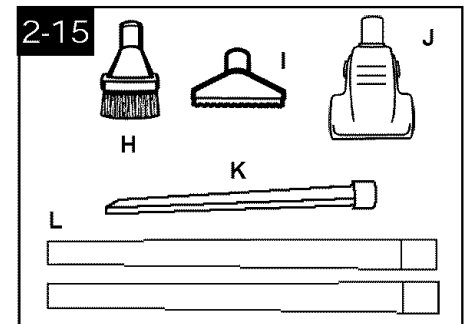

## Select proper tool

**H. Dusting brush** may be used for carved furniture, table tops, books, lamps, lighting fixtures, venetian blinds, baseboards, shutters, and registers.

**I. Furniture nozzle** may be used for upholstered furniture, draperies, mattresses, clothing, automobile interiors, and carpeted stairs.

**J. Powered hand tool** may be used for upholstered furniture, carpeted stairs and hard-to-reach places.

**K. Crevice wand** can be used in tight spaces, corners and along edges in such places as dresser drawers, upholstered furniture, stairs, and baseboards. It can also be used for extra reach with the dusting brush and/or extension wand.

**L. Wands** are used to give extra length to your hose. Use them with any of the above tools.

2-16

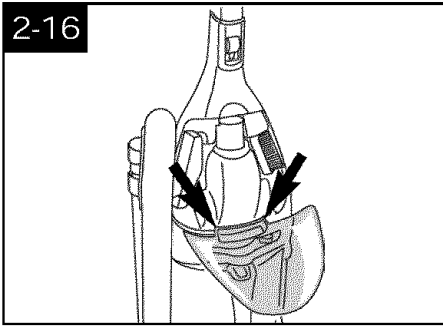

### How to attach tool cover

The tool cover is designed with a "break-away" feature which allows it to snap free if it is pushed open too far.

To reattach, align hinges of cover with slots on sides of tool storage area.

Push cover down to secure in place.

### How to clean tools

To clean the hose and the powered hand tool, wipe off dirt with a cloth dampened in a mild detergent. Rinse with a damp cloth. Do not submerge powered hand tool in water.

Cleaning tools may be washed in warm water with a detergent. Rinse and air dry before using.

2-17

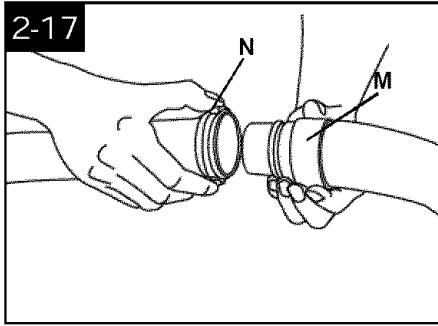

### Extra hose\*

The extra hose\* may be used when additional length is required, such as for cleaning stairs.

The extra hose fits onto the cleaner's hose.

Remove hose end from cleaner (Fig. 2-13).

Insert short end (M) of extra hose into cleaner hose.

To remove extra hose, squeeze raised area on cleaner's hose connector (N).

\*Available at additional cost if not included with your cleaner.

## 3. Maintenance

Familiarize yourself with these home maintenance tasks as proper use and care of your cleaner will ensure continued cleaning effectiveness.

3-1

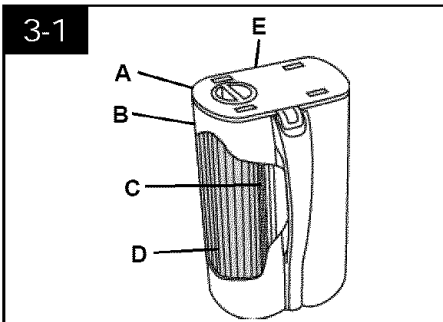

### Dirt cup

The dirt cup assembly consists of the following parts:

- Lid (A)
- Dirt Cup (B)
- Pre-filter (C)
- HEPA Cartridge Filter (D)
- Dirt Inlet Opening (E)

While the cleaner is in operation, the pre-filter screen will stop larger debris from entering the HEPA cartridge filter chamber. This larger debris will be seen collecting in the left side of the dirt cup. The HEPA cartridge filter will collect fine particles that have passed through the pre-filter screen.

### When to empty

It is recommended that the dirt cup be emptied before the dirt reaches the dirt inlet opening on back of dirt cup (Fig. 3-1) or after every use if preferred.

**CAUTION: Very fine materials, such as face powder, cornstarch or fire-place soot, may seal the filter and cause loss of suction. When using the cleaner for this type of dust, empty the cup and clean the filters often.**

3-2

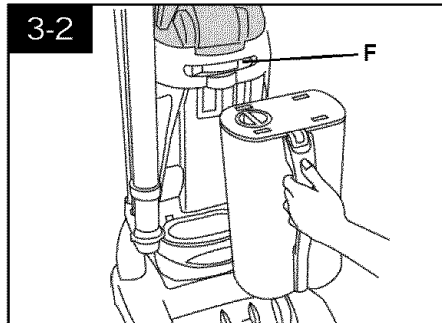

### How to empty

**Disconnect cleaner from electrical outlet. Do not use cleaner without dirt cup or filters in place.**

Slide latch (F) to the left to unlock.

Lift cup slightly and pull **straight** out to remove from cleaner.

3-3

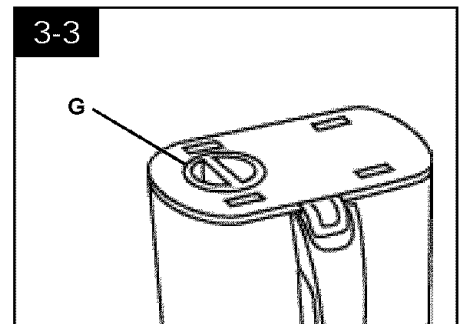

To remove loose dirt from the HEPA filter, turn knob (G) on top of dirt cup lid at least one complete turn.

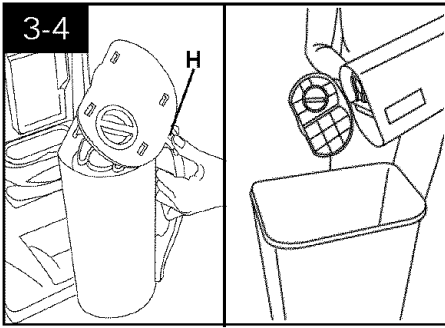

Press down on area indicated (H) to open dirt cup lid. Empty cup.

**Note:** It is not necessary to remove the HEPA cartridge filter to empty the dirt cup.

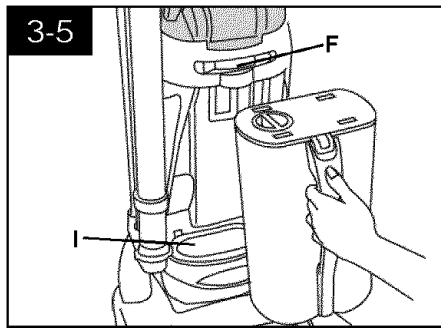

Close dirt cup lid.

**Note:** If dirt cup lid does not close completely, turn knob on lid until lid closes.

Slide cup **straight** into cleaner cavity. Bottom of cup will rest behind grooves at bottom of cleaner cavity (I).

Press latch (F) to the right to lock in place.

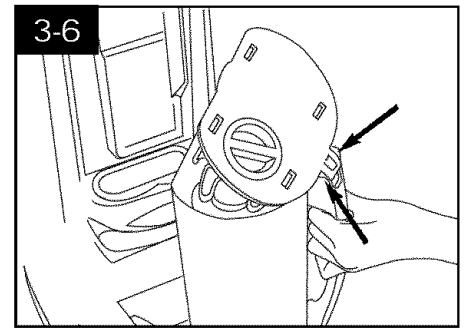

The dirt cup lid is designed with a "breakaway" feature which allows it to snap free if it is pushed open too far.

To reattach, align hinges of lid with slots in handle area of dirt cup. Push lid down to snap in place.

## Filter assembly

The HEPA cartridge filter and pre-filter are essentially self-shedding.

Turning the knob on the lid as described in "How to empty dirt cup" should sufficiently remove dust and fine particles from the HEPA cartridge filter.

The filter assembly can also be removed for additional cleaning.

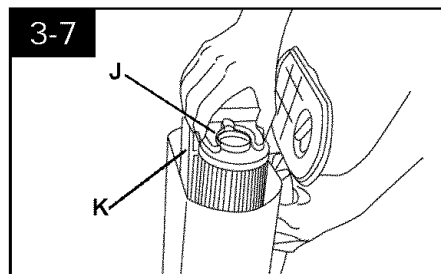

## How to clean filter assembly

Remove dirt cup and open dirt cup lid as described in "How to empty dirt cup."

Grasp pre-filter frame (J) and pull up firmly. Slide filter assembly out of cup.

As the pre-filter slides up, bristles (K) mounted inside the cup will brush dirt from the pre-filter into the cup.

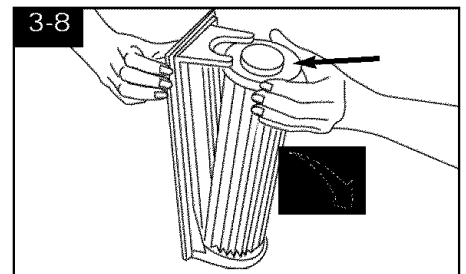

Grasp end of HEPA cartridge filter and pull it away from pre-filter. Remove cartridge from assembly.

The pre-filter can be cleaned with a brush and then rinsed with water. Allow pre-filter to dry thoroughly.

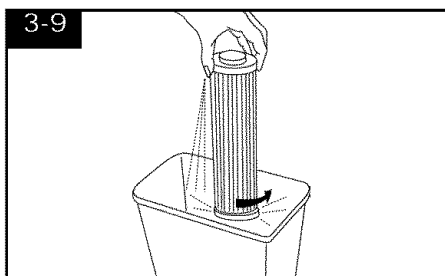

The HEPA cartridge filter can be cleaned by tapping either of the ends. **DO NOT tap soft pleated sides of HEPA cartridge filter as this could damage the filter.**

Tap filter until no more dust particles fall from the filter.

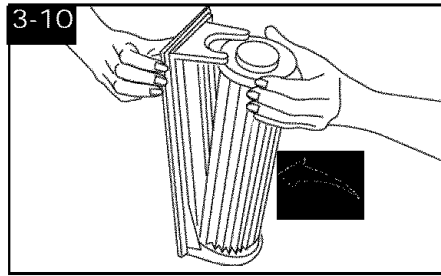

**To re-assemble filter assembly,** place large knob of HEPA cartridge filter in hole on bottom of pre-filter.

Snap top of HEPA cartridge filter into place.

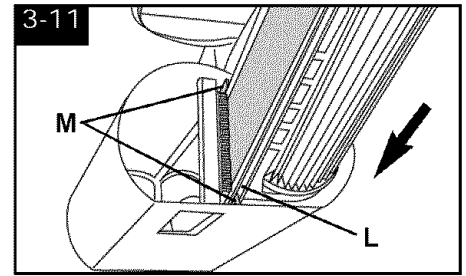

Align grooves (L) on pre-filter frame with ribs (M) in dirt cup.



3-12

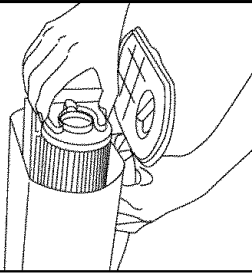

Slide filter assembly down into cup until a light snap is felt. Gently pull up on assembly to ensure that it is seated properly in the cup. Ensure that no part of pre-filter screen extends above top edge of dirt cup.

Close lid and return cup to cleaner (Fig. 3-5).

**Note:** If dirt cup lid does not close all the way, first ensure that filter assembly is pushed down all the way. Then, turn knob on lid slightly until lid closes (see Fig. 3-3).

3-13

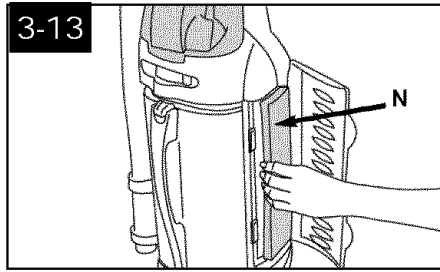

## Final filter

### Replacing final filter

The **final filter** assists in the filtration process to return clean air to the room.

To replace this filter when it becomes dirty, open the door on the side of the cleaner. Remove filter (N) and discard.

Reposition new filter on the side of cleaner. Make sure the white side of the filter faces outward. Close door.

Should you want to replace this filter, ask for part **No. 40110006**.

**Do not operate cleaner without the filter in place.**

3-14

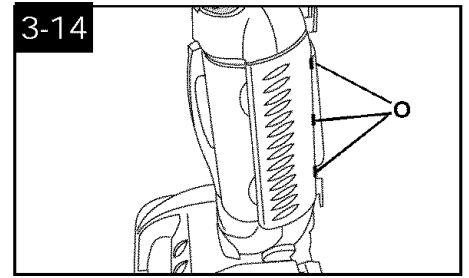

## Reattaching filter door

The filter door is designed with a "break-away" feature which allows it to snap free if it is pushed open too far.

To reattach, align hinges (O) of cover with slots on sides of filter area.

Press door back into place.

## Check brush roll channels

Because your cleaner picks up so well, we strongly recommend you check for debris accumulation in the channels next to the brush roll **when you check the filters**. Removing this debris will help maintain your cleaner's excellent pick up and suction. Remove debris as follows:

### Disconnect cleaner from electrical outlet.

Check for debris accumulation by removing bottom plate (Fig. 3-18) and looking in the channels next to the brush roll (Fig. 3-27).

Remove any accumulation.

Reposition bottom plate (Fig. 3-22).

## Headlight replacement

### What to buy

This cleaner uses a 12 volt, wedge base type 912 bulb, Hoover **part No. 27313101**.

3-15

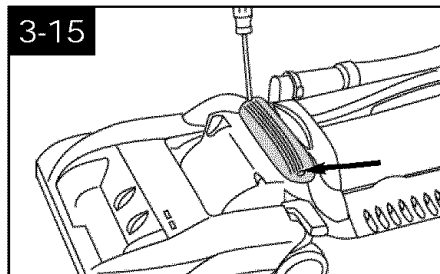

## Removing lens

### Disconnect cleaner from electrical outlet.

Using a screwdriver, remove the two screws as shown and lift off lens.

3-16

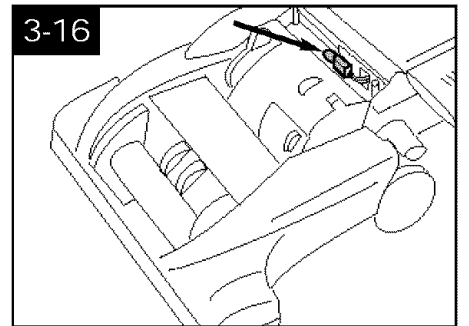

## Installing bulb

Pull old bulb straight out of socket. Push new bulb straight into socket until locked in place

**Excessive force is not required.**

3-17

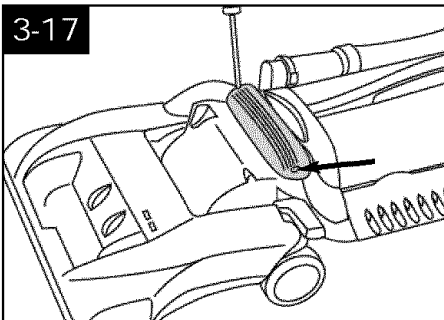

## Replacing lens

Reposition lens and secure with the two screws.

## Belt replacement

The belts are located under the bottom plate of the cleaner and should be checked from time to time to be sure they are in good condition.

The **flat (wide) belt** is described below; the other is described under "Brush roll replacement".

### When to replace

**Disconnect cleaner from electrical outlet.**

**Warning - Brush roll can start suddenly. Unplug cleaner when it is turned over.**

To check the flat belt, remove bottom plate as shown in Fig. 3-18. Replace belt if it is stretched, cut or broken.

### What to buy

To assure effective operation, use only genuine HOOVER belts with your cleaner. When purchasing a new belt, ask for flat belt Hoover **part No. 38528035**.

### Replacing flat belt

**Disconnect cleaner from electrical outlet.**

**Warning - Brush roll can start suddenly. Unplug cleaner when it is turned over.**

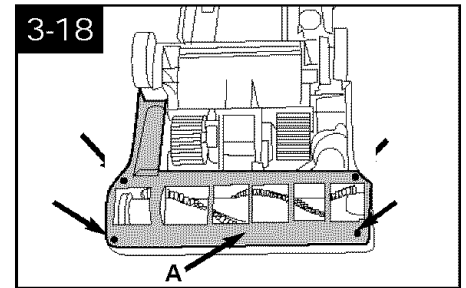

**Removing bottom plate**  
Place handle in low position and turn cleaner over so bottom side is up.

Remove the 4 screws as shown with a Phillips screw driver. Lift off bottom plate (A).

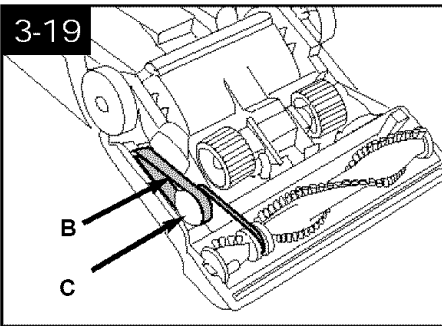

### Removing used belt

Flat belt (B) operates the self-propel feature and indirectly drives the brush roll.

Remove used belt (B) from large pulley (C) and discard.

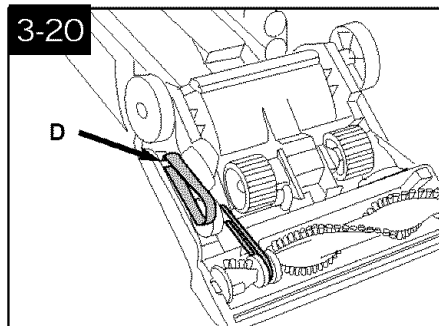

### Positioning back of belt

With lettering on outside of belt, slide new belt over motor shaft (D).

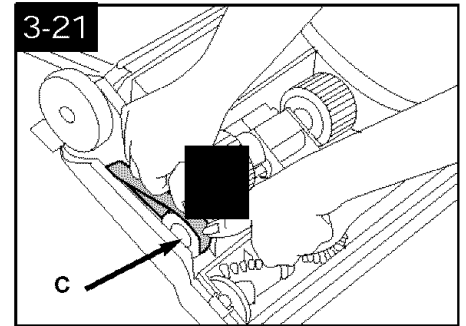

### Positioning front of belt

Place other end of belt over large pulley (C) while rolling the pulley in direction shown.

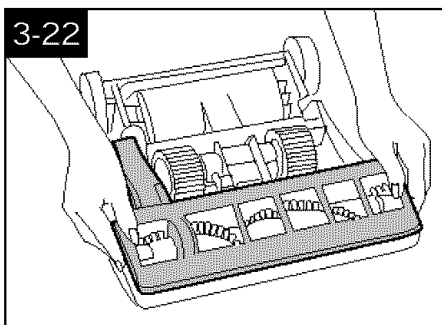

### Replacing bottom plate

Reposition bottom plate and 4 Phillips head screws. Tighten screws securely.

## The agitator brush roll

### When to replace

When agitator brushes are worn, the agitator should be replaced.

To check condition of brushes, **disconnect cleaner from electrical outlet**. Move edge of a card across bottom plate while turning agitator (Fig. 3-23). To maintain cleaning effectiveness, replace agitator if brushes do not touch card.

### What to buy

When purchasing a new agitator, ask for **HOOVER part No. 48414115**.

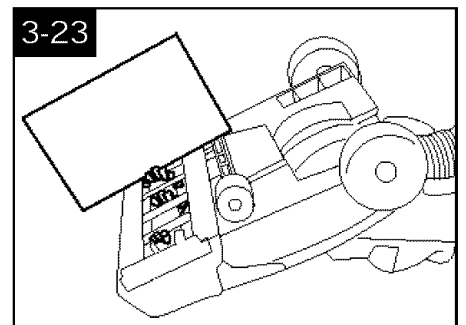

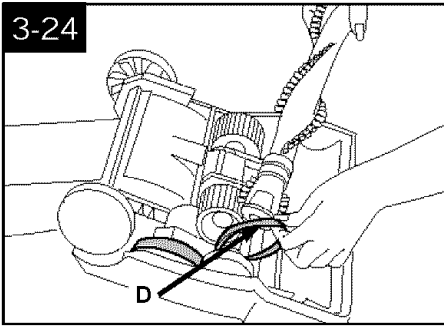

### Replacing brush roll

#### Removing brush roll

Slide brush roll control (Fig. 2-9) to "Hard" (OFF) position.

Turn cleaner over and remove bottom plate (Fig. 3-18).

Lift up brush roll and slide V-belt (D) off brush roll.

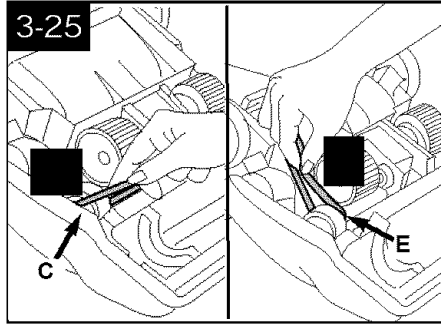

### Inspecting V-belt

The V-belt is designed to last for a long time and is not normally replaced. However, if V-belt is cracked, gouged or broken, now is a good time to replace it as follows.

Slide flat belt off large pulley as shown in Fig. 3-19.

To remove V-belt, slide **back of belt** over pulley (C). Then firmly **pull** on belt and "snap" it out.

Discard used belt. Replace with **HOOVER part No. 38528034**.

To install new belt (with lettering on outside of belt), **slide back of belt** over pulley and **pull front of belt toward groove (E) next to pulley**. Belt will "pop" into place.

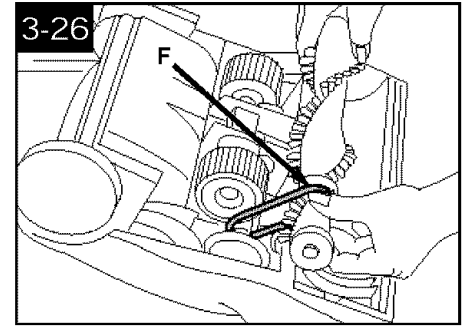

### Positioning belt on brush roll

**Before positioning belt onto brush roll, check for debris accumulation as described in Fig. 4-1.**

Insert brush roll through belt and position belt in groove (F) on brush roll.

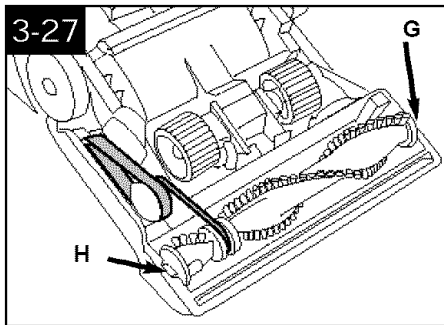

### Installing brush roll

Grasp brush roll and fit it into position by first sliding end, opposite the belt, into the rectangular slot (G) on side of cleaner.

Push other side of brush roll (H) into place. Belt may fit loosely when properly installed.

**Reposition flat belt and bottom plate** (Figs. 3-20 and 3-22).

### Powered hand tool

#### Agitator brush roll replacement

When agitator brush roll brushes are worn, the brush roll should be replaced. Ask for **HOOVER part No. 48414088**.

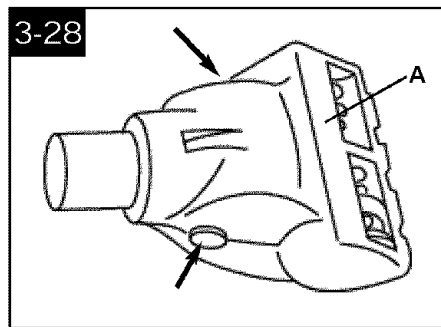

#### How to replace

1. Remove tool from hose and turn it so bottom faces up. Press the latches on either side of tool and remove bottom plate (A).

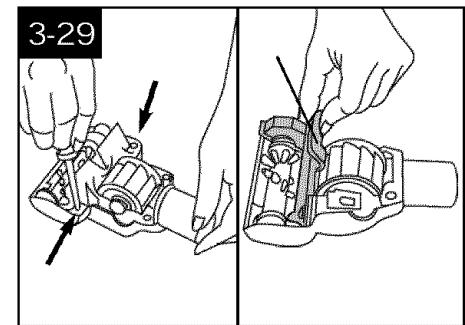

2. Unscrew the two Phillips screws and remove belt guard (B).

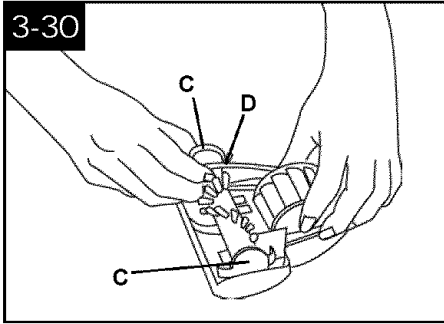

3. Remove agitator including end plates (C) and discard.
4. Inspect belt to ensure that it is in good condition. If belt is cracked, gouged or broken, replace it (see following section).
5. Insert brush roll through belt and position belt over gear teeth (D) on brush roll.

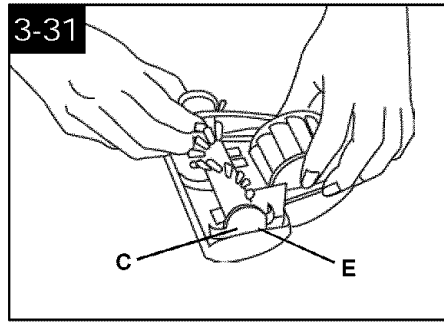

6. With curved ends down, slide end plates (C) of brush roll into slots (E) on tool.

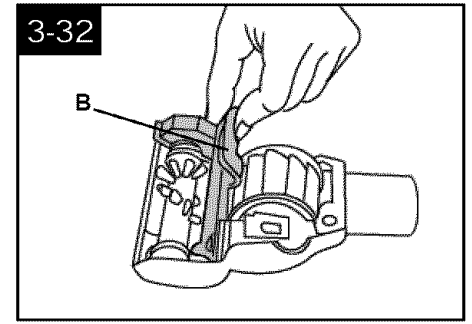

7. Replace belt guard (B) making sure not to pinch brush bristles in guard. Turn agitator, making sure it rotates freely. Replace and tighten screws.

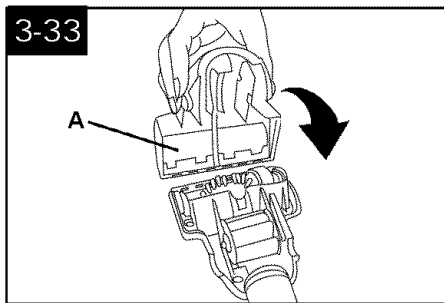

8. To replace bottom plate (A), insert the four tabs on edge of bottom plate into slots on front of tool. Pivot bottom plate down and snap closed.

## Powered hand tool Belt replacement

The powered hand tool belt is designed to last a long time and is not normally replaced. However, if the belt is cracked, gouged or broken, it should be replaced.

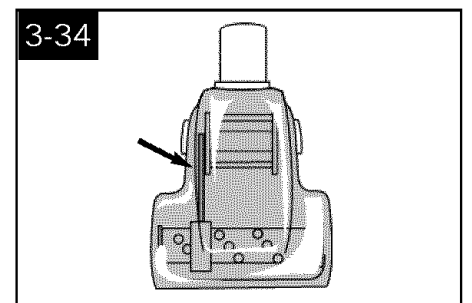

The belt can be seen through the top of the nozzle or by removing the bottom plate and belt guard (Figs. 3-28 and 3-29).

## Replacing belt

When replacing belt, ask for **HOOVER part No. 38528037**.

1. Remove bottom plate, belt guard and brush roll as described in Figs. 3-28 through 3-30.

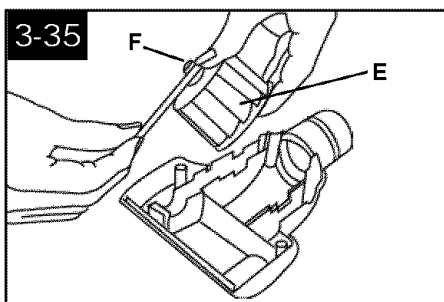

2. Grasp turbine (E) and pull firmly to remove.
3. Remove belt from turbine pulley (F). Replace with new belt.

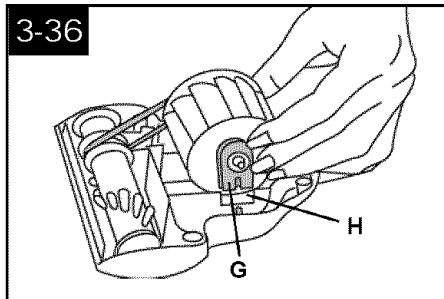

4. With flat sides of turbine retainers (G) pointing down, slide retainers into grooves (H) in tool housing and snap into place.
5. Replace brush roll, belt guard, and bottom plate as described in Figs. 3-30 through 3-33.

## Edge groomer replacement

### When to replace

The edge groomers, located on both sides of the nozzle, should be replaced when they are worn.

### What to buy

When purchasing edge groomers, ask for HOOVER **part No. 39511004**.

### How to replace

#### Disconnect cleaner from electrical outlet.

Remove bottom plate as described in "The belt" section (Fig.3-18).

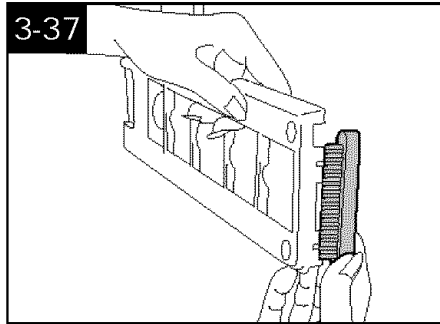

#### Installing groomers

Lift off both old edge groomers and slide new edge groomers into position as shown.

Reposition bottom plate and secure with (4) Phillips head screws.

## Lubrication

The motor is equipped with bearings which contain sufficient lubrication for the life of the motor. The addition of lubricant could cause damage. **Do not add lubricant to motor bearings.**

The agitator is equipped with two ball bearings that should be lubricated periodically by a Hoover Factory Service Center or an Authorized Hoover Warranty Service Dealer (Depot).

## Thermal protector

An internal thermal protector has been designed into your cleaner to protect it from overheating.

**When the thermal protector activates, the cleaner will stop running.** If this happens, proceed as follows:

1. Turn the cleaner OFF and disconnect it from the electrical outlet.
2. Check dirt cup pre-filter, HEPA cartridge filter and secondary and final filters for dirt accumulation.
3. Refer to "Clearing blockages" section.
4. **When cleaner is unplugged and the motor cools for 30 minutes**, the thermal protector automatically resets and cleaning may continue.

If the thermal protector continues to activate after following the above steps, your cleaner may need servicing (see "Service" section).

## Service

To obtain approved HOOVER service and genuine HOOVER parts, locate the nearest **Hoover Factory Service Center or Authorized Hoover Warranty Service Dealer (Depot)** by:

- checking the Yellow Pages under "Vacuum Cleaners - Household" OR -
- checking the list of Factory Service Centers provided with this cleaner OR -
- calling 1-800-944-9200 for an automated referral of authorized service outlet locations (U.S. only) OR -
- checking the Service section of The Hoover Company on-line at **www.hoover.com**

**Do not** send your cleaner to The Hoover Company in North Canton for service, this will only result in delay.

If further assistance is needed, contact The Hoover Company Consumer Response Center, North Canton, Ohio 44720, Phone: 330-499-9499.

**In Canada**, contact Hoover Canada, Burlington, Ontario L7R 4A8, Phone: 1-800-263-6376.

Always identify your cleaner by the **complete** model number when requesting information or ordering parts. (The model number appears on the bottom of the cleaner.)

## Hoover Cleaning Performance

This Hoover Cleaning Performance System is for comparing the relative progressive performance of **Hoover uprights only** and not for comparison with any other brands. The majority of this rating is based upon the American Society for Testing and Materials (ASTM) Carpet Cleaning Effectiveness Testing (ASTM Test F608). Other performance factors include Hose Power (ASTM Test F558), Surface Litter Cleaning, Hard Floor Cleaning, Edge Cleaning, Air Filtration and Cleaning Width.

## 4. If you have a problem

If a minor problem occurs, it usually can be solved quite easily when the cause is found by using the check list below.

### Problem: Cleaner won't run

#### Possible cause

#### Possible solution

- **Not firmly plugged in**
- Plug unit in firmly.
- **No voltage in wall plug**
- Check fuse or breaker.
- **Blown fuse/tripped breaker**
- Replace fuse/reset breaker.
- **Thermal protector activated**
- Allow cleaner to cool for 30 minutes (this will reset the thermal protector)

### Problem: Cleaner won't pick up

#### Possible cause

#### Possible solution

- **Broken or worn belt**
- Replace belt.
- **Agitator brush roll worn**
- Replace brush roll.
- **Dirt cup full**
- Empty dirt cup.
- **Incorrect carpet height setting**
- Move nozzle control knob to lower setting.
- **Blockage in air flow passage**
- Clear blockage.
- **HEPA cartridge filter clogged**
- Clean HEPA cartridge filter by either tapping the side of the dirt cup or removing the cartridge filter as described in the "Filter assembly" section.
- **Pre-filter clogged**
- Clean pre-filter as described in "Filter assembly" section.
- **Dirt cup not properly installed and latched**
- Position dirt cup properly and lock latch (Fig. 3-5).
- **Dirt cup lid not positioned properly or missing**
- Ensure that dirt cup lid is properly positioned.
- **Filter assembly not assembled properly**
- Ensure that filter assembly is positioned properly (Figs. 3-10 to 3-12).

### Problem: Cleaner hard to push

#### Possible cause

#### Possible solution

- **Incorrect carpet height setting**
- Move nozzle control knob to a higher setting.

### Problem: Cleaning tools won't pick up

#### Possible cause

#### Possible solution

- **Cleaner handle not in upright position**
- Ensure that cleaner handle is locked in upright position.
- **Blockage in hose**
- Clear blockage.

### Problem: Cleaner won't self-propel

#### Possible cause

#### Possible solution

- **Flat belt broken or worn**
- Replace belt.
- **Self-propel button in OFF position**
- Slide button to ON.

### Problem: Brush roll not turning

#### Possible cause

#### Possible solution

- **Brush roll in OFF position**
- Move brush roll control to ON position (carpet)
- **Flat belt broken or worn**
- Replace belt.

### Problem: Visible dirt leaking through final filter

#### Possible cause

#### Possible solution

- **Filter assembly not installed properly**
- Remove filter assembly from dirt cup and ensure that HEPA cartridge filter is properly attached to pre-filter screen and that entire filter assembly is properly repositioned inside dirt cup (Fig. 3-10 through 3-12).

### Problem: Dirt inside dirt cup stops spinning

**Note:** Heavy debris may settle to the bottom of the dirt cup and prevent the dirt from spinning without affecting cleaning performance. The cleaner can continue to be used even if the dirt is not spinning inside the dirt cup. However, if the dirt does stop spinning AND there is a noticeable decrease of performance, check the items under "Cleaner won't pick up".

### Problem: Powered hand tool brush roll won't turn

#### Possible Cause

#### Possible Solution

- **Too much pressure being applied to tool**
- Continue using tool applying *light* pressure.
- **Blockage in turbine channel**
- Remove blockage.
- **Broken or worn belt**
- Replace belt.
- **Low cleaner suction**
- Check items under "Cleaner suction low".

## Clearing blockages Disconnect cleaner from electrical outlet.

**Warning - Brush roll can start suddenly. Unplug cleaner when it is turned over.**

Low suction or pick up may be due to a blockage in the system. Refer to the following steps to check for blockages **continuing with each step until the blockage is found:**

A. If a blockage occurs during floor cleaning:

Turn cleaner OFF and disconnect from electrical outlet.

1. Check fullness of dirt cup and filter assembly; empty cup and clean filters if needed.

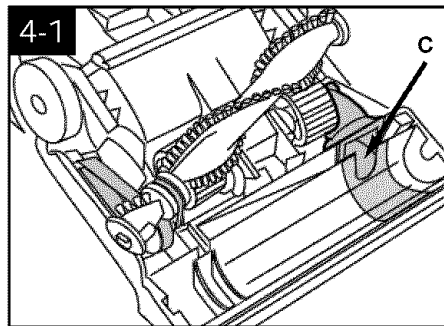

2. Turn cleaner OFF and unplug.

3. Remove bottom plate, belt and agitator (see "The belt" section).

Look into opening (C) for blockages and remove.

4. Remove agitator shield and remove any loose debris which may have accumulated under it.

B. If a blockage occurs during tool use:

Turn cleaner OFF and disconnect from electrical outlet.

1. Look into hose end and remove any blockage.

**Note:** Electrical parts are enclosed in the cleaner. Do not remove any screws. If blockage cannot be removed through existing openings, take the cleaner to a Hoover Factory Service Center or an Authorized Hoover Warranty Service Dealer (Depot).

C. If blockage occurs during powered hand tool use:

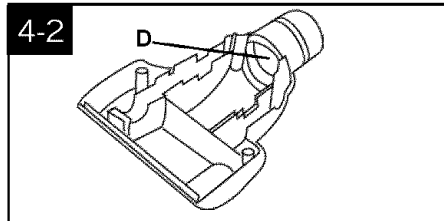

1. Disconnect powered hand tool from hose. Remove bottom plate, belt guard and turbine as described in Figs. 3-28, 3-29 and 3-35.

Remove any blockage from turbine channel (D).

Replace belt turbine, brush roll, belt guard and bottom plate.

## Full Two Year Warranty (Domestic Use)

Your HOOVER® appliance is warranted in normal household use, in accordance with the Owner's Manual against original defects in material and workmanship for a period of two full years from date of purchase. This warranty provides, at no cost to you, all labor and parts to place this appliance in correct operating condition during the warranted period. This warranty applies when the appliance is purchased in the United States including its territories and possessions, or in Canada or from a U. S. Military Exchange. Appliances purchased elsewhere are covered by a limited two year warranty which covers the cost of parts only. This warranty does not apply if the appliance is used in a commercial or rental application.

Warranty service can only be obtained by presenting the appliance to one of the following authorized warranty service outlets. Proof of purchase will be required before service is rendered.

1. Hoover Factory Service Centers.
2. Hoover Authorized Warranty Service Dealers (Depots).

**For an automated referral of authorized service outlets in the U.S.A., phone 1-800-944-9200 OR**

**visit The Hoover Company on-line at [www.hoover.com](http://www.hoover.com)**

This warranty does not cover pick up, delivery, or house calls; however, if you mail your appliance to a Hoover Factory Service Center for warranty service, transportation will be paid one way.

While this warranty gives you specific legal rights, you may also have other rights which vary from state to state.

If further assistance is needed, or if there are questions concerning this warranty or the availability of warranty service outlets, write or phone the Consumer Response Center, The Hoover Company, 101 East Maple St., North Canton, Ohio 44720.  
Phone 1-330-499-9499.

In Canada, contact Hoover Canada, Burlington, Ontario L7R 4A8,  
1-800-263-6376.

