

Mini HI-FI Component System

Operating Instructions

Owner's Record

The model and serial numbers are located on the rear of the unit. Record the serial number in the space provided below. Refer to them whenever you call upon your Sony dealer regarding this product.

Model No. _____ Serial No. _____



**MHC-GX555/GX355/GX255
MHC-RG575S/RG475S/RG470/
RG270/RG170**

WARNING

To prevent fire or shock hazard, do not expose the unit to rain or moisture.

To prevent fire, do not cover the ventilation of the apparatus with news papers, table-cloths, curtains, etc. And don't place lighted candles on the apparatus.

To prevent fire or shock hazard, do not place objects filled with liquids, such as vases, on the apparatus.

Do not install the appliance in a confined space, such as a bookcase or built-in cabinet.

CLASS 1 LASER PRODUCT
LUOKAN 1 LASERLAITE
KLASS 1 LASERAPPARAT

This appliance is classified as a CLASS 1 LASER product. This marking is located on the rear exterior.



Don't throw away the battery with general house waste, dispose of it correctly as chemical waste.

NOTICE FOR THE CUSTOMERS IN THE U.S.A.

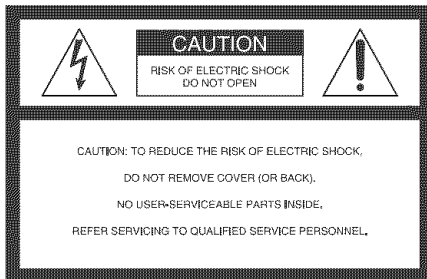

This symbol is intended to alert the user to the presence of uninsulated "dangerous voltage" within the product's enclosure that may be of sufficient magnitude to constitute a risk of electric shock to persons.



This symbol is intended to alert the user to the presence of important operating and maintenance (servicing) instructions in the literature accompanying the appliance.

CAUTION

The use of optical instruments with this product will increase eye hazard.

WARNING

This equipment has been tested and found to comply with the limits for a Class B digital device, pursuant to Part 15 of the FCC Rules. These limits are designed to provide reasonable protection against harmful interference in a residential installation. This equipment generates, uses, and can radiate radio frequency energy and, if not installed and used in accordance with the instructions, may cause harmful interference to radio communications. However, there is no guarantee that interference will not occur in a particular installation. If this equipment does cause harmful interference to radio or television reception, which can be determined by turning the equipment off and on, the user is encouraged to try to correct the interference by one or more of the following measures:

- Reorient or relocate the receiving antenna.
- Increase the separation between the equipment and receiver.
- Connect the equipment into an outlet on a circuit different from that to which the receiver is connected.
- Consult the dealer or an experienced radio/TV technician for help.

CAUTION

You are cautioned that any changes or modifications not expressly approved in this manual could void your authority to operate this equipment.

Note to CATV system installer:

This reminder is provided to call the CATV system installer's attention to Article 820-40 of the NEC that provides guidelines for proper grounding and, in particular, specifies that the cable ground shall be connected to the grounding system of the building, as close to the point of cable entry as practical.

NOTICE FOR THE CUSTOMERS IN CANADA

CAUTION

The use of optical instruments with this product will increase eye hazard.

Except for European and Russian models



ENERGY STAR® is a U.S. registered mark. As an ENERGY STAR® partner, Sony Corporation has determined that this product meets the ENERGY STAR® guidelines for energy efficiency.

Table of Contents

How to use this manual.....	4
Playable discs.....	4

Getting Started

Hooking up the system.....	6
Setting the clock.....	9

CD/MP3 – Play

Loading a disc.....	10
Playing a disc.....	10
— Normal Play/Shuffle Play	
Playing repeatedly.....	12
— Repeat Play	
Creating your own program.....	13
— Program Play	

Tuner

Presetting radio stations.....	14
Listening to the radio.....	15
— Preset Tuning	
— Manual Tuning	
Using the Radio Data System (RDS)....	16
(European model only)	

Tape – Play

Loading a tape.....	17
Playing a tape.....	17

Tape – Recording

Recording your favorite CD tracks on a tape.....	18
— CD-TAPE Synchro Recording	
Recording on a tape manually.....	18
— Manual Recording	

Sound Adjustment

Adjusting the sound.....	19
Using the sub woofer.....	19
(MHC-GX555/RG575S/RG475S only)	
Selecting the sound effect.....	19
Adjusting the graphic equalizer and storing.....	20
Selecting the surround effect.....	20
Singing along: Karaoke.....	21
(Latin American model only)	

Timer

Falling asleep to music.....	22
— Sleep Timer	
Waking up to music.....	22
— Play Timer	
Timer recording radio programs.....	23
— Rec Timer	

Display

Turning off the display.....	24
— Power Saving Mode	
Viewing information about the disc in the display.....	25
Changing the Power illuminator.....	26
Viewing the tuner information in the display.....	26

Optional Components

Hooking up optional components.....	27
-------------------------------------	----

Troubleshooting

Problems and remedies.....	28
Messages.....	31

Additional Information

Precautions.....	32
Specifications.....	34
List of button locations and reference pages.....	40







How to use this manual

This manual mainly explains operations using the remote, but the same operations can also be performed using the buttons on the unit having the same or similar names.

Playable discs

You can play back the following discs on this system. Other discs cannot be played back.

List of playable discs

Format of discs	Disc logo
Audio CDs	
CD-Gs* (CD-Graphics)	
CD-R/CD-RW (audio data/MP3 files)	   

* Playback is possible only on Mexican model.

Discs that this system cannot play

- CD-ROMs
- CD-Rs/CD-RWs other than those recorded in the following formats:
 - music CD format
 - MP3 format that conforms to ISO9660¹⁾ Level 1/Level 2, Joliet or Multi Session²⁾
- Discs with non-standard shapes (e.g., heart, square, star) cannot be played on this unit. Attempting to do so may damage the unit. Do not use such discs.
- A disc with paper or stickers on it.
- A disc that has the adhesive, cellophane tape, or a sticker still left on it.

1) ISO9660 Format

The most common international standard for the logical format of files and folders on a CD-ROM. There are several specification levels. In Level 1, file names must be in the 8.3 format (no more than eight characters in the name, no more than three characters in the extension “.MP3”) and in capital letters. Folder names can be no longer than eight characters. There can be no more than eight nested folder levels. Level 2 specifications allow file names and folder names up to 31 characters long. Each folder can have up to 8 trees. For Joliet in the expansion format (file and folder names can have up to 64 characters) make sure of the contents of the writing software, etc.

2) Multi Session

This is a recording method that enables adding of data using the Track-At-Once method. Conventional CDs begin at a CD control area called the Lead-in and end at an area called Lead-out. A Multi Session CD is a CD having multiple sessions, with each segment from Lead-in to Lead-out regarded as a single session.

CD-Extra: This format records audio (audio CD data) on the tracks in session 1 and data on the tracks in session 2.

Mixed CD: This format records data on the first track and audio (audio CD data) on the second and subsequent tracks of a session.

Notes on CD-R and CD-RW

- Some CD-Rs or CD-RWs cannot be played on this system depending upon the recording quality or physical condition of the disc, or the characteristics of the recording device. Furthermore, the disc will not play if it has not been correctly finalized. For more information, see the operating instructions for the recording device.
- Discs recorded on CD-R/CD-RW drives may not be played back because of scratches, dirt, recording condition or the driver's characteristics.
- CD-R and CD-RW discs recorded in multi-session that have not ended by "closing the session" are not supported.
- The system may be unable to play MP3 format files that do not have the ".MP3" extension.
- Attempting to play non-MP3 format files that have the ".MP3" extension may result in noise or malfunction.
- With formats other than ISO9660 Level 1 and 2, folder names or file names may not be displayed correctly.
- The following discs take a longer time to start playback.
 - a disc recorded with complicated tree structure.
 - a disc recorded in Multi Session.
 - a disc to which data can be added (non-finalized disc).

Music discs encoded with copyright protection technologies

This product is designed to playback discs that conform to the Compact Disc (CD) standard. Recently, various music discs encoded with copyright protection technologies are marketed by some record companies. Please be aware that among those discs, there are some that do not conform to the CD standard and may not be playable by this product.

Cautions when playing a disc that is recorded in Multi Session

- If the disc begins with a CD-DA session, it is recognized as a CD-DA (audio) disc, and playback continues until an MP3 session is encountered.
- If the disc begins with an MP3 session, it is recognized as an MP3 disc, and playback continues until a CD-DA (audio) session is encountered.
- The playback range of an MP3 disc is determined by the tree structure of files produced by analyzing of the disc.
- A disc with a mixed CD format will be recognized as a CD-DA (audio) disc.

Getting Started

Hooking up the system

Perform the following procedures **1** to **6** to hook up your system using the supplied cords and accessories. A model equipped with a sub woofer is used for illustration purpose.

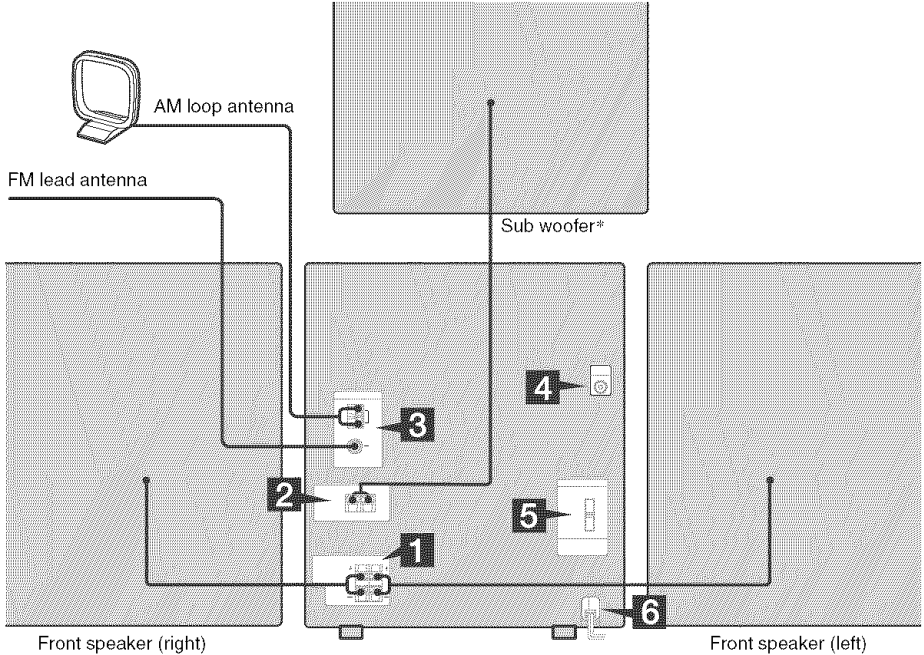

* MHC-GX555/RG575S/RG475S only

1 Connect the front speakers.

Connect the right and left speaker cords to the SPEAKER terminals as shown below.

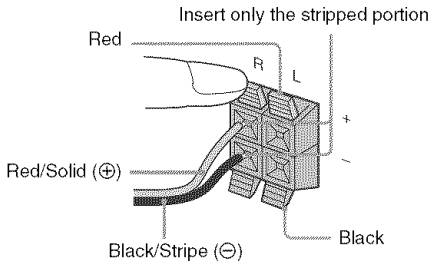

2 Connect the sub woofer. (MHC-GX555/RG575S/RG475S only)

Connect the speaker cords to the SUBWOOFER OUT terminal as shown below.

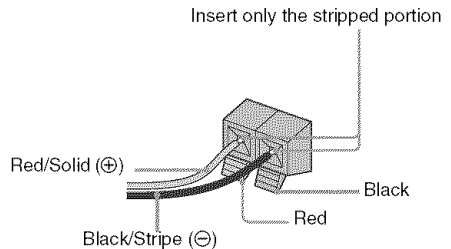

3 Connect the FM and AM antennas.

Set up the AM loop antenna, then connect it.

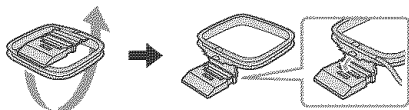
**Plug type A**

AM loop antenna

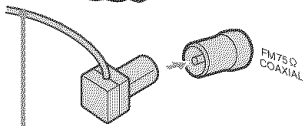
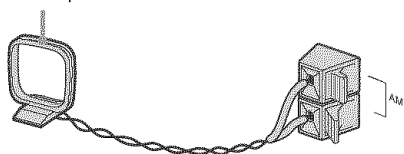

Extend the FM lead antenna horizontally

Plug type B

AM loop antenna

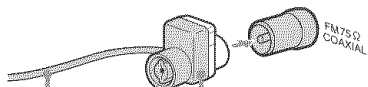

Extend the FM lead antenna horizontally

North American model:
Connect white side.
Other models:
Connect brown side.

Note

To prevent noise pickup, keep the antennas away from the speaker cords.

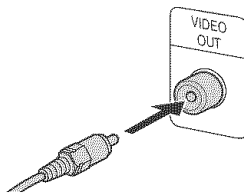
4 (Mexican model only) Connect the video input jack of your TV to the VIDEO OUT jack with the video cable (supplied).**When using a TV**

Turn on the TV and select the video input so that you can view the pictures from this system.

Note

Mexican model is designed to play back only CD-Gs recorded in the NTSC color system. If you play a CD-G recorded in other color system, the pictures may not be displayed correctly.

5 For models with a voltage selector, set VOLTAGE SELECTOR to the local power line voltage.

Refer to the print on your system's VOLTAGE SELECTOR for available settings.

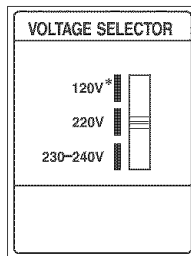

* Saudi Arabian model: 120 – 127 V

6 Connect the power cord to a wall outlet.

The demonstration appears in the display. When you press **I/⏻**, the system turns on and the demonstration automatically ends. If the plug does not fit the wall socket, detach the supplied plug adaptor (only for models equipped with an adaptor).

Inserting two R6 (size AA) batteries into the remote

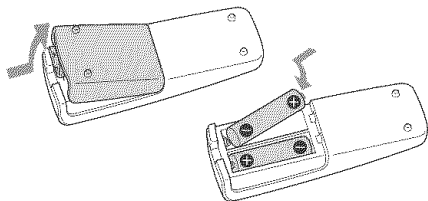

Note

If you do not use the remote for a long period of time, remove the batteries to avoid possible damage from battery leakage and corrosion.

Tip

With normal use, the batteries should last for about six months. When the remote no longer operates the system, replace both batteries with new ones.

Attaching the speaker pads

Attach the supplied speaker pads to the bottom of the speakers to stabilize the speakers and prevent them from slipping.

Front speaker (Left (4)/Right (4))
Sub woofer (4)*

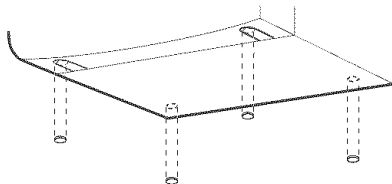

* MHC-GX555/RG575S/RG475S only

When carrying this system

Perform the following procedure to protect the CD mechanism. Use buttons on the unit for the operation.

- 1** Press **I/⏻** to turn on the system, then press **CD** to switch the function to CD.
- 2** Make sure that all discs are removed from the system.
- 3** Hold down **CD** and then press **I/⏻** until "STANDBY" appears.
After a few seconds later, "STANDBY" disappears and "LOCK" appears.
- 4** Unplug the power cord.

Placing the sub woofer (MHC-GX555/RG575S/RG475S only)

To obtain a better bass reproduction, we recommend you to place the sub woofer on a solid floor where resonance is unlikely to occur.

Notes

- Always place the sub woofer vertically, keeping it a few centimeters away from the wall.
- If the sub woofer is placed in the center of a room, the bass could be extremely weakened. This is due to the influence of the standing wave of the room. If this happens, move the sub woofer away from the center of the room or eliminate the cause of the standing wave, by placing a bookshelf against the wall, etc.

Setting the clock

Use buttons on the remote for the operation.

- 1 Press I/⏻ to turn on the system.
- 2 Press CLOCK/TIMER SET.
- 3 Press ◀◀ or ▶▶ repeatedly to set the hour.
- 4 Press ENTER.
- 5 Press ◀◀ or ▶▶ repeatedly to set the minute.
- 6 Press ENTER.

The clock starts working.

To adjust the clock

- 1 Press CLOCK/TIMER SET.
- 2 Press ◀◀ or ▶▶ repeatedly to select "CLOCK SET", then press ENTER.
- 3 Do the same procedures as step 3 to 6 above.

Notes

- The clock settings are canceled when you disconnect the power cord or if a power failure occurs.
- You cannot set the clock in Power Saving Mode (page 24).

CD/MP3 – Play

Loading a disc

Use buttons on the unit for the operation.

- 1 Press **▲**.
- 2 Place a disc with the label side up on the disc tray.

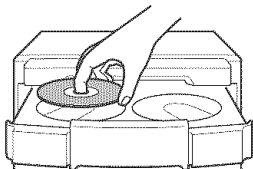

To insert additional discs, press DISC SKIP/EX-CHANGE to rotate the disc tray.

- 3 Press **▲** again to close the disc tray.

Notes

- Do not use a disc with tape, seals or paste on it as this may cause malfunction.
- Do not forcibly press the disc tray closed with your finger, as this may cause malfunction.

Playing a disc

— Normal Play/Shuffle Play

This system lets you play audio CDs, CD-Gs* and discs with MP3 audio tracks.

* CD-Gs (CD-Graphics) can only be played on Mexican model.

You can enjoy the video images recorded on CD-Gs by connecting the system to a TV (see step 4 of “Hooking up the system” (page 6)).

Example: When a disc is loaded

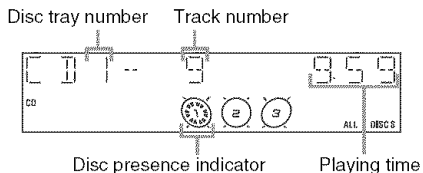

- 1 Press **CD** (or **FUNCTION** repeatedly) to switch the function to **CD**.

2 Press **PLAY MODE** repeatedly in stop mode until the mode you want appears in the display.

Select	To play
ALL DISCS (Normal Play)	All discs in the disc tray continuously.
IDISC (Normal Play)	The tracks on the disc you have selected in original order.
ALBM (Normal Play)	All MP3 audio tracks in the album on the disc you have selected in original order. When playing a non-MP3 disc, Album Play performs the same operation as IDISC Play.
ALL DISCS SHUF (Shuffle Play)	The tracks on all discs in random order.
IDISC SHUF (Shuffle Play)	The tracks on the disc you have selected in random order.
ALBM SHUF (Shuffle Play)	The MP3 audio tracks in the album on the disc you have selected in random order. When playing a non-MP3 disc, Album Shuffle Play performs the same operation as IDISC SHUF Play.
PGM (Program Play)	The tracks on the disc in the order you want them to be played (see “Creating your own program” on page 13).

3 Press **▶**.

Other operations

To	Do this
Stop play	Press ■ .
Pause	Press ⏸ . Press again to resume play.
Select a track	Press ⏮ or ⏭ repeatedly (or turn ⏪ ⏩ on the unit).
Select an album of MP3	Press ALBUM + or – repeatedly after step 2.
Find a point in a track (except for CD-Gs)	Keep pressing ⏮ or ⏭ during playback and release it at the desired point.
Select a disc in stop mode	Press DISC SKIP (or DISC 1 – 3 or DISC SKIP/EX-CHANGE on the unit).
Switch to CD function from other function	Press DISC 1 – 3 on the unit (Automatic Source Selection).
Exchange other discs while playing	Press DISC SKIP/EX-CHANGE on the unit.
Remove a disc	Press ▲ on the unit.

Notes

- On Mexican model, you cannot perform the following operations
 - selecting the graphic channels of CD-Gs
 - displaying CD-G images with fading effects
- You cannot change the play mode during playback.
- Some time may be needed to start playback of discs recorded in complex configurations such as many layers.
- When the disc is inserted, the player reads all the tracks on that disc. If there are many albums or non-MP3 audio tracks on the disc, it may take a long time for play to begin or for the next MP3 audio track to start play.
- Do not save unnecessary albums or tracks other than MP3 ones in the disc to be used for MP3 listening. We recommend that you do not save other types of tracks or unnecessary albums on a disc that has MP3 audio tracks.
- An album that does not include an MP3 audio track is skipped.
- Maximum number of albums: 150 (including root folder)
- Maximum number of MP3 audio tracks: 255
- The maximum number of MP3 audio tracks and albums that can be contained on a single disc is 300.
- Playback is possible up to 8 levels.
- MP3 audio tracks are played back in the order that they are recorded on the disc.
- Depending on the encoding/writing software, recording device, or the recording media used at the time an MP3 audio track is recorded, you may encounter such problems as disabled playback, sound interruptions, and noise.

Note

When disc access takes a long time, set “CD POWER ON” by CD power manage function (page 15).

Playing repeatedly

— Repeat Play

You can play all the tracks or a single track on a disc repeatedly.

Press **REPEAT** repeatedly until “**REP**” or “**REP1**” appears.

REP: For all the tracks on a disc up to five times.

REP1: For a single track only.

To cancel Repeat Play

Press **REPEAT** repeatedly until both “**REP**” and “**REP1**” disappear.

Notes

- You cannot select “**REP**” and “**ALL DISCS SHUF**” at the same time.
- When you select “**REP1**”, that track is repeated endlessly until “**REP1**” is canceled.

Creating your own program

— Program Play

You can make a program of up to 25 steps from all the discs in the order you want to play them. You can synchro record the programmed tracks onto a cassette tape (page 18).

- 1** Press **CD** (or **FUNCTION** repeatedly) to switch the function to **CD**.
- 2** Press **PLAY MODE** repeatedly in stop mode until “**PGM**” appears.
- 3** Press **DISC SKIP** (or **DISC 1 – 3** or **DISC SKIP/EX-CHANGE** on the unit) to select a disc.
- 4** Press **◀◀** or **▶▶** repeatedly (or turn **◀◀ ▶▶** on the unit) until the desired track number appears.

When programming the MP3 audio tracks, press **ALBUM +** or **-** repeatedly to select the desired album, then press **◀◀** or **▶▶** repeatedly (or turn **◀◀ ▶▶** on the unit) until the desired track number appears.

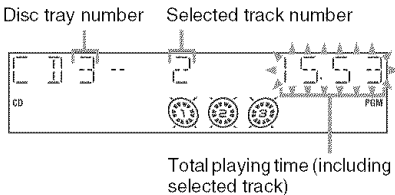

5 Press **ENTER**.

The track is programmed.
The program step number appears, followed by the total playing time.

6 Program additional tracks.

To program	Repeat steps
Other tracks on the same disc	4 and 5
Other tracks on other discs	3 to 5

7 Press **▶**.

Program Play starts.

Other operations

To	Do this
Cancel Program Play	Press PLAY MODE repeatedly in stop mode until “ PGM ” disappears.
Clear a track from the end	Press CLEAR in stop mode.

Tips

- The program you made remains after Program Play finishes. To play the same program again, press **CD** (or **FUNCTION** repeatedly) to switch the function to **CD**, then press **▶**. However, the program is cleared when you open the disc tray.
- “-- --” appears when the total CD program time exceeds 100 minutes, or when you select an MP3 audio track.

Tuner

Presetting radio stations

You can preset up to 20 FM stations and 10 AM stations. You can then tune in any of those stations simply by selecting the corresponding preset number.

Automatic tuning preset

You can automatically tune in all of the stations that can be received in your area and then store the radio frequency of the desired stations.

- 1 Press **TUNER BAND** (or **FUNCTION** repeatedly) to switch the function to **TUNER**.
- 2 Press **TUNER BAND** repeatedly to select “FM” or “AM”.
- 3 Press **TUNING MODE** repeatedly until “AUTO” appears in the display.
- 4 Press **+ or –** (or turn – **TUNING +** on the unit).

The frequency changes as the system scans for a station. Scanning stops automatically when a station is tuned in. At that time, “TUNED” and “STEREO” (for an FM stereo program) appear.

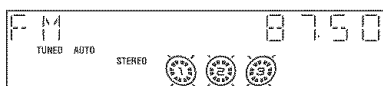

If “TUNED” does not appear and the scanning does not stop

Set the frequency of the desired radio station as described in steps 3 through 8 of “Manual tuning preset”.

- 5 Press **TUNER MEMORY**.
A preset number appears.

Preset number

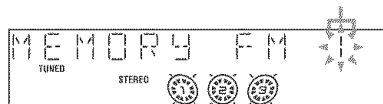

- 6 Press **+ or –** (or turn – **TUNING +** on the unit) repeatedly to select the desired preset number.
- 7 Press **ENTER**.
- 8 Repeat steps 2 through 7 to store other stations.

Manual tuning preset

You can manually tune in and store the radio frequency of the desired stations.

- 1 Press **TUNER BAND** (or **FUNCTION** repeatedly) to switch the function to **TUNER**.
- 2 Press **TUNER BAND** repeatedly to select “FM” or “AM”.
- 3 Press **TUNING MODE** repeatedly until “AUTO” and “PRESET” disappear from the display.
- 4 Press **+ or –** (or turn – **TUNING +** on the unit) repeatedly to tune in the desired station.
- 5 Press **TUNER MEMORY**.
A preset number appears.
- 6 Press **+ or –** (or turn – **TUNING +** on the unit) repeatedly to select the desired preset number.
- 7 Press **ENTER**.
- 8 Repeat steps 2 through 7 to store other stations.

Other operations

To	Do this
Tune in a station with a weak signal	Follow the procedure described in “Manual tuning preset”.
Set another station to the existing preset number	Start over from step 2. After step 5, press + or – (or turn – TUNING + on the unit) repeatedly to select the preset number you want to store the other station.

To change the AM tuning interval (except for European, Russian and Saudi Arabian models)

The AM tuning interval is factory-preset to 9 kHz (or 10 kHz for some areas). To change the AM tuning interval, tune in any AM station first, then turn off the system. While holding TUNING MODE on the unit, press I/⏻ on the unit. When you change the interval, all the AM preset stations are erased. To reset the interval, repeat the same procedure.

Note

You cannot change the AM tuning interval in Power Saving Mode (page 24).

Tips

- The preset stations are retained for about a day even if you disconnect the power cord or if a power failure occurs.
- To improve broadcast reception, adjust the supplied antennas, or connect a commercially available external antenna.

To improve tuner reception

When tuner reception is poor, set CD player power off by CD power manage function. CD power is factory set to on.

Use buttons on the unit for the operation.

- 1 Press CD to switch the function to CD.
- 2 Press I/⏻ to turn off the system.
- 3 After "STANDBY" stops flashing, press I/⏻ while holding ■. "CD POWER OFF" appears.

To set CD power on

Repeat the procedure above and "CD POWER ON" appears.

Notes

- When "CD POWER OFF" is selected, disc access time is increased.
- You cannot change the setting in Power Saving Mode (page 24).

Listening to the radio

You can listen to a radio station either by selecting a preset station, or by manually tuning in the station.

Listening to a preset station

— Preset Tuning

Preset radio stations in the tuner's memory first (see "Presetting radio stations" on page 14).

- 1 Press TUNER BAND (or FUNCTION repeatedly) to switch the function to TUNER.
- 2 Press TUNER BAND repeatedly to select "FM" or "AM".
- 3 Press TUNING MODE repeatedly until "PRESET" appears in the display.
- 4 Press + or – (or turn – TUNING + on the unit) repeatedly to select the desired preset station.

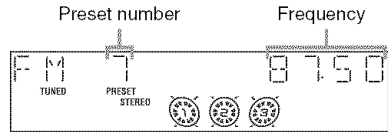

Listening to non-preset radio station

— Manual Tuning

- 1** Press TUNER BAND (or FUNCTION repeatedly) to switch the function to TUNER.
- 2** Press TUNER BAND repeatedly to select “FM” or “AM”.
- 3** Press TUNING MODE repeatedly until “AUTO” and “PRESET” disappear from the display.
- 4** Press + or – (or turn – TUNING + on the unit) repeatedly to tune in the desired station.

Note

When switching to CD function from tuner, a longer time may be required to access the disc. In this case, set “CD POWER ON” by CD power manage function (page 15).

Tips

- To improve broadcast reception, adjust the supplied antennas, or connect a commercially available external antenna.
- When an FM stereo program has static noise, press FM MODE repeatedly until “MONO” appears. There will be no stereo effect, but the reception will improve.
- Press TUNING MODE repeatedly until “AUTO” appears in step 3 above, then press + or – (or turn – TUNING + on the unit). The frequency indication changes and scanning stops when the system tunes in a station (Automatic Tuning).
- To record the radio programs, use manual recording (page 18).

Using the Radio Data System (RDS)

(European model only)

What is the Radio Data System?

Radio Data System (RDS) is a broadcasting service that allows radio stations to send additional information along with the regular program signal. RDS is available only on FM stations.*

Note

RDS may not work properly if the station you are tuned in is not transmitting the RDS signal properly or if the signal is weak.

* Not all FM stations provide RDS service, nor do they provide the same types of services. If you are not familiar with the RDS system, check with your local radio stations for details on RDS services in your area.

Receiving RDS broadcasts

Simply select a station from the FM band.

When you tune in a station that provides RDS services, the station name appears in the display.

To check the RDS information

Each time you press DISPLAY, the display changes cyclically as follows:

Station name¹⁾ → Preset number²⁾ and frequency → Clock display (for eight seconds) → Effect status

¹⁾If the RDS broadcast is not properly received, the station name may not appear in the display.

²⁾Preset number is displayed only if you preset radio stations (page 14).

Tape – Play

Loading a tape

Use buttons on the unit for the operation.

- 1** Press **TAPE A/B** repeatedly to select deck A or B.
- 2** Press **PUSH ▲**.
- 3** Load a recorded/recordable tape in deck A or B with the side you want to play/record facing forward.

With the side you want to play/record facing forward.

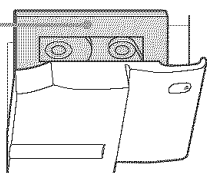

Playing a tape

You can use TYPE I (normal) tape.

- 1** **Load a tape.**
To play both decks in succession, press **PLAY MODE** repeatedly until “RELAY” (Relay Play)* appears in the display.
- 2** Press **TAPE** (or **FUNCTION** repeatedly) to switch the function to **TAPE**.
- 3** Press **▶**.

The tape starts playing.

* After the playback of the front side of deck A, deck B plays the front side, then stops.

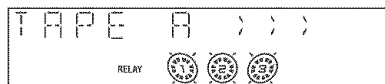

Other operations

To	Do this
Stop play	Press ■ .
Pause	Press ⏸ . Press again to resume play.
Fast-forward or rewind	Press ⏩ or ⏮ .
Remove a tape	Press PUSH ▲ on the unit in stop mode.

Searching for the beginning of the current or the next track (AMS)*

To go forward

Press **▶▶▶** (or turn **⏩⏩⏩** on the unit clockwise) during playback.

“TAPE A (or TAPE B) >>> +1” appears.

To go back

Press **⏮⏮⏮** (or turn **⏩⏩⏩** on the unit counterclockwise) during playback.

“TAPE A (or TAPE B) <<< -1” appears.

* AMS (Automatic Music Sensor)

Notes

- The AMS function may not operate correctly under the following circumstances:
 - When the unrecorded space between songs is less than 4 seconds long.
 - When the system is placed near a television.
- Do not eject the tape during playback or recording, as this may cause irreparable damage to the tape and cassette holder.

Tape – Recording

Recording your favorite CD tracks on a tape

— CD-TAPE Synchro Recording

You can record a whole CD on a tape. You can use TYPE I (normal) tape. The recording level is adjusted automatically. Use buttons on the unit for the operation.

- 1 Load a recordable tape into deck B, then press TAPE A/B repeatedly to select deck B.**
- 2 Press CD and load a disc you want to record.**

If you have already loaded the disc, press DISC SKIP/EX-CHANGE to select the disc.

When you want to record an album from an MP3 disc, be sure to press PLAY MODE repeatedly to select ALBM, then press ALBUM + or – repeatedly to select the desired album before proceeding.
- 3 Press CD SYNC.**

Deck B stands by for recording. “REC” flashes.
- 4 Press REC PAUSE/START.**

Recording starts. When the recording is completed, the CD player and the tape deck stop automatically.

To stop recording

Press ■.

To record a disc by specifying track order

You can record only your favorite CD tracks using Program Play. Between steps 2 and 3, perform steps 2 to 6 of “Creating your own program” (page 13).

Recording on a tape manually

— Manual Recording

You can record just the portions you like from a CD, tape or radio program on a tape. You can also record from connected components (see “Hooking up optional components” on page 27). Use buttons on the unit for the operation.

- 1 Load a recordable tape into deck B, then press TAPE A/B repeatedly to select deck B.**
- 2 Press one of the following buttons to select the desired source to record.**
 - CD: To record from this system’s CD player.
 - TAPE A/B: To record from this system’s tape deck A.
 - TUNER/BAND: To record from this system’s tuner.
 - AUDIO IN: To record from the optional component connected to the AUDIO IN jack.
- 3 Press REC PAUSE/START.**

Deck B stands by for recording. “REC” flashes.
- 4 Press REC PAUSE/START, then start playing the desired source to record.**

Recording starts.

To stop recording

Press ■.

Notes

- You cannot listen to other sources while recording.
- Recording stops if you change the function to another one.

Tip

For recording from the tuner:
If noise is heard while recording from the tuner, move the respective antenna to reduce the noise.

Sound Adjustment

Adjusting the sound

You can reinforce the bass and create a more powerful sound.

Press GROOVE on the unit.

Each time you press the button, the display changes cyclically as follows:

GROOVE ON* → GROOVE OFF

* The volume switches to power mode, the equalizer curve changes, and "GROOVE" lights up.

Using the sub woofer

(MHC-GX555/RG575S/RG475S only)

You can use the sound of the sub woofer to suit the sound source.

Press SUBWOOFER ON/OFF on the unit.

Each time you press the button, the display changes cyclically as follows:

SUB ON* → SUB OFF

* The SUBWOOFER ON/OFF indicator lights up.

Note

Make sure to turn off the SUBWOOFER ON/OFF indicator when the sub woofer is not connected to the system.

Tip

You can use VOLUME +/- (or VOLUME control on the unit) to adjust the volume of the sub woofer linked to the front speakers.

Selecting the sound effect

Selecting the effect from the music menu

Press EQ (or PRESET EQ on the unit) repeatedly to select the preset you desire.

The preset name appears in the display. See the chart "Sound effect options".

To cancel the sound effect

Press EFFECT ON/OFF on the unit.

Sound effect options

"SURR" appears if you select an effect with surround effects.

EQ

ROCK
POP
JAZZ
DANCE
SOUL
ORIENTAL
REGGAE
SALSA
SAMBA

Adjusting the graphic equalizer and storing

You can adjust the sound by raising or lowering the levels of specific frequency ranges, then store up to three personal files (P FILE) in the memory.

Before operation, first select the audio emphasis you want for your basic sound.

Use buttons on the unit for the operation.

- 1 Press EQ BAND repeatedly to select a frequency band, then turn – EQ + to adjust the level.**

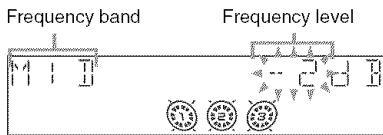

- 2 Press and hold P FILE.**
A personal file number appears.
- 3 Press P FILE repeatedly to select P FILE 1 – 3 you want to store the equalizer setting.**
- 4 Press ENTER.**

“COMPLETE” appears.

This setting is automatically stored as the personal file you selected in step 3.

Other operations

To	Press
Call up a personal file	P FILE repeatedly to select the desired personal file number.
Cancel a personal file	EFFECT ON/OFF repeatedly until “EFFECT OFF” appears.

Selecting the surround effect

Press SURROUND on the unit.

Each time you press the button, the display changes as follows:

SURROUND ON (SURR)



SURROUND OFF (off)

Singing along: Karaoke

(Latin American model only)

You can sing along by connecting an optional microphone. Use buttons on the unit for the operation.

Enjoying karaoke

- 1 Turn **MIC LEVEL** to **MIN** to turn down the microphone control level.
- 2 Connect an optional microphone to **MIC jack**.
- 3 **(Mexican model only)**
Press **MULTIPLEX** repeatedly to obtain the karaoke effect you desire.
Each time you press the button, the display changes cyclically as follows:
MPX L → MPX R → MPX OFF
To sing karaoke of multiplex CD, select “MPX L” or “MPX R”.
- 4 Start playing the music.
- 5 Adjust the microphone volume by turning **MIC LEVEL**.

After you have finished

Turn **MIC LEVEL** to **MIN** and disconnect the microphone from **MIC jack**.

Other operations

To	Do this
Cancel karaoke mode*	Turn MIC LEVEL to MIN and disconnect the microphone from MIC jack , then press MULTIPLEX repeatedly until “  <p>* Mexican model only</p>

Mixing and recording sounds

You can “mix” sounds by playing one of the components and singing or speaking into a microphone (not supplied).

The mixed sound can be recorded on a tape. Use buttons on the unit for the operation.

- 1 **Prepare the source you want to mix. Then, load a recordable tape in deck B and press TAPE A/B repeatedly to select deck B.**
- 2 **Press the function button of the source you want to record (e.g., CD).**
When you want to record from **TAPE A**, press **TAPE A/B** repeatedly until **TAPE A** is selected.
- 3 **Press REC PAUSE/START.**
Deck B stands by for recording. “REC” flashes.
- 4 **Press REC PAUSE/START, and then start singing, speaking or playing the desired source.**
Recording starts.

To stop recording

Press .

Note

Microphone does not function while the tape deck is performing the AMS operation (page 17).

Tips

- If acoustic feedback (howling) occurs, move the microphone away from the speakers or change the direction of the microphone.
- If you want to record your voice through the microphone only, you can do so by selecting the **CD** function and not playing a disc.
- When high level sound signals are input, the system automatically adjusts the recording level to prevent distortion of the recorded sound signal (Auto Level Control function).

Timer

Falling asleep to music

— Sleep Timer

You can set the system to turn off after a certain time, so that you can fall asleep to music.

Press SLEEP.

Each time you press the button, the minute display (the turn-off time) changes cyclically as follows:

AUTO* → 90MIN → 80MIN → 70MIN
→ ... → 10MIN → OFF

* The system automatically turns off in 100 minutes or after the current disc or tape finishes playing.

Other operations

To	Press
Check the remaining time*	SLEEP once.
Change the time to turn off	SLEEP repeatedly to select the time you want.
Cancel the Sleep Timer function	SLEEP repeatedly until "SLEEP OFF" appears.

* You cannot check the remaining time if you select "AUTO".

Note

Do not set to "AUTO" during Synchro Recording on a tape.

Tip

You can use the Sleep Timer, even if you have not set the clock.

Waking up to music

— Play Timer

You can wake up to music at a preset time. Make sure you have set the clock (see "Setting the clock" on page 9).

Use buttons on the remote for the operation.

1 Prepare the sound source you want to play.

- CD: Load a disc. To start from a specific track, make a program (see "Creating your own program" on page 13).
- Tape: Load a tape with the side you want to play facing forward.
- Tuner: Tune in the preset radio station (see "Listening to the radio" on page 15).

2 Press VOLUME +/- to adjust the volume.

3 Press CLOCK/TIMER SET.

4 Press ◀◀ or ▶▶ repeatedly to select "PLAY SET", then press ENTER.

"ON" appears and the hour indication flashes.

5 Set the time to start playing.

Press ◀◀ or ▶▶ repeatedly to set the hour, then press ENTER.

The minute indication flashes.

Press ◀◀ or ▶▶ repeatedly to set the minute, then press ENTER.

6 Set the time to stop playing following the same procedure as step 5.

7 Press ◀◀ or ▶▶ repeatedly until the desired sound source appears.

Each time you press the button, the display changes cyclically as follows:

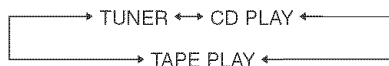

8 Press ENTER.

The type of timer (“PLAY TIMER”), the start time, the stop time, and the sound source appear in turn, before the original display returns.

9 Press I/⏻ to turn off the system.

Other operations

To	Do this
Activate the timer/ Check the setting	1 Press CLOCK/TIMER SELECT. 2 Press ◀◀ or ▶▶ repeatedly until “PLAY SELECT” appears, then press ENTER.
Change the setting	Start over from step 1.
Cancel the timer	1 Press CLOCK/TIMER SELECT. 2 Press ◀◀ or ▶▶ repeatedly until “TIMER OFF” appears, then press ENTER.

Notes

- You cannot activate the Play Timer and the Rec Timer at the same time.
- If you use the Play Timer and the Sleep Timer at the same time, the Sleep Timer has priority.
- If the system is on at the preset time, the Play Timer will not be activated.
- The Play Timer setting remains as long as the setting is not canceled manually.

Tip

The system turns on 15 seconds before the preset time.

Timer recording radio programs

— Rec Timer

You can record a preset radio station from a specified time.

To timer record, you must first preset the radio station (see “Presetting radio stations” on page 14) and set the clock (see “Setting the clock” on page 9).

Use buttons on the remote for the operation.

- 1 Tune in the preset radio station (see “Listening to a preset station” on page 15).**
- 2 Press CLOCK/TIMER SET.**
- 3 Press ◀◀ or ▶▶ repeatedly to select “REC SET”, then press ENTER.**
“ON” appears and the hour indication flashes.
- 4 Set the time to start recording.**
Press ◀◀ or ▶▶ repeatedly to set the hour, then press ENTER.
The minute indication flashes.
Press ◀◀ or ▶▶ repeatedly to set the minute, then press ENTER.
- 5 Set the time to stop recording following the same procedure as step 4.**
The type of timer (“REC TIMER”), the start time, the stop time, and the preset radio station to be recorded (e.g., “TUNER FM 5”) appear in turn, before the original display returns.
- 6 Load a recordable tape into deck B.**
- 7 Press I/⏻ to turn off the system.**

Other operations

To	Do this
Activate the timer/ Check the setting	<ol style="list-style-type: none">1 Press CLOCK/TIMER SELECT.2 Press ◀◀ or ▶▶ repeatedly until "REC SELECT" appears, then press ENTER.
Change the setting	Start over from step 1.
Cancel the timer	<ol style="list-style-type: none">1 Press CLOCK/TIMER SELECT.2 Press ◀◀ or ▶▶ repeatedly until "TIMER OFF" appears, then press ENTER.

Notes

- You cannot activate the Play Timer and the Rec Timer at the same time.
- If you use the Rec Timer, the Play Timer and the Sleep Timer at the same time, the Sleep Timer has priority.
- If the system is on at the preset time, the Rec Timer will not be activated.
- The volume is reduced to minimum during recording.
- The Rec Timer is canceled automatically after the Rec Timer has been activated.

Display

Turning off the display

— Power Saving Mode

The demonstration display (display window and buttons lighting and flashing even when the system power is off) and the clock display can be turned off to minimize the amount of power consumed during standby (Power Saving Mode).

Press DISPLAY repeatedly while the system is off until the demonstration display or the clock display disappears.

To cancel Power Saving Mode

Press DISPLAY while the system is off. Each time you press the button, the display switches cyclically as follows:

Demonstration display → Clock display* → No display (Power Saving Mode)

* The clock is displayed only if you set the clock.

Note

You cannot perform the following operations in Power Saving Mode.

- setting the clock
- changing the AM tuning interval (except for European, Russian and Saudi Arabian models)
- turning on the system by pressing the function buttons (e.g., CD)
- changing the CD power manage function

Tips

- The timer continues to operate in Power Saving Mode.
- I/Ⓞ indicator lights up even in Power Saving Mode.

Viewing information about the disc in the display

You can check the playing time and remaining time of the current track or that of the disc. When a disc with MP3 audio tracks is loaded, you can also check the information recorded on disc, such as the titles.

Checking the remaining time and titles

Press DISPLAY during Normal Play.

Each time you press the button, the display changes cyclically as follows:

Current track number and elapsed playing time → Current track number and remaining time¹⁾ → Remaining time of the disc²⁾ → Track title and artist name (disc with MP3 audio tracks³⁾ only) → Album name (disc with MP3 audio tracks³⁾ only) → Clock display (for eight seconds) → Effect status

¹⁾ “_ _ _ _” appears when playing back MP3 audio tracks.

²⁾ “_ _ _ _” appears in ALL DISCS, SHUFFLE or Program Play mode or when playing back MP3 audio tracks.

³⁾ When you play back a track with an ID3 tag ver. 1 or ver. 2, the ID3 tag information appears. The ID3 tag displays the track title, album name and artist name information.

Checking the total playing time and titles

Press DISPLAY in stop mode.

Each time you press the button, the display changes cyclically as follows:

■ Normal Play mode

TOC display¹⁾ or total album number of the disc²⁾ or total track number of the current album²⁾ → Album name²⁾ or volume label²⁾ → Clock display (for eight seconds) → Effect status

¹⁾ TOC = Table of Contents; displays current disc number, total number of tracks on the disc, and total playing time of the disc.

²⁾ For discs with MP3 audio tracks, album names or volume label may not be displayed depending on the play mode.

■ Program Play mode

The last track number of the program and the total playing time → Total track number of the program (for five seconds) → Volume label* → Clock display (for eight seconds) → Effect status

* For discs with MP3 audio tracks

Notes

- The total playing time is not displayed for a disc with MP3 audio tracks.
- ID3 tag applies to version 1 and version 2.
- If the MP3 audio track you play back has an ID3 tag, the ID3 tag information is displayed.
- In the following cases, elapsed playing time and remaining time of the track may not be displayed accurately.
 - when an MP3 audio track of VBR (variable bit rate) is played.
 - when fast forward or fast reverse is performed.
- For Russian model, MP3 and ID3 tag information can be displayed in Russian characters. However, depending on the encoding/writing software or recording device, the characters may not be correctly displayed.

Changing the Power illuminator

Press **ILLUMINATION** on the unit.

Each time you press the button, the power illuminator changes cyclically as follows:

MHC-GX555/RG575S/RG475S/RG470

PATTERN 1 → PATTERN 2 → PATTERN 3
→ ILLUM OFF

MHC-GX355/RG255/RG270/RG170

ILLUM ON ↔ ILLUM OFF

Viewing the tuner information in the display

Press **DISPLAY** while listening to the radio.

Each time you press the button, the display changes cyclically as follows:

Station name¹⁾ → Preset number²⁾ and
frequency → Clock display (for eight seconds)
→ Effect status

¹⁾ European model only

²⁾ Preset number is displayed only if you preset radio stations (page 14).

Optional Components

Hooking up optional components

To enhance your system, you can connect optional components. Refer to the operating instructions provided with each component. A North American model is used for illustration purpose.

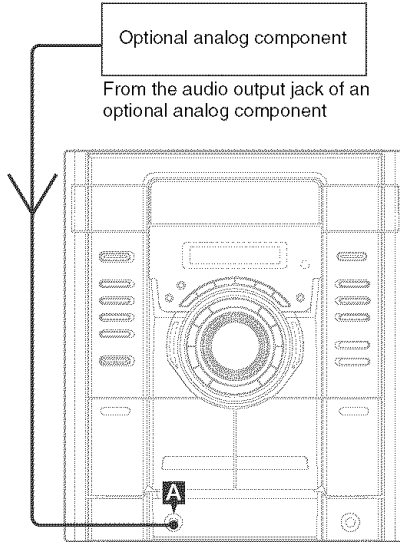

A AUDIO IN jack

Use audio cord (not supplied) to connect an optional analog component (Portable Audio Player, etc.) to this jack. You can then record or listen to the sound from the component through this system.

Note

Before connecting or disconnecting the audio cord (not supplied), press **VOLUME** – repeatedly (or turn the **VOLUME** control on the unit counterclockwise) to turn down the volume.

Listening to audio from a connected component

- 1 Connect the audio cord (not supplied). See “Hooking up optional components”.
- 2 Press **FUNCTION** repeatedly (or **AUDIO IN** on the unit) until “**AUDIO IN**” appears.
- 3 Start playing the connected component.

Recording audio from connected component

- 1 Connect the audio cord (not supplied).
- 2 Start recording manually. See “Recording on a tape manually” on page 18.

Notes

- If the connected component has the AVLS (Automatic Volume Limiter System) function, be sure to turn off the function when using the **AUDIO IN**. Otherwise, you will have to turn up the volume of the speaker, and that may cause distortion.
- If the connected component has the **BASS BOOST** or **MEGA BASS** function, be sure to turn off the function when using the **AUDIO IN**. Otherwise, the sound from the speaker may be distorted.

Troubleshooting

Problems and remedies

Should you encounter a problem with your system, do the following:

- 1 Make sure the power cord and speaker cords are correctly and firmly connected.
- 2 Find your problem in the troubleshooting checklist below and take the indicated corrective action.

If the problem persists after doing all of the above, consult your nearest Sony dealer.

When the I/⏻ indicator flashes

Immediately unplug the power cord and check the following items.

- If your system has a voltage selector, is the voltage selector set to the correct voltage? Check the voltage for your region, then make sure the voltage selector is set correctly.
- Are the + and – speaker cords short-circuited?
- Are you using only the prescribed speakers?
- Is anything blocking the ventilation holes on the rear of the system?

Check all the above items and fix any problems found. After I/⏻ indicator stops flashing, reconnect the power cord and turn on the system. If the indicator still flashes, or if the cause of the problem cannot be found even after checking all the above items, consult your nearest Sony dealer.

General

The display starts flashing as soon as you plug in the power cord even though you have not turned on the system (see step 6 of “Hooking up the system” (page 6)).

- Press DISPLAY twice while the system is off. The demonstration disappears.

“--:--” appears in the display.

- A power interruption has occurred. Set the clock (page 9) and timer settings (pages 22 and 23) again.

The clock setting/radio presetting/timer is canceled.

- Redo the following:
 - “Setting the clock” (page 9)
 - “Presetting radio stations” (page 14)
 - “Falling asleep to music” and “Waking up to music” (page 22)
 - “Timer recording radio programs” (page 23)

There is no sound.

- Press VOLUME +/- or turn VOLUME control on the unit clockwise.
- Make sure the headphones are not connected.
- Check the speaker connections (page 6).
- There is no audio output during the Rec Timer.

Sound comes from one channel, or unbalanced left and right volume.

- Place the speakers as symmetrically as possible.
- Connect the supplied speakers.

Sound lacks bass.

- Check that the speaker’s + and – jacks are connected correctly.

There is severe hum or noise.

- Move the system away from the source of noise.
- Connect the system to a different wall outlet.
- Install a noise filter (commercially available) to the power cord.

The timer cannot be set.

- Set the clock again (page 9).

The timer does not function.

- Check the timer setting and set the correct time (pages 23 and 24).
- Cancel the Sleep Timer function (page 22).

The remote does not function.

- Remove the obstacle.
- Move the remote closer to the system.
- Point the remote at the system's sensor.
- Replace the batteries (R6/size AA).
- Locate the system away from the fluorescent light.

There is acoustic feedback.

- Reduce the volume.
- For Latin American model, move the microphone away from the speakers or change the direction of the microphone.

The color irregularity on a TV screen persists.

- Turn off the TV set once, then turn it on after 15 to 30 minutes. If the color irregularity still persists, place the speakers farther away from the TV set.

CD/MP3 player



The disc tray does not open and "LOCKED" appears.

- Contact your Sony dealer or local authorized Sony service facility.

The disc tray does not close.

- Place the disc correctly.
- Always close the tray by pressing  on the unit. Trying to press the tray closed with your fingers may cause problems with the player.

The disc does not eject.

- You cannot eject the disc during CD Synchro Recording. Press  to cancel the CD Synchro Recording, then press  on the unit to eject the disc.
- Consult your nearest Sony dealer.

There is no picture (Mexican model only).

- Check that the system is connected securely.
- Make sure you connect the system to the video input jack of your TV (page 7).
- Make sure you turn on the TV and operate the TV correctly.
- Make sure you select the video input on the TV so that you can view the pictures from this system.
- This system conforms to the NTSC color system. Make sure your TV (color) system is NTSC.
- Press CD (or FUNCTION repeatedly) to switch the function to CD.

Play does not start.

- Open the disc tray and check whether a disc is loaded.
- Wipe the disc clean (page 33).
- Replace the disc.
- Place the disc that this system can play (page 4).
- Place the disc correctly.
- Place the disc in the tray with the label side up.
- Remove the disc and wipe away the moisture on the disc, then leave the system turned on for a few hours until the moisture evaporates.
- Press  to start play.

Disc access takes a long time.

- Set "CD POWER ON" by CD power manage function (page 15).

The sound skips.

- Wipe the disc clean (page 33).
- Replace the disc.
- Try moving the system to a place without vibration (e.g., on top of a stable stand).
- Try moving the speakers away from the system, or placing them on separate stands. When you listen to a track with bass sounds at high volume, the speaker vibration may cause the sound to skip.

Play does not start from the first track.

- Press PLAY MODE repeatedly until both "PGM" and "SHUF" disappear to return to Normal Play.

MP3 audio track cannot be played back.

- Recording was not performed according to the ISO9660 Level 1 or Level 2 format or Joliet in the expansion format.
- The MP3 audio track does not have the extension ".MP3".
- The data is not stored in MP3 format.
- Discs containing files other than MPEG 1 Audio Layer-3 files cannot be played.

MP3 audio tracks take longer to play back than others.

- After the system reads all tracks on the discs, playback may take more time than usual if:
 - the number of albums or tracks on the disc is very large.
 - the album and track organization structure is very complex.

The album name, track title and ID3 tag information do not appear correctly.

- Use a disc that conforms with ISO9660 Level 1, Level 2 or Joliet in the expansion format.
 - The disc ID3 tag is not ver. 1 nor ver. 2.
 - Only up to 30 characters of ID3 tags are displayed.
 - The characters that can be displayed by this system are as follows:
 - Upper cases (A to Z)
 - Numbers (0 to 9)
 - Symbols (' < > * + , - / @ [\] _)
- Other characters may not be displayed correctly.

Tuner

Severe hum or noise/stations cannot be received. ("TUNED" or "STEREO" flashes in the display.)

- Set the proper band and frequency (page 14).
- Connect the antenna properly (page 7).
- Find a place and an orientation that provide good reception, then set up the antenna again. If you cannot obtain good reception, we recommend you connect a commercially available external antenna.
- The supplied FM lead antenna receives signals along its entire length, so make sure you extend it fully.
- Locate the antennas as far away from the speaker cords as possible.
- Try turning off surrounding electrical equipment.
- Set "CD POWER OFF" by CD power manage function (page 15).

A stereo FM program cannot be received in stereo.

- Press FM MODE repeatedly until "STEREO" appears.

Tape deck

The tape does not record or play, or there is a decrease in sound level.

- The heads are dirty. Clean them (page 33).
- The record/playback heads are magnetized. Demagnetize them (page 33).

The tape does not erase completely.

- The record/playback heads are magnetized. Demagnetize them (page 33).

There is excessive wow or flutter, or the sound drops out.

- The capstans or pinch rollers are dirty. Clean them (page 33).

Noise increases or the high frequencies are erased.

- The record/playback heads are magnetized. Demagnetize them (page 33).

The tape does not record.

- No cassette is loaded. Load a cassette.
- The tab has been removed from the cassette. Cover the broken tab with adhesive tape (page 33).
- The tape has wound to the end.

If the system still does not operate properly after performing the above measures, reset the system as follows:

Use buttons on the unit for the operation.

- 1 Disconnect the power cord.
- 2 Reconnect the power cord.
- 3 Press I/⏻ to turn on the system.
- 4 Press ■, ILLUMINATION and DISC 1 at the same time.

The system is reset to the factory settings. You should set the settings you made, such as the preset stations, clock, and timer.

Note

You cannot reset the system to the factory settings in Power Saving Mode (page 24).

Messages

One of the following messages may appear or flash in the display during operation.

CD/MP3

NO DISC

There is no disc in the player or you have loaded a disc that cannot be played on this system (such as DVD, VCD, or CD-ROM without MP3 audio tracks, etc.).

NO STEP

All of the programmed tracks have been erased.

OVER

You have reached the end of the disc while pressing **▶▶** during playback or pause.

PUSH STOP

You pressed **PLAY MODE** during playback.

READING

The system is reading information of the disc. Some buttons are not available.

STEP FULL

You tried to program 26 or more tracks (steps).

Tuner

COMPLETE

The preset operation ended normally.

Tape

NO TAB

You cannot record the tape because the tab has been removed from the cassette.

NO TAPE

There is no tape in the tape deck.

Timer

PUSH SELECT

You tried to set the clock or timer during timer operation.

SET CLOCK

You tried to select the timer when the clock is not set.

SET TIMER

You tried to select the timer when the Play Timer or Rec Timer are not set.

TIME NG

The Play Timer or Rec Timer start and end times are set to the same time.

Other

NOT IN USE

You pressed an invalid button.

Additional Information

Precautions

On operating voltage

Before operating the system, check that the operating voltage of your system is identical with the voltage of your local power supply.

On safety

- The unit is not disconnected from the AC power source (mains) as long as it is connected to the wall outlet, even if the unit itself has been turned off.
- Unplug the system from the wall outlet (mains) if it is not to be used for an extended period of time. To disconnect the power cord (mains lead), pull it out by the plug. Never pull the cord itself.
- Should any solid object or liquid fall into the system, unplug the system and have it checked by qualified personnel before operating it any further.
- AC power cord must be changed only at the qualified service shop.

On placement

- Do not place the system in an inclined position.
- Do not place the system in locations where it is:
 - Extremely hot or cold
 - Dusty or dirty
 - Very humid
 - Subject to vibrations
 - Subject to direct sunlight.
- Use caution when placing the unit or speakers on surfaces that have been specially treated (with wax, oil, polish, etc.) as staining or discoloration of the surface may result.

On heat buildup

- Although the system heats up during operation, this is not a malfunction.
- Place the system in a location with adequate ventilation to prevent heat buildup in the system.
- If you continuously use this system at a high volume, the cabinet temperature of the top, side and bottom rises considerably. To avoid burning yourself, do not touch the cabinet.
- To prevent a malfunction, do not cover the ventilation hole for the cooling fan.

On the speaker system

(Except for Mexican model)

This speaker system is not magnetically shielded and the picture on TV sets may become magnetically distorted. In such a case, turn off the power of the TV set once, and after 15 to 30 minutes turn it on again.

If there seems to be no improvement, locate the speaker system further away from the TV set.

(Mexican model only)

In case color irregularity is observed on nearby a TV screen

With the magnetically shielded type of front speaker system, the front speakers can be installed near a TV set. However, color irregularity may still be observed on the TV screen depending on the type of your TV set.

If color irregularity is observed...

Turn off the TV set once, then turn it on after 15 to 30 minutes. Make sure you place the right speaker on the right side and the left speaker on the left side of the unit.

If color irregularity is observed again...

Place the speakers farther away from the TV set.

IMPORTANT NOTICE

Caution: This system is capable of holding a still video image or on-screen display image on your television screen indefinitely. If you leave the still video image or on-screen display image displayed on your TV for an extended period of time you risk permanent damage to your television screen. Projection televisions are especially susceptible to this.

On operation

- If the system is brought directly from a cold to a warm location, or is placed in a very damp room, moisture may condense on the lens inside the CD player. Should this occur, the system will not operate properly. Remove the disc and leave the system turned on for about an hour until the moisture evaporates.
- When you move the system, take out any disc.

If you have any questions or problems concerning your system, please consult your nearest Sony dealer.

Notes on discs

- Before playing, clean the disc with a cleaning cloth. Wipe the disc from the center out.
- Do not use solvents such as benzine, thinner, commercially available cleaners or anti-static spray intended for vinyl LPs.
- Do not expose the disc to direct sunlight or heat sources such as hot air ducts, nor leave it in a car parked in direct sunlight.
- When using discs that have glue or similar tacky substance on the label side of the disc or that used a special ink when the label was printed, there is a chance that the disc or label may become attached to parts inside this unit. When this occurs, it may not be possible to remove the disc, and may also cause this unit to malfunction. Be sure to check that the label side of the disc is not sticky before using. The following types of disc should not be used:
 - Rental or used discs with attached seals where the glue extends beyond the seal. The perimeter of the seal on the disc is tacky.
 - Discs that have labels printed using a special ink that feels tacky when touched.
- Discs with non-standard shapes (e.g., heart, square, star) cannot be played on this unit. Attempting to do so may damage the unit. Do not use such discs.

Cleaning the cabinet

Clean the cabinet, panel and controls with a soft cloth slightly moistened with mild detergent solution. Do not use any type of abrasive pad, scouring powder or solvent such as thinner, benzine or alcohol.

To save a tape permanently

To prevent a tape from being accidentally recorded over, break off the cassette tab from side A or B as illustrated.

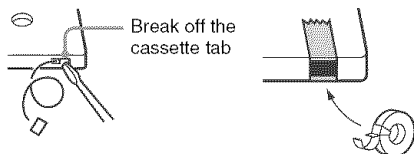

If you later want to reuse the tape for recording, cover the broken tab with adhesive tape.

Before placing a cassette in the tape deck

Take up any slack in the tape. Otherwise, the tape may get entangled in the parts of the tape deck and become damaged.

When using a tape longer than 90 minutes

The tape is very elastic. Do not change the tape operations such as play, stop, and fast-winding frequently. The tape may get entangled in the tape deck.

Cleaning the tape heads

Clean the tape heads after every 10 hours of use. Be sure to clean the tape heads before you start an important recording or after playing an old tape. Use a separately sold dry-type or wet-type cleaning cassette. For details, refer to the instructions of the cleaning cassette.

Demagnetizing the tape heads

Demagnetize the tape heads and the metal parts that have contact with the tape after every 20 to 30 hours of use with a separately sold demagnetizing cassette. For details, refer to the instructions of the demagnetizing cassette.

Specifications

Amplifier section

AUDIO POWER SPECIFICATIONS (MHC-GX555/GX355 USA model only)

MHC-GX555

POWER OUTPUT AND TOTAL HARMONIC DISTORTION:

With 6 ohm loads, both channels driven, from 120 – 10,000 Hz: rated 145 watts per channel minimum RMS power, with no more than 10% total harmonic distortion from 250 milliwatts to rated output.

MHC-GX355

POWER OUTPUT AND TOTAL HARMONIC DISTORTION:

With 6 ohm loads, both channels driven, from 120 – 10,000 Hz: rated 150 watts per channel minimum RMS power, with no more than 10% total harmonic distortion from 250 milliwatts to rated output.

North American model:

MHC-GX555

Front speaker

Continuous RMS power output (reference):

145 + 145 watts (6 ohms at
1 kHz, 10% THD)

Total harmonic distortion less than 0.07% (6 ohms at
1 kHz, 80 W)

Sub woofer

Continuous RMS power output (reference):

170 watts (6 ohms at
80 Hz, 10% THD)

Total harmonic distortion less than 0.07% (6 ohms at
80 Hz, 90 W)

MHC-GX355

Continuous RMS power output (reference):

150 + 150 watts (6 ohms at
1 kHz, 10% THD)

Total harmonic distortion less than 0.07% (6 ohms at
1 kHz, 80 W)

Canadian model:

MHC-GX255

Continuous RMS power output (reference):

65 + 65 watts (6 ohms at
1 kHz, 10% THD)

Total harmonic distortion less than 0.07% (6 ohms at
1 kHz, 40 W)

European and Russian models:

MHC-RG475S

Front speaker

DIN power output (rated): 110 + 110 watts (6 ohms at
1 kHz, DIN)

Continuous RMS power output (reference):

140 + 140 watts (6 ohms at
1 kHz, 10% THD)

Music power output (reference):

280 + 280 watts (6 ohms at
1 kHz, 10% THD)

Sub woofer

DIN power output (rated): 130 watts (6 ohms at
80 Hz, DIN)

Continuous RMS power output (reference):

160 watts (6 ohms at
80 Hz, 10% THD)

Music power output (reference):

320 watts (6 ohms at
80 Hz, 10% THD)

MHC-RG470

DIN power output (rated): 110 + 110 watts (6 ohms at
1 kHz, DIN)

Continuous RMS power output (reference):

140 + 140 watts (6 ohms at
1 kHz, 10% THD)

Music power output (reference):

280 + 280 watts (6 ohms at
1 kHz, 10% THD)

MHC-RG270

DIN power output (rated): 80 + 80 watts (6 ohms at
1 kHz, DIN)

Continuous RMS power output (reference):

100 + 100 watts (6 ohms at
1 kHz, 10% THD)

Music power output (reference):

200 + 200 watts (6 ohms at
1 kHz, 10% THD)

MHC-RG170

DIN power output (rated): 20 + 20 watts (6 ohms at 1 kHz, DIN)
Continuous RMS power output (reference):
25 + 25 watts (6 ohms at 1 kHz, 10% THD)
Music power output (reference):
50 + 50 watts (6 ohms at 1 kHz, 10% THD)

Other models:

MHC-RG575S

The following measured at AC 120, 127, 220, 240 V 50/60 Hz
Front speaker
DIN power output (rated): 100 + 100 watts (6 ohms at 1 kHz, DIN)
Continuous RMS power output (reference):
125 + 125 watts (6 ohms at 1 kHz, 10% THD)
Sub woofer
DIN power output (rated): 120 watts (6 ohms at 80 Hz, DIN)
Continuous RMS power output (reference):
150 watts (6 ohms at 80 Hz, 10% THD)

MHC-RG475S

Front speaker
The following measured at AC 120, 127, 220, 240 V 50/60 Hz
DIN power output (rated): 100 + 100 watts (6 ohms at 1 kHz, DIN)
Continuous RMS power output (reference):
120 + 120 watts (6 ohms at 1 kHz, 10% THD)
Sub woofer
DIN power output (rated): 120 watts (6 ohms at 80 Hz, DIN)
Continuous RMS power output (reference):
150 watts (6 ohms at 80 Hz, 10% THD)

MHC-RG470

The following measured at AC 120, 127, 220, 240 V 50/60 Hz
DIN power output (rated): 130 + 130 watts (6 ohms at 1 kHz, DIN)
Continuous RMS power output (reference):
160 + 160 watts (6 ohms at 1 kHz, 10% THD)

MHC-RG270

The following measured at AC 120, 127, 220, 240 V 50/60 Hz
DIN power output (rated): 100 + 100 watts (6 ohms at 1 kHz, DIN)
Continuous RMS power output (reference):
125 + 125 watts (6 ohms at 1 kHz, 10% THD)

MHC-RG170

The following measured at AC 120, 127, 220, 240 V 50/60 Hz
DIN power output (rated): 50 + 50 watts (6 ohms at 1 kHz, DIN)
Continuous RMS power output (reference):
65 + 65 watts (6 ohms at 1 kHz, 10% THD)

Inputs

AUDIO IN (stereo mini jack):

voltage 250 mV,
impedance 47 kilohms

MIC (phone jack) (Latin American model only):

sensitivity 1 mV,
impedance 10 kilohms

Outputs

PHONES (stereo mini jack):

accepts headphones of
8 ohms or more
VIDEO OUT (phono jack) (Mexican model only):
max. output level 1Vp-p,
unbalanced, Sync
negative, load impedance
75 ohms

SPEAKER:

accepts impedance of 6 to
16 ohms

SUBWOOFER OUT (MHC-GX555/RG575S/

RG475S only):
accepts impedance of 6 to
16 ohms

CD player section

System Compact disc and digital audio system
Laser Diode Properties Emission duration: continuous
Laser Output*: Less than 44.6µW

* This output is the value measurement at a distance of 200mm from the objective lens surface on the Optical Pick-up Block with 7mm aperture.

Frequency response 2 Hz – 20 kHz (±0.5 dB)
Signal-to-noise ratio More than 90 dB
Dynamic range More than 90 dB

Tape deck section

Recording system	4-track 2-channel, stereo
Frequency response	50 – 13,000 Hz (± 3 dB), using Sony TYPE I cassettes
Wow and flutter	$\pm 0.15\%$ W. Peak (IEC) 0.1% W. RMS (NAB) $\pm 0.2\%$ W. Peak (DIN)

Tuner section

FM stereo, FM/AM superheterodyne tuner

FM tuner section

Tuning range	
North American model:	87.5 – 108.0 MHz (100 kHz step)
Other models:	87.5 – 108.0 MHz (50 kHz step)
Antenna	FM lead antenna
Antenna terminals	75 ohms unbalanced
Intermediate frequency	10.7 MHz
AM tuner section	
Tuning range	
Pan-American models:	530 – 1,710 kHz (with the tuning interval set at 10 kHz) 531 – 1,710 kHz (with the tuning interval set at 9 kHz)
European, Russian and Saudi Arabian models:	531 – 1,602 kHz (with the tuning interval set at 9 kHz)
Other models:	530 – 1,710 kHz (with the tuning interval set at 10 kHz) 531 – 1,602 kHz (with the tuning interval set at 9 kHz)
Antenna	AM loop antenna
Intermediate frequency	450 kHz

Speaker

North American model:

Front speaker SS-GX555 for MHC-GX555

Speaker system	3-way, 3-unit, bass-reflex type
Speaker units	
Woofer:	13 cm, cone type
Sub woofer:	13 cm, cone type
Tweeter:	5 cm, cone type
Nominal impedance	6 ohms
Dimensions (w/h/d)	Approx. 230 × 345 × 235 mm
Mass	Approx. 3.8 kg net per speaker

Sub woofer SS-WG555 for MHC-GX555

Speaker system	Bass-reflex type
Speaker units	
Woofer:	20 cm, cone type
Nominal impedance	6 ohms
Dimensions (w/h/d)	Approx. 265 × 325 × 330 mm
Mass	Approx. 5.5 kg

Front speaker SS-GX555 for MHC-GX355

Speaker system	3-way, 3-unit, bass-reflex type
Speaker units	
Woofer:	13 cm, cone type
Sub woofer:	13 cm, cone type
Tweeter:	5 cm, cone type
Nominal impedance	6 ohms
Dimensions (w/h/d)	Approx. 230 × 345 × 235 mm
Mass	Approx. 3.8 kg net per speaker

Canadian model:

Front speaker SS-GX255 for MHC-GX255

Speaker system	3-way, 3-unit, bass-reflex type
Speaker units	
Super Tweeter:	2 cm, dome type
Woofer:	13 cm, cone type
Tweeter:	5 cm, cone type
Nominal impedance	6 ohms
Dimensions (w/h/d)	Approx. 200 × 325 × 230 mm
Mass	Approx. 3.0 kg net per speaker

European and Russian models:**Front speaker SS-RG475 for MHC-RG475S**

Speaker system	3-way, 3-unit, bass-reflex type
Speaker units	
Woofer:	13 cm, cone type
Sub woofer:	13 cm, cone type
Tweeter:	5 cm, cone type
Nominal impedance	6 ohms
Dimensions (w/h/d)	Approx. 230 × 345 × 235 mm
Mass	Approx. 3.8 kg net per speaker

Sub woofer SS-WG475 for MHC-RG475S

Speaker system	Bass-reflex type
Speaker units	
Woofer:	20 cm, cone type
Nominal impedance	6 ohms
Dimensions (w/h/d)	Approx. 265 × 325 × 330 mm
Mass	Approx. 5.5 kg

Front speaker SS-RG575 for MHC-RG470

Speaker system	3-way, 4-unit, bass-reflex type
Speaker units	
Sub Woofer:	15 cm, cone type
Woofer:	15 cm, cone type
Tweeter:	5 cm × 2, cone type
Nominal impedance	6 ohms
Dimensions (w/h/d)	Approx. 245 × 380 × 290 mm
Mass	Approx. 5.5 kg net per speaker

Front speaker SS-RG475 for MHC-RG270

Speaker system	3-way, 3-unit, bass-reflex type
Speaker units	
Woofer:	13 cm, cone type
Sub woofer:	13 cm, cone type
Tweeter:	5 cm, cone type
Nominal impedance	6 ohms
Dimensions (w/h/d)	Approx. 230 × 345 × 235 mm
Mass	Approx. 3.8 kg net per speaker

Front speaker SS-RG170E for MHC-RG170

Speaker system	3-way, 3-unit, bass-reflex type
Speaker units	
Super Tweeter:	2 cm, dome type
Woofer:	13 cm, cone type
Tweeter:	5 cm, cone type
Nominal impedance	6 ohms
Dimensions (w/h/d)	Approx. 200 × 325 × 230 mm
Mass	Approx. 3.0 kg net per speaker

Mexican model:**Front speaker SS-RG575AV for MHC-RG575S**

Speaker system	3-way, 4-unit, bass-reflex type, magnetically shielded type
Speaker units	
Sub Woofer:	15 cm, cone type
Woofer:	15 cm, cone type
Tweeter:	5 cm × 2, cone type
Nominal impedance	6 ohms
Dimensions (w/h/d)	Approx. 245 × 380 × 240 mm
Mass	Approx. 5.9 kg net per speaker

Sub woofer SS-WG575 for MHC-RG575S

Speaker system	Bass-reflex type
Speaker units	
Woofer:	20 cm, cone type
Nominal impedance	6 ohms
Dimensions (w/h/d)	Approx. 265 × 325 × 365 mm
Mass	Approx. 6.3 kg

Front speaker SS-RG575AV for MHC-RG470

Speaker system	3-way, 4-unit, bass-reflex type, magnetically shielded type
Speaker units	
Sub Woofer:	15 cm, cone type
Woofer:	15 cm, cone type
Tweeter:	5 cm × 2, cone type
Nominal impedance	6 ohms
Dimensions (w/h/d)	Approx. 245 × 380 × 240 mm
Mass	Approx. 5.9 kg net per speaker

Front speaker SS-RG475AV for MHC-RG270

Speaker system	3-way, 3-unit, bass-reflex type, magnetically shielded type
Speaker units	
Woofer:	13 cm, cone type
Sub woofer:	13 cm, cone type
Tweeter:	5 cm, cone type
Nominal impedance	6 ohms
Dimensions (w/h/d)	Approx. 230 × 345 × 235 mm
Mass	Approx. 4.0 kg net per speaker

Other models:**Front speaker SS-RG575 for MHC-RG575S**

Speaker system	3-way, 4-unit, bass-reflex type
Speaker units	
Sub Woofer:	15 cm, cone type
Woofer:	15 cm, cone type
Tweeter:	5 cm × 2, cone type
Nominal impedance	6 ohms
Dimensions (w/h/d)	Approx. 245 × 380 × 290 mm
Mass	Approx. 5.5 kg net per speaker

Sub woofer SS-WG575 for MHC-RG575S

Speaker system	Bass-reflex type
Speaker units	
Woofer:	20 cm, cone type
Nominal impedance	6 ohms
Dimensions (w/h/d)	Approx. 265 × 325 × 365 mm
Mass	Approx. 6.3 kg

Front speaker SS-RG475 for MHC-RG475S

Speaker system	3-way, 3-unit, bass-reflex type
Speaker units	
Sub woofer:	13 cm, cone type
Woofer:	13 cm, cone type
Tweeter:	5 cm, cone type
Nominal impedance	6 ohms
Dimensions (w/h/d)	Approx. 230 × 345 × 235 mm
Mass	Approx. 3.8 kg net per speaker

Sub woofer SS-WG475 for MHC-RG475S

Speaker system	Bass-reflex type
Speaker units	
Woofer:	20 cm, cone type
Nominal impedance	6 ohms
Dimensions (w/h/d)	Approx. 265 × 325 × 330 mm
Mass	Approx. 5.5 kg

Front speaker SS-RG575 for MHC-RG470

Speaker system	3-way, 4-unit, bass-reflex type
Speaker units	
Sub Woofer:	15 cm, cone type
Woofer:	15 cm, cone type
Tweeter:	5 cm × 2, cone type
Nominal impedance	6 ohms
Dimensions (w/h/d)	Approx. 245 × 380 × 290 mm
Mass	Approx. 5.5 kg net per speaker

Front speaker SS-RG475 for MHC-RG270

Speaker system	3-way, 3-unit, bass-reflex type
Speaker units	
Woofer:	13 cm, cone type
Sub woofer:	13 cm, cone type
Tweeter:	5 cm, cone type
Nominal impedance	6 ohms
Dimensions (w/h/d)	Approx. 230 × 345 × 235 mm
Mass	Approx. 3.8 kg net per speaker

Front speaker SS-RG170 for MHC-RG170

Speaker system	3-way, 3-unit, bass-reflex type
Speaker units	
Super Tweeter:	2 cm, dome type
Woofer:	13 cm, cone type
Tweeter:	5 cm, cone type
Nominal impedance	6 ohms
Dimensions (w/h/d)	Approx. 200 × 325 × 230 mm
Mass	Approx. 3.0 kg net per speaker

General

Power requirements

North American model:	120 V AC, 60 Hz
European and Russian models:	230 V AC, 50/60 Hz
Australian model:	230 – 240 V AC, 50/60 Hz
Argentine model:	220 V AC, 50/60 Hz
Mexican model:	127 V AC, 60 Hz
Saudi Arabian model:	120 – 127, 220 or 230 – 240 V AC, 50/60 Hz Adjustable with voltage selector
Other models:	120 V, 220 V or 230 – 240 V AC, 50/60 Hz Adjustable with voltage selector

Power consumption

USA model:	
MHC-GX555:	285 watts
MHC-GX355:	210 watts
Canadian model:	
MHC-GX555:	380 VA
MHC-GX355:	290 VA
MHC-GX255:	110 watts
European and Russian models:	
MHC-RG475S:	300 watts 0.25 watts (at the Power Saving Mode)
MHC-RG470:	240 watts 0.25 watts (at the Power Saving Mode)
MHC-RG270:	190 watts 0.25 watts (at the Power Saving Mode)
MHC-RG170:	70 watts 0.25 watts (at the Power Saving Mode)
Other models:	
MHC-RG575S:	300 watts
MHC-RG475S:	300 watts
MHC-RG470:	170 watts
MHC-RG270:	210 watts
MHC-RG170:	125 watts

Dimensions (w/h/d) (excl. speakers)

Approx. 280 × 325 ×
430 mm

Mass (excl. speakers)

North American models:	
MHC-GX555:	Approx. 10.5 kg
MHC-GX355:	Approx. 10.0 kg
Canadian model:	
MHC-GX555:	Approx. 10.5 kg
MHC-GX355:	Approx. 10.0 kg
MHC-GX255:	Approx. 8.5 kg
European and Russian models:	
MHC-RG475S:	Approx. 10.5 kg
MHC-RG470:	Approx. 10.0 kg
MHC-RG270:	Approx. 8.7 kg
MHC-RG170:	Approx. 7.2 kg
Other models:	
MHC-RG575S:	Approx. 10.5 kg
MHC-RG475S:	Approx. 10.5 kg
MHC-RG470:	Approx. 10.4 kg
MHC-RG270:	Approx. 10.0 kg
MHC-RG170:	Approx. 8.5 kg

Supplied accessories

Remote Commander (1)
R6 (Size AA) batteries (2)
AM loop antenna (1)
FM lead antenna (1)
Video cable (Mexican model only) (1)
Speaker pads
MHC-GX555/RG575S/ RG475S (12)
MHC-GX355/GX255/ RG470/RG270/RG170 (8)

Design and specifications are subject to change
without notice.

Remote control

ALPHABETICAL ORDER

A - E

ALBUM + **[11]** (11, 13)
ALBUM - **[13]** (11, 13)
CD **[18]** (10, 13)
CLEAR **[15]** (13)
CLOCK/TIMER SELECT **[2]**
(23, 24)
CLOCK/TIMER SET **[3]** (9, 22,
23)
DISC SKIP **[10]** (11, 13)
DISPLAY **[21]** (16, 24, 25)
ENTER **[9]** (9, 13, 14, 22, 23)
EQ **[14]** (19)

F - Z

FM MODE **[4]** (16)
FUNCTION **[6]** (10, 13, 14, 15,
17, 27)
PLAY MODE **[20]** (11, 13, 17)
REPEAT **[4]** (12)
SLEEP **[22]** (22)
TAPE **[17]**
TUNER BAND **[5]** (14, 15)
TUNER MEMORY **[19]** (14)
TUNING MODE **[20]** (14, 15)
VOLUME +/- **[12]** (19, 25)

BUTTON DESCRIPTIONS

I/O (power) **[1]** (8, 23)
◀◀/▶▶ (rewind/fast forward)
[7] (11, 17)
▶ (play) **[8]** (11, 17)
⏸ (pause) **[8]** (11, 17)
■ (stop) **[8]** (11, 17)
+/- (tuning) **[16]** (14)
◀◀/▶▶ (go back/go forward)
[16] (9, 11, 17)

