

Installation Instructions

- **Safety Labeling and Rules**
- **Installation Requirements**
- **Location/Clearances**
- **Air Distribution**
- **Wiring**
- **Ductwork Connections**
- **Start-Up**
- **Operation**
- **Maintenance**
- **Inspection**
- **Hoisting/Rigging**

**3 thru 7-1/2 Ton
Belt Drive Models
Electric Cool & Heat**



1. Safety Labeling And Signal Words

DANGER, WARNING AND CAUTION

The signal words **DANGER**, **WARNING** and **CAUTION** are used to identify levels of hazard seriousness. The signal word **DANGER** is only used on product labels to signify an immediate hazard. The signal words **WARNING** and **CAUTION** will be used on product labels and throughout this manual and other manuals that may apply to the product.

SIGNAL WORDS

DANGER – Immediate hazards which **WILL** result in severe personal injury or death.

WARNING – Hazards or unsafe practices which **COULD** result in severe personal injury or death.

CAUTION – Hazards or unsafe practices which **COULD** result in minor personal injury or product or property damage.

Signal Words in Manuals

The signal word **WARNING** is used throughout this manual in the following manner:

WARNING

The signal word **CAUTION** is used throughout this manual in the following manner:

CAUTION

PRODUCT LABELING

Signal words are used in combination with colors and/or pictures on product labels. Following are examples of product labels with explanations of the colors used.

Danger Label

Black printing on a white background except the word **DANGER** which is white with a red background.

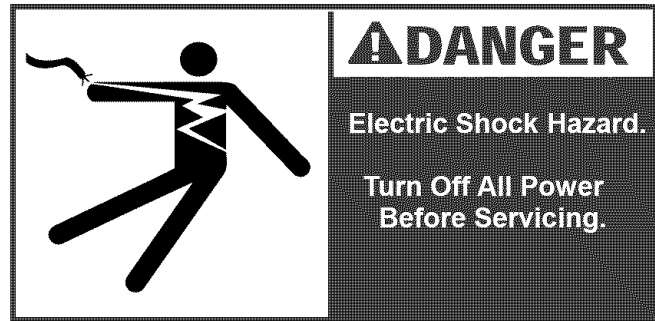

Warning Label

Black printing on a white background except the word **WARNING** which is black with an orange background.

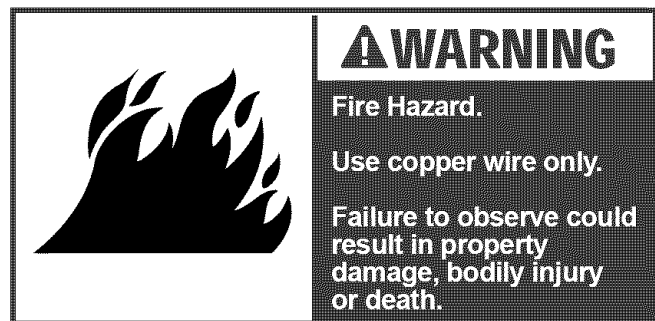

Caution Label

Black printing on a white background except the word **CAUTION** which is black with a yellow background.

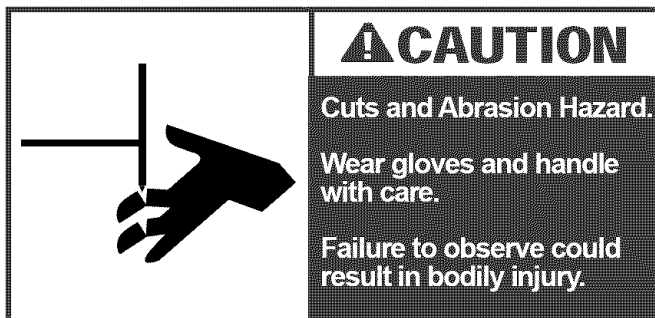

“C” CHASSIS UNIT DIMENSIONS

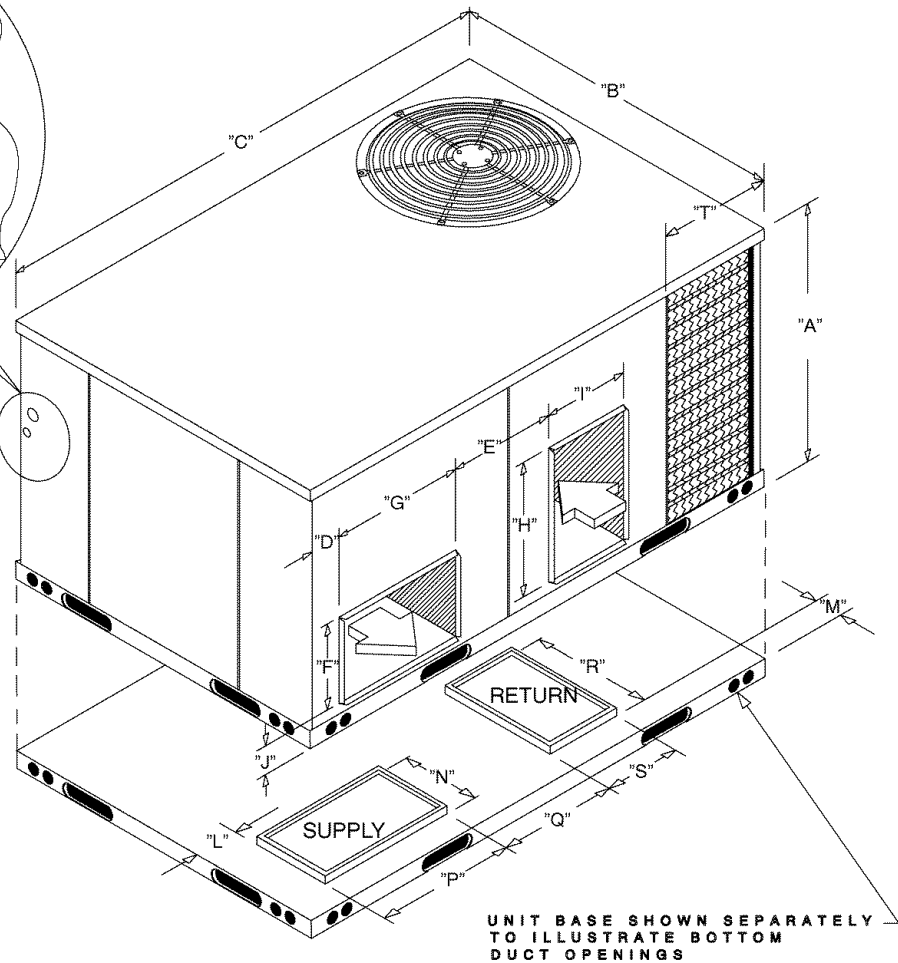
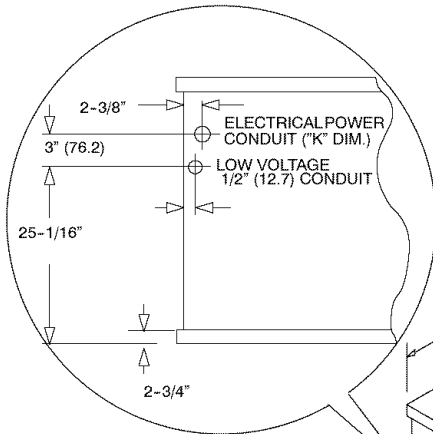

**“C” Chassis
(47³/₈ X 73)**

DIM.	INCHES	MILLIMETERS
A	36	914
B	47-3/8	1203
C	73	1354
D	4-5/8	117
E	15	361
F	12	307
G	18-3/4	476
H	18-3/4	476
I	12	306
J	4	102
K	1 & 1-1/4	25 & 31
L	4-1/4	108
M	5-1/4	133
N	12-1/4	311
P	19	483
Q	15	381
R	19	483
S	12-1/4	318
T	16-7/8	429

**ROOF CURB
for
“C” Chassis
(47³/₈ X 73)**

DIM.	INCHES	MILLIMETERS
A	67-3/4	1721
B	64-3/4	1645
C	23	584
D	23	584
E	2-1/2	64
F	42-3/4	1086
G	39-3/4	1010
H	23	584
I	12	305
J	12	305
K*	14	356

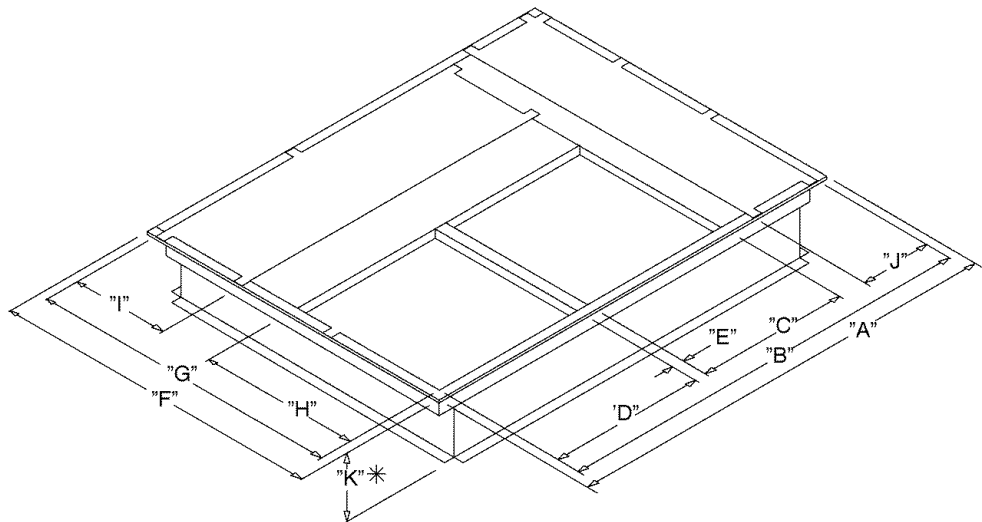

* ROOF CURBS ARE ALSO AVAILABLE IN 8" (203) AND 24" (610) HEIGHTS (K DIMENSION).

2. Safe Installation Requirements

WARNING

Installation or repairs made by unqualified persons can result in hazards to you and others. Installation **MUST** conform with local building codes or, in the absence of local codes, with the National Electrical Code NFPA70-1990 or in Canada the CSA C.22.1 - Canadian Electrical Code Part 1.

The information contained in this manual is intended for use by a qualified service technician familiar with safety procedures and equipped with the proper tools and test instruments.

Failure to carefully read and follow all instructions in this manual can result in furnace malfunction, property damage, personal injury and/or death.

NOTE: It is the personal responsibility and obligation of the customer to contact a qualified installer to ensure that the installation is adequate and conforms to governing codes and ordinances.

3. Locating the Unit

The unit is designed for outdoor installation only. The unit may be installed on a concrete mounting base at ground level, or on a rooftop with an adequate platform or if using as a downflow model, with a roof curb.

Access Panels

See **Figure 1** below for a general view of unit and location of access panels.

WARNING

Carbon monoxide poisoning hazard.
 Keep blower door closed.
 Failure to keep blower door closed can result in bodily injury and/or death.

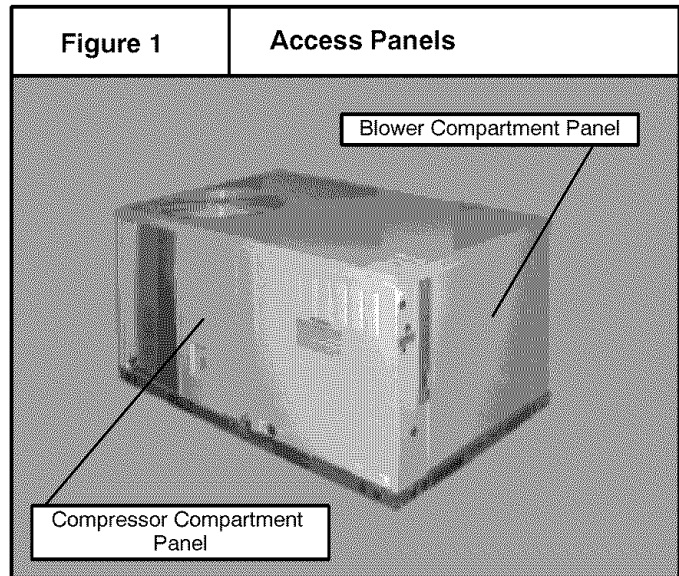

Clearances

The location **MUST** allow for minimum clearances and should not be adjacent to a patio or other area where the unit's operating sound level might be objectionable.

Clearances **MUST** be maintained from adjacent structures to provide adequate fire protection and room for service personnel.

NOTE: Filter racks need a 26" minimum clearance at front of unit for removal of filters. See chart below if unit is going to be placed near combustible construction or materials.

While minimum clearances are acceptable for safety reasons, they may not allow adequate air circulation around the unit for proper operation in the cooling mode. Whenever possible, it is desirable to allow additional clearance, especially around the condenser inlet and discharge openings.

Do **NOT** install the unit in a location that will permit discharged air from the condenser to recirculate to the condenser inlet.

CAUTION

Do NOT operate unit in a corrosive atmosphere containing chlorine, fluorine, or any other corrosive chemicals.

Minimum Clearances to Combustible Construction

Duct Side	6"
Condenser Inlet Side	30"
Blower Service (Rear)	30"
Control Service Side	
Clearance between 3 Ft. maximum overhang and Top of Unit	30"

Ground Level Installation

Provide a level wood platform (pressure treated) or a concrete mounting base at least 4" thick and separate from the building foundation. The base surface should be 4" above grade level in an area that is well drained.

CAUTION

Unit will **NOT** operate properly unless it is installed level front to rear and side to side.

Rooftop Installation

The existing roof structure **MUST** be adequate to support the weight of the unit or the roof **MUST** be reinforced. Check the weight of the unit in relation to the roof structure and local building codes or ordinances and reinforce if necessary.

The unit **MUST** be situated to provide safe access for servicing. Support for the unit **MUST** be level and may consist of a platform or a combination of platform and roof beams or curb. The platform may be constructed of combustible material (wood only), or covered with Class A, B or C roof covering.

Hoisting

The unit should be hoisted with two lifting slings. Attach the slings to rigging shackles that have been hooked through holes in the base rail.

Place a short piece of 2x4 between unit and sling near the top edge to protect unit from damage. Two spreader bars **MUST** be used to keep slings from possibly crushing the sheet metal or damaging the unit. Make sure equipment is adequate for weight of unit, and that slings will not allow unit to shift. Refer to **Figure 18**, last page of these instructions for illustrated rigging instructions.

Downflow Conversion

These units are adaptable to downflow use. To convert to downflow use, follow these steps:

1. Remove the blockoff plates found in the return air compartment and the supply air compartment. See **Figure 2** and **Figure 3**.

NOTE: Blockoff plate in the supply air compartment only contains one screw. If reinstalling plate, back part of plate **MUST** fit into mating dimples on flange. To reinstall, slant plate into dimples, then put plate into position and fasten with screw.

2. Install the removed plates on the horizontal return and supply air openings.
3. Install roof curb on your building. Be sure to follow all directions included with curb and all applicable building codes.
4. Install unit on the appropriate roof curb.

NOTE: It is the installer's personal responsibility to follow all local codes and ordinances and instructions contained herein, as well as instructions included with accessory items when installing unit.

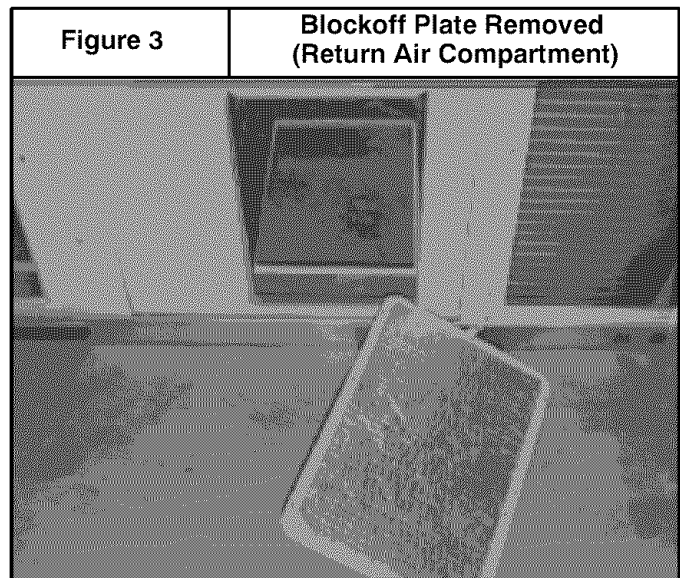
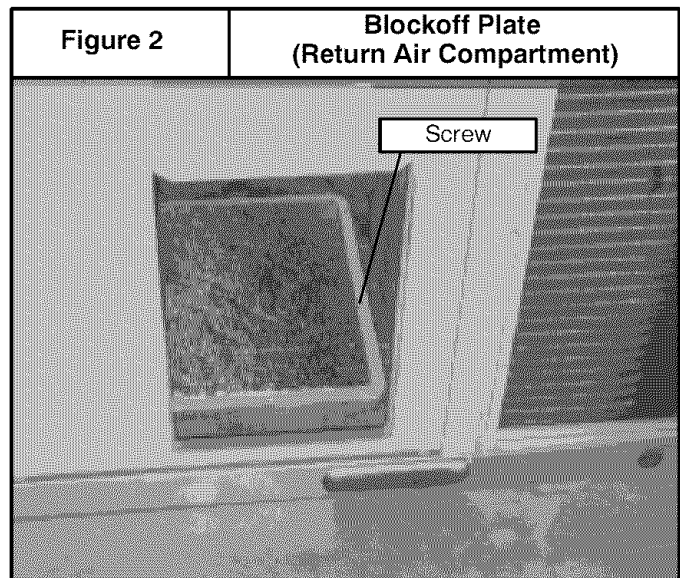
**Condensate Trap**

A condensate trap **MUST** be installed as near the unit as possible for proper drainage. Condensate trap **MUST** have proper height and fall as shown in **Figure 4**.

Condensate Drain

A $\frac{3}{4}$ " O.D. condensate drain connection is located at the front end of the unit. A $\frac{3}{4}$ " drain line **MUST** be installed if required by local codes or location of unit, and run to an open drain or other suitable disposal point.

Figure 4

Condensate Trap

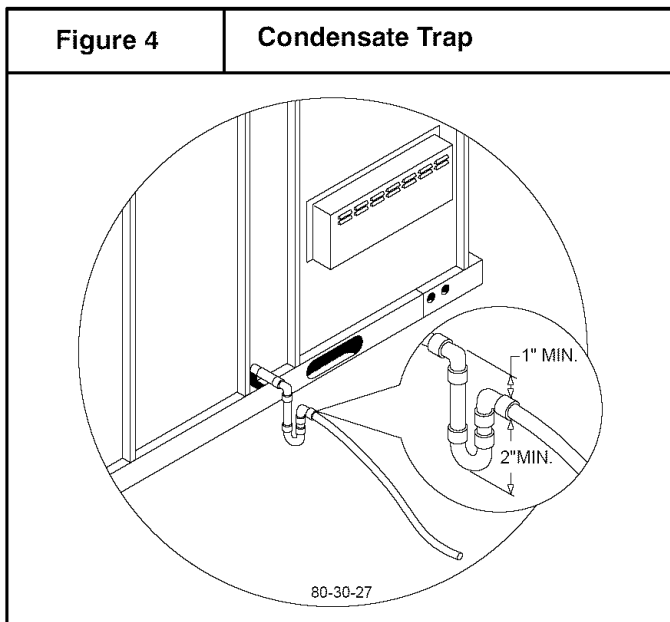

4. Electrical Wiring

WARNING

Electrical shock hazard.

Disconnect power at fuse box or service panel before making any electrical connections. Unit **MUST** be grounded to electrical service panel.

Failure to follow this warning can result in property damage, personal injury, and/or death.

NOTE: All electrical work **MUST** conform with the requirements of local codes and ordinances and the National Electrical Code ANSI/NFPA-No. 70-1990 or current edition. Provide line voltage power supply from a separate protected circuit with a disconnect switch (when required) located within sight of the unit. Supply voltage, amperage, wire, fuse and disconnect switch sizes **MUST** conform with specifications in the *Technical Data* and with unit rating plate.

All exposed wiring or connections **MUST** be made with weatherproof cable or wire unless installed in conduit. Wiring **MUST** be protected from possible mechanical damage. Connections for line voltage are made in the unit control box. Low voltage connections are made outside the control box. For access, remove the burner access panel and the control box cover. See **Figure 1**.

Low Voltage Wiring

Low voltage wiring connections for the thermostat are made at the 24V terminal board outside the control box. Refer to the wiring diagram for the applicable model and the instructions included with the thermostat.

Thermostat

NOTE: Do **NOT** attempt to use a thermostat designed for heat pump use. Such thermostats will **NOT** control the unit properly.

The location of the thermostat has an important effect on the operation of the unit. **FOLLOW THE INSTRUCTIONS INCLUDED WITH THE THERMOSTAT FOR CORRECT LOCATION, MOUNTING, AND WIRING.**

Heat Anticipator

Set the thermostat heat anticipator to .58 in accordance with thermostat instructions.

Line Voltage Wiring

Connections for line voltage are made in the unit control box. For access, remove the burner access panel and the control box cover.

Do **NOT** complete line voltage connections until unit is permanently grounded. All line voltage connections and the ground connection **MUST** be made with copper wire.

Ground Connections

A ground lug is installed in the control box for the ground connection. Use a copper conductor of the appropriate size from the unit to a grounded connection in the electrical service panel.

Line Connections

Complete the line service connections to the contactor 'L' terminals inside the control box. Refer to applicable wiring diagram in *Technical Data*. Check all screw terminals to ensure they are tight.

Field Installed Equipment

Wiring to be done in the field between the unit and devices not attached to the unit, or between separate devices which are field installed and located, shall conform with the temperature limitations for type of wire used and shall be installed with the manufacturer's instructions and the National Electrical Code as it applies to such devices.

Final Electrical Check

Make a final wiring check to be sure system is correctly wired. Inspect field installed wiring and the routing to ensure that rubbing or chafing due to vibration will not occur.

5. Air Distribution System

Ductwork

NOTE: The total heat loss from the structure as expressed in total Btu/hr(Kw) **MUST** be calculated by manufacturer's method or in accordance with "A.S.H.R.A.E. Guide" or "Manual N - Load Calculations" published by the Air Conditioning Contractors of America or in Canada H.R.A.I. "Manual N". The total heat loss calculated should be equal to or less than the unit heating capacity, output based on D.O.E. test procedures, steady state efficiency times input.

Ductwork, supply registers, and return air grilles **MUST** be designed and sized to handle the greater of the units heating or cooling air volume requirements. If the unit is connected to an existing system, the ductwork **MUST** be checked to make sure it is adequate. Extra runs or larger duct sizes may have to be installed. **Use only non-combustible type insulation on supply plenum or supply ductwork within 6 feet(2m) of unit.**

Maximum recommended velocity in supply trunk ducts is 1000 feet (305m) per minute and 800 feet (244m) per minute in return trunk ducts. Velocity in branches should not exceed 800 feet (244m) per minute supply and 600 feet (183m) per minute in the return.

Ductwork installed outdoors should have a minimum of 2" (50.8mm) of fiberglass insulation and a weatherproof vapor barrier. It should also be protected against damage. Caulk and flashing, or other means adequate to provide a permanent weather seal should be used.

Ductwork installed in attics or other areas exposed to outside temperatures should be installed with a minimum of 2" (50.8mm) fiberglass insulation and have an indoor type vapor barrier.

The use of flexible, **non-combustible** connectors between main trunk ducts and supply and return air plenums is recommended to minimize vibration transmission .

NOTE: Connect supply and return air plenums to unit in a manner that will allow the top of the unit to be removed without removing plenums. Plenums **MUST** be *individually* sealed to unit casing.

Filters

CAUTION

Do NOT operate the unit without all filters in place.

All air **MUST** pass through a filter before entering the unit. Electronic air cleaner, optional filter racks, or other accessible filter arrangements **MUST** be installed in the return air ductwork.

NOTE: If the unit has an economizer or any other type of outdoor air damper, disposable filters **MUST** be used in the internal filter racks.

For replacement filter sizes and instructions, see *Air Filters*.

Circulating Blower

Determining Pulley Turns

1. From the system design, determine the external static pressure (ESP) for the supply ducts, return ducts and registers, diffusers, grilles, dampers, heaters and special filters (if any).
2. If unit is to be set up in cooling mode, add .08" W.C. (20 Pa) for wet coil operation to the total ESP determined in Step 1.
3. From the system design, determine the desired airflow in CFM (L/s).
4. To determine the pulley turns necessary to obtain the desired CFM (L/s), go to the Circulating Blower Performance Data graph for the unit.

Figure 5

Circulating Blower Performance Data - 3 Ton Units 208 Volts

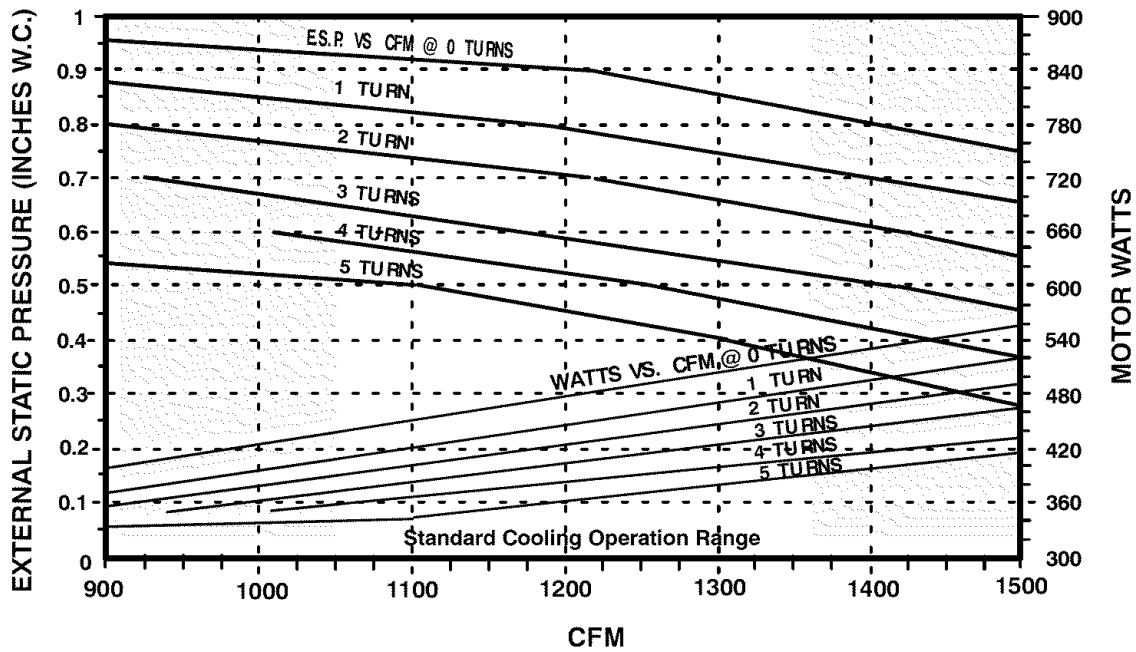

NOTES: 1) Maximum motor Watts is 787 Watts. 2) Maximum blower speed is 1400 RPM. 3) Contact factory for applications requiring operation outside standard cooling operating range. 4) Airflow data is based on dry coil with filters. 5) Pulley turns refers to turns out. In other words, 0 turns is a *narrower* sheave than 5 turns. 6) Blower speed **MUST** be set to give the correct air temperature rise through the unit as marked on the Rating Plate on in the *Technical Support Manual*

NUMBER OF TURNS	EXTERNAL STATIC PRESSURE IN INCHES WATER COLUMN														
	.2			.4			.6			.8			1.0		
	CFM	WATTS	RPM	CFM	WATTS	RPM	CFM	WATTS	RPM	CFM	WATTS	RPM	CFM	WATTS	RPM
0										1421	535	920			
1							1614	552	880	1183	448	888			
2							1418	470	844						
3				1587	478	804	1206	399	809						
4				1446	419	766									
5	1615	433	724	1301	375	727									

PULLEY TURNS OPEN	0	1	2	3	4	5
RPM WITH .75 HP STD PULLEY	909	878	842	807	768	730

FACTORY SETTING TURNS OPEN	
.75 HP STD PULLEY	5

Figure 6

Circulating Blower Performance Data - 3 Ton Units 230 / 460 Volts

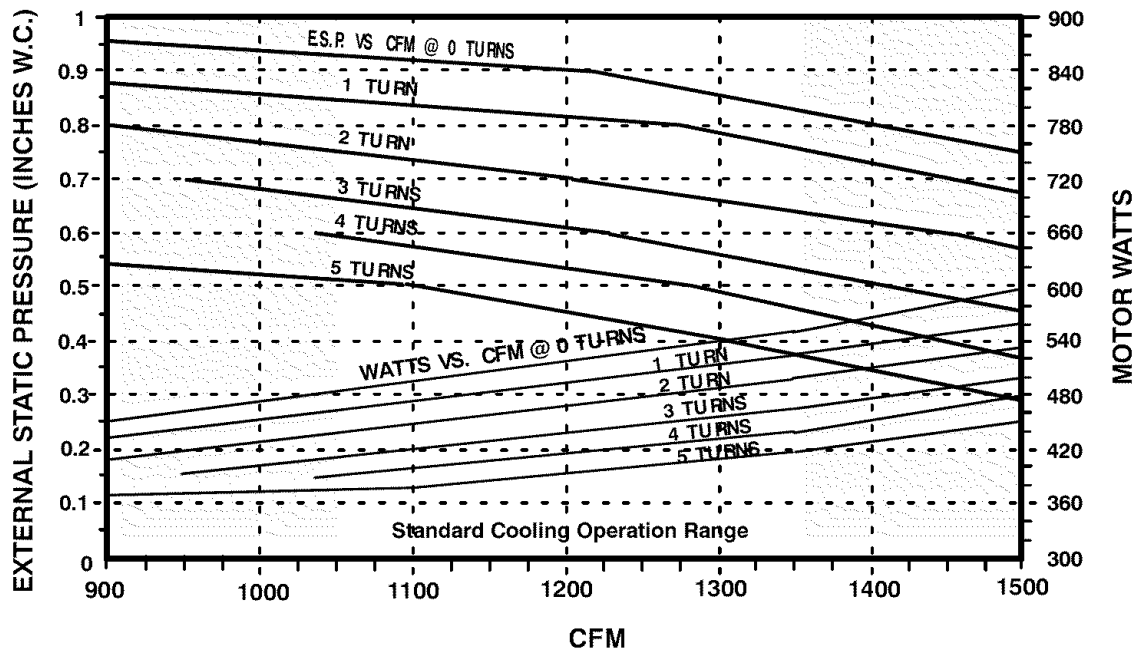

NOTES: 1) Maximum motor Watts is 808 Watts. 2) Maximum blower speed is 1400 RPM. 3) Contact factory for applications requiring operation outside standard cooling operating range. 4) Airflow data is based on dry coil with filters. 5) Pulley turns refers to turns out. In other words, 0 turns is a narrower sheave than 5 turns. 6) Blower speed MUST be set to give the correct air temperature rise through the unit as marked on the Rating Plate on in the *Technical Support Manual*

NUMBER OF TURNS	EXTERNAL STATIC PRESSURE IN INCHES WATER COLUMN														
	.2			.4			.6			.8			1.0		
	CFM	WATTS	RPM	CFM	WATTS	RPM	CFM	WATTS	RPM	CFM	WATTS	RPM	CFM	WATTS	RPM
0										1420	575	925			
1							1623	594	885	1264	509	891			
2							1453	521	848						
3				1599	520	807	1222	442	811						
4				1455	467	769	1032	393	772						
5	1604	467	727	1318	418	730									

PULLEY TURNS OPEN	0	1	2	3	4	5
RPM WITH .75 HP STD PULLEY	915	883	846	809	771	732

FACTORY SETTING TURNS OPEN	
.75 HP STD PULLEY	5

Figure 7

Circulating Blower Performance Data - 4 Ton Units 208 Volts

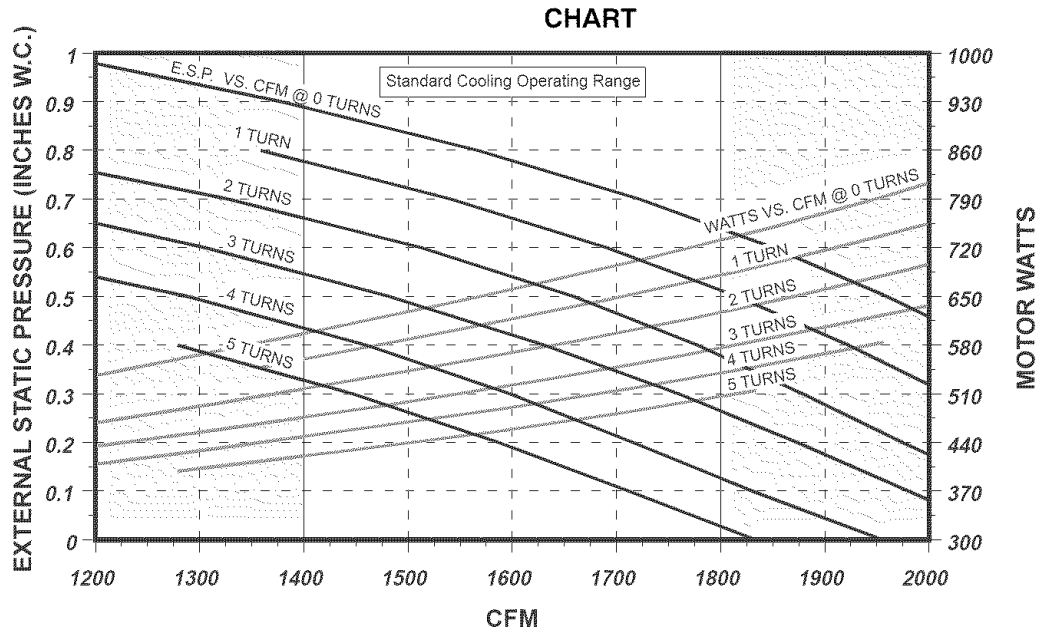

NOTES:

1. Maximum motor Watts is 928 Watts.
2. Airflow based on dry coil, horizontal flow, with filters.
3. For downflow SCFM, use a .15 static drop.
4. Pulley turns refer to turns out. I.E. 0 turns is a narrower sheave than 5 turns.
5. For applications requiring operation in shaded areas, contact the factory.
6. Maximum blower wheel speed is 1400 RPM.
7. The blower speed MUST be set to give the correct air temperature rise through the unit as marked on the Rating Plate or Technical Support Manual.

TABLE

NO. OF TURNS	EXTERNAL STATIC PRESSURE IN INCHES W.C.														
	.2			.4			.6			.8			1.0		
	CFM	W	WHL RPM	CFM	W	WHL RPM	CFM	W	WHL RPM	CFM	W	WHL RPM	CFM	W	WHL RPM
0							1851	750	952	1567	649	960			
1							1691	645	913	1359	548	920			
2				1778	620	867	1513	546	871						
3				1631	530	822									
4	1716	518	774	1460	461	777									
5	1587	456	725												

TURNS/RPM CONVERSION TABLE

PULLEY TURNS OPEN	0	1	2	3	4	5
RPM WITH .75 HP STD PULLEY	950	910	870	825	780	730

W = Watts

UNIT	FACTORY SETTING TURNS OPEN
PGB048D	.75 HP STD PULLEY 3.5
PGB048F	.75 HP STD PULLEY 2

Figure 8

Circulating Blower Performance Data - 4 Ton Units 230/460/575 Volts

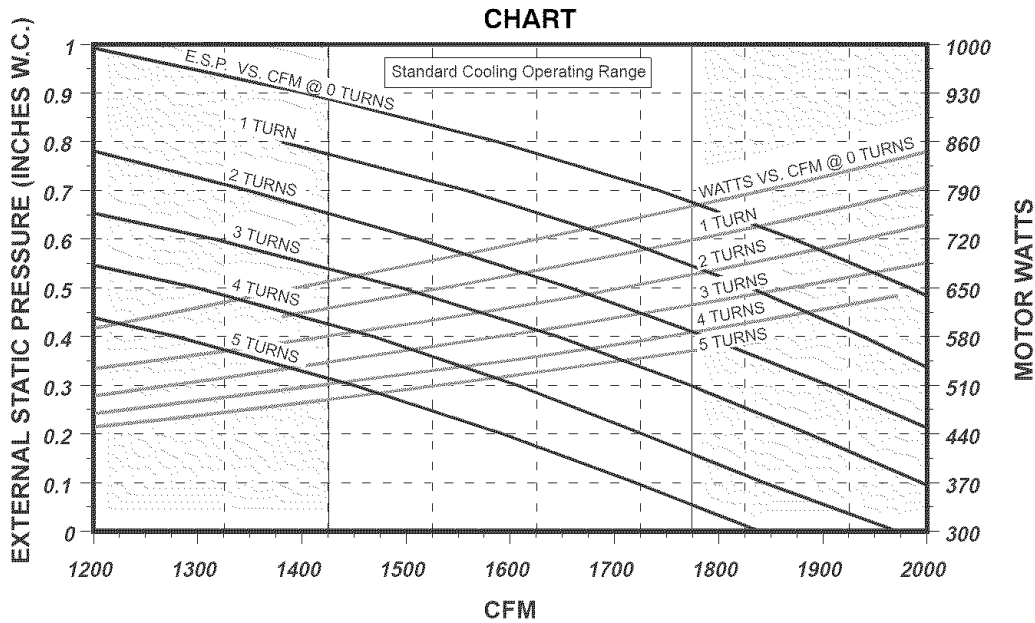

NOTES:

1. Maximum motor Watts is 962 Watts.
2. Airflow based on dry coil, horizontal flow, with filters.
3. For downflow SCFM, use a .15 static drop.
4. Pulley turns refer to turns out. I.E. 0 turns is a *narrower* sheave than 5 turns.
5. For applications requiring operation in shaded areas, contact the factory.
6. Maximum blower wheel speed is 1400 RPM.
7. The blower speed **MUST** be set to give the correct air temperature rise through the unit as marked on the Rating Plate or Technical Support Manual.

TABLE

NO. OF TURNS	EXTERNAL STATIC PRESSURE IN INCHES W.C.														
	.2			.4			.6			.8			1.0		
	CFM	W	WHL RPM	CFM	W	WHL RPM	CFM	W	WHL RPM	CFM	W	WHL RPM	CFM	W	WHL RPM
0							1873	800	959	1588	708	965			
1							1706	698	919	1381	609	925			
2				1788	673	870	1512	600	874						
3				1646	593	825	1317	519	829						
4	1727	574	776	1469	520	778									
5	1593	522	728												

TURNS/RPM CONVERSION TABLE

PULLEY TURNS OPEN	0	1	2	3	4	5
RPM WITH .75 HP STD PULLEY	960	920	875	825	780	730

W = Watts

UNIT	FACTORY SETTING TURNS OPEN
PGB048D	.75 HP STD PULLEY 3.5
PGB048F	.75 HP STD PULLEY 2

Figure 9

Circulating Blower Performance Data - 5 Ton Units 208 Volts

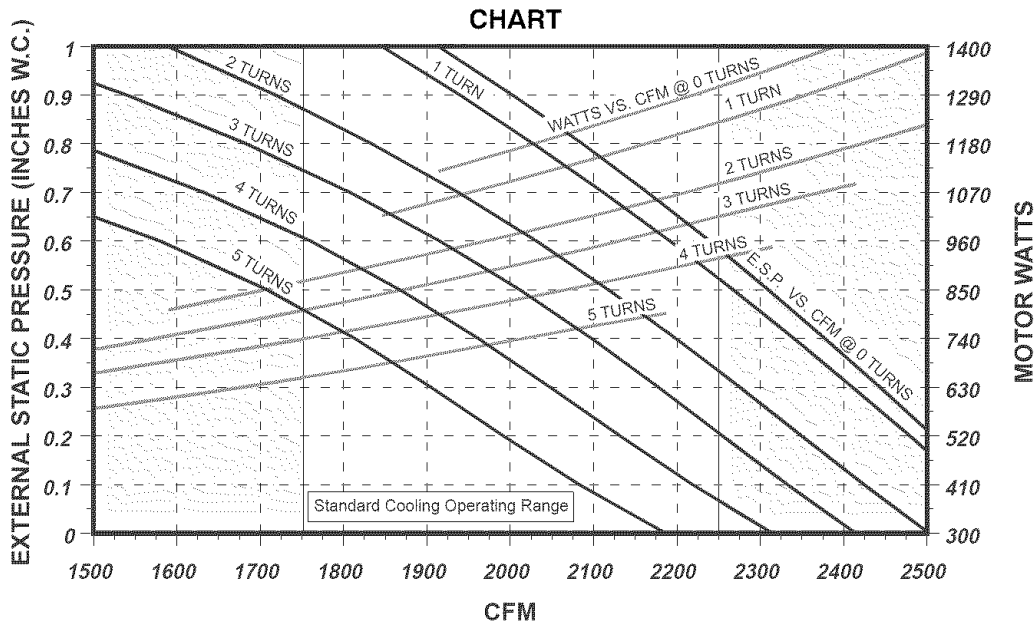

NOTES:

1. Maximum motor Watts is 1486 Watts.
2. Airflow based on dry coil, horizontal flow, with filters.
3. For downflow SCFM, use a .15 static drop.
4. Pulley turns refer to turns out. I.E. 0 turns is a narrower sheave than 5 turns.
5. For applications requiring operation in shaded areas, contact the factory.
6. Maximum blower wheel speed is 1400 RPM.
7. The blower speed MUST be set to give the correct air temperature rise through the unit as marked on the Rating Plate or Technical Support Manual.

TABLE

NO. OF TURNS	EXTERNAL STATIC PRESSURE IN INCHES W.C.														
	.2			.4			.6			.8			1.0		
	CFM	W	WHL RPM	CFM	W	WHL RPM	CFM	W	WHL RPM	CFM	W	WHL RPM	CFM	W	WHL RPM
0							2240	1302	1153	2087	1213	1163	1914	1118	1174
1							2192	1196	1127	2028	1109	1137	1846	1017	1145
2				2199	1064	1074	2032	987	1082	1834	903	1089			
3	2255	1018	1025	2098	945	1031	1916	868	1037						
4	2132	875	982	1962	811	986	1761	742	991						
5	1992	732	938	1814	671	942									

TURNS/RPM CONVERSION TABLE

PULLEY TURNS OPEN	0	1	2	3	4	5
RPM WITH 1 HP STD PULLEY	1145	1120	1080	1035	990	945

W = Watts

FACTORY SETTING TURNS OPEN
1 HP STD PULLEY 2.5

Figure 10

Circulating Blower Performance Data - 5 Ton Units 230/460/575 Volts

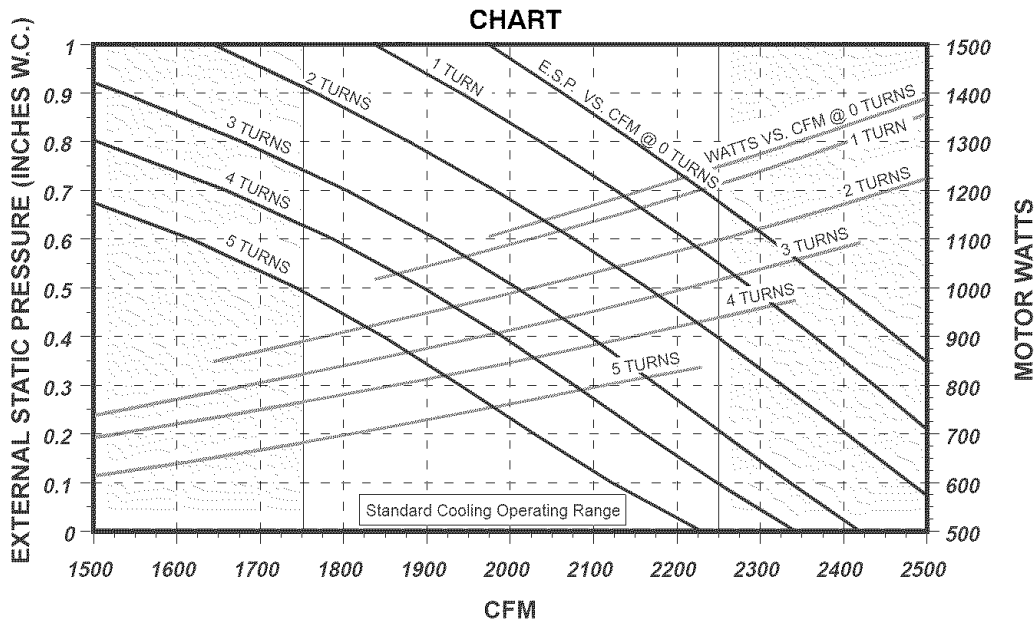

NOTES:

1. Maximum motor Watts is 1454 Watts.
2. Airflow based on dry coil, horizontal flow, with filters.
3. For downflow SCFM, use a .15 static drop.
4. Pulley turns refer to turns out. I.E. 0 turns is a narrower sheave than 5 turns.
5. For applications requiring operation in shaded areas, contact the factory.
6. Maximum blower wheel speed is 1400 RPM.
7. The blower speed MUST be set to give the correct air temperature rise through the unit as marked on the Rating Plate or Technical Support Manual.

TABLE

NO. OF TURNS	EXTERNAL STATIC PRESSURE IN INCHES W.C.														
	.2			.4			.6			.8			1.0		
	CFM	W	WHL RPM	CFM	W	WHL RPM	CFM	W	WHL RPM	CFM	W	WHL RPM	CFM	W	WHL RPM
0							2312	1282	1179	2149	1195	1186	1974	1105	1193
1							2211	1192	1147	2037	1106	1153	1837	1017	1158
2				2248	1097	1087	2077	1021	1091	1879	940	1096			
3	2256	1019	1037	2096	950	1042	1912	880	1046						
4	2161	905	990	1991	843	993	1788	777	996						
5	2029	771	944	1848	712	946									

TURNS/RPM CONVERSION TABLE

PULLEY TURNS OPEN	0	1	2	3	4	5
RPM WITH 1 HP STD PULLEY	1175	1145	1090	1045	1000	950

W = Watts

FACTORY SETTING TURNS OPEN
1 HP STD PULLEY 2.5

BELT DRIVE BLOWER PERFORMANCE DATA - 6-1/3 TON UNITS - 208 VOLTS

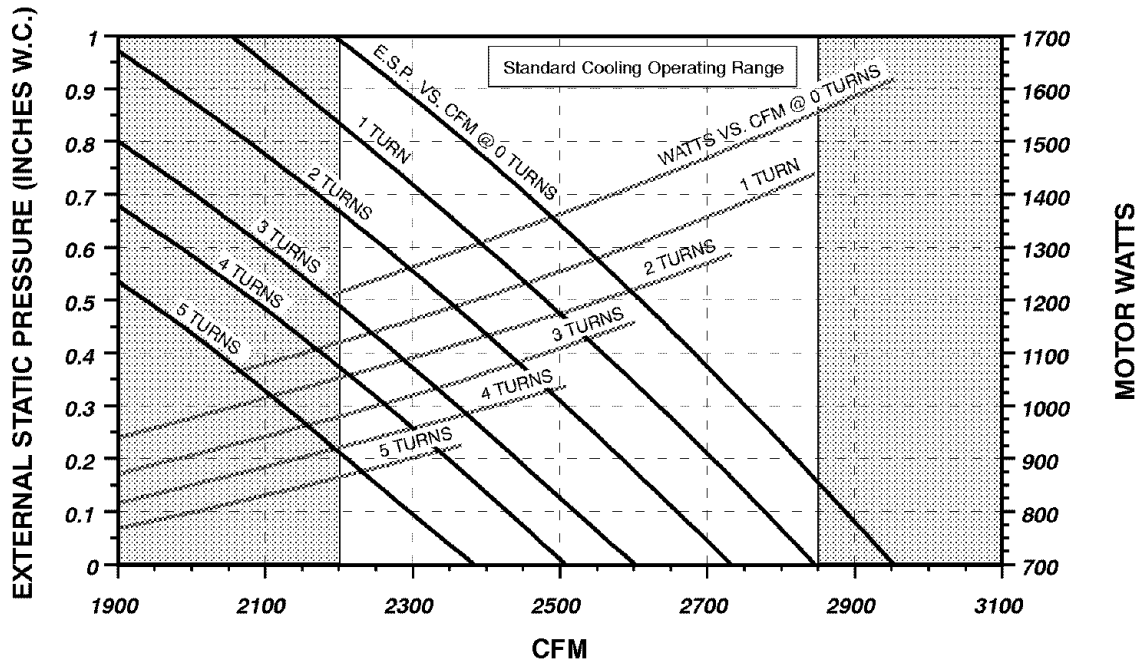

NOTES: 1) Maximum motor Watts is 1538 Watts. 2) Maximum blower speed is 1400 RPM. 3) Contact factory for applications requiring operation outside standard cooling operating range. 4) Airflow data is based on dry coil with filters. 5) Pulley turns refers to turns out. In other words, 0 turns is a narrower sheave than 5 turns. 6) Blower speed MUST be set to give the correct air temperature rise through the unit as marked on the Rating Plate on in the *Technical Support Manual*

NUMBER OF TURNS	EXTERNAL STATIC PRESSURE IN INCHES WATER COLUMN														
	.2			.4			.6			.8			1.0		
	CFM	WATTS	RPM	CFM	WATTS	RPM	CFM	WATTS	RPM	CFM	WATTS	RPM	CFM	WATTS	RPM
0	2820	1538	1239	2682	1460	1242	2534	1380	1246	2372	1298	1249			
1	2707	1361	1198	2558	1283	1200	2399	1207	1203	2231	1133	1205			
2	2584	1213	1154	2429	1145	1156	2262	1077	1158						
3	2441	1081	1108	2278	1011	1110									
4	2348	976	1061												
5	2211	863	1014												

NOTE: For entering air flow correction factors and voltage correction factors for cooling and heating, see page 7. Will operate at rated ESP in either horizontal or downflow duct position.

PULLEY TURNS OPEN	0	1	2	3	4	5
RPM WITH 2 HP STD PULLEY	1245	1202	1157	1111	1064	1017

FACTORY SETTING TURNS OPEN	
2 HP STD PULLEY	2

BELT DRIVE BLOWER PERFORMANCE DATA 6-1/3 TON UNITS - 240, 460 & 575 VOLTS

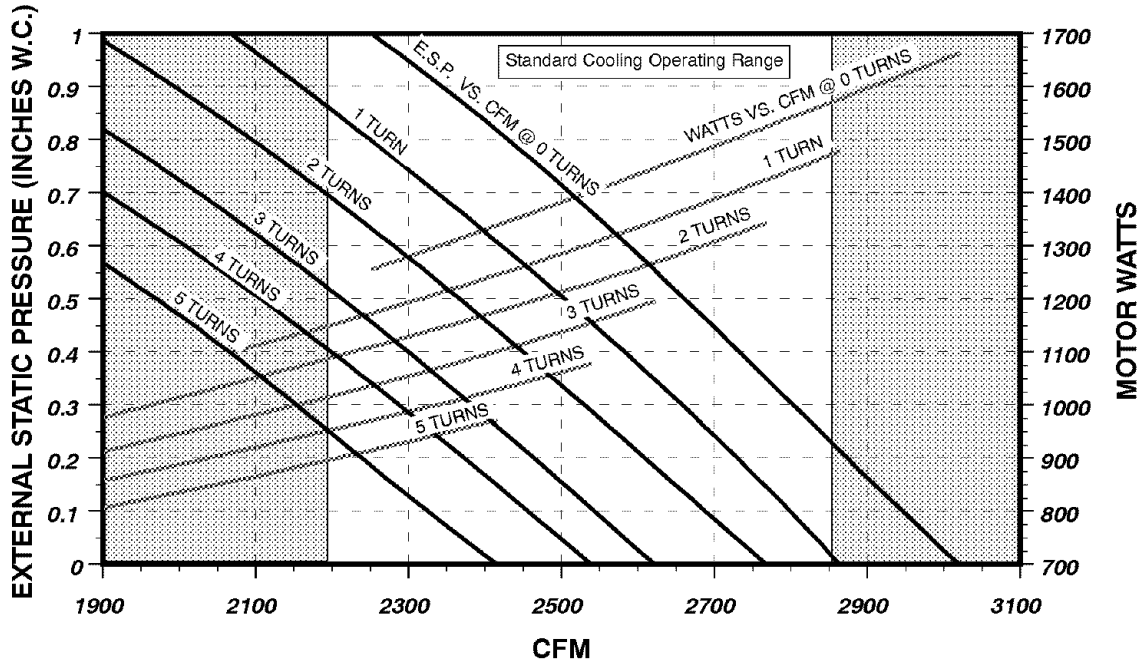

NOTES: 1) Maximum motor Watts is 1582 Watts. 2) Maximum blower speed is 1400 RPM. 3) Contact factory for applications requiring operation outside standard cooling operating range. 4) Airflow data is based on dry coil with filters. 5) Pulley turns refers to turns out. In other words, 0 turns is a narrower sheave than 5 turns. 6) Blower speed MUST be set to give the correct air temperature rise through the unit as marked on the Rating Plate on in the *Technical Support Manual*

NUMBER OF TURNS	EXTERNAL STATIC PRESSURE IN INCHES WATER COLUMN														
	.2			.4			.6			.8			1.0		
	CFM	WATTS	RPM	CFM	WATTS	RPM	CFM	WATTS	RPM	CFM	WATTS	RPM	CFM	WATTS	RPM
0				2733	1505	1250	2588	1428	1253	2430	1346	1255	2251	1255	1258
1	2730	1404	1205	2583	1327	1207	2422	1248	1209	2250	1172	1211			
2	2609	1263	1159	2450	1191	1161	2281	1121	1163						
3	2464	1122	1112	2300	1055	1114									
4	2373	1013	1065	2199	953	1067									
5	2239	910	1017												

NOTE: For entering air flow correction factors and voltage correction factors for cooling and heating, see page 7. Will operate at rated ESP in either horizontal or downflow duct position.

PULLEY TURNS OPEN	0	1	2	3	4	5
RPM WITH 2 HP STD PULLEY	1255	1210	1165	1115	1070	1020

FACTORY SETTING TURNS OPEN	
2 HP STD PULLEY	2

BELT DRIVE BLOWER PERFORMANCE DATA - 7-1/2 TON UNIT

230, 460 VOLT

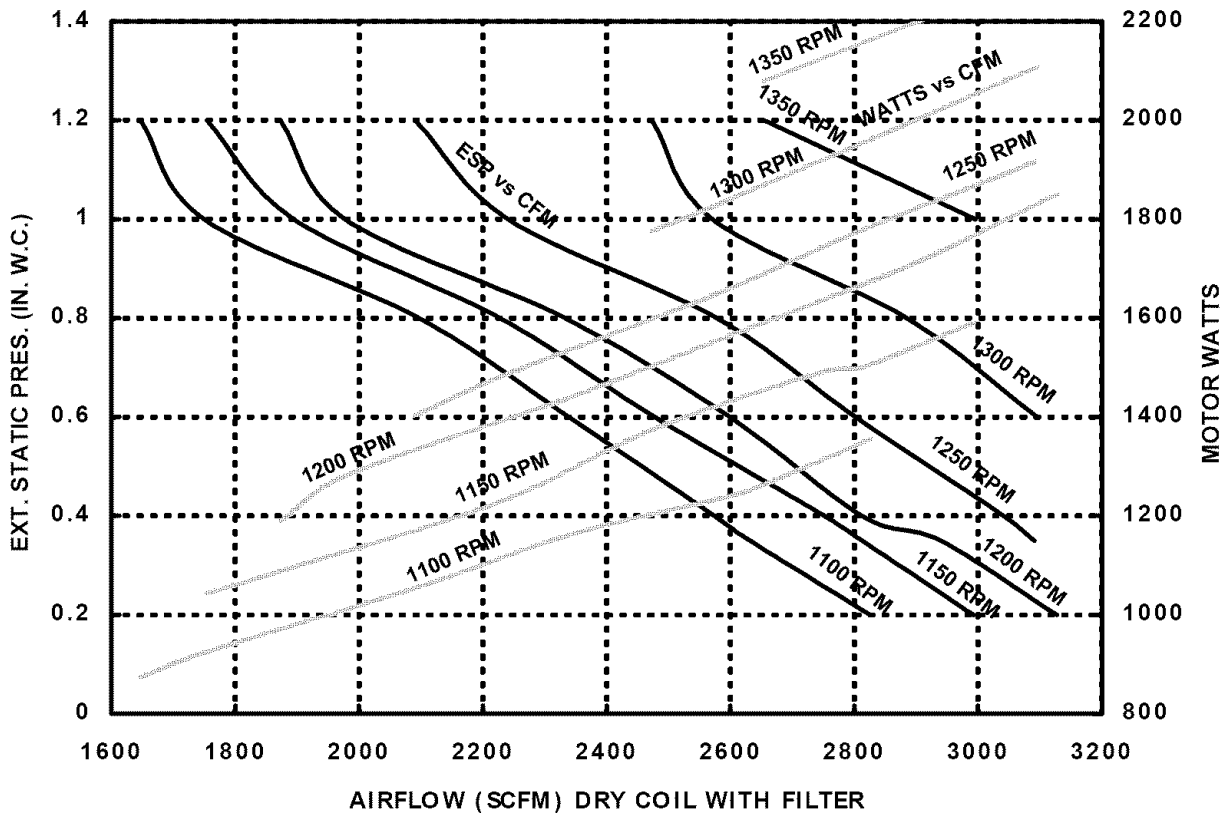

NOTES: 1) Maximum motor Watts is 2158 Watts at 208V, and 2246 Watts at 230-460V. 2) Maximum blower speed is 1400 RPM. 3) Contact factory for applications requiring operation outside standard cooling operating range. 4) Airflow data is based on dry coil with filters. 5) Pulley turns refers to turns out. In other words, 0 turns is a narrower sheave than 5 turns. 6) Blower speed **MUST** be set to give the correct air temperature rise through the unit as marked on the Rating Plate. 7) Add 0.05 in. ESP for 208 volt operation.

VOLTS	TURNS OPEN	EXTERNAL STATIC PRESSURE IN INCHES WATER COLUMN																	
		.2			.4			.6			.8			1.0			1.2		
		CFM	WATT	RPM	CFM	WATT	RPM	CFM	WATT	RPM	CFM	WATT	RPM	CFM	WATT	RPM	CFM	WATT	RPM
230 / 460	0													2996	2246	1345	2654	2077	1355
	1							3095	2107	1295	2885	1992	1297	2571	1825	1300	2473	1775	1305
	2				3041	1890	1240	2802	1772	1242	2578	1649	1245	2241	1487	1253	2091	1403	1255
	3	3127	1850	1180	2812	1667	1190	2599	1564	1192	2333	1436	1195	1978	1281	1196	1873	1188	1200
	4	2993	1590	1126	2752	1492	1133	2478	1376	1136	2228	1228	1140	1895	1096	1142	1754	1043	1145
	5	2826	1355	1075	2574	1232	1080	2339	1161	1082	2097	1056	1085	1750	923	1088	1647	873	1090

VOLTAGE	PULLEY TURNS OPEN	0	1	2*	3	4	5
230 - 460	RPM WITH 2 HP STD PULLEY	1344	1299	1245	1191	1136	1082

* Factory Setting Turns Open

6. Adjustable Belt Drive Blower

WARNING

Personal injury hazard.

Use extreme care during the following procedures and obey Safety Information.

Failure to do so may result in personal injury.

The following safety rules **MUST** always be followed when working near belt drive.

Always Turn The Power Off

Turn the power to the unit **OFF** before you begin working on it.

Always Wear Protective Clothing

NEVER wear loose or bulky clothes, such as neckties, exposed shirttails, loose sleeves, or lab coats around belt drives. Wear gloves while inspecting sheaves to avoid nicks, burrs, or sharply worn pulley edges.

The blower speed is changed by adjusting the variable speed pulley mounted on the blower motor.

If the blower speed needed is different than the speed of the blower as shipped, follow the steps below to change the blower speed. Before changing the blower speed, read the above safety rules first.

5. Turn electric power **OFF**.
6. Remove the side blower access panel (see **Figure 1** on **Page 4**)

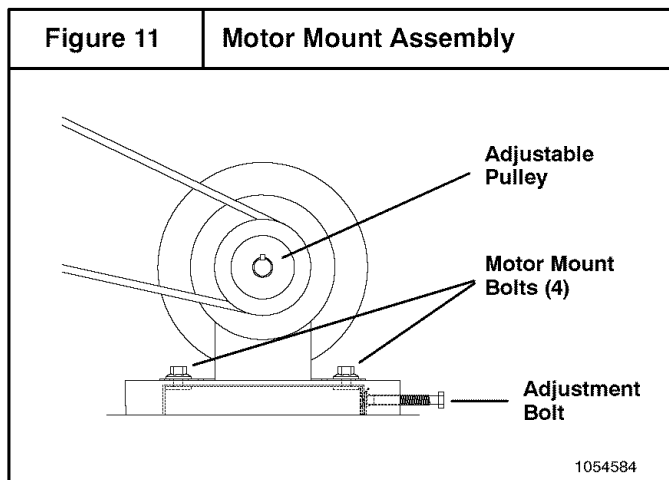

7. Loosen the four motor mount bolts.
8. Turn the motor adjustment bolt counterclockwise until the belt is slack enough to come off easily (see **Figure 11**).
9. Remove the belt. Do **NOT** pry off belt.

10. Loosen set screw(s) on the outer half of the adjustable pulley.

The unit has one of two different types of adjustable pulleys (see **Figure 12** and **Figure 13**).

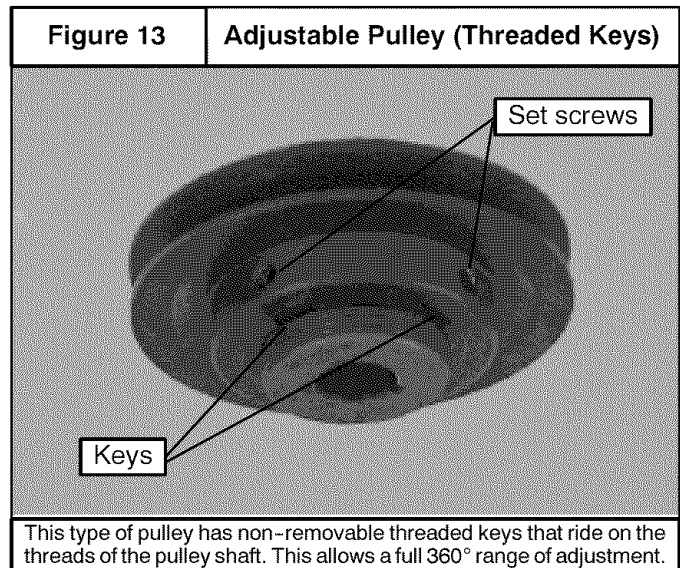
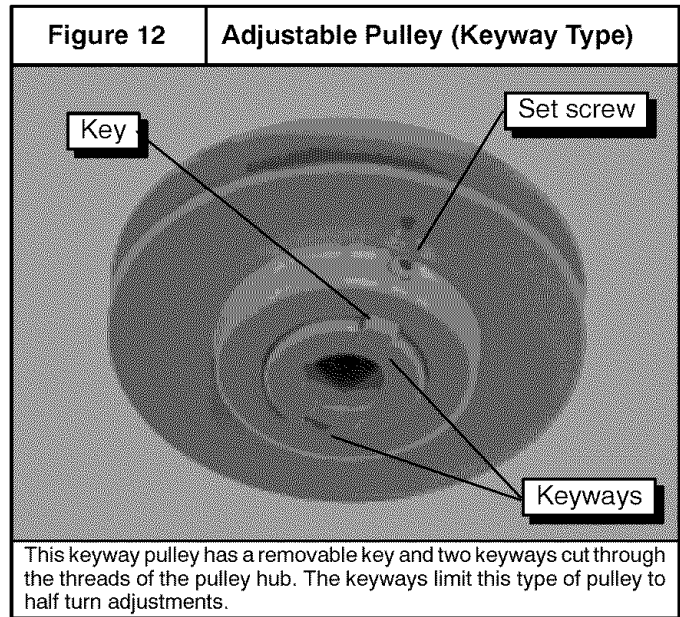

11. Remove key if unit has a keyway type pulley.
12. To set the blower for a desired CFM (L/s), first turn the outer half of the adjustable pulley clockwise until it meets the inner half of the pulley.
13. Turn the outer half of the adjustable pulley counterclockwise the correct number of turns to obtain the desired CFM (L/s).

NOTE: To increase the blower speed, turn the outer half of the adjustable pulley clockwise. To decrease the blower

speed, turn the outer half of the adjustable pulley counter-clockwise.

14. Replace key if unit has keyway type pulley.
15. Tighten set screw(s).
16. Put on belt.

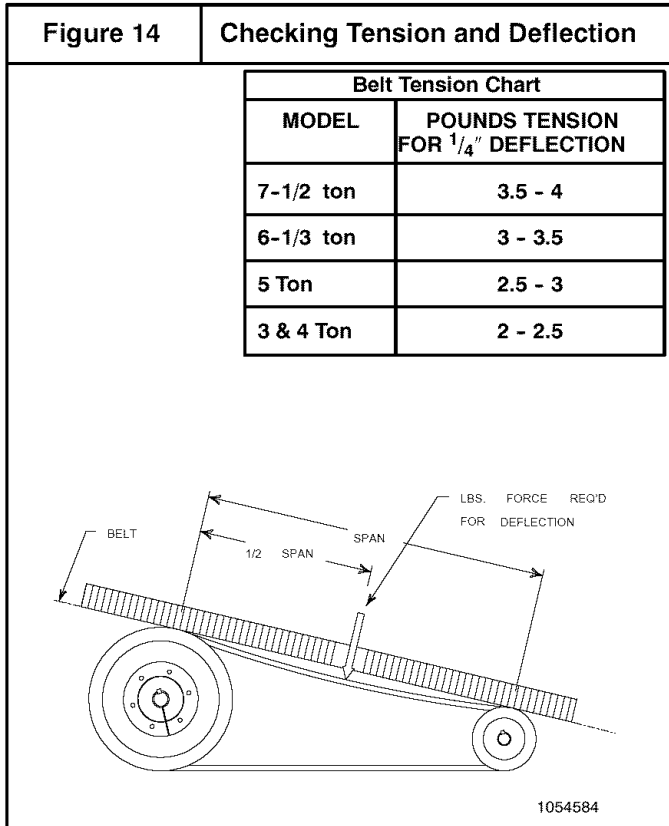

17. Turn motor adjustment bolt clockwise until the belt has enough tension at the proper deflection. Use one of the commercially available belt tension gauges to set the correct tension at the proper deflection (see **Figure 14**).

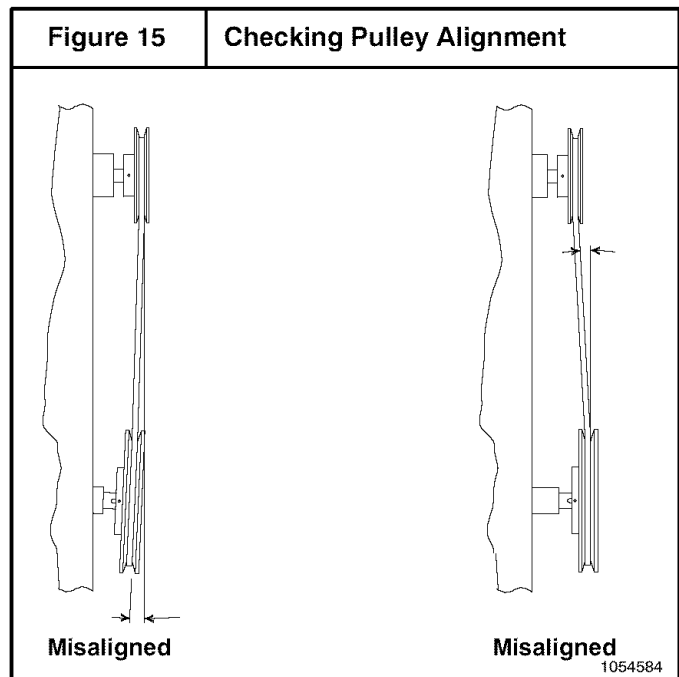

18. Use a straight-edge (angle iron, straight piece of board or anything with a good straight surface or edge) to check the alignment of the blower pulley with blower motor pulley (see **Figure 15**).

It may be necessary to back the tension off the belt temporarily and tighten one of the motor mount bolts before it is possible to adjust the angle of the blower motor.

19. Tighten all four blower motor mount bolts.

7. Economizer

The purpose of an economizer is to:

- Provide cool outside air to the conditioned space during the cooling cycle to minimize the use of the compressors.
- Bring outside air into the conditioned space to meet minimum fresh air requirements whenever the circulation blower is running.

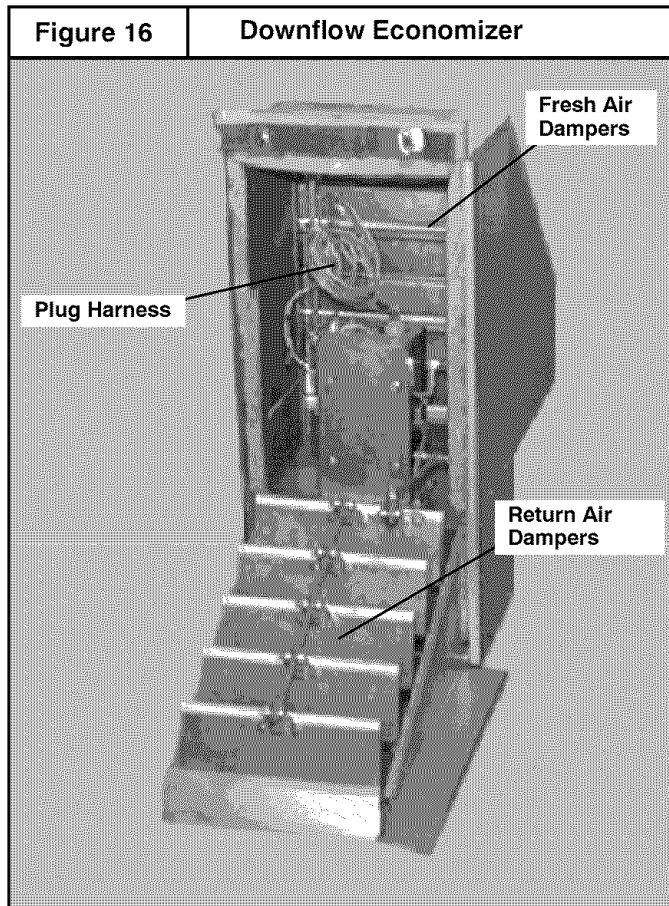

Theory of Operation

The economizer has two sets of dampers that are mechanically linked together. The fresh air dampers regulate the intake of outside air and the return air dampers regulate the flow of return air (see **Figure 16**). When the fresh air dampers modulate open, the linkage causes the return air dampers to modulate closed.

The economizer is controlled by a logic module which field connects to the unit controls through a plug harness. The logic module also controls the compressor staging based on the thermostat input.

The minimum opening position of the fresh air dampers is field adjustable. It is set on the logic module of modulating

economizers or on the actuator motor of three-position economizers.

The enthalpy sensor is factory installed on the fresh air dampers of the economizer. The enthalpy change-over point is adjustable on the logic module.

A discharge air sensor is field installed in the blower inlet. The discharge air sensor keeps the discharge air above 56°F (13.3°C).

A positive pressure is created when the fresh air dampers open and the return dampers close. This pressure must be vented or the air will not circulate properly. This is the function of the barometric relief damper. A positive pressure forces the barometric relief damper to swing open.

The fresh air dampers open to the minimum position for outside air whenever the circulation blower is **ON**.

When the thermostat is in the **FAN AUTO** position, the fresh air dampers will close completely whenever heating or cooling is not called for.

If Using a 2-Stage Thermostat

On a call for cooling, if the economizer outdoor air sensor determines that the outside air is cool enough (and in the case of an enthalpy sensor, dry enough), the fresh air dampers will modulate open and the return air dampers will modulate closed.

If the conditioned space is not being maintained at the selected temperature, the thermostat will make **Y2** and call for second stage cooling by energizing the economizer logic module at the low voltage terminal board. This energizes **Y1** and contactor which energizes the condenser fan and compressor for cooling to assist the economizer.

NOTE FOR 6-1/3 UNITS ONLY: Contactor C2 cannot be energized to operate compressor 2 while the economizer is still energized since Circuit 1 is activating the economizer and Circuit 2 is activating compressor 1.

If the thermostat is still calling for cooling and the outside air warms to above the setting for economizer operation:

- A. The economizer dampers will close to the minimum position for outside air and remain there.
- B. Contactor C1 will remain energized and compressor 1 will continue to run.
- C. Contactor C2 will close and compressor 2 will start.

If Using a Single-Stage Thermostat

When using a single stage thermostat, all steps as outlined above will be followed with the exception of the following:

The compressor will only be energized when the outside air reaches a temperature above the preset limit of the economizer. When ambient conditions are **NOT** suitable for economizer operation, **ONLY** the compressor will run, and the economizer will **NOT** be energized.

8. Start-up Procedure

WARNING

Electrical shock, fire and/or explosion hazard.

Use extreme care during all of the following checks and procedures.

Make sure Electric Power and is turned OFF as instructed in appropriate steps.

Failure to follow this warning can result in property damage, personal injury, and/or death.

Check the unit's operation as outlined in the following instructions.

Blower and Phasing Check

1. Shut **OFF** electric power at unit disconnect.
2. Check to see that clean, properly sized air filters are installed.
3. Check to see that everything inside the unit is clear and ready to operate safely. Ensure that there are no objects in, on or around the motor, belt or blower wheel.
4. Set thermostat Heat-Cool selector to **OFF**.
5. Set thermostat fan switch to **AUTO**.

WARNING

Moving parts hazard.

Do **NOT** put hands or any other object in, on or around the motor, belt or blower wheel. Ensure that there are no objects in, on or around the motor, belt or blower wheel before turning electric power on.

Failure to follow this warning can result in property damage, personal injury, and/or death.

6. Turn **ON** electric power. Nothing should start running. If any unusual arcing, odors or noises are encountered, shut **OFF** electric power immediately and check for wiring errors.

NOTE: The circulation blower motor and compressor(s) are three phase and are factory synchronized for proper rotation. *Even if the circulation blower motor comes on and air seems to be circulating, it is possible that the blower motor rotation is incorrect due to improper phasing.* The scroll compressor(s) (if equipped) will run backwards under this condi-

tion and be damaged. It is therefore necessary to check for proper rotation.

CAUTION

Do **NOT** operate the unit with the compressor(s) running until proper blower rotation has been confirmed by running the following test.

7. Set thermostat fan switch to **ON**. The circulating air blower should come **ON**.
8. Shut **OFF** electric power at unit disconnect and visually observe the direction of the blower rotation as it slows down. Do **NOT** put hands or any other object in, on or around the belt, motor or blower wheel. If blower wheel rotation is the same as the directional arrow on the blower housing, proceed to the next step.

CAUTION

If blower rotation is incorrect, shut electric power **OFF** at unit disconnect and reverse any two supply wires at field connections **ONLY**. Do **NOT** reverse the blower and/or compressor leads or rewire any internal wiring. After rewiring is done, repeat blower rotation check to ensure that blower rotation is now correct.

9. If blower rotation is correct, reset thermostat fan switch to **AUTO**. The circulating air blower should go **OFF**. Nothing should be running.
10. Shut **OFF** electric power at unit disconnect.

Cooling Checks

The compressors have a five minute anti-cycle delay that is activated whenever the compressors turn off. For instance, if the unit is manually shut off when the compressors are running and the unit is turned back on two minutes later, it will be an additional three minutes before the compressors will re-start.

CAUTION

Do **NOT** operate the unit with the compressor(s) running until proper blower rotation has been confirmed during the Blower and Phasing Check in the previous section. If the phasing is incorrect, the scroll compressor(s) (if equipped) will run backwards and they will be damaged.

1. Be sure that electric power is **OFF**.
2. To check cooling Stage 1, place jumper wires across low voltage terminal board terminals **R** to **G**, **R** to **Y1**.
3. Turn electric power **ON**. Check to see that the following occurs:
 - a. Compressor 1 - **ON**
 - b. Condenser fan motor(s) - **ON**
 - c. Circulation air blower - **ON** with correct rotation and adequate airflow from ductwork.

4. Shut **OFF** electric power at unit disconnect.
5. To check cooling Stage 2, remove jumper wires from **Y1** and place it on **Y2**.

NOTE: Allow 5 minutes between Steps 4 and 6.

6. Turn **ON** electric power. Check to see that the following occurs:
 - a. Compressors 1 & 2 - **ON**
 - b. Condenser fan motor(s) - **ON**
 - c. Circulation air blower - **ON**

NOTE: If **Y2** only is jumpered, condenser fans will not come on.

7. Shut **OFF** electric power at unit disconnect. Begin timing the five minutes for the anti-cycle delay.
8. Remove jumpers from low voltage terminal board.
9. Set Thermostat to COOL and temperature to call for Cooling.
10. Turn **ON** electric power. At the end of the five minute anti-cycle delay, the unit should start and run.
11. Shut **OFF** electric power at unit disconnect.
12. Replace all service access panels.

9. Operation And Maintenance

WARNING

Electrical shock hazard.

Turn off electric power supply at disconnect switch or service panel before removing any access or service panel from unit.

Failure to follow this warning can result in property damage, personal injury, and/or death.

Turning Off the Unit

Heating

1. Set thermostat selector to **OFF** and fan switch to **AUTO**.
2. If electric heat is running at time of shut-down, wait 2.5 minutes then shut **OFF** electric power supply at disconnect switch or service panel. (No wait is necessary if electric heat was not running within 2.5 minutes prior to shut-down.)

Cooling

1. Set thermostat selector to **OFF** and fan switch to **AUTO**.
2. To shut the unit down completely, shut **OFF** electric power supply at disconnect switch or service panel.

Starting the Unit After Shutdown

Heating

1. Set the thermostat to **OFF**.
4. Turn **ON** electric power.
5. Set thermostat to desired temperature and set selector to **HEAT**. Unit will come on and operate automatically under control of the thermostat.

Cooling

CAUTION

To prevent possible damage to the compressor(s), do NOT operate on cooling when outdoor temperature is below 35°F (2°C).

NOTE: An optional low ambient kit is available that allows the unit to operate at temperatures down to 0°F (-18°C).

1. Turn **ON** electric power.
2. Set thermostat to desired temperature and set system switch to **COOL**. The unit will come on and operate automatically under control of the thermostat.

Close all doors and windows. The unit may run continuously for several hours or longer on the initial run because of residual heat and moisture in the building. This is normal for any air conditioning system.

Thermostat Fan Switch Operation

The circulating air blower will run continuously with the fan selector switch in the **ON** position. When the fan selector switch is in the **AUTO** position, the blower will run during each heating or cooling cycle.

Adjusting Room Temperatures

If the temperature in individual rooms is not as desired, balance the system by adjusting the dampers in the branch ducts (see **Figure 16**). Adjust a little at a time and wait a day after each change to judge the effect. Once the dampers are adjusted for normal weather conditions, it is best to leave them that way. Compensate for temporary weather changes by adjusting the thermostat setting .

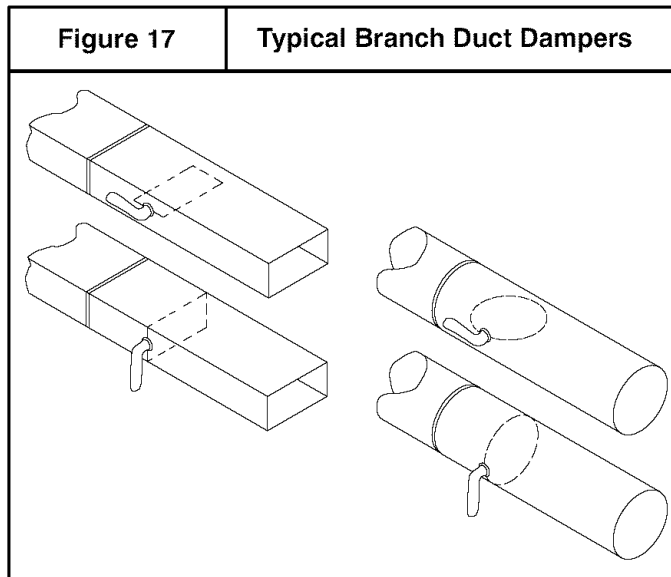

Monthly Maintenance and Inspection Checks

Air Filters (Factory Installed)

CAUTION

Do NOT operate unit without all air filters installed in the unit.

Dirty filters are the most common cause of compressor failures and inadequate heating and cooling performance.

Inspect filters at least monthly and replace or clean as required.

Washable filters may be cleaned by soaking in mild detergent and rinsing with cold water. Install filters so that the arrows on the side point in the direction of air flow.

Filter racks are accessible through the filter access panel.

Disposable Replacement Filters

To replace disposable filters:

1. Remove filter access panel.
2. Remove the bottom filters.
3. The front of the center rail is attached to the unit by a keyhole/screw connection. Unhook the front of the center rail, swing it down approximately four inches (100mm), and hook the keyhole on the screw provided.
4. Remove the bottom filters.
5. Replace bottom filters, center rail, and top filters.
6. Replace filter access panel.

Cooling Season Checks (Monthly)

Condenser Coil

Keep the condenser inlet and outlet area clean and free of leaves, grass clippings and other debris. Grass should be kept short in front of the condenser inlet. Shrubby **MUST** be trimmed back so it is no closer than 30 inches (762 mm) to condenser coil.

Condensate Drain

Check for condensate drainage. Clean as required.

Annual Maintenance and Inspection

WARNING

Electrical Shock, Fire and Explosion Hazards.

Turn off electric power supply at disconnect switch or service panel before removing any access or service panel from unit.

Failure to follow this warning can result in property damage, personal injury, and/or death.

The annual inspection should include cleaning as required to ensure efficient operation of the unit.

NOTE: All bearings are sealed and no lubrication is required.

Circulating Air Blower

Visually inspect the blower wheel for accumulations of dirt or lint. Clean the compartment and the blower wheel. If accumulation is excessive on blower wheel or does not remove easily, it will be necessary to remove the blower assembly.

RIGGING INSTRUCTIONS

⚠ WARNING

FAILURE TO FOLLOW THESE INSTRUCTIONS CAN RESULT IN PROPERTY DAMAGE, BODILY INJURY OR DEATH.

- ALL PANELS MUST BE IN PLACE WHEN RIGGING AND LIFTING.
- HOOK RIGGING SHACKLES THROUGH HOLES IN BASE RAIL, AS SHOWN IN DETAIL-A.
- USE SPREADER BARS, WHEN RIGGING, TO PREVENT UNIT DAMAGE.
- BE SURE RIGGING AND SHACKLES ARE SUFFICIENT TO HANDLE WEIGHT LISTED BELOW.

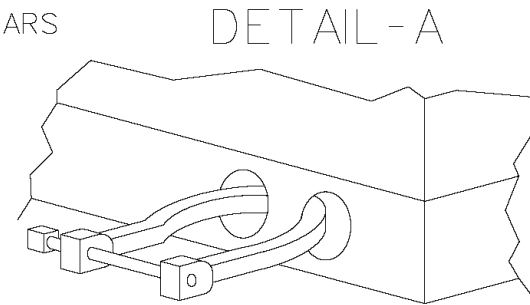
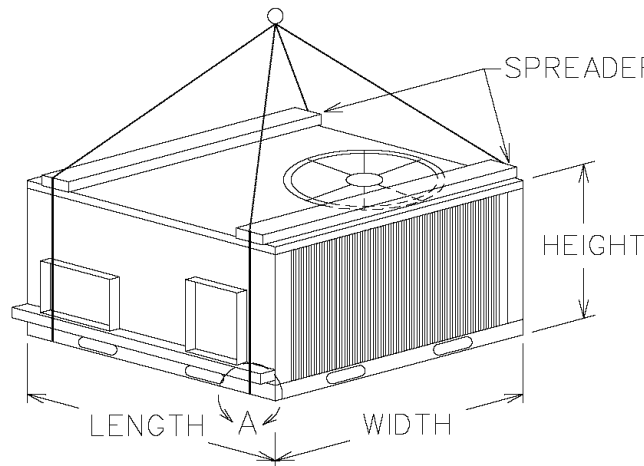

Unit Size (ton)	Weight (lbs)
3	560
3-1/2	570
4	590
5	630
6-1/3	710
7-1/2	715

INTERNATIONAL COMFORT PRODUCTS
LIMITED WARRANTY CERTIFICATE
For Cooling & Heating Products

SAVE THIS CERTIFICATE. It gives you specific legal rights, and you may also have other rights which may vary from state to state and province to province.

If your unit needs servicing, contact a qualified dealer or qualified service technician of your choice. When requesting service, please have the model and serial number from each unit in your heating and/or cooling system readily available. If your dealer needs assistance, the distributor is available to provide support and we, in turn, support its efforts.

Fill in the installation date and model and serial numbers of the unit in the space provided below and retain this Limited Warranty for your files.

GENERAL TERMS

Subject to the conditions and limitations stated herein, during the term of this Limited Warranty, we will provide a replacement for any functional component part (as defined below) of your unit found to be defective in materials or workmanship. The term of this Limited Warranty is five years from installation on Residential Products and one year from installation on Commercial Products. Except as otherwise stated in the "Additional Terms" section, this Limited Warranty covers only the original purchaser and subsequent transferees, and only while the unit remains at the site of the original installation (except for mobile home installations), and only if the unit is installed inside the continental United States, Puerto Rico, Alaska, Hawaii or Canada. In addition, the Limited Warranty applies only if the unit is installed and operated in accordance with the printed instructions accompanying the unit, and in compliance with all applicable installation and building codes and good trade practices. As used in this Limited Warranty, "installation" means the original installation of the unit.

THERE ARE EXCEPTIONS to this Limited Warranty as described on the reverse side of this page. All replacement parts will be warranted for the unused portion of the warranty coverage period on the unit. The part to be replaced must be returned by the dealer to a distributor that sells products for International Comfort Products, in exchange for the replacement part. In lieu of providing a replacement part, we may, at our sole option, refund to you an amount equal to the distributor's component purchase price from us, or provide to you a credit equal to that amount to be applied toward the purchase of any new unit that we distribute. If a credit for a new unit is given in lieu of a replacement part, the rating plate from the unit being replaced must be submitted on a warranty claim, and your dealer must make the unit being replaced available to our distributor for disposition. As a condition to warranty coverage, the unit must receive yearly maintenance, as described in the owner's manual, by a dealer. Satisfactory proof of yearly service by a dealer may be required.

"Functional component parts" include only the following: blower motor, unit-mounted sensors & timers, condenser motor, evaporator coil, condenser coil, condenser fan, capacitor, transformer, single-phase strip heat elements, expansion device, reversing valve, solenoid valve, service valve, electronic and electro-mechanical control board, ignitor, ignition module, draft inducer assembly, burner pilot, gas valve, limit control, pressure switch, relays and contactors, blower wheel, interlock switch, crosslighter, pilot shield, gas & oil burners, oil pump assembly, accumulators and factory installed driers and strainers.

This Limited Warranty **DOES NOT COVER** any labor, material, refractory chambers, oil nozzles, refrigerant, refrigerant inspection and refrigerant reclaiming, freight and/or handling charges associated with any repair or replacement and such charges will be your responsibility.

To establish the installation date for any purpose under this Limited Warranty, you must retain the original records that can establish the installation date of your unit. If you do not provide such documents the start date of the term of this Limited Warranty will be based upon the date of unit manufacture, plus thirty (30) days. In establishing that the required yearly service has occurred, you must furnish proof of yearly service by a qualified service technician.

This Limited Warranty does not cover: (a) failure or damages caused by accident, abuse, negligence, misuse, riot, fire, flood, or Acts of God (b) damages caused by operating the unit where there is a corrosive atmosphere containing chlorine, fluorine, or any other damaging chemicals (other than those found in a normal residential environment) (c) damages caused by an unauthorized alteration or repair of the unit affecting its stability or performance (d) damages caused by improper matching or application of the unit or the unit's components (e) damages caused by failing to provide proper maintenance and service to the unit in accordance with this Limited Warranty Certificate and the printed instructions originally provided with the unit (f) any expenses incurred for erecting, disconnecting, or dismantling the unit (g) parts or supplies used in connection with service or maintenance, such as refrigerant, refractory chambers, oil nozzles, filters, or belts (h) damage, repairs, inoperation or inefficiency resulting from faulty installation or application (i) electricity or fuel costs or any increase in electricity or fuel cost whatsoever including additional or unusual use of supplemental electric heat (j) units which have not had the required yearly maintenance described elsewhere in this limited warranty.

In no event shall we be liable for any incidental, consequential, or special damages or expenses in connection with any use or failure of this unit.

We have not made, do not make, and hereby disclaim any implied condition or implied warranty of fitness for a particular use or purpose, and any implied condition or implied warranty of merchantability, to the fullest extent allowed by law. We make no express or implied warranties except as stated in this Limited Warranty certificate.

No one is authorized to change this Limited Warranty or to create for us any other obligation or liability in connection with this unit. Any implied warranties shall last for the term of the expressed warranty contained herein. Some states and provinces do not allow the exclusion or limitation of incidental or consequential damages or do not allow limitations on how long an implied warranty or condition lasts, so the above limitations or exclusions may not apply to you. The provisions of this Limited Warranty are in addition to and not a modification of or subtraction from any statutory warranties and other rights and remedies provided by law.

Please refer to reverse side of this page for additional terms.

Model No. _____

Serial No. _____ Date Installed _____

Effective on units installed After July 1, 2002.

USA: International Comfort Products Corporation (USA) • 650 Heil-Quaker Avenue • P.O. Box 128 • Lewisburg, Tennessee 37091 • (931-270-4100)
CANADA: International Comfort Products division of UTC Canada Corporation • 6060 Burnside Court, Unit 1, Mississauga, Ontario L5T 2T5 (905-795-8113).

Manufacturers of Airquest, Arcoaire, Clare, Comfortmaker, Dettson, Heil, Keeprite, Lincoln, Tempstar and other quality brand name private label products.

Part No. 401 06 1010 18 (Orig. 8/9/2002)

ADDITIONAL TERMS FOR RESIDENTIAL APPLICATIONS ONLY

The Additional Terms for the components listed below are in addition to, and subject to, the General Terms on the reverse side of this page. Warranty coverage is limited to parts that fail due to defect in materials or workmanship during the specified term.

CENTRAL GAS & OIL FURNACE HEAT EXCHANGERS*

Gas Model Series: C9MPV, H9MPV, T9MPV, C9MPT, H9MPT, T9MPT, C9MPD, H9MPD, T9MPD: Limited Lifetime Warranty on heat exchangers. If a heat exchanger on one of these furnaces fails due to defect in the part, we will provide a replacement part or, at our option, credit toward the purchase of a new furnace manufactured by us. This additional Limited Warranty runs only to the original purchaser, and lasts only for as long as the original purchaser lives in the home where the furnace is initially installed.** It is not transferable to any subsequent owner. If the furnace was not installed in the home owned by the original purchaser, if the original purchaser sells the home to a subsequent owner, or if proof of original purchase cannot be provided, then the limited warranty is only for 20 years from the date of original installation.

Gas Model Series: GDL, GNL, TNE, TDE, NTC7, NDC7, NTP6, NDP6, TDE, NTV6, VNE: A replacement heat exchanger will be provided for any heat exchanger that fails in one of these furnaces due to defect for 25 years from the original date of installation.

Gas Model Series: NTC6, GNE, GDE, NDN6, NTG3, NDN3, FBF, NBF, NDF, NTN3, NTN6, NNE, N9MP1, N9MP2, FUH: A replacement heat exchanger will be provided for any heat exchanger that fails in one of these furnaces due to defect for 20 years from original date of installation.

Oil Model Series: OLR(105, 160, 182), OCF, OLF, OUF, NOLF, NOUF, OLB, OHB, ODH, FLO, MBO, LBO, NOMF: Limited Lifetime Warranty on heat exchangers. If a heat exchanger on one of these furnaces fails due to defect in the part, we will provide a replacement part or, at our option, credit toward the purchase of a new furnace manufactured by us. This additional Limited Warranty runs only to the original purchaser, and lasts only for as long as the original purchaser lives in the home where the furnace is initially installed.** It is not transferable to any subsequent owner. If the furnace was not installed in the home of the original purchaser, if the original purchaser sells the home to a subsequent owner, or if proof of original purchase cannot be provided, then the limited warranty is only for 20 years from the date of original installation.

Oil Fired Floor Furnace: NFO: A replacement heat exchanger will be provided for any heat exchanger that fails due to defect for 10 years from installation with the following limitation: during the sixth through tenth year, any credit toward your purchase of a component or toward the purchase of any new unit will be in an amount equal to the distributor's purchase price reduced by 20 percent for each year after the fifth year.

ADDITIONAL TERMS FOR OIL FURNACE APPLICATIONS ONLY

- 1) OIL BURNERS - A replacement for 5 years from date of original installation for Oil Burner Parts.
- 2) OPTIONAL ACCESSORIES AND FUNCTIONAL PARTS: A replacement for 5 years from date of original installation. (Refractory and oil nozzles not included)

GAS/ELECTRIC PACKAGED UNITS HEAT EXCHANGERS

Model series: PGAD, PGAA, PGMD, PGME, PGF, GPFM, PGC, GPCM: A replacement for 10 years from original date of installation.

COMPRESSORS:*

1) **Premium Model Units: HAC0, HAC2, HAC4, CAC0, CAC2, CAC4, KAC0, TCA0, TCA2, TCA4, HHP0, HHP2, HHP4, CHP0, CHP2, CHP4, TCH0, TCH2, TCH4, PGME, PYMC, PHAD, PGAD, PA95, PAPC, PAK, APK:** To the original purchaser a replacement for 10 years from original date of installation, only if the unit is installed with factory matched coils, except air conditioner condensing units with a nominal SEER of 10 may be matched with evaporator coils of the same nominal tonnage regardless of manufacturer and in accordance to factory recommendations. This limited 10-year warranty is not transferable to any subsequent owner. HOWEVER, if the unit was not installed in the home owned by the original purchaser, if the purchaser sells the home to a subsequent owner, or if proof of original purchase cannot be provided, then the limited warranty is only for 5 years from the original date of installation.**

2) **All Other Models: Air Conditioners, Heat Pumps, & Combination Gas/Electric Units: NAC0, NAC2, NHP0, NHP2, AO, A2, HO, H2, PGF, PGC, GPFM, GPCM, PAF, APFM, PHF, HPFM, PGAA, PGMD, PA55, PH55, PAPA, PYPA:** A replacement for 5 years from date of original installation, only if: (a) air conditioner condensing units with SEER rating in the range of 10 to 11 SEER are matched with evaporator coils of the same nominal tonnage regardless of manufacturer and in accordance to factory recommendations, or (b) heat pump condensing units are used with factory matched coils, unless written approval to do otherwise is obtained from manufacturer.

ADDITIONAL TERMS FOR COMMERCIAL APPLICATIONS ONLY

For purposes of this warranty a commercial application is one in which: the product has over 5 tons nominal cooling capacity, or is designed for operation with 3 phase electrical power, or is installed in a commercial establishment such as a beauty or hair salon, hospital, school, restaurant, church, hotel etc..

3-Phase Models: PGF, GPFM, GPF, PGAD, PGME, PGB, PGMG, PGMF, PGS, PGE, APE, PAE, PAB, PAMD, PAS, PAF, APFM, APF, PHB, PHE, PYMD, HPB, PHS, CAC, ACC, CAE, ACE, CHC, HCC, CHE, HCE:

The additional Terms of the components listed below are in addition to and subject to the General Terms on the reverse side of this page.

- 1) **GAS FIRED HEAT EXCHANGERS (ALL MODELS):*** A replacement for 10 years from date of original installation.
- 2) **COMPRESSORS (ALL MODELS):*** A replacement for 5 years from date of original installation.
- 3) **OPTIONAL ACCESSORIES AND FUNCTIONAL COMPONENT PARTS (ALL MODELS):***
A replacement for 1 year from date of original installation.
- 4) **COMMERCIAL OIL MODELS: OLR210, OLR350, OTF210, AMT3, AMT4, AMP3:** Ten(10) Year Limited Warranty on heat exchangers.
*To receive advantage of your limited warranty, you must provide proof of yearly service by a qualified service technician.
**To receive advantage of your warranty, you must retain the original records that can establish the installation date and proof of purchase of the unit.

MINI SPLITS:

Summary - Mini Splits Warranted for one (1) year on all replacement parts.

Additional terms for Mini Splits:

The additional Terms of the components listed below are in addition to, and subject to, the General Terms on the reverse side of this page.

1) **Compressors (All Models):** A replacement compressor will be provided for all compressors that fail due to defect for 5 years from date of original installation.

2) **Optional Accessories and Functional Components Parts (All Models):**
A replacement part will be provided for all parts that fail due to defect for one (1) year from date of original installation.

Failure to maintain the equipment through annual maintenance by a qualified service technician shall void the warranty. Proof of service will be required with all warranty claims. Proof of purchase and installation date must be submitted with all claims.