

Owner's Manual

Built-In
36" Single Door
Refrigerators
and
36" Single Door
Freezers



Monogram®

Introduction

Your new Monogram refrigerator/freezer makes an eloquent statement of style, convenience and kitchen planning flexibility. Whether you chose it for its purity of design, practical storage arrangements or assiduous attention to detail—or for all of these reasons—you'll find that your Monogram refrigerator/freezer's superior blend of form and function will delight you for years to come.

The Monogram refrigerator/freezer was designed to provide the flexibility to blend in with your kitchen cabinetry. Decorative door insert panels allow it to match your kitchen cabinets or blend with your kitchen decor. Custom handles are also available to further personalize your refrigerator/freezer. Through a series of product and trim kit choices, the Monogram refrigerator/freezer can be beautifully integrated into the kitchen.

Since this is designed to be a built-in product, custom panels are required on the front of the Monogram refrigerator/freezer. Consult your kitchen designer or cabinetmaker for your customized look.

The information on the following pages will help you operate and maintain your refrigerator/freezer properly.

If you have any other questions, visit our Website at: www.monogram.com.

Contents

Consumer Services

Important Phone Numbers	19
Model and Serial Numbers	3
Problem Solver	16, 17
Product Registration	3
Safety Instructions	4-7
Warranty	Back Cover

Care and Cleaning

Cleaning—Outside and Inside	13
Condenser	13
Light Bulb Replacement	14
Vacation	14

Operating Instructions

Automatic Icemaker	9
Shelves	11, 12
Storage Drawers	10
Temperature Controls	8
Water Filter Accessory	9
Wine Rack	11

Preparation

Clearances	15
Leveling	15
Location	15

Before using your refrigerator/freezer

Read this manual carefully. It is intended to help you operate and maintain your new refrigerator/freezer properly.

Keep it handy for answers to your questions.

If you don't understand something or need more help, there is a list of toll-free consumer service numbers included in the back section of this manual.

OR

Visit our Website at: www.monogram.com

*Write
down the
model &
serial
numbers*

You'll see them on a label inside the refrigerator/freezer under the storage drawers.

These numbers are also on the Consumer Product Ownership Registration Card included with this manual.

Before sending in this card, please write these numbers here:

Model Number

Serial Number

Use these numbers in any correspondence or service calls concerning your refrigerator/freezer.

*If you
received a
damaged
refrigerator/
freezer*

The warranty does not cover damage caused after delivery.

Immediately contact the dealer (or builder) that sold you the refrigerator/freezer.

*Save time
& money*

Before you request service, check the Problem Solver in the back of this manual.

It lists causes of minor operating problems that you can correct yourself.

*If you
need
service*

To obtain service, see the Consumer Services page in the back of this manual.

We're proud of our service and want you to be pleased. If for some reason you are not happy with the service you receive, here are steps to follow for further help.

For customers in the USA:

FIRST, contact the people who serviced your appliance. Explain why you are not pleased. In most cases, this will solve the problem.

NEXT, if you are still not pleased, write all the details—including your phone number—to:

Manager, Customer Relations
GE Appliances
Appliance Park
Louisville, KY 40225

For customers in Canada:

FIRST, contact the people who serviced your appliance. Explain why you are not pleased. In most cases, this will solve the problem.

NEXT, if you are still not pleased, write all the details—including your phone number to:

Manager, Consumer Relations
Camco Inc.
1 Factory Lane, Suite 310
Moncton, N.B. E1C 9M3

IMPORTANT SAFETY INSTRUCTIONS

READ AND SAVE THESE INSTRUCTIONS

WARNING—When using this appliance, always exercise basic safety precautions, including the following:

- **Use this appliance only for its intended purpose** as described in this Owner's Manual.
- **This refrigerator/freezer must be properly installed in accordance with the Installation Instructions before it is used.**
- **Do not allow children to climb, stand or hang on the shelves in the refrigerator/freezer.** They could damage the refrigerator/freezer and seriously injure themselves.
- **Do not touch the cold surfaces in the freezer compartment when hands are damp or wet.** Skin may adhere to these extremely cold surfaces.
- **Do not store or use gasoline or other flammable vapors and liquids in the vicinity of this or any other appliance.**
- **If your freezer has an automatic icemaker,** avoid contact with the moving parts of the ejector mechanism, or with the heating element located on the bottom of the icemaker. Do not place fingers or hands on the automatic icemaking mechanism while the refrigerator/freezer is plugged in.
- **Unplug your refrigerator/freezer before cleaning and making repairs.** **NOTE:** We strongly recommend that any servicing be performed by a qualified individual.
- **Before replacing a burned-out light bulb,** the refrigerator/freezer should be unplugged in order to avoid contact with a live wire filament. (A burned-out light bulb may break when being replaced.) **NOTE:** Turning control to OFF does not remove power to the light circuit.
- **Do not refreeze frozen foods which have thawed completely.**

⚠ DANGER: RISK OF CHILD ENTRAPMENT

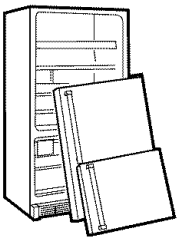

Child entrapment and suffocation are not problems of the past. Junked or abandoned refrigerator/freezers are still dangerous...even if they will sit for "just a few days." If you are getting rid of your old refrigerator/freezer, please follow the instructions below to help prevent accidents.

Before You Throw Away Your Old Refrigerator/Freezer or Freezer:

- Take off the doors.
- Leave the shelves in place so that children may not easily climb inside.

REFRIGERANTS

All refrigeration products contain refrigerants, which under federal law must be removed prior to product disposal. If you are getting rid of an old refrigeration product, check with the company handling the disposal about what to do.

LIRE ET CONSERVER CES INSTRUCTIONS

AVERTISSEMENT :

Lorsque vous utilisez le réfrigérateur/congélateur, observez toujours certaines précautions de base, notamment :

- **N'utilisez l'appareil que pour son usage prévu**, comme décrit dans le présent manuel de l'utilisateur.
- **Installez le réfrigérateur/congélateur conformément aux directives d'installation avant de l'utiliser.**
- **Ne laissez pas les enfants grimper, s'asseoir, se tenir debout ni se pendre aux clayettes du réfrigérateur/congélateur.** Ils pourraient endommager le réfrigérateur et se blesser gravement.
- **Une fois le congélateur en marche, ne touchez pas les surfaces froides du congélateur, surtout si vous avez les mains humides ou mouillées :** la peau risque d'adhérer à ces surfaces très froides.
- **N'entreposez et n'utilisez pas d'essence ou autres vapeurs et liquides inflammables à proximité de cet appareil ou de tout autre appareil électroménager.**
- **Pour les réfrigérateurs doté d'une machine à glaçons automatique**, évitez le contact avec les pièces mobiles du mécanisme éjecteur ou avec l'élément chauffant situé à la partie inférieure de la machine à glaçons. Ne posez pas les doigts ou les mains sur le mécanisme de la machine à glaçons pendant que le réfrigérateur/congélateur est branché.
- **Débranchez votre réfrigérateur/congélateur avant de le nettoyer et de le réparer.**
REMARQUE : Nous vous recommandons vivement de confier toute réparation à un technicien qualifié.
- **Avant de remplacer une ampoule grillée**, le réfrigérateur/congélateur doit être débranché afin d'éviter tout contact avec un fil sous tension. (Une ampoule grillée peut se briser pendant l'opération). **REMARQUE :** Lorsque vous placez la commande sur «0» (éteint), l'alimentation électrique de l'ampoule n'est pas coupée.
- **Ne faites PAS recongeler des aliments surgelés qui ont complètement dégelé.**

⚠ DANGER : RISQUES POUR LES ENFANTS

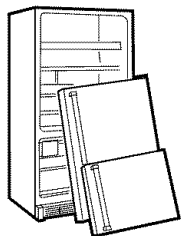

Les enfants pris au piège ou morts d'asphyxie sont toujours d'actualité. Les appareils de réfrigération abandonnés sont toujours aussi dangereux, même si on n'attend que "quelque jours" pour s'en débarrasser. Si vous ne gardez pas votre ancien appareil, veuillez suivre les directives ci-dessous afin de prévenir les accidents.

Avant de vous débarrasser de votre vieux appareil de réfrigération :

- Démontez les portes.
- Laissez les clayettes en place afin d'empêcher les enfants de grimper à l'intérieur.

RÉFRIGÉRANTS

Tous les appareils de réfrigération contiennent des réfrigérants qui, conformément aux lois fédérales, doivent être enlevés avant toute élimination de l'appareil. Si vous vous débarrassez de vieux appareils de réfrigération, vérifiez, auprès de la société qui s'occupe de leur élimination, ce que vous devez faire.

IMPORTANT SAFETY INSTRUCTIONS

HOW TO CONNECT ELECTRICITY

Do not, under any circumstances, cut or remove the third (ground) prong from the power cord. For personal safety, this appliance must be properly grounded.

The power cord of this appliance is equipped with a 3-prong (grounding) plug which mates with a standard 3-prong (grounding) wall outlet to minimize the possibility of electric shock hazard from this appliance.

Have the wall outlet and circuit checked by a qualified electrician to make sure the outlet is properly grounded.

Where a standard 2-prong wall outlet is encountered, it is your personal responsibility and obligation to have it replaced with a properly grounded 3-prong wall outlet.

The refrigerator/freezer should always be plugged into its own individual electrical outlet which has a voltage rating that matches the rating plate.

DO NOT USE AN ADAPTER PLUG TO CONNECT THE REFRIGERATOR/FREEZER TO A 2-PRONG OUTLET.

DO NOT USE AN EXTENSION CORD WITH THIS APPLIANCE.

This provides the best performance and also prevents overloading house wiring circuits which could cause a fire hazard from overheated wires.

Never unplug your refrigerator/freezer by pulling on the power cord. Always grip plug firmly and pull straight out from the outlet.

Repair or replace immediately all power cords that have become frayed or otherwise damaged. Do not use a cord that shows cracks or abrasion damage along its length or at either end.

When moving the refrigerator/freezer away from the wall, be careful not to roll over or damage the power cord.

SAVE THESE INSTRUCTIONS

RACCORDEMENT ÉLECTRIQUE

Ne coupez ni retirez en aucun cas la troisième broche (mise à la terre) de la fiche du cordon d'alimentation. Pour votre sécurité, cet appareil doit être correctement mis à la terre.

Le cordon d'alimentation de cet appareil est muni d'une fiche à 3 broches (mise à la terre) qui se branche dans une prise mural ordinaire à 3 alvéoles (mise à la terre) pour réduire au minimum les risques du chocs électriques.

Faites examiner la prise de courant et le circuit par un électricien qualifié pour vous assurer que la prise est correctement mise à la terre.

Si la prise murale est du type standard à 2 alvéoles, il vous incombe de la faire remplacer par une prise à 3 alvéoles correctement mise à la terre.

Le réfrigérateur/congélateur doit toujours être branché dans sa propre prise de courant, dont la tension nominale est identique à celle indiquée sur la plaque signalétique.

**N'UTILISEZ PAS UNE FICHE
D'ADAPTATION POUR RACCORDER
LE RÉFRIGÉRATEUR/CONGÉLATEUR
DANS UNE PRISE MURALE À 2 ALVÉOLES.**

**N'UTILISEZ PAS DE CORDONS
PROLONGATEURS AVEC CET APPAREIL.**

Cette précaution est recommandée pour garantir un rendement optimum et éviter une surcharge des circuits électriques de la résidence, ce qui pourrait créer un risque d'incendie par surschauffe des fils.

Ne débranchez jamais l'appareil en tirant le cordon d'alimentation. Saisissez fermement la fiche du cordon et tirez droit pour la retirer de la prise.

Réparez ou remplacez immédiatement tout cordon effiloché ou endommagé. N'utilisez pas un cordon fendillé ou présentant des signes d'usure.

Lorsque vous déplacez l'appareil du mur, faites attention de ne pas la faire rouler sur le cordon d'alimentation afin de ne pas l'endommager.

CONSERVEZ CES DIRECTIVES

Operating Instructions

Refrigerator/Freezer

Set the temperature control

WHEN YOU FIRST TURN THE REFRIGERATOR/FREEZER ON, SET THE CONTROL AT 5.

9 is the coldest setting, 1 is the warmest.

For colder or warmer temperatures, adjust the control one number at a time.

IMPORTANT: When first setting the control, or adjusting it, allow 24 hours for the refrigerator/freezer to get cold.

NOTE: Turning the control to the OFF position stops cooling in the refrigerator/freezer, but does not shut off power to the refrigerator/freezer.



How to test temperatures

Use the milk test for the refrigerator. Place a container of milk on the top shelf. Check it a day later. If the milk is too warm or too cold, adjust the temperature control.

Use the ice cream test for the freezer. Place a container of ice cream in the center of the freezer. Check it after a day. If it's too hard or too soft, adjust the temperature control.

Always allow 24 hours for the refrigerator/freezer to reach the temperature you set.

Automatic Icemaker (freezer models)

Refrigerator/Freezer

Automatic icemaker (freezer models)

A newly-installed freezer may take 12–24 hours to begin making ice.

The icemaker will produce seven cubes per cycle—approximately 100–130 cubes in a 24-hour period, depending on the freezer temperature, room temperature, number of door openings and other use conditions.

If your freezer is operated before the water connection is made to the icemaker, set the power switch to **O (off)**.

When the freezer has been connected to the water supply, set the power switch to **I (on)**. The green light will come on.

The icemaker will fill with water when it cools to 15°F. A newly-installed freezer may take 12–24 hours to begin making ice cubes.

Throw away the first few batches of ice to allow the water line to clear.

Be sure nothing interferes with the sweep of the feeler arm.

When the bin fills to the level of the feeler arm, the icemaker will stop producing ice.

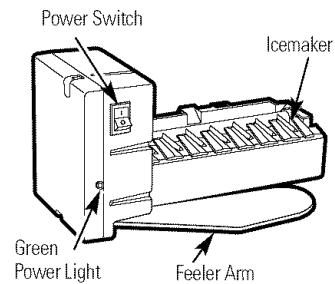

It is normal for several cubes to be joined together.

If ice is not used frequently, old ice cubes will become cloudy, taste stale and shrink.

If ice cubes get stuck in the icemaker, the green power light will blink. To correct this, set the power switch to **O (off)** and remove the cubes. Set the power switch to **I (on)** to restart the icemaker.

After the icemaker has been turned on again, there will be a delay of about 45 minutes before the icemaker resumes operations.

NOTE: In homes with lower-than-average water pressure, you may hear the icemaker cycle multiple times when making one batch of ice.

Water filter accessory

The water filter is an option at extra cost and is available from your dealer, GE Parts and Accessories, 800.626.2002 or GEAppliances.com. Specify your choice of either GXRLQ or GXITQ. Both have complete installation instructions and install on 1/4" O.D. water line.

Both water filters require replacement cartridges. Replacement cartridges are available through GE Parts and Accessories, 800.626.2002, or GEAppliances.com.

Model No.	Replacement Cartridge No.
GXRLQ	GXRTQR
GXITQ	GXITQR

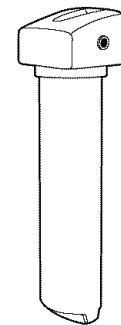

In-Line Refrigerator/Icemaker Filter
Model #GXRLQ

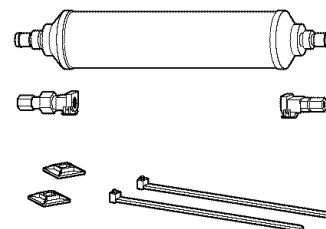

Refrigerator Water Filter Kit
Model #GXITQ

Storage Drawers

Refrigerator/Freezer

Refrigerator— Storage drawers

The upper drawers have individual, adjustable humidity controls that let you control the amount of cold air entering the drawers.

Slide the control all the way to the High setting and the drawer provides **higher humidity levels** recommended for most leafy vegetables.

Slide the control all the way to the Low setting and the drawer provides **lower humidity levels** recommended for most fruits.

Excess water that may accumulate in the bottom of the drawers should be emptied and the drawers wiped dry.

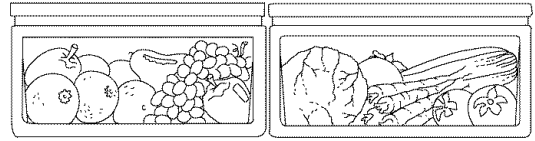

Refrigerator— Sealed snack pans

The sealed snack pans retain high humidity for the convenient storage of lunch meats and cheese, hors d'oeuvres, spreads and snacks.

To remove a snack pan, pull the pan out and lift the front of the pan up until it snaps out of the wire holder.

To replace a snack pan, place the back of the pan in the wire holder. Lower the front of the pan, then push down until the front of the pan snaps into the wire holder.

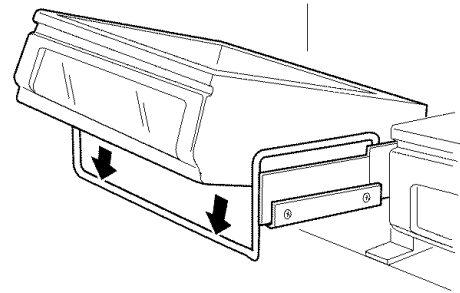
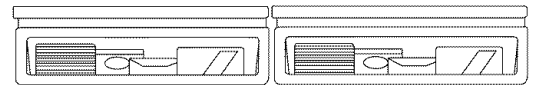

Drawer removal

Drawers in the refrigerator/freezer will stop before coming all the way out, to help prevent contents from spilling onto floor.

To remove a drawer, pull the drawer out and lift the front of the drawer up and out of the wire holder. Lift the back of the drawer up and out.

To remove the upper drawers when the door cannot be opened fully, the shelf above the drawers must be removed. Push the shelf back, then lift up. Tilt the cover and take it out.

To replace a drawer, place the back of the drawer in the wire holder, making sure the extensions of the side of the drawer fit into the back of the wire holder. Lower the front of the drawer into the wire holder. Press firmly on the top of the drawer.

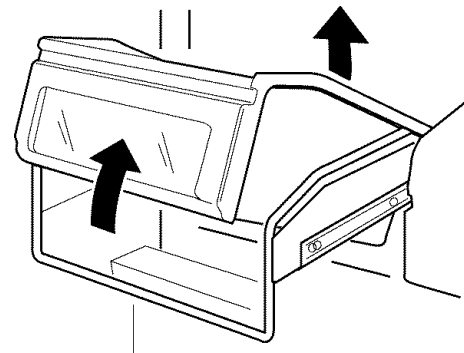

Adjustable shelves

Tempered glass shelves in the refrigerator and wire shelves in the freezer enable you to make efficient shelf arrangements to fit your family's food storage needs.

To remove shelves: Tilt shelf up at front, then lift it up and out of tracks on rear wall of refrigerator/freezer.

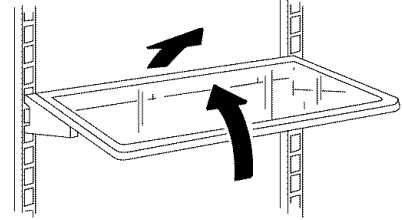

To replace shelves: Select desired shelf height. With shelf front raised slightly, engage top lugs in tracks at rear of cabinet. Then lower front of shelf until it locks into position.

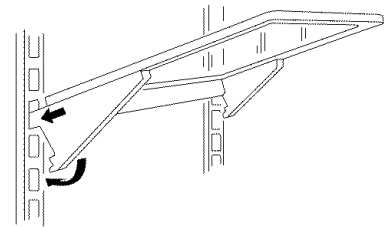

Removable wine rack (on all refrigerator models)

The wine rack is designed to hold a bottle on its side and will fit on any shelf.

To relocate the wine rack: Pull the wine rack straight out, position its lip over the right edge of the shelf you want to suspend it from and push it all the way in.

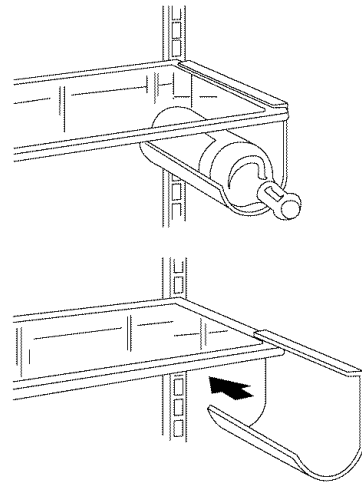

Door shelves

Some door shelves are adjustable and can be moved up and down to meet your storage needs. The deeper door shelves must be placed at the bottom of the door.

To remove: Lift the shelf up and slide it towards you.

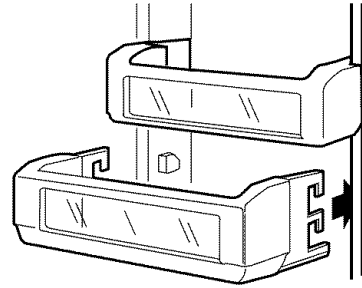

Care and Cleaning

Refrigerator/Freezer

Cleaning outside

Door handles and trim—Clean with a cloth dampened with soapy water. Dry with a soft cloth.

Keep the outside clean. Wipe with a clean cloth lightly dampened with mild liquid dish detergent. Dry with a clean, soft cloth.

Do not wipe the refrigerator with a soiled dish cloth or wet towel. These may leave a residue that can damage the finish. Do not use scouring pads, powdered cleaners, bleach or cleaners containing bleach because these products can scratch and damage the finish.

Stainless steel—Regularly clean and polish the Stainless Steel Door Panels and Handles (on some models) with a commercially available stainless steel cleaner such as *Stainless Steel Magic™* to preserve and protect the fine finish. *Stainless Steel Magic* is available through GE Parts and Accessories, 800.626.2002, or GEAppliances.com. Order part number WX10X15.

Do not use appliance wax or polish on the stainless steel.

Cleaning inside

To help prevent odors, leave an open box of baking soda in the refrigerator/freezer.



Turn off power at the circuit breaker or fuse box before cleaning. If this is not practical, wring excess moisture out of sponge or cloth when cleaning around switches, lights or controls.

Use warm water and baking soda solution—about a tablespoon (15 ml) of baking soda to a quart (1 liter) of water. This both cleans and neutralizes odors. Thoroughly rinse and wipe dry.

Other parts of the refrigerator/freezer—including door gaskets, meat and vegetable drawers, ice storage bin and all plastic parts—can be cleaned the same way. After cleaning the door gaskets, apply a thin layer of petroleum jelly to the door gaskets at the hinge side. This helps keep the gaskets from sticking and bending out of shape.

Avoid cleaning cold glass shelves with hot water because the extreme temperature difference may cause them to break. Handle glass shelves carefully. Rough handling of tempered glass can cause it to shatter.

Do not wash any plastic refrigerator/freezer parts in the dishwasher.

Condenser

To clean the condenser fins:

First turn off the power at the circuit breaker or fuse box. Wait about 30 minutes for the condenser area to cool. Then remove the decorative panel by lifting up and toward you.

Use a soft bristle brush to loosen dust and lint on the condenser fins. Use a vacuum hose to remove soil.

After cleaning: Reconnect power at the fuse box or circuit breaker.

Replace the decorative panel.

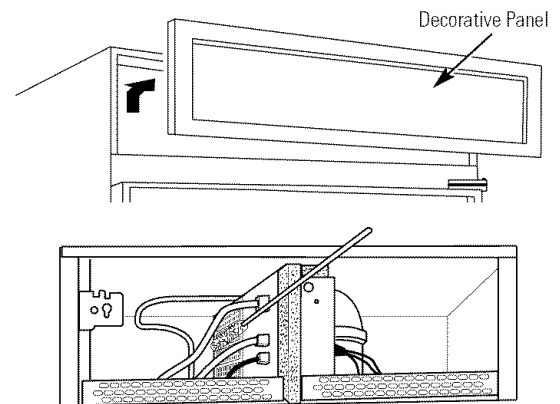

Care and Cleaning

Refrigerator/Freezer

Preparing for vacation

For long vacations or absences, remove food and unplug the refrigerator/freezer. Move the control to OFF, and clean the interior with a baking soda solution of one tablespoon (15 ml) of baking soda to one quart (1 liter) of water. Leave the doors open.

For shorter vacations, remove perishable foods and leave the control at the regular setting. However, if the room temperature is expected to drop below 60°F (16°C), follow the same instructions as for extended vacations.

Move icemaker power switch to the **O (off)** position and shut off the water supply to the refrigerator/freezer.

Upper light bulb replacement

Turning the control to OFF does not remove power to the light circuit.

There are light bulbs at the top of the refrigerator/freezer.

To replace a bulb:

- 1 Turn off power at the circuit breaker or fuse box.
- 2 Grasp the back of the shield with both hands, pull the light shield forward and rotate down. This will release the tabs at the back of the shield from the back wall of the refrigerator. Next, move the shield back to release the tabs at the front of the shield.
- 3 Replace with the same size bulb and reinstall the shield.
- 4 Turn the power on.

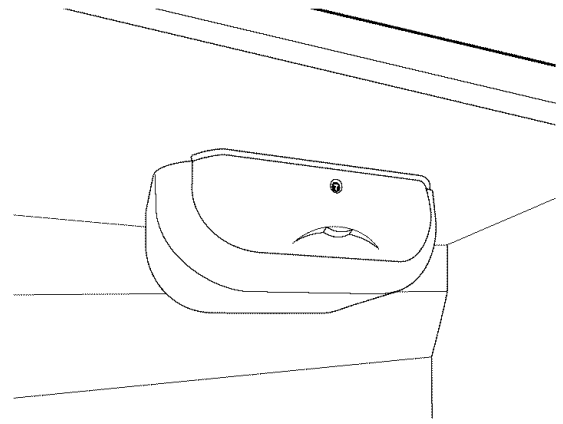

Lower light bulb replacement

To replace a bulb:

- 1 Turn off power at the circuit breaker or fuse box.
- 2 Remove the top two drawers.
- 3 Replace with the same size bulb, reinstall the drawers and turn the power on.

Preparation

Refrigerator/Freezer

Refrigerator/ freezer location

Do not install the refrigerator/freezer where temperatures will be below 60°F (16°C) because it will not run often enough to maintain proper temperatures, and the refrigerator will develop high internal humidity.

For proper installation, the refrigerator/freezer must be placed on a level surface of hard material the same height as the rest of the flooring. This surface should be strong enough to support a fully loaded refrigerator/freezer, or approximately 1,200 lbs. each. See the Installation Instructions (Pub. No. 49-60073-3) for complete directions.

Clearances

If the refrigerator/freezer is to be installed in a corner, a 4" clearance is required on the hinge side for a 90° door opening and access to fresh food drawers. A 15" clearance is required on the hinge side to remove pans. A 25" clearance is required on the hinge side for a full 130° door swing.

No other clearances at top, sides or back are required. See the Installation Instructions (Pub. No. 49-60073-3) for complete directions.

Leveling

These products have a 4-point leveling system. The front is supported by leveling legs, the rear is supported by wheels.

- Adjust rear wheels beneath the product to just barely touch the 2x4 block.
- Turn the 7/16" hex nut located above the front wheels. Turn to raise or lower.
- For front leveling legs, use a 1-1/4" open-end wrench.
- Adjust carefully; the product should be level and plumb with cabinetry, and should align with toekick height.

⚠ CAUTION—The rear leveling wheels and front leveling legs are limited to a maximum height adjustment of 1". If the installation requires more than 84-1/2" height, the installer should elevate the refrigerator on a sheet of plywood or runners. Cabinetry trim could also be added across the top of the opening to shorten the opening. **If you attempt to raise the refrigerator more than 1", you will damage the front leveling legs and rear leveling wheels.**

See the Installation Instructions (Pub. No. 49-60073-3) for complete directions.

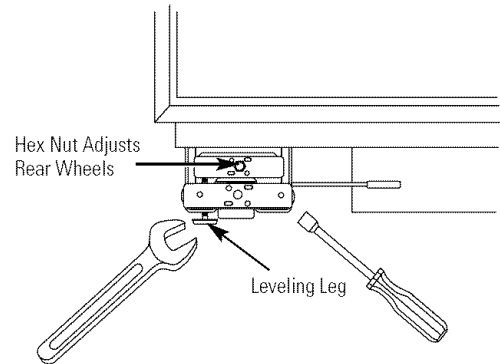

⚠ MISE EN GARDE—

Les roues de nivellement arrière et les pattes de nivellement avant permettent un réglage maximal de 25 mm (1 po). Si l'ouverture pour le réfrigérateur a une hauteur supérieure à 2,15 m (84-1/2 po), l'installateur doit élever le réfrigérateur sur une feuille de contre-plaqué ou des glissières. Il est également possible d'ajouter des baguettes de finition des placards sur le haut de l'ouverture afin de la réduire. **Lever le réfrigérateur de plus de 25 mm (1 po) endommage les pattes de nivellement avant et les roues de nivellement arrière.**

The Problem Solver

Refrigerator/Freezer

*Questions?
Use this
problem
solver!*

PROBLEM	POSSIBLE CAUSE
REFRIGERATOR/ FREEZER DOES NOT OPERATE	<ul style="list-style-type: none"> • May be in defrost cycle when motor does not operate for about 30 minutes. • Temperature control in the OFF position. • If interior light is not on, refrigerator/freezer may not be plugged in at wall outlet. • The fuse is blown/circuit breaker is tripped. Replace fuse or reset the breaker.
MOTOR OPERATES FOR LONG PERIODS OR CYCLES ON AND OFF FREQUENTLY (Modern refrigerators and freezers with more storage space and a larger freezer require more operating time. They start and stop often to maintain even temperatures.)	<ul style="list-style-type: none"> • Normal when refrigerator/freezer is first plugged in. Wait 24 hours or the refrigerator/freezer to completely cool down. • Often occurs when large amounts of food are placed in refrigerator/freezer. This is normal. • Door left open or package holding door open. • Hot weather or frequent door openings. This is normal. • Temperature control set at the coldest setting. See Temperature Control. • Condenser needs cleaning. See Care and Cleaning.
VIBRATION OR RATTLING (Slight vibration is normal.)	<ul style="list-style-type: none"> • See Leveling.
OPERATING SOUNDS	<ul style="list-style-type: none"> • The high speed compressor motor required to maintain near zero temperatures in the large freezer may produce higher sound levels than your old refrigerator/freezer. • Normal fan air flow—one fan blows cold air through refrigerator/freezer—another fan cools the compressor motor. • These NORMAL sounds will also be heard from time to time: <ul style="list-style-type: none"> • Defrost timer switch clicks at defrost. • Defrost water dripping. • Temperature control clicks ON or OFF. • Refrigerant boiling or gurgling. • Cracking or popping of cooling coils caused by expansion and contraction during defrost and refrigeration following defrost. • Ice cubes dropping into the bin and water running in pipes as icemaker refills.
DOOR NOT CLOSING PROPERLY	<ul style="list-style-type: none"> • Refrigerator/freezer not level. See Leveling.
REFRIGERATOR/ FREEZER TOO WARM	<ul style="list-style-type: none"> • Temperature control not set cold enough. See Temperature Control. • Warm weather or frequent door openings. • Door left open for long time. • Package may be holding door open.

*Questions?
Use this
problem
solver!*

PROBLEM	POSSIBLE CAUSE
FROST OR ICE CRYSTALS ON FROZEN FOOD (Frost within package is normal.)	<ul style="list-style-type: none"> • Door left open or package holding door open. • Too frequent or too long door openings.
SLOW ICE CUBE FREEZING	<ul style="list-style-type: none"> • Door may have been left open. • Turn temperature control to a colder setting.
ICE CUBES HAVE ODOR/TASTE	<ul style="list-style-type: none"> • Old cubes need to be discarded. • Ice storage bin needs to be emptied and washed. • Unsealed packages in freezer may be transmitting odor/taste to ice cubes. • Interior of freezer needs cleaning. See Care and Cleaning. • Poor-tasting incoming water. Install a water filter.
AUTOMATIC ICEMAKER DOES NOT WORK	<ul style="list-style-type: none"> • Icemaker power switch is in the O (off) position. • Water supply turned off or not connected. • Freezer too warm. • Piled up cubes in storage bin may cause icemaker to shut off too soon. Level cubes by hand.
MOISTURE FORMS ON OUTSIDE OF REFRIGERATOR/FREEZER	<ul style="list-style-type: none"> • Not unusual during periods of high humidity. Wipe surface dry.
MOISTURE COLLECTS INSIDE	<ul style="list-style-type: none"> • Too frequent or too long door openings. • In humid weather, air carries moisture into refrigerator/freezer when doors are opened.
REFRIGERATOR/FREEZER HAS ODOR	<ul style="list-style-type: none"> • Foods with strong odors should be tightly covered. • Check for spoiled food. • Interior needs cleaning. See Care and Cleaning. • Defrost water system needs cleaning. • Keep open box of baking soda in refrigerator/freezer; replace every 3 months.
INTERIOR LIGHT DOES NOT WORK	<ul style="list-style-type: none"> • No power at outlet. • Light bulb needs replacing. See Care and Cleaning.

With the purchase of your new Monogram appliance, receive the assurance that if you ever need information or assistance from GE, we'll be there. All you have to do is call—toll-free!

GE Answer Center®

**In the USA:
800.626.2000**

Whatever your question about any Monogram major appliance, GE Answer Center® information service is available to help. Your call—and your question—will be answered promptly and courteously. And you can call any time. GE Answer Center® service is open 24 hours a day, 7 days a week.

In Canada, call 888.880.3030.

OR

Visit our Website at: www.monogram.com

In-Home Repair Service

**In the USA:
800.444.1845**

**In Canada:
888.880.3030**

A GE consumer service professional will provide expert repair service, scheduled at a time that's convenient for you. Many GE Consumer Service company-operated locations offer you service today or tomorrow, or at your convenience (7:00 a.m. to 7:00 p.m. weekdays, 9:00 a.m. to 2:00 p.m. Saturdays). Our factory-trained technicians know your appliance inside and out—so most repairs can be handled in just one visit.

For Customers With Special Needs...

**In the USA:
800.626.2000**

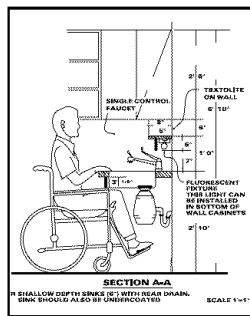

GE offers Braille controls for a variety of GE appliances, and a brochure to assist in planning a barrier-free kitchen for persons with limited mobility.

Consumers with impaired hearing or speech who have access to a TDD or a conventional teletypewriter may call 800.TDD.GEAC (800.833.4322) to request information or service.

Service Contracts

**In the USA:
800.626.2224**

**In Canada:
888.880.3030**

You can have the secure feeling that GE Consumer Service will still be there after your warranty expires. Purchase a GE contract while your warranty is still in effect and you'll receive a substantial discount. With a multiple-year contract, you're assured of future service at today's prices.

Parts and Accessories

**In the USA:
800.626.2002**

**In Canada:
888.880.3030**

Individuals qualified to service their own appliances can have parts or accessories sent directly to their home. The GE parts system provides access to over 47,000 parts...and all GE Genuine Renewal Parts are fully warranted. VISA, MasterCard and Discover cards are accepted.

User maintenance instructions contained in this manual cover procedures intended to be performed by any user. Other servicing generally should be referred to qualified service personnel. Caution must be exercised, since improper servicing may cause unsafe operation.

YOUR MONOGRAM WARRANTY

Staple sales slip or cancelled check here. Proof of original purchase date is needed to obtain service under warranty.

WHAT IS COVERED

From the Date of the Original Purchase

FULL TWO-YEAR WARRANTY

For two years from date of original purchase, we will provide, free of charge, parts and service labor in your home to repair or replace *any part of the refrigerator/freezer* that fails because of a manufacturing defect.

FULL FIVE-YEAR WARRANTY

For five years from date of original purchase, we will provide, free of charge, parts and service labor in your home to repair or replace *any part of the sealed refrigerating system* (the compressor, condenser, evaporator and all connecting tubing) that fails because of a manufacturing defect.

LIMITED ADDITIONAL SEVEN-YEAR WARRANTY ON THE SEALED SYSTEM

For the sixth through twelfth year from the date of the original purchase, we will provide, free of charge, replacement parts for *any part of the sealed refrigerating system* (the compressor, condenser, evaporator and all connecting tubing) that fails because of a manufacturing defect. You pay for the service trip to your home and for service labor charges.

LIMITED LIFETIME WARRANTY ON FULL EXTENSION SLIDES

From the date of the original purchase we will provide, free of charge, replacement parts for *any part of the full extension slides* that fails because of a manufacturing defect. You pay for the service trip to your home and for service labor charges.

.....
This warranty is extended to the original purchaser and any succeeding owner for products purchased for ordinary home use in the 48 mainland states, Hawaii and Washington, D.C. In Alaska the warranty is the same except that it is LIMITED because you must pay to ship the product to the service shop or for the service technician's travel costs to your home.

All warranty service will be provided by our Factory Service Centers or by our authorized Customer Care® servicers during normal working hours.

Should your appliance need service, during warranty period or beyond, in the U.S.A. call 800.444.1845. In Canada: 888.444.1845.

WHAT IS NOT COVERED

- Service trips to your home to teach you how to use the product.
- Replacement of house fuses or resetting of circuit breakers.
- Incidental or consequential damage caused by possible defects with this appliance.
- Damage to the product caused by accident, fire, floods or acts of God.
- Damage caused after delivery.
- Failure of the product if it is used for other than its intended purpose or used commercially.
- Improper installation, delivery or maintenance. If you have an installation problem, contact your dealer or installer. You are responsible for providing adequate electrical, plumbing and other connecting facilities.
- Loss of food due to spoilage.
- Replacement of the light bulbs other than as noted above.

Some states/provinces do not allow the exclusion or limitation of incidental or consequential damages, so the above limitation or exclusion may not apply to you. This warranty gives you specific legal rights, and you may also have other rights which vary from state to state/province to province. To know what your legal rights are in your state/province, consult your local or state/provincial consumer affairs office or your state's/province's Attorney General.

Warrantor in USA: General Electric Company.
Louisville, KY 40225

Warrantor in Canada: Camco Inc.



Monogram®

162D9646P003
49-60317-1

GE Consumer Products
General Electric Company
Louisville, KY 40225

©2003 General Electric Company