

Digital Video Camcorder

Mini DV Digital Video Cassette

SC-D6550

- AF** Auto Focus
- CCD** Charge Coupled Device
- LCD** Liquid Crystal Display

Owner's Instruction Book

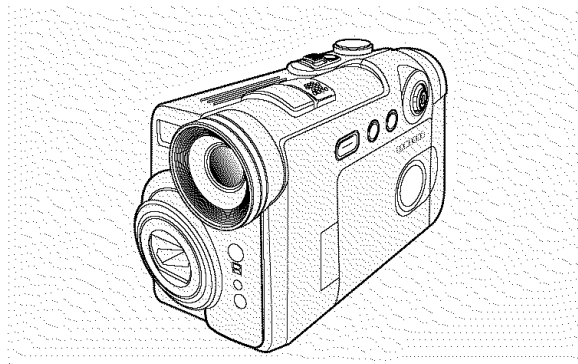

Before operating the unit, please read this Instruction Book thoroughly, and retain it for future reference.



US PATENT 4415844

Notices and Safety Instructions

Safety Instructions

	CAUTION RISK OF ELECTRIC SHOCK DO NOT OPEN	
CAUTION: TO REDUCE THE RISK OF ELECTRIC SHOCK, DO NOT REMOVE COVER (OR BACK). NO USER SERVICEABLE PARTS INSIDE. REFER SERVICING TO QUALIFIED SERVICE PERSONNEL.		

To prevent electric shock, match wide blade of plug to wide slot and fully insert.



This symbol is intended to alert the user to the presence of uninsulated dangerous voltage within the product's enclosure that may be of sufficient magnitude to constitute a risk of fire or electric shock.



This symbol is intended to alert the user to the presence of important operating and maintenance instructions in the literature accompanying this product.

1. READ INSTRUCTIONS:

All the safety and operating instructions should be read before the CAMCORDER is operated.

2. RETAIN INSTRUCTIONS:

The safety and operating instructions should be retained for future reference.

3. HEED WARNINGS:

All warnings on the CAMCORDER and in the operating instructions should be adhered to.

4. FOLLOW INSTRUCTIONS:

All operating and maintenance instructions should be followed.

5. CLEANING:

Unplug this CAMCORDER from the wall outlet before cleaning. Do not use liquid or aerosol cleaners. Use a dry cloth used for dusting cabinets.

6. ATTACHMENTS:

Do not use attachments not recommended by the CAMCORDER product manufacturer as they may be hazardous.

7. WATER AND MOISTURE:

Do not use this CAMCORDER near water; for example, near a bathtub, wash bowl, kitchen sink, laundry tub, in a wet basement, near a swimming pool or lake.

8. ACCESSORIES:

Do not place this CAMCORDER on an unstable cart, stand, tripod, bracket or table. The CAMCORDER may fall, causing serious injury to a child or an adult, and serious damage to the unit. Use only with a cart, stand, tripod, bracket, or table recommended by the manufacturer or sold with the CAMCORDER. Any mounting of the unit should follow the manufacturer's instructions and should use a mounting accessory recommended by the manufacturer.

A. An appliance and cart combination should be moved with care. Quick stops, excessive force and uneven surfaces may cause the appliance and cart combination to overturn.
PORTABLE CART WARNING
(Symbol provided by RETAC)



Notices and Safety Instructions

9. VENTILATION:

Slots and openings in the cabinet are provided for ventilation to ensure reliable operation of the CAMCORDER and to protect it from overheating. These openings must not be blocked or covered. Never place your CAMCORDER on a bed, sofa, rug, or other similar surface: on or near a radiator or heat register. This CAMCORDER should not be placed in a built-in installation such as a bookcase or rack unless proper ventilation is provided or the manufacturer's instructions have been adhered to.

10. POWER SOURCES:

The CAMCORDER should be operated only from the type of power source indicated on the label.

If you are not sure of the type of power supply at your home, consult your appliance dealer or local power company.

A CAMCORDER is intended to be operated from battery power, or other sources, refer to the operating instructions.

11. GROUNDING OR POLARIZATION:

This CAMCORDER may be equipped with either a polarized 2-wire AC line plug (a plug having one blade wider than the other) or a 3-wire grounding type plug, a plug having a third (grounding) pin.

If you are unable to insert the plug fully into the outlet, try reversing the plug. If the plug still fails to fit, contact your electrician to replace your outlet. Do not defeat the safety purpose of the polarized plug.

12. POWER-CORD PROTECTION:

Power-supply cords should be routed so that they are not likely to be walked on or pinched by items placed upon or against them, paying particular attention to cords or plugs, convenient receptacles, and the point where they exit from the unit.

13. OUTDOOR ANTENNA GROUNDING:

If an outside antenna or cable system is connected to the CAMCORDER, be sure the antenna or cable system is grounded to provide some protection against voltage surges and built-up static charges, Section 810 of the National Electrical Code, ANSI/NFPA No. 70-1984, provides information with respect to proper grounding of the mast and supporting structure, grounding of the lead-in wire and supporting structure, grounding of the mast and supporting structure, grounding of the lead-in wire to an antenna discharge unit, size of grounding to conductors, location of antenna-discharge unit, connection to grounding electrodes and requirements for the grounding electrode. See figure below.

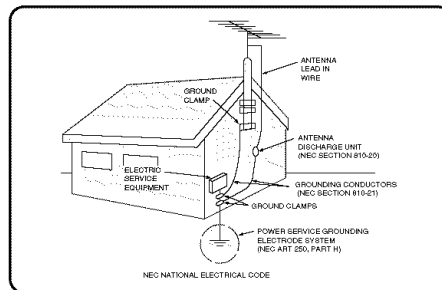

Notices and Safety Instructions

14. LIGHTNING:

For added protection of this CAMCORDER during a lightning storm or when it is left unattended and unused for long periods of time, unplug it from the wall outlet and disconnect the antenna or cable system.

This will prevent damage to the CAMCORDER due to lightning and power-line surges.

15. POWER LINES:

An outside antenna system should not be located in the vicinity of overhead power lines or other electric light or power circuits where it can fall into such power lines or circuits. When installing an outside antenna system, extreme care should be taken to keep from touching such power lines or circuits as contact with them might be fatal.

16. OVERLOADING:

Do not overload wall outlets and extension cords as this can result in a risk of fire or electric shock.

17. OBJECTS AND LIQUIDS:

Never push objects of any kind into this CAMCORDER through openings as they may touch dangerous voltage points or short out a part that could result in a fire or electric shock.

Never spill liquids of any kind onto the CAMCORDER. Should spillage occur, unplug unit and have it checked by a technician before use.

18. SERVICING:

Do not attempt to service this CAMCORDER yourself. Opening or removing covers may expose you to dangerous voltage or other hazards.

Refer all servicing to qualified service personnel.

19. DAMAGE REQUIRING SERVICE:

Unplug this CAMCORDER from the wall outlet and refer servicing to qualified service personnel under the following conditions:

- a. When the power-supply cord or plug is damaged.
- b. If any liquid has been spilled onto, or objects have fallen into the CAMCORDER.
- c. If the CAMCORDER has been exposed to rain or water.
- d. If the CAMCORDER does not operate normally by following the operating instructions, adjust only those controls that are covered by the operating instructions. Improper adjustment of other controls may result in damage and will often require extensive work by a qualified technician to restore the CAMCORDER to its normal operation.
- e. If the CAMCORDER has been dropped or the cabinet has been damaged.
- f. When the CAMCORDER exhibits a distinct change in performance, this indicates a need for service.

20. REPLACEMENT PARTS:

When replacement parts are required, be sure the service technician has used replacement parts specified by the manufacturer and having the same characteristics as the original part.

Unauthorized substitutions may result in fire, electric shock or other hazards.

21. SAFETY CHECK:

Upon completion of any service or repairs to this CAMCORDER, ask the service technician to perform safety checks to determine that the CAMCORDER is in safe operating order.

Notices and Safety Instructions

22. To prevent damage which may result in fire or shock hazard, do not expose this appliance to rain or moisture.
23. If this power supply is used at 240V ac, a suitable plug adapter should be used.

NOTE TO CATV SYSTEM INSTALLER:

This reminder is provided to call the CATV system installer's attention to Article 820-40 of the NEC that provides guidelines for proper grounding and, in particular, specifies that the cable ground shall be connected to the grounding system of the building as close to the point of cable entry as practical.

USER INSTALLER CAUTION:

Your authority to operate this FCC certified equipment could be voided if you make changes or modifications not expressly approved by this party responsible for compliance to part 15 FCC rules.

NOTE:

(Hg) LAMP(S) INSIDE THIS PRODUCT CONTAIN MERCURY AND MUST BE RECYCLED OR DISPOSED OF ACCORDING TO LOCAL, STATE OR FEDERAL LAWS. For details see lamprecycle.org, eiae.org, or call 1-800-Samsung

NOTE: This equipment has been tested and found to comply with the limits for a Class B digital device, pursuant to part 15 of the FCC Rules. These limits are designed to provide reasonable protection against harmful interference in a residential installation. This equipment generates, uses and can radiate radio frequency energy and, if not installed and used in accordance with the instructions, may cause harmful interference to radio communications. However, there is no guarantee that interference will not occur in a particular installation. If this equipment does cause harmful interference to radio or television reception, which can be determined by turning the equipment off and on, the user is encouraged to try to correct the interference by one or more of the following measures:

- Reorient or relocate the receiving antenna.
- Increase the separation between the equipment and receiver.
- Connect the equipment into an outlet on a circuit different from that to which the receiver is connected.
- Consult the dealer or an experienced radio/TV technician for help and for additional suggestions.

The user may find the following booklet prepared by the Federal Communications Commission helpful: "How to Identify and Resolve Radio-TV Interference Problems."

This Booklet is available from the U.S. Government Printing Office, Washington, D.C. 20402, Stock No. 004-000-00345-4.

FCC Warning

The user is cautioned that changes or modifications not expressly approved by the manufacturer could void the user's authority to operate the equipment.



FCC ID : A3L05GAMMA3

This device complies with Part 15 of FCC Rules.

Operation is subject to the following two conditions;

- (1) This device may not cause harmful interference
- (2) This device must accept any interference received, including interference that may cause undesired operation.

Contents

Notes and Safety Instructions	8
Getting to Know Your Camcorder	13
Features	13
Accessories Supplied with Camcorder	14
Front & Left View	15
Left Side View	16
Right & Top View	17
Rear & Bottom View	18
Remote Control	19
Preparation	20
Adjusting the Hand Strap	20
Hand Strap	20
Shoulder Strap	20
Attaching the Lens Cover	20
Lithium Battery Installation	21
Battery Installation for the Internal Clock	21
Battery Installation for the Remote Control	21
Connecting a Power Source	22
To use the AC Power Adapter and DC Cable	22
Using the Lithium Ion Battery Pack	23
Charging the Lithium Ion Battery Pack	23
Table of continuous Recording Time based on Model and Battery Type	24
Battery Level Display	25
Turning the OSD (On Screen Display) On/Off	25
OSD (On Screen Display) in REC/PLAY Modes	26
OSD (On Screen Display) in  (Program)/  (Play) Modes	27
Using the Joystick	28
The Camcorder : System Menu Setting	29
Selecting the OSD Language	29
Setting the Clock	30
Setting the Wireless Remote Control Acceptance (Remote)	31
Setting the Beep Sound	32
Viewing the Demonstration	33

Contents

<i>The Camcorder : Display Menu Setting.....</i>	<i>34</i>
Adjusting the LCD Screen.....	34
Displaying the Date/Time	35
Setting the TV Display.....	36
<i>The Camcorder : Basic Recording</i>	<i>37</i>
Using the Viewfinder	37
Adjusting the Focus.....	37
Inserting and Ejecting a Cassette.....	38
Hints for Stable Image Recording.....	39
Recording with the LCD Screen	39
Recording with the Viewfinder.....	39
Various Recording Techniques.....	40
Making your First Recording	41
Using EASY.Q Mode (for Beginners).....	42
Record Search.....	43
Setting the Zero Memory	44
Self Record using the Remote Control	45
Zooming In and Out	46
Using the Tele Macro.....	46
Using the Fade In and Out.....	47
To Start Recording.....	47
To Stop Recording (use Fade In/Fade Out)	47
Using Back Light Compensation Mode (BLC).....	48
Using the Color Nite	49
<i>The Camcorder : Advanced Recording.....</i>	<i>50</i>
Use of various Functions.....	50
Setting Menu Items	50
Function availability in each Mode.....	51
Selecting the Record Mode.....	52
Selecting Audio Mode.....	53
Cutting Off Wind Noise (Wind Cut)	54
Setting the Shutter Speed & Exposure.....	55
Recommended Shutter Speeds when Recording	55
Auto Focus/Manual Focus	56
Auto Focusing.....	56
Manual Focusing.....	56

Contents

Setting the White Balance.....	57
Using Quick Menu: White Balance	58
Setting the Digital Image Stabilizer (DIS)	59
Using Quick Menu: Digital Image Stabilizer (DIS)	60
Programmed Automatic Exposure Modes (Program AE).....	61
Setting the Program AE.....	62
Using Quick Menu: Program AE	62
Applying Digital Effects.....	63
Selecting the Digital Effects	64
Using Quick Menu: Digital Effects.....	65
Zooming In and Out with Digital Zoom	66
Selecting the Digital Zoom	66
Photo Image Recording	67
Searching for a Photo Image	67

***The Camcorder : Playback* 68**

Playing Back a Tape You have recorded on the LCD Screen	68
Adjusting the LCD Bright/Color during Playback.....	68
Controlling Sound from the Speaker.....	69
Tape Playback	70
Playback on the LCD Screen.....	70
Playback on a TV Monitor.....	70
Connecting to a TV which has Audio/Video Input Jacks	70
Connecting to a TV which has no Audio and Video Input Jacks	71
Playback	71
Various Functions in PLAY Mode.....	72
Playback Pause.....	72
Picture Search (Forward/Reverse)	72
Slow Playback (Forward/Reverse)	72
Frame Advance (To play back frame by frame)	73
X2 Playback (Forward/Reverse)	73
Reverse Playback.....	73
Audio Dubbing	74
Dubbing Sound.....	74
Dubbed Audio Playback	75

***IEEE 1394 Data Transfer* 76**

***USB Interface* 78**

Contents

<i>Digital Still Camera Mode : Preparation</i>	82
Using the Mode Dial	82
Using the Memory Card	82
Memory Card Functions	82
Inserting a Memory Card	83
Ejecting a Memory Card	83
Number of Recordable Images/Time Length of Moving Image	84
<i>Digital Still Camera Mode : Functions</i>	85
Numbering Stored Pictures	85
Setting the Image Quality	86
Setting the Image Size	87
Setting the Menu Language	88
Setting the LCD Brightness	89
Setting the Clock	90
Setting the IMPRINT Option	91
Setting the Wireless Remote Control Acceptance (WL.REMOTE)	92
Setting the Beep Sound	93
Setting the Shutter Sound	93
Use of various Functions	94
<i>Digital Still Camera Mode : Basic Image Taking</i>	97
Taking and Viewing Your First Photo	97
Taking Still Images	97
Taking Still Images: EASY.Q Mode	97
Viewing Still Images	98
Viewing a Single Still Image	98
Viewing a Slide Show	99
Setting the Q.View Duration	100
Viewing a Still Image using the Quick Review	100
Viewing Multiple Images in Multiple Image View	101
Deleting Still Images and Moving Images	101
Deleting One Image in Multiple Image View	101
Deleting Image Using DELETE Menu	102
Delayed Recording – Self Timer	103
MPEG Recording	104
Setting the Resolution and Frame Rate	104
Recording a Moving Image onto a Memory Card	105

Contents

MPEG Playback	106
To Playback a Recorded Moving Image	106
<i>Digital Still Camera Mode : Advanced Techniques 107</i>	
Setting the Focus	107
Using the Built-In Flash	108
Available Flash Modes by Camera Mode	109
Setting the Focus Modes	110
Auto Focus Mode	110
Manual Focus Mode	110
Continuous Auto Focus Mode	111
Macro Mode	112
Setting the Exposure	113
Locking the Auto Exposure: AE LOCK	113
Setting the Auto Exposure Metering Options: SPOT AE or MULTI AE	114
SCENE Modes – Preset Auto Exposure Modes	115
Manual Exposure Compensation	116
Setting the Aperture	117
Setting the Shutter Speed	118
Setting the White Balance	119
Setting the Preset White Balance	119
Setting the Manual White Balance	120
Setting the ISO Sensitivity	121
Using Digital Special Effects	122
Taking Multiple Images Using Auto Exposure Bracketing	123
Taking Multiple Images using Continuous Shot	124
Setting the Sharpness	125
Using the Digital Zoom	126
Zooming In	126
Zooming Out	126
Rotating a Stored Image	127
Resizing a Stored Image	128
Customizing Your Camera – MySET Menu	129
Memorizing Your Current Settings	129
Loading Your Customized Settings	130
Customizing Your Camera – Changing the Start-Up Image	131
Zooming & Trimming Recorded Images (Playback ZOOM) While Viewing	132
Zooming the Image	132
Trimming the Image	132

Contents

Protecting Stored Images.....	133
Formatting a Memory Card.....	135
Printing Your Images – Using the PictBridge™.....	136
Connecting To a Printer.....	136
Selecting Images.....	137
Customizing Print Options.....	138
Printing Images.....	139
Printing Images Using DPOF (Digital Print Order Format) Settings.....	140
Resetting PictBridge Settings.....	140
Printing Your Images – Using the DPOF (Digital Print Order Format).....	141
Standard DPOF Setup.....	141
Index DPOF Setup.....	142
Print Size DPOF Setup.....	142
Printing DPOF Marked Images.....	143
Maintenance.....	144
Cleaning and Maintaining the Camcorder.....	144
After Using Your Camcorder.....	144
Cleaning For LCD Screen.....	144
Cleaning the Camera Body and Video Heads.....	145
Using Your Camcorder Abroad.....	146
Power Sources.....	146
Color System.....	146
Troubleshooting.....	147
Specifications.....	150
Index.....	152
Warranty(SEA users only).....	154

Notes and Safety Instructions

Notes regarding the Rotation of the LCD Screen

Please rotate the LCD screen carefully as illustrated. Over rotation may cause damage to the inside of the hinge that connects the LCD screen to the Camcorder.

1. LCD screen closed.
2. Standard recording using the LCD screen.
 - Open the LCD screen with your finger.
3. Recording when looking at the LCD screen from the top.
4. Recording when looking at the LCD screen from the front.
5. Recording when looking at the LCD screen from the left.
6. Recording with the LCD screen closed.

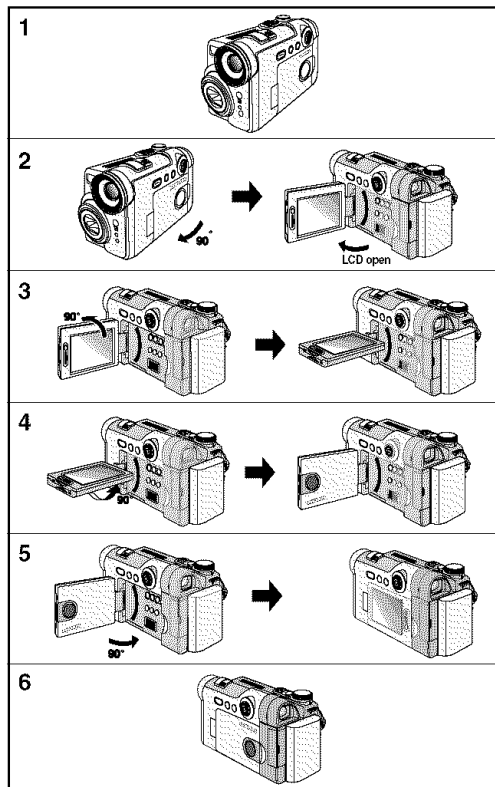

Notes and Safety Instructions

Notices regarding Copyright

Television programs, video tapes, DVD titles, films, and other program materials may be copyrighted.

Unauthorized copying of copyrighted material may be against the law.

All the trade names and registered trademarks mentioned in this manual or other documentation provided with your Samsung product are trademarks or registered trademarks of their respective holders.

Notes regarding Moisture Condensation

1. A sudden rise in atmospheric temperature may cause condensation to form inside the Camcorder.

for example:

- When you move the Camcorder from a cold location to a warm location (e.g. from outside to inside during the winter.)
- When you move the Camcorder from a cool location to a hot location (e.g. from inside to outside during the summer.)

2. If the  (DEW) protection feature is activated, leave the Camcorder for at least two hours in a dry, warm room with the cassette compartment opened and the Battery pack removed.

Notes regarding Camcorder

1. Do not leave the Camcorder exposed to high temperatures (above 60°C or 140°F).

For example, in a parked car in the sun or exposed to direct sunlight.

2. Do not let the Camcorder get wet.

Keep the Camcorder away from rain, sea water, and any other form of moisture.

If the Camcorder gets wet, it may get damaged.

Sometimes a malfunction due to exposure to liquids cannot be repaired.

Notes and Safety Instructions

Notes regarding the Battery Pack

- Be sure to use a recommended battery pack as described on page 24. The batteries are available at a SAMSUNG retailer.
 - Make sure that the Battery pack is fully charged before starting to record.
 - To preserve battery power, keep your Camcorder turned off when you are not operating it.
 - If your Camcorder is in REC mode, and it is left in STBY mode without being operated for more than 5 minutes with a tape inserted, it will automatically turn itself off to protect against unnecessary battery discharge.
 - Make sure that the Battery pack is fitted firmly into place.
Do not drop the Battery pack. Dropping the Battery pack may damage it.
 - A brand new Battery pack is not charged.
Before using the Battery pack, you need to charge it completely.
 - Fully discharging a Lithium-Ion battery damages the internal cells. The Battery pack may be prone to leakage when fully discharged.
 - To avoid damage to the battery pack, make sure to remove the battery when no charge remains.
 - It is a good idea to use the viewfinder rather than the LCD screen when recording for long periods, because the LCD screen consumes more battery power.
- When the battery reaches the end of its life, please contact your local dealer.
The batteries have to be dealt with as chemical waste.
- Be careful not to drop the battery pack when you release it from the camcorder.

Notes regarding the Video Head Cleaning

- To ensure normal recording and a clear picture, clean the video heads regularly.
If a square block-shape distorts playback, or only a blue screen is displayed, the video heads may be dirty.
If this happens, clean the video heads with a dry type cleaning cassette.
- Do not use a wet-type cleaning cassette. It may damage the video heads.

Notes and Safety Instructions

Note regarding the Lens

Do not film with the camera lens pointing directly at the sun.
Direct sunlight can damage the CCD (Charge Coupled Device).

Notes regarding electronic Viewfinder

1. Do not position the Camcorder such that the Viewfinder is pointing towards the sun.
Direct sunlight can damage the inside of the Viewfinder. Be careful when placing the Camcorder under sunlight or near a window exposed to sunlight.
2. Do not pick up the Camcorder by holding the Viewfinder.
3. Applying excessive force to the Viewfinder may damage it.

Notes regarding 'Record' or 'Playback' Using the LCD Screen

1. The LCD screen has been manufactured using high precision technology. However, there may be tiny dots (red, blue or green in color) that appear on the LCD screen. These dots are normal and do not affect the recorded picture in any way.
2. When you use the LCD screen under direct sunlight or outdoors, it may be difficult to see the picture clearly.
If this occurs, we recommend using the Viewfinder.
3. Direct sunlight can damage the LCD screen.

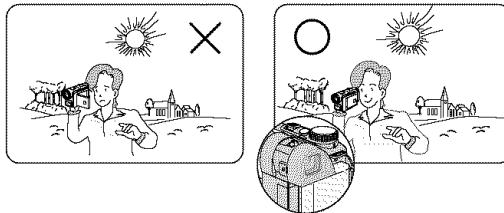

Notes regarding the Hand Strap

- To ensure a steady picture while filming, check that the hand strap is properly adjusted.
- Do not force your hand into the hand strap as you could damage it.

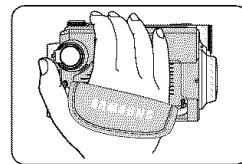

Notes and Safety Instructions

Precaution regarding the Lithium Battery

1. The Lithium battery maintains the clock function and user settings; even if the Battery pack or AC adapter is removed.
2. The Lithium battery for the Camcorder lasts about 6 months under normal operation from time of installation.
3. When the Lithium battery becomes weak or dead, the date/time indicator will display **12:00 AM JAN. 1, 2005** when you set the Date/Time to on.
When this occurs, replace the Lithium battery with a new one(type CR2025).
4. There is a danger of explosion if battery is incorrectly replaced.
Replace only with the same or equivalent type.

Warning: Keep the Lithium battery out of reach of children. Should a battery be swallowed, consult a doctor immediately.

Servicing

- Do not attempt to service this Camcorder yourself.
- Opening or removing covers may expose you to dangerous voltage or other hazards.
- Refer all servicing to qualified service personnel.

Replacement Parts

- When replacement parts are required, be sure the service technician has used replacement parts specified by the manufacturer and having the same characteristics as the original part.
- Unauthorized substitutions may result in fire, electric shock or other hazards.

[CAUTION]

- DO NOT FIRE THE FLASH WHILE SCREENING THE FLASH BY HANDS. DO NOT TOUCH THE FLASHLIGHT AFTER CONTINUOUS FIRING OF THE FLASH. POSSIBLE BURNING HAZARD.

[WARNING]

- DO NOT FIRE THE FLASH FROM A SHORT DISTANCE TO A PERSON TO A PERSON(ESPECIALLY TOWARDS AN INFANT.)CLOSE FIRING A FLASH MIGHT CAUSE SERIOUS DAMAGE TO ONE'S EYES.

Getting to Know Your Camcorder

Features

■ **Multi OSD Language**

You can select the desired OSD language from OSD List.

■ **Digital Data Transfer Function with IEEE1394**

By incorporating the IEEE 1394 (i.LINK™; i.LINK is a serial data transfer protocol and interconnectivity system, used to transmit DV data) high speed data transport port, both moving and still images can be transferred to a PC, making it possible to produce or edit various images.

■ **USB Interface for Digital Image Data Transfer**

You can transfer images to a PC using the USB interface without an add-on card.

■ **Integrated Camcorder/Digital Still Camera operation**

An integrated digital imaging device that easily converts between a Digital Camcorder and a Digital Still Camera with a flip of the Power Switch, ensuring comfortable and easy recording.

■ **900x Digital Zoom**

Allows you to magnify an image up to 900x (Camcorder Mode) or 12x (Camera Mode) its original size.

■ **Color TFT LCD**

A high-resolution color TFT LCD gives you clean, sharp images as well as the ability to review your recordings immediately.

■ **Digital Image Stabilizer (DIS)**

The DIS compensates for any handshake, reducing unstable images particularly at high magnification.

■ **Various Digital Effects (DSE)**

The DSE (Digital Special Effects) allows you to give your films a special look by adding various special effects.

■ **Back Light Compensation (BLC)**

The BLC function compensates for the bright background behind a subject you're recording.

■ **Program AE**

The program AE enables you to alter the shutter speed and aperture to suit the type of scene/action to be filmed.

■ **Digital Still Camera Function**

- Using Memory card, you can easily record and playback standard still images.
- You can transfer standard still images on the Memory card to your PC using the USB interface.

■ **MPEG Recording**

MPEG recording makes it possible to record video onto a Memory card.

■ **Multi Memory Card Slot**

Multi Memory card slot is able to use Memory Stick, Memory Stick PRO, MMC and SD.

■ **High Resolution Image Quality (Digital Still Camera)**

Employing 5 Mega Pixels CCD, a maximum resolution of 2592x1944 is available.

■ **Supports DPOF & PictBridge Printing Aid**

DPOF (Digital Printing Order Format) and PictBridge interfaces are supported. By using these features, you can print your still images by using a printer that supports these features without having to use your PC.

Getting to Know Your Camcorder

Accessories Supplied with Camcorder

✦ Make sure that the following basic accessories are supplied with your digital camcorder.

Basic Accessories

1. Lithium Ion Battery Pack
2. AC Power Adapter (AA-E8 TYPE)
3. AC Cord
4. Multi-AV Cable (Audio/Video/S-Video Cable)
5. Instruction Book
6. Lithium Batteries for Remote Control or Clock. (TYPE: CR2025)
7. Remote Control
8. USB Cable
9. Software CD
10. Shoulder Strap
11. Lens Cover
12. Lens Cover Strap



Getting to Know Your Camcorder

Front & Left View

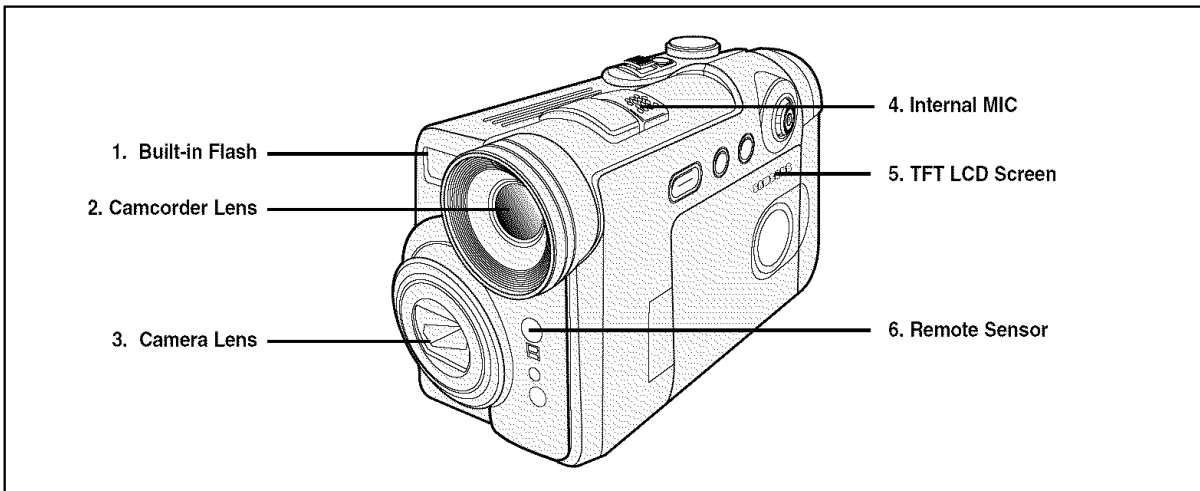

1. Built-in Flash (see page 108)

2. Camcorder Lens

3. Camera Lens

4. Internal MIC

5. TFT LCD Screen

6. Remote Sensor

Getting to Know Your Camcorder

Left Side View

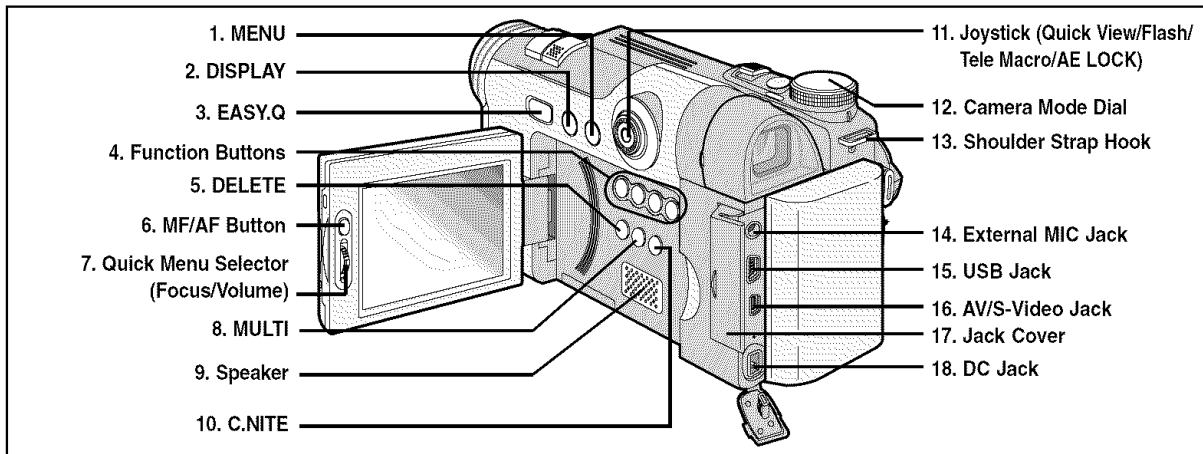

1. MENU

2. DISPLAY (see page 25)

3. EASY.Q (see page 42)

4. Function Buttons

Button	PLAY	REC	▶ (Play)
◀	REW	REC Search -	REV
▶▶	FF	REC Search +	FWD
▶	PLAY/STILL	FADE	-
■	STOP	BLC	-

5. DELETE (🗑️) (see page 101)

6. MF/AF Button (see page 110)

7. Quick Menu Selector (Focus/Volume)

8. MULTI (📷) (see page 101)

9. Speaker

10. C.NITE (see page 49)

11. Joystick (Quick View/Flash/Tele Macro/AE LOCK)

12. Camera Mode Dial

13. Shoulder Strap Hook (see page 20)

14. External MIC Jack

15. USB Jack

16. AV/S-Video Jack

17. Jack Cover

18. DC Jack

Getting to Know Your Camcorder

Right & Top View

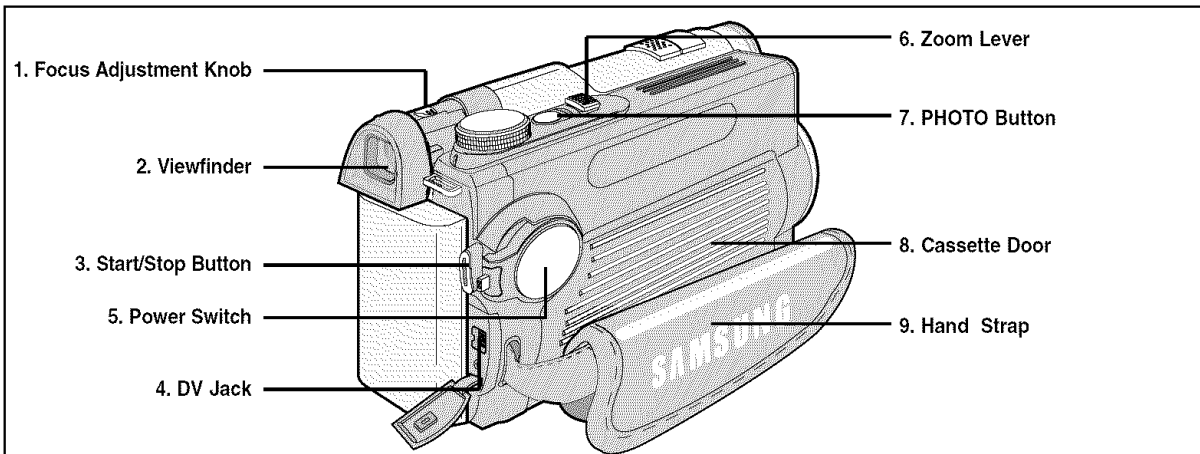

1. Focus Adjustment Knob (see page 37)
2. Viewfinder (see page 37)
3. Start/Stop Button
4. DV Jack
5. Power Switch (REC, PLAY, OFF or  (CAMERA))

6. Zoom Lever (see page 46)
7. PHOTO Button (see page 67)
8. Cassette Door
9. Hand Strap

Getting to Know Your Camcorder

Rear & Bottom View

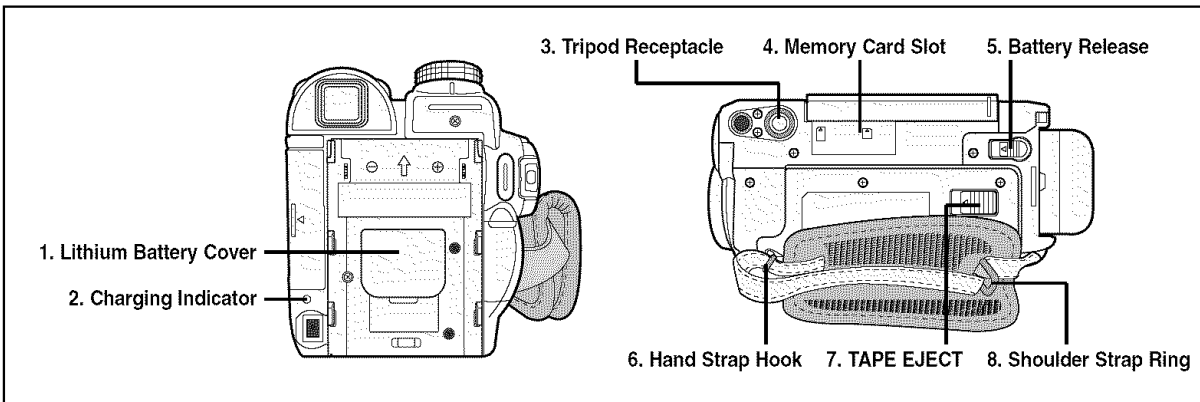

- 1. Lithium Battery Cover
- 2. Charging Indicator
- 3. Tripod Receptacle
- 4. Memory Card Slot
- 5. Battery Release
- 6. Hand Strap Hook
- 7. TAPE EJECT
- 8. Shoulder Strap Ring

Usable Memory Card

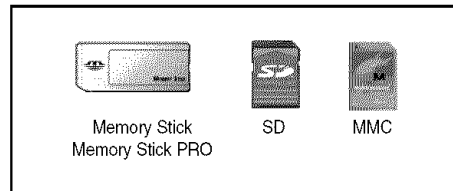

Getting to Know Your Camcorder

Remote Control

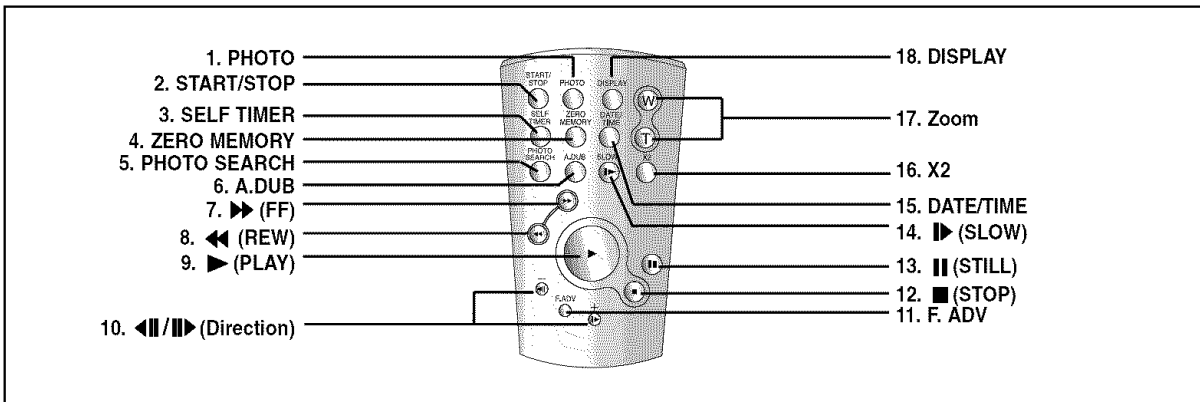

- | | |
|-----------------------------------|-------------------------------------|
| 1. PHOTO (see pages 67, 97) | 10. ◀◀/▶▶ (Direction) (see page 72) |
| 2. START/STOP | 11. F. ADV (see page 73) |
| 3. SELF TIMER (see pages 45, 103) | 12. ■ (STOP) |
| 4. ZERO MEMORY (see page 44) | 13. (STILL) |
| 5. PHOTO SEARCH (see page 67) | 14. ► (SLOW) (see page 72) |
| 6. A.DUB (see page 74) | 15. DATE/TIME |
| 7. ►► (FF) | 16. X2 (see page 73) |
| 8. ◀◀ (REW) | 17. Zoom |
| 9. ► (PLAY) | 18. DISPLAY |

Preparation

Adjusting the Hand Strap

- ❖ It is very important to ensure that the Hand strap has been correctly adjusted before you begin your recording. The Hand strap enables you to:
 - Hold the Camcorder in a stable, comfortable position.
 - Press the **ZOOM** and **Start/Stop** button without having to change the position of your hand.

Hand Strap

1. Pull and open the Hand Strap Cover and release the Hand Strap.
2. Insert the Hand Strap into the Hand Strap hook.
3. Insert your hand into the Hand Strap, adjust its length and stick it back onto the Hand Strap Cover.

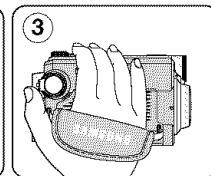
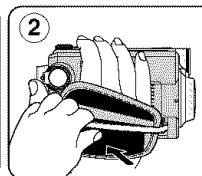
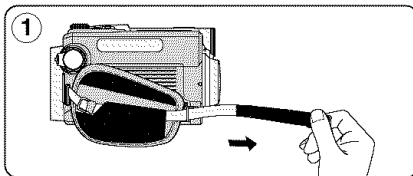

Shoulder Strap

The Shoulder Strap enables you to carry your camcorder around in complete safety.

1. Insert the end of Shoulder Strap into the Shoulder Strap Hook on the Camcorder.
2. Insert the other end of the strap into the ring attached to the Hand Strap.
3. Thread each end into the buckle, adjust the length of the strap and then pull it tight in the buckle.

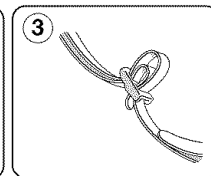
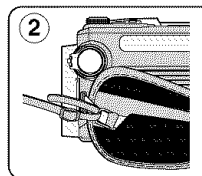
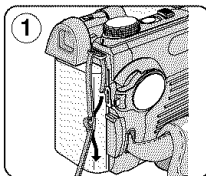

Attaching the Lens Cover

1. Hook up the Lens Cover with Lens Cover Strap as illustrated.
2. Pull and open the Hand Strap cover and release the Hand Strap.
3. Hook up the Lens cover strap to the Hand strap and adjust it following the steps as described for the Hand strap.
4. Close the Hand strap cover.

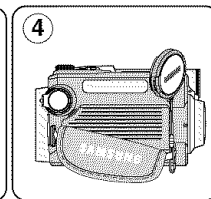
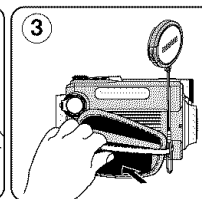
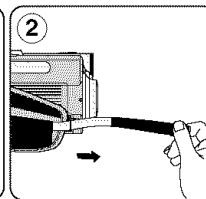
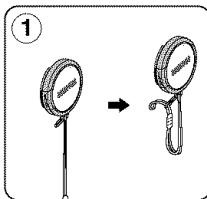

Preparation

Lithium Battery Installation

Battery Installation for the Internal Clock

- ❖ The Lithium battery maintains the clock function and preset contents of the memory; even if the Battery pack or AC Power adapter is removed.
- ❖ The Lithium battery for the Camcorder lasts about 6 months under normal operation from the time of installation.
- ❖ When the Lithium battery becomes weak or dead, the date/time indicator will display **12:00 AM JAN. 1, 2005** when you set the Date/Time to on.
When this occurs, replace the Lithium battery with type CR2025.

1. Remove the Lithium-ion battery from the rear of the Camcorder.
2. Open the Lithium battery cover on the rear of the Camcorder.
3. Position the Lithium battery in the Lithium battery holder, with the positive (+) terminal face up.
4. Close the Lithium battery cover.

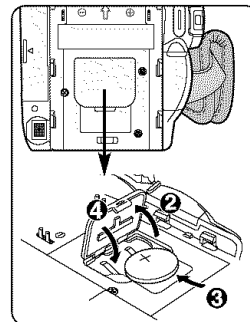

Battery Installation for the Remote Control

- ❖ You need to insert or replace the Lithium battery when:
 - You purchase the Camcorder.
 - The remote control doesn't work.
- ❖ Position the Lithium battery in the Lithium battery holder, with the positive (+) terminal face up.
- ❖ Be careful not to reverse the polarity of the battery.

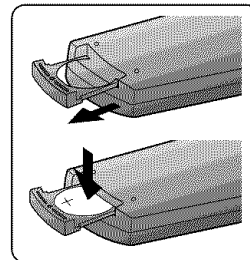

[Note]

The Lithium battery must be inserted in the correct direction.

Warning: Keep the Lithium battery out of the reach of the children.
Should any battery be swallowed, consult a doctor immediately.

Preparation

Connecting a Power Source

- ❖ There are two types of power source that can be connected to your Camcorder.
 - The AC Power adapter and AC Cord: used for indoor recording.
 - The Battery pack: used for outdoor recording.

To use the AC Power Adapter and DC Cable

1. Connect the AC Power adapter to the AC Cord.
2. Connect the AC Cord to a wall socket.

[Notes]

- You must use an AA-E8 TYPE AC Power adapter.
 - The plug and wall socket type may differ according to your resident country.
3. Connect the DC cable to the DC jack of the Camcorder.
 4. Set the Camcorder to each mode by holding down the tab on the **Power** switch and turning it to the **REC**, **PLAY**, **📷 (CAMERA)** or **OFF** mode.

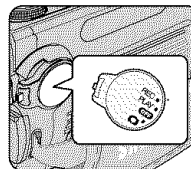
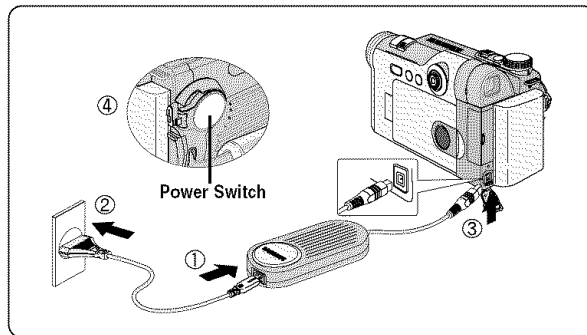

<REC Mode>

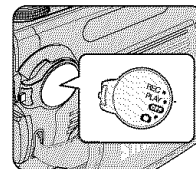

<PLAY Mode>

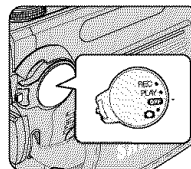

<OFF Mode>

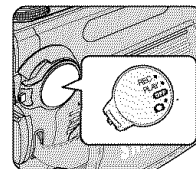

<CAMERA Mode>

Preparation

Using the Lithium Ion Battery Pack

- ❖ The amount of continuous recording time available depends on
 - The type and capacity of the Battery pack you are using.
 - How often the zoom function is used.
 It is recommended that you have several batteries available.

Charging the Lithium Ion Battery Pack

1. Attach the Battery pack to the Camcorder.
2. Connect the AC Power adapter to an AC Cord and connect the AC Cord to a wall socket.
3. Connect the DC cable to the DC jack on the Camcorder.
4. Turn the **Power** switch to **OFF**, and the charging indicator will start to flash, showing that the battery is charging.

Blinking time	Charging rate
Once per second	Less than 50%
Twice per second	50% ~ 75%
Three times per second	75% ~ 90%
Blinking stops and stays on	90% ~ 100%
On for a second and off for a second	Error - Reset the Battery pack and the DC cable

5. When the battery is fully charged, disconnect the Battery pack and the AC Power adapter from the Camcorder.
Even with the **Power** switched **OFF**, the Battery pack will still discharge.

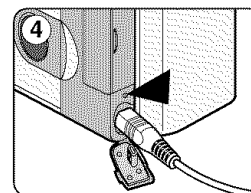
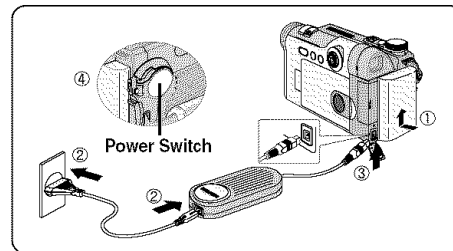

<Charging Indicator>

[Notes]

- The Battery pack may be charged a little at the time of purchase.
- To prevent reduction in the life and capacity of the Battery pack, always remove it from the Camcorder after it is fully charged.
- The amount of continuous recording time available depends on:
 - The type and capacity of the Battery pack you are using.
 - How often the zoom is used.
 - Type of use (Camcorder/Camera/With LCD screen etc.).
 - Ambient temperature.
 It is recommended to have additional battery packs available.
- Even when the Power switched to OFF, the Battery pack will still discharge if it is left attached to the device.

Preparation

Table of continuous Recording Time based on Model and Battery Type.

- ❖ If you close the LCD screen, it switches off and the Viewfinder switches on automatically.
- ❖ The continuous recording times given in the table below are approximations. Actual recording time depends on usage.

Battery \ Time	Charging time	Continuous recording time	
		LCD ON	VIEWFINDER ON
SB-LS110	Approx. 2hr	Approx. 1hr 30min	Approx. 2hr
SB-LS220	Approx. 3hr 30min	Approx. 3hr 10min	Approx. 4hr 10min

[Notes]

- The Battery pack should be recharged in an environment between 32 °F (0 °C) and 104 °F (40 °C).
- The Battery pack should never be charged in a room with a temperature that is below 32 °F (0 °C).
- The life and capacity of the Battery pack will be reduced if it is used in temperatures below 32 °F (0 °C) or left in temperatures above 104 °F (40 °C) for a long period of time, even when it is fully recharged.
- Do not put the Battery pack near any heat source (i.e. fire or a heater).
- Do not disassemble, apply pressure to or heat the Battery pack.
- Do not allow the + and – terminals of the Battery pack to be short-circuited. It may cause leakage, heat generation, induce overheating or fire.
- Use SB-LS110 or SB-LS220 Battery pack only.
- Be sure to use a recommended battery pack as described above. The batteries are available at a SAMSUNG retailer.

Preparation

Battery Level Display

✦ The battery level display indicates the amount of power remaining in the Battery pack.

- a. Fully charged
 - b. 20~40% used
 - c. 40~80% used
 - d. 80~95% used
 - e. Completely used (Blinking)
(The Camcorder will turn off soon, change the battery as soon as possible)
- Tips for battery Identification

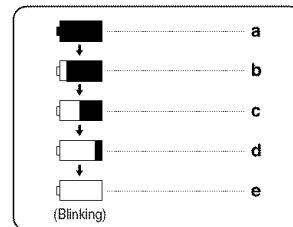

<Camcorder Mode>

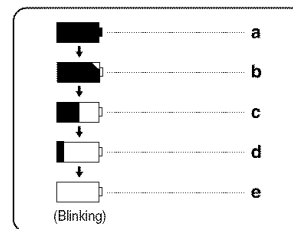

<Camera Mode>

[Notes]

- Please refer to the Table on page 24 for approximate continuous recording time.
 - The recording time is affected by temperature and environmental conditions.
 - The recording time shortens dramatically in a cold environment.
- The continuous recording times in the operating instructions are measured using a fully charged Battery pack at 77 °F (25 °C). As the environmental temperature and conditions vary. The remaining battery time may differ from the approximate continuous recording times given in the instructions.

Turning the OSD (On Screen Display) On/Off

■ Turning OSD on/off

Press the **DISPLAY** button on the left side control panel.

- Each press of the button toggles the OSD function on and off.
- When you turn the OSD off,

In REC Mode: The STBY, REC modes are always displayed on the OSD, even when the OSD is turned off and the key input is displayed for 3 seconds then turned off.

In PLAY Mode: When you press any function button, the function is displayed on the OSD for 3 seconds before it turns off.

■ Turning the Date/Time on/off

To turn the Date/Time on or off, access the menu and change the Date/Time mode. (see page 35)

Preparation

OSD (On Screen Display) in REC/PLAY Modes

- | | |
|---|---|
| 1. Battery Level (see page 25) | 19. Tape Counter |
| 2. Manual Focus (see page 56) | 20. Zero Memory (see page 44) |
| 3. EASY.Q (see page 42) | 21. Record Speed Mode |
| 4. DIS (see page 59) | 22. Operating Mode |
| 5. Program AE (see page 61) | 23. Self Timer |
| 6. White Balance Mode (see page 57) | 24. Photo Image |
| 7. Shutter Speed (see page 55) | 25. Tele Macro (see page 46) |
| 8. Exposure (see page 55) | 26. Audio Playback |
| 9. Digital Effects Mode (see page 63) | 27. DEW (see page 9) |
| 10. Date/Time (see page 34) | 28. Warning Indicator (see page 147) |
| 11. Zoom Position (see page 46) | 29. Message Line (see page 147) |
| 12. Color Nite (see page 49) | 30. Volume Control (see page 69) |
| 13. USB | 31. DV IN (DV data transfer mode) (see page 77) |
| 14. Remote (see page 31) | 32. Audio Dubbing (see page 74) |
| 15. Wind Cut (see page 54) | |
| 16. BLC (Back Light Compensation) (see page 48) | |
| 17. Audio Mode (see page 53) | |
| 18. Remaining Tape (measured in minutes) | |

OSD in REC Mode

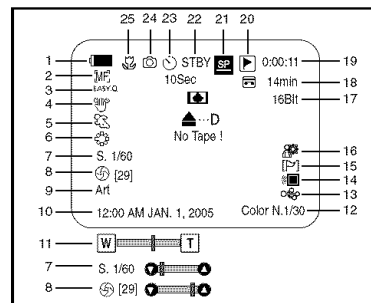

OSD in PLAY Mode

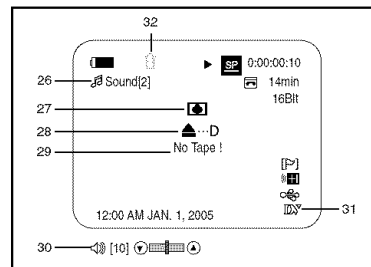

Preparation

OSD (On Screen Display) in (Program)/ (Play) Modes

1. Battery Level (see page 25)
2. Camera Mode
3. F (Aperture Range) No. (see page 117)
4. Shutter Speed (see page 118)
5. Flash Mode (see page 108)
6. Self Timer
7. Manual Focus (see page 110)
8. Tele Macro (see page 112)
9. Metering Mode (see page 114)
10. CARD (Memory Card) indicator
11. AE LOCK (see page 113)
12. Focus Area
13. Date/Time (see page 90)
14. Exposure Compensation (see page 116)
15. White Balance Mode (see page 119)
16. ISO Sensitivity (see page 121)
17. Sharpness (see page 125)
18. Image Quality (see page 86) or MPEG Frame Rate (see page 104)
19. Image Size (see page 87)
20. Image Counter
Total number of recordable still and moving images.
21. Zoom Position (see page 126)
22. Play Mode
23. Moving Image Indicator (see page 106)
24. Erase protection Indicator (see page 133)
25. Print mark (see page 141)
26. Message Line (see page 147)
27. Image Counter
Current Image/Total number of recorded images

OSD in (Program) Mode

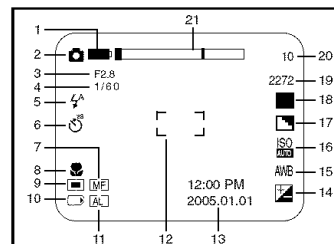

OSD in (Play) Mode

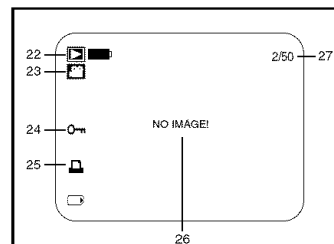

Preparation

Using the Joystick

- ❖ The Joystick is used to make a selection and to move the cursor left, right, up and down. Using the Joystick, you can easily make your selection and navigate the menu.
1. Move to a previous menu item / Adjust the selected item (to the left).
 2. Move to a sub menu item / Adjust the selected item (to the right).
 3. Move to a lower menu item.
 4. Move to an upper menu item.
 5. Press to select the chosen item.

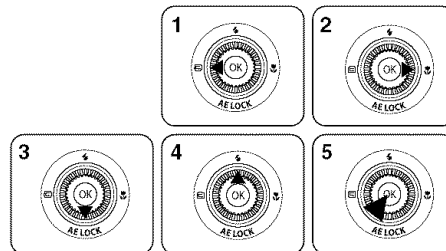

The Camcorder : System Menu Setting

Selecting the OSD Language

- ❖ The Language function works in both REC and PLAY modes.
- ❖ Select the appropriate OSD Language from OSD List.

1. Set the **Power** switch to **REC** or **PLAY**.
2. Press the **MENU** button.
 - The menu list will appear.
3. Move the **Joystick** up or down to select **System**, then press the **Joystick(OK)**.
4. Move the **Joystick** up or down to select **Language**, then press the **Joystick(OK)**.
 - The available language options are listed.
5. Move the **Joystick** up or down to select desired OSD language, then press the **Joystick(OK)**.
 - The OSD language is refreshed in selected language.
6. To exit, press the **MENU** button.

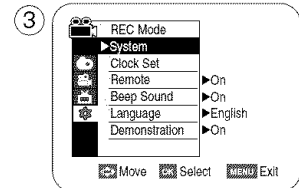
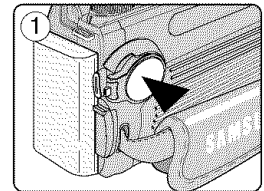

[Notes]

- The word “Language” in the menu is always indicated in English.
- A separate Language selecting function is provided for the Digital Camera (see page 88).

The Camcorder : System Menu Setting

Setting the Clock

- ❖ Clock setup works in both REC and PLAY modes.
 - ❖ The Date/Time is automatically recorded onto a tape.
Before recording, please set the Date/Time.
1. Set the **Power** switch to **REC** or **PLAY**.
 2. Press the **MENU** button.
 - The menu list will appear.
 3. Move the **Joystick** up or down to select **System**, then press the **Joystick(OK)**.
 4. Move the **Joystick** up or down to select **Clock Set**, then press the **Joystick(OK)**.
 - The year will highlight first.
 5. Move the **Joystick** up or down to set current Year, then press the **Joystick(OK)**.
 - The month will be highlighted.
 6. You can set the month, day, hour and minute following the same procedure for setting the year.
 7. Press the **Joystick(OK)** after setting the minutes.
 - The message **Complete!** will be displayed.
 - To adjust the clock, select the Year, Month, Day, Hour or Min by pressing the **Joystick(OK)**, then move the **Joystick** up or down to set respective values.
 8. To exit, press the **MENU** button.

[Notes]

- After the Lithium battery loses its charge (after about 6 months), the date/time appears on the screen as 12:00 AM JAN. 1, 2005.
- You can set the year up to 2037.
- If the Lithium battery is not installed, any input data will not be backed up.
- A separate Clock setting function is provided for the Digital Camera (see page 90).

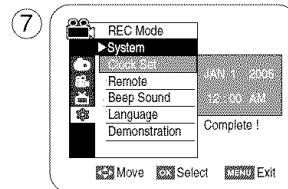
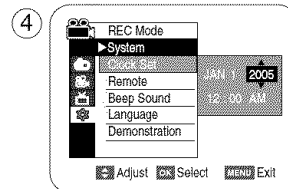
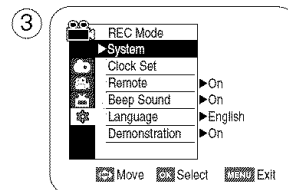

The Camcorder : System Menu Setting

Setting the Wireless Remote Control Acceptance (Remote)

- ❖ The Remote function works in both REC and PLAY modes.
- ❖ The Remote option allows you to enable or disable the remote control for use with the Camcorder.

1. Set the **Power** switch to **REC** or **PLAY**.
2. Press the **MENU** button.
 - The menu list will appear.
3. Move the **Joystick** up or down to select **System**, then press the **Joystick(OK)**.
4. Move the **Joystick** up or down to select **Remote**, then press the **Joystick(OK)**.
5. Move the **Joystick** up or down to select **On** or **Off**, then press the **Joystick(OK)**.
6. To exit, press the **MENU** button.

[Notes]

- If you set the Remote to Off in the menu and try to use it, the remote control icon(Ⓜ) will blink for 3 seconds on the LCD screen and then disappear.
- A separate Remote Control selecting function is provided for the Digital Camera (see page 92).

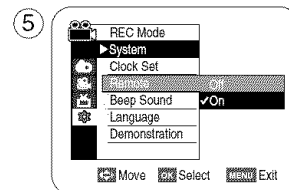
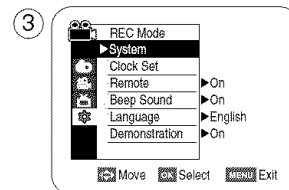
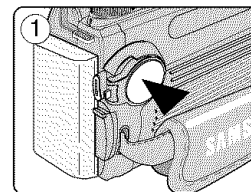

The Camcorder : System Menu Setting

Setting the Beep Sound

- ❖ The Beep Sound function works in both REC and PLAY modes.
- ❖ You can turn the Beep Sound on or off. When on, each press of a button sounds a beep.

1. Set the **Power** switch to **REC** or **PLAY**.
2. Press the **MENU** button.
 - The menu list will appear.
3. Move the **Joystick** up or down to select **System**, then press the **Joystick(OK)**.
4. Move the **Joystick** up or down to select **Beep Sound**, then press the **Joystick(OK)**.
5. Move the **Joystick** up or down to select **On** or **Off**, then press the **Joystick(OK)**.
6. To exit, press the **MENU** button.

[Note]

A separate Beep Sound setting function is provided for the Digital Camera (see page 93).

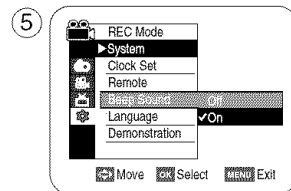
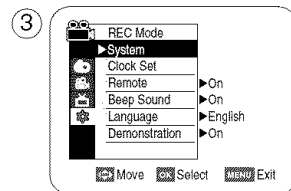
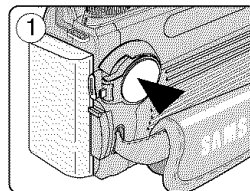

The Camcorder : System Menu Setting

Viewing the Demonstration

- ❖ Before you begin: Make sure that there is no tape inserted in the Camcorder. (see page 38)
- ❖ Demonstration automatically shows you the major functions that are included with your Camcorder so that you may use them more easily.
- ❖ The Demonstration function may only be used in the REC mode without a tape inserted in the Camcorder.
- ❖ The Demonstration operates repeatedly until the Demonstration mode switched Off.

1. Set the **Power** switch to **REC**.
2. Press the **MENU** button.
 - The menu list will appear.
3. Move the **Joystick** up or down to select **System**, then press the **Joystick(OK)**.
4. Move the **Joystick** up or down to select **Demonstration**, then press the **Joystick(OK)**.
5. Move the **Joystick** up or down to select **On**, then press the **Joystick(OK)**.
6. Press the **MENU** button.
 - The Demonstration will begin.
7. To quit the Demonstration, press the **MENU** button.

[Notes]

- The Demonstration mode is automatically activated when the Camcorder is left idle for more than 10 minutes after switching to the REC mode (no tape is inserted in the Camcorder).
- If you press other buttons (FADE, BLC, PHOTO, EASY.Q) during the Demonstration mode, the demonstration stops temporarily and resumes 10 minutes later if you do not operate any other functions.

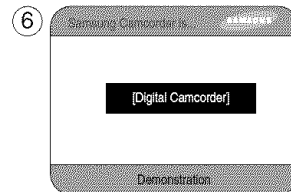
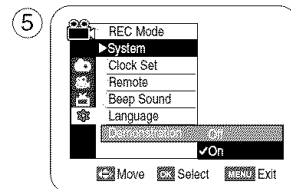
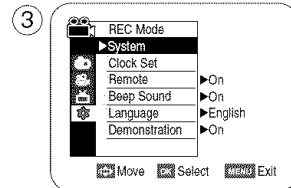
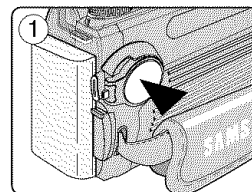

The Camcorder : Display Menu Setting

Adjusting the LCD Screen

- ❖ This function works in both REC and PLAY modes.
- ❖ Your Camcorder is equipped with a 2.5 inch color Liquid Crystal Display(LCD) screen, which enables you to view what you are recording or playing back directly.
- ❖ Depending on the conditions under which you are using the Camcorder (indoors or outdoors for example), you can adjust;
 - LCD Bright
 - LCD Color

1. Set the **Power** switch to **REC** or **PLAY**.
2. Press the **MENU** button.
 - The menu list will appear.
3. Move the **Joystick** up or down to select **Display**, then press the **Joystick(OK)**.
4. Move the **Joystick** up or down to select the item you want to adjust (**LCD Bright** or **LCD Color**), then press the **Joystick(OK)**.
5. Move the **Joystick** up or down to adjust the value of the selected item (**LCD Bright** or **LCD Color**), then press the **Joystick(OK)**.
 - You can set values for **LCD Bright** and **LCD Color** between 0~35.
6. To exit, press the **MENU** button.
 - LCD Bright & LCD Color functions do not affect the brightness and color of the image to be recorded.

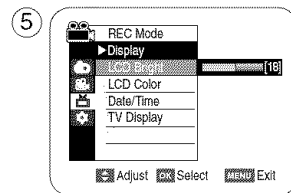
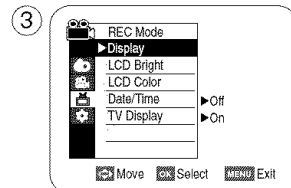
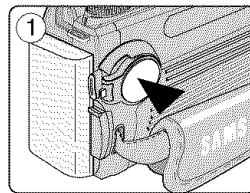

The Camcorder : Display Menu Setting

Displaying the Date/Time

- ❖ The Date/Time function works in both REC and PLAY modes.
- ❖ The date and time are automatically recorded on a special data area of the tape.

1. Set the **Power** switch to **REC** or **PLAY**.
2. Press the **MENU** button.
 - The menu list will appear.
3. Move the **Joystick** up or down to select **Display**, then press the **Joystick(OK)**.
4. Move the **Joystick** up or down to select **Date/Time**, then press the **Joystick(OK)**.
5. Move the **Joystick** up or down to select the Date/Time display type, then press the **Joystick(OK)**.
 - Display type of the Date/Time: Off, Date, Time, Date&Time
6. To exit, press the **MENU** button.

[Notes]

- The Date/Time will read **12:00 AM JAN. 1, 2005** in the following conditions.
 - During playback of a blank section of a tape.
 - If the tape was recorded before setting the Date/Time in the Camcorder.
 - When the Lithium battery becomes weak or dead.
- Before you use the Date/Time function, you must set the clock. See Setting the Clock on page 30.

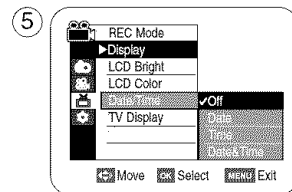
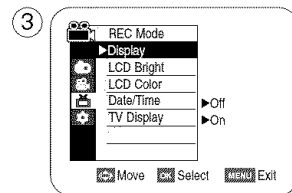
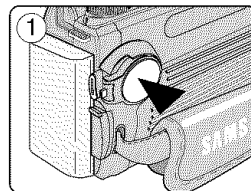

The Camcorder : Display Menu Setting

Setting the TV Display

- ❖ The TV Display function works in both REC and PLAY modes.
- ❖ You can select the output path of the OSD (On Screen Display).
 - Off: The OSD appears in the LCD screen and Viewfinder only.
 - On: The OSD appears in the LCD screen, Viewfinder and TV.
- Use the DISPLAY button located at the left side of the Camcorder to turn the OSD on/off on the LCD screen/Viewfinder/TV.

1. Set the **Power** switch to **REC** or **PLAY**.
2. Press the **MENU** button.
 - The menu list will appear.
3. Move the **Joystick** up or down to select **Display**, then press the **Joystick(OK)**.
4. Move the **Joystick** up or down to select **TV Display**, then press the **Joystick(OK)**.
5. To activate TV Display function, move the **Joystick** up or down to select **On** or **Off**, then press the **Joystick(OK)**.
6. To exit, press the **MENU** button.

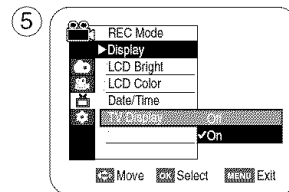
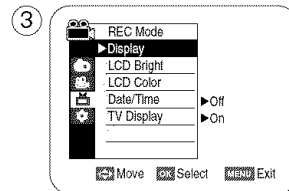
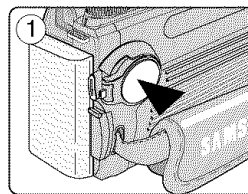

The Camcorder : Basic Recording

Using the Viewfinder

- ❖ The Viewfinder will work when the LCD screen is closed.

Adjusting the Focus

The focus adjustment knob of the Viewfinder enables individuals with vision problems to see clearer images.

1. Close the LCD screen and pull out the Viewfinder.
2. Use the focus adjustment knob of the Viewfinder to focus the picture.

[Notes]

- Viewing the sun or any strong light source through the Viewfinder for a prolonged period may be harmful, or cause temporary impairment.
- The Viewfinder will work either in PLAY mode with LCD screen closed or in REC mode with LCD screen closed or facing the front.

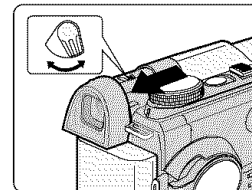

The Camcorder : Basic Recording

Inserting and Ejecting a Cassette

- ❖ When inserting a tape or closing the cassette compartment, do not apply excessive force, as it may cause a malfunction.
- ❖ Do not use any tape other than Mini DV cassettes.

1. Connect a power source and slide the **TAPE EJECT** switch and open the cassette door.
 - The cassette holder automatically rises and opens forward.
2. Insert a tape into the cassette compartment with the tape window facing outward and the protection tab toward the top. (Inserting a Cassette)
 - Remove the cassette tape, which is automatically ejected by pulling the cassette out. (Ejecting a Cassette)
3. Press the area marked **PUSH** on the cassette door until it clicks into place.
 - Be careful to keep the hand strap away from the cassette door when closing it. Closing the cassette door with the hand strap inside may cause damage to the unit.
 - The cassette is loaded automatically.
4. Close the cassette door.

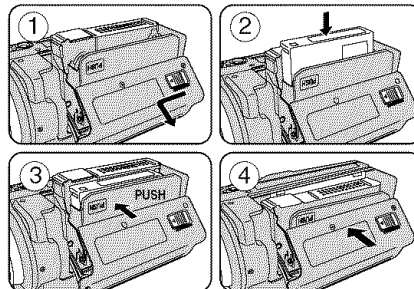

[Note]

When you have recorded something that you wish to keep, you can protect it so that it will not be accidentally erased.

a. Protecting a tape:

Push the safety tab on the cassette so that the hole is uncovered.

b. Removing the tape protection:

If you no longer wish to keep the recording on the cassette, push the safety tab back so that it covers the hole.

How to store a tape

- a. Avoid places with magnets or magnetic interference.
- b. Avoid humidity and dust prone places.
- c. Keep the tape in an upright position and avoid storing it in direct sunlight.
- d. Avoid dropping or knocking your tapes.

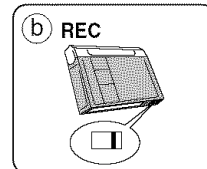
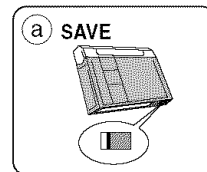

The Camcorder : Basic Recording

Hints for Stable Image Recording

- ❖ While recording, it is very important to hold the Camcorder correctly.
- ❖ Fix the lens cover firmly by clipping it to the hand strap. (see page 20)

Recording with the LCD Screen

1. Hold the Camcorder firmly using the hand strap.
2. Place your right elbow against your side.
3. Place your left hand under or beside the LCD screen to support and adjust it.
Do not touch the built-in microphone.
4. Choose a comfortable, stable position for the shots that you are taking.
You can lean against a wall or on a table for greater stability.
Do not forget to breathe gently.
5. Use the LCD frame as a guide to determine the horizontal plane.
6. Whenever possible, use a tripod.



Recording with the Viewfinder

1. Hold the Camcorder firmly using the hand strap.
2. Place your right elbow against your side.
3. Place your left hand under the Camcorder to support it.
Be sure not to touch the built-in microphone.
4. Choose a comfortable, stable position for the shots that you are taking.
You can lean against a wall or on a table for greater stability.
5. To view an object through the Viewfinder, pull it out until you hear the click sound.
Excessive force may cause damage to the Viewfinder.
6. Place your eye firmly against the Viewfinder eyecup.
7. Use the Viewfinder frame as a guide to determine the horizontal plane.
8. Whenever possible, use a tripod.

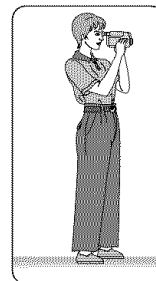

The Camcorder : Basic Recording

Various Recording Techniques

❖ In some situations different recording techniques may be required for more dramatic results.

1. General recording.

2. Downward recording.

Making a recording with a top view of the LCD screen.

3. Upward recording.

Making a recording viewing the LCD screen from below.

4. Self recording.

Making a recording viewing the LCD screen from the front.

5. Recording with the Viewfinder.

In circumstances where it is difficult to use the LCD screen, the Viewfinder can be used as a convenient alternative.

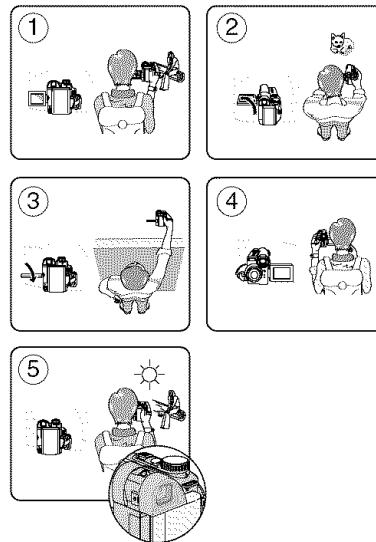

[Note]

Please rotate the LCD screen carefully as excessive rotation may cause damage to the inside of the hinge that connects the LCD screen to the Camcorder.

The Camcorder : Basic Recording

Making your First Recording

1. Connect a power source to the Camcorder. (see page 22)
(A Battery pack or a AC Power adapter)
Insert a cassette. (see page 38)
2. Remove the Lens cover.
3. Set the **Power** switch to **REC.**
 - Open the LCD screen.
Make sure that **STBY** is displayed.
 - If the write protection tab of the cassette is open (set to save), **STOP** and **Protection !** will be displayed.
Release the write protection tab to record.
 - Make sure the image you want to record appears on the LCD screen or Viewfinder.
 - Make sure the battery level indicates that there is enough remaining power for your expected recording time.
4. To start recording, press the **Start/Stop** button.
 - **REC ●** is displayed on the LCD screen.

To stop recording, press the **Start/Stop** button again.

 - **STBY** is displayed on the LCD screen.

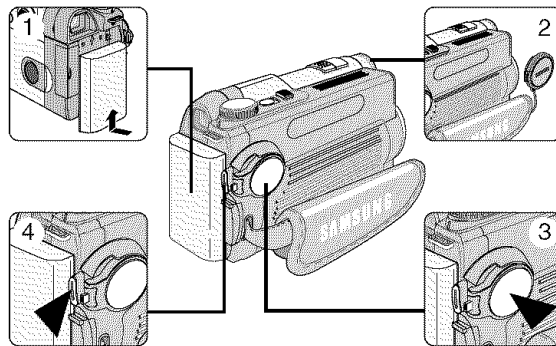

[Note]

Detach the Battery pack when you are finished recording to prevent unnecessary battery power consumption.

The Camcorder : Basic Recording

Using EASY.Q Mode (for Beginners)

- ❖ The EASY.Q mode works only in REC mode.
- ❖ The EASY.Q mode allows a beginner to easily make good recordings.

1. Set the **Power** switch to **REC**.
2. By pressing the **EASY.Q** button, all functions on the Camcorder will be set to off and the recording settings will be set to the following basic modes:
 - Battery level, recording mode, counter, date/time, and DIS (📷) will be displayed.
 - The word **EASY.Q** will appear on the LCD screen at the same time.
However, the Date/Time will only be seen if it has been previously set. (see page 35)
3. Press the **Start/Stop** button to start recording.
Recording will begin using the basic automatic settings.
4. Press the **EASY.Q** button again in the **STBY** mode and then turn the EASY.Q mode off.
 - The EASY.Q function will not turn off while you are recording.
 - The camcorder will return to the settings that were set prior to activating EASY.Q mode.

[Notes]

- In EASY.Q mode, certain functions are not available, such as Menu, BLC, Manual focus.
If you want to use these functions, you must first turn the EASY.Q mode off.
- The EASY.Q mode settings are released when the Battery pack is removed from the Camcorder and must be reset when the Battery pack is replaced.
- EASY.Q mode will not turn off during a recording.
- Photo image recording using the PHOTO button while EASY.Q is set releases DIS function.
- Digital Zoom, Color Nite or Digital Effect is not available in the EASY.Q mode.

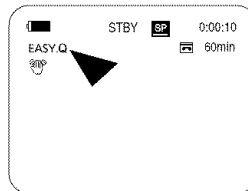
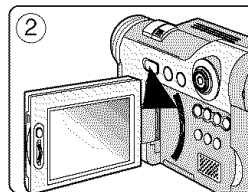
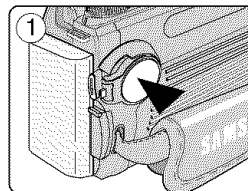

The Camcorder : Basic Recording

When a cassette is loaded and the Camcorder is left in the STBY mode for more than 5 minutes without being used, it will switch off automatically.

To use it again, press the Start/Stop button or set the Power switch to OFF and then back to REC.

This auto power off feature is designed to save battery power.

Record Search

- You can view a recording using the **Record Search +, –** function in **STBY** mode.
Record Search – enables you to play the recording backwards and
Record Search + enables you to play it forwards, as long as you keep each button pressed down.
- If you press the **Record Search –** button in **STBY** mode, your Camcorder will play in reverse for 3 seconds and return to the original position automatically.

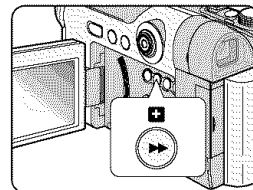
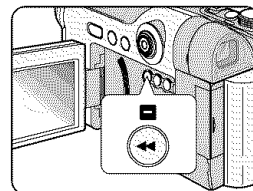

[Note]

Mosaic shaped distortion may appear on the screen while in Record Search mode.



The Camcorder : Basic Recording

Setting the Zero Memory

- ❖ The Zero Memory function works in both REC and PLAY modes.
 - ❖ You can mark a point on a tape that you want to return to following playback.
1. Set the Power switch to **REC** or **PLAY**.
 2. Press the **ZERO MEMORY** button on the remote control before the recording or during playback at the point where you wish to return.
 - The time code is changed to a tape counter that is set to Zero Memory with the  **0:00:00** (Zero Memory indicator).
 - If you want to cancel the Zero Memory function, press the **ZERO MEMORY** button again.
 3. Finding the zero position.
 - When you have finished playback, fast forward or rewind the tape in stop mode. The tape stops automatically when it reaches the zero position.
 - When you have finished recording, set the **Power** switch to **PLAY** and press the  (REW) button. The tape stops automatically when it reaches the zero position.
 4. The tape counter with the  (Zero Memory indicator) disappears from the display and the tape counter is changed to the time code.

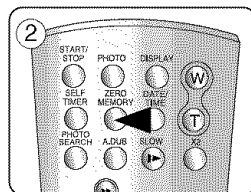
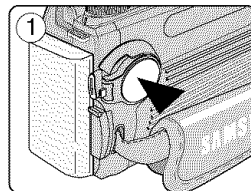

[Notes]

- In the following situations, Zero Memory mode may be canceled automatically:
 - At the end of the section marked with the Zero Memory function.
 - When the tape is ejected.
 - When you remove the Battery pack or power supply.
- The Zero Memory may not function correctly where there is a break between recordings on the tape.

The Camcorder : Basic Recording

Self Record using the Remote Control

- ❖ The Self Timer function works only in REC mode.
- ❖ When you use the Self Timer function on the remote control, the recording begins automatically in 10 seconds.

1. Set the **Power** switch to **REC**.
2. Press the **SELF TIMER** button until the appropriate indicator is displayed in the LCD screen.
3. Press the **Start/Stop** button to start the timer.
 - Self Timer starts counting down from 10 with a beep sound.
 - In the last one second of the countdown, the beep sound gets faster, then recording starts automatically.
 - If you want to cancel the Self Timer function before recording, press the **SELF TIMER** button.
4. Press the **Start/Stop** button again when you wish to stop recording.

[Notes]

- Do not obstruct the remote control sensor by putting obstacles between the remote control and Camcorder.
- The remote control range is 4 ~5m (13 ~17 ft).
- The effective remote control angle is up to 30 degrees left /right from the center line.
- Using a tripod is recommended during the Self Record

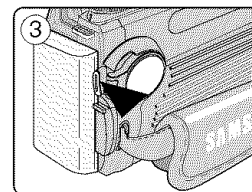
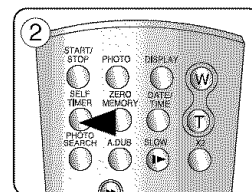
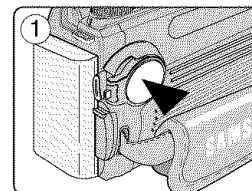

The Camcorder : Basic Recording

Zooming In and Out

- ❖ The Zoom lever works only in REC mode.
- ❖ Zooming is a recording technique that lets you change the size of the subject in a scene.
- ❖ You can zoom using variable zoom speeds.
- ❖ Use these features for different shots. Please note that over-use of the Zoom feature can lead to unprofessional looking results and a reduction of battery usage time.

1. Move the Zoom lever slightly for a gradual zoom, move it further for a high-speed zoom.
 - Your zooming is monitored on the OSD.
2. T(Telephoto) side: Subject appears closer.
3. W(Wide angle) side: Subject appears farther away.
 - You can record a subject that is about 10mm (about 0.5 inch) away from the lens surface in the Wide position.

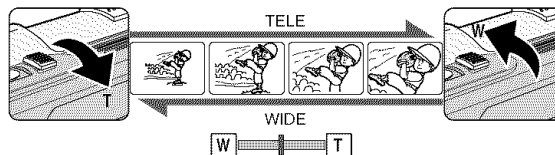

Using the Tele Macro

- ❖ Tele Macro Function works only in REC mode.
 - ❖ Effective focal distance in tele macro mode is 50 Cm (19.7 inches) ~ 100 Cm (39.4 inches).
1. Move the **Joystick** to the right.
 - Tele Macro Icon () will be displayed.
 2. If you want to cancel the Tele Macro function, move the **Joystick** to the right again.

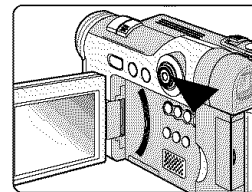

[Notes]

- When recording in Tele Macro mode, the focus speed may be slow.
- When you operate the Zoom function in the Tele Macro mode, the recording subject may be out of focus.
- Use a tripod to prevent hand shake in the Tele Macro mode.
- Avoid shadows when recording in the Tele Macro mode.
- As the distance to the subject decreases, focusing area narrows.
- When you can not get proper focus, use the Zoom lever.

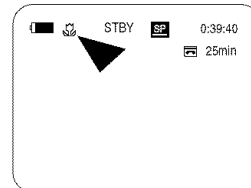

The Camcorder : Basic Recording

Using the Fade In and Out

- ❖ The FADE function works only in REC mode.
- ❖ You can give your recording a professional look by using special effects such as fade in at the beginning of a sequence or fade out at the end of a sequence.

To Start Recording

1. Set the **Power** switch to **REC**.
2. Before recording, hold down the **FADE** button.
 - The picture and sound gradually disappear (fade out).
3. Press the **Start/Stop** button and at the same time release the **FADE** button. Recording starts and the picture and sound gradually appear (fade in).

To Stop Recording (use Fade In/Fade Out)

4. When you wish to stop recording, hold down the **FADE** button.
 - The picture and sound gradually disappear (fade out).
5. When the picture has disappeared, press the **Start/Stop** button to stop recording.

a. Fade Out

(Approx. 4 seconds)

b. Fade In

(Approx. 4 seconds)

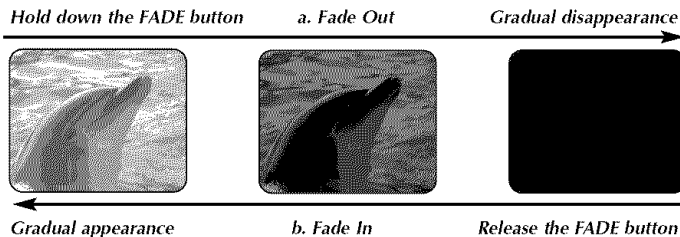
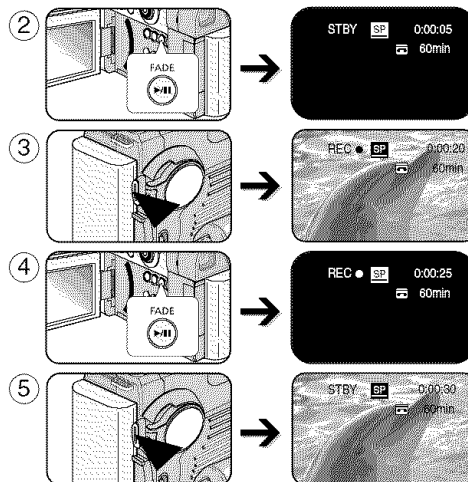

The Camcorder : Basic Recording

Using Back Light Compensation Mode (BLC)

- ❖ BLC works only in REC mode.
- ❖ Back lighting exists when the subject is darker than the background:
 - The subject is in front of a window.
 - The person to be recorded is wearing white or shiny clothes and is placed against a bright background; the person's face is too dark to distinguish his/her features.
 - The subject is outdoors and the background is overcast.
 - The light sources are too bright.
 - The subject is against a snowy background.

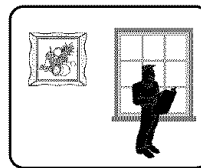

<BLC off>

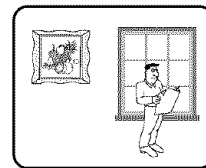

<BLC on>

1. Set the **Power** switch to **REC**.
2. Press the **BLC** button.
 - BLC icon () will be displayed.
3. To exit BLC mode, press the **BLC** button again.
 - Each press of the **BLC** button toggles: Normal → BLC → Normal.

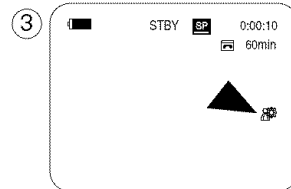
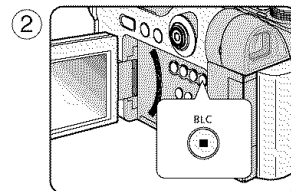

[Note]

The BLC function will not operate in EASY.Q mode.

The Camcorder : Basic Recording

Using the Color Nite

- ❖ Color Nite function works only in REC mode.
- ❖ Shutter speed can be controlled, allowing you to record slow moving objects.
- ❖ Color Nite function may produce a brighter image.

1. Set the **Power** switch to **REC**.
2. Press the **C.NITE** button.
3. Each time you press the **C.NITE** button, shutter speed is changed to **Color N. 1/30**, **Color N. 1/15** and off.

[Notes]

- The Color Nite will not turn ON or OFF while you are recording.
- When using Color Nite, the image takes on a slow motion like effect.
- When using Color Nite function, the focus adjusts slowly and white dots may appear on the screen, this is not a defect.
- Color Nite is not available while DIS, Photo image recording or EASY.Q is in use.
- Digital Zoom, Photo image recording, Mosaic, Mirror, Emboss2, Pastel2 or 16:9 Wide is not available in Color Nite mode.
- If DIS or EASY.Q is set, Color Nite mode will be released.

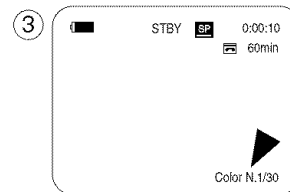
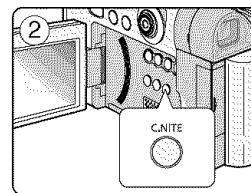
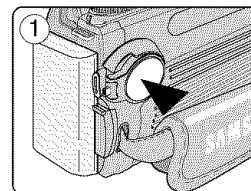

The Camcorder : Advanced Recording

Use of various Functions

Setting menu items

Main Menu	Sub Menu	Functions	Available mode		Page
			REC	PLAY	
Camera	Program AE	Selecting the Program AE Function	✓		61
	White Balance	Setting White Balance	✓		57, 58
	Digital Effect	Setting the Digital special effect	✓		63
	DIS	Selecting the Digital Image Stabilizing	✓		59, 60
	Digital Zoom	Selecting Digital Zoom	✓		66
Tape	Photo Search	Searching pictures recorded in Tape		✓	67
	Audio Select	Selecting the Audio playback channel		✓	75
Record	Rec Mode	Selecting the recording speed	✓	✓	52
	Audio Mode	Selecting Sound Quality for recording	✓	✓	53
	Wind Cut	Minimizing wind noise	✓	✓	54
Display	LCD Bright	Setting the Brightness tone of the LCD screen	✓	✓	34
	LCD Color	Setting the Color tones of the LCD screen	✓	✓	34
	Date/Time	Setting the Date and Time	✓	✓	35
	TV Display	Selecting OSD on/off of TV	✓	✓	36
System	Clock Set	Setting the time	✓	✓	30
	Remote	Using the remote control	✓	✓	31
	Beep Sound	Setting the Beep sound	✓	✓	32
	Language	Selecting the OSD language	✓	✓	29
	Demonstration	Demonstration	✓		33

The Camcorder : Advanced Recording

Function availability in each Mode

Selected Mode Operating Mode		Digital functions				Digital Effects		
		DIS	Digital Zoom	PHOTO (Tape)	Color Nite	16:9 Wide	Emboss2, Pastel2, Mirror, Mosaic	Other Digital Effects
DIS			×	☆	×	×	×	○
Digital Zoom		△		☆	☆	☆	☆	○
PHOTO(Tape)		×	×		×	×	×	×
Color Nite		△	×	×		×	×	○
Digital Effects	16:9 Wide	△	×	×	△			
	Emboss2, Pastel2, Mirror, Mosaic	△	×	○	△			
	Other Digital Effects	○	○	○	○			

○ : The selected mode will work in this operating mode.

×

△ : The selected mode will work, and the operating mode will be released simultaneously.

☆ : Only the selected mode will be operated. After releasing the selected mode, the operating mode is enabled again.

[Note]

When you select an item that cannot be changed, an error message will be displayed.

The Camcorder : Advanced Recording

Selecting the Record Mode

- ❖ The Record Mode function works in both REC and PLAY (DV IN) modes.
- ❖ This Camcorder records and plays back in SP (standard play) mode and in LP (long play) mode.
 - SP (standard play): This mode permits 60 minutes of recording time with a DVM60 tape.
 - LP (long play): This mode permits 90 minutes of recording time with a DVM60 tape.

1. Set the **Power** switch to **REC** or **PLAY**.
2. Press the **MENU** button.
 - The menu list will appear.
3. Move the **Joystick** up or down to select **Record**, then press the **Joystick(OK)**.
4. Move the **Joystick** up or down to select **Rec Mode**, then press the **Joystick(OK)**.
5. Move the **Joystick** up or down to select desired record mode (**SP** or **LP**), then press the **Joystick(OK)**.
6. To exit, press the **MENU** button.
 - The selected icon will be displayed.

[Notes]

- We recommend that you use this Camcorder to play back any tapes recorded on this Camcorder. Playing back a tape recorded in other equipment may produce mosaic shaped distortion.
- When you record a tape in SP and LP modes, or LP mode only, the playback picture may be distorted or the time code may not be written properly if there is a gap between scenes.
- Record using SP mode for best picture and sound quality.

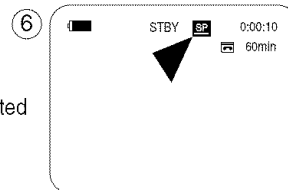
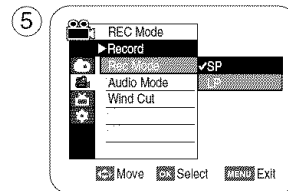
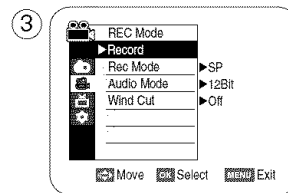

The Camcorder : Advanced Recording

Selecting Audio Mode

- ❖ The Audio Mode function works in both REC and PLAY modes.
- ❖ This Camcorder records sound in two ways. (12Bit, 16Bit)
 - 12Bit: You can record two 12Bit stereo sound tracks.
The original stereo sound can be recorded onto the Main (Sound1) track.
Additional stereo sound can be dubbed onto the Sub (Sound2) track.
 - 16Bit: You can record one high quality stereo sound using the 16Bit recording mode.
Audio dubbing is not possible when using this mode.

1. Set the **Power** switch to **REC** or **PLAY**.
2. Press the **MENU** button.
 - The menu list will appear.
3. Move the **Joystick** up or down to select **Record**, then press the **Joystick(OK)**.
4. Move the **Joystick** up or down to select **Audio Mode**, then press the **Joystick(OK)**.
5. Move the **Joystick** up or down to select desired audio mode (**12Bit** or **16Bit**), then press the **Joystick(OK)**.
6. To exit, press the **MENU** button.

[Note]

When 12Bit is selected, no 12Bit indication will be displayed on the screen.

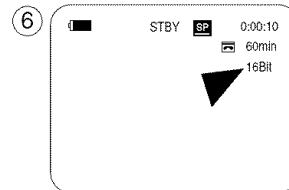
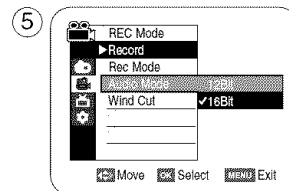
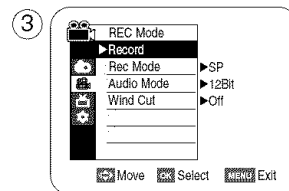

The Camcorder : Advanced Recording

Cutting Off Wind Noise (Wind Cut)

- ❖ The Wind Cut function works in both REC and PLAY (Audio dubbing) modes.
- ❖ Use the Wind Cut function when recording in windy places such as the beach or near buildings.
- ❖ The Wind Cut function minimizes wind noise or other noise while recording.
 - When the wind cut is on, some low pitched tones are eliminated along with the sound of the wind.

1. Set the **Power** switch to **REC** or **PLAY**.
2. Press the **MENU** button.
3. Move the **Joystick** up or down to select **Record**, then press the **Joystick(OK)**.
4. Move the **Joystick** up or down to select **Wind Cut**, then press the **Joystick(OK)**.
5. To activate the Wind Cut function, move the **Joystick** up or down to select **On**, then press the **Joystick(OK)**.
 - Wind Cut ([P]) icon will be displayed.
6. To exit, press the **MENU** button.

[Note]

Make sure Wind Cut is set to off when you want the microphone to be as sensitive as possible.

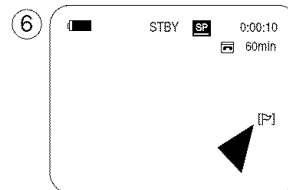
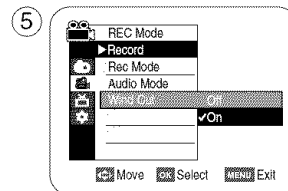
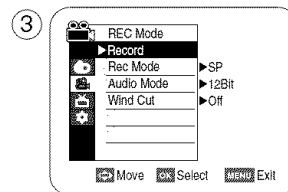

The Camcorder : Advanced Recording

Setting the Shutter Speed & Exposure

- ❖ The Shutter Speed and Exposure function works only in REC mode.
 - ❖ Quick menu is used to access Camcorder functions by simply using the Quick menu selector.
1. Set the **Power** switch to **REC**.
 2. Press the **Quick menu selector**.
 - Quick menu list will appear.
 3. Move the **Quick menu selector** up or down to select **Shutter** or **Exposure**, then press the **Quick menu selector**.
 4. Move the **Quick menu selector** up or down to select **Manual**, then press the **Quick menu selector**.
 5. Move the **Quick menu selector** up or down to select desired shutter speed or exposure, then press the **Quick menu selector**.
 - Shutter speed can be set to **1/60**, **1/100**, **1/250**, **1/500**, **1/1000**, **1/2000**, **1/4000** or **1/10000**.
 - Exposure value can be set between **00** and **29**.
 7. To exit, press the **MENU** button.
 - Selected settings are displayed.

Recommended Shutter Speeds when Recording

- ❖ Outdoor sports such as golf or tennis: 1/2000 or 1/4000
- ❖ Moving cars or trains or other rapidly moving vehicles such as roller coasters: 1/1000, 1/500 or 1/250
- ❖ Indoor sports such as basketball: 1/100

[Notes]

- If you manually change the Shutter Speed and the Exposure value when Program AE option is selected, manual changes are applied first.
- The image may not seem as smooth when a high Shutter Speed is set.
- The Camcorder returns to the auto shutter and auto exposure settings when you change to the EASY.Q mode.
- When recording with a Shutter Speed of 1/1000 or higher, make sure the sun is not shining into the lens.

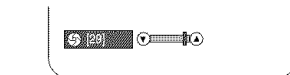
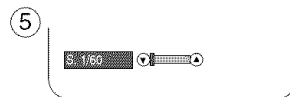
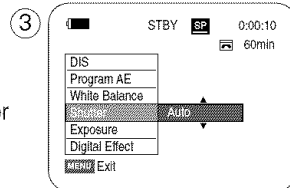
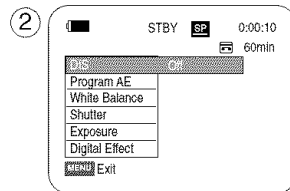
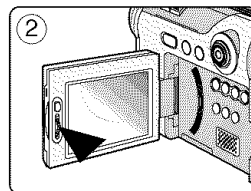

The Camcorder : Advanced Recording

Auto Focus/Manual Focus

- ❖ The Auto Focus/Manual Focus function works only in REC mode.
- ❖ In most situations, it is better to use the automatic focus feature, as it enables you to concentrate on the creative side of your recording.
- ❖ Manual focusing may be necessary under certain conditions that make automatic focusing difficult and/or unreliable.
Manual Focus can be set in the Quick Menu.

Auto Focusing

- ❖ If you are inexperienced in the use of Camcorders, we recommend that you make use of Auto Focus.

Manual Focusing

- ❖ In the following situations, you may obtain better results by adjusting the focus manually.

- A picture containing several objects, some close to the Camcorder, others further away.
- A person enveloped in fog or surrounded by snow.
- Very shiny or glossy surfaces like a car.
- People or objects moving constantly or quickly like an athlete or a crowd.

1. Set the **Power** switch to **REC**.
2. Press the **MF/AF** button.
 - Manual Focus (MF) icon will blink.
3. Move the **Quick menu selector** up or down until the object is in focus.

[Note]

Manual Focus is not available in the EASY.Q mode.

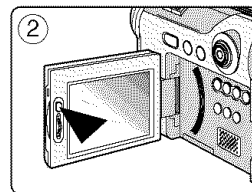
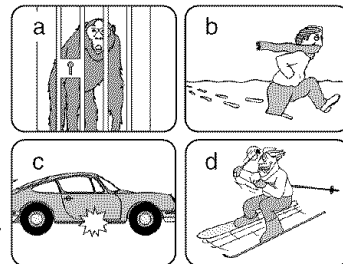

The Camcorder : Advanced Recording

Setting the White Balance

- ❖ The White Balance function works only in REC mode.
- ❖ The White Balance is a recording function that preserves the unique image color of the object in any recording condition.
- ❖ You may select the appropriate White Balance mode to obtain good quality image color.
 - Auto (A): This mode is generally used to control the White Balance automatically.
 - Hold (H): This holds the current White Balance value.
 - Indoor (I): This controls the White Balance according to the indoor ambience.
 - Under halogen or studio/video lighting
 - Subject is of one dominant color
 - Close up
 - Outdoor (O): This controls the White Balance according to the outdoor ambience.
 - In daylight, especially for close up and where the subject is of one dominant color.

1. Set the **Power** switch to **REC**.
2. Press the **MENU** button.
 - The menu list will appear.
3. Move the **Joystick** up or down to select **Camera**, then press the **Joystick(OK)**.
4. Move the **Joystick** up or down to select **White Balance**, then press the **Joystick(OK)**.
5. Move the **Joystick** up or down to select desired mode (**Auto**, **Hold**, **Indoor** or **Outdoor**), then press the **Joystick(OK)**.
6. To exit, press the **MENU** button.
 - When the Auto mode is selected, no icon will be displayed.
 - The selected icon will be displayed.

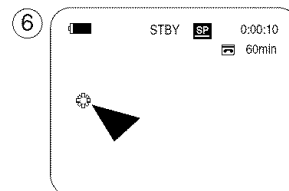
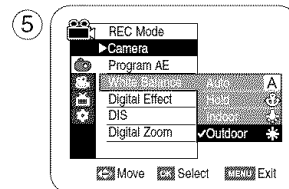
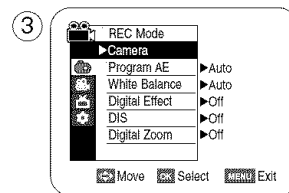

The Camcorder : Advanced Recording

Using Quick Menu: White Balance

- ❖ Quick menu provides easier access to frequently used menus without using the MENU button.
1. Press the **Quick menu selector**.
 2. Move the **Quick menu selector** up or down to select **White Balance**, then press the **Quick menu selector**.
 3. Move the **Quick menu selector** up or down to select desired mode (**Auto, Hold, Indoor or Outdoor**), then press the **Quick menu selector**.
 4. To exit, press the **MENU** button.

[Notes]

- The White Balance function will not operate in EASY.Q mode.
- Turn the Digital Zoom off (if necessary) to set a more accurate white balance.
- Reset the white balance if lighting conditions change.
- During normal outdoor recording, setting to Auto may provide better results.

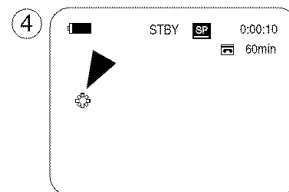
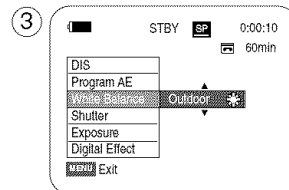
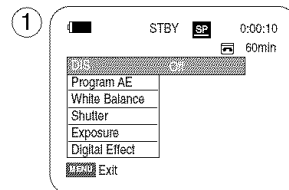

The Camcorder : Advanced Recording

Setting the Digital Image Stabilizer (DIS)

- ❖ The DIS function works only in REC mode.
- ❖ DIS (Digital Image Stabilizer) is a function that compensates for any shaking or hand movement while holding the Camcorder (within reasonable limits).
- ❖ It provides more stable pictures when:
 - Recording with the zoom (DIS is not available in Digital Zoom mode.)
 - Recording a small object close-up
 - Recording and walking at the same time
 - Recording through the window of a vehicle

1. Set the **Power** switch to **REC**.
2. Press the **MENU** button.
 - The menu list will appear.
3. Move the **Joystick** up or down to select **Camera**, then press the **Joystick(OK)**.
4. Move the **Joystick** up or down to select **DIS**, then press the **Joystick(OK)**.
5. To activate the DIS function, move the **Joystick** up or down to select **On**, then press the **Joystick(OK)**.
 - If you do not want to use the DIS function, set the DIS menu to **Off**.
6. To exit, press the **MENU** button.
 - DIS () icon is displayed.

[Notes]

- Digital Zoom, Color Nite, Mosaic, Mirror, Emboss2, Pastel2 or 16:9 Wide is not available in the DIS mode.
- When you press the PHOTO button while the DIS function is enabled, the DIS will be released shortly and resume automatically after the photo recording.

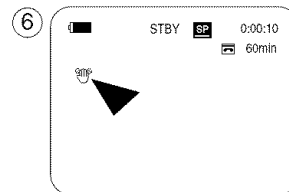
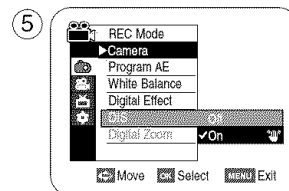
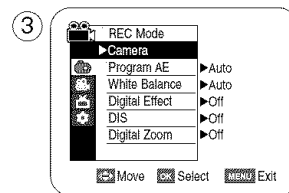

The Camcorder : Advanced Recording

Using Quick Menu: Digital Image Stabilizer (DIS)

- ❖ Quick menu provides easier access to frequently used menus without using the MENU button.

1. Press the **Quick menu selector**.
2. Move the **Quick menu selector** up or down to select **DIS**, then press the **Quick menu selector**.
3. Move the **Quick menu selector** up or down to select **On** or **Off**, then press the **Quick menu selector**.
4. To exit, press the **MENU** button.

[Notes]

- It is recommended that you deactivate the DIS function when using a tripod.
- If you use the DIS function, the picture quality may deteriorate.
- EASY.Q mode automatically sets the DIS to On.

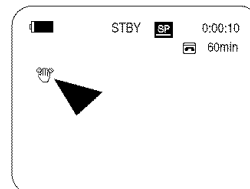
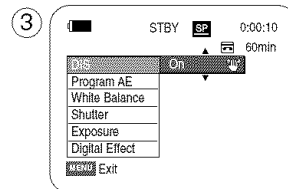
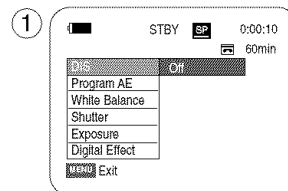

The Camcorder : Advanced Recording

Programmed Automatic Exposure Modes (Program AE)

- ❖ The Program AE function works only in REC mode.
 - ❖ The Program AE mode allows you to adjust shutter speeds and apertures to suit different recording conditions.
 - ❖ They give you creative control over the depth of field.
- **Auto mode** (A)
 - Auto balance between the subject and the background.
 - To be used in normal conditions.
 - The shutter speed automatically varies from 1/60 to 1/250 per second, depending on the scene.
 - **Sports mode** (S)
 - For recording people or objects moving quickly.
 - **Portrait mode** (P)
 - For focusing on the background of the subject, when the background is out of focus.
 - The Portrait mode is most effective when used outdoors.
 - The shutter speed automatically varies from 1/60 to 1/1000 per second.
 - **Spotlight mode** (S)
 - For recording correctly when there is only light on the subject and not the rest of the picture.
 - **Sand/Snow mode** (S)
 - For recording when people or objects are darker than the background because of reflected light from sand or snow.
 - **High Speed(High Shutter Speed) mode** (S)
 - For recording fast-moving subjects such as players in golf or tennis games.

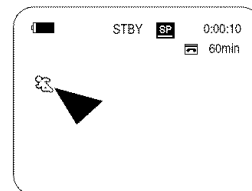

[Note]

The Program AE function will not operate in EASY.Q mode.

The Camcorder : Advanced Recording

Setting the Program AE

1. Set the **Power** switch to **REC**.
2. Press the **MENU** button.
 - The menu list will appear.
3. Move the **Joystick** up or down to select **Camera**, then press the **Joystick(OK)**.
4. Move the **Joystick** up or down to select **Program AE**, then press the **Joystick(OK)**.
 - The available options are listed.
5. Move the **Joystick** up or down to select desired program AE option, then press the **Joystick(OK)**.
6. To exit, press the **MENU** button.
 - The icon of the selected mode will be displayed.
 - When the Auto mode is selected, no icon will be displayed.

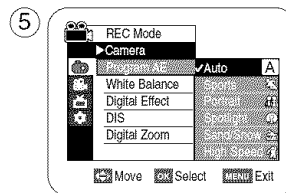
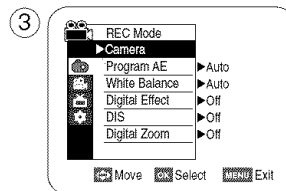

Using Quick Menu: Program AE

1. Press the **Quick menu selector**.
2. Move the **Quick menu selector** up or down to select **Program AE**, then press the **Quick menu selector**.
3. Move the **Quick menu selector** up or down to select desired program AE option, then press the **Quick menu selector**.
4. To exit, press the **MENU** button.

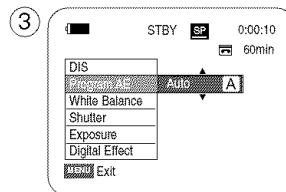
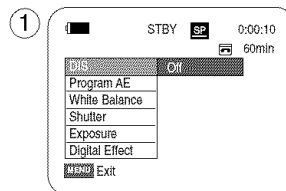

The Camcorder : Advanced Recording

Applying Digital Effects

- ❖ The Digital Effect function works only in REC mode.
- ❖ The Digital Effects enable you to give a creative look to your recording.
- ❖ Select the appropriate Digital Effect for the type of picture that you wish to record and the effect you wish to create.
- ❖ There are 11 Digital Effect modes.

1. Art mode

This mode gives the images a coarse effect.

2. Mosaic mode

This mode gives the images a mosaic effect.

3. Sepia mode

This mode gives the images a reddish-brown pigment.

4. Negative mode

This mode reverses the colors, creating a negative image.

5. Mirror mode

This mode cuts the picture in half, using a mirror effect.

6. BLK & WHT mode

This mode changes the images to black and white.

7. Emboss1 mode

This mode creates a 3D effect (embossing).

8. Emboss2 mode

This mode creates a 3D effect (embossing) on surrounding area of an image.

9. Pastel1 mode

This mode applies a pale pastel drawing effect to an image.

10. Pastel2 mode

This mode applies a pale pastel drawing effect to surrounding area of an image.

11. 16:9 Wide mode

Select to record a picture to be played back on a 16:9 Wide TV.

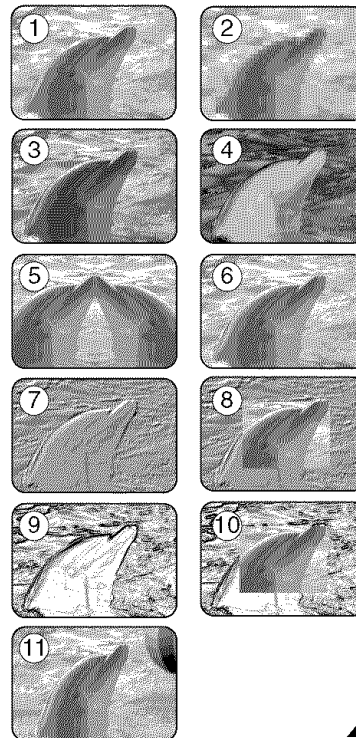

The Camcorder : Advanced Recording

Selecting the Digital Effects

1. Set the **Power** switch to **REC**.
2. Press the **MENU** button.
 - The menu list will appear.
3. Move the **Joystick** up or down to select **Camera**, then press the **Joystick(OK)**.
4. Move the **Joystick** up or down to select **Digital Effect**, then press the **Joystick(OK)**.
5. Move the **Joystick** up or down to select the desired Digital Effect mode, then press the **Joystick(OK)**.
 - The display mode is set to the selected mode.
6. To exit, press the **MENU** button.

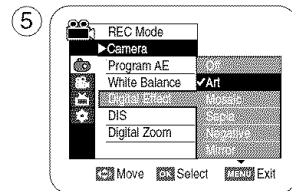
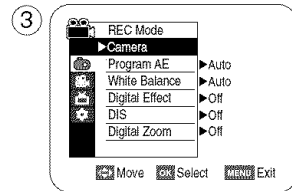
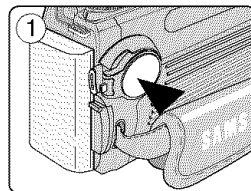

[Notes]

- The Mosaic, Mirror, Emboss2, Pastel2 and 16:9 Wide modes are not available while DIS or Color Nite is in use.
- Digital Effect modes are not available while EASY.Q is in use.
- Once DIS, EASY.Q or Color Nite is set, Mosaic, Mirror, Emboss2, Pastel2 or 16:9 Wide modes will be released.
- Digital Zoom is not available in the Mosaic, Mirror, Emboss2, Pastel2 and 16:9 Wide modes.
- Digital Effect modes other than Mosaic, Mirror, Emboss2, Pastel2 and 16:9 Wide modes are available while DIS is in use.
- Photo image recording is not available in the 16:9 Wide mode.

The Camcorder : Advanced Recording

Using Quick Menu: Digital Effects

- ❖ Quick menu is used to access Camcorder functions by using the Quick menu selector.
- ❖ Quick menu provides easier access to frequently used menus without using the MENU button.

1. Press the **Quick menu selector**.
2. Move the **Quick menu selector** up or down to select **Digital Effect**, then press the **Quick menu selector**.
3. Move the **Quick menu selector** up or down to select the desired Digital Effect mode, then press the **Quick menu selector**.
4. To exit, press the **MENU** button.

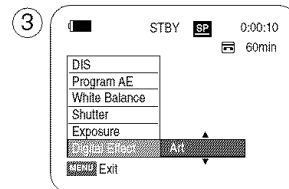
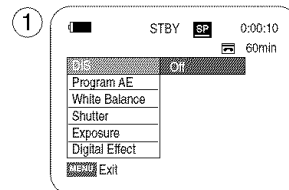

The Camcorder : Advanced Recording

Zooming In and Out with Digital Zoom

- ❖ Digital Zoom function works only in REC mode.

Selecting the Digital Zoom

- ❖ Zooming more than 10x is achieved digitally, up to 900x when combined with optical zoom.
- ❖ The picture quality may deteriorate depending on how much you zoom in on the subject.

1. Set the **Power** switch to **REC**.
2. Press the **MENU** button.
 - The menu list will appear.
3. Move the **Joystick** up or down to select **Camera**, then press the **Joystick(OK)**.
4. Move the **Joystick** up or down to select **Digital Zoom**, then press the **Joystick(OK)**.
5. Move the **Joystick** up or down to select desired zoom mode (**Off**, **100x**, **200x**, **400x** or **900x**), then press the **Joystick(OK)**.
6. To exit, press the **MENU** button.

[Notes]

- Maximum zooming may result in lower picture quality.
- Digital Zoom is not available while DIS, EASY.Q, photo image recording, Color Nite, Mosaic, Mirror, Emboss2, Pastel2 or 16:9 Wide is in use.
- Once photo image recording, Color Nite, Mosaic, Mirror, Emboss2, Pastel2 or 16:9 Wide is set, Digital Zoom mode will be released. (The Digital Zoom mode will be backed up.)
- Once DIS or EASY.Q is set, Digital Zoom mode will be released.

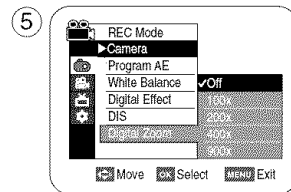
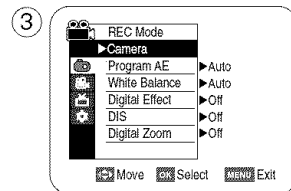
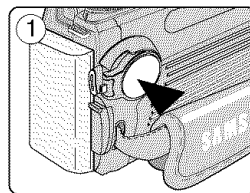

The Camcorder : Advanced Recording

Photo Image Recording

- ❖ Photo image recording works only in REC mode.
 1. Set the **Power** switch to **REC**.
 2. Press the **PHOTO** button.
 - The still picture is recorded for about 6~7 seconds.
 3. After the PHOTO has been recorded, the Camcorder returns to STBY mode.

Searching for a Photo Image

- ❖ The Photo Search works only in PLAY mode.
- ❖ You can use photo searching by using the PHOTO SEARCH button on the remote control.

1. Set the **Power** switch to **PLAY**.
2. Press the **MENU** button.
 - The menu list will appear.
3. Move the **Joystick** up or down to select **Tape**, then press the **Joystick(OK)**.
4. Move the **Joystick** up or down to select **Photo Search**, then press the **Joystick(OK)**.
5. Press the **◀/▶**(REW/FF) buttons to select the photo.
 - The photo search process appears on LCD screen while you are searching.
 - After completing the search, the Camcorder displays the still image.
6. To exit, press the **■** (STOP) or **MENU** button.

[Notes]

- Photo image recording is not available while recording.
- You can use photo image recording by using the PHOTO button on the remote control. Pressing the PHOTO button on the remote control records the still image at once with automatic focusing.
- When there are no still images recorded on the tape, it will be fully rewound or forwarded.
- Photo image recording is not available while Color Nite or 16:9 Wide is in use.
- DIS, Digital Zoom, Color Nite and Digital Effect are not available, when photo image recording.
- Photo image recording while EASY.Q, DIS or Digital Zoom mode is in use will release current mode. (After a photo image is taken, the mode will return automatically.)

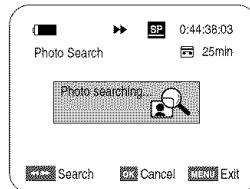
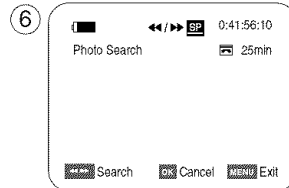
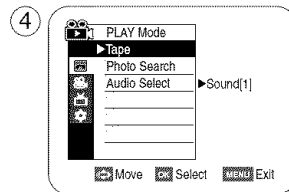
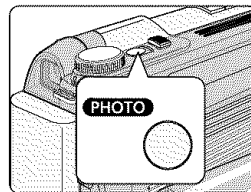

The Camcorder : Playback

Playing Back a Tape You have recorded on the LCD Screen

- ❖ The Playback function works only in PLAY mode.
- ❖ You can monitor the playback picture on the LCD screen.

1. Set the **Power** switch to **PLAY**.
2. Insert the tape you wish to view. (see page 38)
3. Open the LCD screen.
 - Adjust the angle of the LCD screen and set the brightness or color if necessary.
4. Press the ◀◀ (REW) button to rewind the tape to the starting point.
 - To stop rewinding, press the ■ (STOP) button.
 - The Camcorder stops automatically after rewinding is complete.
5. Press the ▶▶ (PLAY/STILL) button to start playback.
 - You can view the picture you recorded on the LCD screen.
 - To stop playback, press the ■ (STOP) button.

Adjusting the LCD Bright/Color during Playback

- ❖ You can adjust the LCD Bright/Color during playback.
- ❖ The adjustment method is the same procedure as used in REC mode. (see page 34)

[Notes]

- You can also view the picture on a TV screen, after connecting the Camcorder to a TV or VCR. (see pages 70~71)
- Various functions are available in PLAY mode. (see pages 72~73)
- For searching and viewing still images recorded onto tape. (see page 67)

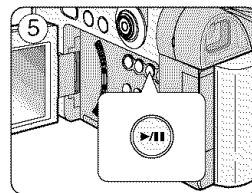
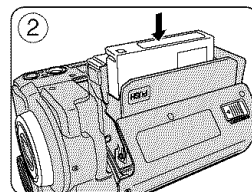
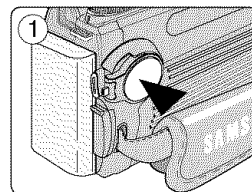

The Camcorder : Playback

Controlling Sound from the Speaker

- ❖ The Speaker works only in PLAY mode.
- ❖ When you use the LCD screen for playback, you can hear recorded sound from the built-in Speaker.
 - Take the following steps to lower the volume or mute the sound while playing a tape on the Camcorder.

1. Set the **Power** switch to **PLAY**.
2. Press the **▶/II** (PLAY/STILL) button to play the tape.
3. When you hear sounds once the tape is in play, use the **Quick menu selector** to adjust the volume.
 - A volume level display will appear on the LCD screen. Levels may be adjusted from anywhere between 00 to 19 and you will not hear any sound when the volume level is set on 00.
 - If you close the LCD screen while playing, you will not hear sound from the speaker.

[Notes]

- When the Multi-AV cable is connected to the Camcorder, you cannot hear sound from the Built-In Speaker and cannot adjust the volume.
- The sound will return when you remove the connected Multi-AV cable from the jack of your Camcorder.

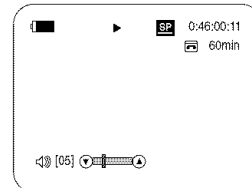
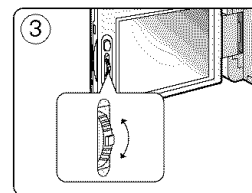
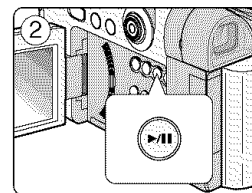

The Camcorder : Playback

Tape Playback

- ❖ The Playback function works only in PLAY mode.

Playback on the LCD Screen

- ❖ It is practical to view a tape using the LCD screen when in a car or outdoors.

Playback on a TV Monitor

- ❖ To play back a tape, the television must be NTSC compatible. (see page 146)
- ❖ We recommend that you use the AC Power adapter as the power source for the Camcorder.

Connecting to a TV which has Audio/Video Input Jacks

1. Connect the Camcorder to your TV with the Multi-AV cable.
 - The yellow jack: Video
 - The white jack: Audio(L)-mono
 - The red jack: Audio(R)

If you connect to a monaural TV, connect the yellow jack (Video) to the video input of the TV and the white jack (Audio L) to the audio input of the TV.
2. Set the **Power** switch to **PLAY**.
3. Turn on the TV and set the TV/VIDEO selector on the TV to Video.
 - Refer to the TV user's manual.
4. Play the tape.

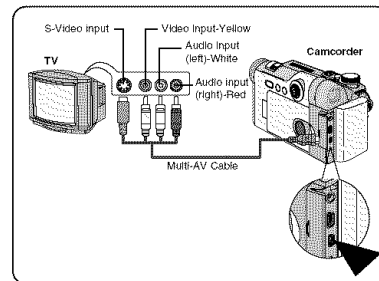

[Notes]

- You may use an S-Video cable to obtain better quality pictures if you have a S-Video jack on your TV.
- Even if you use an S-Video cable, you need to connect an audio cable.
- If you connect the cable to the AV/S-Video jack, you will not hear sound from the Camcorder's speakers.
- If only a mono audio input is available on the TV set, use the audio cable with the white jack (Audio L).

The Camcorder : Playback

Connecting to a TV which has no Audio and Video Input Jacks

- ❖ You can connect your Camcorder to a TV through a VCR.
 1. Connect the Camcorder to your VCR with the Multi-AV cable.
 - The yellow jack: Video
 - The white jack: Audio(L) - Mono
 - The red jack: Audio(R)
 2. Connect a TV to the VCR.
 3. Set the **Power** switch to **PLAY**.
 4. Turn on both the TV and VCR.
 - Set the input selector on the VCR to Line.
 - Select the channel reserved for your VCR on the TV set.
 5. Play the tape.

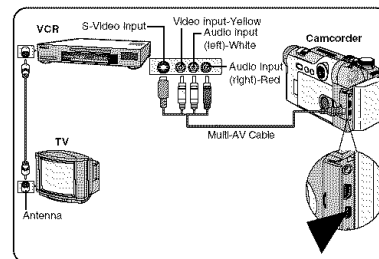

Playback

- ❖ You can play the recorded tape in PLAY mode.
 1. Connect a power source and set the **Power** switch to **PLAY**.
 2. Insert the tape you wish to play back.
 3. Using the ◀◀/▶▶ (REW/FF) buttons, find the first position you wish to play back.
 4. Press the ▶/II (PLAY/STILL) button.
 - The images you recorded will appear on the TV after a few seconds.
 - If a tape reaches its end while being played back, the tape will rewind automatically.

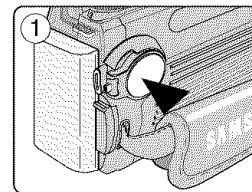

[Notes]

- The playback mode (SP/LP) is determined by the mode in which the tape was recorded.
- If the VCR has an S-Video input jack, you may use S-Video for better quality.
- The S-Video jack transmits video only. Connect audio cables for sound.
- If only a mono audio input is available on the TV set, use the audio cable with the white jack(Audio L).

The Camcorder : Playback

Various Functions in PLAY Mode

- ❖ This function works only in PLAY mode.
- ❖ The PLAY, STILL, STOP, FF, REW buttons are located on the Camcorder and the remote control.
- ❖ The F.ADV (Frame advance), X2, SLOW buttons are located on the remote control only.
- ❖ To prevent tape and head-drum wear, your Camcorder will automatically stop if it is left in still or slow modes for more than 3 minutes.

Playback Pause

- Press the ►/II (PLAY/STILL) button during playback.
- To resume playback, press the ►/II (PLAY/STILL) button.

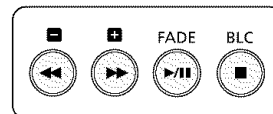

Picture Search (Forward/Reverse)

- Press the ◀◀/▶▶ (REW/FF) buttons during playback or still mode.
To resume normal playback, press the ►/II (PLAY/STILL) button.
- Keep pressing ◀◀/▶▶ (REW/FF) buttons during playback or still mode.
To resume normal playback, release the button.

Slow Playback (Forward/Reverse)

- Forward Slow playback
 - Press the **SLOW** button on the remote control during playback.
 - To resume normal playback, press the ►/II (PLAY/STILL) button.
- Reverse Slow Playback
 - Press the ◀III (-) button during forward slow play back.
 - To resume forward slow playback, press the III▶ (+) button.
 - To resume normal playback, press the ►/II (PLAY/STILL) button.

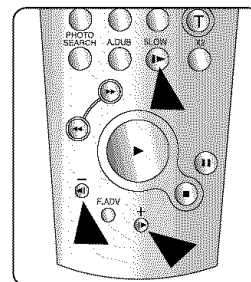

The Camcorder : Playback

Frame Advance (To play back frame by frame)

- Press the **F.ADV** button on the remote control in still mode.
 - Video sequence advances frame by frame each time you press the **F.ADV** button.
 - The F.ADV function works in still mode only.
- To resume normal playback, press the **▶/II** (PLAY/STILL) button.
 - Forward frame advance
Press the **F.ADV** button on the remote control in still mode.
 - Reverse frame advance
Press the **◀II (-)** button on the remote control to change the direction in F.ADV mode.
Press the **F.ADV** button on the remote control.

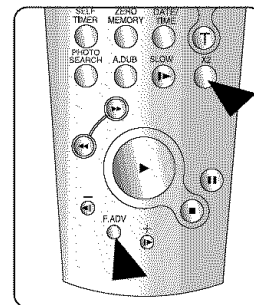

X2 Playback (Forward/Reverse)

- Forward X2 playback
 - Press the **X2** button on the remote control during playback.
 - To resume normal playback, press the **▶/II** (PLAY/STILL) button.
- Reverse X2 playback
 - Press the **◀II (-)** button during forward X2 playback.
 - To resume normal playback, press the **▶/II** (PLAY/STILL) button.

Reverse Playback

- To playback in reverse at normal speed, press the **◀II (-)** button during normal forward playback.
- Press the **▶/II** (PLAY/STILL) or **II▶ (+)** button to return to normal forward playback.

[Notes]

- Mosaic shaped distortion may appear on the screen while in some of the various playback modes. Mosaic shaped distortion or noise may be experienced when you play back tapes recorded in LP which contain various playback functions.
- Sound will only be heard during normal SP or LP playback.

The Camcorder : Playback

Audio Dubbing

- ❖ The Audio Dubbing function works only in PLAY Mode.
- ❖ You can not dub sound on a pre-recorded tape in LP or 16 bit mode.
- ❖ You can add sound to the original sound on a pre-recorded tape recorded in SP mode with 12bit sound.
- ❖ Use the internal or an external microphone(not supplied) or other audio equipment.
- ❖ The original sound will not be erased.

Dubbing Sound

1. Set the **Power** switch to **PLAY**.
 - If you want to use an external microphone, connect the microphone to the external MIC input jack on the Camcorder.
2. Press the ►/II (PLAY/STILL) button and find the time frame of the scene to be dubbed.
3. Press the ►/II (PLAY/STILL) button to pause the scene.
4. Press the **A.DUB** button on the remote control.
 - Audio Dubbing icon (🗣️) will be displayed.
 - The Camcorder is ready for dubbing.
5. Press the ►/II (PLAY/STILL) button to start dubbing.
 - Press the ■ (STOP) button to stop the dubbing.

[Notes]

- You can not use the Audio Dubbing function while playing a write protected video tape.
- To utilize an external MIC or sound source, connect a microphone to the MIC jack or use the Multi-AV cable to connect external sound source input.

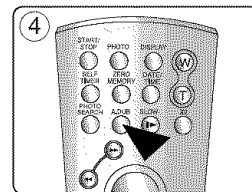
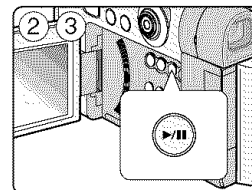
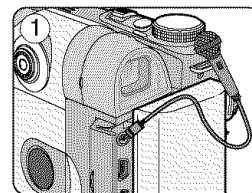

The Camcorder : Playback

Dubbed Audio Playback

1. Set the **Power** switch to **PLAY**.
2. Insert the dubbed tape and press the **MENU** button.
3. Move the **Joystick** up or down to select **Tape**, then press the **Joystick(OK)**.
4. Move the **Joystick** up or down to select **Audio Select**, then press the **Joystick(OK)**.
5. Move the **Joystick** up or down to select the audio playback channel, then press the **Joystick(OK)**.
 - Sound[1]: play the original sound.
 - Sound[2]: play the dubbed sound.
 - MIX[1+2]: play back sound1 and 2 equally mixed.
6. To exit, press the **MENU** button.
7. Press the **▶/II** (PLAY/STILL) button to playback the dubbed tape.

[Note]

When you playback added sound (Sound 2 or MIX mode), you may experience a loss of sound quality.

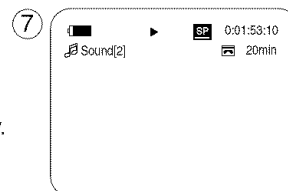
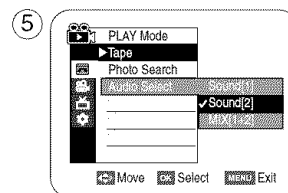
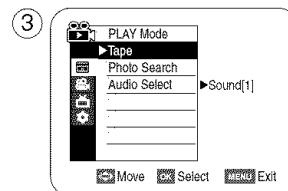

IEEE 1394 Data Transfer

Transferring IEEE1394 (i.LINK)-DV Standard Data Connections

Connecting to a DV Device (DVD Recorder, Camcorder, etc.)

- Connecting to other DV standard products.
A standard DV connection is quite simple.
If a product has a DV jack, you can transfer data by connecting to the DV jack using the correct cable.
NOTE: Please be careful since there are two types of DV jacks, (4pin, 6pin). This Camcorder has a 4pin jack.
- With a digital connection, video and audio signals are transmitted in digital format, allowing high quality images to be transferred.

Connecting to a PC

- If you want to transmit data to a PC, you must install an IEEE 1394 add-on card into the PC. (not supplied)
- The frame rate for video capture is dependent on the capacity of the PC.

[Notes]

- When you transmit data from the Camcorder to another DV device, some functions may not work.
If this occurs, please reconnect the DV cable or turn the power OFF and ON again.
- When you transmit data from the Camcorder to PC, PC function button is not available in  (Play) mode.
- Do not use the Camcorder and IEEE1394 together as this will cause IEEE1394 to shut off.
- Do not connect the Camcorder to a PC using both DV and USB cables. It may not operate properly.
- Operation is not guaranteed for all computer environments recommended above.
- The IEEE1394 cable (DV cable) is sold separately.
- Video Capture software is commercially available.
- Most DV enabled PCs have a 6 pin jack. In this case, a 6pin/4pin cable is required for the connection.
- Most DV enabled Notebooks and Laptops have a 4 pin jack. Use a 4pin/4pin cable for the connection.
- DIS and Color Nite are not available in DV (IEEE1394) mode.

IEEE 1394 Data Transfer

System Requirements

- CPU: faster Intel® Pentium III™ 450MHz compatible.
- Operating system: Windows® 98SE, ME, XP, Mac OS (9.1~10.2)
- Main memory: more than 64 MB RAM
- IEEE1394 add-on card or built in IEEE1394 card

Recording with a DV Connection Cable

1. Set the **Power** switch to **PLAY**.
2. Connect the DV cable (not supplied) from the DV jack of the Camcorder to the DV jack of the other DV device.
 - Make sure that **DV** is displayed on the LCD screen.
3. Press the **Start/Stop** button to begin **REC PAUSE** mode.
 - **PAUSE** is displayed on the LCD screen.
4. Start playback on the other DV device while you monitor the picture.
5. Press the **Start/Stop** button to start recording.
 - If you want to pause recording momentarily, press the **Start/Stop** button again.
6. To stop recording, press the **■** (STOP) button.

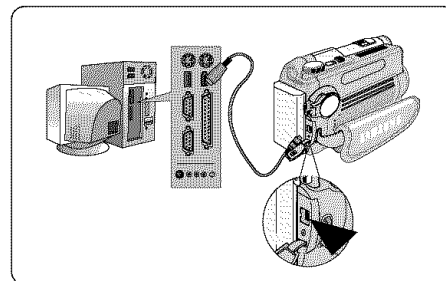

[Notes]

- When using this Camcorder as a recorder, the pictures that appear on a monitor may seem uneven, however recorded pictures will not be affected.
- Operation is not guaranteed for all the recommended computer environments mentioned above.

USB Interface

Transferring a Digital Image through a USB Connection

- ❖ The camcorder supports both USB 1.1 and 2.0 standards. (Depends on the PC specification)
- ❖ You can easily transfer a image from a Memory card to a PC without additional add-on cards via a USB connection.
- ❖ You can transfer a recorded file in memory card to a PC via a USB connection.
- ❖ If you transfer data to a PC, you need to install the software (DV Driver, Video Codec , DirectX 9.0) supplied with the Camcorder.

USB Connection speed depending on the System

High speed USB connection is supported by Microsoft (Windows) device drivers and Apple's Mac OS X.

- Windows 98SE/ME - Full Speed USB
- Windows 2000 - High speed USB on a system with Service Pack 4 or later installed.
- Windows XP - High speed USB on a system with Service Pack 1 or later installed.
- Mac OS X - High speed USB on a system with 10.3. or later installed. (Only in CAMERA mode)



System Requirements

	Windows Environment		Macintosh Environment	
	Minimum	Recommended	Minimum	Recommended
CPU	Pentium III, 600MHz	Pentium 4, 2GHz	G3 500MHz	G4 Processor
OS	Windows 98SE/ME	Windows 2000/XP	Mac OS 10.2	Mac OS 10.3
Memory	128MB	512MB	128MB	512MB or above
HDD Capacity	1GB or more	2GB or more	200MB (For applications only. Apart from this, 1GB or more free space)	2GB or above
Resolution	1024 x 768 dots 24-bit Color	1024 x 768 dots 24-bit Color	800 x 600 dots 16-bit color	1024 x 768 dots 24-bit color
USB	USB1.1	USB2.0 High Speed	USB 1.1	USB 2.0 High Speed

[Notes]

- USB 2.0 works only for removable disk functions.
- On a slower PC than recommended, movie playback may not be smooth or video editing may take a long time.
- On a slower PC than recommended, movie playback may skip frames or operate unexpectedly.
- Intel® Pentium III™ or Pentium 4™ is a trademark of the Intel Corporation.
- Mac, Macintosh and Mac OS are trademarks of Apple Computer, Inc.
- Windows® is a registered trademark of the Microsoft® Corporation.
- All other brands and names are property of their respective owners.
- Operations are not guaranteed for all of the recommended computer environments mentioned above.
- Do not connect the Camcorder to a PC using both DV and USB cables. It may not operate properly.
- In CAMERA mode, be sure that the Memory card is inserted into Camcorder before connecting USB cable.
If no Memory card or an unformatted Memory card is inserted, PC will not recognize your Camcorder as a removable disk.
- USB Streaming requires Video Codec, DV Driver and DirectX 9.0.
- If you disconnect the USB cable from the PC or the Camcorder during the data transfer, the data transfer will stop and the data may be damaged.
- If you connect the USB cable to a PC using a USB HUB or with other devices at the same time, it may cause conflict and may not work properly.
- If this occurs, remove all other USB devices and try the connection again.

USB Interface

Installing DV Media Pro 1.0 Program

- ❖ To play back MPEG moving pictures recorded by the camcorder or streaming data transferred through the USB connection on a PC, the Video Codec program should be installed.
- ❖ Do not connect the Camcorder to PC before installing the program.
- ❖ If another Camcorder or scanner is connected, please disconnect it in advance.
- ❖ DV Media Pro User's Manual is included on the accompanying CD(D:\help\) in Adobe's Portable Document Format(PDF) The user's manual can be viewed using Acrobat Reader software, which is also included on the CD (D:\Support\AcrobatReader\AcroReader51_ENU_full.exe). (The Acrobat Reader is a freeware product of AdobeSystems,Inc.)
- ❖ DV Media Pro User's Manual is in English.

Program Installation

1. Insert the software CD into the CD-ROM drive of your computer.
Installation selection screen appears on the monitor.
2. If the installation selection screen does not appear after inserting the CD, click "Run" in the Windows "Start" menu and execute Autorun.exe file to begin installation.
When CD-ROM drive is set to "D:drive", type "D:\autorun.exe" and press Enter.
3. Click the icons listed below to install the selected software.
 - DV Driver Click
 - USB removable Disk Driver (Windows®98SE only)
 - USB PC CAMERA & STREAMING Driver (CAPTURE DRIVER)
 - Connect a Camcorder to your PC to complete the DV Driver installation.
 - 1) Set the camcorder **Power** switch to **REC**.
 - 2) Connect the camcorder to the PC using the USB cable.
 - 3) The SAMSUNG A/V Capture driver installation begins on the PC.
 - DirectX 9.0 Click
 - Video Codec Click
The Video Codec needs to be installed in order to play back the MPEG4 Movies (stored in the Memory Card) on a PC or to use the USB Streaming/PC Camera functions.

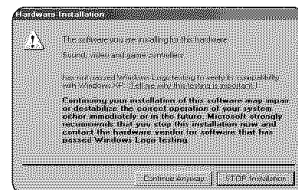
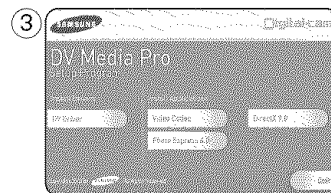

[Note]

If a message saying "Digital Signature not found" or something similar appears, ignore the message and continue with the installation.

USB Interface

Using the PC Camera Function

- ❖ To use the PC Camera function, the DV Driver, Video Codec and DirectX 9.0. programs must be installed in the PC.
- ❖ You can use this Camcorder as a PC Camera. This is useful when connecting to a Web site that provides video chatting functions.
- ❖ When using this camcorder for video conferencing (such as NetMeeting), voice communication may not be supported depending on the video conferencing software. In this case, connect an external microphone to the soundcard of the PC to enable voice communication.
- ❖ You can participate in video conferencing by using the Camcorder with PC Net-meeting program installed.
- ❖ The PC CAMERA's screen size (Transferred video frame rate for the PC Camera function is max 15 fps.)
 - 320X240 (QVGA) pixels for USB 1.1 connection.
- ❖ If PC is connected with the USB to the Camcorder, only the Zoom switch operates.

1. Set the **Power** switch to **REC**.
2. Connect one end of the USB cable to the USB jack on the Camcorder and the other end to the USB connector on your computer.

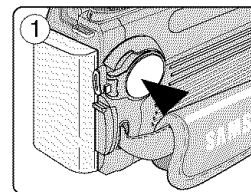

USB Interface

Using the USB Streaming Function

- ❖ To use USB streaming, the DV Driver, Video Codec and DirectX 9.0. programs must be installed in the PC.
 - ❖ You can view Camcorder video on your PC using USB streaming.
 - ❖ You can also store it as a moving picture in the "avi" file format, or as a still image in the "jpg" file format on a PC.
1. Set the **Power** switch to **REC** or **PLAY**.
 2. Connect one end of the USB cable to the USB jack on the Camcorder and the other end to the USB jack on your computer.
 3. Setup and execute Windows Movie Maker or the Ulead VIDEO Studio Software application provided on the CD.
 - For detailed instructions for Ulead VIDEO Studio use, refer to the program's Help function.
 - Windows Movie Maker is used for WINDOWS ME and XP users. (C:\program files\Movie maker\moviemk.exe)

Using the removable Disk Function

- ❖ You can easily transfer data from a Memory card to a PC without additional add-on cards via a USB connection.
1. Set the **Power** switch to **CAMERA**.
 2. Connect one end of the USB cable to the USB jack on the Camcorder and the other end to the USB jack on your computer.
 3. To verify whether the removable disk has been properly recognized, open Windows Explorer and locate the removable disk.

Connecting to a PC

1. Connect a USB cable to the USB jack on the PC.
 - If a USB cable is connected to the Camcorder's USB jack, the audio/video output is disabled.
2. Connect the other end of the USB cable into the USB jack on the Camcorder. (USB jack)
 - If a PC is connected to the Camcorder with a USB cable, only the Zoom switch operates.

Disconnecting the USB Cable

- ❖ After completing the data transmission, you must disconnect the cable in the following way:
1. Select the removable disc icon and click the right mouse button to select [Eject].
 2. Select [Confirm] and disconnect the USB cable when the Windows Splash screen appears.

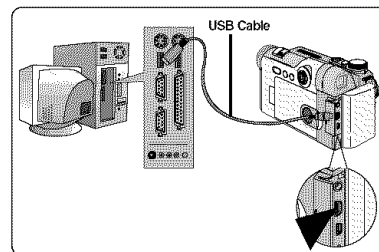

[Notes]

- If you disconnect the USB cable from the PC or the Camcorder while transferring, the data transmission will stop and the data may be damaged.
- If you connect the USB cable to a PC via a USB HUB or simultaneously connect the USB cable along with other USB devices, the Camcorder may not work properly. If this occurs, remove all USB devices from the PC and reconnect the Camcorder.



Digital Still Camera Mode : Preparation

Using the Mode Dial

- ❖ Turn the Mode Dial to select Camera mode by setting the selector as illustrated.
- ❖ Available Camera Modes are:
 -  (Program): Sets aperture and shutter speed automatically for the user's convenience, other settings are free to set by manual
 - SCENE: Preset Automatic Modes that contain predefined settings
 - A: Aperture Priority Mode
 - S: Shutter Speed Priority Mode
 - M: Full Manual Mode, you can customize options to suit your needs
 - MySET: Loads your frequent settings
 -  (Movie): Movie Mode, records moving images into the Memory Card
 -  (Play): Playback Mode (for still image and moving image)

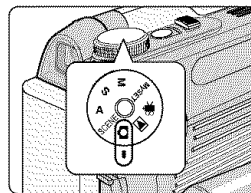

Using the Memory Card

- ❖ MMC, SD, Memory Stick and Memory Stick Pro are compatible.
- ❖ The Memory Card stores and manages still images recorded by the Camcorder.
- ❖ Before inserting or ejecting the Memory Card, set the Power switch to OFF.

Memory Card Functions

- ❖ Recording/Viewing Still Images
- ❖ Protecting Images from accidental erasure (except MMC)
- ❖ Deleting Still Images stored in Memory Card
- ❖ Marking Still Images with Print Information
- ❖ Formatting Memory Cards

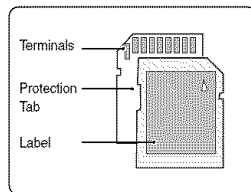
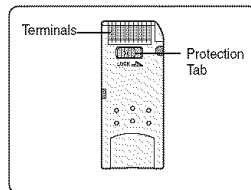

Digital Still Camera Mode : Preparation

Inserting a Memory Card

1. Open the Memory Card Cover.
2. Insert the Memory Card into the Slot until it softly clicks.
3. Close the Memory Card Cover.

Ejecting a Memory Card

1. Open the Memory Card Cover.
2. Slightly push the Memory Card inwards to pop it out.
3. Pull the Memory Card out of the slot and close the Memory Card Cover.

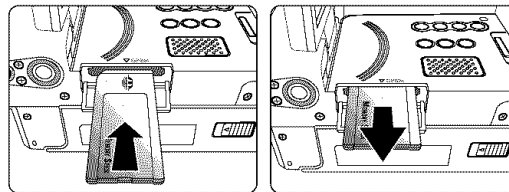

[Notes]

- Do not apply excessive force when you insert/eject the Memory Card.
- Do not turn the power off while recording, loading, erasing still image or formatting the Memory Card.
- Please turn the power off before you insert or eject the Memory Card to avoid losing data.
- Do not place the Memory Card near a strong electro-magnetic device.
- Do not allow metal substances to come in contact with the terminals on the Memory Card.
- Do not bend the Memory Card.
- After pulling the card out from the camcorder, keep the Memory Cards in a soft case to prevent static shock.
- The data stored on the card may be changed or lost as a result of misuse, static electricity, electric noise or repair. Save important images separately.
- Samsung is not responsible for data loss due to misuse.



MEMORY STICK™

- “Memory Stick” and  are trademarks of Sony Corporation.
 - All other product names mentioned herein may be the trademarks or registered trademarks of their respective companies.
- Furthermore, “™” and “®” are not mentioned in each instance in this manual.

Digital Still Camera Mode : Preparation

Number of Recordable Images/Time Length of Moving Image

- ❖ The still images that you recorded are saved in a JPEG file format on the Memory Card.
- ❖ The moving images that you recorded are saved in MPEG4 file format on the Memory Card.
- ❖ Each file has a file number and all files are assigned to a folder.
 - A file number from DCAM0001 is sequentially assigned to each recorded image.
 - Each folder is numbered from 100SSDVC and recorded on the Memory Card.

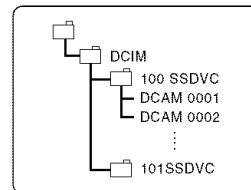

Memory Card Functions

Size	Still Image			
	TIFF	SUPER FINE	FINE	NORMAL
2592x1944	Approx. 1	Approx. 6	Approx. 12	Approx. 18
2272x1704	Approx. 1	Approx. 7	Approx. 15	Approx. 23
2048x1536	Approx. 1	Approx. 9	Approx. 19	Approx. 28
1600x1200	Approx. 2	Approx. 15	Approx. 31	Approx. 47
1024x768	Approx. 6	Approx. 36	Approx. 68	Approx. 95
640x480	Approx. 15	Approx. 95	Approx. 158	Approx. 238

Size	Moving Image	
	30fps	15fps
640x480	Approx. 1min	Approx. 2min
320x240	Approx. 2min	Approx. 3min



[Notes]

- The above approximation is based on a 16MB Memory Stick under normal recording conditions.
- The number of pictures that can be stored on a Memory Card depends on various conditions.

Digital Still Camera Mode : Functions

Numbering Stored Pictures

- ❖ File numbers are given to images in the order they were recorded when they are stored on the Memory Card.
- ❖ You can reset the numbering back to DCAM0001 at any time by setting the FILE to RESET.

1. Set the **Power** switch to  (CAMERA).
2. Press the **MENU** button.
3. Move the **Joystick** to the left or right to select  (SETUP).
 - The SETUP menu list will appear.
4. Move the **Joystick** up or down to select **FILE**, then move the **Joystick** to the right.
 - The RESET and SERIES options are displayed.
 - RESET: When there are no files stored on the Memory card, the file numbering starts from 0001.
 - SERIES: When there are existing files, the image will be named as the number in the sequence.
5. Select your option by moving the **Joystick** up or down, then press the **Joystick(OK)** or **MENU** button.
 - The selected option is applied.

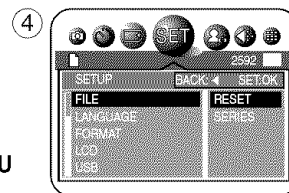
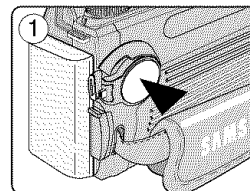







[Notes]

- The file numbers start from DCAM0001 at the time of purchase.
- Moving images are stored in the folder DCIM.
- File numbering for a Memory Card that contains image files from another device, will begin after the largest number.
- A previously formatted Memory Card using a personal computer might require reformatting.
- **DCF ERROR** message is displayed when it exceeds the limit. If this occurs, delete files or format your Memory Card after moving your data stored in the Memory Card to a PC.

Digital Still Camera Mode : Functions

Setting the Image Quality

- ❖ Image Quality function works in  (Program), M, S, A and SCENE modes.
- ❖ Set the level of image quality for the still images before you begin. The number of stored images varies depending on the Memory Card capacity, image size and quality.

1. Set the **Power** switch to  (CAMERA).
2. Set the **Mode Dial** to  (Program), M, S, A or SCENE.
3. Press the **MENU** button.
4. Move the **Joystick** to the left or right to select  (QUALITY).
 - The available options are listed.
TIFF TIFF – SUPER FINE  – FINE  – NORMAL 
5. Select an option by moving the **Joystick** up or down, then press the **Joystick(OK)** or **MENU** button.
 - The icon of the selected mode will be displayed.

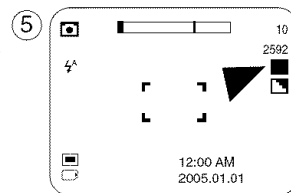
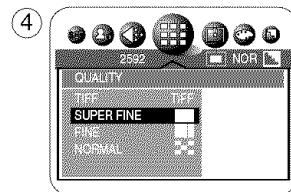
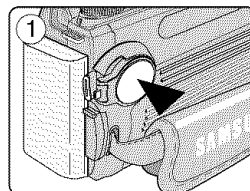







[Notes]

- The actual number of pictures you can record varies depending on the image quality and size settings.
- The TIFF format does not compress the image and therefore produces a larger image size.
- When TIFF is selected, Continuous Shot and AEB modes are not selectable.

Digital Still Camera Mode : Functions

Setting the Image Size

- ❖ Image Size function works in  (Program),  (Movie), M, S, A and SCENE modes.
- ❖ Set the image size for still images before you begin. The number of stored images varies depending on the Memory Card capacity, image size and quality.

1. Set the **Power** switch to  (CAMERA) mode.
2. Set the **Mode Dial** to  (Program),  (Movie), M, S, A or SCENE.
3. Press the **MENU** button.
4. Move the **Joystick** to the left or right to select  (SIZE).
 - The available options are listed.
2592x1944 - 2272x1704 - 2048x1536 - 1600x1200 - 1024x768 - 640x480
5. Select an option by moving the **Joystick** up or down, then press the **Joystick(OK)** or **MENU** button.
 - The selected option is applied.

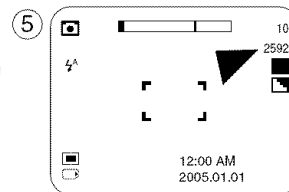
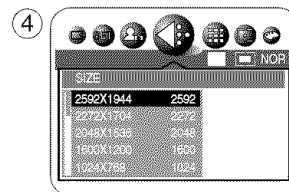
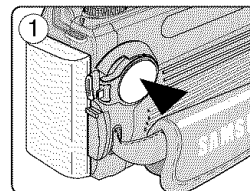



[Notes]

- The actual number of pictures you can record varies depending on the image quality and size settings.
- For photo development, the higher the resolution, the finer the image quality.
- 640x480 format is adequate for e-mail transfers.

Digital Still Camera Mode : Functions

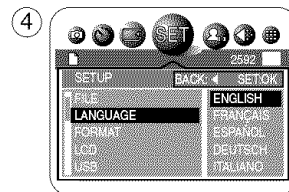
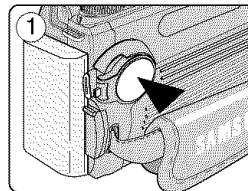

Setting the Menu Language

- ❖ You can choose a language for the OSD (On-screen Display) menu.
 - ❖ Select the appropriate OSD Language from OSD List.
1. Set the **Power** switch to  (CAMERA) mode.
 2. Press the **MENU** button.
 3. Move the **Joystick** to the left or right to select  (SETUP).
 - The SETUP menu list will appear.
 4. Move the **Joystick** up or down to select **LANGUAGE**, then move the **Joystick** to the right.
 - The available options for LANGUAGE setting are displayed.
 5. Select an option by moving the **Joystick** up or down, then press the **Joystick(OK)** or **MENU** button.
 - The OSD language is refreshed in selected language.



Digital Still Camera Mode : Functions

Setting the LCD Brightness

1. Set the **Power** switch to  (CAMERA) mode.
2. Press the **MENU** button.
3. Move the **Joystick** to the left or right to select  (SETUP).
 - The SETUP menu list will appear.
4. Move the **Joystick** up or down to select **LCD**, then move the **Joystick** to the right.
 - The available options are listed.
DARK – NORMAL – BRIGHT
5. Select an option by moving the **Joystick** up or down, then press the **Joystick(OK)** or **MENU** button.
 - The selected option is applied.

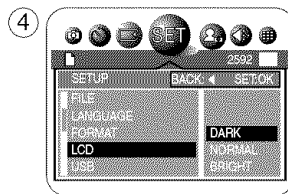
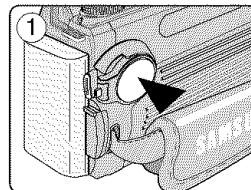



[Notes]

- A brighter LCD screen setting consumes more battery power.
- You may only adjust the brightness of Digital Still Camera mode in  (CAMERA) mode.
- If you want to adjust the brightness of Camcorder mode, see page 34.
- The available menu items are displayed for the selected Camera mode.

Digital Still Camera Mode : Functions

Setting the Clock

- ❖ A built-in clock for Camera mode creates the Time Stamp. For further information on Time Stamp Imprinting, refer to the next page.

1. Set the **Power** switch to  (CAMERA) mode.
2. Press the **MENU** button.
3. Move the **Joystick** to the left or right to select  (SETUP).
 - The SETUP menu list will appear.
4. Move the **Joystick** up or down to select **DATE & TIME**, then move the **Joystick** to the right.
 - The year will be selected first.
5. Move the **Joystick** up or down to set the value. Move to next field by moving the **Joystick** to the right.
6. Repeat Step 5 for the MONTH, DATE and TIME fields.
7. Move the **Joystick** to the right to select the Stamp Format, then move the **Joystick** up or down to select the desired Stamp Format.
 - Available formats: 'YY/MM/DD - MM/DD/'YY - DD/MM/'YY
8. When finished, press the **Joystick(OK)**.
Press the **MENU** button to exit the menu screen.

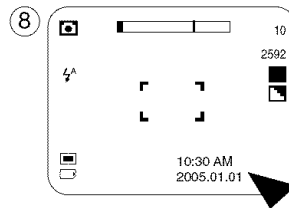
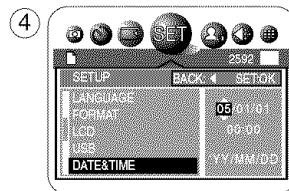
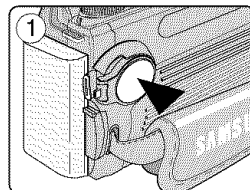

[Notes]



- If you remove the batteries from the camcorder for an extended period of time, or the batteries become run down, you may need to reset the clock.
- You can set the year up to 2037.

Digital Still Camera Mode : Functions

Setting the IMPRINT Option

- ❖ IMPRINT allows the user to place a date stamp on a image. Your camera has a built-in clock that maintains the date and time in a 24-hour format. The camera clock needs to be set if you plan to use the date stamp to imprint the date and time on your image.

Before you begin!

- ❖ Set the Clock (refer to the previous page).
1. Set the **Power** switch to  (CAMERA) mode.
 2. Press the **MENU** button.
 3. Move the **Joystick** to the left or right to select  (SETUP).
 - The SETUP menu list will appear.
 4. Move the **Joystick** up or down to select **IMPRINT**, then move the **Joystick** to the right.
 - The available options are listed.
 - OFF - DATE - DATE&TIME.
 5. Select the desired option by moving the **Joystick** up or down, then press the **Joystick(OK)** or **MENU** button.
 - The selected option is applied.
 - From now on, selected IMPRINT option will be applied to picture takings.

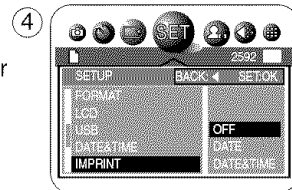
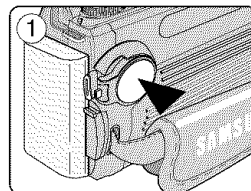



[Notes]

- Every image has its date and time information, regardless of the IMPRINT setting.
- Once the date and time information is stamped on the image, then it is not removable.
- The LCD screen may not display full length of imprint information, you will see full information when you copy to a PC or print the image. It is not malfunctioning.
- If you remove the batteries from the Camcorder for an extended period of time, or the batteries become run out, you may need to reset the clock.
- A separate clock setting for Digital Still Camera mode is required.
For further information on Date & Time setup for the Camcorder, see page 35.

Digital Still Camera Mode : Functions

Setting the Wireless Remote Control Acceptance (WL.REMOTE)

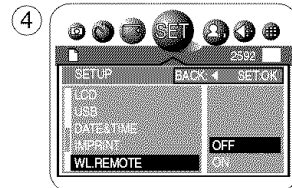
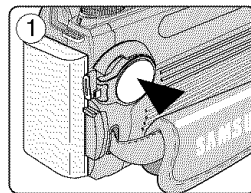

- ❖ Using the Wireless Remote Control, you can easily and remotely manipulate in Camera mode. Refer to page 31 for setting the Wireless Remote Control for Camcorder.
- ❖ Using the Wireless Remote Control provided, you can take a delayed image using the SELF TIMER button (see page 103).

1. Set the **Power** switch to  (CAMERA).
2. Press the **MENU** button.
3. Move the **Joystick** to the left or right to select  (SETUP).
 - The SETUP menu list will appear.
4. Move the **Joystick** up or down to select **WL.REMOTE**, then move the **Joystick** to the right.
 - The available options are listed: OFF and ON.
5. Select an option by moving the **Joystick** up or down, then press the **Joystick(OK)** or **MENU** button.
 - The selected option is applied.





[Notes]

Available Remote Control buttons in each mode:

-  (Movie) for recording: Start/Stop, DISPLAY, W/T (before recording), SELF TIMER
-  (Play) for movie: PLAY, PAUSE, STOP, FF, REW
-  (Program), M, S, A, SCENE, MySET: PHOTO, DISPLAY, W/T, SELF TIMER



Digital Still Camera Mode : Functions

Setting the Beep Sound

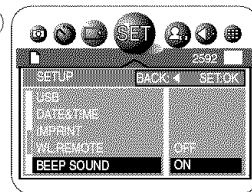
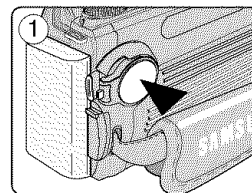
- ❖ You can turn the Beep Sound on or off, when on, each press of a button sounds a beep.
1. Set the **Power** switch to  (CAMERA).
 2. Press the **MENU** button.
 3. Move the **Joystick** to the left or right to select  (SETUP).
 - The SETUP menu list will appear.
 4. Move the **Joystick** up or down to select **BEEP SOUND**, then move the **Joystick** to the right.
 - The available options are listed: OFF and ON.
 5. Select the desired option by moving the **Joystick** up or down, then press the **Joystick(OK)** or **MENU** button.
 - The selected option is applied.







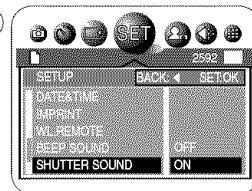
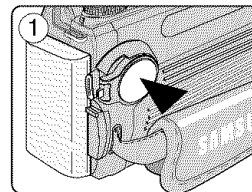



Setting the Shutter Sound

- ❖ You can turn the Shutter Sound on or off. When on, with each press of the PHOTO button the Shutter will sound.
1. Set the **Power** switch to  (CAMERA) mode.
 2. Press the **MENU** button.
 3. Move the **Joystick** to the left or right to select  (SETUP).
 - The SETUP menu list will appear.
 4. Move the **Joystick** up or down to select **SHUTTER SOUND**, then move the **Joystick** to the right.
 - The available options are listed: OFF and ON.
 5. Select the desired option by moving the **Joystick** up or down, then press the **Joystick(OK)** or **MENU** button.
 - The selected option is applied.











Digital Still Camera Mode : Functions







Use of various Functions

Main Menu	Sub Menu	Functions	Available mode	Page
SETUP	FILE	Reset the file numbering	   MySET M S A SCENE	85
	LANGUAGE	Set the OSD language		88
	FORMAT	Format the Memory Card		135
	LCD	Adjust the LCD brightness		89
	USB	USB data destination (PC/PRINTER)		136
	DATE&TIME	Set the Date and Time		90
	IMPRINT	Set the imprint option (Date/Time)		91
	WL.REMOTE	Set the Wireless Remote acceptance		92
	BEEP SOUND	Set the beep sound for key press		93
	SHUTTER SOUND	Set the shutter sound		94
	Q.VIEW	Adjust the Quick Review duration	100	
MYCAM	OFF	Default starting image	   MySET M, S, A SCENE	131
	START IMAGE1	Set a custom starting image		
	START IMAGE2	Set a custom starting image		
	START IMAGE3	Set a custom starting image		
SIZE	2592 X 1944	Change the image size	  M, S, A, SCENE	87
	2272 X 1704			
	2048 X 1536			
	1600 X 1200			
	1024 X 768			
	640 X 480			
	320 X 240	Supports MPEG mode only		
QUALITY	TIFF	Set to TIFF non-compressing format	 M, S, A, SCENE	86
	SUPER FINE	Set to super fine image quality		
	FINE	Set to fine image quality		
	NORMAL	Set to normal image quality		

Digital Still Camera Mode : Functions

Main Menu	Sub Menu	Functions	Available mode	Page
METERING	MULTI	Set the metering to MULTI	 , M, S, A	114
	SPOT	Set the metering to SPOT		
EFFECT	NORMAL	No special effect	 ,  , M, S, A	122
	B & W	Converts colors into Black and White		
	SEPIA	Converts color info. to brown tone		
	NEGATIVE	Reverses colors		
SHARPNESS	SOFT	Changes sharpness setting	 ,  , M, S, A	125
	NORMAL			
	VIVID			
SHOOTING	SINGLE	Normal single image shooting	 , M, S, A (except AEB)	123
	CONTINUOUS	3 continuous image shootings		
	AEB	3 continuous pictures with exposure bracketing		
SELF TIMER	OFF	No delay	 ,  , M, S, A, SCENE	103
	2s SELF	Set to 2 seconds		
	10s SELF	Set to 10 seconds		
SAVE	MYSET1	Stores current setting for quick recall	 , M, S, A	129
	MYSET2			
	MYSET3			
SCENE	NIGHT	Provides a quick access to preset SCENE modes	SCENE	115
	PORTRAIT			
	CHILDREN			
	LANDSCAPE			
	CLOSE-UP			
	SUNSET			
	DAWN			
	BACKLIGHT			
	FIREWORKS			
BEACH&SNOW				

Digital Still Camera Mode : Functions

Main Menu	Sub Menu	Functions	Available mode	Page
FRAME RATE	30fps	Sets the frame rate of MPEG moving images		104
	15fps			
DPOF	STANDARD	Standard DPOF printing function		141
	INDEX	Prints an Index page of all the images stored in the Memory Card.		
	PRINT SIZE	Selects the size of images to print		
	CANCEL	Cancels the current settings for selected menu item		
ROTATE	RIGHT(90°)	Rotates the selected image		127
	LEFT(90°)			
	UPDOWN(180°)			
RESIZE	2272 X 1704	Downsizes the selected image		128
	2048 X 1536			
	1600 X 1200			
	1024 X 768			
	640 X 480			
	START IMAGE	Resize an image to "START IMAGE" to change your starting image.		
SLIDE	INTERVAL	Sets the interval between slides.		99
	REPEAT	Turns the REPEAT option ON or OFF		
	START	Starts the Slide Show.		
PROTECT	ONE PIC	Protects images from accidental erasure		133
	SELECT			
	ALL PICs			
DELETE	SELECT	Deletes Selected images		102
	ALL			





[Note]

Pressing the DISPLAY button while the menu is displayed makes the LCD screen clearer by changing the background into black.

Digital Still Camera Mode : Basic Image Taking



Taking and Viewing Your First Photo

Taking Still Images

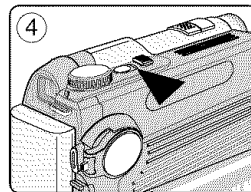
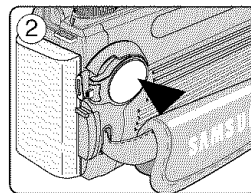
- ❖ This function works in  (Program) mode.
1. Insert the Memory Card (see page 83) and connect a power source (see page 22).
 2. Set the **Power** switch to  (CAMERA) and set the **Mode Dial** to  (Program).
 3. Frame your subject.
 - Frame your subject using the LCD screen or the viewfinder.
 - Use the Zoom Lever to zoom in or zoom out.
 4. Set the focus by pressing the **PHOTO** button halfway down.
 - Locate your main subject inside the focus area indicated by  , then press the PHOTO button halfway down to focus on your main subject.
 - You can move your Camcorder to the desired framing after the focus is locked.
 - Depending on lighting conditions, the built-in flash may work.
 5. Press the **PHOTO** button fully to take the image.
 - The image is taken and saved into the Memory Card within few seconds.
 - Taking another image within this interval is not possible.
 - The Memory Card icon will blink while saving the image.



Taking Still Images: EASY.Q Mode

- ❖ The EASY.Q mode allows a beginner to easily make good recordings. With one press of the EASY.Q button, the Camcorder is automatically set to create the best results under various conditions.
- ❖ You can set EASY.Q mode in all Camera modes except  (Movie) and  (Play) modes. Press the EASY.Q button again to return to the previous mode.

[Note]



The Auto Power Off feature is designed to save the battery power. If there is no operation for more than 5 minutes, the Camcorder will automatically turn off. To resume Camcorder operation, press the Start/Stop button once.

Digital Still Camera Mode : Basic Image Taking



Viewing Still Images

- ❖ You can play back and view still images stored on the Memory Card.
- ❖ Still images stored on the Memory Card are all displayed at the same size despite their original resolution using the LCD screen or viewfinder.
- ❖ There are three ways to view the recorded images in  (Play) mode:
 - Single: To view an image frame by frame
 - Slide Show: To view all images automatically in consecutive order
 - Multiple Display: Up to 9 thumbnails are displayed on the LCD screen at one time.

Viewing a Single Still Image

1. Set the **Power** switch to  (CAMERA).
2. Set the **Mode Dial** to  (Play).
 - The last image taken appears.
3. Move the **Joystick** to the left or right, search for the desired still image.
 - To view the next image, move the **Joystick** to the right.
 - To view the previous image, move the **Joystick** to the left.
 - To view the detailed information on a image, press the **DISPLAY** button.
 - Moving the **Joystick** to the right when you are on the last image will take you to the first image and moving the **Joystick** to the left when you are on the first image will take you to the last image.
 - Keep pressing **Joystick** to the left or right to search quickly for an image.
 - To delete the image displayed, press the **DELETE** () button.



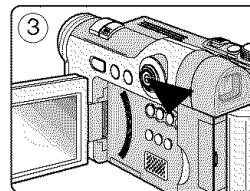
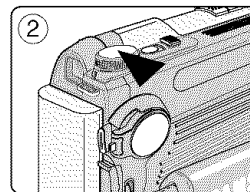
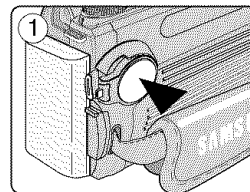

[Notes]

- If there is no stored image in the Memory Card, when you switch to  (Play) mode, a message **NO IMAGE!** is displayed and the MENU button will not function.
- When you connect the Multi-AV cable in the  (Play) mode, the Viewfinder turns off automatically and the TV displays the image.



Digital Still Camera Mode : Basic Image Taking

Viewing a Slide Show

1. Set the **Power** switch to  (CAMERA).
2. Set the **Mode Dial** to  (Play).
 - The last image taken appears.
3. Press the **MENU** button.
4. Move the **Joystick** to the left or right to select  (SLIDE).
 - The SLIDE menu will appear.
5. Move the **Joystick** up or down to select **INTERVAL**, then move the **Joystick** to the right.
6. Select the desired interval by moving the **Joystick** up or down.
 - The available range is 01 ~ 10 seconds.
7. Move the **Joystick** to the left, then move the **Joystick** down to select **REPEAT**.
8. Move the **Joystick** to the right, then move the **Joystick** up or down to select **OFF** or **ON**.
 - The REPEAT option is turned OFF or ON.
9. Move the **Joystick** to the left, then move the **Joystick** down to select **START**.
 - START will be selected.
10. Press the **Joystick(OK)** to start the Slide Show.
 - To pause the Slide Show, press the  (PLAY/STILL) button.
 - To resume the Slide Show, press the  (PLAY/STILL) button again.
11. To stop the Slide Show, press the **Joystick(OK)** or **MENU** button.

[Notes]

- Loading time may vary depending on the image size.
- The Slide Show will start from the current image.
- For moving images, only the first frame is displayed.
- TIFF images are not displayed by the Slide Show.

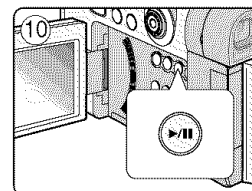
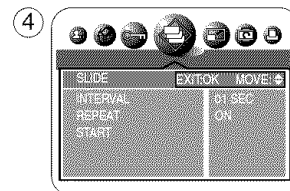
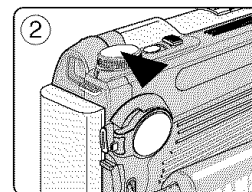
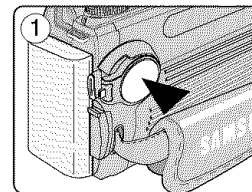

Digital Still Camera Mode : Basic Image Taking

Setting the Q.View Duration

- ❖ The Q.View function works only for still images.
 - ❖ After taking a image, your Camcorder automatically displays the image for a few seconds (Q.View), then returns to recording mode. You can set the Q.View duration using this menu.
1. Set the **Power** switch to **CAMERA**.
 2. Press the **MENU** button
 3. Move the **Joystick** to the left or right to select **SETUP**.
 - The SETUP menu list will appear.
 4. Move the **Joystick** up or down to select **Q.VIEW**, then move the **Joystick** to the right.
 - You can set to 1, 2, 3, 4, 5 seconds or set to OFF.
 5. Select the desired option by moving the **Joystick** up or down, then press the **Joystick(OK)** or **MENU** button.
 - The selected option is applied.

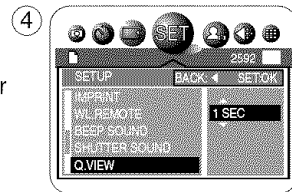
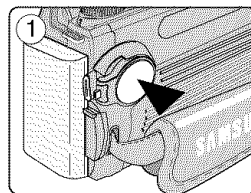

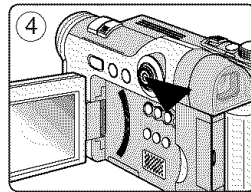
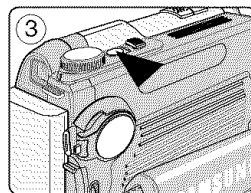

Viewing a Still Image using the Quick Review

- ❖ Quick Review function works in **PROGRAM** (Program), **MOVIE** (Movie), MySET, M, S, A and SCENE modes.
 - ❖ Quick Review is used to view the last recorded still image.
1. Set the **Power** switch to **CAMERA**.
 2. Set the **Mode Dial** to **PROGRAM** (Program), MySET, M, S, A or SCENE.
 3. Record a still image using the **PHOTO** button.
 4. Move the **Joystick** to the left to view the image just taken.
 - To see detailed information on the image, press the **DISPLAY** button once.
 5. To return to Camera mode, move the **Joystick** to the left again or press the **PHOTO** button halfway down.



Digital Still Camera Mode : Basic Image Taking



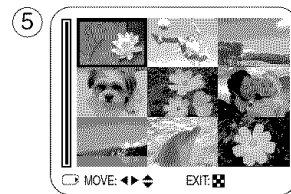
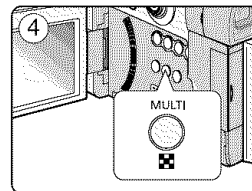

Viewing Multiple Images in Multiple Image View

1. Insert a Memory Card that has previously stored pictures (see page 83).
2. Set the **Power** switch to  (CAMERA).
3. Set the **Mode Dial** to  (Play).
 - A stored image is displayed.
4. Press the **MULTI** () button to display up to 9 pictures.
 - Multiple pictures are displayed and the cursor is on the image you were viewing.
5. Move the **Joystick** to the right, left, up or down to select the desired image.
 - The selected image will be bordered.
6. Press the **Joystick(OK)** to view the selected image in full screen.



Deleting Still Images and Moving Images

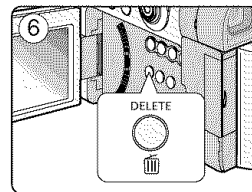

Deleting One Image in Multiple Image View

1. Insert a Memory Card that has previously stored pictures (see page 83).
2. Set the **Power** switch to  (CAMERA).
3. Set the **Mode Dial** to  (Play).
 - A stored image is displayed.
4. Press the **MULTI** () button to display up to 9 pictures.
5. Select a stored image to delete by moving the **Joystick** to the right, left, up or down, then press the **Joystick(OK)**.
6. Press the **DELETE** () button to delete the selected image.
 - The message **DELETE?** and the available options are displayed.
7. Press the **Joystick(OK)** to delete the image or move the **Joystick** to the left to cancel.
 - If deleted, the previous or the last image stored is displayed.
 - If canceled, it returns to the previous screen.



Digital Still Camera Mode : Basic Image Taking

Deleting Image Using DELETE Menu

1. Set the **Power** switch to  (CAMERA).
2. Set the **Mode Dial** to  (Play).
 - A stored image is displayed.
3. Press the **MENU** button.
4. Move the **Joystick** to the left or right to select  (DELETE).
 - The available options are listed: **SELECT** and **ALL**.

❖ Selecting Images to Delete

5. Move the **Joystick** up or down to select **SELECT**, then move the **Joystick** to the right.
6. Move the **Joystick** up or down to select **YES**, then press the **Joystick(OK)**.
7. Move the **Joystick** up, down, left or right to select an image to delete, then press the **MENU** button.
 - To cancel the selection, press the **MENU** button again.
8. When you are done with selection, press the **Joystick(OK)**.
 - A message **PLEASE WAIT** appears and the selected image will be deleted.
 - The last still image or moving image is displayed.

❖ Deleting All Images At Once

5. Move the **Joystick** up or down to select **ALL**, then move the **Joystick** to the right.
6. Move the **Joystick** up or down to select **YES**, then press the **Joystick(OK)**.
 - The message **DELETE ?** appears.
7. Press the **Joystick(OK)** to delete. Or move the **Joystick** to the left to cancel.



[Notes]

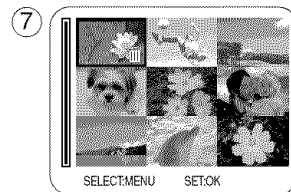
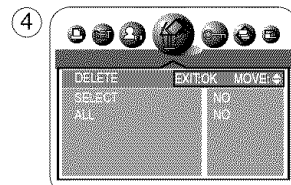
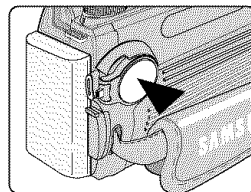





- When there is no stored image on the Memory Card, the message **NO IMAGE!** will be displayed.
- If an erroneous Memory Card format is found on the Memory Card, the message **CARD ERROR!** will be displayed.
- If an erroneous image file is found on the Memory Card, the message **FILE ERROR!** will be displayed. It may be caused by copying images from different digital devices.
- To protect important image from accidental deletion, activate the image protection (see page 133).



Digital Still Camera Mode : Basic Image Taking

Delayed Recording – Self Timer

- ❖ Self Timer function works in  (Program),  (Movie), M, S, A and SCENE modes.
- ❖ Using the remote control, delaying the shutter release (in order to take self-photography and various other camera uses) is available.

1. Set the **Power** switch to  (CAMERA).
2. Set the **Mode Dial** to  (Program),  (Movie), M, S, A or SCENE.
3. Press the **MENU** button.
4. Move the **Joystick** to the left or right to select  (SELF TIMER).
 - The available options are listed.
 - OFF - 2s SELF - 10s SELF
5. Select an option by moving the **Joystick** up or down, then press the **Joystick(OK)** or **MENU** button.
 - The icon of the selected mode will be displayed and automatically exits from the menu screen.
 - You can also set the Self Timer by pressing the **SELF TIMER** button on the Remote Control until the desired option is displayed.
 -  : Delays the shutter release by 2 seconds.
 -  : Delays the shutter release by 10 seconds.
6. Frame your subject.
7. Press the **PHOTO** button on the Remote Control or on the Camcorder to start the timer.
 - For moving images, press the **Start/Stop** button on the Remote Control or on the Camcorder.
 - A beep sound will be played and after the time indicated, recording starts.

[Notes]

- Do not obstruct the remote control sensor by putting obstacles between the remote control and Camcorder.
- The remote control range is 4 ~ 5m (13 ~ 17 ft).
- The effective remote control angle is up to 30 degrees left/right from the center line.
- Using a tripod is recommended for delayed recording.

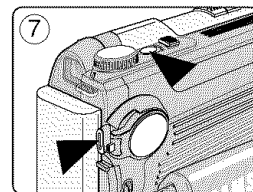
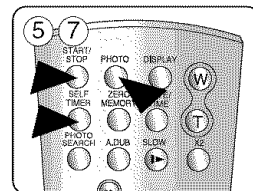
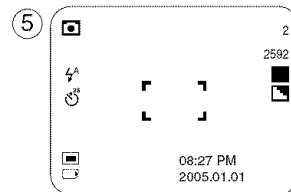
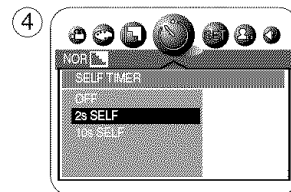



Digital Still Camera Mode : Basic Image Taking

MPEG Recording

- ❖ You can record a moving image using the  (Movie) mode.

Setting the Resolution and Frame Rate

1. Set the **Power** switch to  (CAMERA).
2. Set the **Mode Dial** to  (Movie).
3. Press the **MENU** button.

❖ MPEG Resolution

4. Move the **Joystick** to the left or right to select  (SIZE).
 - The available options are listed.
 - 640x480 - 320x240
5. Select the desired option by moving the **Joystick** up or down, then press the **MENU** button
 - The icon of the selected mode will be displayed and automatically exits from the menu screen.

❖ Setting up the MPEG Frame Rate

4. Move the **Joystick** to the left or right to select  (FRAME RATE).
 - The available options are listed.
 - 30fps - 15fps
5. Select the desired option by moving the **Joystick** up or down, then press the **MENU** button
 - The selected option is applied and automatically exits from the menu screen.

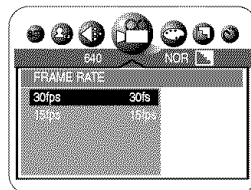
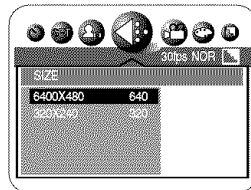
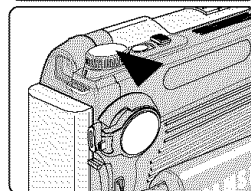
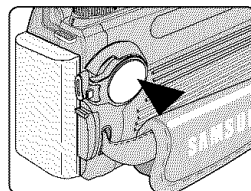

Digital Still Camera Mode : Basic Image Taking

Recording a Moving Image onto a Memory Card

- ❖ You can record a moving image using the **Movie** mode.
 - ❖ Before recording a moving image, insert a Memory Card (see page 83).
1. Set the **Power** switch to **CAMERA**.
 2. Set the **Mode Dial** to **Movie**.
 - Recordable time using the Memory Card is displayed.
 3. Frame your subject, then press the **Start/Stop** button to start recording.
 - The Time Counter starts counting and the recording begins.
 - The Memory Card icon will blink during recording.
 - Zooming is not available during a moving image recording. Zoom in or out before recording.
 4. To pause the recording for a while, press the **Start/Stop** button. To resume recording, press the **Start/Stop** button again.

[Notes]



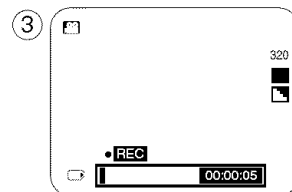
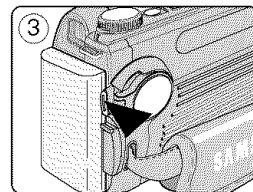
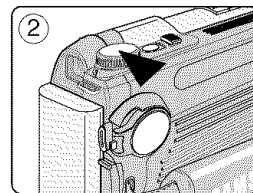
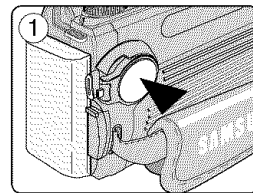





- To use an external microphone, connect a microphone to the MIC jack on the rear of your camcorder.
- When recording moving images, LCD screen may display black bars on its bottom, it is normal. Playing back recorded moving image on the unit and PC shows full screen.
- It is recommended to use a tripod for moving image recordings with the Remote Control. It is also handy for self recordings.
- The recorded moving image is saved in MOV format. To play back a moving image having its extension of ".mov", you will need a Q.Time player that can be installed from the DV Media Pro Software CD provided or from the internet sites. See pages 78 and 81 for further details on software installation.



Digital Still Camera Mode : Basic Image Taking

MPEG Playback

To Playback a Recorded Moving Image

1. Set the **Power** switch to  (CAMERA).
2. Set the **Mode Dial** to  (Play).
 - A stored image is displayed.
3. Move the **Joystick** to the left or right to locate the moving image to be played back.
 - The  (Movie) icon will be displayed when a moving image is selected.
4. Press the  (PLAY/STILL) button to start playback.
 - Playback begins.
5. To pause playback, press the  (PLAY/STILL) button.
To resume playback, press the  (PLAY/STILL) button again.
To stop playback, press the  (STOP) button.
6. During the playback, use the  (FF) button or  (REW) button to move faster to the desired position in the moving image.

[Notes]

- When you play back a moving image on the LCD screen or a connected TV, the sound is not played back. **Recorded sound is played back on a PC after copying or moving the moving image to a PC.**
- In  (Play) mode, the LCD screen may flash when you switch from STOP to PLAY.
- To playback recorded moving images on a PC, install the Quick Time Player from the provided DV Media Pro Software CD.

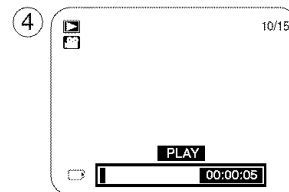
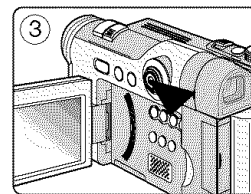
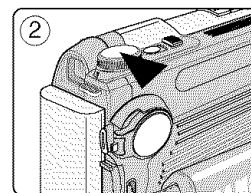
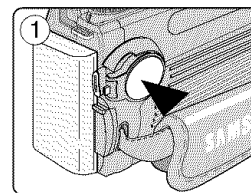

Digital Still Camera Mode : Advanced Techniques





Setting the Focus

- ❖ In  (CAMERA) mode, the automatic focus will not engage unless the PHOTO button is pressed halfway down.
 - ❖ To get good image quality, please verify the proper focus before fully pressing the PHOTO button.
 - ❖ While the camera is focusing (when pressing the PHOTO button halfway down), a flashing red icon (●) will appear on the LCD screen. Once the focus is set properly, a green icon (●) will appear.
 - ❖ A beep sound will be heard once the focus is set.
1. Frame your subject inside the AF focus area on the LCD screen in order to obtain clear focus.
 2. Press the **PHOTO** button halfway down to adjust the focus.
 - When the focus is set, a beep sound will be heard.
 - You can maintain focus by continuing to press the PHOTO button halfway down in order to change your framing. This is useful when your main subject is not located in the center area of your frame.
 3. Press the **PHOTO** button firmly to take the image.

[Notes]

- If the focus is not properly set, release the PHOTO button and then press the PHOTO button halfway down again.
- The flashing red icon (●) will appear when the focus cannot be set. If this occurs, release the PHOTO button and try again.
- Use Macro mode for recording images at closer range, or proper focusing will not occur (see page 112).





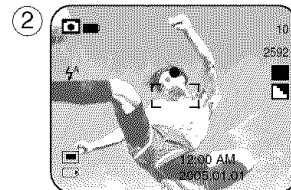
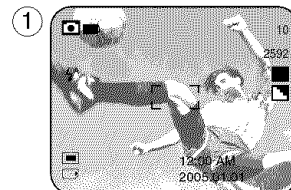

Vibration Warning

- ❖ Vibration Warning () icon and Low Light indicator will appear when you set the flash mode to Slow Sync () or Flash Cancel () in dark lighting conditions, and the PHOTO button is pressed halfway down.
- ❖ Use a tripod or allow the built-in flash to fire to obtain a clear image when the Vibration Warning () icon appears.
- ❖ To change your flash mode, refer to the next page.



Digital Still Camera Mode : Advanced Techniques

Using the Built-In Flash

- ❖ The Flash works in  (CAMERA) modes and allows the user to take brighter pictures in dark locations (i.e. night time shooting, indoors and in shaded areas).
- ❖ Auto Flash, Red-Eye Reduction, Fill-In Flash, Slow Sync and Flash Cancel modes are available.
- ❖ To select a flash mode, move the Joystick up. It will toggle the flash mode between:
 - Auto Flash ()
The flash automatically pops up and fires according to the lighting conditions. Pressing the PHOTO button halfway down will detect the lighting condition. Even if it remains raised, the flash will not fire when there is sufficient light.
 - Red-Eye Reduction ()
The Red-Eye Reduction flash fires before the main flash fires and reduces the Red-Eye effect. Red-Eye Reduction flash mode is effective when the subjects are within range of the flash and looking toward the flash. A slight delay occurs after the PHOTO button is fully pressed, to allow the Red-Eye reduction to take effect. This flash mode is not recommended for fast-moving subjects or long-distance subjects.
 - Fill-In Flash ()
Forces the flash to fire despite the lighting condition. To get better results, it is recommended you use the Fill-In flash mode in backlight conditions, and for shaded subjects under sufficient lighting conditions.
 - Slow Sync ()
The shutter speed is set to slow and the flash fires at the adjusted shutter speed. Use to capture both subject and background at night or in dim light. Use of a tripod is recommended to prevent a blurred image. Slow Sync flash mode allows the user to take brighter backgrounds and subjects at night.
 - Flash Cancel ()
Forces the flash not to fire. Public places such as museums may prohibit flashlight use.

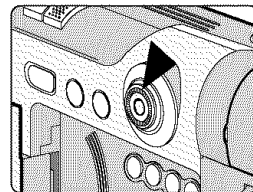

[Notes]

- The flash does not function in CONTINUOUS SHOT, AEB or in the Camcorder mode.
- The battery power will be consumed faster with repeated use of the flash.
- To use the flash again, wait until the flash is fully charged (5 ~ 7 seconds).
- The effective flash range is 7 ~ 10 feet.

Digital Still Camera Mode : Advanced Techniques

Available Flash Modes by Camera Mode

	Program	A Aperture Priority	S S. Speed Priority	M Manual	EASY.Q	Preset SCENE Mode										
	○	X	X	X	X	X	X	X	X	X	X	X	X	X	X	○
	○	X	X	X	○	X	○	○	X	X	X	X	X	X	X	X
	○	○	○	○	X	X	X	X	X	X	X	X	○	X	X	
	○	X	X	X	X	○	X	X	X	X	X	X	X	X	X	X
	○	○	○	○	○	○	X	X	○	○	○	○	X	○	X	

○ = Available

X = Not Available

Digital Still Camera Mode : Advanced Techniques

Setting the Focus Modes

- ❖ Choose a focus mode to suit your subject and composition. Auto focusing, Continuous Auto focusing, Manual focusing, and Macro modes are available.
- ❖ Focus will be automatically set near the center of the frame.



[Note]



Focus is set when you push the PHOTO button halfway down. Focus is set on the subject located nearest the center of the frame. To provide sharper, clearer images, SPOT metering and MULTI metering function are available. See page 114 for further details on Metering Modes.

Auto Focus Mode

- ❖ Use this focus mode in most image taking conditions to obtain the best results.
Set the Power switch to  (CAMERA) mode, automatically sets the focus mode to Auto Focus.

Manual Focus Mode

- ❖ Manual Focus function works in  (Program), M, S, A,  (Movie), MySET and SCENE (NIGHT) modes.
- ❖ Allows the user to adjust the focus manually.
- ❖ When Manual Focus mode is set, [MF] is displayed.

1. Set the **Power** switch to  (CAMERA).
2. Set the **Mode Dial** to  (Program), M, S, A,  (Movie), MySET or SCENE (NIGHT).
 - For SCENE mode, it only works in NIGHT mode.
3. Press the **MF/AF** button until [MF] icon is displayed.
 - [MF] icon will be displayed with a focus bar.
4. To adjust the focus, move the **Quick menu selector** up or down.
 - Selected focus distance is displayed.
5. Press the **PHOTO** button to take the photo.
6. To return to Auto Focus Mode, press the **MF/AF** button until the [MF] icon disappears.

[Note]

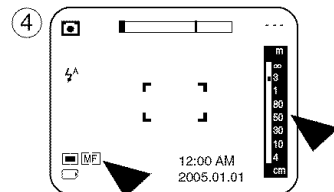
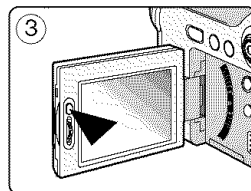

Manual Focus is not available when the distance is less than 30cm (0.9 ft) in TELE mode.



Digital Still Camera Mode : Advanced Techniques

Continuous Auto Focus Mode

- ❖ Continuous Auto Focus function works in  (Program), MySET, M, S, A and SCENE (CHILDREN and CLOSE-UP) modes.
- ❖ The CHILDREN mode enables you to take better pictures when children will not "stay still".
- ❖ Allows the user to focus rapidly, whereas the single auto focus gives a less rapid response but saves battery power.
- ❖ When Continuous Auto Focus mode is selected, [CAF] icon is displayed on the LCD screen.

1. Set the **Power** switch to  (CAMERA).
2. Set the **Mode Dial** to  (Program), MySET, M, S or A.
 - Continuous Auto Focus is set automatically when you set the scene mode to CHILDREN or CLOSE-UP.
3. Press the **MF/AF** button until **[CAF]** icon is displayed.
 - The [CAF] icon is displayed.
4. Press the photo button to take the photo.
5. To return to Auto Focus Mode, press the **MF/AF** button until the **[CAF]** icon disappears.

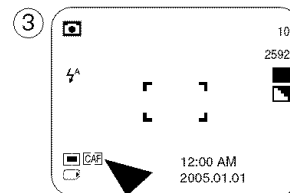
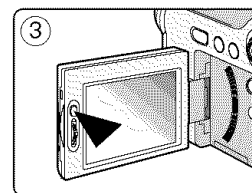







[Notes]

- EASY.Q mode selects the AUTO FOCUS automatically.
- Be sure to confirm that the focus is set using the LCD screen or the viewfinder when Manual Focusing is used.
- Continuous Auto Focus will consume more battery power.

Digital Still Camera Mode : Advanced Techniques

Macro Mode

- ❖ Macro Mode function works in  (Program),  (Movie), MySET, M, S, A and SCENE(CLOSE-UP only) modes.
- ❖ The Macro Focusing mode allows the user to take a close-up image of a detailed subject.
- ❖ Your camera can focus on subjects as close as 4cm (about 1.57 inches).

1. Set the **Power** switch to  (CAMERA).
2. Set the **Mode Dial** to  (Program),  (Movie), MySET, M, S or A.
3. Move the **Joystick** to the right.
 - The Macro mode () icon will be displayed.
4. Frame your subject and close-up by zooming in or out if required.
5. Press the **PHOTO** button to take the close-up picture.
6. To exit Macro mode, move the **Joystick** to the right again.
 - The Macro mode () icon will be disappeared.

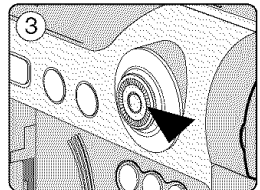
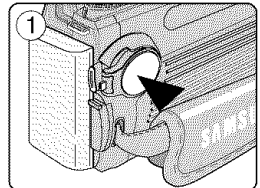

Modes and Focusing Distances Supported

Modes	Normal	Macro (W: Wide, T: TELE)	
Distance	80cm ~ Infinity 31.5 inch ~ Infinity	W: 4 ~ 80cm W: 1.6 ~ 31.5 inch	T: 30 ~ 80cm T: 11.8 ~ 31.5 inch



[Notes]

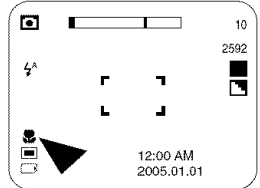

- Be careful not to cast a shadow over your subject when recording in Macro Mode.
- When you cannot get proper focus on the subject, zoom in or out to obtain clear focus.
- The LCD screen displays your framing more precisely.
- Macro is set automatically in CLOSE-UP preset scene mode.





Digital Still Camera Mode : Advanced Techniques

Setting the Exposure

- ❖ Exposure, shutter speed and ISO sensitivity affects image brightness and overall image quality. Longer exposure, slower shutter speed and higher ISO sensitivity brighten the image. Adjustment of these settings is available when you are using  (Program), A, S and M camera modes. You can adjust the overall image brightness by adjusting the Exposure, Shutter Speed and ISO settings.
- ❖ Overall brightness of a captured image may appear too dark if large parts of the framed scene are very bright or the background is much brighter than the main subject. Overall brightness of captured image may appear too bright if large parts of the framed scene are dim or the background is much darker than the main subject. Exposure compensation can be achieved by adjusting the Exposure, Shutter Speed or ISO settings.
- ❖ Set the **Power** switch to  (CAMERA).

Exposure Compensation	 (Program), M, S, and A modes
Shutter Speed Adjustment	S and M modes
Aperture Adjustment	A and M modes
ISO Sensitivity Setting	 (Program), M, S, and A modes

Locking the Auto Exposure: AE LOCK

- ❖ AE LOCK function works in  (Program),  (Movie), MySET and SCENE modes.
 - ❖ You can lock the exposure setting for situations where you want to darken a high contrast subject and background.
1. Frame your subject using the LCD screen, then move the **Joystick** down (AE LOCK).
 2. Re-frame your subject if so desired.
 3. Press the **PHOTO** button halfway down to enable the AE LOCK obtaining clear focus on the subject.
 - You may set the focus on a different subject.
 4. Press the **PHOTO** button firmly to take a photo image.

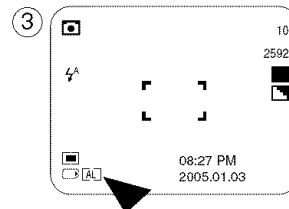
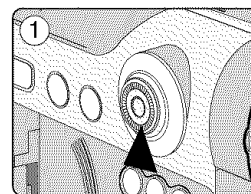





[Note]

After taking a photo image, the AE LOCK is automatically released.

Digital Still Camera Mode : Advanced Techniques

Setting the Auto Exposure Metering Options: SPOT AE or MULTI AE

- ❖ MULTI and SPOT AE functions work in  (Program), M, S and A modes.
- ❖ Use this function to adjust the exposure of the subject to obtain better results.
- ❖ MULTI AE meters the lighting condition of the overall image by metering the exposure on multiple points.
- ❖ SPOT AE meters the lighting condition of a narrower area in order to have precise exposure control over a specific subject.
- ❖ The METERING menu allows you to select between SPOT AE and MULTI AE for automatic exposure metering control.

1. Set the **Power** switch to  (CAMERA).
2. Set the **Mode Dial** to  (Program), M, S or A.
3. Press the **MENU** button.
4. Move the **Joystick** to the left or right to select  (METERING).
 - The available options are listed.
MULTI - SPOT.
5. Select an option by moving the **Joystick** up or down, then press the **Joystick(OK)** or **MENU** button.
 - The selected option is applied and automatically exits from the menu screen.

[Note]

SPOT is set automatically when you set the scene mode to Backlight.

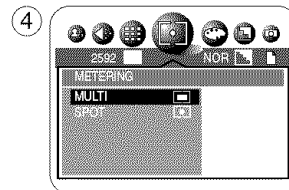
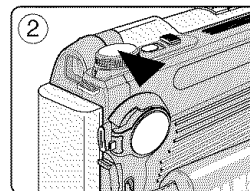
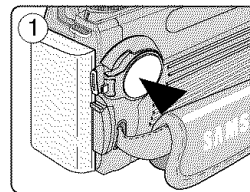

Digital Still Camera Mode : Advanced Techniques

SCENE Modes – Preset Auto Exposure Modes

- ❖ Preset SCENE modes are provided to assist the user in taking pictures under various lighting conditions.
- ❖ The SCENE modes direct the camera to automatically adjust the aperture, shutter speed and white balance according to the lighting conditions and preset settings.

The available SCENE modes are:

NIGHT		PORTRAIT	
CHILDREN		LANDSCAPE	
CLOSE – UP		SUNSET	
DAWN		BACKLIGHT	
FIREWORKS		BEACH&SNOW	

- The CHILDREN mode is available for capture for the active children in action.
1. Set the **Power** switch to (CAMERA).
 2. Set the **Mode Dial** to SCENE.
 3. Press the **MENU** button.
 4. Move the **Joystick** to the left or right to select (SCENE), then move the **Joystick** down.
 - The available options are displayed.
 5. Select an option by moving the **Joystick** up or down, then press the **Joystick(OK)** or **MENU** button.
 - The selected option is applied and automatically exits from the menu screen.

[Note]

In the SCENE(NIGHT) mode, pressing the Quick menu selector displays LT (Long Time) settings menu. You can adjust Shutter Speed and Aperture Value for still images moving the Joystick to the left or right.



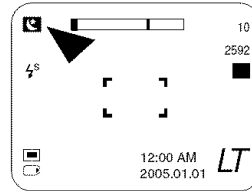
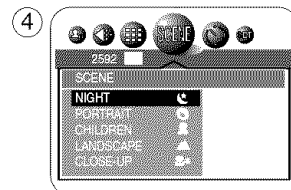
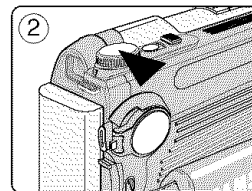
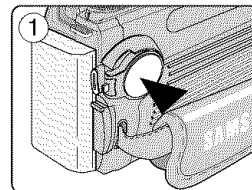

- Shutter Speed Range: AUTO, 1/2,000 ~ 15S
- Aperture Range: AUTO, F2.8 ~ F11.0 (depending on zoom position)



Digital Still Camera Mode : Advanced Techniques

Manual Exposure Compensation

- ❖ The Manual Exposure compensation function works in  (Program), S and A modes.
- ❖ If the image in the LCD screen is too bright, choose a negative value for exposure compensation.
- ❖ If the image in the LCD screen is too dark, choose a positive value for exposure compensation.

1. Set the **Power** switch to  (CAMERA).
2. Set the **Mode Dial** to  (Program), S or A.
3. Press the **Quick menu selector**.
4. Move the **Joystick** up or down to select  icon.
 - The Exposure Control Bar appears.
5. Move the **Joystick** to the left or right button to adjust the Exposure Compensation.
 - Positive compensation brightens the image, while negative compensation darkens the image.
6. When you are satisfied, press the **Quick menu selector** again.
 - The  icon remains on LCD screen while the Exposure Control Bar disappears.

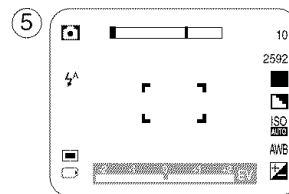
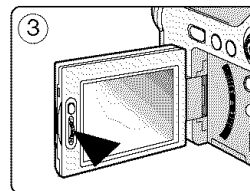
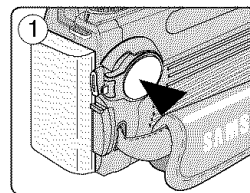

Digital Still Camera Mode : Advanced Techniques

Setting the Aperture

- ❖ Aperture function works in M and A modes.
- ❖ By controlling the aperture, the user may adjust the overall image brightness.
- ❖ Large apertures require more lighting and soften the background details.
- ❖ Smaller apertures will increase the depth of field, bringing the main subject and the background into focus.

1. Set the **Power** switch to  (CAMERA).
2. Set the **Mode Dial** to M or A.
3. Press the **Quick menu selector**.
4. Move the **Joystick** up or down to select Aperture Setting (f-number).
 - The current Aperture Setting (f-number) will be selected in Green.
5. Move the **Joystick** to the left or right to set the desired aperture value.
 - The available Aperture Range: F2.8 ~ F11.0
6. When you are satisfied, press the **Quick menu selector**.
 - The selected aperture setting is displayed on the LCD screen and exits the setup screen.

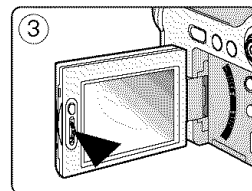
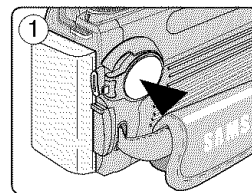

[Notes]

- A (Aperture) and M (Manual) modes allow the user to make aperture adjustments.
- Maximum and minimum values of the aperture range depend on the zoom position.
- The possible setting range for the aperture varies with zooming.

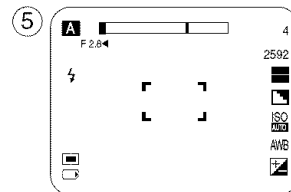

Digital Still Camera Mode : Advanced Techniques

Setting the Shutter Speed

- ❖ The Shutter Speed function works in M and S modes.
- ❖ By controlling the shutter speed and aperture, you may adjust the overall brightness of the image.
- ❖ Slower shutter speeds require more lighting. Faster shutter speeds require less lighting.
- ❖ For fast moving subjects, a slow shutter setting will produce a motion blurring effect.

1. Set the **Power** switch to  (CAMERA).
2. Set the **Mode Dial** to M or S.
3. Press the **Quick menu selector**.
4. Move the **Joystick** up or down to select Shutter Speed Setting.
 - The current Shutter Speed value will be selected in Green.
5. Move the **Joystick** to the left or right to set the desired shutter speed.
 - Available Shutter Speed Range: 1/2000 ~ 15.0 seconds
6. When you are satisfied, press the **Quick menu selector**.
 - The selected aperture setting is displayed.

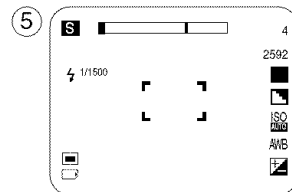
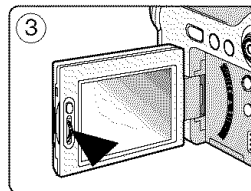
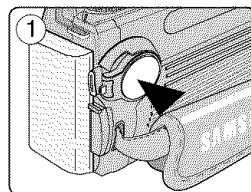



[Note]



Using a tripod for slow shutter settings is recommended.







Digital Still Camera Mode : Advanced Techniques

Setting the White Balance

Setting the Preset White Balance

- ❖ The White Balance function works in  (Program),  (Movie), M, S and A modes.
- ❖ Digital Cameras capture an image using a CCD (Charge Coupled Device) that takes in lighting information and detects the color.
- ❖ The color balance may vary depending on the lighting conditions; white balance is used to preserve natural colors under different lighting conditions.

1. Set the **Power** switch to  (CAMERA) mode.
2. Set the **Mode Dial** to  (Program),  (Movie), M, S or A
3. Press the **Quick menu selector**.
 - The AWB icon will be displayed.
4. Move the **Joystick** up or down to select White Balance (AWB).
 - The White Balance control bar appears while the current setting will be selected in Blue.

						AWB
Manual	Glow Lamp	Halogen	Fluorescent	Cloudy	Sunny	AUTO

5. Move the **Joystick** to the left or right to select the desired White Balance setting.
 - The selected option is highlighted in Blue.
6. Press the **Quick menu selector** again to apply your selection and exit the setting screen.
 - The selected icon will be displayed.



[Notes]

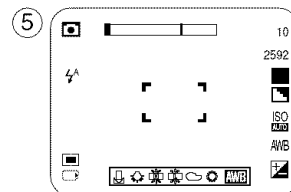
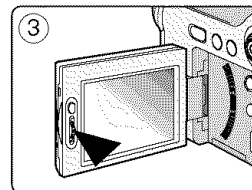
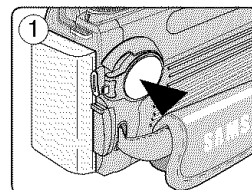



- Setting the White Balance may produce different color balances.
- AWB (Auto White Balance) mode helps to have natural colors under most cases.
- White Balance setting is memorized in current  (CAMERA) mode.
- Using EASY.Q mode cancels the White Balance setting.
To recover your White Balance setting, exit the EASY.Q mode.



Digital Still Camera Mode : Advanced Techniques

Setting the Manual White Balance

❖ The white balance function works in  (Program),  (Movie), M, S and A modes.

1. Set the **Power** switch to  (CAMERA).
2. Set the **Mode Dial** to  (Program),  (Movie), M, S or A.
3. Press the **Quick menu selector**.
 - The AWB icon will be displayed.
4. Move the **Joystick** up or down to select **AWB** (White Balance).
 - The White Balance control bar appears while the current setting will be selected in Blue.
5. Move the **Joystick** to the left or right to select  (Manual).
 - The selected option will be selected in blue.
6. Frame your Camcorder on a white area (such as a wall), filling the LCD screen (or viewfinder) with white.
7. Press the **Joystick(OK)** to set the White Balance.
8. The new White Balance setting will be applied to future picture taking.

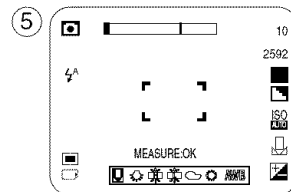
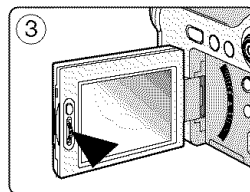
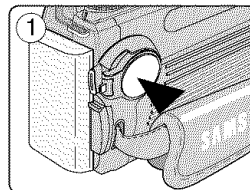



[Notes]

- Using a Bright Gray color area instead of White help brighten the white balance.
- Using colored areas instead of White will emphasize the complementary color.
- White Balance setting is memorized in current  (CAMERA) mode.
- Using EASY.Q mode cancels the White Balance setting.
To recover your White Balance setting, exit the EASY.Q mode.

Digital Still Camera Mode : Advanced Techniques

Setting the ISO Sensitivity

- ❖ The ISO Sensitivity function works in  (Program), M, S and A modes.
- ❖ Sensitivity is a measure of how rapidly the camera reacts to a light source.
The higher the sensitivity, the brighter the image is under the same exposure condition.
- ❖ Allowing the flash to fire will help brighten the image. However, if other settings disable the flash use, set the ISO sensitivity to a higher level.

1. Set the **Power** switch to  (CAMERA).
2. Set the **Mode Dial** to  (Program), M, S or A.
3. Press the **Quick menu selector**.
 - The ISO icon will be displayed.
4. Move the **Joystick** up or down to select ISO Setting.
 - The adjustable ISO control bar appears.
5. Move the **Joystick** to the left or right to set the desired ISO mode.

The available options are:

AUTO	Automatically sets the ISO to compensate for various lighting conditions (up to 400)
50	This mode is recommended for bright lighting conditions.
100	This mode is recommended for most situations except when lighting is poor or when higher shutter speeds are required.
200	The image may be grainy when set to this mode or higher.
400	The image may be grainy. Sharpening may raise the noise level.

6. When you are satisfied, press the **Quick menu selector**.
 - The selected ISO Sensitivity level will be displayed.



[Notes]

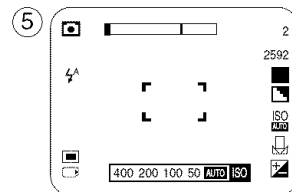
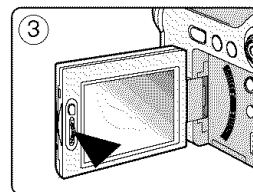
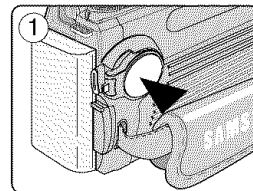



- Higher ISO sensitivity might produce a grainy (noisy) effect on the image.
- AUTO ISO mode will allow you to take quality pictures in most lighting conditions.



Digital Still Camera Mode : Advanced Techniques

Using Digital Special Effects

- ❖ The DSE (Digital Special Effects) function works in  (Program),  (Movie), M, S and A modes.
- ❖ Digital Special Effects allow the user to create professional looking effects on their images.

1. Set the **Power** switch to  (CAMERA).
2. Set the **Mode Dial** to  (Program),  (Movie), M, S or A.
3. Press the **MENU** button.
4. Move the **Joystick** to the left or right to select  (EFFECT).
 - The available options are listed.

NORMAL	No Special Effect is applied
B&W	Changes the image to Black and White
SEPIA	Changes the image to Brown Tones similar to old photos
NEGATIVE	Inverts the Color

5. Select the desired option by moving the **Joystick** up or down, then press the **Joystick(OK)** or **MENU**
 - The selected option is applied.

[Note]

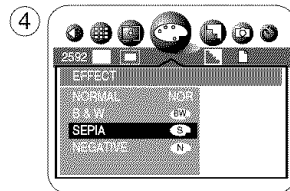
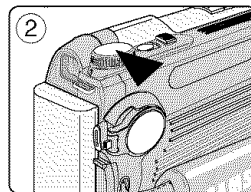
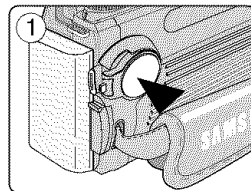

It takes a few seconds to apply the special effects.



Digital Still Camera Mode : Advanced Techniques

Taking Multiple Images Using Auto Exposure Bracketing

- ❖ Auto Exposure Bracketing works only in  (Program) mode.
- ❖ From time to time, determining the best exposure setting for a image may be difficult and you may not have time to check the results and try again. Auto Exposure Bracketing allows the user to vary exposure compensation settings automatically over a series of photos, bracketing a selected exposure compensation setting.
- ❖ Auto Exposure Bracketing takes 3 continuous shots with the following exposure compensations: -5EV (negative), 0EV (standard), +5EV (positive)

1. Set the **Power** switch to  (CAMERA).
2. Set the **Mode Dial** to  (Program).
3. Press the **MENU** button.
4. Move the **Joystick** to the left or right to select  (SHOOTING).
 - The available options are listed.
5. Select an **AEB** by moving the **Joystick** up or down, then press the **Joystick(OK)** or **MENU** button.
 - The selected option is applied.
6. Frame your subject and press the **PHOTO** button to start bracketing.
 - 3 continuous images using exposure bracketing are taken.

[Notes]

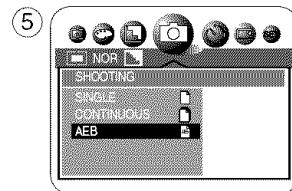
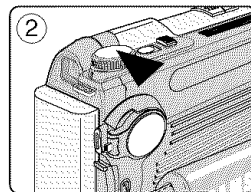
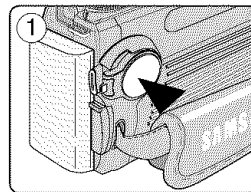

- The Built-In Flash is disabled for Auto Exposure Bracketing and Continuous Shots.
- The Digital Zoom is not available for Auto Exposure Bracketing and Continuous Shots.
- If there is not enough free space to save the 3 images, the Auto Exposure Bracketing will not work.



Digital Still Camera Mode : Advanced Techniques

Taking Multiple Images using Continuous Shot

- ❖ Continuous Shot function works in  (Program), M, S and A modes.
- ❖ Continuous Shot allows the user to take consecutive images of a moving object.
- ❖ Continuous recording will occur while the PHOTO button is being pressed.
 - Records images continuously up to the storage capacity.

1. Set the **Power** switch to  (CAMERA).
2. Set the **Mode Dial** to  (Program), M, S or A.
3. Press the **MENU** button.
4. Move the **Joystick** to the left or right to select  (SHOOTING).
 - The available options are listed.
5. Select an CONTINUOUS by moving the **Joystick** up or down, then press the **Joystick(OK)** or **MENU** button.
 - The selected option is applied.
6. Frame your subject and press the **PHOTO** button to start bracketing.

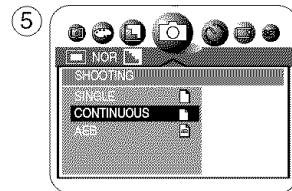
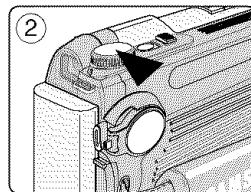
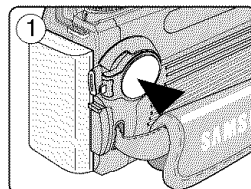







[Notes]

- The Built-In Flash is disabled for Auto Exposure Bracketing and Continuous Shot.
- The Digital Zoom is not available for Auto Exposure Bracketing and Continuous Shot.
- If there is not enough free space to save 3 images, Continuous Shot will not work.

Digital Still Camera Mode : Advanced Techniques

Setting the Sharpness

- ❖ The Sharpness function works in  (Program),  (Movie), M, S and A modes.
- ❖ This option allows the user to obtain sharper images by processing the image after it is shot.

1. Set the **Power** switch to  (CAMERA).
2. Set the **Mode Dial** to  (Program),  (Movie), M, S or A.
3. Press the **MENU** button.
4. Move the **Joystick** to the left or right to select  (SHARPNESS).

- The available options are listed.

SOFT	Smooths the edges
NORMAL	No Sharpening is applied
VIVID	Enhances to sharpen the edges

5. Select the desired option by moving the **Joystick** up or down, then press the **Joystick(OK)** or **MENU** button.
 - The icon of the selected mode will be displayed.

[Note]

Enhancing Sharpness while using the high ISO Sensitivity setting may result in grainy images.

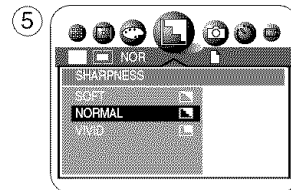
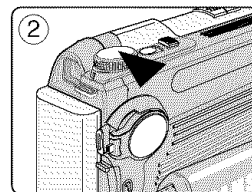
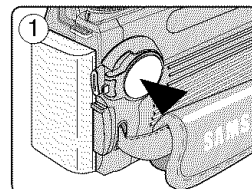

Digital Still Camera Mode : Advanced Techniques

Using the Digital Zoom

- ❖ A 3x optical zoom and 12x digital zoom are available. The Zoom indicator shows the current zooming status. A divider indicates the border between optical and digital zooming.
The digital zoom digitally processes data from the CCD (Charge Coupled Device, Image Sensor) to enlarge the center portion of the image to fill the frame and may produce a less detailed and slightly grainy image.

Zooming In

Push the Zoom Lever toward the TELE side, to zoom in until the zooming indicator crosses the line to the TELE side. After reaching the maximum optical zoom level, pushing the Zoom Lever downward even further automatically turns on the Digital Zoom.

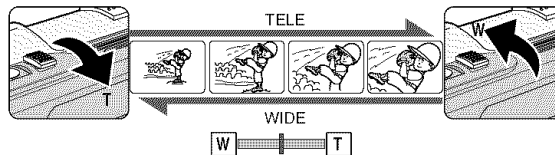

Zooming Out





Push the Zoom Lever toward the WIDE side, to zoom out until the zooming indicator crosses the line to the WIDE side. After reaching the minimum digital zoom level, pushing the Zoom Lever even further automatically turns off the Digital Zoom and returns to the Optical Zoom.

[Notes]

- Digital Zooming may produce grainy (noisy) images.
- Saving images which use the Digital Zoom may take more time.
- The Digital Zoom is not available for moving images, Night scene or Close-up mode.
- Do not obstruct the lens movement while zooming.

Digital Still Camera Mode : Advanced Techniques

Rotating a Stored Image

- ❖ The Image Rotating function works only in the  (Play) mode.
 - ❖ This function works only for still images recorded onto the memory card.
 - ❖ You can rotate a stored image while viewing it.
1. Set the **Power** switch to  (CAMERA).
 2. Set the **Mode Dial** to  (Play).
 - A stored image is displayed.
 3. Move the **Joystick** to the left or right to locate the image you wish to rotate.
 4. Press the **MENU** button.
 5. Move the **Joystick** to the left or right to select  (ROTATE).
 - The available options are listed.
 - RIGHT(90°) - LEFT(90°) - UPDOWN(180°).
 6. Select the desired option by moving the **Joystick** up or down, then press the **Joystick(OK)**.
 - The selected option is applied.

[Notes]

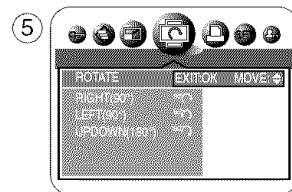
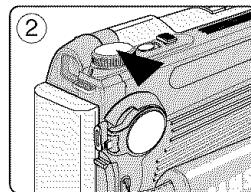
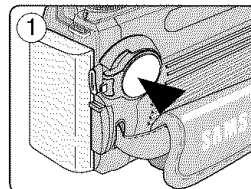

- RIGHT(90°) rotates the image in a clockwise direction.
- LEFT(90°) rotates the image in a counterclockwise direction.
- Rotated image display will have blank margins on the sides.
- Rotating the image for display does not affect the stored image quality. Actual images are not rotated to protect the image quality.



Digital Still Camera Mode : Advanced Techniques

Resizing a Stored Image

- ❖ The Image Resizing function works only in the  (Play) mode.
- ❖ This function works only for still images recorded onto the memory card.
- ❖ Only downsizing is available. Enlarging low resolution images into higher resolutions is not available.
- ❖ Choose this option to scale down your stored images.
- ❖ This function utilizes JPEG technology.

1. Set the **Power** switch to  (CAMERA).
2. Set the **Mode Dial** to  (Play).
 - A stored image is displayed.
3. Move the **Joystick** to the left or right to locate the image you wish to resize.
4. Press the **MENU** button.
5. Move the **Joystick** to the left or right to select  (RESIZE).
 - Available image resolutions are listed.
6. Select the desired option by moving the **Joystick** up or down, then press the **Joystick(OK)**.
 - The selected option is applied.
 - Select START IMAGE if you want to save the image as START IMAGE 3.
(The first two images are Samsung images and cannot be saved.)

[Notes]

- You can select and resize a still image and then save it to appear as your new start-up image (see page 131).
- Resizing for the START IMAGE size saves a new image to the camcorder's internal memory, not to the memory card.
- Only JPEG file types can be resized. TIFF and moving images cannot be resized.
- Only downsizing is supported. Enlarging a image is not supported.
- Resizing does not delete the original image. An additional resized image is saved on the memory card.
- If there is no space for the additional resized image, it is not saved and the message **CARD FULL!** appears.

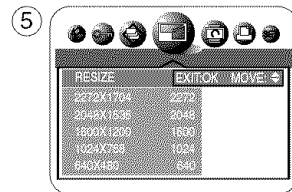
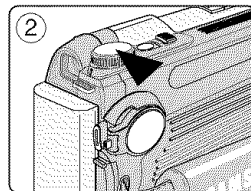
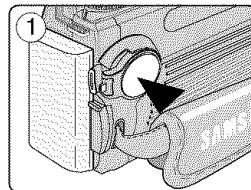



Digital Still Camera Mode : Advanced Techniques

Customizing Your Camera – MySET Menu

- ❖ MySET menu works only in  (Program), M, S and A modes.
- ❖ Customize your camera to memorize frequently accessed settings for easier use.
MySET allows the user to recall memorized settings to ready the camera in seconds.

Memorizing Your Current Settings

- ❖ You can save up to 3 different settings using MYSET1, MYSET2 and MYSET3.
 1. Set the **Power** switch to  (CAMERA).
 2. Set the **Mode Dial** to  (Program), M, S or A.
 3. Set all the options to be memorized such as exposure, white balance, image resolution and other image taking conditions.
 4. Press the **MENU** button.
 5. Move the **Joystick** to the left or right to select  (SAVE).
 - The available options are listed.
 6. Select the desired option by moving the **Joystick** up or down, then press the **Joystick(OK)**.
 - The selected option is applied: MYSET1, MYSET2 or MYSET3.
 - The current settings are saved in the selected MYSET memory.

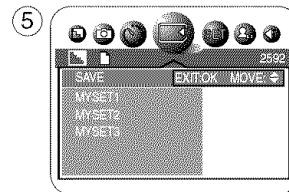
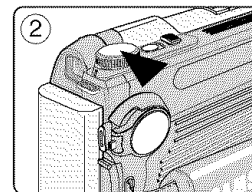
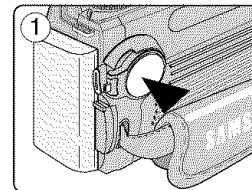

[Notes]

- The settings which can be saved are:
Macro, Self-Timer, Flash, Focus (Manual), Exposure Compensation, White Balance, ISO Sensitivity settings, Image Size, Image Quality, Metering, Digital Special Effect, Sharpness, Continuous Shot, Scene, Setup Menu and other settings.
- The Flash mode and Continuous Shot settings cannot be saved at the same time.
- The saved F. No may change when you adjust the zoom lever to zoom in or out.



Digital Still Camera Mode : Advanced Techniques

Loading Your Customized Settings

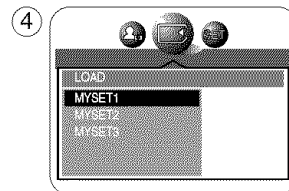
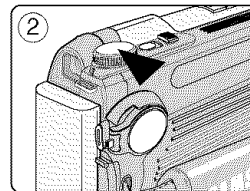
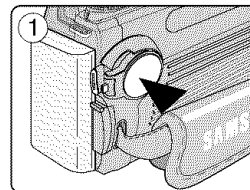

- ❖ After saving your MySET configurations as instructed in the previous page, follow these steps to recall your MySET configuration at a later time.
1. Set the **Power** switch to  (CAMERA).
 2. Set the **Mode Dial** to MySET.
 3. Press the **MENU** button.
 4. Move the **Joystick** to the left or right to select  (LOAD).
 - The available options are listed.
MYSET1 - MYSET2 - MYSET3
 5. Select the desired option by moving the **Joystick** up or down, then press the **Joystick(OK)** or **MENU** button.
 - The selected option is applied.



Digital Still Camera Mode : Advanced Techniques

Customizing Your Camera – Changing the Start-Up Image

- ❖ This function changes the starting image that is displayed when the camera is turned on.
- ❖ You can select and resize a still image to appear as your new start-up image.

1. Set the **Power** switch to  (CAMERA).
2. Press the **MENU** button.
3. Move the **Joystick** to the left or right to select  (MYCAM).
4. Move the **Joystick** up or down to select **START IMAGE 3**, then press the **Joystick(OK)**.
 - The selected option is applied.
 - You must first select an image to save in START IMAGE 3. (See page 128)

[Notes]

- START IMAGE 1 and START IMAGE 2 are Samsung logo images and cannot be changed.
- Formatting or deleting the still image on the memory card does not affect the start-up images. Start-up images are saved in the built-in internal memory of the Camcorder.

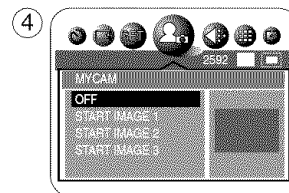
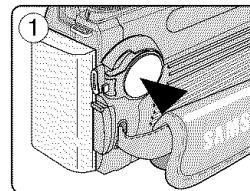



Digital Still Camera Mode : Advanced Techniques

Zooming & Trimming Recorded Images (Playback ZOOM) While Viewing

- ❖ This function allows the user to have a more detailed view of the image using the LCD screen.
- ❖ Enlarge a portion of the image to see more detail and move the zoom tool around the image.

Zooming the Image

1. Set the **Power** switch to  (CAMERA).
2. Set the **Mode Dial** to  (Play).
 - A stored image is displayed.
3. Select a image by moving the **Joystick** to the left or right.
 - The selected image is displayed.
4. Pull the Zoom Lever to TELE side to enter the zoom mode, then use the Zoom Lever to zoom in or zoom out.
 - A small window appears in the bottom left of the LCD screen showing the current portion of the full image.
5. Move the **Joystick** up, down, left or right to move around the image.
6. To exit Playback Zoom, push the zoom lever toward the W(WIDE) end until the image returns to normal size.
 - The small window disappears and returns to normal viewing mode.

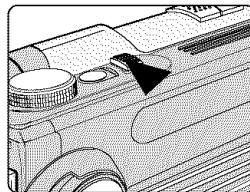
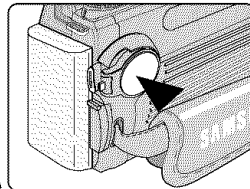

Trimming the Image

1. Pull the Zoom Lever to TELE side to enter the zoom mode, then use the Zoom Lever to zoom in or zoom out.
 - Move **Joystick** up, down, left or right to move around the image.
2. Zoom in to any portion of a stored image following the instructions above.
3. Press the **Joystick(OK)**.
 - The message **TRIMMING?** will be displayed.
4. Press the **Joystick(OK)** to confirm the trim, or move the **Joystick** to the left to cancel.
 - OK: Precedes with the trimming and saves the trimmed image as a new file.
 - LEFT: Cancels the trimming and returns to PLAY mode.

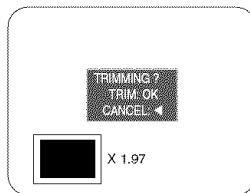





[Note]

Trimming an image produces a new trimmed image which is saved on the memory card. If no space is available to store the new trimmed image, it automatically cancels.



Digital Still Camera Mode : Advanced Techniques

Protecting Stored Images

- ❖ The Protection function works only in  (Play) mode.
- ❖ Selecting Protect from the MENU saves valuable images from accidental deletion.
- ❖ You may set a image to LOCK to protect it, or UNLOCK to cancel the protection.

1. Set the **Power** switch to  (CAMERA).
2. Set the **Mode Dial** to  (Play).
 - A stored image is displayed.
3. Press the **MENU** button.
4. Move the **Joystick** to the left or right to select  (PROTECT).
 - The available options are listed.
ONE PIC - SELECT - ALL PICs.
5. Select the desired option by moving the **Joystick** up or down, then press the **Joystick(OK)**.
 - The selected option is applied.

To Protect Current Image

- ❖ Select **ONE PIC**.
1. Move the **Joystick** up or down to select **ONE PIC**, then press the **Joystick(OK)**.
 - The available options are displayed: LOCK or UNLOCK.
 2. Move the **Joystick** up or down to **LOCK** or **UNLOCK** the image, then press the **Joystick(OK)** to set your choice.
 - The protection () icon will be displayed for locked (protected) images or protection () icon disappears when it is unlocked.

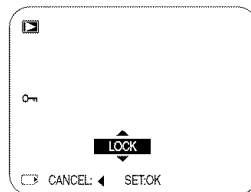
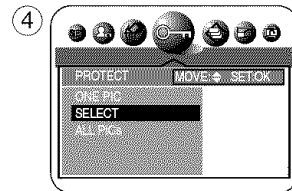
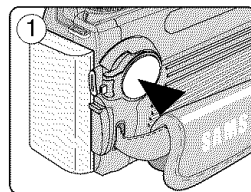

Digital Still Camera Mode : Advanced Techniques

To Select Images to be Protected

❖ Select **SELECT**.

1. Move the **Joystick** up or down to select **SELECT**, then press the **Joystick(OK)**.
 - The multiple images screen appears.
2. To move the cursor, move the **Joystick** up, down, left or right, then press the **MENU** button to lock the selected image.
 - The protection (🔒) icon will be displayed on the image.
3. To cancel the protection and unlock the image, press the **MENU** button again on a selected image.
 - The protection (🔒) icon disappears.
4. When you are done, press the **Joystick(OK)** to exit the multiple images screen.
 - It will return to the one image screen.

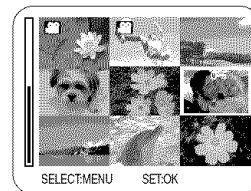

To Protect All Images

1. Move the **Joystick** up or down to select **ALL PICs**, then press the **Joystick(OK)**.
 - The available LOCK and UNLOCK options are displayed.
2. Select the desired option by moving the **Joystick** up or down, then press the **Joystick(OK)**.
 - Your selection is applied. When all images are locked, the protection (🔒) icon will be displayed on each image.

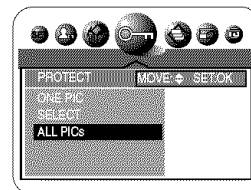

[Notes]

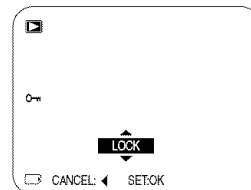

- Protected images will show the protection (🔒) icon when they are displayed.
- If the write protection tab on the memory card is set to LOCK, you cannot set image protection.



Using the Camera - Advanced Techniques

Formatting a Memory Card

- ❖ You can use the Format function to completely delete all still images/moving images and options on the Memory Card, including protected still images/moving images.
- ❖ The format function restores the Memory Card to its initial state.
- ❖ The Memory Stick supplied with this Camcorder has been formatted already.

1. Set the Power switch to  (CAMERA).
2. Press the **MENU** button.
3. Move the **Joystick** to the left or right to select  (SETUP).
 - The SETUP menu list will appear.
4. Move the **Joystick** up or down to select **FORMAT**, then move the **Joystick** to the right.
 - The available options are listed.
YES - NO.
5. Select the desired option by moving the **Joystick** up or down button, then press the **Joystick(OK)**.
 - If YES is selected, message **FORMAT?** appears.
6. If **OK** is selected, message **PLEASE WAIT** appears and then **FORMAT DONE** appears when the format is completed.

[Notes]

- If you execute the Format function, all still images/moving images will be erased completely and erased still images/moving images cannot be recovered.
- Formatting the Memory Card using a different device will cause Memory Card read errors.
- Formatting the Memory Card deletes all the stored data in the Memory Card.
- Do not turn the power off while formatting.

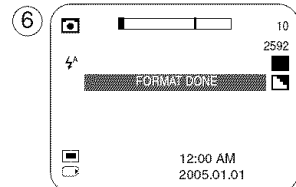
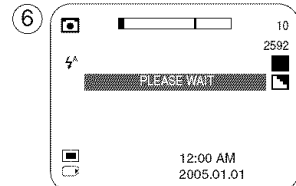
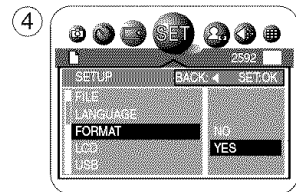



Digital Still Camera Mode : Advanced Techniques

Printing Your Images – Using the PictBridge™

- ❖ By connecting the Camcorder to printers with PictBridge support (sold separately), you can send images from the memory card directly to the printer with a few simple operations using the Camcorder buttons.
- ❖ With the PictBridge Support, you can control the printer directly through your Camcorder in order to print out stored images. For direct printing of your stored images using the PictBridge function, you must connect your Camcorder to a PictBridge printer using a USB cable.
- ❖ To print out images stored in the memory card using PictBridge support, follow the steps:
 - Connect your camcorder to a PictBridge supporting printer and then select images to print.
 - Customize print options as described in page 138 if desired and then print your selected images (see page 139).

Connecting To a Printer

1. Set the **Power** switch to  (CAMERA).
2. Set the **Mode Dial** to  (Play), then press the **MENU** button.
3. Move the **Joystick** to the left or right to select  (SETUP), then move the **Joystick** down.
 - The SETUP menu list will appear.
4. Move the **Joystick** up or down to select **USB**, then move the **Joystick** to the right.
 - The available options are listed: COMPUTER and PRINTER.
5. Select **PRINTER**, then press the **Joystick(OK)** or **MENU** button.
7. Connect your camcorder to the printer using the provided USB cable.
8. Turn your printer power on.
 - The PictBridge connection screen appears. The messages **PLEASE WAIT** and **USB I/F PRINTER** (or **USB I/F COMPUTER**) appear for a short time, then the PictBridge menu screen appears.

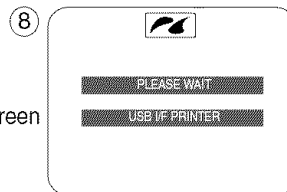
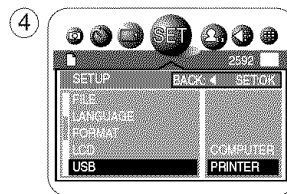

[Notes]

- If the USB option is set to COMPUTER, USB I/F COMPUTER will be displayed on the LCD or Viewfinder with a **PLEASE WAIT** message.
- If the USB option is set to PRINTER, USB I/F PRINTER will be displayed with a PLEASE WAIT message on the LCD or Viewfinder.
- The PictBridge™ is a registered trademark of CIPA(Camera & Imaging Products Association), an image transfer standard developed by Canon, Fuji, HP, Olympus, Seiko Epson, and Sony.

Digital Still Camera Mode : Advanced Techniques

Selecting Images

- ❖ To select images, select SELECT.
1. In the PictBridge settings menu, move the **Joystick** up or down to select **SELECT**.
 2. Move the **Joystick** to the right.
 - The available options are listed: ONE PIC and ALL PICs.
 3. Select the desired option moving the **Joystick** up or down, then press the **Joystick(OK)**.
 - If ONE PIC is selected, number of prints setting menu is displayed on top of the current image. To change the number of prints, move the **Joystick** up or down. To find another image, move the **Joystick** to the left or right.
 - If ALL PICs is selected, number of prints setting menu is displayed on the multiple image screen. To change the number of prints, move the **Joystick** up or down.
 4. Press the **Joystick(OK)** to confirm the number of prints and press the **MENU** button.
 - It will return to the PictBridge settings screen.

[Notes]

- The actual setup menu screen may differ from above instructions depending on the PictBridge printer's manufacturer. Refer to the printer's documentation for further details.
- Unsupported menu items are displayed on the LCD screen as deactivated.

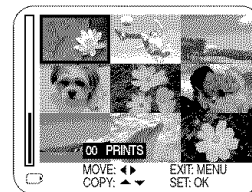
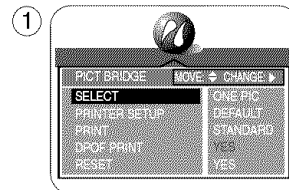

Digital Still Camera Mode : Advanced Techniques

Customizing Print Options

- ❖ To customize your print options such as PAPER SIZE, LAYOUT, PAPER TYPE, PRINT QUALITY, DATE PRINT, and FILE NAME imprint options, select the PRINTER SETUP menu.
1. In the PictBridge settings menu, move the **Joystick** up or down to select **PRINTER SETUP**.
 - The available options are listed: DEFAULT and CUSTOMIZE.
 - To change options, select CUSTOMIZE. To reset your settings back to default, select DEFAULT.
 2. Move the **Joystick** to the right and select **CUSTOMIZE** by moving **Joystick** up or down, then press the **Joystick(OK)**.
 - The CUSTOMIZE menu list will appear.
 3. In the CUSTOMIZE menu, you can set following options:

①

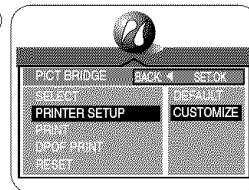

②

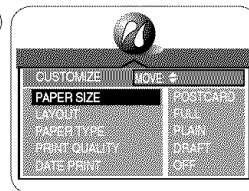

PAPER SIZE	POSTCARD, 4X6, 8X10, A6, A4, B5	You can select a paper size that is available from the printer.
LAYOUT	FULL, INDEX, 1, 2, 4, 6, 8	The option "1" has borders around. Others will not.
PAPER TYPE	PLAIN, PHOTO, FASTPHOTO	Set the type according to the paper type you are using.
PRINT QUALITY	DRAFT, NORMAL, FINE	Finer setting will take more time to print.
DATE PRINT	OFF, ON	Date and Time imprint option.
FILE NAME	OFF, ON	File name imprint option.

4. After setting options, press the **MENU** button to exit the CUSTOMIZE menu screen.
 - It will return to the PictBridge settings screen.

[Notes]

- The INDEX option of LAYOUT will print thumbnail images of all the selected images.
- Unsupported menu items are displayed on the LCD screen as deactivated.
- INDEX printing over many files (exceeding 10) using PictBridge may take long period of time. For faster INDEX printing, use the DPOF INDEX printing (see page 142) or thumbnail printing on a PC.

Digital Still Camera Mode : Advanced Techniques

Printing Images

- ❖ After selecting images and the PRINTER SETUP settings, print your images by choosing the PRINT menu.
 1. In the PictBridge settings menu, move the **Joystick** up or down to select **PRINT**.
 - The available options are listed: STANDARD and INDEX.
 2. Move the **Joystick** to the right.
 3. Select the desired option moving the **Joystick** up or down, then press the **Joystick(OK)**.
 - If STANDARD is selected, standard image printing will start.
 - If INDEX is selected, index printing on all the selected images will start.
 4. Progress Bar will be displayed.
 5. To cancel the printing, press the **MENU** button.
 - If there is no selected image, **NO IMAGE** message will be displayed. In that case, to go back to the PictBridge main menu page, press the **Joystick(OK)**.
 6. After successfully printing images, the PictBridge settings menu will be displayed.

[Notes]

- If there is no selected image to print, the **NO IMAGE** message appears on the LCD screen.
- If there is an error in the image, the **FILE ERROR** message appears on the LCD screen.
- If an unrecoverable error occurred during printing, **ERROR** is displayed. Press the MENU button to return to the PictBridge main menu.
- If a recoverable error occurs during printing, a **WARNING** message will be displayed with the RESUME and CANCEL options. Press the Joystick(OK) to select RESUME, then printing continues. Move the Joystick to the left to select CANCEL, which stops the printing.

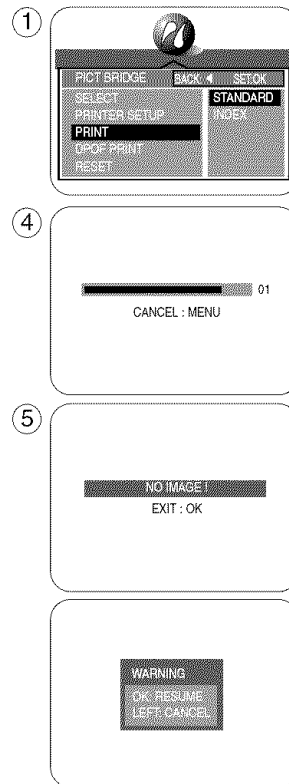

Digital Still Camera Mode : Advanced Techniques

Printing Images Using DPOF (Digital Print Order Format) Settings

- ❖ DPOF PRINT requires at least one DPOF marked image on the memory card.
1. Set the DPOF settings as described in page 141.
 2. Connect your Camcorder and the printer as described in page 136.
 - The PictBridge settings menu is displayed.
 3. Move the **Joystick** up or down to select **DPOF PRINT**, then move the **Joystick** to the right.
 - The available options are listed: YES and NO.
 4. Select **YES** by moving the **Joystick** up or down, then press the **Joystick(OK)** to start printing.
 - DPOF printing starts to print images and the progress bar is displayed.
 5. To cancel the printing, press the **MENU** button.

Resetting PictBridge Settings

1. Move the **Joystick** up or down to select **RESET**, then move the **Joystick** to the right.
 - The available options of YES and NO are displayed.
2. Select the desired option by moving the **Joystick** up or down, then press the **Joystick(OK)**.
 - If YES is selected, changes made by the user are reset to the default settings.

[Notes]

- If no image is marked for DPOF, DPOF PRINT in PictBridge settings menu cannot be selected.
- PictBridge supporting printers are commercially available.
- Use the USB cable provided with the Camcorder.
- Use the AC power adapter for your Camcorder during PictBridge Direct Printing. Turning your Camcorder off during the printing might damage data on the memory card.
- Printing still images is supported. Moving images are not available for printing.

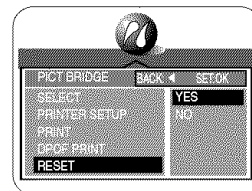
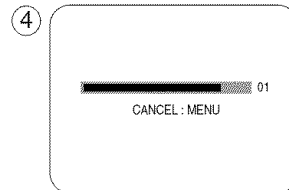
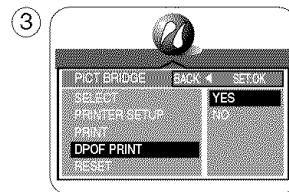

Digital Still Camera Mode : Advanced Techniques

Printing Your Images – Using the DPOF (Digital Print Order Format)

- ❖ DPOF menu only works in ▶(Play) mode.
- ❖ Mark your images with DPOF (Digital Print Order Format) marking to utilize automatic printing.
- ❖ You can mark your images with DPOF in 3 ways: STANDARD, INDEX and PRINT SIZE.

Before you begin!

- ❖ Set the **Power** switch to  (CAMERA).
- ❖ Set the **Mode Dial** to ▶(Play).

Standard DPOF Setup

1. Press the **MENU** button, then select  (DPOF) by moving the **Joystick** to the left or right.
 - The DPOF menu list will appear.
2. Move the **Joystick** up or down to select **STANDARD**, then move the **Joystick** to the right.
 - The available options of SELECT and ALL PICs are displayed.
3. Select the desired option by moving the **Joystick** up or down, then press the **Joystick(OK)**.
4. If SELECT is selected, the multiple images screen is displayed and the current selection is highlighted with a yellow outline. To set the DPOF print selection, move the **Joystick** to select an image, then press the **MENU** button. To change the number of copies, use the Zoom Lever to set the quantity.
 - Print mark and selected number of copies are displayed. To cancel the selection, press the **MENU** button again while it is highlighted in a yellow outline. To exit the selection screen, press the **Joystick(OK)**.
5. Press the **Joystick(OK)** to set your choice and exit the multiple images screen.
 - If ALL PICs is selected, number of prints setting menu is displayed.
 Move the **Joystick** up or down to set the number of prints. To exit the multiple images screen, press the **Joystick(OK)**.
 - To cancel your selection made, select CANCEL from the DPOF menu, then move the **Joystick** to the right.
 Select STANDARD, then press the **Joystick(OK)** to cancel your selection.

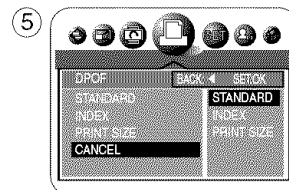
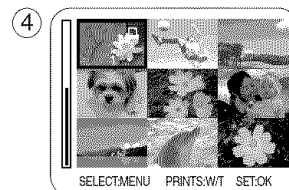
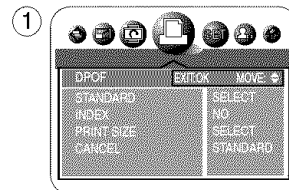

Digital Still Camera Mode : Advanced Techniques

Index DPOF Setup

- Press the **MENU** button, then select  (DPOF) by moving the **Joystick** to the left or right.
 - The DPOF menu list will appear.
- Move the **Joystick** up or down to select **INDEX**, then move the **Joystick** to the right.
 - The available options of NO and YES are displayed.
- Select the desired option by moving the **Joystick** up or down, then press the **Joystick(OK)**.
 - If YES is selected, all the images stored in the memory card will be marked for thumbnail printing.
- To cancel your selection made, select **CANCEL**, then move the **Joystick** to the right. Select **INDEX**, then press the **Joystick(OK)** to cancel your selection.

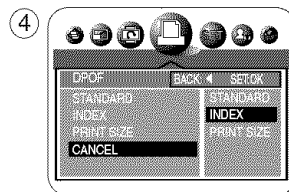
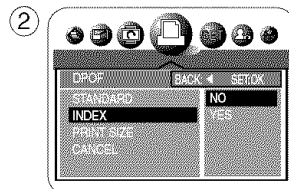

Print Size DPOF Setup

- Press the **MENU** button, then select  (DPOF) by moving the **Joystick** to the left or right.
 - The DPOF menu list will appear.
- Move the **Joystick** up or down to select **PRINT SIZE**, then move the **Joystick** to the right.
 - The available options of SELECT and ALL PICs are displayed.
- Select the desired option by moving the **Joystick** up or down, then press the **Joystick(OK)**.
- If **SELECT** is selected, multiple images screen is displayed and the current selection is highlighted with a yellow outline. To set the DPOF print selection, press the **MENU** button. To change the size, use the Zoom Lever.
 - Print mark and selected print size are displayed.
 - To cancel the selection, press the **MENU** button again while it is highlighted in a yellow outline.

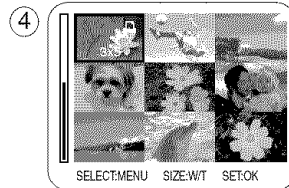
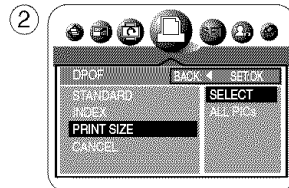

Digital Still Camera Mode : Advanced Techniques

- If ALL PICs is selected, print size setting menu is displayed. Move the **Joystick** up or down to set the print size.
 - To cancel your selection made, select **CANCEL**, then move the **Joystick** to the right. The available options of STANDARD, INDEX, and PRINT SIZE are available. Select **PRINT SIZE**, then press the **Joystick(OK)** to cancel your selection.
5. Press the **Joystick(OK)** to set your choice and exit the multiple images screen.

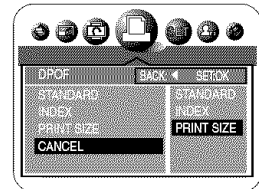
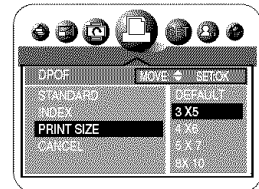

Printing DPOF Marked Images

- ❖ You can print out DPOF marked images using PictBridge menu if the printer supports PictBridge (see page 136).
- ❖ You can print out DPOF marked images by inserting your memory card directly to a DPOF supporting printer that has memory card interface. Or, you can connect your Camcorder using USB cable to a printer that supports DPOF printing. Refer to printer's documentation for further details.

[Note]

DPOF supporting printers are commercially available.

Maintenance

Cleaning and Maintaining the Camcorder

❖ For prolonged use of your device, read following instructions carefully.

After Using Your Camcorder

- For the safekeeping of your device, follow these steps.
 - Remove the cassette (see page 38).
 - Turn your camcorder off.
 - Remove the Battery.
 - Remove the Memory Card (see page 83)
- To prevent any damage to the LCD screen, do not apply excessive force on its moving parts.
- Do not drop or in anyway shock the device.
- For prolonged use of your device, avoid using it in places subject to excessive humidity or dust.
- Do not leave your device in places subject to:
 - Excessive humidity, steam, soot or dust
 - Excessive shock or vibration.
 - Extremely high (over 50°C or 122°F) or extremely low (under 0°C or 32°F) temperatures.
 - Strong electromagnetic fields.
 - Direct sunlight or in a closed car on a hot day.
- The cassette should be stored away from heaters and other heat sources. Avoid storing cassettes under direct sunlight, and avoid electromagnetic fields.
- The removed Battery Packs should be stored away from heaters and other heat sources. Do not store the battery pack with metal objects or sharp objects to avoid accidental damage to the battery pack.
- The memory card should be stored away from heaters and other heat sources. Avoid storing memory cards under direct sunlight, and avoid electromagnetic fields. Before removing the memory card from your device, move or copy your data from the memory card to a PC. Format the memory card periodically.

Cleaning For LCD Screen

We recommended using a soft cleaning cloth to remove fingerprints or dust on the LCD screen.

Maintenance

Cleaning the Camera Body and Video Heads

■ To Clean the Exterior of Your Device

- To clean the exterior, use a soft dry cloth. Wipe the body gently. Do not apply excessive force when cleaning, gently rub the surface.
- The LCD screen surface should not be pressed. Use a soft dry cloth to clean the surface.
- To clean the lens, use an optional air blower to blow out dirt and other small objects. Do not wipe the lens with cloths or your fingers. If necessary, use lens cleaning paper.
- Do not use chemicals, alcohol or benzene for cleaning. Otherwise, the finish may be damaged.
- Cleaning should be done only after the battery pack has been removed, and other power sources have been disconnected.

■ To Clean the Video Heads

- Dirty heads might cause problems with noisy recording and playback.
- To ensure normal operation of the video heads, avoid using in places subject to heavy dust.
- Avoid excessively frequent fast forwarding and rewinding of cassettes to avoid damaging the video heads.
- Excessive use of a cleaning cassette is not recommended.
- Use an optional cleaning cassette for video head cleaning. Periodic check-ups are recommended.
 1. Load the Cleaning Cassette.
 2. Set the Power Switch to PLAY mode.
 3. Press the ►/II (PLAY/STILL) button to start cleaning.
 4. Stop playing after 10 ~ 20 seconds.

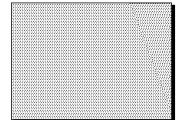
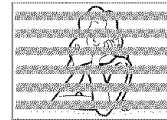

[Notes]

- Some cleaning cassette products stop automatically. Refer to the cleaning cassette's instructions for detailed information. If the problem continues after the cleaning, consult your nearest Samsung dealer or Authorized Service Center.
- Do not use wet-type cleaning cassettes.

Maintenance

Using Your Camcorder Abroad

- ❖ Each country or region has its own electric and color systems.
- ❖ Before using your camcorder abroad, check the following items:

Power Sources

You can use your camcorder in any country or area with the supplied AC Power Adapter where the power input range is 100V ~ 240V, 50/60Hz.

Use a commercially available AC plug adapter if necessary, depending on the design of the local wall outlets.

Color System

You can view your recordings using the built-in LCD screen and viewfinder.

However, to view your recordings on a television set or to copy it to a video cassette recorder (VCR), the television set or the VCR must comply with NTSC-compatible and have the appropriate Audio / Video ports. Otherwise, you may need to use a separate Video Format Transcoder (NTSC-PAL format Converter).

PAL-Compatible Countries / Regions

Australia, Austria, Belgium, Bulgaria, China, CIS, Czech Republic, Denmark, Egypt, Finland, France, Germany, Greece, Great Britain, Holland, Hong Kong, Hungary, India, Iran, Iraq, Kuwait, Libya, Malaysia, Mauritius, Norway, Romania, Saudi Arabia, Singapore, Slovak Republic, Spain, Sweden, Switzerland, Syria, Thailand, Tunisia, etc.



NTSC-Compatible Countries / Regions

Bahamas, Canada, Central America, Japan, Mexico, Philippines, Korea, Taiwan, United States of America, etc.

Troubleshooting



- ❖ If your device fails to function as expected, please check the following before contacting service personnel. Refer to the page numbers listed for further details.

Self Diagnosis Display



Display	Blinking	Informs that...	Action
	Slow	The battery pack is almost discharged	Change to a charged one or connect to other power source
TAPE END!	Slow	When the remaining time on the tape is less than 2 minutes	Prepare a new cassette
TAPE END!	No	Cassette has reached its end	Change to a new cassette
TAPE!	Slow	No cassette tape is inserted	Insert a tape
PROTECTION!	Slow	The tape is Record Protected	Change to a new cassette or release the tape record protection
▲ D L C R	Slow	Camcorder has a mechanical fault	<ol style="list-style-type: none"> 1. Eject the cassette tape. 2. Set to off 3. Detach the battery. 4. Restart the camcorder If problem continues, contact your local service representative.
	Slow	Moisture condensation	See page 9
NO CARD!	Slow	No memory card is inserted	Insert a memory card
CARD FULL!	Slow	Not enough space for saving images	Change to a new memory card or delete recorded images
NO IMAGE!	Slow	There are no images recorded to play	Record a new still image
FILE ERROR!	Slow	The image file has an error	Delete the image or format the memory card
CARD ERROR!	Slow	Memory card is formatted by other device or has error in system folder	Format the memory card using the Camcorder menu
NOT FORMATTED !	Slow	The Memory Card needs to format.	Format a Memory Card. (see page 135)

Troubleshooting

✦ If these instructions do not solve your problem, contact your nearest Samsung dealer or authorized service center/personnel.

Symptom	Possible Causes	Measure
No power is supplied	The power is not connected properly The battery is dead The battery is too cold	Connect the AC adapter properly, page 22 Replace the dead battery pack Warm up the battery or move to warmer place
LCD screen is blank	Viewfinder is on. Multi-AV cable is connected Display option is turned off	Close the viewfinder Remove the cable Press the DISPLAY button to bring back OSD
DATE/TIME is wrong	The DATE/TIME is not set The built-in clock battery is exhausted	Set the DATE/TIME, page 35 Replace the Lithium ion battery for built-in clock, page 21
Cannot Record a video	Protection tab is set to "SAVE" Power switch is set to PLAY Power switch is set to  (CAMERA)	Cancel the protection, page 38 Set the Power Switch to REC Set the Mode Dial to  (Movie) mode
Focus does not adjust automatically	Focus is set to manual mode Recording was done in a dark place Lens is covered with condensation	Set focus to AUTO Use flash or light the location Clear the lens and check the focus
Cassette tape will not load properly	Cassette is in wrong position The battery is exhausted	Insert the cassette tape properly, page 38 Charge the battery or use AC adapter
The memory card will not load properly	Memory card is in wrong position Something fills in the memory card slot	Insert the memory card properly, page 83 Clear the memory card slot
Color balance of image is not natural	White balance adjustment is required	Set proper white balance, page 57, 119
Digital zoom does not work	Digital special effect is applied	Turn off the digital special effects. page 64
Files stored in the memory card cannot be deleted	Memory card is protected File is protected	Remove the memory card's protection tab Remove file protection, page 133

Troubleshooting

Symptom	Possible Causes	Measure
Images on the LCD screen appear dark	Ambient light is too bright Ambient temperature is too low	Adjust the brightness and angle of LCD Low temperatures might produce a dark LCD display. This is not a malfunction.
Rear of the LCD screen is hot	Prolonged use of LCD screen	Close the LCD screen to turn it off, or turn your device off to cool down.
Play, rewind and fast forwarding do not work	Power switch is set to REC	Set the Power switch to PLAY
Memory card cannot be played back (Camera mode)	Power switch is set to PLAY Mode	Set the Power switch to  (CAMERA) Mode and set the Mode Dial to  (Play) Mode
No image is taken when PHOTO is fully pressed	Not enough free memory space is remained Memory card is formatted by different devices	Delete files from the memory card Format the memory card
Built-in flash will not fire	Flash is forced to cancel Focus is set to infinity AE lock is enabled Recording moving images Continuous shot option is turned on Bracket shooting is enabled	Select different flash mode, page 108 Select AUTO, EASYQ, or different MF distance, page 110 Turn off the AE lock Flash is not available for moving images Turn off the continuous shot Turn off the AEB, page 123

Specifications

Model Name		SC-D6550
Camcorder System		
Video Signal	NTSC	
Video Recording System	2 Rotary heads, Helical Scanning System	
Audio Recording System	Rotary heads, PCM system	
Usable Cassette	Digital Video tape: 0.25 inch (6.35mm) MiniDV cassette	
Tape Speed	SP: approx. 0.74 inch/s(18.81mm/s), LP: approx. 0.5 inch/s(12.56mm/s)	
Tape Recording Time	SP: 60 minutes, LP: 90 minutes (when using DVM60)	
FF/REW time	Approx. 180 sec (when using DVM60)	
General	CAMCORDER	CAMERA
Format	MiniDV	JPEG (DCF)
Dimension (WxHxD)	60.5 X 77 X 125 (mm) / 2.4 X 3.0 X 4.9 (inches)	
Weight (Net)	440 g / 9.7 lb (Except the Lithium Ion Battery Pack and Tape)	
Power Consumption	4.3W (LCD on) / 4.0W (CVF on) for recordings	
Power Source	DC 8.4V, Li-Ion Battery pack: 7.4V	
Power Source Type	Lithium-ion battery pack, Power supply (100V ~ 240V, 50/60 Hz)	
Built-in Microphone	Omni-directional Stereo condenser microphone	
LCD screen		
Size	2.5"	
Pixel	112K, Trans Reflective	
LCD Frame Coverage	CAMCORDER	CAMERA
	-	88%
Bright / Color Adjust	YES / YES	
Rotation Angle	90 + 270 deg	
Mirror	YES	
Viewfinder		
Display Device	Color	
Size	0.3"	
Pixel	123K	
Diopter Adjust	YES	

- These technical specifications and design may be changed without notice.

Specifications

Lens	CAMCORDER	CAMERA
Optical Zoom Ratio	10x	3x
Digital Zoom Ratio	900x	12x
Focal Length (f)	2.4 ~ 24mm	7.7 ~ 23.1mm
F. No (Wide / Tele)	1.8 / 2.4	2.8 / 4.9
Zooming Speed	Variable 4 step	1 step
Filter Diameter	25	Not Available
Macro	Wide Macro	1.6~31.5 inches (Wide), 11.8~31.5 inches (Tele)
CCD	CAMCORDER	CAMERA
Size	1/6" Charge Coupled Device	1/2.5" Charge Coupled Device
Pixel (Max / Effective)	680K / 340K	5.25M/5.1M
Flash	NO	YES
Image Stabilizer	DIS	NO
Auto Focus / Manual Focus	YES / YES	YES / YES
Shutter Speed (Auto)	1/60 ~ 1/10,000	2 ~ 1/2,000
Manual Shutter Speed	1/60 ~ 1/10,000 8 step	Night Scene Mode, 15 ~ 1/2,000
Auto White Balance	YES	YES
Metering		TTL Automatic, 31.5 inch ~ infinity
Connectors		
Video output	1 Vp-p (75Ω terminated)	
S-VIDEO output	Y: 1 Vp-p, 75Ω C: 0.2861 Vp-p, 75Ω	
Audio output	7.5 dBs(600Ω terminated)	
DV input / output	4-pin IEEE1394	
USB output	Mini-B type	
External MIC	Ø 3.5 stereo	
Others		
Operating Temperature	0 ~ 42°C / 32 ~ 104°F	
Storage Temperature	-20 ~ 60°C / -4 ~ 140°F	

Index

.....	- A -	image size	87
Audio dubbing		74	- L -
Audio Mode		53	LCD	34
.....	- B -	Lithium battery	21
BLC		48	- M -
.....	- C -	Macro	46, 112
Cassette		38	Memory Stick	82
Cleaning and Maintaining the Camcorder		144	MF/AF	56, 110
Clock Set		30	MPEG Playback	106
Continuous Shot		124	MPEG Recording	104
.....	- D -	MPEG Size	104
Date/Time		35	- O -
Delete		102	OSD	25, 26, 27
Demonstration		33	- P -
Digital Zoom		66, 126	PHOTO	67
DIS		59	Playback	68
DSE		122	Power Source	22
.....	- E -	Power Switch	22
EASY.Q Mode		42	Print Mark	141
.....	- F -	Program AE	61
Fade In and Out		47	Protect	133
File Number		85	- Q -
Flash		108	Quick Review	100
Focus		56, 107	- R -
Folders and Files		84	Rec Mode	52
.....	- H -	Remote Control	19
Hand Strap		20	- S -
.....	- I -	Search	67
IEEE1394		76	Shutter Speed & Exposure	55
Image Quality		86	Slide Show	99

Index

Speaker	69
SPOT-AE	114
- T -	
Troubleshooting	147
TV Display	36
- U -	
USB	78
- V -	
Viewfinder	37
Viewing Still images	98
- W -	
White Balance	57, 119
Wind Cut	54
WL.Remote	92
- Z -	
ZERO MEMORY	44

Warranty (SEA users only)

SAMSUNG LIMITED WARRANTY

SAMSUNG Electronics America Inc. (SEA), warrants that this product is free from defective material and workmanship. SEA further warrants that if product fails to operate properly within the specified warranty period and the failure is due to improper workmanship or defective material, SEA will repair or replace the product at its option.

All warranty repairs must be performed by a SEA authorized service center. The name and address of the location nearest you can be obtained by calling toll free: 1-800 SAMSUNG (1-800-726-7864).

Labor

90 days carry-in

Parts

1 year

On carry-in models, transportation to and from the service center is the customer's responsibility.

The original dated sales receipt must be retained by the customer and is the only acceptable proof of purchase.

It must be presented to the authorized service center.

EXCLUSIONS (WHAT IS NOT COVERED)

This warranty does not cover damage due to accident, fire, flood and/or other acts of God; misuse, incorrect line voltage, improper installation, improper or unauthorized repairs, commercial use, or damage that occurs in shipping.

Exterior and interior finish, lamps, and glass are not covered under this warranty.

Customer adjustments which are explained in the instruction manual are not covered under the terms of this warranty.

This warranty will automatically be voided for any unit found with a missing or altered serial number. This warranty is valid only on products purchased in the United States and Puerto Rico.

Some States do not allow the exclusions or limitations of incidental or consequential damages, or allow limitations on how long an implied warranty lasts, so the above limitations or exclusions may not apply to you.

This warranty gives you specific legal rights, and you may also have other rights which vary from State to State.

Memo

ENGLISH

THIS CAMCORDER IS MANUFACTURED BY:



SERVICE DIVISION
400 Valley Road, Suite 201, Mt. Arlington N.J. 07856
Tel: 1-800-SAMSUNG
(1-800-726-7864)

***Samsung Electronics' Internet Home Page**

<http://www.samsung.com>

AD68-00875G