

Installation Instructions

PGF, PGC, PGS, GPFM, GPCM, GPSM
1¹/₂ to 5 TON

**COMBINATION UNITS
GAS HEAT / ELECTRIC COOL**

1. Safety Labeling and Signal Words

Danger, Warning and Caution

The signal words **DANGER**, **WARNING** and **CAUTION** are used to identify levels of hazard seriousness. The signal word **DANGER** is only used on product labels to signify an immediate hazard. The signal words **WARNING** and **CAUTION** will be used on product labels and throughout this manual and other manuals that may apply to the product.

Signal Words

DANGER - Immediate hazards which **WILL** result in severe personal injury or death.

WARNING - Hazards or unsafe practices which **COULD** result in severe personal injury or death.

CAUTION - Hazards or unsafe practices which **COULD** result in minor personal injury or product or property damage.

Signal Words in Manuals

The signal word **WARNING** is used throughout this manual in the following manner:

WARNING

The signal word **CAUTION** is used throughout this manual in the following manner:

CAUTION

Product Labeling

Signal words are used in combination with colors and/or pictures on product labels. Following are examples of product labels with explanations of the colors used.

Danger Label

White lettering on a black background except the word **DANGER** which is white with a red background.

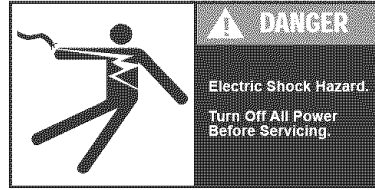

Warning Label

White lettering on a black background except the word **WARNING** which is black with an orange background.

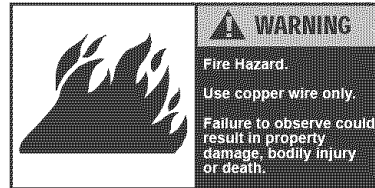

Caution Label

White lettering on a black background except the word **CAUTION** which is black with a yellow background.

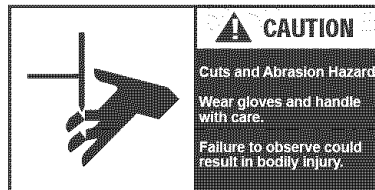

UNIT DIMENSIONS

1-1/2 TO 3-1/2 TON

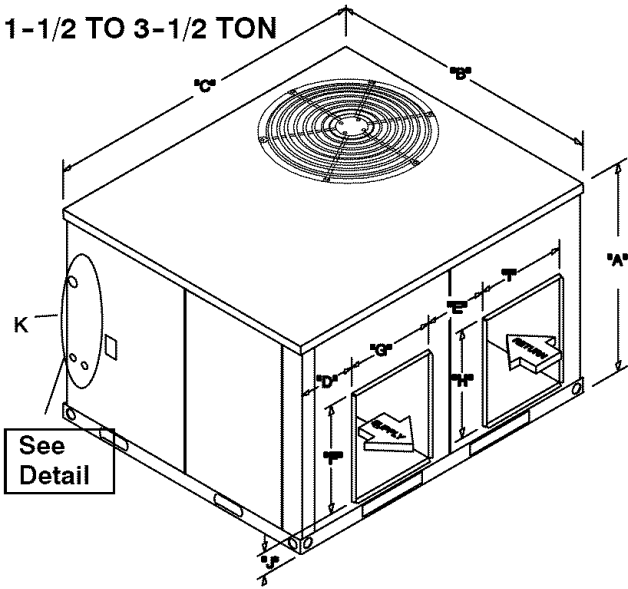

4 TO 5 TON

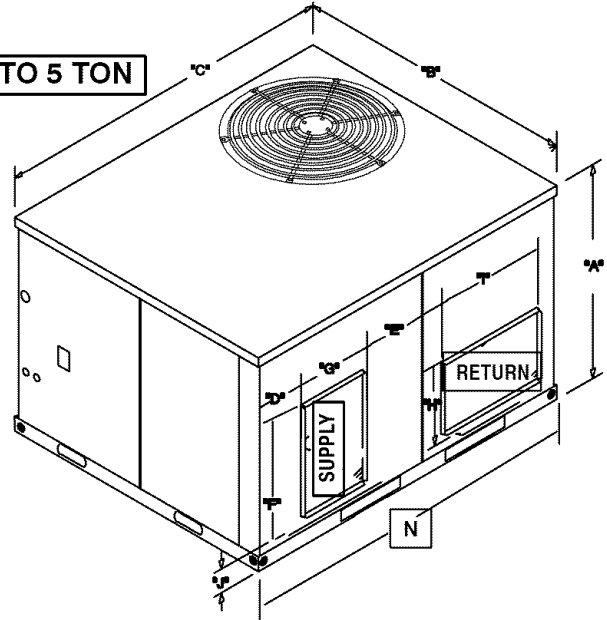

BASE PAN - CHASSIS

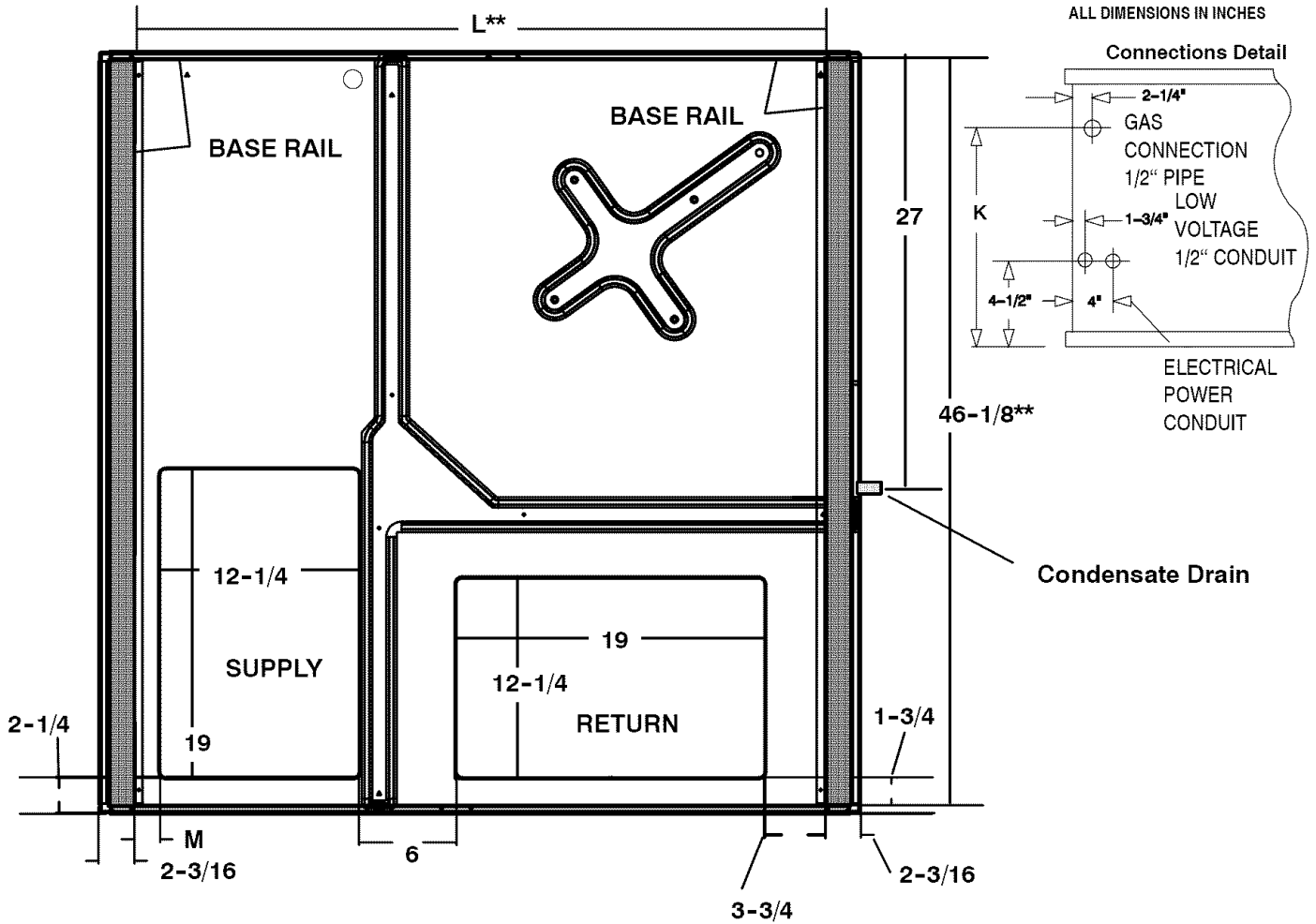

UNIT SIZE	A	B	C	D	E	F	G	H	I	J	K	L	M	N
1-1/2 TO 3-1/2 Ton	29-1/2	47-1/2	47-1/2	3	9-1/2	12	14	12	14	4-1/2	16	42-3/4	1-9/16	46-1/2
4 TO 5 Ton*	37-1/2	47-1/2	51-1/2	7-1/2	6-1/2	19	12	12	19	4-1/2	22	46-1/4	5-3/16	49-3/4

** Measured from inside to inside on base rails.

3. SAFE INSTALLATION REQUIREMENTS

WARNING

Installation or repairs made by unqualified persons can result in hazards to you and others. Installation **MUST** conform with local building codes or, in the absence of local codes, with the ANSI Z223.1 and the National Electrical Code NFPA70-1990 or in Canada the National Standard CAN/CGA B149-1 and CSA C.22.1 - Canadian Electrical Code Part 1.

The information contained in this manual is intended for use by a qualified service technician familiar with safety procedures and equipped with the proper tools and test instruments.

Failure to carefully read and follow all instructions in this manual can result in furnace malfunction, property damage, personal injury and/or death.

- Do **NOT** use this furnace as a construction heater.
- Use only the Type of gas approved for this furnace (See **Rating Plate**).
- Do **NOT** use open flame to test for gas leak.
- Seal supply and return air ducts.
- Check to see that filters are installed correctly and are the proper type and size.

NOTE: It is the personal responsibility and obligation of the customer to contact a qualified installer to ensure that the installation is adequate and conforms to governing codes and ordinances.

CAUTION

It is recommended that a qualified service technician check the heat exchanger integrity every two (2) years, after the first four (4) years of operation.

4. LOCATING THE UNIT

ACCESS PANELS

See **FIGURE 1** for a general view of unit and location of access panels.

WARNING

Carbon monoxide poisoning hazard.

Keep blower door closed.

Failure to keep blower door closed can result in bodily injury and/or death.

CLEARANCES

The location **MUST** allow for minimum clearances and should not be adjacent to a patio or other area where the unit's operating sound level might be objectionable. The combustion air inlet openings **MUST** not be obstructed (see **FIGURE 1**). In addition, local codes **MUST** be observed.

NOTE: Units with available filter racks (3-1/2 to 5 ton), need a 26" minimum clearance at side of unit for removal of filters. See chart below if unit is going to be placed near combustible construction or materials.

While minimum clearances are acceptable for safety reasons, they may not allow adequate air circulation around the unit for proper operation in the cooling mode. Whenever possible, it is desirable to allow additional clearance, especially around the condenser inlet and discharge openings.

Do **NOT** install the unit in a location that will permit discharged air from the condenser to recirculate to the condenser inlet.

CAUTION

Do **NOT** operate unit in a corrosive atmosphere containing chlorine, fluorine, or any other corrosive chemicals.

Minimum Clearances to Combustible Construction

Furnace Plenum	2"
Duct Side	2" (6" on large chassis models)
Condenser Inlet	30"
Blower Service (Side)	30"
Control Service Side	
(Front Combustion Air Inlet)	30"
Clearance between 3 Ft. Overhang	
and Top of Unit	30"
Combustible Base	
(Wood or Class A, B or C	
roof covering material)	0"

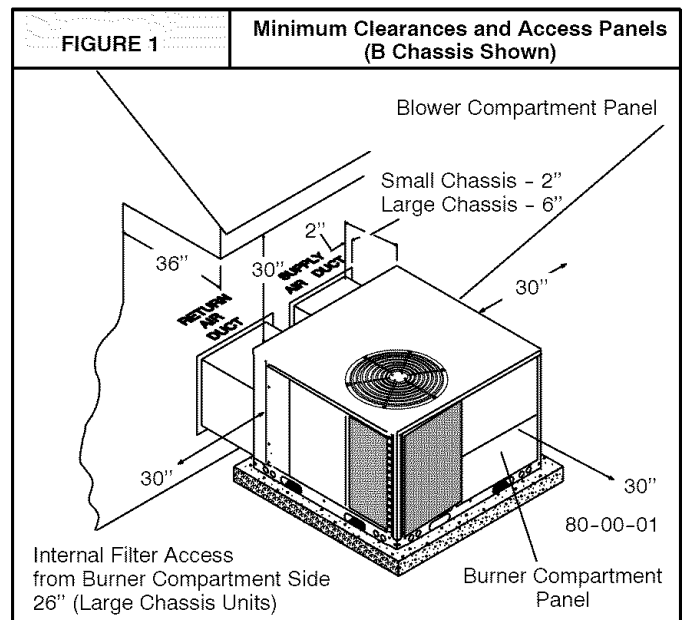

INSTALLATION

NOTICE

Unit will **NOT** operate properly unless it is installed level front to rear and side to side. The slope **MUST NOT** be greater than 1/8" per foot (10mm per meter). For side to side leveling, the drain side **MUST** always be lower.

Ground Level Installation

Ground level platform requirements:

- The unit **MUST** be situated to provide safe access for servicing.
- Platform may be made of either concrete or pressure treated wood and **MUST** be level and strong enough to support unit weight.
- Position platform separate from building foundation.
- Install in well-drained area, with top surface of platform above grade level.
- Platform must be high enough to allow for proper condensate trap installation and drainage. See **FIGURE 3** and associated text for more information about condensate drainage.

Rooftop Installation

Rooftop platform requirements:

- The unit **MUST** be situated to provide safe access for servicing.
- The existing roof structure **MUST** be adequate to support the weight of the unit or the roof **MUST** be reinforced. Check the weight of the unit in relation to the roof structure and local building codes or ordinances and reinforce roof structure if necessary. See the last page of this manual for unit weights.
- Support for the unit **MUST** be level and strong enough to carry unit weight. The support may consist of a platform or a combination of platform and roof beams or curb.
- See *Hoisting* section for hoisting instructions.

HOISTING

NOTE: All access panels **MUST** be secured in place before hoisting.

The unit should be hoisted with two lifting slings. Attach the slings to rigging shackles that have been hooked through holes in the base rail.

Two spreader bars **MUST** be placed on top of the unit to protect the unit from damage from the pressure exerted by the slings. Make sure that all equipment is adequate to handle the weight of the unit and that the slings will not allow the unit to shift.

Refer to **FIGURE 17** on the back cover of this manual for illustrated rigging instructions and weight chart.

DOWNFLOW CONVERSION

NOTE: In downflow applications with roof curbs or jack stands, the center rail under the unit must be removed. The center rail is attached to the base rail with screws.

These units are adaptable to downflow use. To convert to downflow use, follow these steps:

1. Remove the blockoff plates found in the return air compartment and the supply air compartment.

NOTE: Blockoff plate in the supply air compartment only contains one screw. If reinstalling plate, back part of plate **MUST** fit into mating dimples on flange. To reinstall, slant plate into dimples, then put plate into position and fasten with screw.

2. Install the removed plates on the horizontal return and supply air openings.
3. Install roof curb on the building. Be sure to follow all directions included with curb and all applicable building codes in your installation.

Heating Vent Assembly

Refer to **FIGURE 2** and assemble as shown.

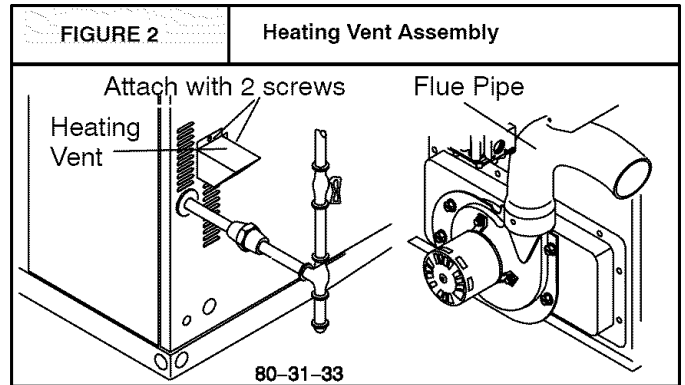

CAUTION

DO NOT OPERATE THE UNIT WITHOUT THE VENT ASSEMBLY INSTALLED

Condensate Drain

The condensate drain outlet is a $\frac{3}{4}$ " (19.1mm) female PVC connection located at the bottom on the left hand side (see **FIGURE 3**).

The circulating blower creates a negative pressure on the condensate drain line that can prevent the condensate from draining properly. To combat this negative pressure, a field supplied condensate trap that will allow a standing column of water of at least 2" (50.8mm) **MUST** be installed. Top of outlet from trap **MUST** be at least 1" (25.4mm) below top of outlet from unit. **Install the trap as near to the unit as possible for proper drainage.**

A $\frac{3}{4}$ " (19.1mm) drain line **MUST** be installed if required by local codes or if location of unit requires it. Run the drain line to an open drain or other suitable disposal point.

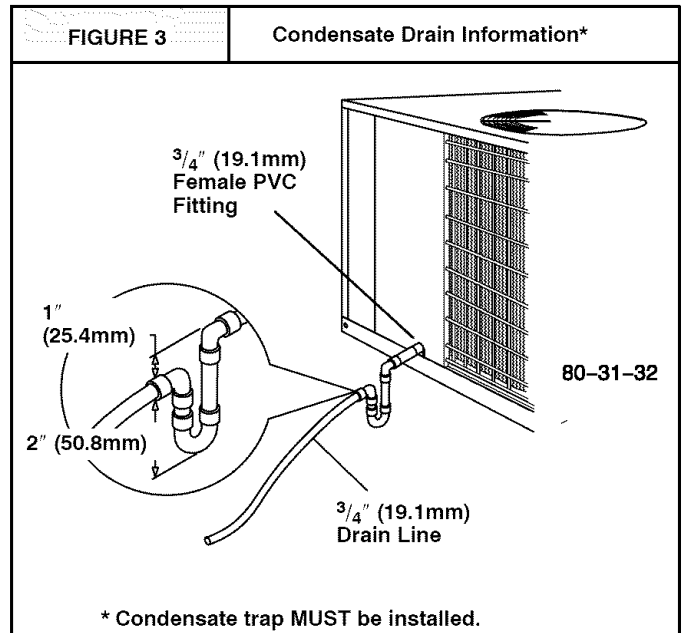

* Condensate trap **MUST** be installed.

5. PRE-EXISTING COMMON VENT CHECK

If the installation of the combination unit involves removing an existing furnace from a common vent with other appliances, the existing venting system will probably be too large for the remaining appliances and they will not vent properly. The existing venting system **MUST** be checked by a qualified technician to ensure it is properly sized and vents properly.

6. GAS SUPPLY AND PIPING

NOTE: Because there are many types of liquified petroleum (LP) gases, the term LP as used in this manual refers to propane gas. If you intend to use any type of LP gas, proper precautions **MUST** be used in the handling, piping, and use of such gas. **NOTE:** In Canada, installations **MUST** be performed by licensed LP installers.

The UL/CSA Rating Plate located on the side panel on the unit contains the model number, type of gas and gas input rating, and other important information.

WARNING

Fire and/or explosion hazard.

Make certain the unit is equipped to operate on the type of gas available. Models designated as natural gas are to be used with natural gas only. Models designated for use with liquefied petroleum (LP) gas are shipped with orifices sized for commercially pure propane gas. They **MUST** not be used with butane or a mixture of butane and propane unless properly sized orifices are installed by a licensed LP installer.

Failure to follow this warning can result in property damage, personal injury, and/or death.

GAS PIPING

The gas supply line **MUST** be of adequate size to handle the Btu/hr requirements and length of the run for the unit being installed. Determine the minimum pipe size for natural gas from the table in **FIGURE 4** or **FIGURE 5**. Base the length of the run from the gas meter or source to the unit.

Gas Pipe Size

Btu ratings of all other gas appliances **MUST** be considered for sizing of main gas line. Check gas line to installation for compliance with local codes or, in the absence of local codes, with the National Fuel Gas Code ANSI Z223.1 or in Canada the National Standard CAN/CGA B149-1 or current editions.

FIGURE 4		Gas Pipe Size, Length and Btu/hr Capacity for Schedule 40 Iron Pipe (English)				
NATURAL GAS						
Pipe Length (Includes Fittings)	Btu/hr (in thousands)					
	3/4"	1"	1 1/4"	1 1/2"	2"	
20'	190	350	730	1,100	2,100	
40'	130	245	500	760	1,450	
60'	105	195	400	610	1,150	
LP GAS						
Pipe Length (Includes Fittings)	Btu/hr (in thousands)					
	1/2"	3/4"	1"	1 1/4"	1 1/2"	
20'	189	393	732	1,496	2,299	
40'	129	267	504	1,039	1,559	
60'	103	217	409	834	1,275	

FIGURE 5		Gas Pipe Size, Length and Btu/hr Capacity for Schedule 40 Iron Pipe (English)				
NATURAL GAS						
Pipe Length (Includes Fittings)	kW**					
	3/4"	1"	1 1/4"	1 1/2"	2"	
6.1m	56	103	214	322	615	
12.2m	38	72	147	223	425	
18.3m	31	57	117	179	337	
LP GAS						
Pipe Length (Includes Fittings)	kW**					
	1/2"	3/4"	1"	1 1/4"	1 1/2"	
6.1m	55	115	215	438	674	
12.2m	38	78	148	305	457	
18.3m	30	64	120	244	374	

**kW (Kilowatts) is the metric equivalent of Btu/hr.

PIPING AT UNIT

Connections

NOTE: The rules listed apply to natural and LP gas pipe installations.

1. If installation is for LP gas, have LP gas installer use **TWO-STAGE REGULATION** and make all connections from storage tank to unit.
2. Use black iron or steel pipe and fittings or other pipe approved by local code.
3. If copper tubing is used, it **MUST** comply with limitation set in Fuel Gas Code.

NOTE: If a gas connector is used, it **MUST** be acceptable to local authority. Connector **MUST NOT** be used inside the furnace or be secured or supported by the furnace or ductwork.

WARNING

Fire and/or explosion hazard.

Gas connector **MUST** be properly installed and can **NOT** be used inside the furnace.

Failure to do so can result in property damage, bodily injury or death.

4. Use pipe joint compound on external (male) threads **ONLY**. Joint compound **MUST** be resistant to any chemical action of LP gases (**NO TAG**). Do **NOT** put pipe compound on last 2 threads of pipe.
5. Use ground joint unions and install a drip leg no less than 3 inches (76 mm) long to trap dirt and moisture before it can enter gas valve.

CAUTION

Overtightening assembly may cause damage to the gas valve and/or wiring and may misalign the burners.

6. Use a wrench on gas valve when making connections to prevent gas valve from turning. Do **NOT** use a pipe wrench on the gas valve body.
7. Provide a 1/8 inch (3mm) National Pipe Thread (NPT) plug for test gauge connection immediately upstream of the gas supply connection to the furnace if none is supplied with the gas valve of unit.

8. Install a manual shutoff valve and tighten all joints securely.
9. Make sure pilot tube and burner orifices are checked for leakage.

ORIFICES

Orifice Sizes

Orifice sizes **MUST** be matched to the heating value of the gas (see **FIGURE 6 AND TABLE 1**). Check with your gas supplier and the National Fuel Gas Code ANSI Z223.1.

NOTE: An LP Conversion Kit **MUST** be used for conversion to LP gas.

NOTE: For elevations above 2000 feet (610 meters), the Btu input rating **MUST** be reduced by 4% for each 1000 feet (305 meters) above sea level, unless the gas supplier's Btu/ft³ content has already been adjusted for altitude. Check **Table 1** for the proper orifice sizes.

FIGURE 6		Orifice Sizes	
Gas Type	Specific Gravity	Btu/ft ³ (kJ/L)	Pilot Orifice Sizes
Natural	0.6	1000	.018#
Propane	1.53	2500	.012#

#Adjust pilot flame as needed

TABLE 1: Equivalent Orifice Sizes at High Altitudes
(Includes 4% input reduction for each 1,000 ft.)

Natural Gas Manifold Orifice Size Required by Elevation								
BTU INPUT	0'-2000'	2000'-4000'	4500'-5000'	6000'	7000'	8000'	9000'	10000'
40,000	45	46	47	48	48	49	49	50
60,000	45	46	47	48	48	49	49	50
80,000*	41	42	43	43	44	44	45	46
80,000**	45	46	47	48	48	49	49	50
100,000	42	43	43	44	44	45	46	47
120,000	42	43	43	44	44	45	46	47
140,000	42	43	43	44	44	45	46	47

LP Gas Manifold Orifice Size Required by Elevation								
BTU INPUT	0'-2000'	2000'-4000'	4500'-5000'	6000'	7000'	8000'	9000'	10000'
40,000	56	57	57	57	58	59	59	60
60,000	56	57	57	57	58	59	59	60
80,000*	54	55	55	55	55	56	56	56
80,000**	56	57	57	57	58	59	59	60
100,000	54	55	55	55	58	56	56	56
120,000	54	55	55	55	55	56	56	56
140,000	54	55	55	55	55	56	56	56

* 2-1/2 & 3 Ton with 3 burners.
** 3-1/2 & 4 ton with 4 burners.

Changing Orifices

WARNING

Electrical shock, fire and/or explosion hazard.

Shut off electric power at unit disconnect or service panel and shut off gas at manual shut off valve before beginning the following procedure.

Changing orifices requires a qualified service technician.

Failure to follow this warning can result in property damage, personal injury, and/or death.

1. Shut **OFF** gas at manual shut off valve.
2. Shut **OFF** electric power at unit disconnect or service panel. If unit is still running, allow 2.5 minutes after gas shut off before turning off power.
3. Disconnect the wires from the gas valve and disconnect pilot tubing from valve.
4. Remove the four screws holding the manifold to the manifold brackets.
5. Carefully remove the manifold with the gas valve attached.
6. Remove the orifices from the manifold with a 7/16" box end or socket wrench.
7. Check to be sure that the size of each orifice is correct for the Btu input desired.

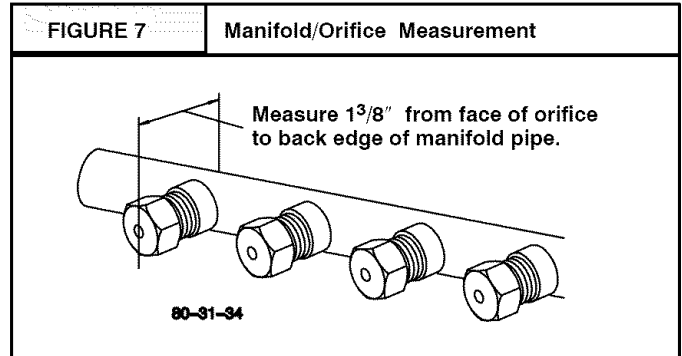

8. Install the correct orifices. Gauge the size of the orifices with a new twist drill bit of the correct size.

Make sure that the orifices go in straight so that they form a right angle (90°) to the manifold pipe.

Tighten the orifices so that there is a 1 3/8" distance between the faces of the orifices to the back of the manifold pipe.

Measure the distance with a set of calipers. If you do not have a calipers, you can use an adjustable wrench and measure between the face of the jaws.

9. Reassemble in reverse order.

7. ELECTRICAL WIRING

WARNING

Electrical shock hazard.

Disconnect power at fuse box or service panel before making any electrical connections.
Unit **MUST** be grounded to electrical service panel.

Failure to follow this warning can result in property damage, personal injury, and/or death.

NOTE: All electrical work **MUST** conform with the requirements of local codes and ordinances and the National Electrical Code ANSI/NFPA-No. 70-1990 or current edition. Provide line voltage power supply from a separate fused circuit with a disconnect switch located within sight of the unit.

For access, remove the burner access panel. See **FIGURE 1** for access panel location. Wiring **MUST** be protected from possible mechanical damage.

Line Voltage Wiring

Connections for line voltage are made in the unit control box area. For access, remove the burner access panel.

Ground Connections

Do **NOT** complete line voltage connections until unit is permanently grounded. All line voltage connections and the ground connection **MUST** be made with copper wire.

A ground lug is installed in the control box area for the ground connection. Use a copper conductor of the

appropriate size from the unit to a grounded connection in the electrical service panel or a properly driven and electrically grounded ground rod. See warning above.

Line Connections

Complete the line service connections to the contactor 'L' terminals inside the control box area. Refer to applicable wiring diagram. Check all screw terminals to ensure they are tight.

THERMOSTAT/HEAT ANTICIPATOR

The location of the thermostat has an important effect on the operation of the unit. **FOLLOW THE INSTRUCTIONS INCLUDED WITH THE THERMOSTAT FOR CORRECT MOUNTING AND WIRING.**

Set the thermostat heat anticipator in accordance with thermostat instructions.

Final Electrical Check

1. Make a final wiring check to be sure system is correctly wired. Inspect field installed wiring and the routing to ensure that rubbing or chafing due to vibration will not occur.

NOTE: Wiring **MUST** be installed so it is protected from possible mechanical damage.

8. DUCTWORK

Maximum recommended velocity in trunk ducts is 1000 feet per minute. Velocity in branches should not exceed 800 feet per minute.

FIGURE 8		Capacities Air Delivery		
Nominal Tons Air Conditioning	Nominal Air Flow Cubic Feet per Minute	Recommended Filter Sizes Sq. In. Surface Area/Nominal Size		Unit Size Heating Input 1000 x Btuh
		Disposable Filters	Cleanable Filters	
Up Thru 2	800-900	400 or 20 x 25	246 or 15 x 20	40 and 60
2 1/2	900-1100	487 or 20 x 30	301 or 14 x 25	60 and 80
3	1100-1300	576 or 14 x 25 (2Req.)	356 or 16 x 25	60, 80 and 100
3 1/2	1300-1500	665 or 16 x 25 (2Req.)	411 or 20 x 25 (2Req.)	80 and 100
4	1500-1700	753 or 20 x 25 (2 Req.)	466 or 20 x 25	80 and 120
5	1900-2100	960 or 20 x 30 (2 Req.)	575 or 24 x 25	100 and 140

Minimum recommended filter areas are based on a velocity of 325 ft./min. for disposable filters and 525 ft./min. for high velocity filters (washable).

NOTE: Ductwork sizing affects temperature rise and cooling temperature differential. Be sure to properly size ductwork to the capacity and airflow characteristics of your unit. Failure to do so can affect limit controls, compressors, motors, and other components and will lead to premature failure of components. This will also adversely affect day to day unit performance. Refer to rating plate and *Temperature Rise Check*.

Combustion Blower Pipe Installation

Remove the combustion blower pipe from the right corner of burner compartment and position the end of the pipe with the screw hole over the opening of the combustion blower. The other end of the pipe should now be aligned through the opening in the side panel of unit. The pipe should slightly protude through the opening in the side panel.

Remove (1) chisle pointed #10 screw (self drilling) taped to the vent cap. Position the screw to the hole in the pipe and drill through the combustion blower outlet securing the pipe to the combustion blower.

Ductwork Insulation

Ductwork installed outdoors should have a minimum of 2" fiberglass insulation and a weatherproof vapor barrier. It should be protected against damage. Caulking and flashings, or other means adequate to provide a permanent weather seal, should be used.

Ductwork installed in attics or other areas exposed to outside temperatures should be installed with a minimum of 2" fiberglass insulation and have an indoor type vapor barrier.

Ductwork Connections

The use of flexible, **non-combustible** connectors between main trunk ducts and supply and return air plenums is recommended to minimize vibration transmission.

NOTE: Connect supply and return air plenums to unit in a manner that will allow the top of the unit to be removed without removing plenums. Plenums **MUST** be individually sealed to unit casing with ducts terminating inside structure.

FILTERS

All return air **MUST** pass through a filter before entering the unit. An electronic air cleaner, optional filter racks, or other accessible filter arrangement **MUST** be installed in the return air ductwork. Minimum recommended filter areas are listed in **FIGURE 8** and are based on a velocity of 325 ft/min for disposable filters and 525 ft/min for high velocity filters (washable).

CAUTION

DO NOT OPERATE THE UNIT WITHOUT A FILTER.

9. START-UP PROCEDURES

WARNING

Fire and/or explosion hazard.

Do **NOT** attempt to light the pilot or burner with a match or flame of any kind.

Failure to follow this warning can result in property damage, personal injury, and/or death.

CHECK BEFORE STARTING

1. Check that the blower motor speed terminal block is running the correct heating and cooling speeds.
2. Check to see that clean, properly sized air filters are installed.
3. Replace all service access panels.

Reverse Rotation (Scroll Compressors Only)

Three phase scroll compressor equipped units **CAN** run in reverse if improperly wired. If the compressor makes an unusually loud noise, or if high and low side pressures are nearly identical, this indicates reverse rotation. To correct, reverse any two wires at line voltage connections **ONLY**. Do **NOT** re-wire any circuits inside the unit to attempt correction of reverse rotation.

Manifold Gas Pressure Adjustment

NOTE: Make adjustment to manifold pressure with burners operating.

WARNING

Fire or explosion hazard.

Turn **OFF** gas at shut off before connecting U-tube manometer.

Failure to properly seal duct can result in personal injury and/or death.

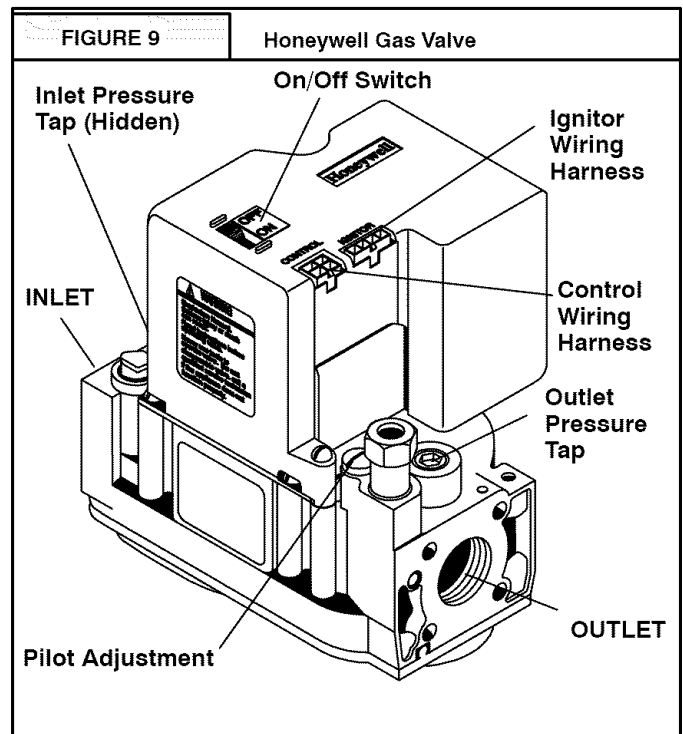

GAS PRESSURES

1. Do **NOT** allow gas supply pressure to fall below the listed minimums. Doing so will decrease input to furnace. Refer to **FIGURE 10** for gas supply pressures.
2. Gas input **MUST NOT** exceed rated input shown on rating plate.
3. Do **NOT** allow pressures to exceed the maximum limits as listed in **FIGURE 10**.

FIGURE 10	Gas Pressures	
	Natural Gas	LP Gas
Minimum Inlet	4.5" W.C. (1120 Pa)	11" W.C. (2740 Pa)
Recommended Inlet	7" W.C. (1740 Pa)	11" W.C. (2740 Pa)
Maximum Inlet	13" W.C. (3230 Pa)	13" W.C. (3230 Pa)
Manifold Pressure	3.5" W.C. (870 Pa)	10" W.C. (2490 Pa)

Manifold Pressures

Manifold pressures are covered in the startup procedure section. Refer to **Chapter 9 Start-Up Procedures**.

1. With gas **OFF**, Connect U-Tube manometer to tapped opening on gas valve. Use manometer with a 0 to 12 inches water column range.

FIGURE 11	Manifold Pressure Settings
Gas Type	Manifold Pressure
Natural	3.5 Inches Water Column (870 Pa)
Propane	10 Inches Water Column (2490 Pa)

2. Turn gas **ON** and remove adjustment screw cover on gas valve. Turn counterclockwise to decrease pressure and clockwise to increase.

NOTE: Adjustment screw cover **MUST** be placed on gas valve before reading manifold pressure and operating furnace.

WARNING

Fire and/or explosion hazard.

Do **NOT** adjust manifold pressure more than ± 0.3 inches water column to obtain rated input.

Failure to properly set input pressure can result in property damage, personal injury and/or death.

3. Set pressure to value shown in **FIGURE 11**, ± 0.07 kPa (0.3 inches) water column. Pressure is also listed on furnace rating plate. In **NO** case should final manifold pressure vary more than ± 0.07 kPa (0.3 inches) water column.

CIRCULATING AIR BLOWER

Check the unit's operation as outlined in the following instructions. If any unusual sparking, odors or unusual noises are encountered, shut off electric power immediately. Recheck for wiring errors, or obstructions in or near blower motors.

1. Set thermostat Heat-Cool selector to **OFF**.
2. Set thermostat fan switch to **AUTO**.
3. Turn electric power **ON**. Nothing should start running.
4. Turn manual gas valve **ON**.
5. Turn gas control valve **ON**.
6. Set thermostat fan switch to **ON**.
7. Reset thermostat fan switch to **AUTO**.

HEATING START-UP PROCEDURE

1. Adjust thermostat setting above room temperature and set thermostat selector to **HEAT**. The combustion air blower should come **ON**.
2. The ignitor should begin to glow and pilot flame should light. Refer to Lighting/Operating Instructions label located on Burner Access Panel of unit.

NOTE: On a call for heat the ignitor and pilot valve will remain energized until a flame is detected by the flame sensor. It may take several minutes to purge the air out of the gas lines at initial start-up of the unit.

3. Once the flame sensor detects that a flame is present, the hot surface ignitor will de-energize and the main burners will light from the pilot.
4. 30 seconds after the burners light, the circulating blower should begin to run.

WARNING

Fire and/or explosion hazard.

Do **NOT** attempt to light the pilot or burner with a match or flame of any kind.

Failure to follow this warning can result in property damage, personal injury, and/or death.

Temperature Rise Check

NOTE: Air temperature rise is the temperature difference between supply and return air. With a properly designed distribution system, the proper amount of temperature rise will normally be obtained when the unit is operating at rated input with the recommended blower speed.

1. The temperature rise must be within the specifications marked on the unit rating plate.

To check the temperature rise through the unit, place thermometers in the supply and return air ducts as close to the unit as possible.

Open **ALL** registers and duct dampers. Operate unit **AT LEAST** 15 minutes before taking readings.

If the correct amount of temperature rise is not obtained when operating on the recommended blower speed, it may be necessary to change the blower speed. A faster blower speed will decrease the temperature rise. A slower blower speed will increase the temperature rise.

NOTE: The blower speed **MUST** be set to give the correct air temperature rise through the furnace as marked on the rating plate. See **FIGURE 13** for more information.

2. After 15 minutes of operation check the limit control function by blocking the return air grille(s).

After several minutes the main burners and pilot should go **OFF**. The circulating air blower should continue to run.

Remove air restrictions. Pilot and main burners should relight after a cool down period of a few minutes.

3. Adjust the thermostat setting below room temperature. Pilot and main burners and combustion air blower should go **OFF**.

The circulating air blower should continue to run for 60, 100, 140 or 180 seconds. This time is adjustable. See **FIGURE 12** for more information.

4. Set thermostat Heat-Cool selector to **OFF**.

FAN CONTROL CHECK

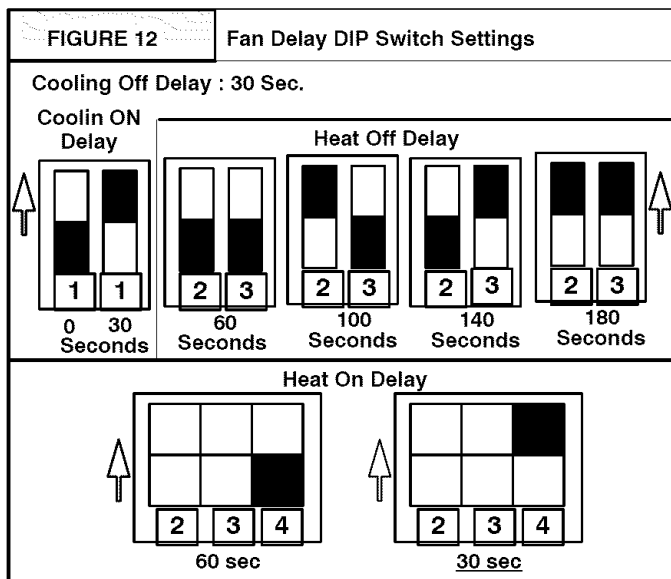

The Fan Control has adjustable settings for the circulating air blower to delay it "ON" and "OFF".

1. The "ON" delay is factory pre-set at 30 seconds. It can be adjusted to 60 seconds.
2. The "OFF" delay is factory preset at 140 seconds. It can be adjusted to 60, 100 and 150 seconds, respectively.

Refer to **FIGURE 12** for proper DIP switch settings.

3. Operate the furnace and ensure that the blower turns **ON** and **OFF** at the appropriate time to provide the desired comfort level.

SPEED TAPS

After determining necessary CFM and speed tap data, follow the steps below to change speeds.

1. Refer to **FIGURE 13** and locate the speed tap block on blower motor.
2. The yellow lead **MUST** always be connected to the speed tap block at the common quick connect terminal. The terminal is identified as **COM**. Also, this is the only lead which is $\frac{3}{16}$ " wide. All other quick connects are $\frac{1}{4}$ " wide.
3. If it has been determined that cooling and heating speeds are needed on the same speed tap, remove the red heating lead from the speed tap block and connect it to the insulated male terminal on the black cooling lead. Then place the insulated black female quick connect to the required speed tap.

CONTINUOUS FAN OPERATION

An optional terminal may be provided on the electronic fan control located in the electrical control box area for operation of the continuous fan option. This connection is intended for the low speed motor tap, and has a lower contact rating (8 amps) than the heat and cool taps. When the low speed blower lead is connected to this terminal, this will provide low speed blower operation whenever the other two speeds (**Heat** or **Cool**) are not energized.

Thoroughly check the system after modification to ensure the proper operation of the circulating air blower in all modes of operation.

Separate Speed Selections for Heat, Cool and Continuous Fan

Connect low speed lead from circulating motor to the "Cont" terminal at the electronic fan control. The appropriate motor leads should already be connected to the "Heat" and "Cool" terminals.

Note: See next section "*Heating or Cooling and Continuous Blower Speed the Same*" if low speed is required for heating to obtain desired temperature rise.

Heating or Cooling and Continuous Blower Speed the Same

If it is necessary to operate the heating or cooling speed and continuous blower speed using the same blower speed, connect a jumper between the "Heat" and "Cont" terminals on the Fan Timer Board.

Note: There should be only **ONE** motor lead going to the "Heat" and "Cont" terminals.

COOLING

1. Turn electric power **OFF**
2. Set thermostat Heat-Cool select to **COOL**.
3. Adjust thermostat setting to below room temperature.
4. Turn power **ON**, for approximately one minute, then **OFF**. During power application check the following:
 - a. Contactor - Contacts Closing
 - b. Compressor - **ON**
 - c. Condenser fan motor - **ON**
 - d. Circulating Air Blower - **ON** 0 or 30 second delay
5. Turn power **OFF**, check the following:
 - a. Contactor contacts opening.
 - b. Compressor - **OFF**
 - c. Condenser fan motor - **OFF**
 - d. Circulating blower - **OFF** after a 30 second delay.

FIGURE 13

Blower Motor Speed Taps (3-Speed and 4-Speed Motors)

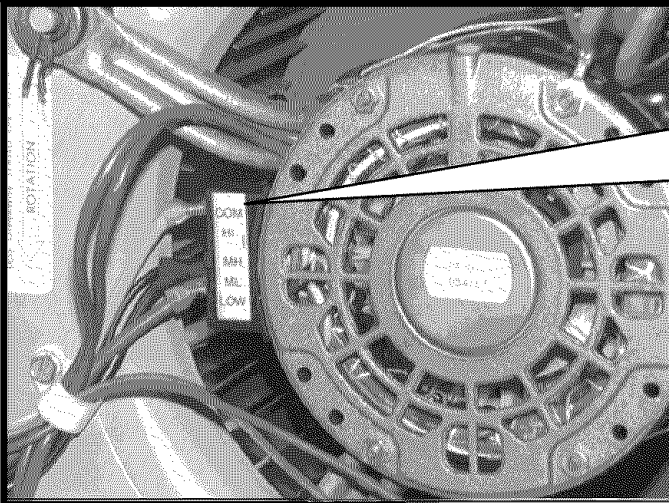

BE SURE TO CHECK BLOWER MOTOR SPEED DATA IN UNITS TECHNICAL INFORMATION LABEL ON THE UNIT

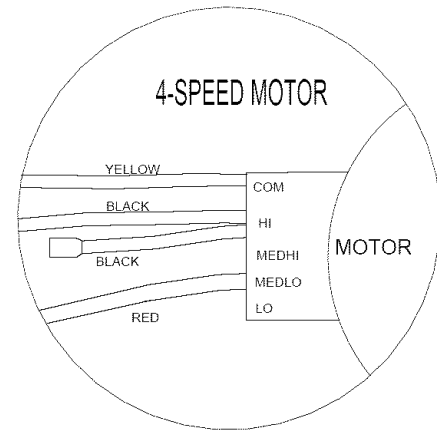
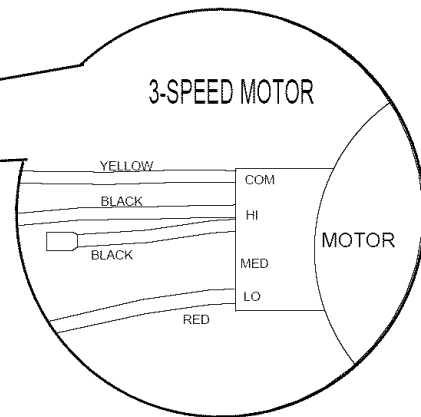

10. OPERATION

Once the thermostat is satisfied, the fan control will operate the blower for 30 additional seconds.

WARNING

Electrical shock hazard.

Turn off electric power supply at disconnect switch or service panel before removing any access or service panel from unit.

Failure to follow this warning can result in property damage, personal injury, and/or death.

11. MAINTENANCE

MONTHLY MAINTENANCE AND INSPECTION CHECKS

Air Filters

CAUTION

Do NOT operate without air filters.

Inspect filters at least monthly and replace or clean as required. Washable filters may be cleaned by soaking in mild detergent and rinsing with cold water. Replace filters with the arrows on the side pointing in the direction of air flow. Dirty filters are the most common cause of inadequate heating or cooling performance, and of compressor failures.

HEATING SEASON CHECKS (MONTHLY)

Pilot Flame

While the main burner is on, the flame should envelop the upper part of the flame sensor.

Main Burner Flame

Flames should be stable and solid blue, (dust may cause orange tips or they may have wisps of yellow, but they **MUST** not have solid yellow tips). They should extend directly into the heat exchanger tubes and the turbulators

COMBUSTION/INDOOR FAN CONTROL

All functions of the combustion and indoor blower are controlled by the fan control module.

On a call for heat:

The fan control energizes the combustion blower. Once the combustion air proving switch closes, the ignition sequence begins. The fan control will sense when the main operator of gas valve has been energized thereby firing the burners and starting the "delay on" timing sequence of the indoor blower.

NOTE: If the control senses that one of the safety limits has opened, the combustion and indoor fans will operate until the limit resets.

On a call for cooling:

The fan control starts the indoor blower at 0 or 30 seconds.

should glow orange (after about five minutes of operation). Main burner flame should be inspected monthly.

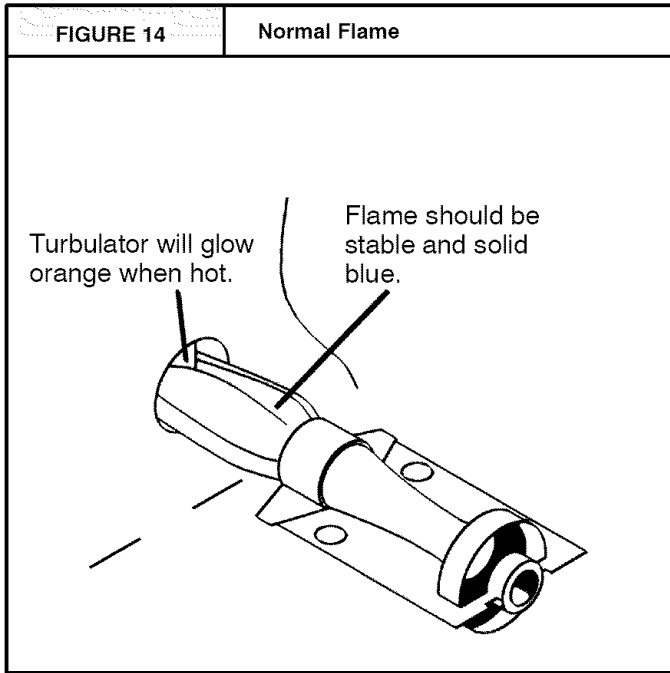

Using a light and mirror (as required) inspect the inside of the vent hood and the inlet air opening in the burner compartment. Look for soot and severe rust or corrosion and any obstructions due to leaves, spiderwebs, etc. Clean as required.

COOLING SEASON CHECKS (MONTHLY)

Condenser Coil

Keep the condenser inlet and outlet area clean and free of leaves, grass clippings or other debris. Grass should be kept short in front of the condenser inlet. Shrubbery **MUST** be trimmed back so it is no closer than 30 inches to unit.

Condensate Drain

Check for condensate drainage. Clean as required.

ANNUAL MAINTENANCE AND INSPECTION

WARNING
Electrical shock hazard.
Turn off electric power supply at disconnect switch or service panel before removing any access or service panel from unit.
Failure to follow this warning can result in property damage, personal injury, and/or death.

The annual inspection should include lubrication and cleaning as required to ensure efficient operation of the unit. To simplify access, remove all access panels and the top from the unit if possible .

Condenser Fan Motor

Oil the condenser fan motor after five years of operation and every five years thereafter, if applicable.

VENT ASSEMBLY

WARNING
Burn hazard.
Flue cover may be hot! Allow adequate time for flue cover to cool.
Failure to follow this warning can result in property damage or personal injury.

Use SAE 10W30 motor oil. To oil, remove the hole plugs from the motor end bells and add several drops (approximately 1/2 teaspoonful) of oil with a squeeze type, flexible tube oiler. Replace hole plugs after oiling. Do not over oil.

Clean the surrounding area and the condenser and evaporator coils. Use caution to avoid damage to coil fins.

BLOWER MOTOR ACCESS

Refer to **Figure 15** for a view of blower motor and compartment.

1. Remove the blower access panel
2. Remove the three screws securing the blower motor housing. If unit has a support bracket, remove the two screws securing the bracket.
3. Remove the two red wires attached to the limit switch and remove the limit switch.

Motor removal and replacement

This method is required to replace or repair blower wheel, blower housing, or any unreachable components behind blower assembly.

1. Remove all screws around rim of unit top, (except screws which are inaccessible because of proximity to structure).
2. Raise unit top at corner of unit closest to blower at least 2" and place a sturdy brace at least 2" thick between top and unit corner. See **FIGURE 15**. A 2X4 piece of wood is ideal for this.
3. Disconnect all wires from housing and slide housing out of unit. Reverse this process to reinstall.

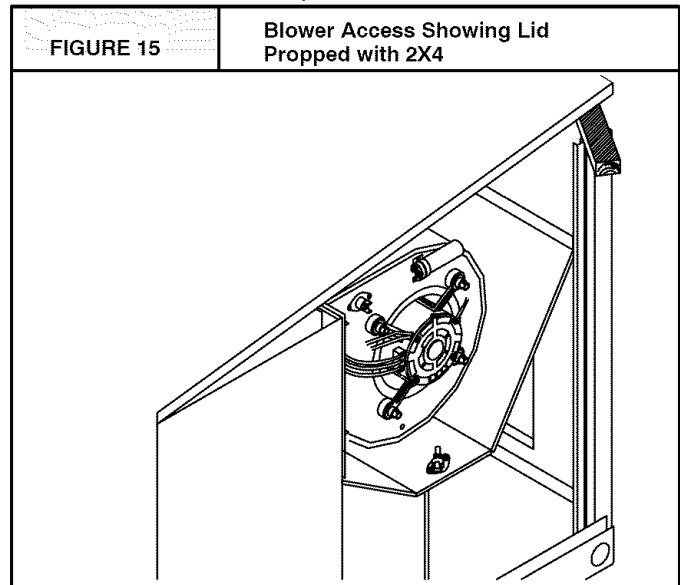

Circulating Air Blower

Visually inspect the blower wheel for accumulations of dirt or lint. Clean the compartment and the blower wheel. If accumulation is excessive on blower wheel, or does not easily remove, it will be necessary to remove the blower assembly.

Oil the blower motor, if applicable, by adding $\frac{1}{2}$ teaspoonful (1cc) of SAE 10W30 to each motor bearing. The blower motor should be oiled after five years of operation and every five years thereafter.

CAUTION

Do not use 3 in 1 oil, penetrating oil, WD40 or similar oils to oil motor bearings.

Burners / Heat Exchangers / Flue Gas Passages

To inspect the burners, heat exchanger and interior flue gas passages, use a light and small mirror on an extension handle.

Check the exterior of the heat exchanger and the interior flue gas passages for any evidence of deterioration due to corrosion, cracking or other causes. If signs of scaling or sooting exist, remove the burners and clean the heat exchanger, as required.

INSPECTION AND CLEANING OF BURNER ASSEMBLY/HEAT EXCHANGERS/FLUE GAS PASSAGES

For Qualified Service Technician Only

See **FIGURE 16** for identification of parts.

1. Disconnect electrical power to unit.
2. Turn **OFF** gas at manual shut off valve.
3. Remove burner access panel.
4. Remove the vent assembly flue pipe.
5. Disconnect gas pipe at union.
6. Disconnect wires from gas valve, note connections.
7. Remove screws that secure the flame shield and remove gas control valve, manifold and burners as an assembly.
8. Remove collector box, injector plate, and restrictor plate, including gaskets.
9. Hold the burner assembly vertically and lightly tap it against a wood block. Clean also with a stiff brush. Severe cases of lint clogging may require washing the burners in hot water.
10. Clean flue gas passages by using small brushes and a vacuum cleaner. It may be necessary to fabricate handle extensions for the brushes to reach the areas that require cleaning. Reinspect after cleaning and replace the heat exchanger if defective.
11. Reinstall parts and gaskets in reverse order. On spark to pilot models check the spark gap. $\frac{1}{8}$ inch is required between the igniter and pilot hood.
12. Turn gas on and check for leaks.
13. Install all access panels, turn power on and check for normal operation.

FIGURE 16

Access to Burners

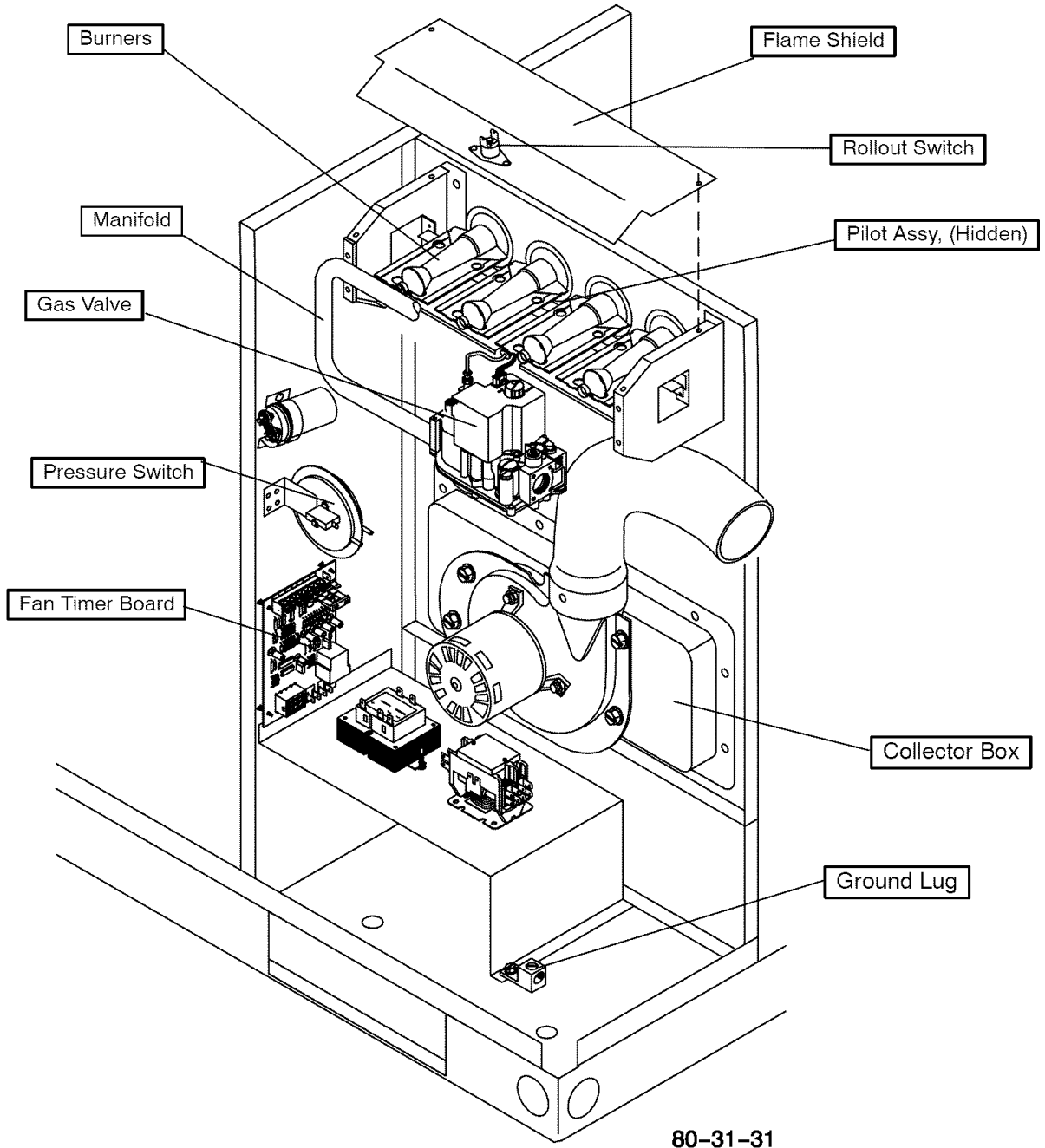

Pilot Assembly

RIGGING INSTRUCTIONS

1096286



WARNING

FAILURE TO FOLLOW THESE INSTRUCTIONS CAN RESULT IN PROPERTY DAMAGE, BODILY INJURY OR DEATH.

- ALL PANELS MUST BE IN PLACE WHEN RIGGING AND LIFTING.
- HOOK RIGGING SHACKLES THROUGH HOLES IN BASE RAIL, AS SHOWN IN DETAIL-A.
- USE SPREADER BARS, WHEN RIGGING, TO PREVENT UNIT DAMAGE.
- BE SURE RIGGING AND SHACKLES ARE SUFFICIENT TO HANDLE WEIGHT LISTED BELOW.

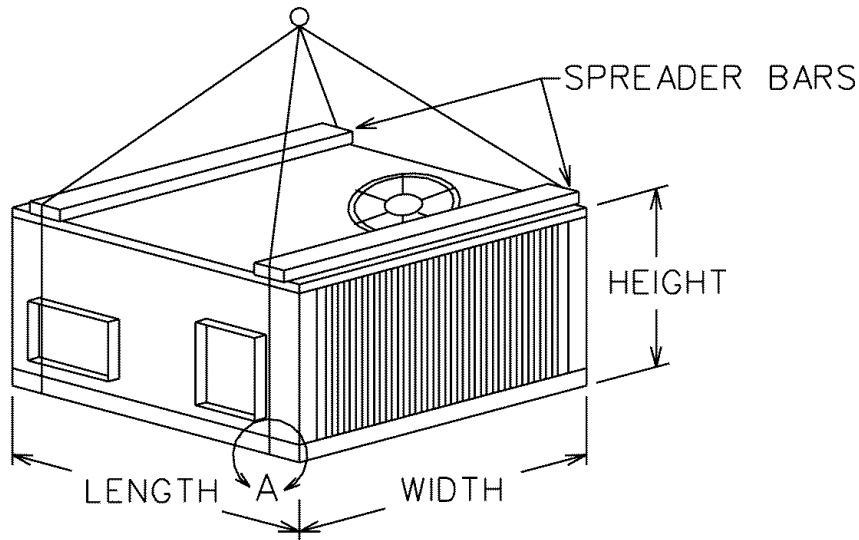

DETAIL - A

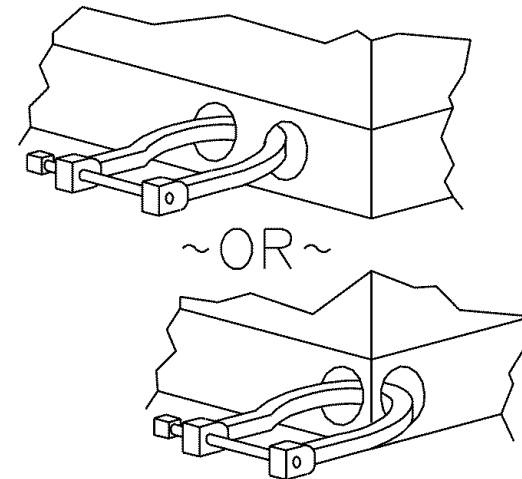

CABINET	MAX. LENGTH		MAX. WIDTH		MAX. HEIGHT		MAX. WEIGHT	
	IN	MM	IN	MM	IN	MM	LB	KG
SMALL	52.00	1219	48.00	1219	38.00	965	500	227
LARGE	73.00	1854	48.00	1219	38.00	965	900	409

INTERNATIONAL COMFORT PRODUCTS
LIMITED WARRANTY CERTIFICATE
For Cooling & Heating Products

SAVE THIS CERTIFICATE. It gives you specific legal rights, and you may also have other rights which may vary from state to state and province to province.

If your unit needs servicing, contact a qualified dealer or qualified service agency of your choice. When requesting service, please have the model and serial number from each unit in your heating and/or cooling system readily available. If your dealer needs assistance, the distributor is available to provide support and we, in turn, support its efforts.

Fill in the installation date and model and serial numbers of the unit in the space provided below and retain this Limited Warranty for your files.

GENERAL TERMS

Subject to the conditions and limitations stated herein, during the term of this Limited Warranty, we will provide a replacement for any functional component part (as defined below) of your unit that fails due to defect in materials or workmanship. The term of this Limited Warranty is five years from installation on Residential Products and one year from installation on Commercial Products or applications. Except as otherwise stated in the "Additional Terms" section, this Limited Warranty covers only the original purchaser and subsequent transferees, and only while the unit remains at the site of the original installation (except for mobile home installations), and only if the unit is installed inside the continental United States, Puerto Rico, Alaska, Hawaii or Canada. In addition, the Limited Warranty applies only if the unit is installed and operated in accordance with the printed instructions accompanying the unit, and in compliance with all applicable installation and building codes and good trade practices. As used in this Limited Warranty, "installation" means the original installation of the unit.

THERE ARE EXCEPTIONS to this Limited Warranty as described on the reverse side of this page. All replacement parts will be warranted for the unused portion of the warranty coverage period on the unit. The part to be replaced must be returned by the dealer to a distributor that sells products for International Comfort Products, in exchange for the replacement part. In lieu of providing a replacement part, we may, at our sole option, refund to you an amount equal to the distributor's component purchase price from us, or provide to you a credit equal to that amount to be applied toward the purchase of any new unit that we distribute. If a credit for a new unit is given in lieu of a replacement part, the rating plate from the unit being replaced must be submitted on a warranty claim, and your dealer must make the unit being replaced available to our distributor for disposition. As a condition to warranty coverage, the unit must receive yearly maintenance, as described in the owner's manual, by a dealer. Satisfactory proof of yearly service by a dealer may be required.

"Functional component parts" include only the following: blower motor, unit-mounted sensors & timers, condenser motor, evaporator coil, condenser coil, condenser fan, capacitor, transformer, single-phase strip heat elements, expansion device, reversing valve, solenoid valve, service valve, electronic and electro-mechanical control board, ignitor, ignition module, draft inducer assembly, burner pilot, gas valve, limit control, pressure switch, relays and contactors, blower wheel, interlock switch, crosslighter, pilot shield, gas & oil burners, oil pump assembly, accumulators and factory installed driers and strainers.

This Limited Warranty **DOES NOT COVER** any labor, material, refractory chambers, oil nozzles, refrigerant, refrigerant inspection and refrigerant reclaiming, freight and/or handling charges associated with any repair or replacement and such charges will be your responsibility.

To establish the installation date for any purpose under this Limited Warranty, you must retain the original records that can establish the installation date of your unit. If you do not provide such documents the start date of the term of this Limited Warranty will be based upon the date of unit manufacture, plus thirty (30) days. In establishing that the required yearly service has occurred, you must furnish proof of yearly service by a qualified service agency.

This Limited Warranty does not cover: (a) failure or damages caused by accident, abuse, negligence, misuse, riot, fire, flood, or Acts of God (b) damages caused by operating the unit where there is a corrosive atmosphere containing chlorine, fluorine, or any other damaging chemicals (other than those found in a normal residential environment) (c) damages caused by an unauthorized alteration or repair of the unit affecting its stability or performance (d) damages caused by improper matching or application of the unit or the unit's components (e) damages caused by failing to provide proper maintenance and service to the unit in accordance with this Limited Warranty Certificate and the printed instructions originally provided with the unit (f) any expenses incurred for erecting, disconnecting, or dismantling the unit (g) parts or supplies used in connection with service or maintenance, such as refrigerant, refractory chambers, oil nozzles, filters, or belts (h) damage, repairs, inoperation or inefficiency resulting from faulty installation or application (i) electricity or fuel costs or any increase in electricity or fuel cost whatsoever including additional or unusual use of supplemental electric heat (j) units which have not had the required yearly maintenance described elsewhere in this limited warranty.

In no event shall we be liable for any incidental, consequential, or special damages or expenses in connection with any use or failure of this unit.

WE HAVE NOT MADE, DO NOT MAKE, AND HEREBY DISCLAIM ANY IMPLIED CONDITION OR IMPLIED WARRANTY OF FITNESS FOR A PARTICULAR USE OR PURPOSE, AND ANY IMPLIED CONDITION OR IMPLIED WARRANTY OF MERCHANTABILITY, TO THE FULLEST EXTENT ALLOWED BY LAW. WE MAKE NO EXPRESS OR IMPLIED WARRANTIES EXCEPT AS STATED IN THIS LIMITED WARRANTY CERTIFICATE.

No one is authorized to change this Limited Warranty or to create for us any other obligation or liability in connection with this unit. Any implied warranties that are not disclaimable shall last only for the term of the express warranty contained herein. Some states and provinces do not allow the exclusion or limitation of incidental or consequential damages or do not allow limitations on how long an implied warranty or condition lasts, so the above limitations or exclusions may not apply to you. The provisions of this Limited Warranty are in addition to and not a modification of or subtraction from any statutory warranties and other rights and remedies provided by law.

Please refer to reverse side of this page for additional terms.

Model No. _____

Serial No. _____ Date Installed _____

USA: International Comfort Products, LLC • 650 Heil-Quaker Avenue • P.O. Box 128 • Lewisburg, Tennessee 37091 • (931-270-4100)
CANADA: International Comfort Products division of UTC Canada Corporation • 6060 Burnside Court, Unit 1, Mississauga, Ontario L5T 2T5 (905-795-8113).
Manufacturers of Airquest, Arcoaire, Clare, Comfortmaker, Dettson, Heil, Keeprite, Lincoln, Tempstar and other quality brand name private label products.

Part No. 401 06 1010 24 (Orig. 11/xx/2003)

ADDITIONAL TERMS FOR RESIDENTIAL APPLICATIONS ONLY

The Additional Terms for the components listed below are in addition to, and subject to, the General Terms on the reverse side of this page. Warranty coverage is limited to parts that fail due to defect in materials or workmanship during the specified term.

CENTRAL GAS & OIL FURNACE HEAT EXCHANGERS*

Gas Model Series: C9MPV, H9MPV, T9MPV, C9MPT, H9MPT, T9MPT, C9MPD, H9MPD, T9MP: Limited Lifetime Warranty on heat exchangers. If a heat exchanger on one of these furnaces fails due to defect in the part, we will provide a replacement part or, at our option, credit toward the purchase of a new furnace manufactured by us. This additional Limited Warranty runs only to the original purchaser, and lasts only for as long as the original purchaser lives in the home where the furnace is initially installed.** It is not transferable to any subsequent owner. If the furnace was not installed in the home owned by the original purchaser, if the original purchaser sells the home to a subsequent owner, or if proof of original purchase cannot be provided, then the limited warranty is only for 20 years from the date of original installation.

Gas Model Series: T8MPV, H8MPV, C8MPV, T8MPT, H8MPT, C8MPT: A replacement heat exchanger will be provided for any heat exchanger that fails in one of these furnaces due to defect for 25 years from the original date of installation.

Gas Model Series: T8MPN, H8MPN, C8MPN, T8MPL, H8MPL, C8MPL, T8DNL, H8DNL, C8DNL, N8MPN, N8MPL, N9MP1, N9MP2: A replacement heat exchanger will be provided for any heat exchanger that fails in one of these furnaces due to defect for 20 years from original date of installation.

Oil Model Series: OLR(105, 160, 182), OCF, OLF, OUF, NOLF, NOUF, OLB, OHB, ODH, FLO, MBO, LBO, NOME: Limited Lifetime Warranty on heat exchangers. If a heat exchanger on one of these furnaces fails due to defect in the part, we will provide a replacement part or, at our option, credit toward the purchase of a new furnace manufactured by us. This additional Limited Warranty runs only to the original purchaser, and lasts only for as long as the original purchaser lives in the home where the furnace is initially installed.** It is not transferable to any subsequent owner. If the furnace was not installed in the home of the original purchaser, if the original purchaser sells the home to a subsequent owner, or if proof of original purchase cannot be provided, then the limited warranty is only for 20 years from the date of original installation.

Oil Fired Floor Furnace: NFO: A replacement heat exchanger will be provided for any heat exchanger that fails due to defect for 10 years from installation with the following limitation: during the sixth through tenth year, any credit toward your purchase of a component or toward the purchase of any new unit will be in an amount equal to the distributor's purchase price reduced by 20 percent for each year after the fifth year.

ADDITIONAL TERMS FOR OIL FURNACE APPLICATIONS ONLY

- 1) OIL BURNERS - A replacement for 5 years from date of original installation for Oil Burner Parts.
- 2) OPTIONAL ACCESSORIES AND FUNCTIONAL PARTS: A replacement for 5 years from date of original installation. (Refractory and oil nozzles not included)

GAS/ELECTRIC PACKAGED UNITS HEAT EXCHANGERS

Model series: PGAD, PGAA, PGMD, PGME, PGF, GPFM, PGC, GPCM: A replacement for 10 years from original date of installation.

COMPRESSORS:*

1) **Premium Model Units: HAC0, HAC2, HAC4, CAC0, CAC2, CAC4, KAC0, TCA0, TCA2, TCA4, HHP0, HHP2, HHP4, CHP0, CHP2, CHP4, TCH0, TCH2, TCH4, HXA2, TXA2, CXA2, HXA4, TXA4, CXA4, PGME, PYMC, PHAD, PGAD, PA95, PAPC, PAK, APK:** To the original purchaser a replacement for 10 years from original date of installation, only if the unit is installed with factory matched coils, except air conditioner condensing units with a nominal SEER of 10 may be matched with evaporator coils of the same nominal tonnage regardless of manufacturer and in accordance to factory recommendations. This limited 10-year warranty is not transferable to any subsequent owner. HOWEVER, if the unit was not installed in the home owned by the original purchaser, if the purchaser sells the home to a subsequent owner, or if proof of original purchase cannot be provided, then the limited warranty is only for 5 years from the original date of installation.**

2) **All Other Models: Air Conditioners, Heat Pumps, & Combination Gas/Electric Units: NAC0, NAC2, NHP0, NHP2, AO, A2, HO, H2, PGF, PGC, GPFM, GPCM, PAF, APFM, PHF, HPFM, PGAA, PGMD, PA55, PH55, PAPA, PYPA, PGS, GPSM:** A replacement for 5 years from date of original installation, only if: (a) air conditioner condensing units with SEER rating in the range of 10 to 11 SEER are matched with evaporator coils of the same nominal tonnage regardless of manufacturer and in accordance to factory recommendations, or (b) heat pump condensing units are used with factory matched coils, unless written approval to do otherwise is obtained from manufacturer.

ADDITIONAL TERMS FOR COMMERCIAL PRODUCT OR APPLICATIONS ONLY

For purposes of this warranty a commercial product or application is one in which: the product has over 5 tons nominal cooling capacity, or is designed for operation with 3 phase electrical power, or is installed in a commercial establishment such as a beauty or hair salon, hospital, school, restaurant, church, hotel etc..

3-Phase Models: PGF, GPFM, GPF, PGAD, PGME, PGB, PGMG, PGMF, PGS, GPSM, PGE, APE, PAE, PAB, PAMD, PAS, PAF, APFM, APF, PHB, PHE, PYMD, HPB, PHS, CAC, ACC, CAE, ACE, CHC, HCC, CHE, HCE, CHB, YA:

The additional Terms of the components listed below are in addition to and subject to the General Terms on the reverse side of this page.

- 1) GAS FIRED HEAT EXCHANGERS (ALL MODELS, except PGS, GPSM 3 to 5 Ton):* A replacement for 10 years from date of original installation.
 - a) NOTE: PGS, GPSM 3 to 5 Ton Models:* A replacement for 15 years from date of original installation.
- 2) COMPRESSORS (ALL MODELS):* A replacement for 5 years from date of original installation.
- 3) OPTIONAL ACCESSORIES AND FUNCTIONAL COMPONENT PARTS (ALL MODELS):* A replacement for 1 year from date of original installation.
- 4) COMMERCIAL OIL MODELS: OLR210, OLR350, OTF210, AMT3, AMT4, AMP3: Ten(10) Year Limited Warranty on heat exchangers.

*To receive advantage of your limited warranty, you must provide proof of yearly service by a qualified service agency.

**To receive advantage of your warranty, you must retain the original records that can establish the installation date and proof of purchase of the unit.

MINI SPLITS:

Summary - Mini Splits Warranted for one (1) year on all replacement parts.

Additional terms for Mini Splits:

The additional Terms of the components listed below are in addition to, and subject to, the General Terms on the reverse side of this page.

1) **Compressors (All Models):** A replacement compressor will be provided for all compressors that fail due to defect for 5 years from date of original installation.

2) **Optional Accessories and Functional Components Parts (All Models):**

A replacement part will be provided for all parts that fail due to defect for one (1) year from date of original installation.

Failure to maintain the equipment through annual maintenance by a qualified service agency shall void the warranty. Proof of service will be required with all warranty claims. Proof of purchase and installation date must be submitted with all claims.