

Installation Instructions

SPLIT SYSTEM Premium Line AC & HP CONDENSERS

Save This Manual for Future Reference

Installation/ Startup Information

These instructions must be read and understood completely before attempting installation.

WARNING

Installation or repairs made by unqualified persons can result in hazards to you and others. Installation **MUST** conform with local building codes or, in the absence of local codes, with the National Electrical Code NFPA 70/ANSI C1-1999 or current edition and Canadian Electrical Code Part 1 CSA C.22.1.

The information contained in this manual is intended for use by a qualified service technician familiar with safety procedures and equipped with the proper tools and test instruments.

Failure to carefully read and follow all instructions in this manual can result in equipment malfunction, property damage, personal injury and/or death.

After uncrating unit, inspect thoroughly for hidden damage. If damage is found, notify the transportation company immediately and file a concealed damage claim.

CAUTION

Improper installation, adjustment, alteration, service or maintenance can void the warranty.

The weight of the condensing unit requires caution and proper handling procedures when lifting or moving to avoid personal injury. Use care to avoid contact with sharp or pointed edges.

Safety Precautions

1. Always wear safety eye wear and work gloves when installing equipment.
2. Never assume electrical power is disconnected. Check with meter and disconnect.
3. Keep hands out of fan areas when power is connected to equipment.
4. R-22 causes frost-bite burns.
5. R-22 is toxic when burned.

NOTE TO INSTALLING DEALER: The Owners Instructions and Warranty are to be given to the owner or prominently displayed near the indoor Furnace/Air Handler Unit.

Figure 1 Dimensions

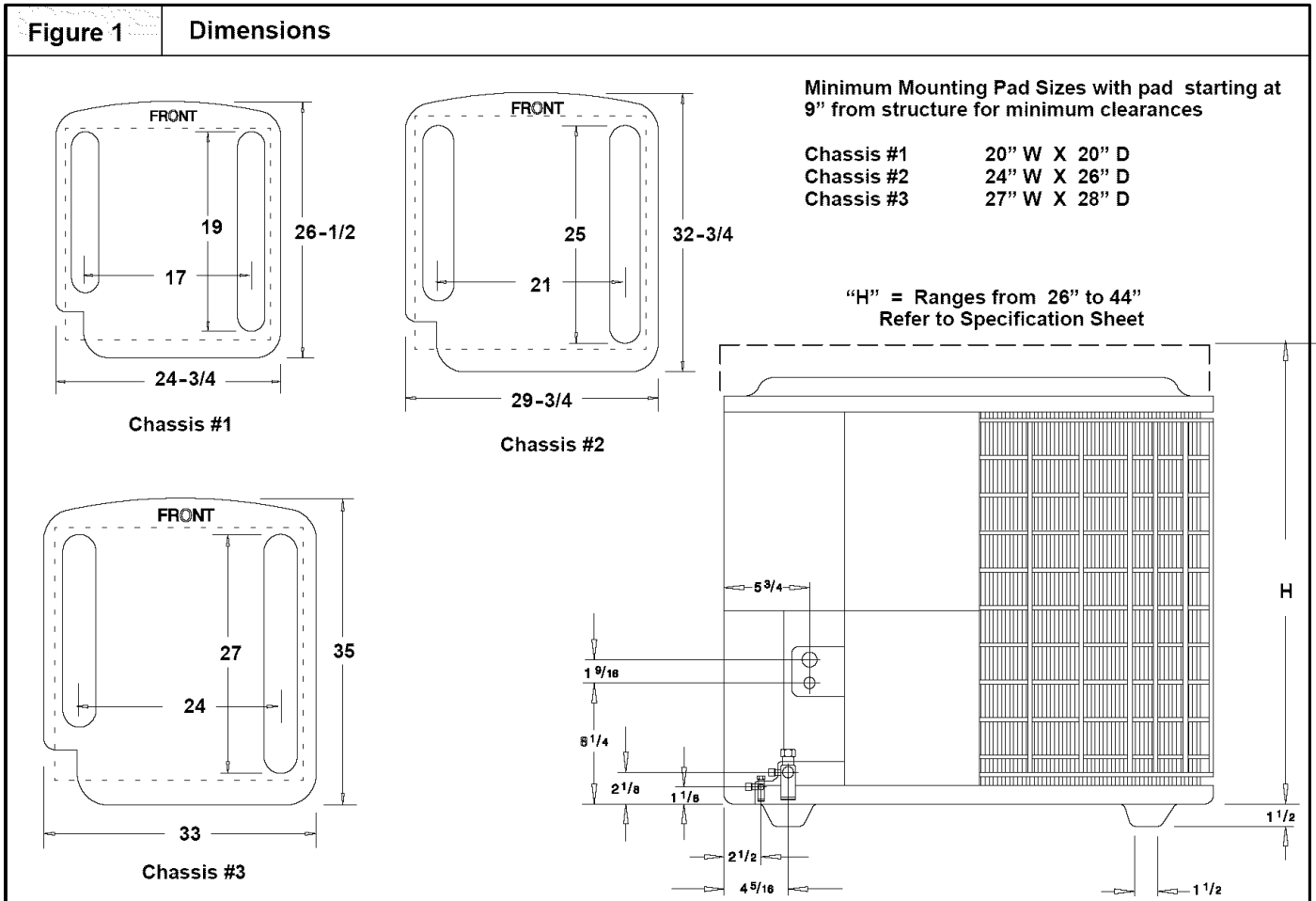

Locating The Outdoor Unit:

Check local codes covering zoning, noise, platforms.

If practical, avoid locating next to fresh air intakes, vent or bedroom windows. Noise may carry into the openings and disturb people inside.

Placement of the unit should be in a well drained area or unit must be supported high enough so runoff will not enter the unit.

Do not locate where heat, lint or exhaust fumes will be discharged on unit (as from dryer vents).

Roof top installations are acceptable providing the roof will support the unit and provisions are made for water drainage and the noise or vibration through the structure.

Do not install the unit in a recessed or confined area where recirculation of discharge air may occur.

Heat Pumps Only: The top surface of platform must be above average winter snow levels to prevent coil blockage.

Clearances:

Nominal operating clearances, where practical, are 48 inches (120 cm) above unit for discharge air and 18 inches (40cm) around coil for intake air on three sides. Clearance on one side (normally between unit and structure) may be reduced to 6 inches (15cm). Nominal clearances are based from a solid parallel object, wall, roof overhang, etc.

Do Not install under roof overhangs without guttering. A minimum vertical clearance of 48" is required to overhang.

The clearance may be reduced from a single object with a small surface area, such as the end of a wall, outside corner of a wall, fence section or a post, etc. As a general rule the width of the object should equal the minimum clearance from the unit. For example, a 4 inch (10cm) fence post could be 4 inches (10cm) from the unit.

Inside corner locations on single story structures require evaluation. Large overhanging soffits may cause air recirculation in a corner area even though recommended clearances are maintained. As a guide locate the unit far enough out so that half of the discharge grille is out from under the soffit.

Two or more units may be spaced with 18 inches (45cm) between units.

A service clearance of 24 inches (60cm) is desirable from control box end or side. Control box and corner panel below it can be loosened and moved out to the side to facilitate servicing. Internal components can be accessed through control box corner or top only.

Unit Support:

The unit must be level, and supported above grade by beams, platform or a pad. Platform or pad can be of open or solid construction but should be of permanent materials such as concrete, bricks, blocks, steel or pressure treated timbers approved for ground contact. Refer to Unit Clearances to help determine size of supports etc. Soil conditions should be considered so the platform or pad does not shift or settle excessively and leave the unit only partially supported.

CAUTION

Inadequate support could cause excessive vibration and noise or binding and stress on refrigerant lines resulting in equipment failure.

To minimize vibration or noise transmission, it is recommended that supports not be in contact with the building structure. However, slabs on grade constructions with an extended pad are normally acceptable.

A. Ground Level Installation:

If beams or an open platform are used for support it is recommended that the soil be treated or area be graveled to retard the growth of grasses and weeds.

B. Roof Top Installation:

This type of installation is not recommended on wood frame structures where low noise levels are required.

Supporting structure or platform for the unit must be level. If installation is on a flat roof the unit should be 4 inches (10cm.) above roof level. Four by four posts placed over a load bearing wall make a suitable mounting platform.

If possible, place the unit over one or more load bearing walls. If there are several units, mount them on platforms that are self-supporting and span load bearing walls. These suggestions are to minimize noise and vibration transmission through the structure. If the structure is a home or apartment, avoid (if practical) locating the unit over bedrooms or study.

NOTE: When condensing unit is to be installed on a bonded guaranteed roof, a release must be obtained from the building owner to free the installer from all liabilities.

Figure 2

Clearances

Recommended Clearances

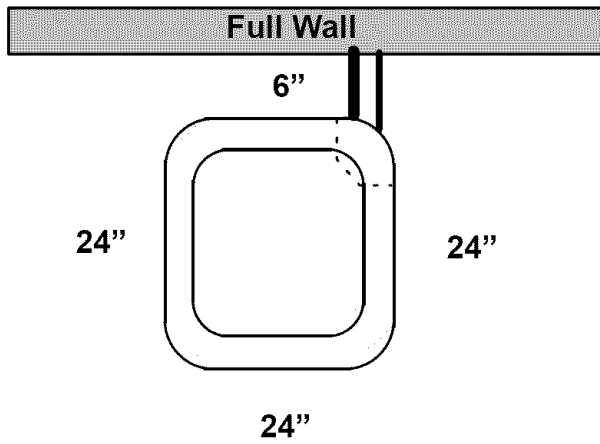

Minimum Clearances

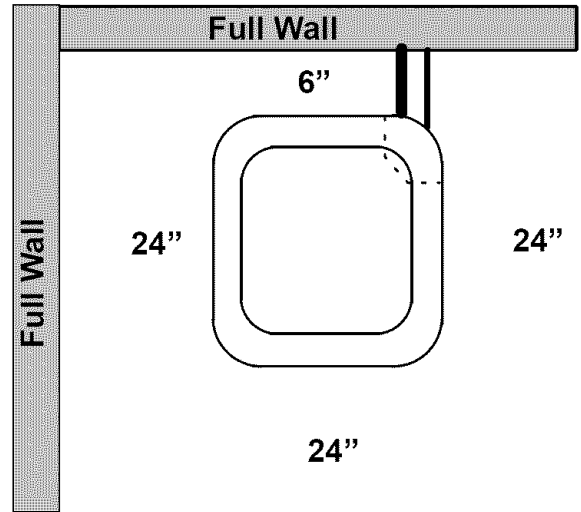

Minimum Clearances

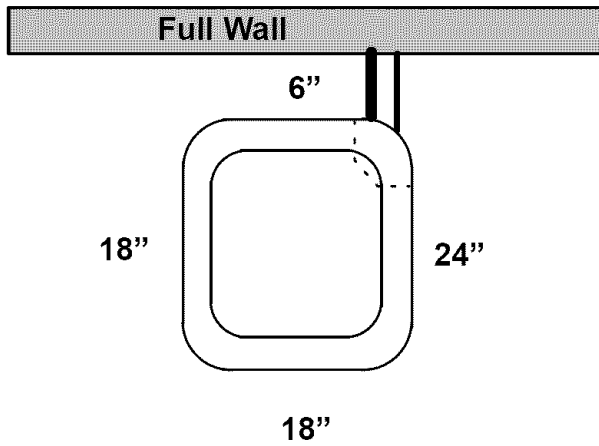

Minimum Clearances

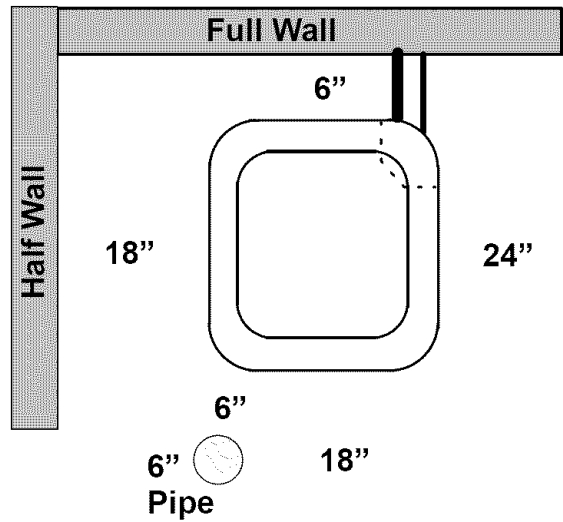

Minimum Clearances

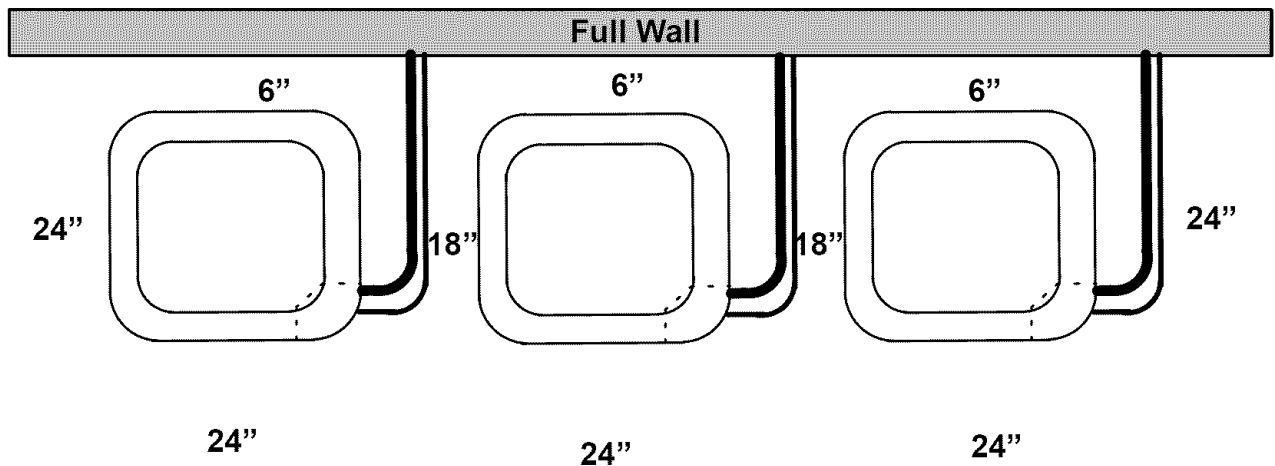

Installing Refrigerant Lines

Component Matches

Check to see that you have the proper system components. **APPROVED MATCHED SYSTEM COMPONENTS MUST BE USED.** Refer to the Sales Specification Sheet or Split System Summary for match data and orifice sizes.

The outdoor units are shipped with a refrigerant charge to match the indoor unit and 25 ft. (7.5m) of refrigerant line. If shorter or longer lines are used, the charge will have to be adjusted.

OUR STANDARD RECOMMENDED REFRIGERANT LINE LENGTH IS 75 ft. WITH A MAXIMUM VERTICAL SEPARATION OF 50 ft. BETWEEN THE OUTDOOR AND INDOOR UNITS WITH 3 TRAPS, 2 TRAPS FOR 40 FOOT RISE. LONGER REFRIGERANT LINES CAN BE INSTALLED BY USING THE EXTENDED LENGTH REFRIGERANT PIPING MANUAL #42106111400 WITH PRIOR APPROVAL FROM ICP TECHNICAL SERVICE DEPARTMENT.

Restrictor Orifice

Some indoor matches use a restrictor orifice in the fitting at the indoor coil. Some matches may require a different orifice for proper system performance and it must be changed before the refrigerant lines are connected.

Changing the Restrictor Orifice

The restrictor orifice is located in a fitting in the liquid line. The fitting is actually the distributor end of the cap tube assembly.

1. Remove the liquid line fitting and replace restrictor orifice. **(STANDARD RIGHT HAND THREAD)**
2. Make sure the restrictor is installed with the rounded end toward the feeder tubes. **See Figure 3.**

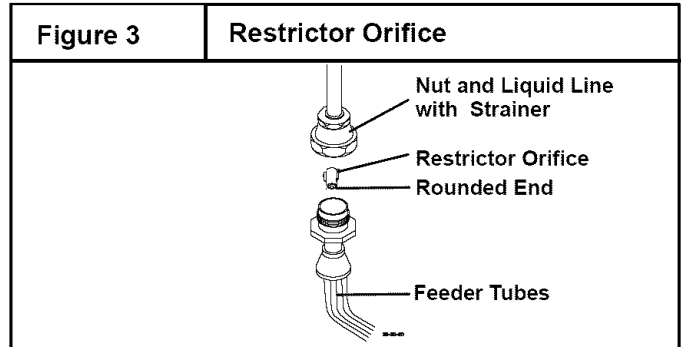

Refrigeration Line Sets

If it is necessary to add tubing in the field, use dehydrated or dry sealed deoxidized copper refrigeration tube. **DO NOT** use copper water pipe.

It is important that no tubing is cut or seals broken until you are ready to actually make connections to the evaporator and to the condenser section.

Do not remove rubber plugs or copper caps from the tube ends until ready to make connections at evaporator and condenser.

PLEASE! UNDER NO CIRCUMSTANCES LEAVE THE LINES OPEN TO THE ATMOSPHERE FOR ANY PERIOD OF TIME.

Be extra careful with sharp bends. This tubing can "kink" very easily, and if this occurs, the entire tube length will have to be replaced. Extra care at this time will eliminate future service problems.

Suspension And Installation Of Refrigeration Lines

DO NOT fasten liquid or suction lines in direct contact with the floor or ceiling joist. Use an insulated or suspension type of hanger. Keep both lines separate, and insulate the suction line. Both lines should be insulated in extremely long runs in an attic or underground in a raceway, 50' or more.

Do not let refrigerant lines come in direct contact with foundation. When running refrigerant lines through the foundation or wall, the openings should be made large enough to allow for a sound absorbing material to be placed or installed between the tubing and the foundation. This will prevent noise transmission between the tubing and the wall section (foundation) or the building.

Installation Instructions For Condensing Units That Are Higher Than Evaporator

It is recommended that vertical suction risers not be upsized. Proper oil return to the compressor should be maintained with suction gas velocity. If velocities drop below 1500 fpm (feet per minute), oil return will be decreased. An oil trap should be installed every 20' of vertical suction line riser (condenser above evaporator.) Refer to line sizing charts.

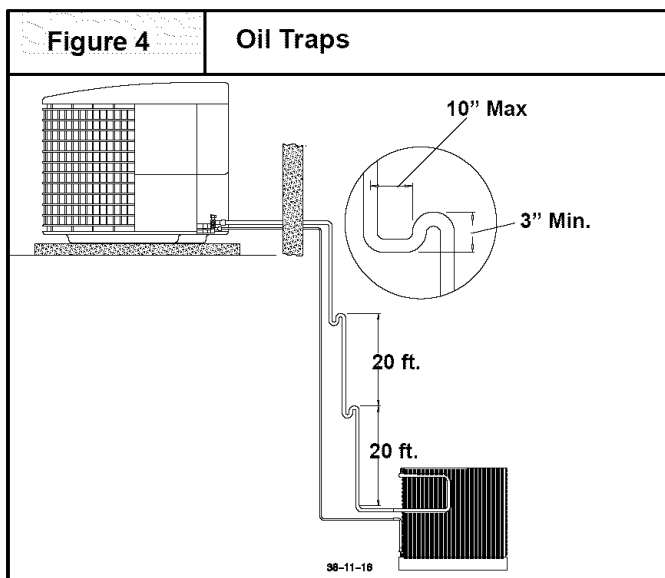

Line Valves

The outdoor condensing unit is supplied with straight sweat brass service valves with copper stubs.

All line valves are positioned to seal the refrigerant in the condensing unit with gauge ports open to connecting lines when the Schraeder valve is depressed. Gauge ports have Schraeder installed and require use of charging hoses with depressors.

Brazing Connections

WARNING

Fire Hazard

Refrigerant and oil mixture under pressure could ignite as it escapes and contacts brazing torch resulting in Fire. Make sure the refrigerant charge is properly removed from both the high and low sides of the system before brazing any component or lines.

FAILURE TO DO SO COULD RESULT IN BODILY INJURY OR DEATH.

Before making braze connections, be sure all joints are clean. Before heat is applied for brazing, nitrogen should be flowing through the tubing to prevent oxidation and scale formation on the inside of the tubing.

Liquid & Suction Lines

Fully annealed refrigeration lines should be used when installing the system.

The following is the recommended method for making braze connections at the refrigerant line connections:

1. Clean refrigerant tube end with emery cloth or steel brush.
2. Use a suitable brazing alloy for copper to copper joints.
3. Insert tubing into swage fitting connection.
4. Apply heat absorbing paste or heat sink product to prevent damage to the service valve.

CAUTION

Do not heat valve body above 250 degrees F.

5. Braze joint.
6. Quench the joint and tubing with water using a wet rag. Leave rag on fitting body and re-wet with water to help cool area.

Evacuating, And Charging Instructions

NOTE

Intentional release of CFC or HCFC Refrigerant to the Atmosphere violates Federal Law. It may also violate State and Local Codes. Check all Federal, State and Local Codes before proceeding.

These instructions are intended for use with condensing units that are precharged at the factory with adequate refrigerant to handle 25 feet.

NOTE: Do not use any portion of the charge for purging or leak testing. It is mandatory that a thorough evacuation of the refrigerant in the piping and evaporator be performed.

The liquid line and suction line service valves have been closed after final testing at the factory. **Do not disturb these valves until the lines have been leak checked and evacuated or the charge in the unit may be lost.**

Recommended Method Of Evacuating A System

1. Connect the vacuum pump to the suction and liquid line gauge ports.
2. If the evacuation is being performed on a new system installation, the valves should be kept in the "front seated" (closed) position. This will allow the mechanic to evacuate the refrigeration lines and the indoor coil, without disturbing the factory charge in the outdoor unit.
3. Follow the vacuum pump manufacturer's instructions. Allow the pump to operate until the system has been evacuated down to 300 microns. Allow the pump to continue running for an additional 15 minutes. Turn off the pump and leave the connections secured to the two service valves. After 5 minutes, if the system fails to hold 500 microns or less, check all connections for tight fit and repeat the evacuation procedure.

4. Isolate the vacuum pump from the system by closing the shutoff valves on the gauge bar. Disconnect the vacuum pump.

Valve Actuation: Service Valves

Remove the service valve cap, if there is a male valve stem see instructions for Ball Valves. For the standard service valve there are two variations, but both have internal stems. The first style uses an internal snap ring to retain the valve stem and the second has a rolled top and also has finer threads on the valve cap. **NOTE: You may encounter more than one type of valve on a unit.**

For service valves fully insert a hex wrench into the stem. A back-up wrench is required on the valve body to open the valve stem. Backout counterclockwise until the valve stem stops or just touches the retaining ring. **NOTE: THIS IS NOT A BACKSEATING VALVE.** For valves with retainer rings care must be taken to prevent dislodging them when opening valve.

Electrical Wiring

WARNING

Electrical Shock Hazard.

Shut off electric power at fuse box or service panel before making any electrical connections.

Failure to shut off electric power can result in, property damage, personal injury and/or death.

The supply voltage should be 208–230 volts (196 volt minimum to 253 volts maximum) 60Hz single phase.

APPROVED FOR USE WITH COPPER CONDUCTORS ONLY. DO NOT USE ALUMINUM WIRE.

REFER TO UNIT RATING PLATE FOR CIRCUIT PROTECTION.

Grounding

The service valve cap is a primary seal for the valve and must be properly tightened to prevent leaks. Make sure cap is clean and apply refrigerant oil to threads and sealing surface of cap.

For valves with retaining rings: Replace service valve cap and torque to; 8–11 ft. lbs. on 1/4" and 3/8" valves, 12–16 ft. lbs. on 5/8" and 3/4", 15–21 ft. lbs on 7/8" valves. If torque wrench is not available, tighten cap finger tight and then tighten one (1) additional wrench flat or 1/6 of a turn.

For valves with rolled tops: Replace service valve cap tighten cap finger tight and then tighten one (1) additional wrench flat or 1/6 of a turn to properly seat the sealing surfaces. Subsequent installations will seat with 1/2 to 1 wrench flat of turning.

Gauge Ports: All Valves

Check for leaks at the schrader port and tighten valve core if necessary. Install plastic caps finger tight.

Ball Valves

On models with ball type valves use a 6" crescent wrench to rotate the valve stem 90° counter clockwise. Retighten valve cap to 6–8 ft. lbs. If torque wrench is not available, tighten cap finger tight and then tighten one (1/2) additional wrench flat.

REFRIGERATION PIPING & CHARGING

For extended piping over the recommended 75 feet please refer to Extended Length Refrigerant Piping Manual (Part # 42106111400).

Permanently ground unit in accordance with the National Electrical Code and local codes or ordinances. Use a copper conductor of the correct size from the grounding terminal in control box to a grounded connection in the service panel or a properly driven and electrically grounded ground rod.

Wiring Connections

Make all outdoor electrical supply (Line Voltage) connections with raintight conduit and fittings. Most codes require a disconnect switch outdoors within sight of the unit.

Route Line Voltage wiring through hole in the bottom of the Control Box and around the side of the shelf to connect to Contactor and Ground Lug.

Route Low Voltage wiring through entrance in bottom of control box and make ALL low voltage connections to the low voltage pigtailed in the area created by the shelf and the low-volt shield. (Two Yellow wires, AC or W,Y,O,BL, & R for HP). The pigtail wires have 600V insulation meeting approval for use in high voltage areas.

See Figures 5 thru 8 and Wiring Diagram on unit.

Use of Rigid Metal Conduit

It is recommended that wires be tied together or twisted together inside the conduit. This will minimize any buzzing type sounds that could be produced with high current loads, such as during starting. Under some conditions it may be necessary to use a hard start kit to eliminate problem noises.

Figure 5	A/C Control Box
-----------------	------------------------

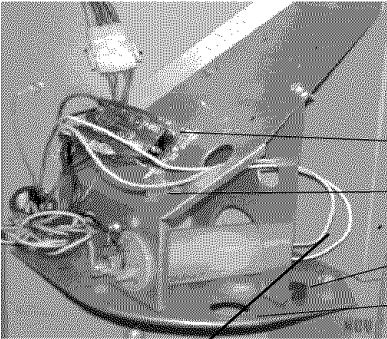

ALL Low Voltage Connections MUST be made in this AREA

Control Box Access

Remove the four screws. Cover is notched so it will slide out from under top edge of unit.

Figure 6	Heat Pump Control Box
-----------------	------------------------------

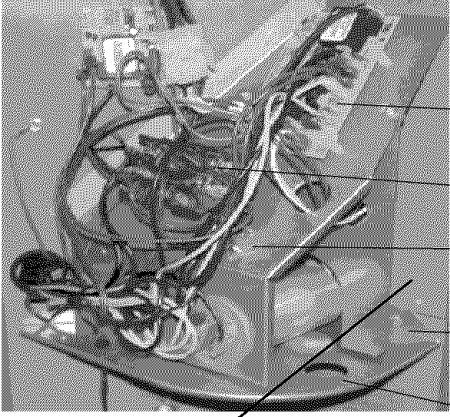

ALL Low Voltage Connections MUST be made in this AREA

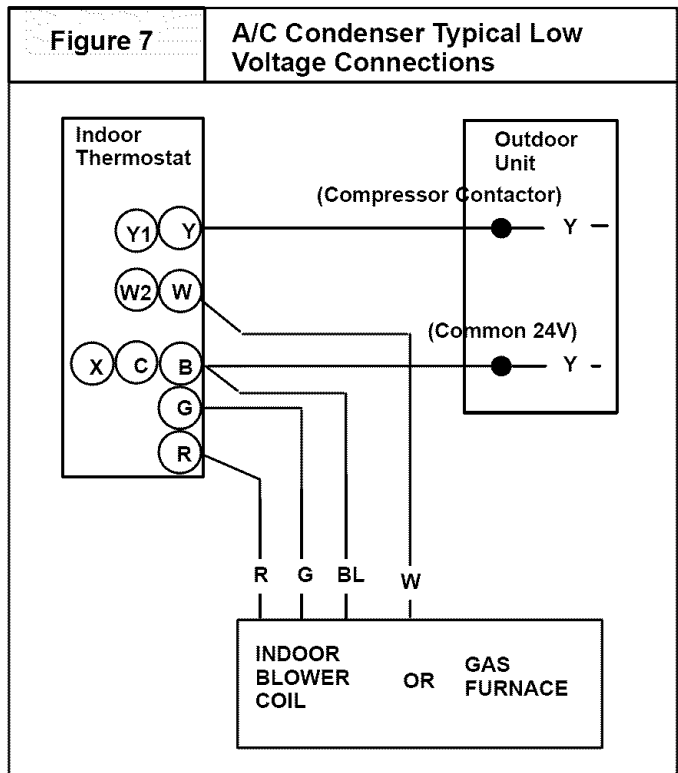
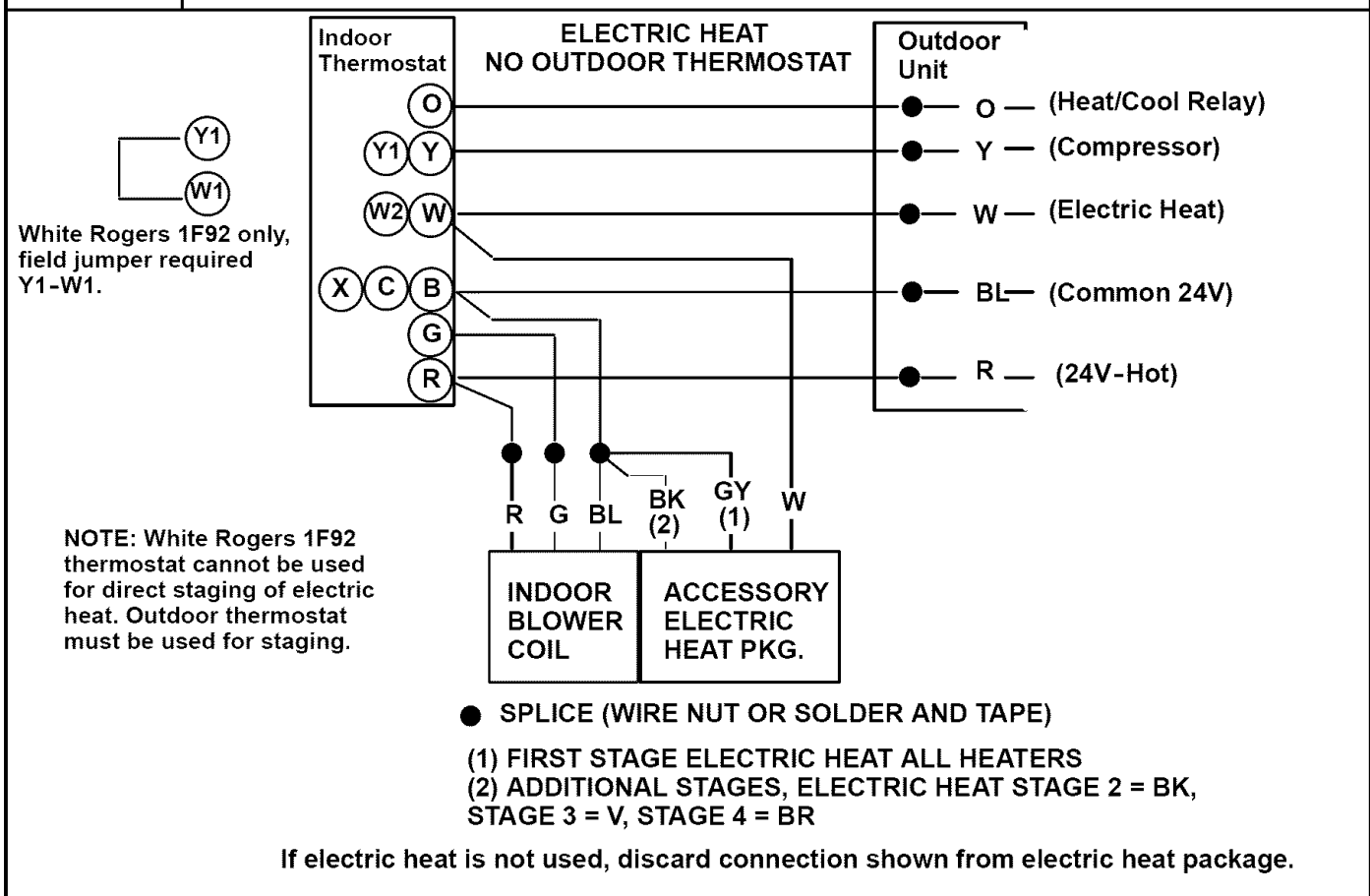

Figure 8 Heat Pump Typical Low Voltage Control Connections



Start-Up Procedure

Start-up Procedure

1. Close electrical disconnects to energize system.
2. Energize crankcase heater on units so equipped.
3. Set Thermostat selector switch to OFF.
4. Set room thermostat at desired temperature. Be sure setpoint is below indoor ambient temperature for cooling and above indoor ambient for heating.
5. Set the system switch of the thermostat on COOL and fan switch for continuous operation or AUTO, as desired. Operate unit for 15–20 minutes, then check the system refrigerant charge if it was necessary to adjust.
6. After the refrigerant charge has been adjusted, the system is now ready for continuous operation.

Final Refrigeration Charge Adjustment

Before any adjustment is made to the refrigerant charge, it is imperative that the air flow characteristics of the indoor blower be established.

When checking indoor air flow, it is important to remember that the blower will deliver a higher quantity of air across a dry coil versus a wet coil. Blower charts are calculated with a dry coil.

Recommended air flow for installations of cooling units and heat pumps is 350–450 CFM per ton (12,000 BTUH) through a wet coil. Refer to indoor unit installation instructions for proper methods of determining air flow and blower performance.

To Check System Refrigerant Charge (Superheat Method), Cooling Only

NOTE: On units with two speed fan control the fan will be on low speed if the temperature is below 83° F. Pull one of the yellow low voltage wires off the fan control and the unit will default to high speed fan for servicing. Reconnect wire after checking.

1. Attach an accurate temperature sensing device to the suction line approximately 4" – 6" away from the suction line service valve. The temperature sensing device should be clamped securely to the suction line, on a horizontal plane (between 9 & 3 O'clock) and insulated. Record the suction line temperature.

2. Measure and record the suction line refrigeration pressure. (Measure at the suction line service valve gauge port.) Using Temperature / Pressure Chart convert this pressure to the saturation refrigerant temperature. The difference between actual and saturated temperatures is the amount of superheat.

Figure 9 - Temperature / Pressure Chart

Temperature °F.	PSIG R-22	Temperature °F.	PSIG R-22	Temperature °F.	PSIG R-22
-6	19.3	19	41.9	41	70.0
-4	20.8	20	43.0	42	71.4
-2	22.4	21	44.1	43	73.0
0	24.0	22	45.3	44	74.5
1	24.8	23	46.4	45	76.0
2	25.6	24	47.6	46	77.6
3	26.4	25	48.8	47	79.2
4	27.3	26	49.9	48	80.8
5	28.2	27	51.2	49	82.4
6	29.1	28	52.4	50	84.0
7	30.0	29	53.6	55	92.6
8	30.9	30	54.9	60	101.6
9	31.8	31	56.2	65	111.2
10	32.8	32	57.5	70	121.4
11	33.7	33	58.8	75	132.2
12	34.7	34	60.1	80	143.6
13	35.7	35	61.5	85	155.7
14	36.7	36	62.8	90	168.4
15	37.7	37	64.2	95	181.8
16	38.7	38	65.6	100	195.9
17	39.8	39	67.1	105	210.8
18	40.8	40	68.5	110	226.4
				115	242.7

3. Measure and record the outside ambient air temperature.

4. Optimum performance will be achieved when the operating charge produces 15°-20° F suction superheat at compressor with 82° F outdoor ambient and 80° F dry bulb (67° F wet bulb) indoor temperature (ARI "B" test conditions) at rated airflow. If these conditions cannot be obtained, compare the calculated superheat value with the recommended values given in **Figure 13**.

Figure 10 - Recommended Superheat Values

Outside Air Temp ° F	Superheat °F Variator or Piston
65	38 -45
75	27 - 33
85	20 - 25
95	10 - 15
105	2 - 6

If the actual superheat readings are higher than shown, the system is most likely under-charged, and charge should be added. Add charge in 4 ounce increments, and recalculate superheat values. Continue adjusting charge until the actual superheat approximately matches the recommended values.

If the actual superheat readings are lower than shown, the system is most likely over-charged, and charge should be removed. Remove charge in 4 to 6 ounce increments, and recalculate superheat values. Continue adjusting charge until the actual superheat approximately matches the recommended values.

NOTE: Each time that charge is added or removed from the system, allow the system to run approximately 15 minutes before pressure and temperature readings are taken and superheat calculations made.

NOTE: Indoor Wet Bulb Temperature (and Relative Humidity) will alter superheat values. All readings should be at 50% humidity inside and 350 to 450 CFM per ton across the indoor coil.

Heating Checkout (Heat Pump Only)

1. Turn thermostat heat-cool switch to OFF. Turn thermostat fan switch to AUTO.
2. Turn on all power except 230 volt line to outdoor section.
3. Turn fan switch on thermostat to ON. Blower should run. Reset to AUTO; blower should turn off.
4. Set thermostat below room temperature. Turn selector switch to heat. Move thermostat above room temperature. Blower should run on heating speed and a click should be heard in the condensing unit outside (contactor closing). The sequencer coils for auxiliary heat should be energized. After approximately 30 seconds the contacts in the sequencers should close and the electric heat elements start heating. Allow 3 minutes for all heaters to come on.
5. Set system switch to OFF. Turn the thermostat above room temperature. Turn on the 230 volt power to the outdoor unit. Nothing apparent will be happening, but the crankcase heater is now energized. If the outdoor temperature is below 75 °F allow the unit to stay in this mode at least 6 hours. This is needed to vaporize any refrigerant that may be in the compressor oil.
6. Set the thermostat above room temperature. Move system switch to heat. Count to 5 (about 5 seconds). Turn the electric power off at the condensing unit disconnect switch. Check that there is no clattering or unusual noises. The outdoor fan blade should have started turning and a humming noise should have been heard from the compressor. The indoor fan should continue to run at its normal speed and electric elements continue to heat.
7. Wait 2 minutes, then repeat the procedure and recheck the same things in case you missed something during the first power application.
8. With the unit operating, close all doors, windows, storm windows, and openings to the house. Set the thermostat to the desired setting. Set outdoor thermostat (if installed) to balance point of house. If temperature of house is at least two degrees below thermostat setting, heat pump and auxiliary heat not controlled by outdoor thermostats will continue to run until room temperature is approximately 2° below thermostat set point. Auxiliary heat light should go out and auxiliary heat cycle off. Heat pump should continue to run until thermostat reaches set point.

To Check System Refrigerant Charge (Heating Mode)

The recommended method of addition or removal of charge in the heating mode is by weight. The system operation may be checked against the performance charts. Remember, indoor airflow must be approximately 400 CFM per ton to compare operation to performance charts.

Defrost System (Heat Pump Only)

Time / Temperature Type:

The defrost system is electronic with an adjustable time interval of 90, 60, or 30 minutes. It is factory set at 60 or 90 minutes. At the selected time interval with the outdoor coil temperature at approximately 28°F, the system will defrost. When the sensor sees the correct rise in the outdoor coil temperature or after approximately 10 minutes, the defrost will be terminated.

Demand Type:

The defrost frequency is demand based on the coil reaching a temperature of 35 °F for a minimum of 34 minutes and a maximum of 6 hours of run time. The actual time interval will vary depending on the outdoor temperature which the control is also sensing. This can not be adjusted, but the defrost termination temperature can be. Factory setting is 50°F for termination or after approximately 14 minutes, the defrost will be terminated. Temperature can be set higher if all the ice is not melting off the coil.

In some areas, with high humidity, the time interval or temperature termination may require adjustment for complete removal of ice from the coil. For best economy, always set to the longest interval or lowest temperature that will keep the coil clear of ice.

NOTE: The term ice means hard but not frost. During normal operation, the coils may become coated with frost until they are solid white. The time interval for the defrost should be set so the frost and ice melt off completely without hard ice building up on the coil.

Defrost Control

Time Interval Adjustment (Except Demand Defrost)

To adjust defrost frequency, turn off all power to the Heat Pump. Remove control box cover and locate the electronic defrost control board.

The defrost control board has a jumper clip that fits over two pins. To change the time interval, remove the jumper clip and place it on pins for the desired time interval, 30, 60 or 90 minutes.

Temperature Adjustment (Demand Defrost)

Turn off all power to the Heat Pump. Remove control box cover and locate the electronic defrost control board.

The defrost control board has a jumper clip that fits over two pins. To change the temperature termination, remove the jumper clip and place it on pins for the desired interval of 50, 60, 70 or 90 degrees.

Functional Check (Demand Defrost)

To force a defrost cycle place the jumper on the TEST pins. This will cause an accelerated test defrost cycle at 240 times the normal speed (14 min. = 3.5 secs). Reversing valve will energize, condenser fan stop and electric heat should come on. This will verify the switching functions of the board.

Maintenance

WARNING

Electrical Shock Hazard.

Shut off electric power at fuse box or service panel before making any electrical connections.

Failure to shut off electric power can result in, property damage, personal injury and/or death.

Condensate Drain

During the cooling season check at least monthly for free flow of drainage and clean if necessary.

Cleanliness

These tips will help you keep your air conditioner looking better and working more efficiently:

1. Free air flow is essential. Keep the outdoor coil clean and free of restrictions. Keep fences, shrubs, snow drifts and any other obstructions at least two feet from all coil air inlets.
2. Keep the coil free of grass clippings, weeds and other debris. **BE SURE TO TURN OFF ELECTRICITY BEFORE CLEANING!**

Coils may require cleaning. The coil should always be cold when cleaning. Use an alkaline based cleaner only. Cleaning a hot coil or using an acid based cleaner will remove the paint from the fins and may clog the coil.

3. Never use a weather cover over the outdoor unit unless it is a ventilated type or made of breathable fabric that will allow moisture to evaporate rapidly. A cover that holds moisture in the unit will cause more rust build-up and damage than normal exposure to weather.

Figure 11

Adjusting Defrost Time - Time Temperature Type

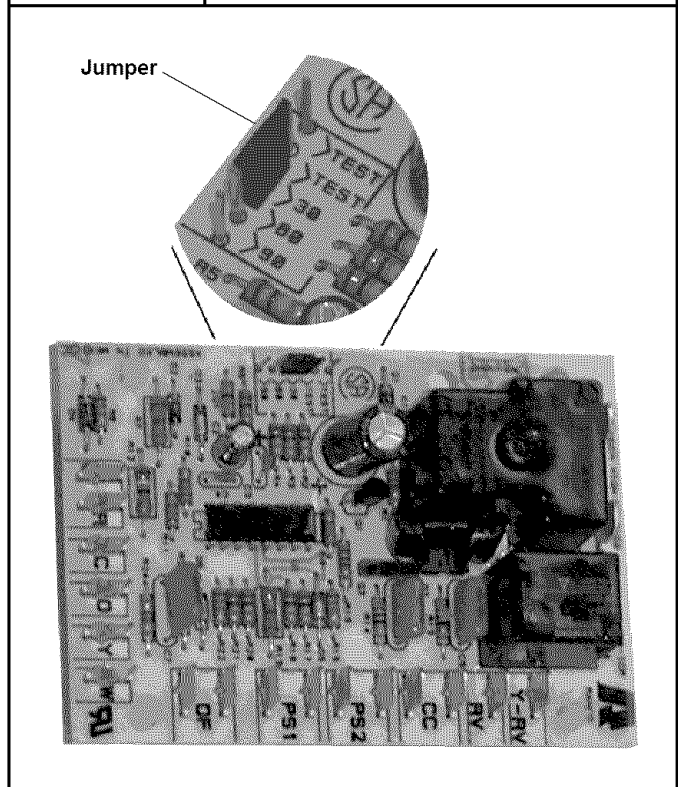
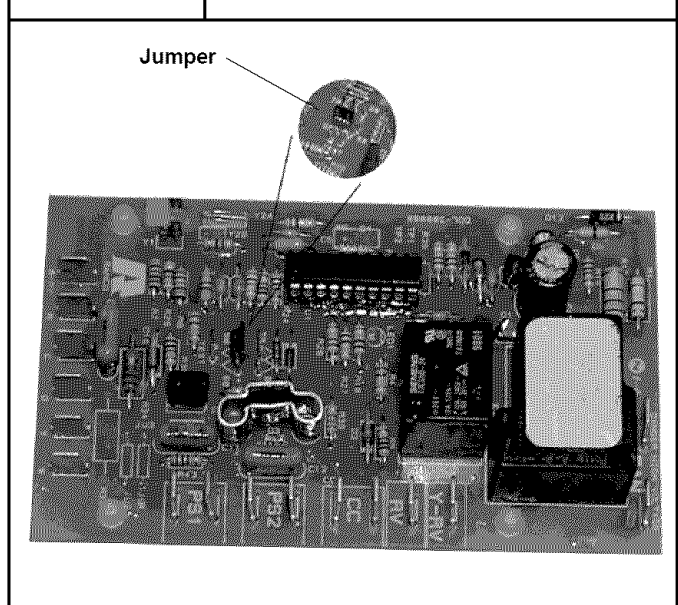
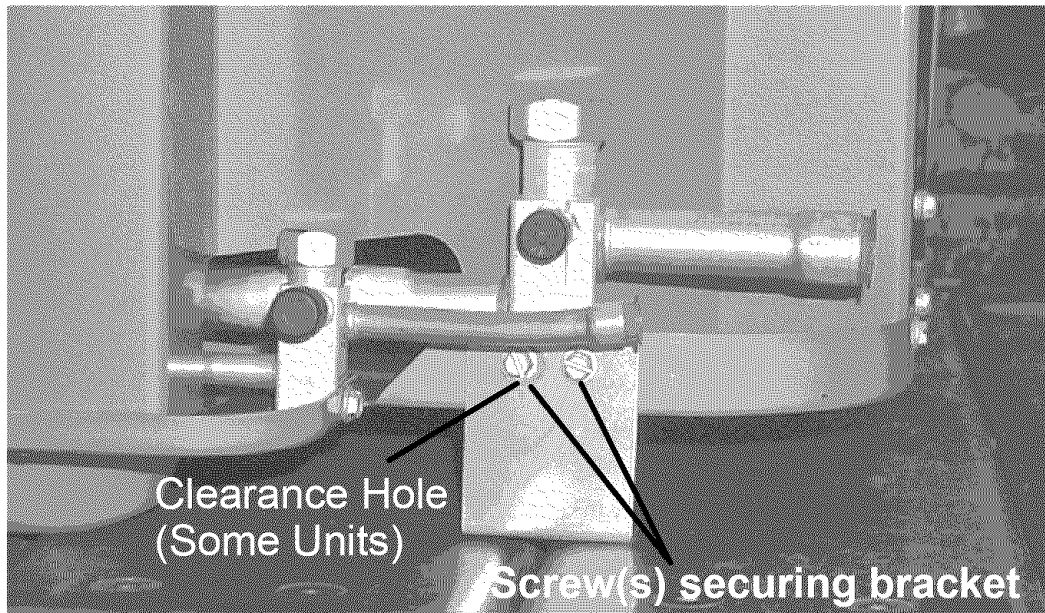

Figure 12

Adjusting Defrost -Demand Type





SHIPPING BRACKET

A shipping bracket has been added to some chassis to increase the stacking height for improved warehousing.

If present the bracket may be left in place or removed by the installer.

NOTE: The bracket is installed using the same screw(s) that secure the service valve. If only one screw is used there is a clearance hole that fits over one screw securing the suction valve. If bracket is removed. **MAKE SURE SCREW(S) IS REINSTALLED.**