

OWNER'S MANUAL

MODEL NOS.

UltraSoft 800
625.388800

UltraSoft 880
625.388880

Caution:

Read and Follow
All Safety Rules and
Operating Instructions
Before First Use of
This Product.

If you have questions when
installing, operating or main-
taining your softener, and
when setting the timer, call
this toll-free number...

1-800-426-9345
M - F, 7 am - 8 pm, CST

For repair or replacement
parts, call this toll-free num-
ber...

1-800-366-7278

See back cover for other
Sears service numbers.

www.KenmoreWater.com

SAVE THIS MANUAL



UltraSoft Water Softeners

with High Performance Valve

- ◆ Warranty
- ◆ Start Up / Setting Timer
- ◆ How It Works
- ◆ Care Of
- ◆ Specifications
- ◆ Repair Parts



Systems Tested and Certified by NSF International
against NSF/ANSI Standard 44 for softener performance
and the chemical reduction claims specified on the perfor-
mance data sheet.

Use the plastic bag and tie provided, to hang manuals
nearby the softener for future reference.

Sears, Roebuck and Co., 3333 Beverly Road, Hoffman Estates, IL 60179 USA

W
A
R
R
A
N
T
Y

SEARS RESIDENTIAL WATER SOFTENER

FULL ONE YEAR WARRANTY ON WATER SOFTENER

For one year from the date of purchase, when this water softener is installed and maintained in accordance with our instructions, Sears will repair, free of charge, defects in material or workmanship in this water softener.

FULL THREE YEAR ELECTRONICS WARRANTY

For a period of three years from date of purchase, Sears will replace the BRINE TANK LIGHT, ELECTRONIC BOARD, SENSOR HOUSING, WIRING HARNESS, TRANSFORMER, MICRO SWITCH, DRIVE MOTOR, OR POWER CABLE, should they be defective in material or workmanship.

FULL TEN YEAR WARRANTY AGAINST LEAKS

For ten years from the date of purchase, Sears will furnish and install a new current model water softener tank or salt storage drum, free of charge, if either the tank or drum develop a leak.

TO OBTAIN WARRANTY SERVICE, SIMPLY CONTACT THE NEAREST SEARS SERVICE CENTER THROUGHOUT THE UNITED STATES. This warranty applies only while this product is in use in the United States.

This warranty gives you specific legal rights, and you may have other rights which vary from state to state.

Sears, Roebuck and Co., D/817 WA, Hoffman Estates, IL 60179

If you want your water softener professionally installed, talk to your Sears Salesman. He will arrange for a prompt, quality installation by Sears Authorized Installers.

SEARS INSTALLATION POLICY

All installation labor arranged by Sears shall be performed in a neat, workmanlike manner in accordance with generally accepted trade practices. Further, all installations shall comply with all local laws, codes, regulations, and ordinances. Customer shall also be protected, during installation, by insurance relating to Property Damage, Workman's Compensation and Public Liability.

SEARS INSTALLATION WARRANTY

In addition to any warranty extended to you on the Sears merchandise involved, which warranty becomes effective the date the merchandise is installed, should the workmanship of any Sears arranged installation prove faulty within one year, Sears will, upon notice from you, cause such faults to be corrected at no additional cost to you.

FACTS AND FIGURES TO KEEP

Fill in the blanks below and keep this book in a safe place so you always have these facts.

Water Softener Model No.† _____
 Serial Number _____
 Date Installed _____
 Water Hardness _____ Grains Per Gallon
 Iron Content _____ Parts Per Million
 pH _____ Taste And/Or Odor _____
 Water Pressure _____ Pounds/Square Inch
 Water Flow Rate _____ Gallons Per Minute

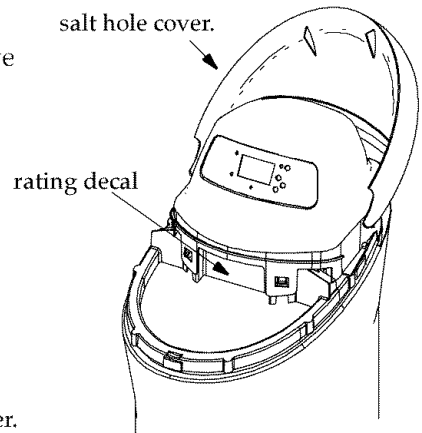

† The model number is on the rating decal, located on the rim, under the salt hole cover.

**T
A
B
L
E

O
F

C
O
N
T
E
N
T
S**

SECTION 1		WATER SOFTENER START UP	PAGE NO.
A.	Safety Guides -----		1-1
B.	Check List of Step-By-Step Guides To Install -----		1-2
C.	Program The Timer -----		1-3, 1-4
D.	Sanitizing The Water Softener -----		1-5
E.	Adding Salt to The Storage Tank -----		1-6
SECTION 2		HOW YOUR WATER SOFTENER WORKS	
A.	Faceplate Timer Features -----		2-1 to 2-3
B.	Soft Water Service and Regeneration -----		2-4 to 2-6
SECTION 3		CARE OF YOUR WATER SOFTENER	
A.	Salt: Adding to Storage Tank / Salt Bridge -----		3-1
B.	Keeping The Water Softener Clean -----		3-2
C.	Protect The Water Softener From Freezing -----		3-3
D.	Checklist (Not Getting Soft Water) -----		3-4
SECTION 4		ABOUT YOUR WATER SOFTENER	
A.	Dimensions / Specifications -----		4-1, 4-2
SECTION 5		SERVICE TECH. INFORMATION	
A.	Troubleshooting -----		5-1 to 5-4
B.	Rotary Valve Service -----		5-5
C.	Water Flow Through The Softener Valve -----		5-6 to 5-8
SECTION 6		REPAIR PARTS FOR WATER SOFTENER	
A.	Water Softener Complete -----		6-1, 6-2
B.	Brine Valve Assembly -----		6-3, 6-4
C.	Valve Assembly -----		6-5, 6-6

A. SAFETY GUIDES

▲ Read all steps, guides and rules carefully before installing and using your new water softener. Follow all steps exactly to correctly install. Failure to follow them could cause personal injury or property damage. Reading this book will also help you to get all of the benefits from your water softener.

▲ Your water softener will remove hardness minerals and “clear water” iron* from water, up to the limits shown on page 4-1. It will not remove other types of iron, acids, tastes and odors, etc. It will not purify polluted water or make it safe to drink.

▲ Protect the softener and piping from freezing. Damage from freezing voids the softener warranty. See page 3-3.

CAUTIONS

PLEASE READ AND COMPLY WITH THE FOLLOWING GUIDES TO PREVENT DAMAGE TO THE SOFTENER OR OTHER PROPERTY, PERSONAL INJURY, OR POSSIBLE FATAL SHOCK.

▲ THIS SOFTENER WORKS ON 24 VOLTS ONLY. BE SURE TO USE ONLY THE TRANSFORMER INCLUDED, AND PLUG IT INTO A NOMINAL 120V, 60 CYCLE HOUSEHOLD OUTLET THAT IS GROUNDED AND PROPERLY PROTECTED BY AN OVERCURRENT DEVICE SUCH AS A CIRCUIT BREAKER OR FUSE. IF THE TRANSFORMER IS REPLACED, USE ONLY AN AUTHORIZED SERVICE, CLASS II, 24 VOLT, 10 VA, TRANSFORMER.

▲ Unplug the transformer right away if the power cable should become damaged or frayed. Make repairs, or replace the transformer, before plugging back into the power outlet.

▲ Always unplug the softener from electrical power before removing outer valve covers.

▲ This system is not intended to be used for treating water that is microbiologically unsafe or of unknown quality without adequate disinfection before or after the system.

* The capacity to reduce clear water iron is substantiated by WQA test data.

B. CHECK LIST OF STEP-BY-STEP GUIDES TO INSTALL

To be sure you have done all the steps to install the softener, read the following list. Refer to the Installation Manual, part no. 7258997, for step-by-step guides.

Page numbers referred to are in the *Installation Manual* unless otherwise noted.

- ✔ Is the house water flow going INTO the softener valve INLET? Trace piping to be sure. See pages 2-4 and 2-5.
- ✔ Is the plumbing bypass valve (or 3 valves) set for SERVICE? Bypass valve(s) should always remain in soft water service position. Position in "bypass" only if needed for softener repairs. See FIG. 14, page 4-1 of this manual.
- ✔ Is the valve drain hose connected the right way, and without sharp bends or kinks that could stop or reduce water flow? See page 3-5 in the installation manual.

Page numbers referred to are in the *Installation Manual* unless otherwise noted.

- ✔ Is the transformer plugged into an **inside**, always live, grounded, 120V-60Hz electrical outlet? See pages 3-8 and 3-9 in the installation manual, and the wiring schematic on page 5-1 of this manual.
- ✔ Be sure to restart the water heater. See page 3-9.

California Efficiency Requirement

Your Kenmore Water Softener has a "High Efficiency" feature with an "ON" or "OFF" setting. This softener setting is shipped in the "OFF" position, which utilizes the maximum rated capacity while most often achieving maximum salt efficiencies. When installing this unit in the State of California, you **MUST** turn this setting to the "ON" position which may initiate more frequent recharges, however it will operate at 4000 grains per pound of salt or higher.

If you wish to turn the Salt Efficiency feature "ON" ("E" icon will show in display), follow the instructions in the Faceplate Timer Features, Section 2 of this manual.

NOTE: Codes in the state of Massachusetts require installation by a licensed plumber. For installation, use plumbing code 248-CMR of the Commonwealth of Massachusetts.

FIG. 1

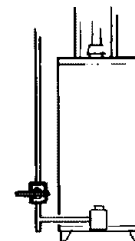
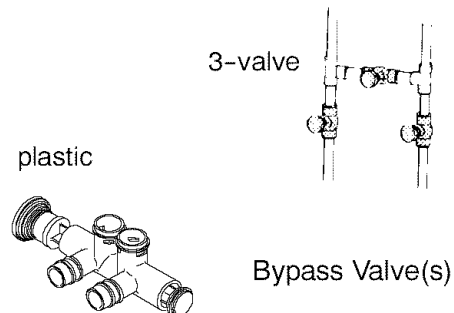
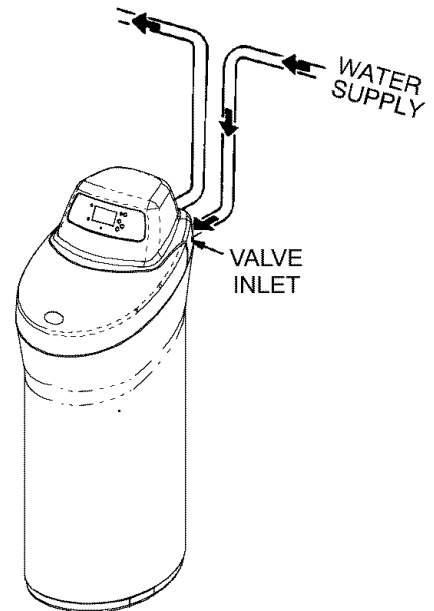

C. PROGRAM THE TIMER

FIG. 2

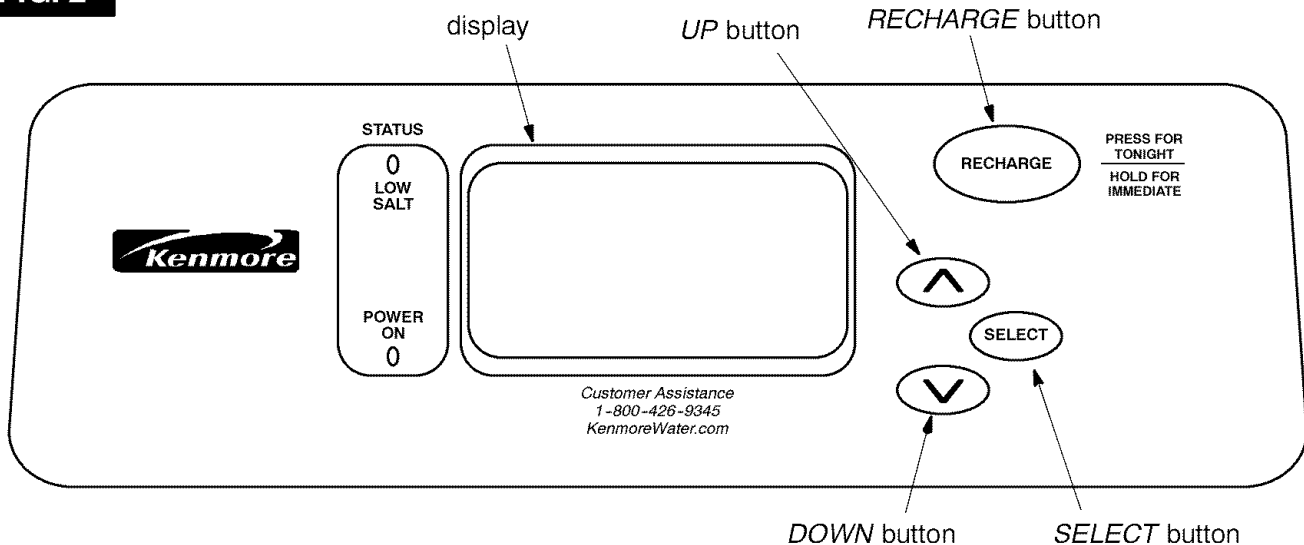

When the transformer is plugged in, a welcoming screen will show along with the model code HF45, and a test number (example: G1.0) for 10 seconds. Pressing the SELECT key will advance to next screen. Pressing any other key will keep the welcome screen on for another 10 seconds. Next, choice of language. Then, 12:00 PM and PRESENT TIME appear.

Model: HF45
Version: G1.0

Thank You
For Choosing Kenmore
...For Quality Water

Present Time:
12:00 PM

▲▼ CHANGE SELECT

Notes:

If - - - shows in the display, press the UP ▲ or DOWN ▼ button until HF45 shows. Then, press the SELECT button to set, and change to the Language display.

To check the model code, unplug the transformer at the wall outlet and plug in again. **if other than HF45 shows, see page 5-3 to reset.**

SOUND "BEEPER": A "beeper" sounds while pressing buttons for timer set-up. One beep signals a change in the face plate display. Repeated beeps mean the timer will not accept a change from the

button you have pressed, telling you to use another button. For example, while setting the hardness (step 2), the beeper sounds repeatedly when the display reaches 1 using the DOWN button, or the highest hardness setting using the UP button.

1. SET LANGUAGE

■ Press the UP / DOWN buttons to move the black bar over the language preferred. Press SELECT to enter and go to next screen.

2. SET PRESENT TIME OF DAY

If the words *PRESENT TIME* do not show in the display, press the SELECT button (FIG. 2) until they do.

■ Press the UP / DOWN buttons to set the present time. Press UP to set the clock ahead; press DOWN to set the clock back.

If the present time is between noon and midnight, be sure *PM* shows.

If the present time is between midnight and noon, be sure *AM* shows.

Each press of the UP /DOWN buttons changes the time by one minute. Holding the buttons in changes the clock 16 minutes each second.

Present Time:
4:58 PM

▲▼ CHANGE SELECT

Present Time:
11:36 AM

▲▼ CHANGE SELECT

D. SANITIZE THE WATER SOFTENER

Care is taken at the factory to keep your water softener clean and sanitary. Materials used to make the softener will not infect or contaminate your water supply, and will not cause bacteria to form or grow. However, during shipping, storage, installing and operating, bacteria could get into the softener. For this reason, sanitizing as follows is suggested^① when installing.

1. The first time you sanitize your softener, be sure to do *all* steps in the installation manual, and on pages 1-2, 1-3 and 1-4 of this manual first. Note: Be certain the bypass valve is pulled out to "service" position.
2. Lift the salt hole cover and use a pail to fill the salt storage tank with 3 gallons of water.
3. Remove the brinewell cover (FIG. 2 and 3) and pour about 3/4 ounce, or 1 to 2 tablespoons, of common 5.25%, *unscented*, household bleach (Clorox, Linco, BoPeep, White Sail, Eagle, etc.) in the softener brinewell.
4. Press the **RECHARGE** button and *hold for 3 seconds* to start a recharge. This first recharge does several things.

- It draws the bleach into and through the softener to sanitize it.
- It fills the salt tank to the water level needed.
- It gets all the air out of the resin tank.
- It prepares the resin bed (see page 2-3) for service and flushes residual chlorine from the softener.

Notes:

This recharge takes about 2-1/2 or 2-3/4 hours, depending on the salt type setting (page 1-4).

You can sanitize the softener *with or without* salt in the storage tank.

FIG. 3

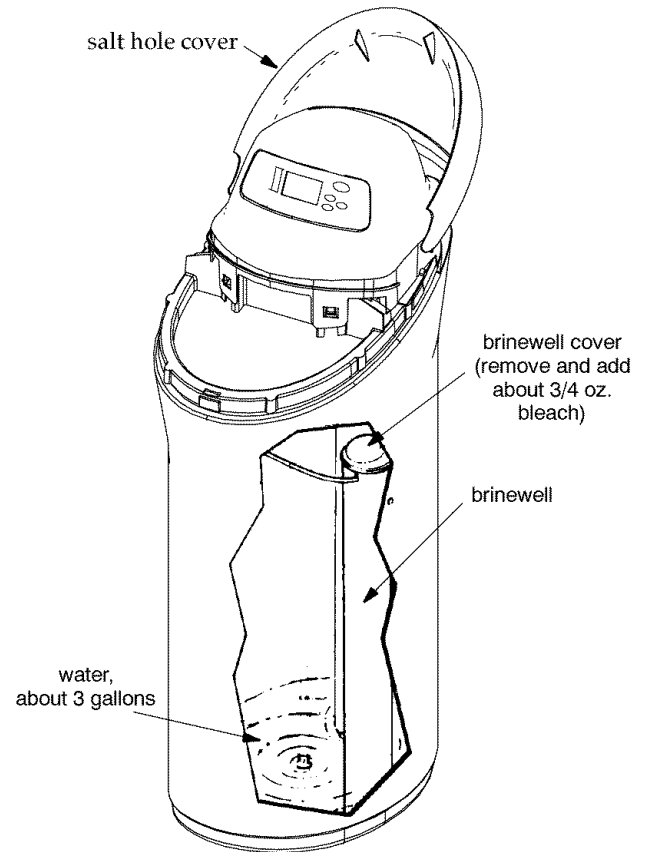

^① Recommended by the Water Quality Association. On some water supplies, the water softener may need periodic disinfecting.

E. ADDING SALT TO THE STORAGE TANK

Brine (salt dissolved in water) is needed for each and every regeneration. The water for making brine is metered into the salt storage tank by the softener. You must keep salt in the tank, but because the water softener is very efficient, it is not necessary to keep it full. **In humid areas**, it is best to fill the storage tank one quarter to one half full, and to refill it more often. Salt bridging (see page 3-1) occurs more often when conditions are humid.

Use NUGGET or PELLET water softener salt. **DO NOT** use rock salts, as they have dirt and sediments that will stop the softener from working.

When the salt cover is opened, the tank light turns on and the display automatically goes to the Set Salt Level display.

Before adding salt, be sure the brinewell cover is in place on the top of the brinewell. It is recommended to set the salt monitor system, although it is not required for proper operation (see page 2-2).

POTASSIUM CHLORIDE, alternate to salt: The design of this softener allows for the use of potassium chloride in place of salt (sodium chloride).

1) Place only one bag of KCl in your softener at a time (the salt storage tank should contain no more than 60 pounds of KCl at any one time).

2) A softener using KCl should not be placed in areas with temperature fluctuations and high humidity (KCl will harden in these environments and may make the softener inoperable).

3) Check the brine tank and brinewell (black tube in salt storage tank) monthly. If hardening is present, pour small amounts of warm water on hardened areas until they loosen.

4) **If you do use potassium chloride, see page 2-2 to set the timer for its use.**

Note: The salt monitor system, page 2-2, is calibrated to the density of nugget or pellet water softener salt. The monitor will not work as accurately with other types of salt including rock and solar.

WATER SOFTENING SALT WITH IRON REMOVING ADDITIVES — Some salts have an additive to help the softener handle iron in the water supply. These salts may be used if your water supply has a high iron content, although it is recommended to use Sears Resin Bed Cleaner 42-34426, for periodic treatments to keep your resin bed clean. This is available at your local Sears store.

FIG. 4

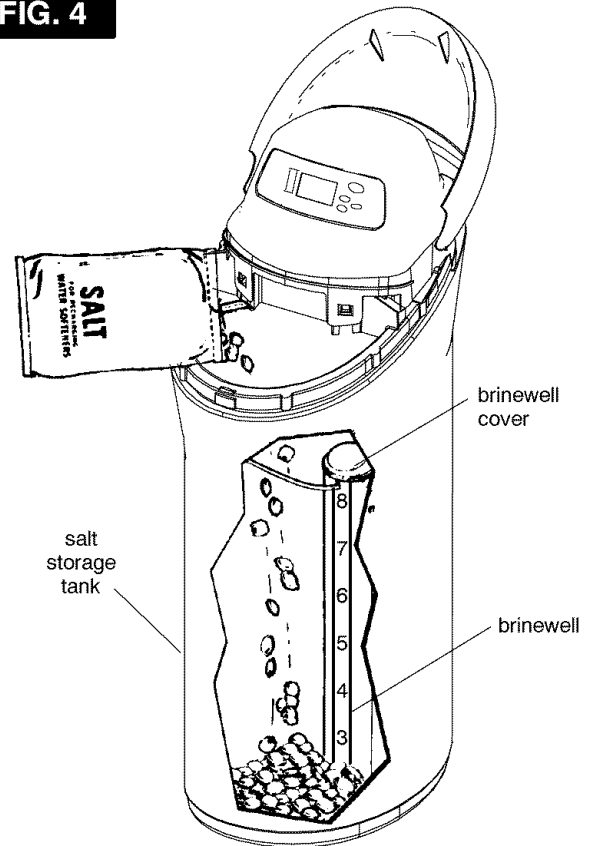

Sodium information: Water softeners using sodium chloride for regeneration add sodium to the water. Persons who are on sodium restricted diets should consider the added sodium as part of their overall sodium intake. For example, if your water supply is 15 grains hard, you would have to drink 3 quarts of softened water to consume 335 milligrams of sodium. That is equivalent to eating 2-1/2 slices of white bread.

Persons who are concerned about their drinking water should consider a Kenmore Drinking Water System that will remove or reduce in excess of 90% of the sodium and other drinking water contaminants.

SECTION 2

A. FACEPLATE TIMER FEATURES

► **EXTRA RECHARGE**

Sometimes, a manually started regeneration (recharge) may be desired, or needed. Two examples are:

- You have used more water than usual (guests visiting) and you may run out of soft water before the next timer started regeneration.
- You did not refill the softener with salt before it was gone. After you refill with salt:

You can start a regeneration right away, or you can set the timer to regenerate at the next 2:00 AM (or other preset recharge time). Do the following.

► **RECHARGE NOW**

Press the RECHARGE button and *hold* until *RECHARGE screen shows in the display and the green recharge LED is flashing. This screen shows the regeneration time and cycle time remaining. After regeneration, you will have soft water again.

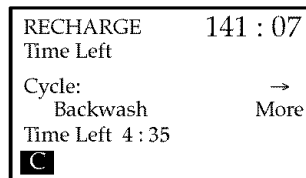

*Note: If the CLEAN feature is set to ON, a cleaning backwash ("C" icon and *Backwash* or *Rinse* flashes in the display, along with the minutes of the clean cycle remaining) precedes the recharge.

► **RECHARGE TONIGHT**

Press and release (*do not hold*) the RECHARGE button. RECHARGE TONIGHT flashes in the display, the green recharge LED is on and the softener begins regeneration at the next preset recharge time. Press and release the ON/OFF-HOLD button once more if you decide to cancel the regeneration, RECHARGE TONIGHT will no longer be displayed

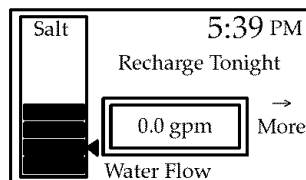

on the screen and the green recharge LED will turn off.

► **MENU SELECTIONS:**

The timer has menu driven programming. To get to the main menu from the normal operating screen view, press the SELECT button. Once in a menu, pressing the UP or DOWN buttons will move the black bar over the menu choices, and pressing the SELECT key will enter the individual menus which are described below. By placing the black bar over the word "Back" and pressing SELECT, will move back one screen. By placing the black bar over the word "Exit" will return the screen to the normal operating screen.

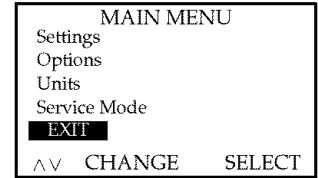

■ **SETTINGS:** In this menu, changes can be made to Language, Present Time, Hardness and Recharge Time.

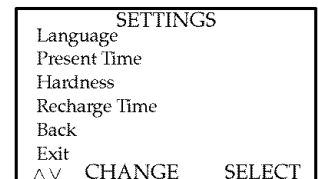

Language for all screens can be in English, Spanish or French. Move the black bar to Language, and press SELECT. Move black bar over your choice and press SELECT. Screen returns to Settings Menu.

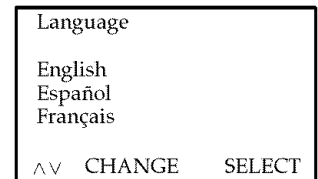

NOTE: If Language has been mistakenly changed, press SELECT button until you see English, Español and Français in the display. The maximum number of presses is six and it could be fewer depending on which screen was displayed. Use the UP or DOWN arrows to place the black bar over language desired. Press SELECT twice to return to normal operating screen.

Present Time changes the current time of the faceplate. Be sure to have correct AM or PM time, or softener will recharge at the wrong time of day. One press of the UP or DOWN button changes the time by one minute intervals. Press and hold either the UP or DOWN arrow, to scroll through the time at a faster rate.

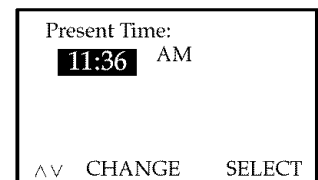

A. FACEPLATE TIMER FEATURES

Hardness changes the hardness setting. Default is 25. Pressing the UP or DOWN button changes the number by one. Once correct number is shown, press SELECT to change to new setting.

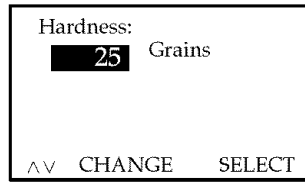

Recharge Time is the when the softener is scheduled to start a recharge. Default is 2:00 AM. Using the UP or DOWN arrows changes the time by one hour increments. When the desired time is shown, press SELECT to change and return to Settings menu.

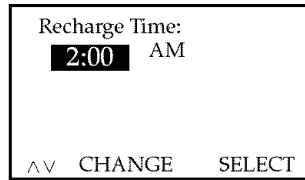

OPTIONS: Choices are Salt Options, QuickCharge, Rinse Option and Recharge Count. Salt Options has several selections:

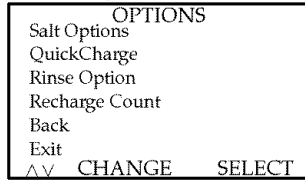

When salt is added to tank, **Salt Level** must be changed to the new salt level in the tank. Use the UP or DOWN arrows to set. Observe the bars and the corresponding number value in the display. This number must match the number on the brine tube in the brine tank that the salt level is closest to. When the correct number is displayed, press the SELECT key. Screen will return to Salt Options screen. The salt monitor is an estimate of your salt level; accuracy depends on type of salt used and regeneration characteristics. NOTE: The display automatically defaults to this screen and the tank light turns on when the salt cover is opened on the softener and returns to normal operating screen when salt cover is closed.

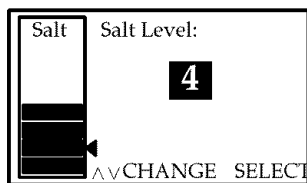

Salt Alert Level is the level at which you want your softener to signal that the salt level is low. When salt level drops to this point, the low salt LED will flash on the faceplate. Move the small cursor up or down by pressing the UP or DOWN arrows and observe the number in the display. When the correct number is displayed, press the SELECT key. Screen will return to Salt Options screen.

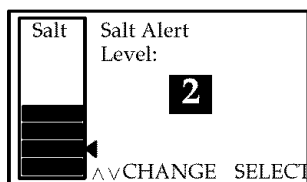

Salt Type allows you to chose between sodium chloride (NaCl), which is regular softener salt, or potassium chloride (KCl), which is an alternative to sodium chloride. KCl should be used in accordance to the following steps to help give you years of maintenance free service.

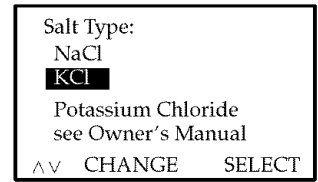

- 1) Place only one bag of KCl in your softener at a time (the salt storage tank should contain no more than 60 pounds of KCl at any one time),
- 2) A softener using KCl should not be placed in areas with high temperature changes or high humidity (KCl will harden in these environments and may make the softener inoperable),
- 3) Check the brine tank and brinewell (black tube in salt storage tank) monthly. If hardening is present, pour small amounts of warm water on hardened areas until they loosen.
- 4) Be sure to set the correct salt type depending on which salt type is used (NaCl or KCl).

Use the UP or DOWN arrows to toggle between NaCl or KCl and press SELECT to enter information and return to Salt Options screen. If KCl is selected the normal operating screen will display KCl in the lower right hand corner of the display.

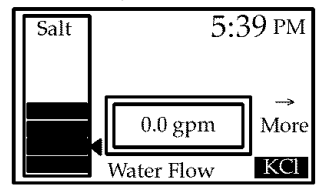

Salt Efficiency has three options.

High Performance, **Salt Efficient** and **Max. Salt Efficient**. Using Sodium Chloride (NaCl) with these options, High Performance allows the softener to operate at a normal efficiency rate. This is good for households with high water usage. At the Salt Efficient setting, the softener operates at a minimum of 4,000 grains per pound of salt and set at Max. Salt Efficient, the softener operates at a minimum of 4,250 grains per pound of salt. Use the UP or DOWN arrows to move the black bar over your choice. Press SELECT, and a warning screen will appear. Changing this setting will affect performance. Choose either Cancel or Accept. Display will return to Salt Options menu, press SELECT once more to return to normal operating screen. NOTE: The state of California requires a setting of Salt Efficient or Max. Salt Efficient.

A. FACEPLATE TIMER FEATURES

When selecting Quick-Charge as an option, the softener will automatically recharge if 95% of capacity has been unexpectedly used and there is less than 1/2 gpm flow. The recharge will last 30 minutes and give the softener approximately 5,000 grains capacity. The softener will also run through a normal recharge cycle that night. Move the black bar over On or Off and press SELECT. Display will return to Salt Options menu, press SELECT once more to return to normal operating screen. A "Q" will be displayed on the normal operating screen if this option is chosen.

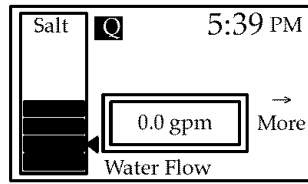

Rinse Option has three choices. WaterSaver reduces by 20% the amount of water used during regeneration. This option should only be used if feed water is from a municipal supply, 8 grains of hardness maximum, and no iron present. At Normal setting the softener operates at normal water usage for regenerations, and Clean Feature adds an extra backwash and fast rinse in the regeneration cycle. Clean feature may be used when feed water has higher sediment or iron content. Default setting for UltraSoft 800 is "Normal", for UltraSoft 880, default is "Clean". Move the black bar over choice and press SELECT. Display will return to Salt Options menu, press SELECT once more to return to normal operating screen. A "W" or "C" will be displayed on the normal operating screen if WaterSaver or Clean Feature option is chosen.

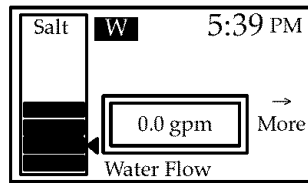

Recharge Count keeps track of the number of recharges, either from initial set up, or since last reset. Use the UP or DOWN arrows to move the black bar over Yes or No and press SELECT. On the "More" screen, Avg. Salt/Rchg is reset to 0 also, if yes is selected. Display will return to Salt Options menu, press SELECT once more to return to normal operating screen.

UNITS: Choices are 12/24 Hour Clock, Gallons/Liters, Grains/PPM and Pounds/Kilograms.

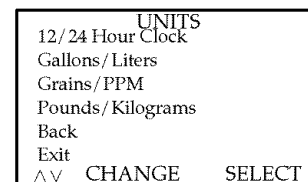

12/24 Hour Clock option allows you to choose how the time is displayed on the normal operating

screen. Move the black bar over 24 Hour or 12 Hour and press SELECT. Display will return to Units menu, press SELECT once more to return to normal operating screen. If 12 Hour clock is chosen, an AM or PM will be displayed, be sure that time is correctly set for AM or PM.

Gallons/Liters option allows you to choose how the water usage is displayed on the normal operating screen. Move the black bar over Gallons or Liters and press SELECT. Display will return to Units menu, press SELECT once more to return to normal operating screen. Display will show either "lpm" for liters per minute or "gpm" for gallons per minute.

Grains/PPM option allows you to choose either grains or parts per million. Move the black bar over Grains or PPM and press SELECT. Display will return to Units menu, press SELECT once more to return to normal operating screen. All settings will be measured in grains or parts per million.

Pounds/Kilograms option allows you to choose either pounds or kilograms of salt used. Move the black bar over Pounds or Kilograms and press SELECT. Display will return to Units menu, press SELECT once more to return to normal operating screen.

SERVICE MODE:

Choices are Time Options, Diagnostics, Set Model and Factory Defaults.

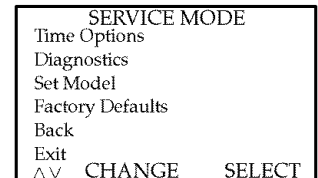

Time Options has several selections. Clean Time, Backwash Time, Fast Rinse Time and Max Days/Recharges can be modified to different time settings. Use the UP or DOWN arrows to change the number of minutes desired for each cycle and press the SELECT key. Screen returns to Time Options menu. Press SELECT once more to return to normal operating screen.

Diagnostics is a view only screen that displays information about the softener. What position the valve is in, if the motor is on or off, is the position switch open or closed, is some of the information on this screen (see pages 5-2 and 5-3).

At this time HF45 is the only model available in the Set Model screen.

Factory Defaults resets all settings. You must reprogram the timer to any customized settings if this option is used.

► KENMORE'S ULTRA CLEANSING FEATURE (UltraSoft 880 only)

The ultra cleansing feature keeps larger particles of sediment from entering the home's plumbing system. As water passes through the softener, the larger sediment particles are collected in the integrated basket and then rinsed to the drain before each regeneration. The ultra cleansing feature provides added protection for water-using appliances by reducing the chance of larger particles entering the various product's valves and screens.

An extra backwash will be pre-programmed into the electronics by the factory (see "Clean Feature" in Section 2 "Faceplate Timer Features" in this manual). This extra backwash will help keep the ultra cleansing feature screen clean.

Important: The ultra cleansing feature is not intended to replace pretreatment filtration. For problem water applications, additional sediment filtration is recommended.

Sears offers a full-line of dedicated sediment filtration products including the Whole Home Filter and Automatic Clarifying Filter.

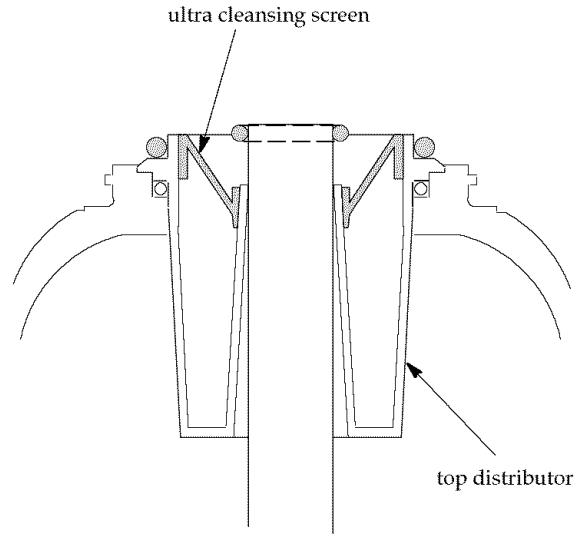

B. SOFT WATER SERVICE and REGENERATION

SERVICE

When the softener is giving you soft water, it is called "Service". During service, hard water comes from the house main water pipe into the softener. Inside the softener resin tank is a bed made up of thousands of tiny, plastic resin beads (FIG. 5). As hard water passes through the bed, each bead attracts and holds the hardness minerals. This is called ion-exchanging. It is much like a magnet attracting and holding metals. Water without the hardness minerals (soft water) flows out of the softener and into the house soft water pipes. After a period of time, the resin beads hold all of the hardness minerals they can, and cleaning with salt brine is needed. This cleaning is called regeneration or recharge. Regeneration is started at 2:00 a.m. by the electronic timer (see page 2-5). It takes place in 5 stages or cycles. These are:

- | | |
|----------------------|---------------------|
| 1 FILL | 4 BACKWASH |
| 2 BRINING | 5 FAST RINSE |
| 3 BRINE RINSE | |

Note:
If the *Clean* feature is set to ON, additional backwash and fast rinse cycles occur before the fill cycle.

FIG. 5 Water Flow Through the Softener in Service

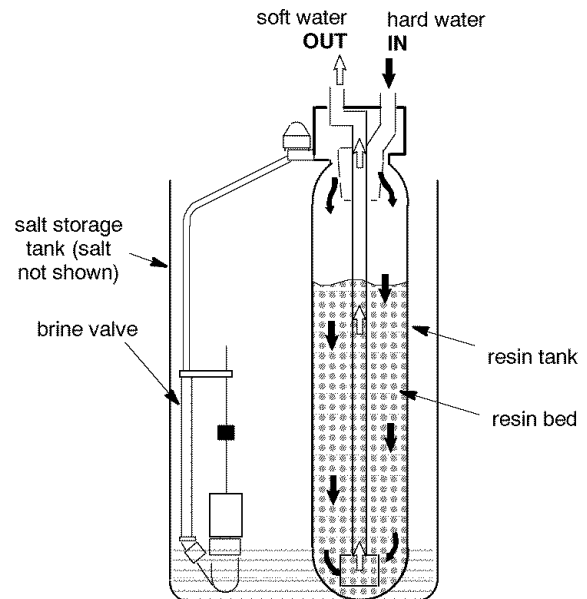

B. SOFT WATER SERVICE and REGENERATION

REGENERATION

1 FILL: Salt, dissolved in water, is called brine. Brine is needed to clean the hardness minerals from the resin beads. To make the brine, water flows into the salt storage area during the fill stage as shown in FIG. 6. Fill cycle length depends on how much soft water making capacity you have used since the last regeneration. As you use more water, fill time increases so more brine is made. The greater amount of brine cleans more hardness minerals from the resin bed.

FIG. 6

Water Flow Through the Softener in Fill

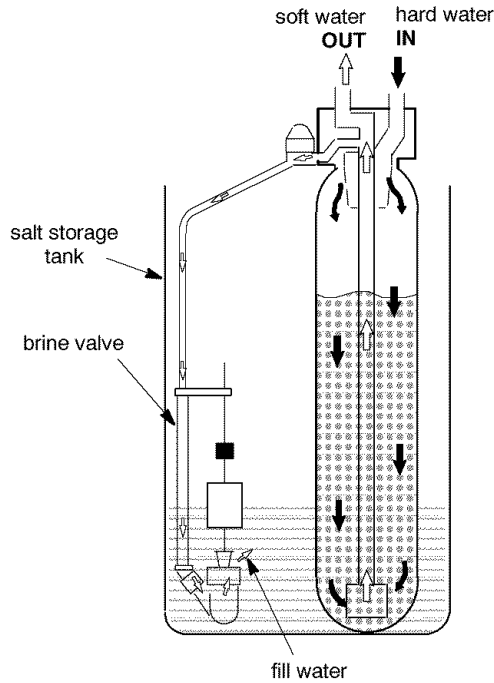

2 BRINING: During brining, the brine is moved from the salt storage area, into the resin tank. Inside the resin tank, brine cleans hardness minerals from the resin beads and they are discharged out the drain. How much brine is needed to clean the resin depends on:

- the hardness of your water,
- the amount of water used during service,
- the amount of resin in the softener,
- how fast the brine goes through the bed.

The nozzle and venturi (FIG. 7) make suction to take brine from the salt tank and put it into the resin tank. They keep the brine flow down to a very slow rate to get the best resin cleaning with the least salt.

3 BRINE RINSE: After all of the brine is moved into the resin tank, the brine valve closes. Water keeps flowing the same way it did during brining except the brine flow has stopped. Hardness minerals and brine flush from the resin tank to the drain. Brining and brine rinse together vary in the length of time they take, relative to the fill cycle length.

FIG. 7

Water Flow Through the Softener in Brining and Brine Rinse

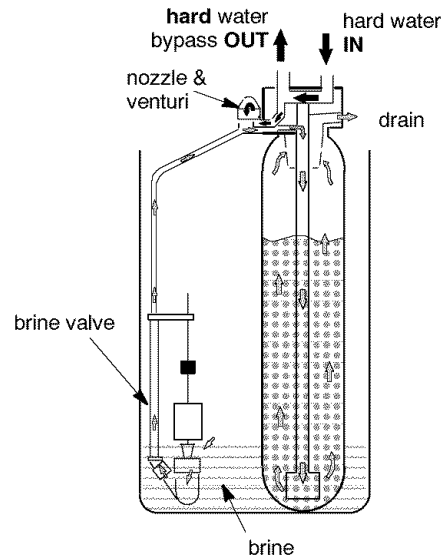

4 BACKWASH: During backwash, water flows UP through the resin tank (FIG. 8) at a fast rate to flush iron minerals, dirt and sediments from the bed and to the drain. The bed lifts and expands for good cleaning.

FIG. 8

Water Flow Through the Softener in Backwash

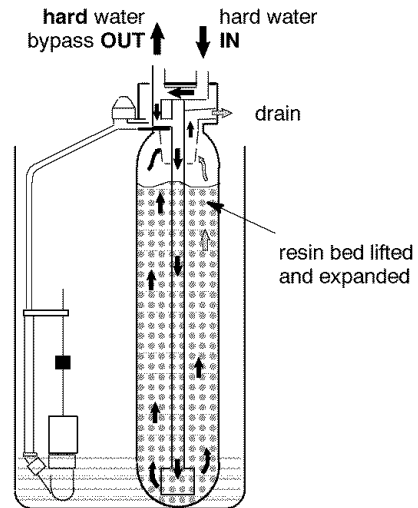

B. SOFT WATER SERVICE and REGENERATION

5 FAST RINSE: Backwash is followed by a fast flow of water down through the resin tank. The fast flow packs the resin bed and gets it ready for return to service (FIG. 9).

After fast rinse, the softener returns to service. Hard water goes into the resin tank where the resin bed again takes out the hardness minerals. Soft water goes to the house soft water pipes.

FIG. 9

Water Flow Through the Softener in Fast Rinse

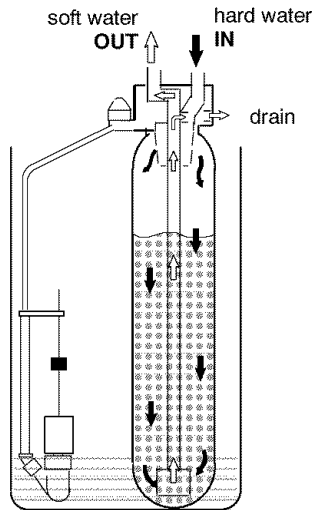

AUTOMATIC BYPASS

During the brining, brine rinse and backwash cycles of regeneration, HARD water goes through the softener valve and to the house pipes. If a faucet is opened, hard water is there for your needs. However, you should not use **hot** water, if possible, because the water heater will refill with hard water. The softener, as factory programmed, regenerates from 2:00 AM to about 4:30 AM, a time when not much water is used.

If you get up early in the morning and you can hear the softener regenerating, change the recharge starting time. Set the recharge time to 12:00 AM or 1:00 AM (page 1-4). Then regeneration will start and end that much earlier and your water heater will not refill with hard water if a hot faucet is opened.

ELECTRONICS

Two main parts of the softener's electronics are ① a WATER METER, and ② a COMPUTER.

① WATER METER — The water meter is in the softener valve outlet. As water flows through the meter, it sends electric pulses to the computer. The computer changes the pulses to measure the volume of water.

② COMPUTER — The computer is part of the faceplate timer circuit board. It is programmed to know the softener's capacity (how many grains of hardness minerals it will take out of the water before a regeneration is needed). When starting the softener, page 1-4, you set it for the grains per gallon (gpg) hardness of the water.

To find a regeneration pattern best for your needs, the computer uses: (1) water usage from the meter, (2) hardness setting, (3) softener capacity, and (4) time since the last regeneration. The computer always adjusts this pattern to your water using habits. It works toward providing you with soft water for the longest time and at the most efficient salt usage.

Softening capacity is used as hard water goes through the softener and hardness minerals are removed. When the computer determines that only enough capacity remains to provide soft water up to the next regeneration starting time (2:00 AM, or as otherwise set) it will schedule a regeneration. When the regeneration begins, *RECHARGE TIME REMAINING displays during the 2-1/2 hour regeneration.

* Note:

If the CLEAN feature is set to ON, a cleaning backwash ("C" is shown in the display, along with the minutes of the clean cycle remaining), precedes the recharge.

SECTION 3

A. SALT: ADDING TO THE STORAGE TANK, SALT BRIDGE

WHEN TO ADD SALT: The Salt Monitor System (see page 2-1) will turn the low salt light *on* to warn you when to refill with salt. Check for a low salt light a few weeks after you install the softener, and every week after that. **Always refill** at about the #2 salt monitor level. At this level, the

tank is about 1/3 full. Never let the softener use all the salt before refilling. Without salt, you will soon have hard water. After filling, reset the Salt Monitor System, page 2-1.

Note:
You will have a loss in softening capacity and may get partly hard water if less than 10 inches (salt monitor level 2) of salt is in the storage tank.

**PLEASE SEE PAGE 1-6 FOR DIRECTIONS ON ADDING SALT.
BE SURE TO RESET THE SALT MONITOR, PAGE 2-2.**

SALT BRIDGE

Sometimes, a hard crust or salt bridge forms in the salt storage tank. It is usually caused by high humidity or the wrong kind of salt. When the salt bridges, an empty space forms between the water and salt. Then salt will not dissolve (melt) in the water to make brine. Without brine, the resin bed does not regenerate and you will have hard water.

If the storage tank is full of salt, it is hard to tell if you have a salt bridge. Salt is loose on top, but the bridge is under it. The following is the best way to check for a salt bridge.

Salt should be loose all the way to the bottom of the tank. Hold a broom handle, or like tool, up to the softener as shown in FIG. 10. Make a pencil mark on the handle, 1" or 2" below the top height of the rim. Then, carefully push it straight down into the salt. If a hard object is felt before the pencil mark gets to the top of the tank, it's most likely a salt bridge. Carefully push into the bridge in a few places to break it. **Do not try to break the salt bridge by pounding on the outside of the salt tank. You may damage it.**

If the wrong kind of salt made the bridge, take it out. Then fill the tank with nugget or pellet salt only.

FIG. 10

Salt Bridge

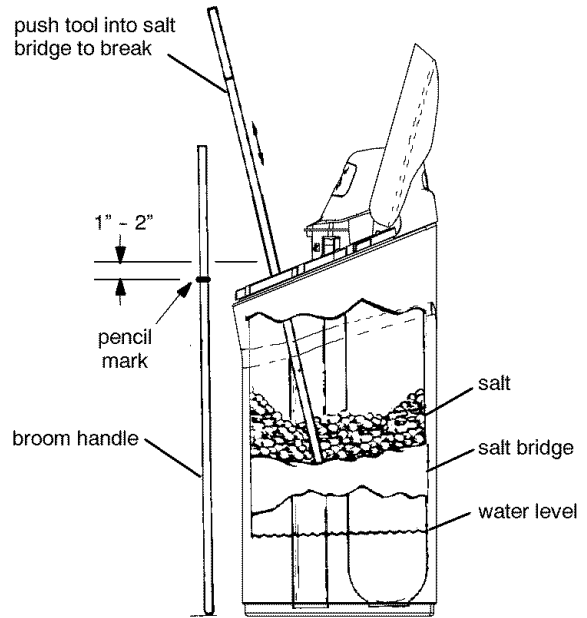

B. KEEPING THE WATER SOFTENER CLEAN

NOZZLE & VENTURI

A clean nozzle and venturi (FIG. 11) is a must for the softener to work right. This small unit moves brine from the salt storage tank to the resin tank during regeneration. If it becomes plugged with sand, silt, dirt, etc., the softener will not work and you will get hard water.

To get to the nozzle and venturi, remove the softener top cover. Be sure the softener is in service cycle (no water pressure at nozzle and venturi), then turn off the cap from the nozzle and venturi housing. *Do not lose the large o-ring seal.* Lift out the screen support and screen, then the nozzle and venturi. Wash and rinse the parts in warm water until clean. If needed, use a small brush to remove iron or dirt. Also check and clean the gasket, flow plugs and screens.

Carefully replace all parts in the correct order. Lubricate the o-ring seal with silicone grease or Vaseline and place in position. Install and tighten the cap, **by hand only**. **Do not overtighten, which may break the cap or housing.**

IRON FROM RESIN BED

Your water softener takes hardness minerals (calcium and magnesium) out of the water. Also, it can control some "clear water" iron. See maximum allowed in the specifications on page 4-1. With clear water iron, water from a faucet is clear when first put into a glass. After 15 to 30 minutes, the water begins to cloud or turn rust colored. A water softener **WILL NOT** remove any iron which makes the water cloudy or rusty as it comes from the faucet (called red water iron). To take red water iron out of water, or over the maximum of clear water iron, an iron fil-

FIG. 11 Cleaning Nozzle & Venturi

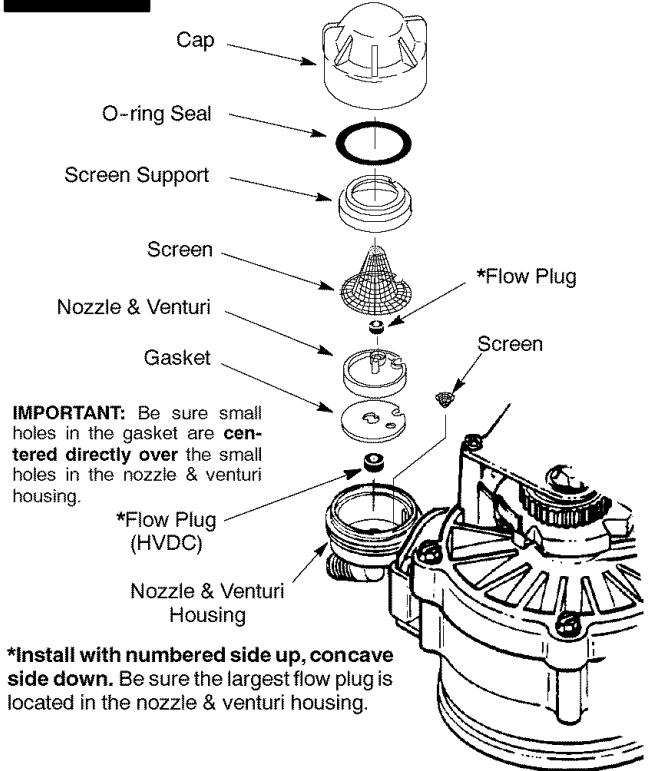

ter or other equipment is needed. Your local Sears store has trained people to help you with iron water problems.

If your water supply has clear water iron, even though less than the maximum allowed, regular resin bed cleaning is needed. Your local Sears store has resin bed cleaner, Item No. 42-34426 for this. Clean the bed at least every 6 months. If iron shows up in the soft water before 6 months, clean more often. Printed instructions are on the resin bed cleaner bottle.

C. PROTECT THE WATER SOFTENER FROM FREEZING

If the softener is installed where it could freeze (summer cabin, lake home, etc.), you must drain all water from it to stop possible freeze damage. To drain the softener:

1. Close the shut-off valve on the house main water pipe, near the water meter or pressure tank.
2. Open a faucet in the soft water pipes to vent pressure in the softener.
3. Refer to FIG. 14 on page 4-1. Move the stem in a single bypass valve to bypass. Close the inlet and outlet valve in a 3-valve bypass system, and open the bypass valve. If you want water in the house pipes again, reopen the shut-off valve on the main water pipe.
4. Unplug the transformer at the wall outlet. Remove the salt hole cover and the main cover. Take off both drain hoses.
5. Carefully remove the large holding clips at the softener inlet and outlet. Separate the softener from the copper tubes, or from the bypass valve.
6. Remove the brinewell cover and disconnect the brine valve tubing at the nozzle and venturi assembly (see page 3-2). Lift the brine valve out of the brinewell. Tip the brine valve upside down to drain water.

FIG. 12 Drain All Water From Softener

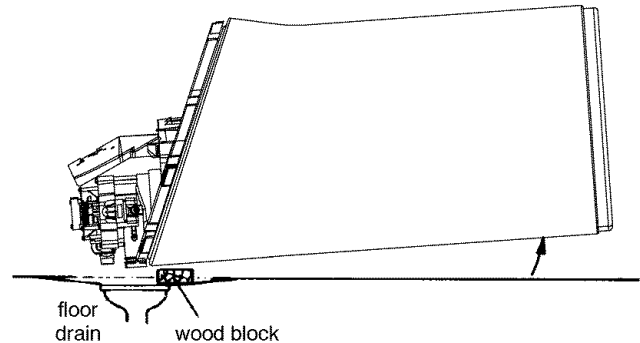

7. Looking at FIG. 12, lay a piece of 2 inch thick board near the floor drain. Move the softener close to the drain. SLOWLY and CAREFULLY, tip it over until the rim rests on the wood block with the inlet and outlet over the drain. **Do not allow the softener's weight to rest on the inlet and outlet fittings or they will break.**
8. Tip the bottom of the softener up a few inches and hold until all water has drained. Leave the softener laying like this until you are ready to use it. Plug the inlet and outlet with rags to keep dirt, bugs, etc. out.

SECTION 3 CARE OF YOUR WATER SOFTENER

D. CHECKLIST ... TO HELP YOU SAVE MONEY

If your water softener fails to work, make the following easy checks. Often, you will find what's wrong yourself and you won't have to call and wait for service. If you do not find anything wrong, while making the checks, and your softener still does not work, call your Sears Service Department.

Note:

1. Also read ERROR CODE, page 5-2.
2. If an error code is **not** displayed, press SELECT button. Move black bar to Service Mode and press SELECT. Then, move black bar to Set Model and press SELECT. The display must show **HF45**. If any other number shows, the face plate computer is working on incorrect input and would probably be the cause of the problem. **To set HF45**, press either the UP \wedge or DOWN \vee button. When HF45 shows, press SELECT *twice* to return to the normal operating screen. *Reset the present time, hardness number, etc., pages 1-3 and 1-4.*

PROBLEM	CAUSE	CORRECTION
<i>No soft water</i>	No salt (or salt bridged) in the storage tank	Add salt, or break the salt bridge (page 3-1). Press ON/OFF-HOLD (RECHARGE NOW) button and hold for 3 seconds to start a regeneration (see page 2-1).
	Transformer unplugged at the wall outlet, or power cable leads loose from the electronic board, fuse blown, circuit breaker popped, or circuit switched off.	Check for loss of power due to any of these and correct. With the power back on, look at the time display and read PROGRAM MEMORY, page 1-4.
	Manual bypass valve(s) in bypass position	Look at FIG. 14 on page 4-1. Move the stem in a single valve to service. In a 3-valve bypass, open the inlet and outlet valves, and be sure to fully close the bypass valve.
	Dirty, plugged or damaged nozzle & venturi	Take apart and clean or replace damaged parts (see page 3-2).
	Valve drain hose plugged or restricted	The drain hose must not have kinks, sharp bends, or be raised too high above the softener (see page 16 in your <i>installation manual</i>).
<i>Water hard sometimes</i>	Hardness number setting too low	Press Select, move the black bar to Settings and press Select again. Move black bar to Hardness, press select. Read the hardness number in the display and be sure the same grains per gallon is shown on your water analysis report. See page 1-4 to reset.
	Using hot water when softener is regenerating	Avoid using hot water during this time because the water heater refills with hard water (see Automatic Bypass, page 2-6).
	Increase in the grains of hardness in your water supply	Ask your Sears retail store for a new water analysis. Then make a new hardness number setting (page 1-4).

A. DIMENSIONS / SPECIFICATIONS

SECTION 4

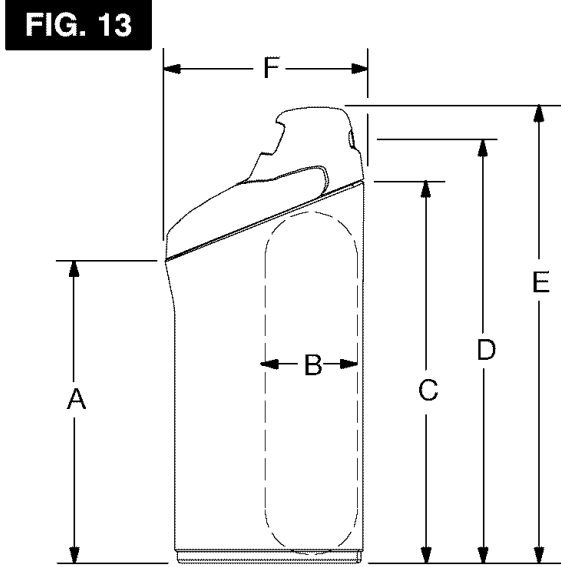

		Inches	CM
A	Salt Tank Height	34	86.4
B	Resin Tank Diameter (nominal)	10	25.4
C	Resin Tank Height (nominal)	40	101.6
D	Inlet-Outlet Height	41-1/2	105.4
E	Overall Height	48	121.9
F ¹	Length	21	53.3
F ²	Width	17	43.2
—	Distance between inlet-outlet center lines	3-7/8	9.8

FIG. 14 BYPASS VALVES

Bypass valve(s) should always remain in soft water service position. Position in "bypass" only if needed for softener repairs.

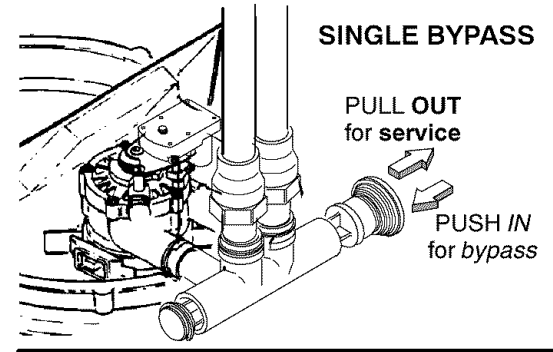

3 - VALVE BYPASS

FOR SERVICE
close bypass valve
open inlet & outlet valves

FOR BYPASS
open bypass valve
close inlet & outlet valves

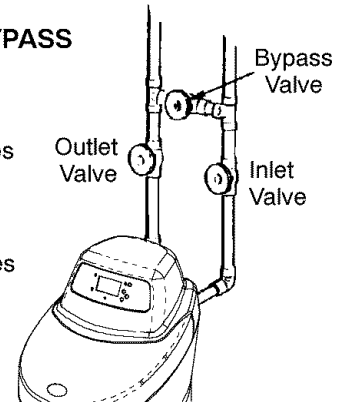

MODEL NOS. 625.388800 & 625.388880

TIMER HF CODE HF45

WATER SUPPLY TO WATER SOFTENER	
Minimum water system flow (gpm)	3
Minimum-Max. water pressure (psi)	20 - 125
Minimum-Max. water temperature (°F)	40 - 120
Maximum water hardness (gpg)	160
Maximum "clear water" iron (ppm) *	12
SALT FOR WATER SOFTENER	
Type of salt needed	nugget or pellet
Alternate type of salt	pure, evaporated, compacted water softener salt

gpm = gallons per minute
psi = pounds per square inch

gpg = grains per gallon
ppm = parts per million

* Capacity to remove clear water iron is substantiated by WQA test data. State of Wisconsin requires additional treatment if water supply contains greater than 5 ppm clear water iron.

SECTION 4 KNOW ABOUT YOUR WATER SOFTENER

A. DIMENSIONS / SPECIFICATIONS

Pressure Drop (PSI) vs. Flow Rate (GPM)

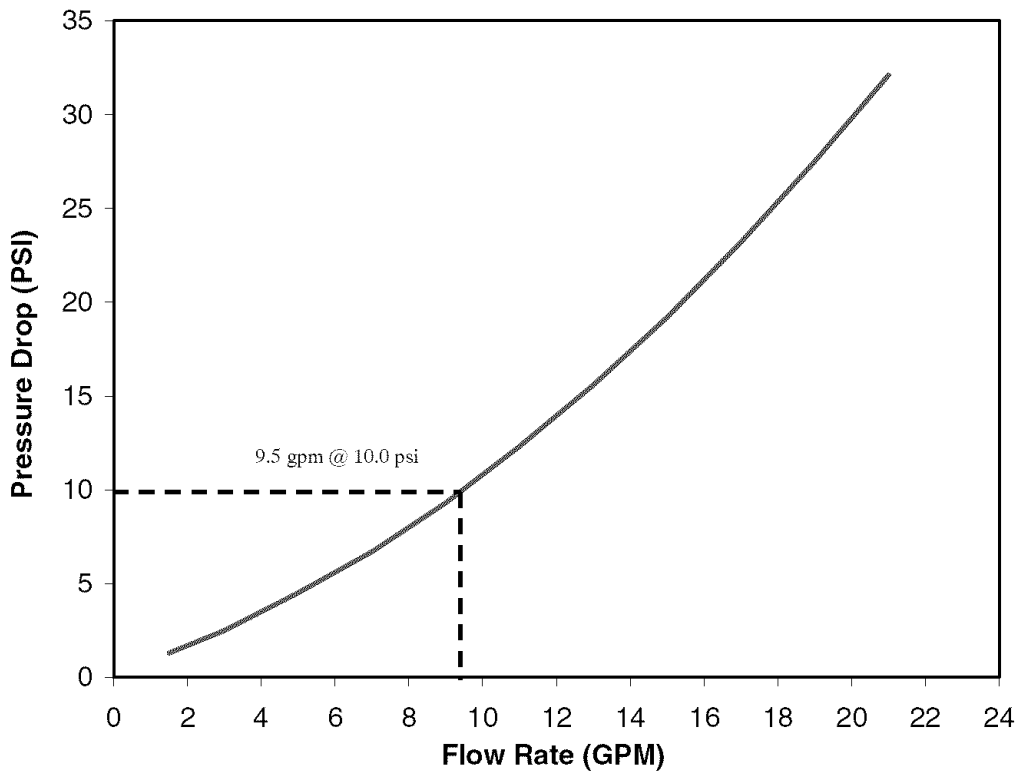

Intermittent flow rate does not represent the maximum service flow rate used for determining the softeners rated capacity and efficiency. Continuous operation at flow rates greater than the service flow rate may affect capacity and efficiency performance.

OTHER SPECIFICATIONS	
Type of ion exchange material (resin)	high capacity
Amount of resin (cu ft)	1.25
Rated Softening Capacity (Grains @ Pounds Salt Dose)	13,300 @ 2.6 35,500 @ 9.8 45,100 @ 17.0
Efficiency Rating (Grains / Pound of Salt @ Minimum Salt Dose)	5120 @ 2.6
Rated Service Flow Rate (gpm)	9.5
Pressure Drop at Rated Service Flow Rate (psi)	10
Max. Drain Flow Rate (gpm)	2.0

This system conforms to NSF/ANSI 44 for the specific performance claims as verified and substantiated by test data.

The efficiency rating is only valid at the minimum stated salt dose. This softener was efficiency rated according to NSF/ANSI Standard 44.

A. TROUBLESHOOTING

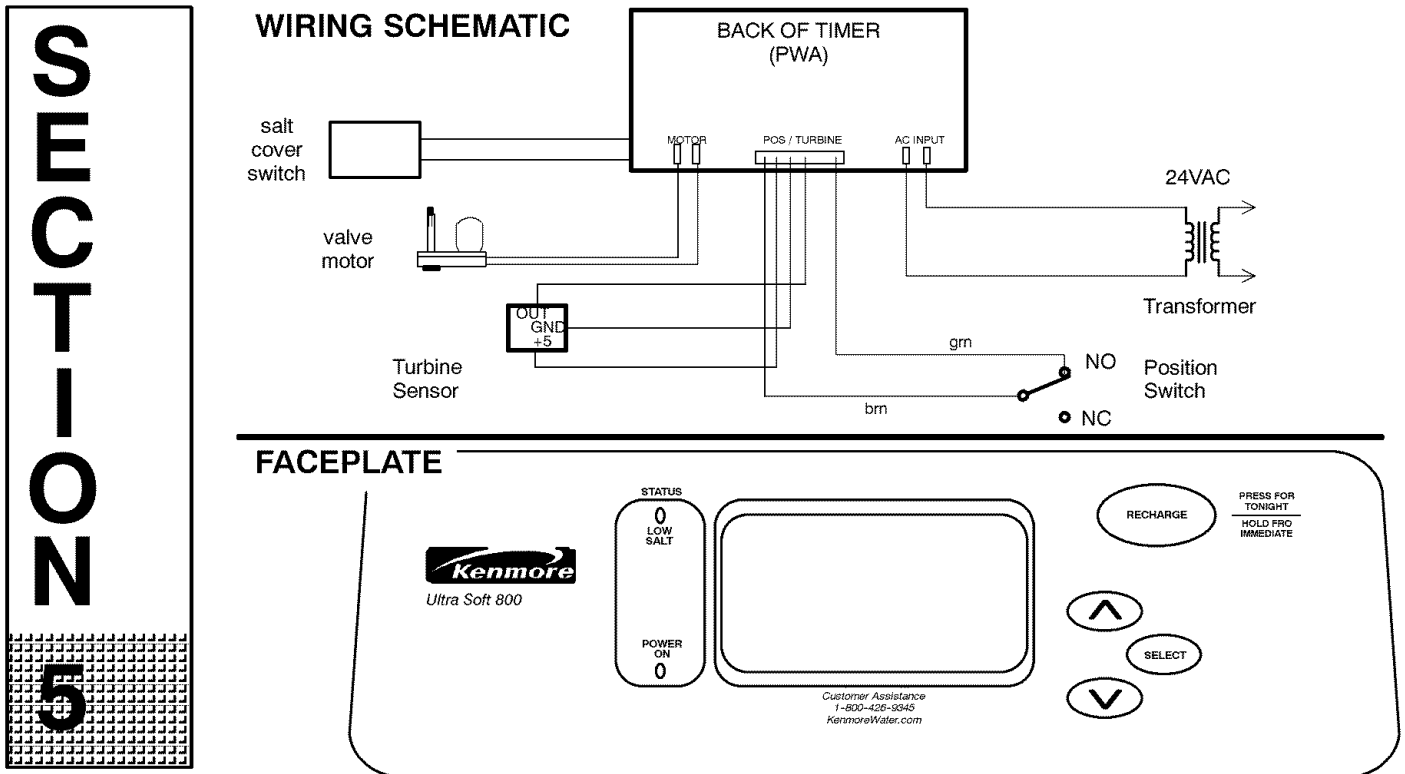

Keep this manual with your water softener. If repairs are needed, the service technician must have the information on the following 8 pages. For telephone assistance, call toll free, 1-800-426-9345.

ALWAYS MAKE THESE INITIAL CHECKS FIRST

1. Does the time display show the correct time of day?
 - If display is blank, check power source to the softener.
 - If Set Time is displayed, power was off for over 68 hours. The softener resumes normal operation but regenerations may occur at the wrong time.
 - If an error code (Example: Error #3) shows in the faceplate display, go to *AUTOMATIC ELECTRONIC DIAGNOSTICS*. (See page 5-2).
2. Plumbing bypass valve(s) must be **fully in service position**.
3. The inlet and outlet pipes must connect to the softener inlet and outlet respectively.
4. Is the transformer plugged into a "live", grounded wall outlet, and the power cable fastened securely to the controller?

5. The valve drain hose must be free of kinks and sharp bends, and not elevated over 8 ft. above the floor.

Remove the top cover and salt tank cover.

6. Is there salt in the storage tank?
7. Is the brine tubing connected? (See water flow diagrams).
8. Is the brine valve float set right? (See page 5-4).
9. Press the SELECT button two times to display Settings menu. Move black bar to Hardness and press Select. Be sure it is the correct setting for the household's water supply. (Make a hardness test of the raw water and compare with the hardness setting. Also test a soft water sample to verify if a problem exists.) Press the SELECT button twice more to return to normal operating display.

If you do not find the problem after making initial checks, do the *MANUAL INITIATED ELECTRONIC DIAGNOSTICS*, and the *MANUAL ADVANCE REGENERATION CHECK*.

A. TROUBLESHOOTING

AUTOMATIC ELECTRONIC DIAGNOSTICS

The faceplate timer (PWA) computer has a self-diagnostic function for the electrical system, except for input power and water meter. The computer monitors electronic components and circuits for correct operation. If a malfunction occurs, an error code appears in the faceplate display.

Error #1
Service Required See Owners Manual
Diagnostics

The chart below shows the error codes that could appear, and the possible defects for each code.

While an error code appears in the display, all faceplate buttons are inoperable except the SELECT button. SELECT remains operational so the service person can make the MANUAL INITIATED ELECTRONIC DIAGNOSTICS (below) to further isolate the defect, and check the water meter.



CODE	POSSIBLE DEFECT	
	MOST LIKELY ←	→ LESS LIKELY
Error #1, Error #3, Error #4	motor inoperative / wiring harness or connection to switch / position switch / valve defect causing high torque	
Error #5	faceplate timer (PWA)	

PROCEDURE FOR REMOVING ERROR CODE FROM FACEPLATE: 1. Unplug transformer from outlet 2. Correct defect 3. Plug in transformer 4. Wait for 8 minutes. The error code will return if the defect was not corrected.

MANUAL INITIATED ELECTRONICS DIAGNOSTICS

- To enter diagnostics, press the SELECT button once to go to the Main Menu. Move the black bar to Service Mode and press Select. Move black bar to Diagnostics and press Select.



You will see the following display, showing valve cycle position, position switch status (open or closed), and turbine operation.

valve position indicator	
10:39:56 AM Pos: SERVICE 0:00 Req Pos: SERVICE Motor: Off  Trbn: 000 Gals: 0 Days: 1 Rchgs: 0 Last Rchg: 4	10:39:56 AM Pos: SERVICE 0:00 Req Pos: SERVICE Motor: Off  Trbn: 126 Gals: 0 Days: 1 Rchgs: 0 Last Rchg: 4
turbine count (no water flowing)	turbine count (water flowing)
	position switch indicator (open)

TURBINE OPERATION: If no water is flowing through the softener, the turbine indicator displays 3 zeros. When water is flowing, a 000 to 140 count repeats for each gallon of water passing through the turbine. To check for positive operation of the turbine if zeros are shown, open a nearby soft water faucet and observe the turbine count.

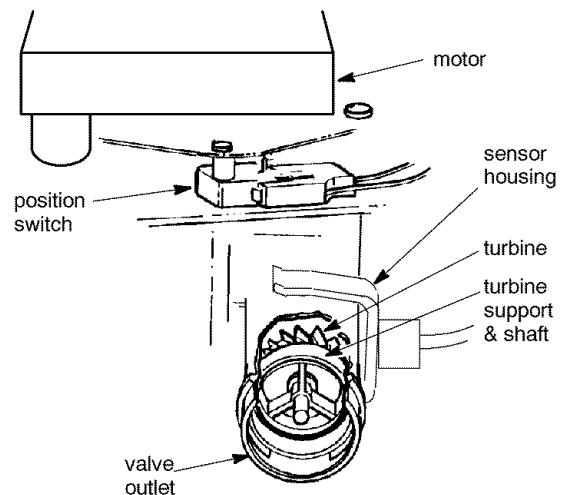
If you don't get a reading in the display, with faucet open, pull the sensor from the valve outlet port. Pass a small magnet back and forth in front of the sensor. You should get a reading in the display. If you get a reading, unhook the in and out plumbing and check the turbine for binding.



POSITION SWITCH STATUS: With the valve in service, or any of the recharge cycles, the switch indicator will show open . While the valve is rotating from one position to another, the indicator will show the switch closed . A defect is probable if indications vary from this pattern.

A. TROUBLESHOOTING

NOTE: If the faceplate is left in a diagnostic display (or other displays when setting times or hardness), normal operating screen automatically returns if a button is not pressed within 4 minutes. To return to the diagnostic display, repeat step 1.

2. Press the RECHARGE button to advance the valve to each position and observe the switch and position indicators to verify component operation, or to possibly isolate a defect.
3. Press Select once to move back to the Service Mode screen. Move black bar to Set Model and press Select. Verify the model code.

...HF45 shows.

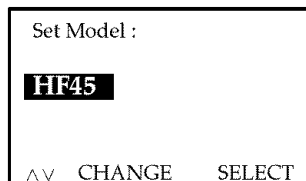

This code identifies the softener nominal capacity size. If the wrong number shows, the softener will operate on incorrect programming. Do the following as needed.

HF45 does show — Press the SELECT button to normal operating display.

To change HF number — Press the UP or DOWN button until HF45 shows. Then, press the SELECT button and reset the timer...page 1-3.

TIMER PWA REPLACEMENT: Be sure the valve is in service position when replacing the timer PWA (observe valve cycle indicator).

If, after installing and programming the replacement timer PWA, the valve is not in service position, do the following to assure correct cycle orientation, or timing, between the faceplate and valve.

Use the MANUAL ADVANCE procedures, page 5-4. With the RECHARGE NOW button, advance through the recharge cycles until the valve stops in service position.

NOTE: The valve motor may automatically drive through several valve positions while searching for service. If an error code occurs, unplug the transformer, then plug in again.

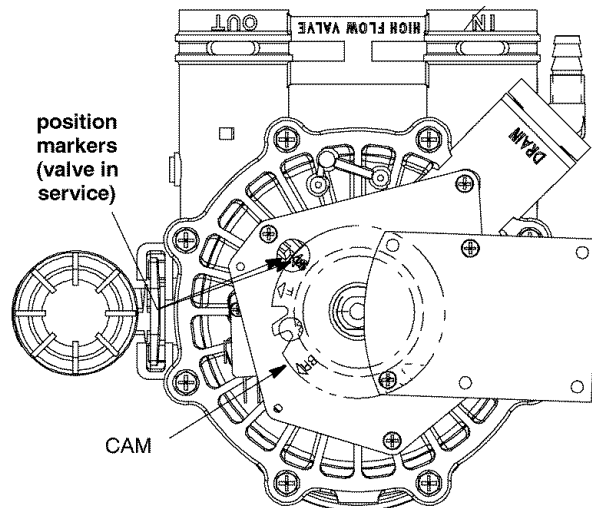

A. TROUBLESHOOTING

MANUAL ADVANCE REGENERATION CHECK

This check verifies proper operation of the valve motor, brine tank fill, brine draw, regeneration flow rates, and other controller functions. **Always make the initial checks, and the manual initiated diagnostics.**

Note: The faceplate display must show normal operating screen. If an error code shows, first press the SELECT button to enter the diagnostic display.

1. Press the RECHARGE button and hold in for 3 seconds. The Recharge display shows as the softener enters the fill cycle of regeneration. When FILL time begins to count down, remove the brinewell cover and, using a flashlight, observe fill water entering the tank.

*Note: If the CLEAN feature is set to ON, the clean icon flashes while the backwash or fast rinse cycles are in progress, along with the minutes remaining in each cycle. This proceeds the normal regeneration cycle.

- a. If water **does not** enter the tank, look for an obstructed nozzle, venturi, fill flow plug, brine tubing, or brine valve riser pipe.

CYCLE FLOW RATES (GALLONS PER MIN.)	
FILL (flow to salt storage tank)	0.3 (1.1 liters)
BRINING	.22 (.83 liters)
BRINE RINSE	.15 (.57 liters)
BACKWASH	2.0 (7.6 liters)
FAST RINSE	2.0 (7.6 liters)

(flow to drain)

2. After observing fill, press the RECHARGE button to move the softener into brining. A slow flow of water to the drain will begin. Verify brine draw from the brine tank by shining a flashlight into the brinewell and observing a noticeable drop in the liquid level.

Note:

Be sure a salt bridge is not preventing water with salt contact.

- a. If the softener does not draw brine...
 - ...nozzle and/or venturi dirty or defective.
 - ...nozzle and venturi not seated properly on gasket.
 - ...restricted drain (check drain fitting and hose).
 - ...defective nozzle and venturi seal.
 - ...other inner valve defect (rotor seal, rotor & disc, wave washer, etc.).

Note:

If water system pressure is low, an elevated drain hose may cause back pressure, stopping brine draw.

3. Again press RECHARGE to move the softener into backwash. Look for a fast flow of water from the drain hose.
 - a. An obstructed flow indicates a plugged top distributor, backwash flow plug, or drain hose.
4. Press RECHARGE to move the softener into fast rinse. Again look for a fast drain flow. Allow the softener to rinse for a few minutes to flush out any brine that may remain in the resin tank from the brining cycle test.
5. To return the softener to service, press RECHARGE.

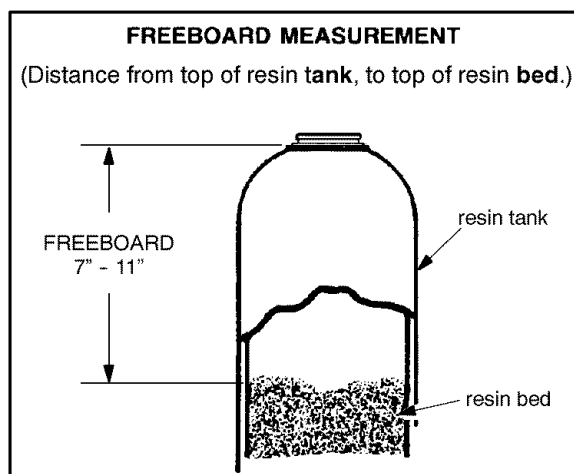
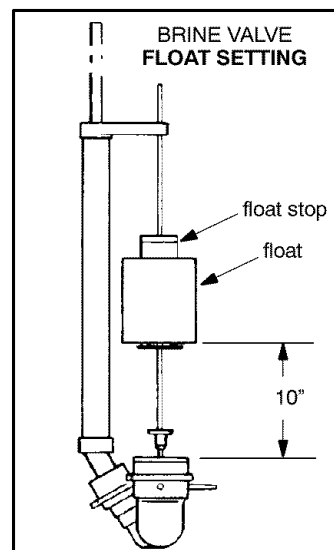

B. ROTARY VALVE SERVICE

Before working on the valve, **turn off the water supply and disconnect from electrical power. TO RELIEVE PRESSURE:**

- **3 VALVE BYPASS:** Close the inlet valve and open a soft water faucet. Then close the outlet valve and open the bypass valve.
- **SEARS SPECIAL BYPASS:** Slide the bypass valve stem to bypass position. *Loosen* three hex head screws toward the back side of the valve to allow pressure water to bleed out. Catch water with a rag.

DISASSEMBLY

To remove a part or group of parts, refer to the valve drawing. A common screwdriver or nut driver, Phillips screwdriver and pliers are the only tools needed to completely disassemble.

SERVICING THE VALVE

Inspect all o-rings, seals and gaskets for wear or defects.

Inspect the bottom surface of the rotor for scratches, chips or wear.

Note:

If replacement is needed, be sure to use the current replacement part.

ASSEMBLY

Be sure all parts are in place and in the proper position. Lubricate ALL o-rings and seals with FDA approved silicone grease. To install the rotor seal, first place the seal into the valve groove, rounded side down (see cross-section). Apply a light coating of silicone grease to the seal's crossing ribs. Then, carefully center the wear strip on the seal, and push it downward onto the seal.

Install the nozzle and venturi seal and drain seal. Assemble wave washer bearing, the wave washer, and two o-rings onto the rotor top shaft. Then center the rotor in the valve body, on the rotor seal.

Lower the cover onto the valve body and rotor shaft. Then install the cover holding screws. **Before tightening the screws**, install the valve cam and gear. Then, turn the rotor (clockwise only) to service position. Tighten the valve assembly screws using a

criss-cross pattern. If a torque wrench is available, torque to 30-40 inch pounds.

Install bearing onto gear shaft. Install motor plate and tighten screws to a snug fit. See page 6-5 for detailed schematic.

Lubricate the gear on the motor, and the valve cam gear with Molykote grease, or other high quality gear lubricant.

Be sure to orient switch as shown, with lever toward the cam.

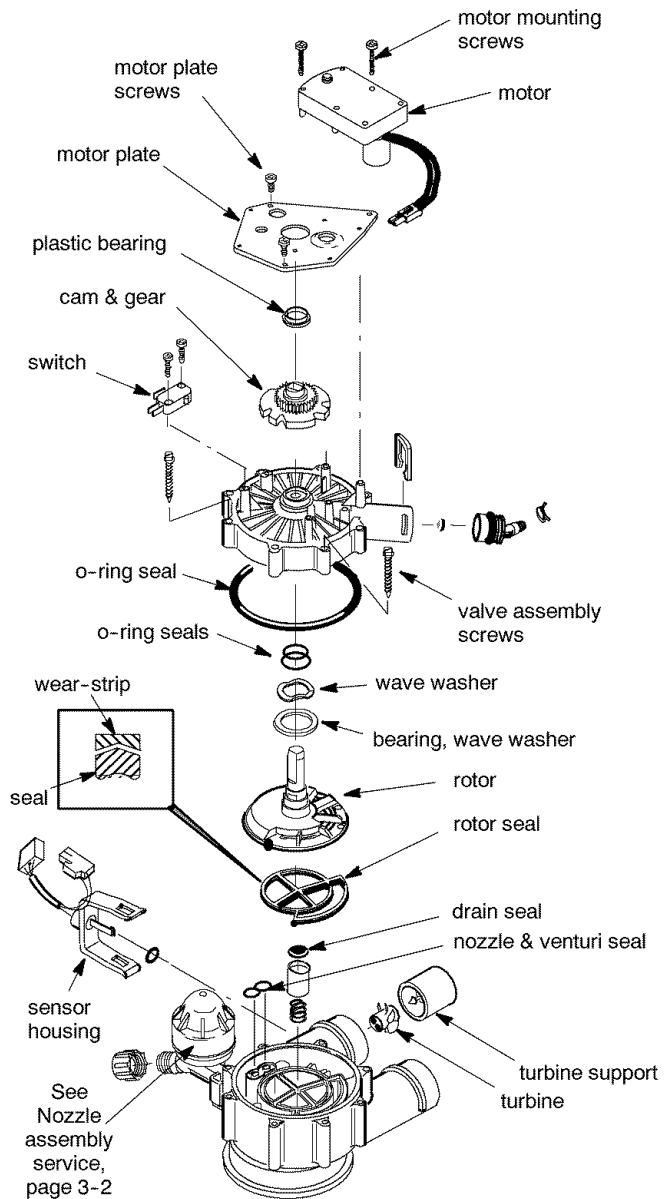

C. WATER FLOW THROUGH THE SOFTENER VALVE

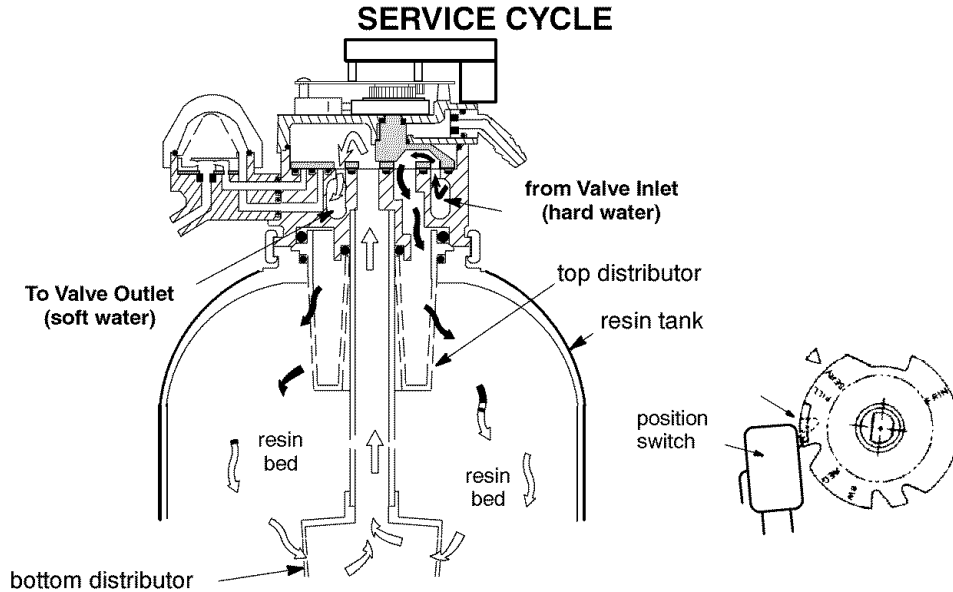

Hard water enters the valve inlet port. Internal valve porting routes the water down and out the top distributor, into the resin tank. Hard water is softened as it passes through the resin bed, then enters the bottom distributor. Soft water flows back into the valve and out the valve outlet, to the house soft water pipes.

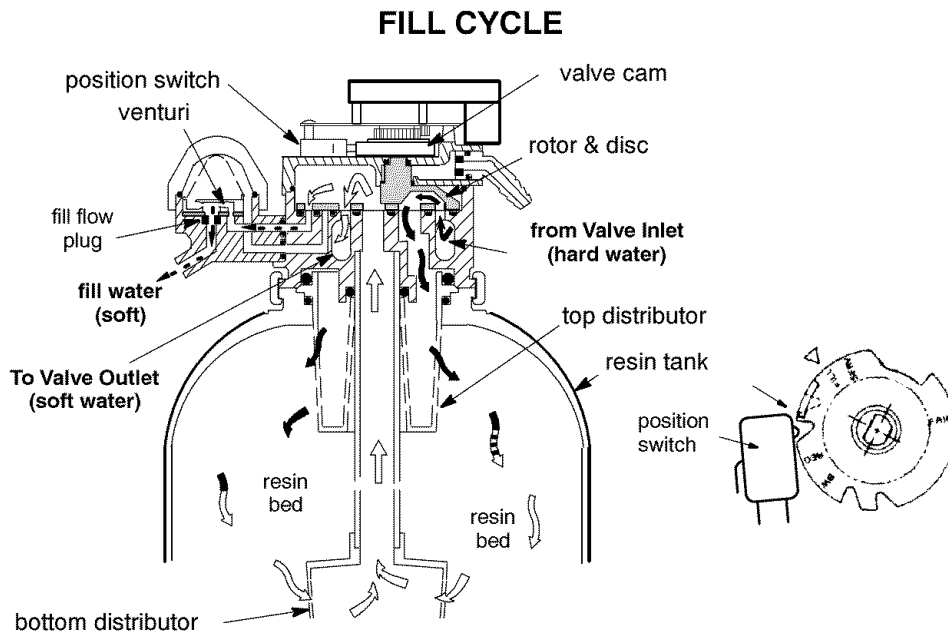

To begin a regeneration, the electronic timer energizes the circuit to the valve motor. The valve motor rotates the rotor and disc and the valve cam until the position switch drops, to open the motor circuit and position the valve in FILL. As the rotor and disc rotates, the port opens for SOFT water fill through the venturi. Fill flow continues to the brine valve, and into the salt storage tank. Soft water is still available to the house lines.

C. WATER FLOW THROUGH THE SOFTENER VALVE

BRINING AND BRINE RINSE CYCLES

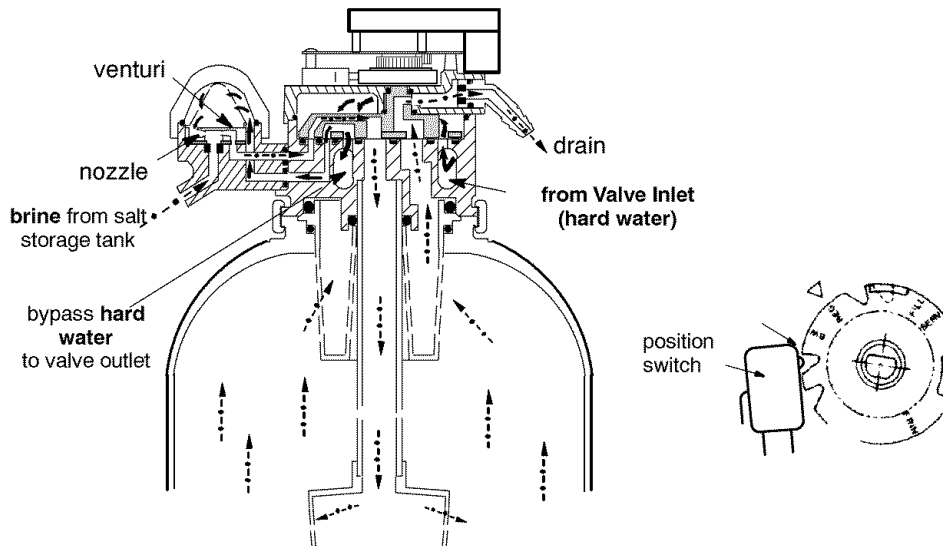

After fill, timer/switch action allows the motor to turn the rotor and disc into BRINING position. Water flow is directed to the nozzle. Suction, created by the nozzle and venturi, draws brine from the salt storage tank and injects it into the resin bed via the bottom distributor. Flow continues out the top distributor and to the drain. Hard water is available at the valve outlet.

When the brine valve closes to end brine draw, water flow continues in the same directions to slowly RINSE brine from the resin bed and to the drain.

BACKWASH CYCLE

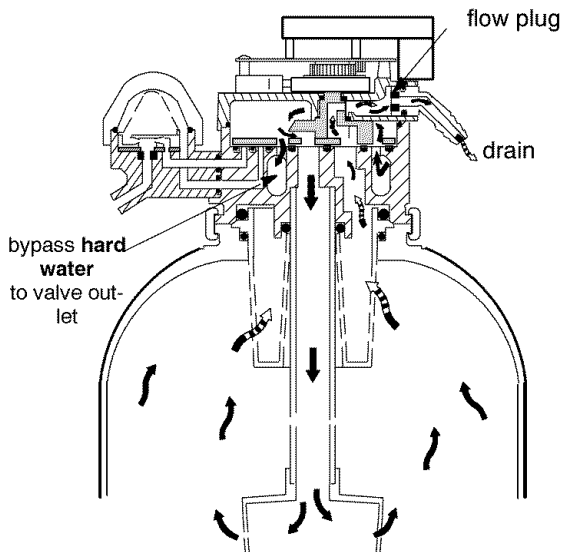

Timer/switch action again allows the motor to turn the rotor & disc to place the valve in BACKWASH, stopping water flow to the nozzle. Water is routed down and out the bottom distributor, up through the bed, and out the top distributor to the drain. The fast flow (controlled by a flow plug in the drain fitting) flushes dirt, sediments, iron deposits, remaining brine and hardness to the drain.

C. WATER FLOW THROUGH THE SOFTENER VALVE

FAST RINSE CYCLE

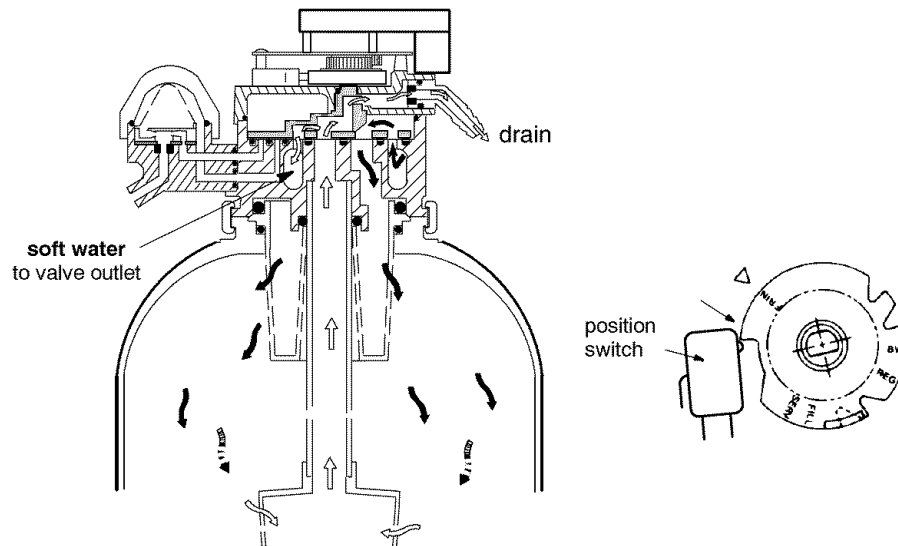

During FAST RINSE, the rotor & disc is positioned so water flow enters the resin tank through the top distributor, and exits through the bottom distributor, to the drain.

The electronic timer again energizes the motor to return the valve to *service*. As the valve rotates, the position switch drops to open the circuit. The valve remains positioned in service until the electronic timer initiates the next regeneration.

SECTION 6 REPAIR PARTS FOR WATER SOFTENER

Kenmore MODEL NOS. 625.388800 & 625.388880

SECTION 6

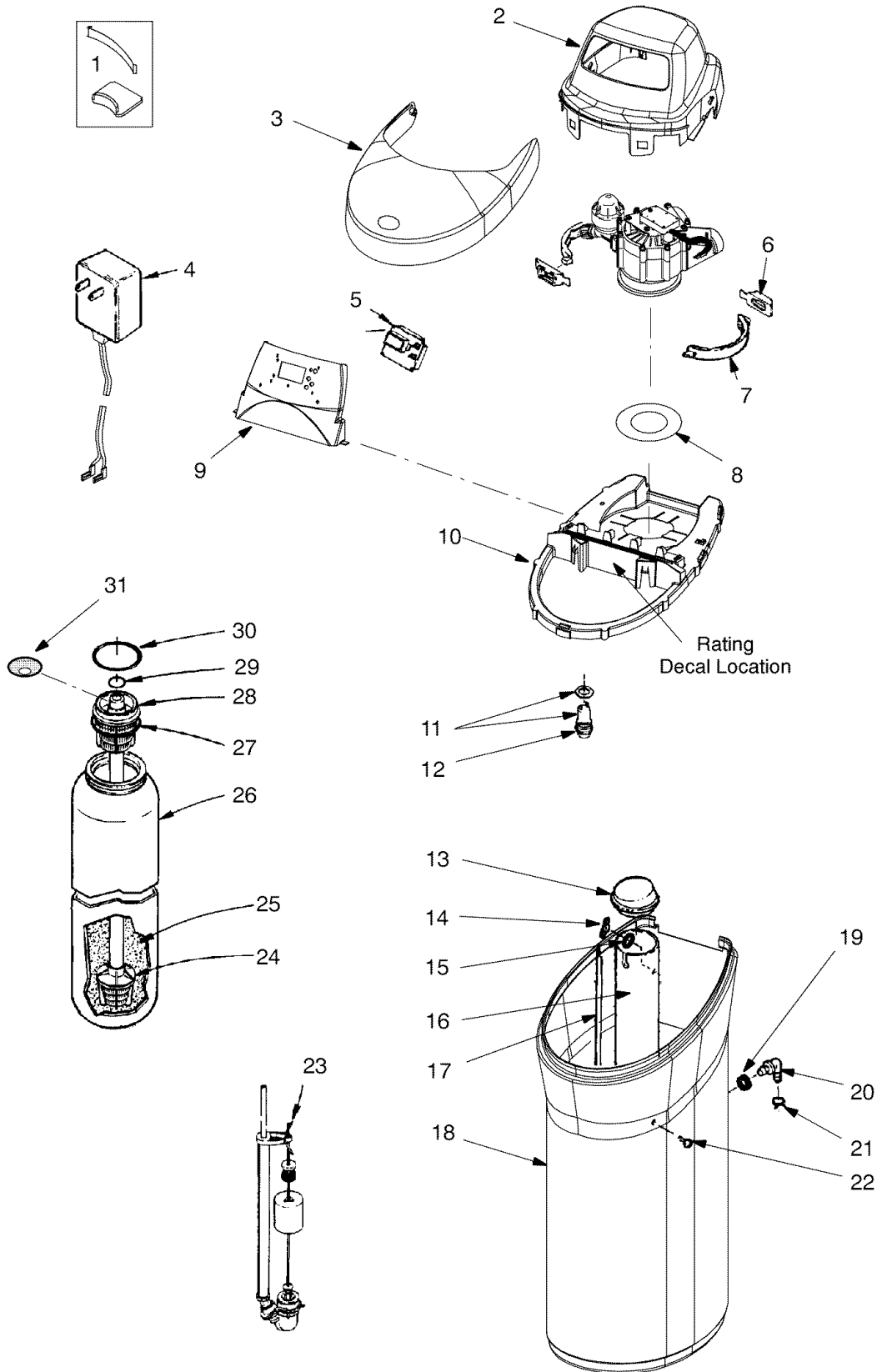

SECTION 6 REPAIR PARTS FOR WATER SOFTENER

Kenmore MODEL NOS. 625.388800 & 625.388880

WATER SOFTENER COMPLETE

KEY NO.	PART NUMBER	DESCRIPTION
1	---	Cover Lock (req'd for ship. only)
1	---	Rim Insert (req'd for shipping only)
2	7229948	Cover (main)
3	7233159	Salt Hole Cover (order following decals)
-	7264582	Instruction Decal
-	7234545	Salt Hole Cover Decal, UltraSoft 800
-	7264825	Salt Hole Cover Decal, UltraSoft 880
4	7252373	Transformer, 24V-10VA ●
5	7234765	Timer Repl. (PWA)
6	7088033	Clamp Retainer (2 req.)
7	7176292	Clamp Section (2 req.)
8	7232446	Vapor Barrier
9	7229956	Faceplate (order following decal)
-	7268104	Faceplate Decal, UltraSoft 800
-	7264469	Faceplate Decal, UltraSoft 880
10	7232276	Rim (incl. Key No. 11 & 12)
11	7137939	Light Asm
12	7252268	O-Ring
13	7219888	Brinewell Cover
14	7082150	Wing Nut, 1/4"
15	7003847	O-Ring
16	7109871	Brinewell
17	7214236	Decal, Salt Level ①
18	7234773	Salt Storage Tank

KEY NO.	PART NUMBER	DESCRIPTION
19	9003500	Grommet ●
20	1103200	Tube Adaptor ●
21	0900431	Tube Clamp ●
22	7232250	Plastic Screw, 1/4" x 5/8"
23	7116488	Brine Valve Assem. (also see page 6-2)
24	7105047	Replacement Distributor
25	0502272	Resin
26	7235478	Resin Tank (includes Key No. 25)
27	7170270	O-Ring, 2-3/4" x 3"
28	7077870	Top Distributor
29	7170254	O-Ring, 13/16" x 1-1/16"
30	7170296	O-Ring, 2-7/8" x 3-1/4"
31	7265025	Ultra Cleansing Screen, UltraSoft 880 only
◆	3442699	Resin Bed Cleaner
◆	7195995	Parts Bag, (includes parts marked with a ●, pages 6-2, 6-4 & 6-6) - order manuals separately if necessary
◆	7258997	Installation Manual
◆	7276563	Owners Manual

◆ not illustrated

① aligns with top of brinewell

● included in parts bag

SECTION 6 REPAIR PARTS FOR WATER SOFTENER

Kenmore MODEL NOS. 625.388800 & 625.388880

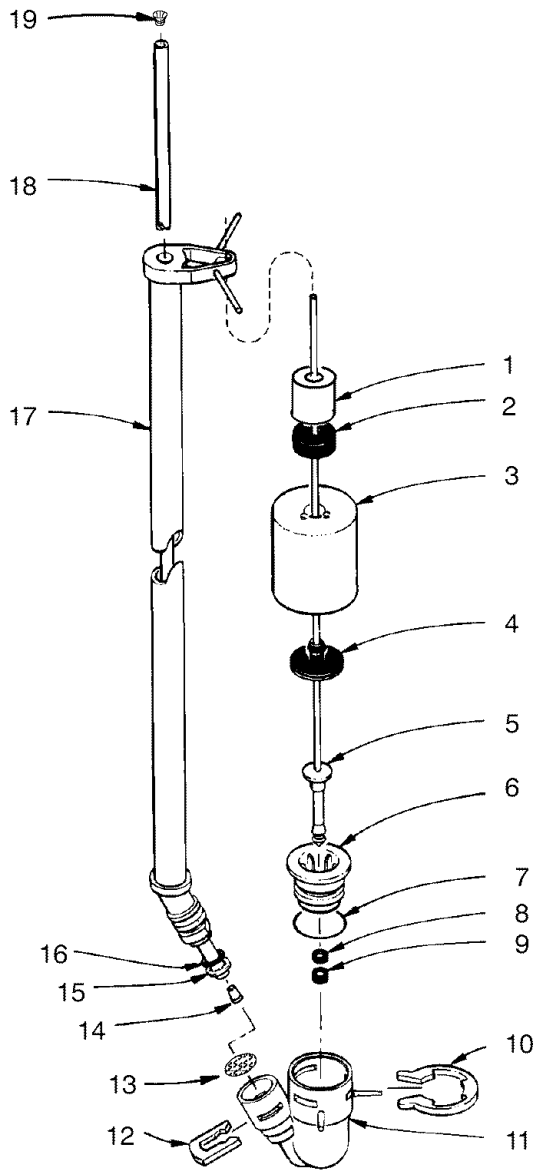

**INLET - OUTLET
GROUNDING CLAMPS**

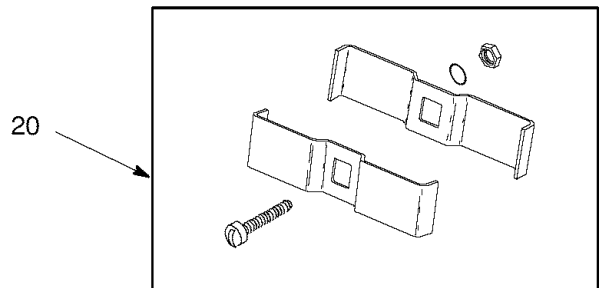

SECTION 6 REPAIR PARTS FOR WATER SOFTENER**Kenmore MODEL NOS. 625.388800 & 625.388880**

KEY NO.	PART NUMBER	DESCRIPTION
1	7168647	Ceramic Weight
2	0513860	Float Stop
3	7097202	Float (includes Key No. 4)
4	0516947	Float Seal
5	7093216	Float Rod & Stem
6	7092278	Guide Cap
7	7170288	O-Ring 15/16 x 1-3/16
8	0516211	Seal
9	0516924	Retainer, Bottom Seal
10	7116713	Clip
11	7092252	Brine Valve Body
12	1205500	Clip
13	7131365	Screen
14	7094979	Insert
15	7092294	Retaining Ring
16	7176161	O-Ring, 5/16 x 9/16
17	7095470	Brine Tube
18	7113016	Tubing Assy. (includes Key Nos. 14, 15 & 16)
19	7171349	Cone Screen
20	7248706	Grounding Clamp Kit ●

● included in parts bag, page 6-2

VALVE ASSEMBLY

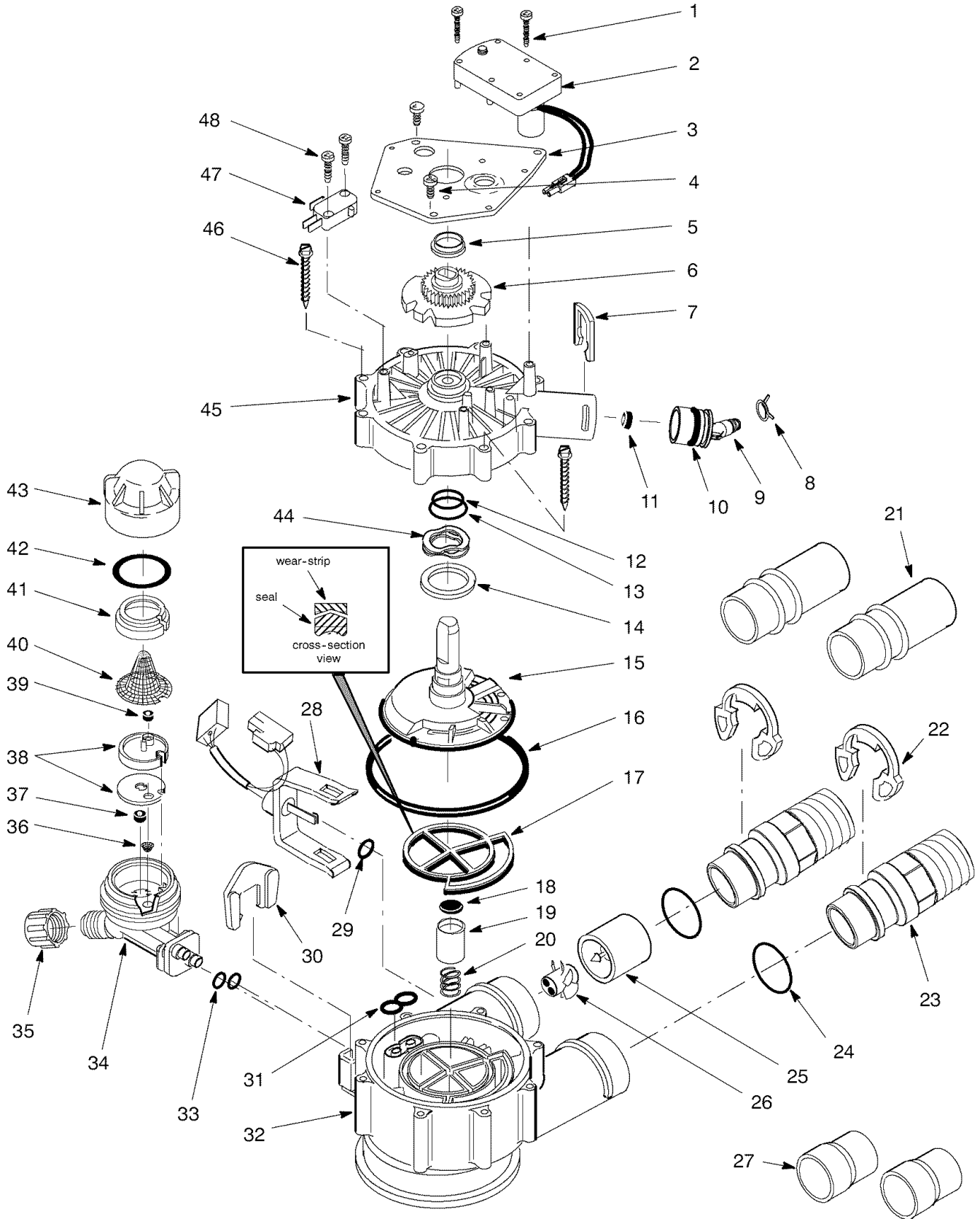

SECTION 6 REPAIR PARTS FOR WATER SOFTENER

Kenmore MODEL NOS. 625.388800 & 625.388880

VALVE ASSEMBLY

KEY NO.	PART NUMBER	DESCRIPTION
1	7224087	Screw, #8-32 x 1" (2 req.)
2	7228544	Motor (incl. 2 ea. of Key No. 1)
3	7231393	Motor Plate
4	0900857	Screw, #6-20 x 3/8 (3 req.)
5	7171250	Bearing
6	7219545	Cam and Gear
7	7169180	Clip (Drain)
8	0900431	Hose Clamp
9	7271270	Drain Hose Adaptor
10	7170288	O-ring, 15/16 x 1-3/16
11	0501228	Flow Plug #18
12	7170327	O-ring, 5/8 x 13/16
13	7173024	O-ring, 1-1/8 x 1-1/2
14	7174313	Bearing, Wave Washer
15	7185500	Rotor & Disc
16	7173032	O-ring, 4-1/2 x 4-7/8
17	7185495	Rotor Seal
18	7172989	Seal
19	7171187	Plug (Drain Seal)
20	7129889	Spring
21	7077642	Copper Tube, 1" (2 req.) ■
22	7089306	Clip (2 req.) ●
23	7271204	Installation Adaptor, 1" NPT (2 req.) ●
24	7170262	O-ring, 1-1/8 x 1-3/8 (4 req.) ●
25	7094898	Turbine Support
26	7101548	Turbine
27	7232234	Reducer, 1" to 3/4" (2 req.) ② ●
28	7248722	Wire Harness (Sensor)
29	0900060	O-ring

KEY NO.	PART NUMBER	DESCRIPTION
30	7081201	Retainer (Nozzle & Venturi)
31	7195482	Seal (Nozzle & Venturi)
32	7171145	Valve Body
33	7170319	O-ring, 1/4 x 3/8 (2 req.)
34	7081104	Nozzle & Venturi Housing
35	1202600	Nut - Ferrule
36	7095030	Cone Screen
37	1148800	Flow Plug, .3 gpm
38	7114533	Nozzle and Venturi - Gasket Kit
-	7204362	Gasket only
39	7084607	Flow Plug, .15 gpm
40	7146043	Screen
41	7167659	Screen Support
42	7170262	O-ring, 1-1/8 x 1-3/8
43	7199729	Cap
44	7175199	Wave Washer
45	7171161	Valve Cover
46	7172997	Screw, #10 x 2-5/8 (8 req.)
47	7145186	Switch
48	7140738	Screw, #4-24 x 3/4 (2 req.)
◆	3479901	Adaptor Kit, 1" to 1-1/4"
◆	7187065	Nozzle & Venturi Assy. (incl. Key Nos. 34, and 36 through 43)
◆	7185487	Seal Kit (incl. Key Nos. 12, 13, 16, 17, 18 and 31)
◆	7139999	Drain Tubing, 3/8" I.D. x 20' ①
◆	42-34403	Flexible Connectors, 1"
◆	7123613	Silicone Grease (for O-rings)

◆ not illustrated

① included with softener

② 2 included – use only for connecting to 3/4" plumbing

● included in parts bag, page 6-2

■ not included (optional)

BYPASS INSTALLATION VALVE

KEY NO.	PART NUMBER	DESCRIPTION
-	7214317	Bypass Valve ● (Includes following parts)
49	7172882	Stem
50	7173016	O-ring, 1.109 I.D. x 1.387 O.D. (4)
51	7214155	Bypass Body
52	7175238	C-ring

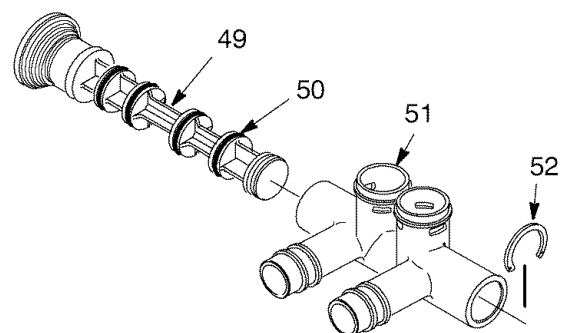

OWNER'S MANUAL

MODEL NOS.

UltraSoft 800
625.388800

UltraSoft 880
625.388880

The model number of your water softener is found on the rating decal. This decal is on the rim, under the salt cover.

When requesting service or ordering parts, always provide the following information:

- ◆ Product Type
- ◆ Model Number
- ◆ Part Number
- ◆ Part Description

www.KenmoreWater.com



Water Softeners

Get it fixed, at your home or ours!

Your Home

For repair – **in your home** – of **all** major brand appliances, lawn and garden equipment, or heating and cooling systems, **no matter who made it, no matter who sold it!**

For the replacement parts, accessories and owner's manuals that you need to do-it-yourself.

For Sears professional installation of home appliances and items like garage door openers and water heaters.

1-800-4-MY-HOME® (1-800-469-4663)

Call anytime, day or night (U.S.A. and Canada)

www.sears.com www.sears.ca

Our Home

For repair of carry-in items like vacuums, lawn equipment, and electronics, call or go on-line for the location of your nearest **Sears Parts & Repair Center.**

1-800-488-1222

Call anytime, day or night (U.S.A. only)

www.sears.com

To purchase a protection agreement (U.S.A.) or maintenance agreement (Canada) on a product serviced by Sears:

1-800-827-6655 (U.S.A.)

1-800-361-6665 (Canada)

Para pedir servicio de reparación a domicilio, y para ordenar piezas:

1-888-SU-HOGARSM
(1-888-784-6427)

Au Canada pour service en français:

1-800-LE-FOYER^{MC}
(1-800-533-6937)
www.sears.ca

® Registered Trademark / TM Trademark / SM Service Mark of Sears, Roebuck and Co.
® Marca Registrada / TM Marca de Fábrica / SM Marca de Servicio de Sears, Roebuck and Co.
^{MC} Marque de commerce / ^{MD} Marque déposée de Sears, Roebuck and Co.

© Sears, Roebuck and Co.

Sears, Roebuck and Co., Hoffman Estates, IL 60179 U.S.A.