

MODEL 5500 13 HP Generator

Item # 56550
Owner's Manual

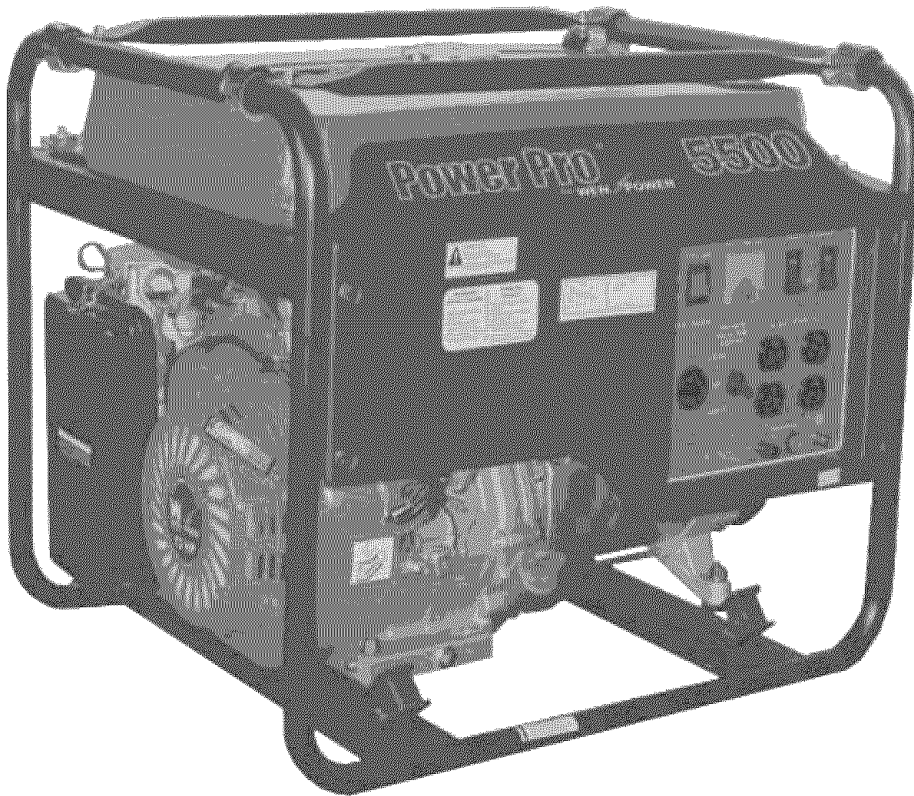

**DO NOT RETURN TO
STORE**

**Questions? Problems?
Please call our customer
help line:**

**(888) 315-3080 M-F 8-5
CT**

Thank you for purchasing a model 5500 generator. This manual provides information regarding the operation and maintenance of this product. We have made every effort to ensure the accuracy of the information in this manual. Wen Power reserves the right to change this product at any time without prior notice.

Please keep this manual available to all users during the entire life of the generator.

rev. 03/24/05

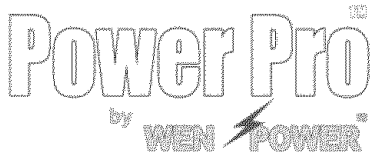

MODEL 5500 13 HP Generator

FEATURES

- *5500 Surge Watt Output*
- *5000 Rated Watt Output*
- *Powerful Enough to Run Essential Appliances During Power Outages*
- *120 and 240 Volt AC Outputs*
- *DC Output for Automotive Battery Charging*
- *Low Oil Automatic Shutoff*
- *Circuit Breaker for Overload Protection*
- *6.5 Gallon Fuel Tank Capacity*
- *Meets EPA Emission Standards*

TABLE OF CONTENTS

GENERAL SAFETY PROCEDURES.....	4
PACKAGE CONTENTS.....	8
GENERATOR COMPONENTS.....	9
PREPARING THE GENERATOR FOR USE.....	10
Using the Generator for the First Time.....	10
Step 1- Add Oil.....	10
Step 2- Add Gasoline.....	11
Step 3- Ground the Generator.....	11
Subsequent Use of the Generator.....	12
Step 1- Check the Oil.....	12
Step 2- Check the Gas Level.....	12
Step 3- Ground the Generator.....	13
STARTING THE GENERATOR.....	13
USING THE GENERATOR.....	14
AC Usage.....	14
DC Usage.....	17
STOPPING THE GENERATOR.....	18
MAINTENANCE / CARE.....	19
Cleaning the Generator.....	19
Checking the Oil.....	19
Changing/ Adding Oil.....	20
Air Cleaner Maintenance.....	21
Fuel Filter Cup Cleaning.....	22
Spark Plug Maintenance.....	22
Emptying the Gas Tank.....	23
STORAGE / TRANSPORT PROCEDURES.....	23
SPECIFICATIONS.....	24
TROUBLESHOOTING.....	25
EXPLODED VIEW AND PARTS LIST.....	26
WIRING DIAGRAM.....	28
WARRANTY.....	30

Notice Regarding Emissions

Engines that are certified to comply with U.S. EPA emission regulations for SORE (Small Off Road Equipment), are certified to operate on regular unleaded gasoline, and may include the following emission control systems: (EM) Engine Modifications and (TWC) Three-Way Catalyst (if so equipped).

GENERAL SAFETY PROCEDURES

Please familiarize yourself with the following safety symbols and words:

The safety alert symbol  is used with one of the safety words (**DANGER**, **CAUTION**, or **WARNING**) to alert you to hazards. Please pay attention to these hazard notices both in this manual and on the generator.

DANGER: Indicates a hazard that will result in serious injury or death if instructions are not followed.

WARNING: Indicates a strong possibility of causing serious injury or death if instructions are not followed.

CAUTION: Indicates a possibility of personal injury or equipment damage if instructions are not followed.



If you have any questions regarding the hazard and safety notices listed in this manual or on the product, please call (888) 315-3080 M-F 8-5CT before using the generator.

 DANGER: This generator produces poisonous carbon monoxide gas when running. This gas is both odorless and colorless. Even if you do not see or smell gas, carbon monoxide may still be present. Breathing this poison can lead to headaches, dizziness, drowsiness, and eventually death.

- Use outdoors ONLY in non-confined areas.
- Keep several feet of clearance on all sides to allow proper ventilation of the generator.

 WARNING: The exhaust from this product contains chemicals known to the State of California to cause cancer, birth defects, or other reproductive harm.

 WARNING: This generator may emit highly flammable and explosive gasoline vapors, which can cause severe burns or even death. A nearby open flame can lead to explosion even if not directly in contact with gas.

- Do not operate near open flame.
- Do not smoke near generator.
- Always operate on a firm, level surface.
- Always turn generator off before refueling. Allow generator to cool for at least 2 minutes before removing fuel cap. Loosen cap slowly to relieve pressure in tank.
- Do not overfill gas tank. Gas may expand during operation. Do not fill to the top of the tank.
- Always check for spilled gas before operating.
- Empty gasoline tank before storing or transporting the generator..
- Before transporting, turn fuel valve to off and disconnect spark plug.

⚠ WARNING: This generator produces powerful voltage, which can result in electrocution.

- ALWAYS ground the generator before using it (see the “Grounding the Generator” portion of the “PREPARING THE GENERATOR FOR USE” section).
- Generator should only be plugged into electrical devices, either directly or with an extension cord. NEVER connect to a building electrical system without a qualified electrician. Such connections must comply with local electrical laws and codes. Failure to comply can create a backfeed, which may result in serious injury or death to utility workers.
- Use a ground fault circuit interrupter (GFCI) in highly conductive areas such as metal decking or steel work. GFCIs are available in-line with some extension cords.
- Do not use in rainy or wet conditions.
- Do not touch bare wires or receptacles (outlets).
- Do not allow children or non-qualified persons to operate.

⚠ WARNING: This generator produces heat when running. Temperatures near exhaust can exceed 150° F (65° C).

- Do not touch hot surfaces. Pay attention to warning labels on the generator denoting hot parts of the machine.
- Allow generator to cool several minutes after use before touching engine or areas which heat during use.

CAUTION: Misuse of this generator can damage it or shorten its life.

- Use generator only for its intended purposes.
- Operate only on dry, level surfaces.
- Allow generator to run for several minutes before connecting electrical devices.
- Shut off and disconnect any malfunctioning devices from generator.
- Do not exceed the Wattage capacity of the generator by plugging in more electrical devices than the unit can handle (see “PRECAUTIONS-OVERLOADING THE GENERATOR”).
- Do not turn on electrical devices until *after* they are connected to the generator.
- Turn off all connected electrical devices before stopping the generator.

In addition to the above safety notices, please familiarize yourself with the safety and hazard markings on the generator.

WARNING! RISK OF EXPLOSION

- Stop generator before refueling.
- Check for spilled fuel.
- Do not operate near open flame.

WARNING! RISK OF ELECTRIC SHOCK

This generator produces high voltage

- Always ground properly before use.
- Do not connect to any building electrical system.
- Never use in rainy or wet conditions.
- Never touch bare wires or receptacles.
- Never allow children or non-qualified persons to operate.

DO NOT RETURN TO STORE

IF YOU ARE HAVING PROBLEMS WITH THIS GENERATOR, CALL OUR CUSTOMER HELP LINE.
(888) 315-3080
 M-F 8-5 CT

STOP

CAUTION! POISONOUS GAS

Generator exhaust contains toxic carbon monoxide gas. **NEVER** operate indoors or in poorly ventilated areas.

CAUTION!

DO NOT OVERLOAD GENERATOR (SEE MANUAL).
 DO NOT CONNECT TO ANY BUILDING ELECTRICAL SYSTEM.

IMPORTANT!

CONNECT GROUND TO EARTH BEFORE OPERATING. ↑

IMPORTANT! BEFORE STARTING:

1. Make sure unit is properly grounded.
2. Check that crankcase is sufficiently filled with oil.
3. Turn off or unplug all devices connected to generator.

OPERATION SUMMARY

1. Place engine switch into "on" position.
2. Turn fuel valve to "on" position.
3. Pull starting cord.
4. If engine fails to start, adjust choke and pull cord again.
5. Allow generator to run for several minutes before connecting devices.

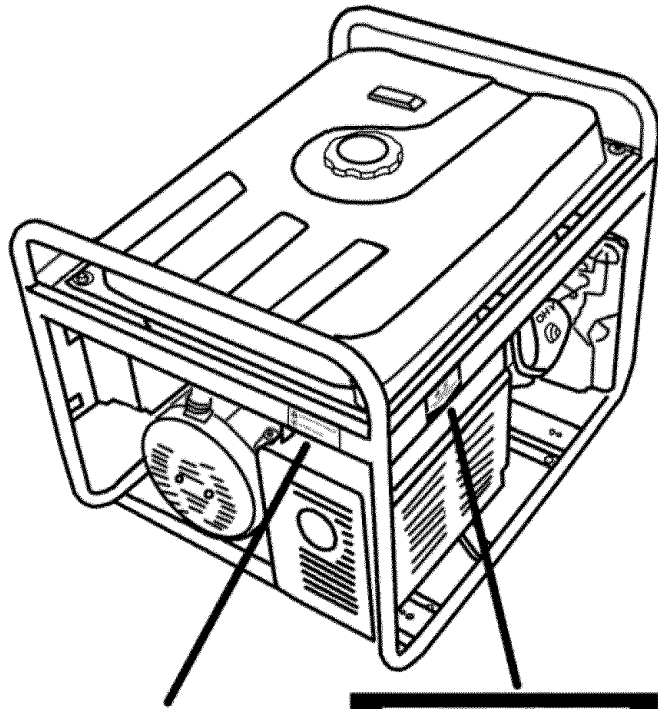

 CAUTION! HOT EXHAUST
 DO NOT TOUCH





  CAUTION!
HIGH TEMPERATURE
DO NOT TOUCH

PACKAGE CONTENTS

Your generator comes with the items listed below. Please check to see that all of the following items are included with your generator.

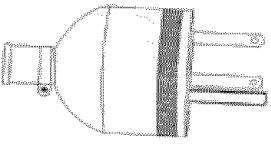
 **If you are missing components DO NOT RETURN TO STORE, please call (888) 315-3080 M-F 8-5 CT for customer service.**

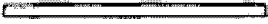
ITEM LIST

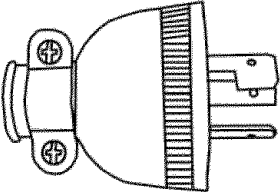
	<p>AC plug for connecting 240 Volt electrical devices</p>
 <p>PLUG WRENCH</p>  <p>HANDLE BAR</p>	<p>Spark plug wrench</p>
	<p>Flat Head Screwdriver</p>
	<p>Set of 2 DC connector wires for connecting 12 Volt automotive-type batteries.</p>
	<p>Plug for connecting 240Volt electrical devices</p>

GENERATOR COMPONENTS

Please familiarize yourself with the locations and functions of the various components and controls of your generator.

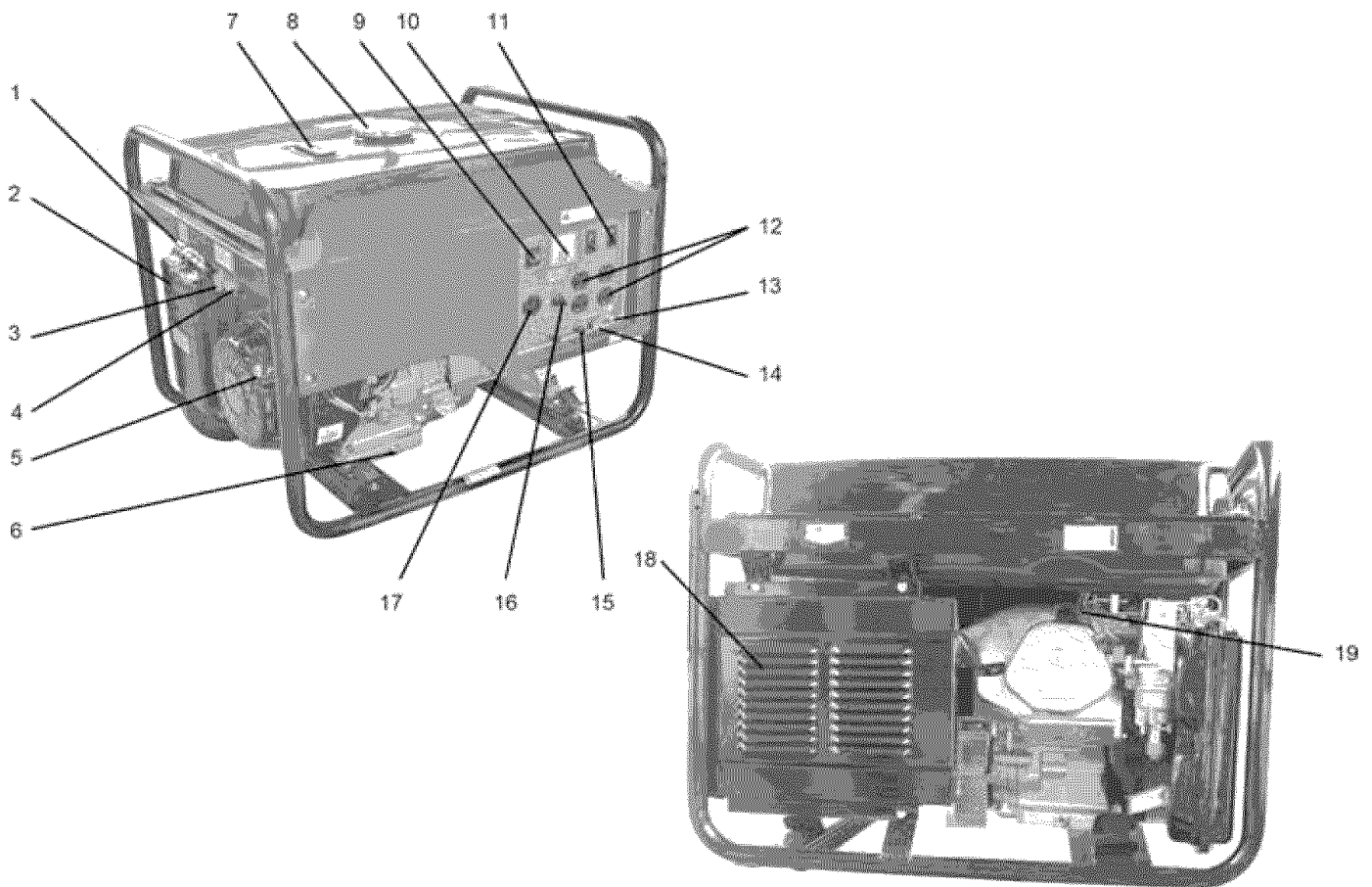

- (1) Choke Rod-** Adjusts the amount of air let into the engine.
- (2) Air cleaner-** a removable, cleanable, sponge-like element that limits the amount of dirt pulled into the engine.
- (3) Fuel valve-** Allows fuel to enter engine.
- (4) Fuel Filter Cup-** Traps dirt and water from fuel before it enters the engine.
- (5) Recoil Starter-** Pull-cord for starting engine.
- (6) Oil Fill and Dipstick-** Location for checking and filling engine oil.
- (7) Fuel Gauge-** Indicates the amount of fuel in the tank.
- (8) Fuel Cap-** Access to the fuel tank for adding fuel.
- (9) Engine Switch-** Used to start/stop engine.

- (10) Volt Meter-** Provides reading of voltage output.
- (11) Circuit Breakers-** Reset switches that protects the generator from electrical overload.
- (12) 120 Volt AC Receptacles-** Use to connect electrical devices that run 120 Volt, 60 Hz, single phase, AC current.
- (13) Ground Terminal-** Connect grounding wires here to properly ground unit.
- (14) Protector-** AC output protection when over current.
- (15) 12 Volt DC Terminal-** Use for charging 12 Volt automotive-type batteries only.
- (16) Voltage switch-** Use to switch between 120 and 240 voltage.
- (17) 240 Volt AC Receptacle-** Use to connect electrical devices that run 240 Volt, 60 Hz, single phase, AC current.
- (18) Muffler-** Reduces engine noise.
- (19) Spark plug-** Provides proper engine ignition.

PREPARING THE GENERATOR FOR USE

Using the Generator for the First Time

 *The following section describes steps you must follow to prepare your generator for first-time use. If after reading this section, you are unsure about how to perform any of the steps please call (888) 315-3080 M-F 8-5 CT for customer service. Failure to perform these steps properly can damage your generator or shorten its life.*

If you are using the generator for the first time, there are a few steps you must take to prepare it for operation:

Step 1- Add oil

The generator requires engine oil to operate properly. The generator, when new from the package, contains *no* oil in the crankcase. You must add the proper amount of oil before operating the generator for the first time. This amount, which is equal to the oil capacity of the engine crankcase, is 37 fluid oz.

For general use, we recommend SAE 10W/30 oil to fill the engine crankcase.

To add oil, follow these steps:

1. Make sure the generator is on a level surface.
2. Unscrew the oil filler/dipstick cap from the engine as shown in figure 1.
3. Using a funnel, add 37 fluid ounces of oil into the crankcase. You will know the crankcase is full when the oil level has reached the lower lip of the opening you have just poured the oil into (see figure 2).
4. Replace oil filler cap.

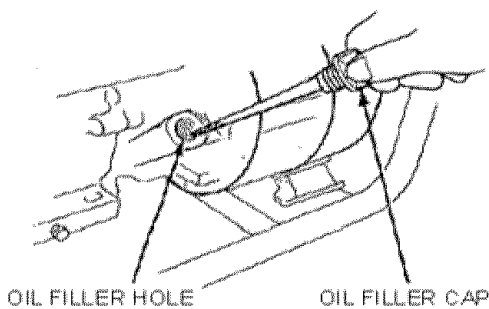

Figure 1- Unscrewing the oil cap

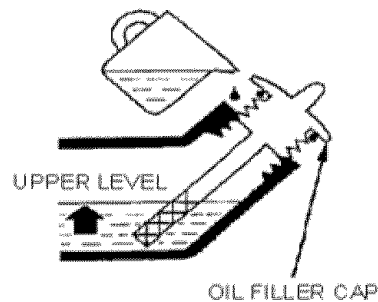

Figure 2- Adding oil

Step 2- Add Gasoline

▲ WARNING: Gasoline and gas fumes are highly flammable.

- **Do not fill tank near an open flame.**
- **Do not overfill. Always check for fuel spills.**

To ensure that the generator runs smoothly use only FRESH, UNLEADED GAS WITH AN OCTANE RATING OF 87 OR HIGHER. To add gasoline:

1. Make sure the generator is on a level surface.
2. Unscrew gas cap and set aside (NOTE: the gas cap may be tight and hard to unscrew).
3. Slowly add unleaded gasoline to the fuel tank. The capacity of the gas tank is 6.5 gallons. Be careful not to overfill. The fuel gauge on the top of the generator indicates how much gasoline is in the generator gas tank. NOTE: Gas can expand. Do not fill the gas tank to the very top.
4. Replace fuel cap and wipe up any spilled gasoline with a dry cloth.

IMPORTANT:

- Never use an oil/gasoline mixture.
- Never use old gas.
- Avoid getting dirt or water in the fuel tank.
- Gas can age in the tank and make it hard to start up the generator in the future. Never store generator for extended periods of time with fuel in the tank.

Step 3- Ground the Generator

▲ WARNING: Failure to properly ground the generator can result in electrocution.

Ground the generator by tightening the grounding nut against a grounding wire (see figure 3). A generally acceptable grounding wire is a No. 12 AWG (American Wire Gauge) stranded copper wire. This grounding wire should be connected at the other end to a copper or brass grounding rod that is driven into the earth.

Grounding codes can vary by location. Please contact a local electrician to check the grounding regulations for your area.

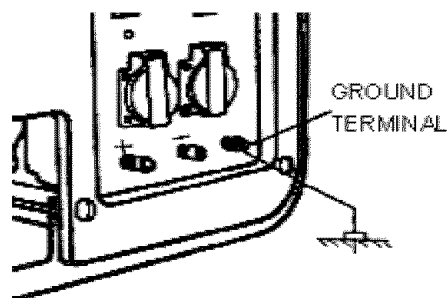

Figure 3- Attaching the Grounding Wire to the Generator

Subsequent Use of the Generator

If this is not your first time using the generator there are still steps you should take to prepare it for operation.

IMPORTANT: At this point you should be familiar with the procedures described in the first portion of this section entitled “Using the Generator for the First Time.” If you have not yet read this section, go back and read it now.

Step 1- Check the Oil

The generator is equipped with an automatic shutoff to protect it from damage due to low oil. Nonetheless, you should check the oil level of the engine before each use to ensure that the engine crankcase has a sufficient amount. To check the oil level:

1. Make sure the generator is on a level surface.
2. Unscrew the oil filler/dipstick cap.
3. With a dry cloth, wipe the oil off of the stick on the inside of the cap.
4. Insert the dipstick as if you were replacing the cap and then remove again. There should now be oil on the stick. If there is no oil on the stick, or oil only at the very end of the stick, you should add oil until the engine crankcase is filled (see “Adding Oil” portion of the “Maintenance” section).
5. Be sure to replace cap when finished checking oil.

NOTE: The oil capacity for your generator can be found in the “Specifications” section of this manual

Step 2 – Check the Gas Level

Before starting the generator, check to see that there is sufficient gasoline in the gas tank. The fuel gauge on top of the generator will indicate the gas level in the tank. Add gas if necessary according to the steps in the “Adding Gasoline” portion of the “Maintenance” section.

▲ WARNING: Gasoline and gasoline fumes are highly flammable.

- **Do not fill tank near an open flame.**
- **Always allow engine to cool for several minutes before refueling.**
- **Do not overfill (check the “Specifications” section for the tank capacity of your generator). Always check for fuel spills.**

IMPORTANT:

- Use only UNLEADED gasoline with an octane rating of 87 or higher.
- Do not use old gas.
- Never use an oil/gasoline mixture.
- Avoid getting dirt or water in the fuel tank.
- Never store generator for extended periods of time with fuel in the tank.

Step 3- Ground the Generator

▲ WARNING: Failure to properly ground the generator can result in electrocution.

Ground the generator by tightening the grounding nut against a grounding wire (see figure 3). A generally acceptable grounding wire is a No. 12 AWG (American Wire Gauge) stranded copper wire. This grounding wire should be connected at the other end to a copper or brass grounding rod that is driven into the earth.

Grounding codes can vary by location. Please contact a local electrician to check the grounding regulations for your area.

STARTING THE GENERATOR

 ***Before starting the generator, make sure you have read and performed the steps in the “Preparing the Generator for Use” section of this manual. If you are unsure about how to perform any of the steps in this manual please call (888) 315-3080 M-F 8-5 CT for customer service.***

▲ CAUTION: Disconnect all electrical loads from the generator before attempting to start.

To start your generator, perform the following steps:

1. Make sure no electrical devices are connected to the generator. Such devices can make it difficult for the engine to start.
2. Check that the generator is properly grounded (see “Ground the Generator” above).
3. Turn the fuel valve to the “on” position (see figure 4).
4. Pull the choke rod to the “closed” position (see figure 5).
5. Set the engine switch to the “on” position.
6. Pull on the recoil starter handle slowly until a slight resistance is felt (see figure 6). Then pull quickly to start the engine. Return cord gently into the machine. Never allow the cord to snap back.
7. If engine fails to start, repeat step 4. **NOTE:** After repeated attempts to start the engine, please consult the troubleshooting guide before attempting again. If problems persist please call **(888) 315-3080 M-F 8-5 CT**.
8. Once the engine has started and run for about a minute, move the choke rod about half way towards the “open” position. Wait another 30 seconds and then move the choke rod all the way to the “open” position.
9. Allow the generator to run for several minutes before attempting to connect any electrical devices.

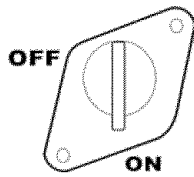

Figure 4- Fuel Valve in the “on” position

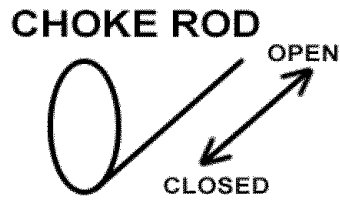

Figure 5- Choke rod positions

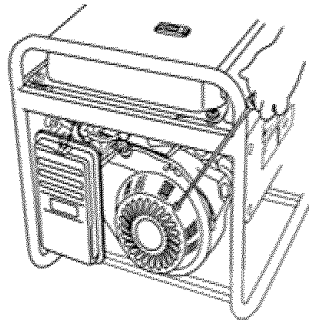

Figure 6- Pulling the start cord

USING THE GENERATOR

Once you have allowed the engine to run for several minutes, you may connect electrical devices to the generator.

AC Usage

You may connect electrical devices running on AC current according to their wattage requirements. The chart in figure 9 shows the rated and surge wattage of your generator.

The *rated wattage* corresponds to the maximum wattage the generator can output on a continuous basis.

The *surge wattage* corresponds to the maximum amount of power the generator can output for a short period of time. Many electrical devices such as refrigerators require short bursts of extra power, in addition the rated wattage listed by the device, to stop and start their motors. The surge wattage ability of the generator covers this extra power requirement.

Model Number	Rated(Running) Wattage	Surge Wattage
5500	5000	5500

Figure 7- generator wattage by model number.

The total running wattage requirement of the electrical devices connected to the generator should not exceed the rated wattage of the generator itself. To calculate the total wattage requirement of the electrical devices you wish to connect, find the rated (or running)

wattage of each device. This number should be listed somewhere on the device or in its instruction manual. If you cannot find this wattage, you may calculate it by multiplying the Voltage requirement by the Amperage drawn:

$$\text{Watts} = \text{Volts} \times \text{Amperes}$$

If these specifications are not available you may estimate the Watts required by your device by using the chart in figure 8.

Once you have found the rated wattage requirement of each electrical device, add these numbers to find the total rated wattage you wish to draw from the generator. If this number exceeds the rated wattage of the generator, DO NOT connect all these devices. Select a combination of electrical devices, which has a total rated wattage lower than or equal to the rated wattage of the generator.

CAUTION- The generator can run at its surge wattage capacity for only a short time. Connect electrical devices requiring a rated (running) wattage equal to or less than the rated wattage of the generator. Never connect devices requiring a rated wattage equal to the surge wattage of the generator.

tool or appliance	rated (running) Watts	additional surge Watts
electric water heater (40 gal)	4000	0
hot plate	2500	0
saw- radial arm	2000	2000
electric stove	1500	0
saw- circular	1500	1500
air compressor (1 HP)	1500	3000
window air conditioner	1200	1800
saw- miter	1200	1200
microwave	1000	0
well water pump	1000	1000
reciprocating saw	960	1040
sump pump	800	1200
refrigerator freezer	800	1200
furnace blower	800	1300
computer	800	0
electric drill	600	900
television	500	0
deep freezer	500	500
garage door opener	480	0
stereo	400	0
box fan	300	600
clock radio	300	0
security system	180	0
dvd player/ vcr	100	0
common light bulb	75	0

.Figure 8- Estimated wattage requirements of common electrical devices.

NOTE: The above wattage figures are estimates. Try to check the wattage listed on your electrical device before consulting this chart

Once you have determined what electrical devices you will be powering with the generator, connect these devices according to the following procedure:

1. Plug in each electrical device with the device turned off.
NOTE: Be sure to attach appliances to the correct receptacle (outlet). Connect standard 120 Volt, single phase, 60 Hz loads **only** to the 120 Volt receptacles. Connect 240 Volt, single phase, 60Hz loads with a 240 V plug **only** to the 240 Volt receptacle See Figure 11 for a depiction of each of these receptacles.
2. Move the voltage select switch to the 120 V position if you are connecting 120 Volt loads. Move the voltage switch to the 240 V position if you are connecting 240 Volt loads. **NOTE:** The generator cannot run 240 Volt and 120 Volt loads at the same time. You must choose one or the other using the voltage select switch.
3. Switch the appropriate circuit breaker to the “on” position. For 240 Volt loads, switch on the circuit breaker marked 23 A. For 120 Volt loads, switch on the circuit breaker marked 46 A.
4. Turn on the connected electrical devices in the order of the amount of power they require beginning with the device with the highest rated wattage requirement.

IMPORTANT: The four 120 Volt receptacles have a total capacity of 46 Amps. However, the capacity of each duplex plug, A and B (see figure 9) is only 23 A. You will not be able to draw more than 23 Amps out of one duplex plug.

CAUTION: Do not connect 50Hz or 3-phase loads to the generator.

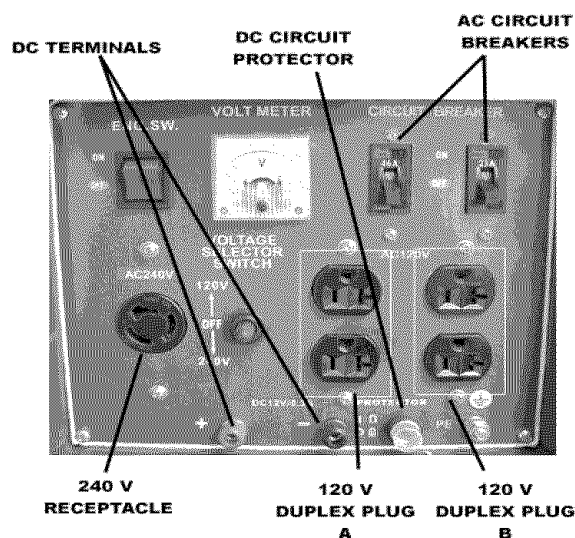

Figure 9- Receptacles available on the generator

SOME NOTES ABOUT POWER CORDS

Long or thin cords can drain the power provided to an electrical device by the generator. When using such cords, allow for a slightly higher rated wattage requirement by the electrical device. See Figure 12 for recommended cords based on the power requirement of the electrical device.

Device Requirements			Max. Cord Length (ft) by Wire Gauge				
Amps	Watts (120V)	Watts (240 V)	#8 wire	#10 wire	#12 wire	#14 wire	#16 wire
2.5	300	600	NR	1000	600	375	250
5	600	1200	NR	500	300	200	125
7.5	900	1800	NR	350	200	125	100
10	1200	2400	NR	250	150	100	50
15	1800	3600	NR	150	100	65	NR
20	2400	4800	175	125	75	50	NR
25	3000	6000	150	100	60	NR	NR
30	3600	7200	125	65	NR	NR	NR
40	4800	9600	90	NR	NR	NR	NR

*NR= not recommended

Figure 10- Maximum Extension Cord Lengths by Power Requirement

DC Usage

CAUTION: The DC receptacle is for recharging 12 Volt automotive-type batteries only. Do not connect any other device to this receptacle.

CAUTION: Use the generator only to *recharge* 12 Volt batteries. Never try to jumpstart a car with your generator.

To connect 12 Volt batteries to the DC receptacle:

1. Connect the positive (+) battery cable to the positive (+) terminal.
2. Connect the other end of the positive (+) battery cable to the generator.
3. Connect the negative (-) battery cable to the battery negative (-) terminal.
4. Connect the other end of the negative (-) battery cable to the generator's negative (-) terminal.
5. Start the generator.
6. When disconnecting, always disconnect the wires from the generator first to avoid a spark.

NOTE: If the DC terminal becomes overloaded, the DC circuit protector will switch off and the power to this terminal will be cut. If this happens, check the Amperage of the load you are connecting. Press the DC circuit protector button to restart the power to this terminal.

▲ DANGER: Storage batteries emit highly explosive hydrogen gas when charged. Batteries also contain acid, which can cause severe chemical burns.

- Do not allow open flames or cigarettes nearby for several minutes after charging a battery.
- Always wear protective goggles and rubber gloves when charging a battery.
 - If battery acid gets on your skin, flush with water.
 - If battery acid gets in your eyes, flush with water and call a physician immediately.
 - If battery acid is swallowed, drink large quantities of milk and call a physician immediately.

STOPPING THE GENERATOR

To stop the generator:

1. Turn off, then unplug all connected electrical devices.
2. Switch the circuit breaker to the “off” position.
3. Allow the generator to run for several more minutes with no electrical devices connected. This helps stabilize the temperature of the generator.
4. Set the engine switch to the “off” position.
5. Turn the fuel valve to the “off” position.

▲ WARNING: Allow the generator to cool for several minutes before touching areas that become hot during use.

CAUTION: Allowing gas to sit in the generator tank for long periods of time without use can make it difficult to start the generator in the future. Never store generator for extended periods of time with fuel in the tank.

MAINTENANCE / CARE

Proper routine maintenance of your generator will help prolong the life of your machine. Please perform maintenance checks and operations according the schedule in figure 13.



If you have questions about any of the maintenance procedures listed in this manual, please call **(888) 315-3080** M-F 8-5CT.

CAUTION: Never perform maintenance operations while the generator is running.

Recommended Maintenance Schedule

		each use	every month or 20 hrs	every 3 months or 50 hrs	every 6 months or 100 hrs	every year or 300 hrs
Engine oil	check level	x				
	replace		x			
Air cleaner	check	x				
	clean			x		
fuel filter cup	clean				x	
spark plug	check/ clean				x	
gas tank	check gas level	x				
	clean					x

Figure 11- Recommended maintenance schedule

Cleaning the Generator

Always try to use your generator in a cool dry place. However, in the event your generator becomes dirty you may clean the exterior with one or more of the following:

- a damp cloth
- a soft brush
- a vacuum
- pressurized air

Never clean your generator with a bucket of water or a hose. Water can get inside the working parts of the generator and cause a short circuit or corrosion.

Checking the Oil

The generator is equipped with an automatic shutoff to protect it from running on low oil. Nonetheless, you should check the oil level of the generator before each use to ensure that the generator crankcase has a sufficient amount. To check the oil level:

1. Make sure the generator is on a level surface.
2. Unscrew the oil filler/dipstick cap (see figure 12).
3. With a dry cloth, wipe the oil off of the stick on the inside of the cap.
4. Insert the dipstick as if you were replacing the cap and then remove again. There should now be oil on the stick. If there is no oil on the stick, or oil only at the

very end of the stick, you should add oil until the engine crankcase is filled. See “Changing/ Adding Oil” in this section.

5. Be sure to replace cap when finished checking oil.

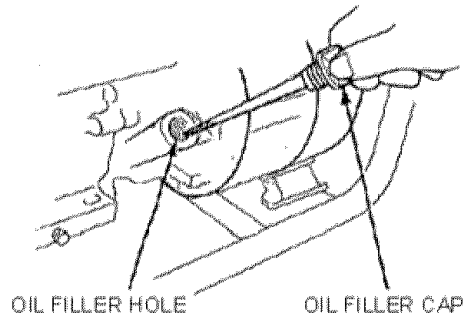

Figure 12- Checking the oil

Changing/ Adding Oil

You should check the oil level of your generator according to the maintenance schedule in figure 11. When the oil level is low you will need to add oil until the level is sufficient to run the generator.

The oil capacity of your generator engine is 37 fluid ounces.

It is only necessary to drain the oil from the crankcase if it has become contaminated with water or dirt. In this case, you can drain the oil from the generator according to the following steps:

1. Place a bucket underneath the generator to catch oil as it drains.
2. Using a hex wrench, unscrew the oil drain plug, which is located on the crankcase underneath the oil filler/dipstick cap (see figure 13). Allow all the oil to drain from the generator.
3. Replace the oil drain plug and tighten with a hex wrench.

To add oil to the crankcase, follow these steps:

1. Make sure the generator is on a level surface.
2. Unscrew the oil filler/dipstick cap from the engine.
3. Using a funnel, add high detergent motor oil to the crankcase. We recommend SAE 10W/30 motor oil for general use. When full, the oil level should come close to the top of the oil fill opening (see figure 14).

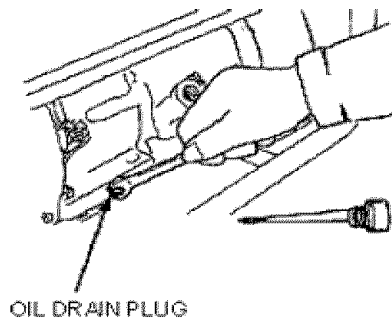

OIL DRAIN PLUG

Figure 13- Draining oil

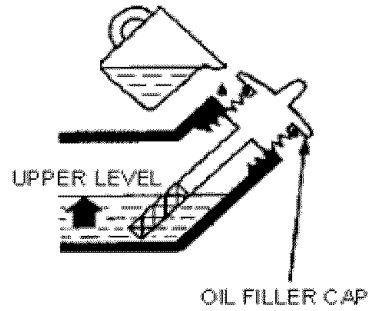

OIL FILLER CAP

Figure 14- Adding oil

NOTE: Never dispose of used motor oil in the trash or down a drain. Please call your local recycling center or auto garage to arrange oil disposal.

Air Cleaner Maintenance

Routine maintenance of the air cleaner helps maintain proper air flow to the carburetor. Occasionally check that the air cleaner is free of excessive dirt.

1. Unhinge the clasps at the top and bottom of the air cleaner cover (see figure 15).
2. Remove the sponge-like elements from the casing.
3. Wipe the dirt from inside the empty air cleaner casing
4. Wash the sponge-like elements in household detergent and warm water. Allow to dry.
5. Soak the dry elements in engine oil. Squeeze out any excess oil.
6. Replace the sponge-like elements in the air cleaner casing and replace the cover.

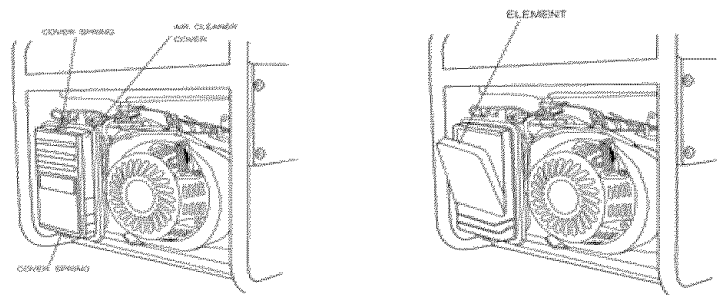

Figure 15- Removing the air cleaner casing.

Fuel Filter Cup Cleaning

The fuel filter cup is a small well underneath the fuel valve. It helps to trap dirt and water that may be in your fuel tank before it can enter the engine. To clean the fuel filter cup:

1. Turn the fuel valve to the “off” position.
2. Unscrew the fuel filter cup from the fuel valve using a wrench. Turn the valve toward you to unscrew (see figure 16).
3. Clean the cup of all sediment. Using a rag or brush.
4. Reinstall the fuel filter cup.

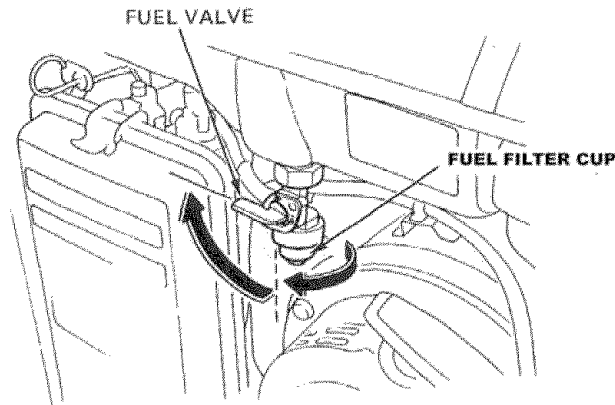

Figure 16- Removing the Fuel Filter Cup

Spark Plug Maintenance

The spark plug is important for proper engine operation. A good spark plug should be intact, free of deposits, and properly gapped. To inspect you spark plug:

1. Pull on the spark plug cap to remove it.
2. Unscrew the spark plug from the generator using the spark plug wrench included with this product (see figure 17).
3. Visually inspect the spark plug. If it is cracked or chipped, discard and replace with a new spark plug. We recommend using a F6RTC spark plug such as NGK BPR5ES.
4. Measure the plug gap with a gauge (see figure 18). The gap should be 0.7-0.8mm (0.028-0.031in).
5. If you are re-using the spark plug, use a wire brush to clean any dirt from around the spark plug base and then re-gap the spark plug..
6. Screw the spark plug back into its place on the generator using the spark plug wrench. Replace the spark plug cap.

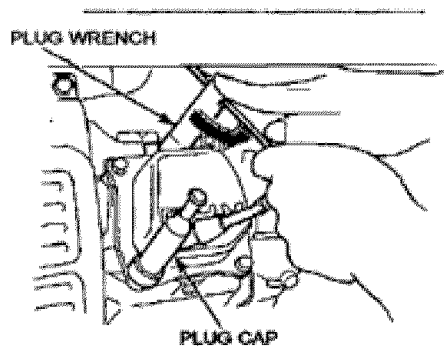

Figure 20- Removing the spark plug

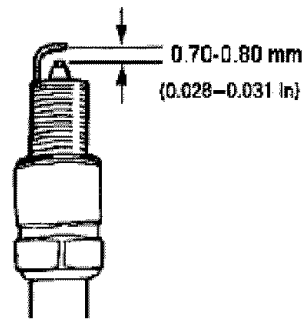

Figure 21- Measuring the spark plug gap

Emptying the Gas Tank

Before storing your generator for extended periods of time, you should drain your generator of gasoline. To drain the generator of gas:

1. Turn the fuel valve to the “off” position.
2. Remove the fuel filter cup (see “Removing the Fuel Filter Cup” earlier in this section.
3. Empty the fuel filter cup of any fuel.
4. With a receptacle underneath the generator to catch the gas, turn the fuel valve to the “on” position. Drain all the gas from the generator.
5. Turn the fuel valve to the “off” position.
6. Replace the fuel filter cup.
7. Store the emptied gasoline in a suitable place.

▲ CAUTION: Do not store fuel from one season to another.

STORAGE / TRANSPORT PROCEDURES

▲ CAUTION: Never place any type of storage cover on the generator while it is still hot.

When transporting or storing your generator for extended periods of time:

- Empty the gas tank (see “Emptying the Gas Tank” in the “Maintenance” section).
- Disconnect the spark plug.
- Do not obstruct any ventilation openings.
- Keep the generator in a cool dry area.

SPECIFICATIONS

Generator

AC Output

Rated Wattage	5000 W
Surge Wattage	5500 W
Rated Voltage	120/240 V
Rated Amperage	46 A
Rated Frequency	60 Hz
Phase	Single

DC Output

Voltage	12 V
Amperage	8.3 A

Dimensions(in):	length= 27 width= 21 height= 21
Dry mass	182 lbs

Engine

Engine type	4-stroke OHV single cylinder with forced air cooling system
Ignition system	non-contact transistor
Displacement	389 cm ³
Fuel tank capacity:	25 L (6.60 US gal.)
Oil capacity	1.1 L (37 fl oz.)
Run time on 50% load	10 hrs

TROUBLESHOOTING

IMPORTANT: If trouble persists please call our customer help line at (888) 315-3080 M-F 8-5.

Problem	Cause	Solution
Engine will not start	Engine switch is set to "off".	Set engine switch to "on".
	Fuel valve is turned to "closed".	Turn fuel valve to "open" position.
	Choke is open.	Close the choke
	Engine is out of gas.	Add gas.
	Engine is filled with contaminated or old gas	Change the gas in the engine.
	Spark plug is dirty.	Clean spark plug.
	Spark plug is broken.	Replace spark plug.
	Generator is not on level surface.	Move generator to a level surface to prevent low oil shutdown from triggering.
	Oil is low	Add or replace oil.
Engine runs but there is no electrical output	Circuit breaker is off.	Set the circuit breaker to the "on" position.
	Bad connecting wires/cables.	If you are using an extension cord, try a different one.
	Bad electrical device connected to generator.	Try connecting a different device.
Generator runs but does not support all electrical devices connected.	Generator is overloaded	Try connecting fewer electrical loads to the generator.
	Short in one of the connected devices.	Try disconnecting any faulty or short-circuited electrical loads.
	Air cleaner is dirty.	Clean or replace air cleaner.

EXPLODED VIEW AND PARTS LIST

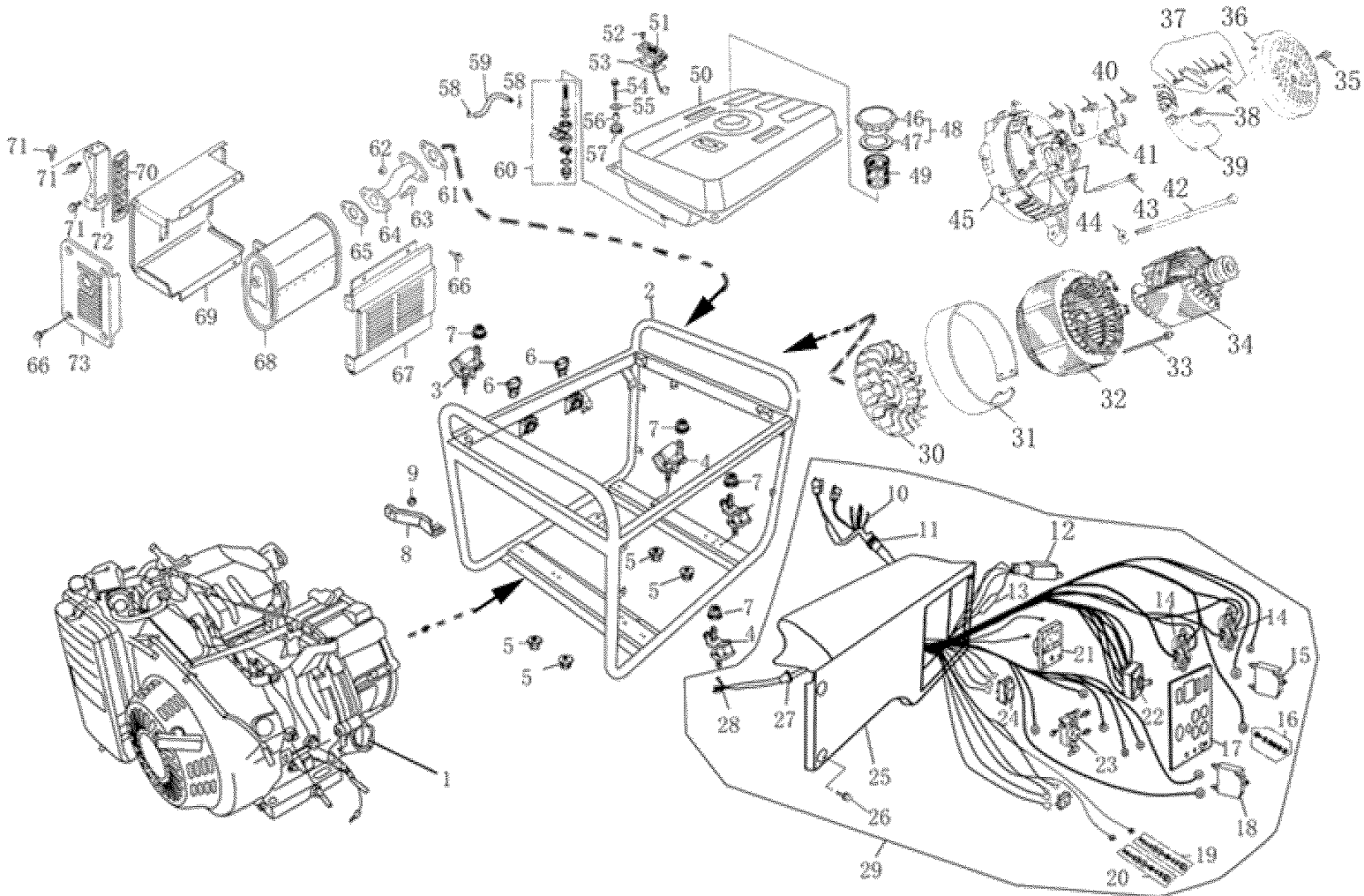

Item	Part	Qty	Description	Item	Part	Qty	Description
1	100000-248	1	GASOLINE ENGINE	38	SB0516	2	SCREW TAPPING M5X16
2	227100-225	1	FRAME COMP	39	228200-248	1	REGULATOR ASSY., AUTOMATIC VOLTAGE
3	227351-248	2	BOTTOM RUBBER LEFT	40	228003-248	1	TIE, CABLE
4	227352-248	2	BOTTOM RUBBER RIGHT	41	228154-248	1	BRUSH ASSY
5	M81000	4	FLANGE NUT M10	42	080207-100	1	BOLT, HEX., 10×210
6	214006-248	2	RUBBER PAD FRAME	43	SB06H9	4	BOLT, FLANGE, 6×179
7	M80800	4	FLANGE NUT M8	44	080712-100	1	WASHER, $\phi 10.2 \times \phi 30 \times 4$
8	227001-248	1	STAY AIR CLEANER	45	228001-248	1	HOUSING, RR
9	SB0614	1	SCREW TAPPING M6X14	46	214252-248	1	CAP COMP., FUEL TANK
10	226350-212	1	WIRE HARNESS ASSY	47	214251-248	1	PACKING, FUEL FILLER CAP
11	226352-231	1	BOTTOM MAIN WIRE HARNESS	48	214200-248	1	CAP COMP., FUEL FILLER
12	226054-248	1	FUSE	49	214001-248	1	FILTER, FUEL TANK
13	226057-248	1	RECTIFIER	50	214100-217	1	TANK COMP., FUEL
14	226051-248 (M)	2	120V RECEPTACLE	51	214500-248	1	METER COMP., FUEL
15	226052-253 (M)	2	CIRCUIT BREAKER	52	D30510	2	SCREW, FLAT, 5×10
16	226250-253	1	TERMINAL SET, EARTH	53	000000-M	1	SEAL GASKET
17	226450-217 (M)	1	CONTROL PANEL	54	SB0625	4	BOLT, FLANGE, 6×25
18	226052-253	1	PROTECTOR, CIRCUIT	55	080703-100	4	ASHER, TANK CUSHION
19	226051-253	1	POST, AIRODE	56	214003-248	4	COLLAR, TANK CUSHION
20	226052-253	1	POST, CATHODE	57	214006-248	4	RUBBER, FUEL CUSHION
21	226053-253	1	VOLTMETER ASSY	58	109004	2	CLIP, TUBE
22	000001-M	1	VOLTAGE SWITCH	59	081502-100	1	TUBE, FUEL
23	226051-248	1	CONSENT	60	214400-248	1	COCK COMP., FUEL
24	226450-233	1	IGNITION SWITCH	61	113003-156	1	GASKET, EX., PIPE
25	226062-217	1	WIRE BOX	62	M10800	2	NUT, HEX., 8MM
26	SB0616	4	SCREW TAPPING M6X16	63	SB0825	2	NUT, HEX., 8MM
27	226353-231	1	BOOT, MAIN WIRE HARNESS	64	213007-248	1	PIPE, COMP., EX.
28	226354-212	1	SWITCH WIRE	65	213007-248	1	PIPE, COMP., EX.
29	226000-212 (M)	1	CONTROL PANEL ASSY	66	SB0610	7	BOLT, FLANGE, 6×10
30	228005-248	1	GENERATOR FAN	67	213004-248	1	PROTECTOR COMP., MUFFLER OUTER
31	228153-248	1	STATOR COVER	68	213100-248	1	MUFFLER COMP.
32	228152-252	1	STATOR ASSY	69	213003-248	1	PROTECTOR COMP., MUFFLER INNER
33	SB05M4	2	BOLT, 5×214	70	213006-248	1	SEAL, PROTECTOR MUFFLER
34	228153-252	1	ROTOR COMP.	71	SB0816	4	SEAL, PROTECTOR MUFFLER
35	SB0512	2	SCREW TAPPING M5X12	72	213200-248	1	STAY COMP., MUFFLER
36	228002-248	1	GENERATOR END COVER	73	213005-248	1	PROTECTOR, MUFFLER SIDE
37	228156-248	1	TERMINAL, VOLT CHANGE				

WIRING DIAGRAM

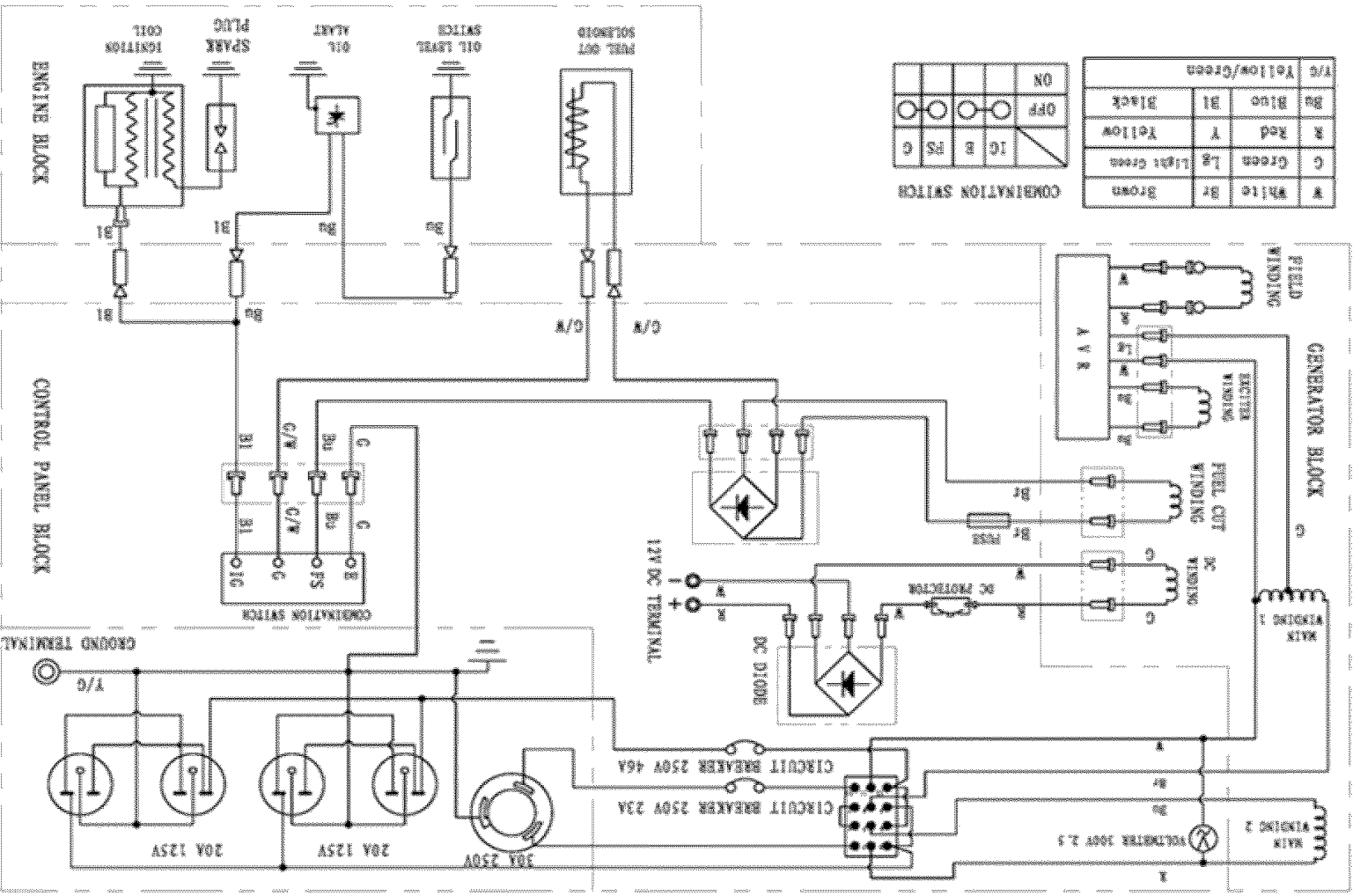

W	White	BY	Brown
C	Green	LG	Light Green
M	Red	Y	Yellow
Bu	Blue	B1	Black
Y/G	Yellow/Green		

ON				
OFF	○	○	○	○
	IC	B	FS	C

LIMITED WARRANTY FOR POWER PRO™ GENERATORS FROM WEN POWER™

Remember to save your receipt and to accurately fill out and mail your product registration card. You must provide proof of purchase for all warranty work.

Power Pro™ generators are warranted to be free from defects in materials and workmanship for a period of one (1) year from date of original purchase. Generators used for Commercial or Rental use have a warranty period of 90 days from date of original purchase. Keep purchase receipt and mail in the product registration card for proof of purchase.

Power Pro™ by WEN Power™ will repair or replace, at its discretion, any part that is proven to be defective in materials or workmanship under normal use during the one (1) year warranty period. Warranty repairs or replacements will be made without charge for parts or labor. Parts replaced during warranty repairs will be considered as part of the original product and will have the same warranty period as the original product.

To exercise the warranty, **DO NOT RETURN TO RETAILER**. Instead, call the toll free Customer Service number: **(888) 315-3080** and you will be instructed on where to take the generator for warranty service. Take the generator and proof of purchase (your receipt) to the repair facility recommended by the Customer Service Representative.

The warranty does not extend to generators damaged or affected by fuel contamination, accidents, neglect, misuse, unauthorized alterations, use in an application for which the product was not designed and any other modifications or abuse.

Power Pro™ by WEN Power™ is not liable for any indirect, incidental or consequential damages from the sale or use of this product. Any implied warranties are limited to one (1) year as stated in this written limited warranty. Some states do not allow the exclusion or limitation of incidental or consequential damages. Some states do not allow limitation on the length of an implied warranty. This warranty gives you specific legal rights, and you may have other rights that vary from state to state.

Power Pro by Wen Power™ . Elgin, IL 60123. www.wenproducts.com.