

WESLO® pursuit 530

Model No. 831.21520.0

Serial No. _____

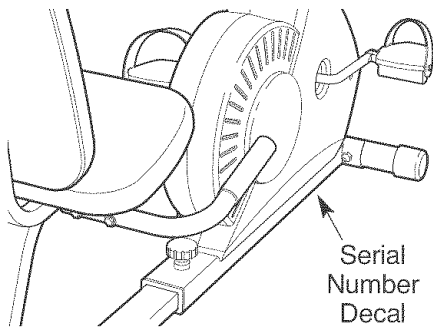

- Assembly
- Operation
- Maintenance
- Part List and Drawing

▲ CAUTION

Read all precautions and instructions in this manual before using this equipment. Keep this manual for future reference.

BIKE EXERCISER User's Manual

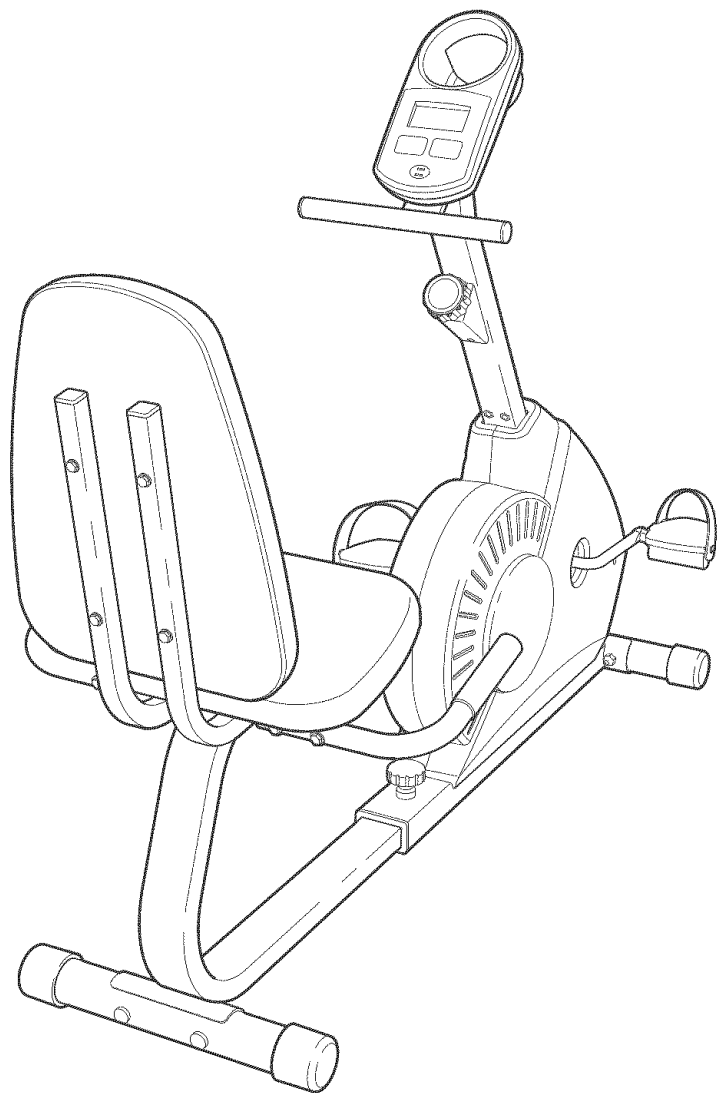

Sears, Roebuck and Co., Hoffman Estates, IL 60179

TABLE OF CONTENTS

IMPORTANT PRECAUTIONS	2
BEFORE YOU BEGIN	3
ASSEMBLY	4
HOW TO OPERATE THE EXERCISE CYCLE	8
MAINTENANCE AND TROUBLESHOOTING	11
CONDITIONING GUIDELINES	12
PART LIST	14
EXPLODED DRAWING	15
ORDERING REPLACEMENT PARTS	Back Cover
FULL 90 DAY WARRANTY	Back Cover

IMPORTANT PRECAUTIONS

⚠ WARNING: To reduce the risk of serious injury, read the following important precautions before using the exercise cycle.

1. Read all instructions in this manual and all warnings on the exercise cycle before using the exercise cycle. Use the exercise cycle only as described in this manual.
2. It is the responsibility of the owner to ensure that all users of the exercise cycle are adequately informed of all precautions.
3. The exercise cycle is intended for home use only. Do not use the exercise cycle in a commercial, rental, or institutional setting.
4. Keep the exercise cycle indoors, away from moisture and dust. Place the exercise cycle on a level surface, with a mat beneath it to protect the floor. Make sure that there is enough clearance around the exercise cycle to mount, dismount, and use the exercise cycle.
5. Inspect and properly tighten all parts regularly. Replace any worn parts immediately.
6. Keep children under the age of 12 and pets away from the exercise cycle at all times.
7. The exercise cycle should not be used by persons weighing more than 250 pounds.
8. Wear appropriate clothes when exercising; do not wear loose clothes that could become caught on the exercise cycle. Always wear athletic shoes for foot protection.
9. The pulse sensor is not a medical device. Various factors, including the user's movement, may affect the accuracy of heart rate readings. The pulse sensor is intended only as an exercise aid in determining heart rate trends in general.
10. Always keep your back straight when using the exercise cycle; do not arch your back.
11. If you feel pain or dizziness while exercising, stop immediately and cool down.
12. The exercise cycle does not have a free-wheel; the pedals will continue to move until the flywheel stops.
13. The decal shown on page 3 has been placed on the exercise cycle in the location shown. If the decal is missing, or if it is not legible, please call toll-free 1-866-699-3756 and order a free replacement decal. Apply the decal in the location shown.

⚠ WARNING: Before beginning this or any exercise program, consult your physician. This is especially important for persons over the age of 35 or persons with pre-existing health problems. Read all instructions before using. Sears assumes no responsibility for personal injury or property damage sustained by or through the use of this product.

BEFORE YOU BEGIN

Congratulations for selecting the new WESLO® PURSUIT 530 exercise cycle. Cycling is one of the most effective exercises for increasing cardiovascular fitness, building endurance, and toning the body. The PURSUIT 530 exercise cycle offers a selection of features designed to let you enjoy this healthful exercise in the convenience and privacy of your home.

after reading this manual, please call 1-800-4-MY-HOME® (1-800-469-4663). To help us assist you, please note the product model number and serial number before calling. The model number is 831.21520.0. The serial number can be found on a decal attached to the exercise cycle (see the front cover of this manual).

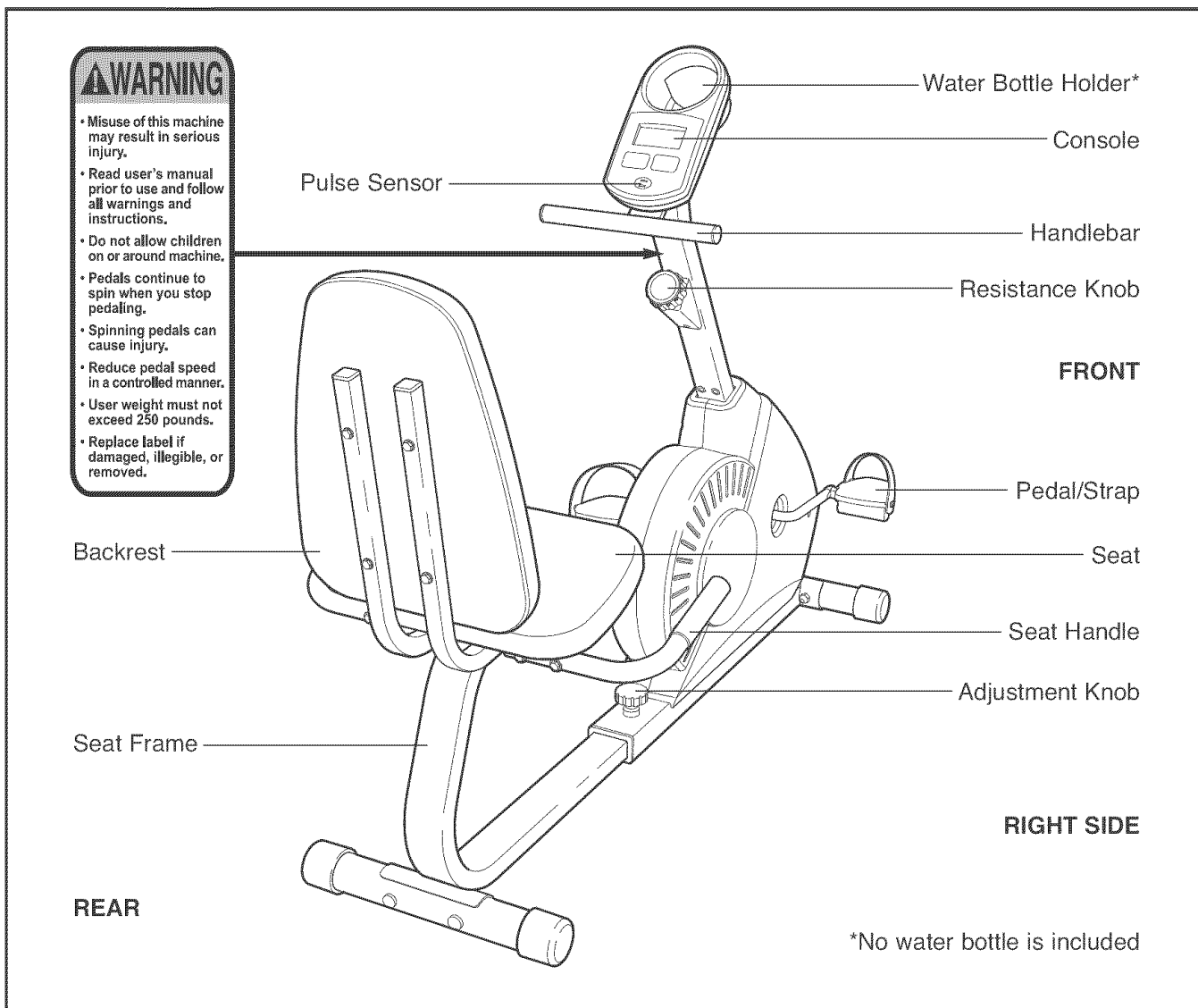

For your benefit, read this manual carefully before you use the exercise cycle. If you have questions

Before reading further, please familiarize yourself with the parts that are labeled in the drawing below.



ASSEMBLY

Assembly requires two persons. Place all parts of the exercise cycle in a cleared area and remove the packing materials. Do not dispose of the packing materials until assembly is completed.

In addition to the included tools, assembly requires a Phillips screwdriver  , two adjustable wrenches  , and pliers  .

Use the drawings below to identify the small parts used for assembly. The number in parentheses below each drawing is the key number of the part, from the PART LIST on page 14. The number following the key number is the quantity needed for assembly. **Note: Some small parts may have been pre-assembled. If a part is not in the parts bag, check to see if it has been pre-assembled. If a part is missing, call toll-free 1-866-699-3756.**

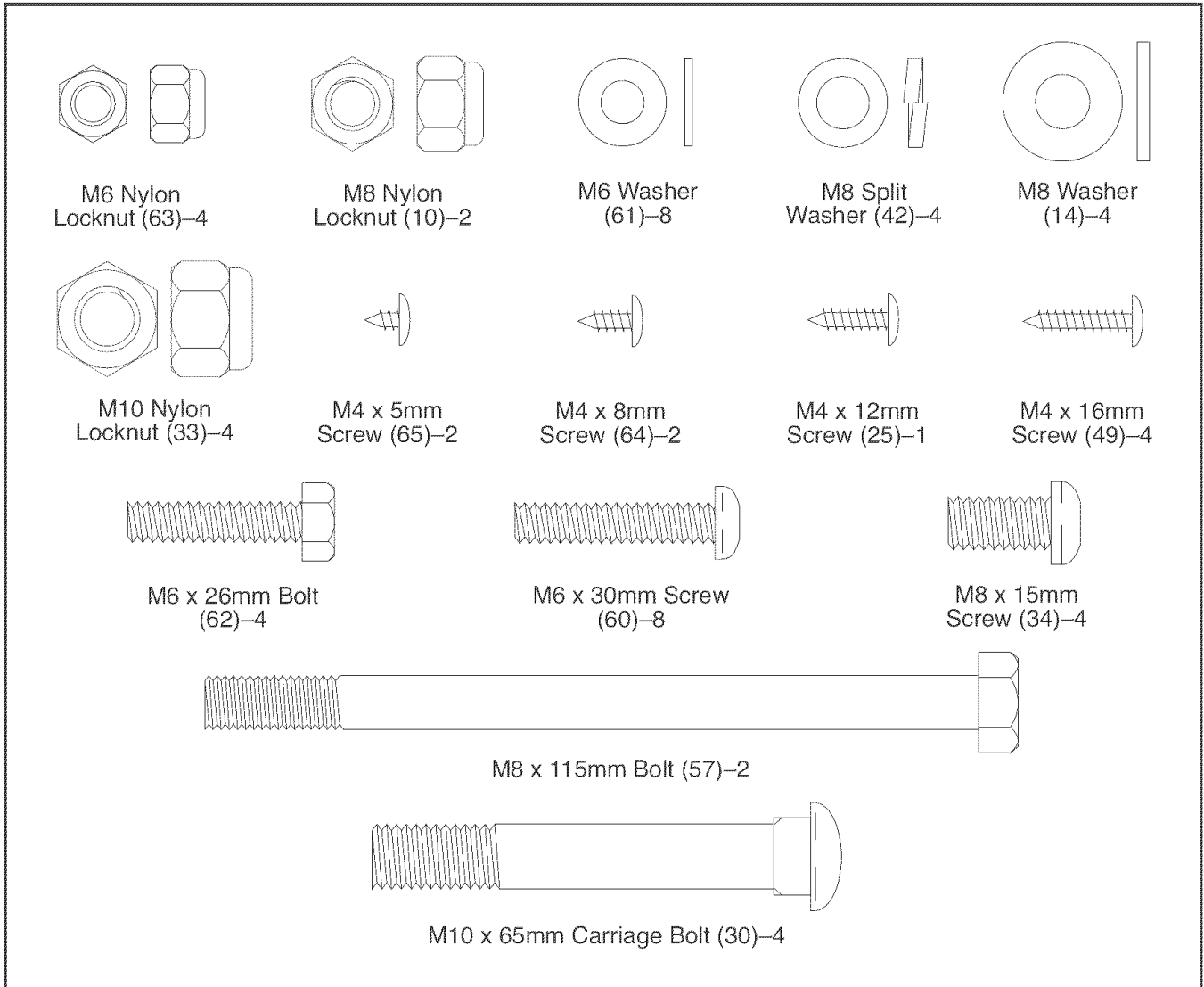

1. While another person lifts the front of the Frame (1) slightly, attach a Stabilizer (2) with two M10 x 65mm Carriage Bolts (30) and two M10 Nylon Locknuts (33).

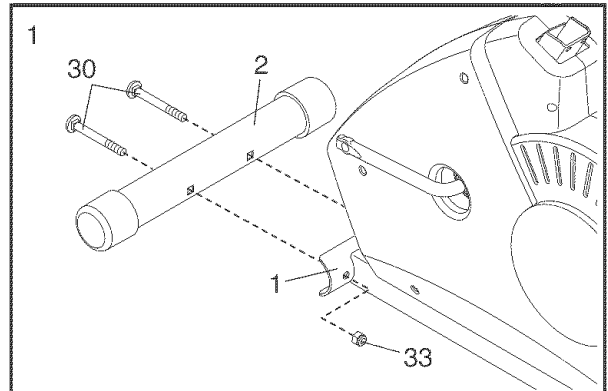

2. Attach the other Stabilizer (2) to the Seat Frame (5) with two M10 x 65mm Carriage Bolts (30) and two M10 Nylon Locknuts (33).

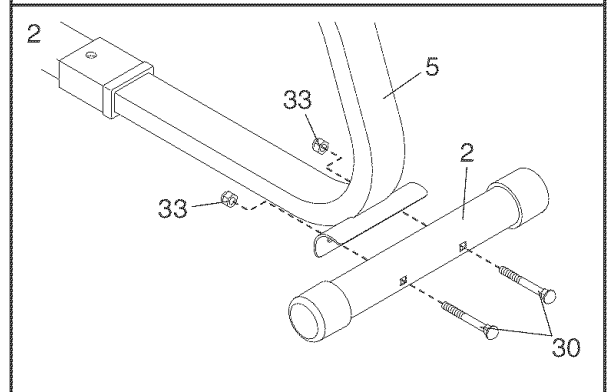

3. Insert the Seat Frame (5) into the Frame (1). Next, firmly press the Seat Frame Bushing (20) into the Frame. Attach the Seat Frame Bushing with two M4 x 5mm Screws (65).

Tighten the Adjustment Knob (9) into the Frame (1).

Carefully tip the exercise cycle onto its side. Attach the two Bumpers (66) to the Frame (1) with two M4 x 8mm Screws (64). Then, tip the exercise cycle back onto the Stabilizers (2).

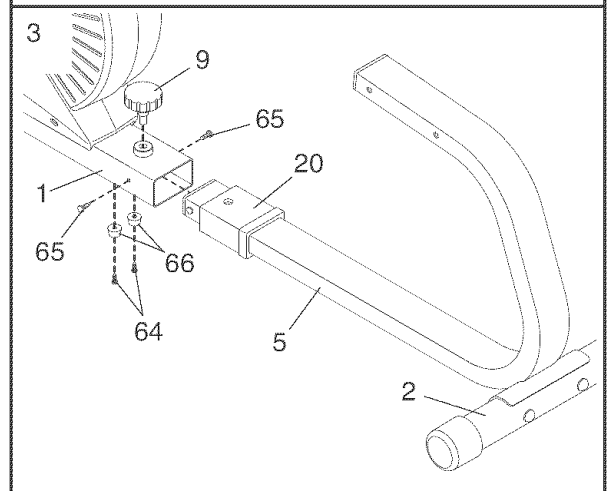

4. Attach the Left and Right Seat Brackets (52, 53) to the Seat Frame (5) with two M8 x 115mm Bolts (57), four M8 Washers (14), and two M8 Nylon Locknuts (10) as shown. **Do not tighten the Nylon Locknuts yet.**

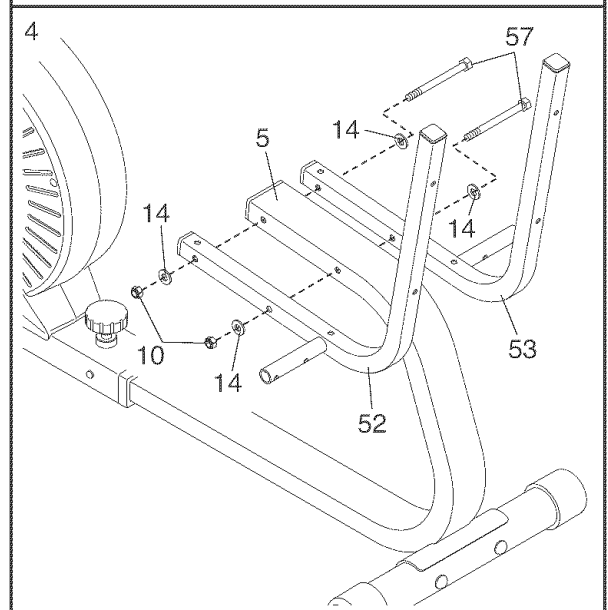

5. Attach a Seat Handle (50) to the round tube on the Left Seat Bracket (52) with two M6 x 26mm Bolts (62) and two M6 Nylon Locknuts (63).

Attach the other Seat Handle (50) to the Right Seat Frame (53) in the same way.

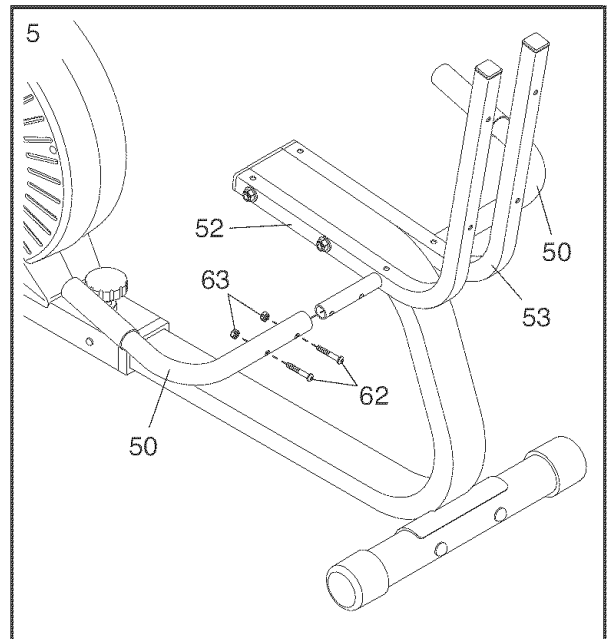

6. Attach the Backrest (54) to the Seat Brackets (52, 53) with four M6 x 30mm Screws (60) and four M6 Washers (61).

See step 4. Tighten the two M8 Nylon Locknuts (10).

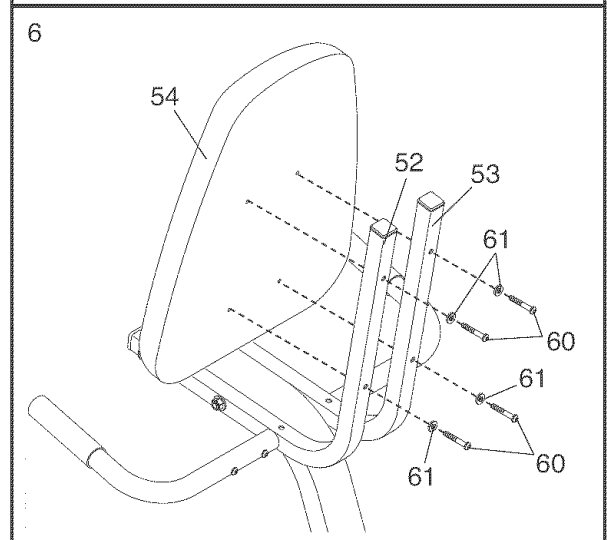

7. Attach the Seat (12) to the Seat Brackets (52, 53) with four M6 x 30mm Screws (60) and four M6 Washers (61).

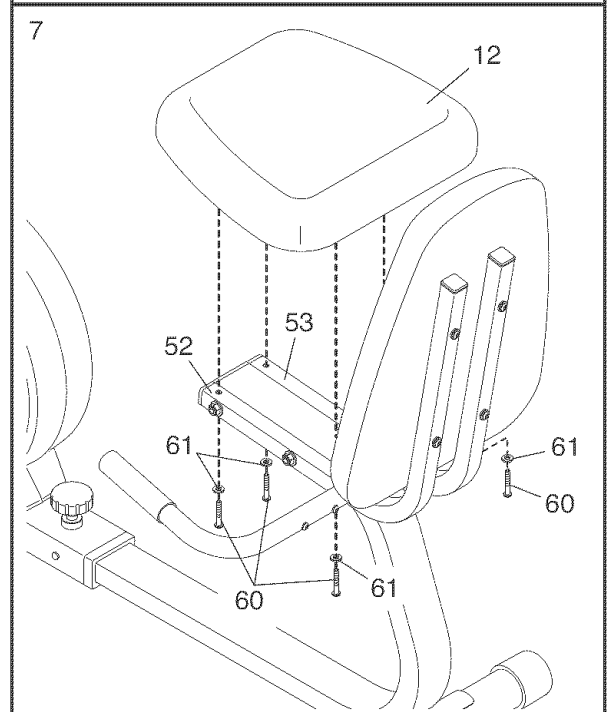

- The Console (16) requires three AA batteries (not included); alkaline batteries are recommended. Insert three batteries into the Console as shown in the inset drawing. **Make sure that the batteries are oriented as shown by the markings inside the Console.**

While another person holds the Console (16), attach the ground wire to the Handlebar (15) with an M4 x 12mm Screw (25). Next, insert the excess ground wire into the Console, and insert the console wire down through the indicated hole in the Handlebar.

Attach the Console (16) to the Handlebar (15) with four M4 x 16mm Screws (49). **Be careful to avoid pinching the ground wire and the console wire.**

- While another person holds the Handlebar (15) near the Upright (13), connect the console wire to the Extension Wire (36). Next, attach the Handlebar to the Upright with two M8 x 15mm Screws (34) and two M8 Split Washers (42). **Be careful to avoid pinching the console wire and the Extension Wire.**

- While another person holds the Upright (13) in the position shown, connect the Extension Wire (36) to the Reed Switch Wire (43). Next, connect the Resistance Cable (19) to the Lower Cable (45) in the following way:

- See drawing A. Pull up on the metal bracket on the Lower Cable (45), and insert the tip of the Resistance Cable (19) into the wire clip inside the metal bracket as shown.
- See drawing B. Firmly pull up the Resistance Cable (19) and slide it into the top of the metal bracket as shown.
- See drawing C. Using pliers, squeeze the prongs on the upper end of the metal bracket together.

Push the excess wire and cable down into the Frame (1), and slide the Upright (13) onto the Frame. **Be careful to avoid pinching the wires and cables.** Attach the Upright with two M8 x 15mm Screws (34) and two M8 Split Washers (42).

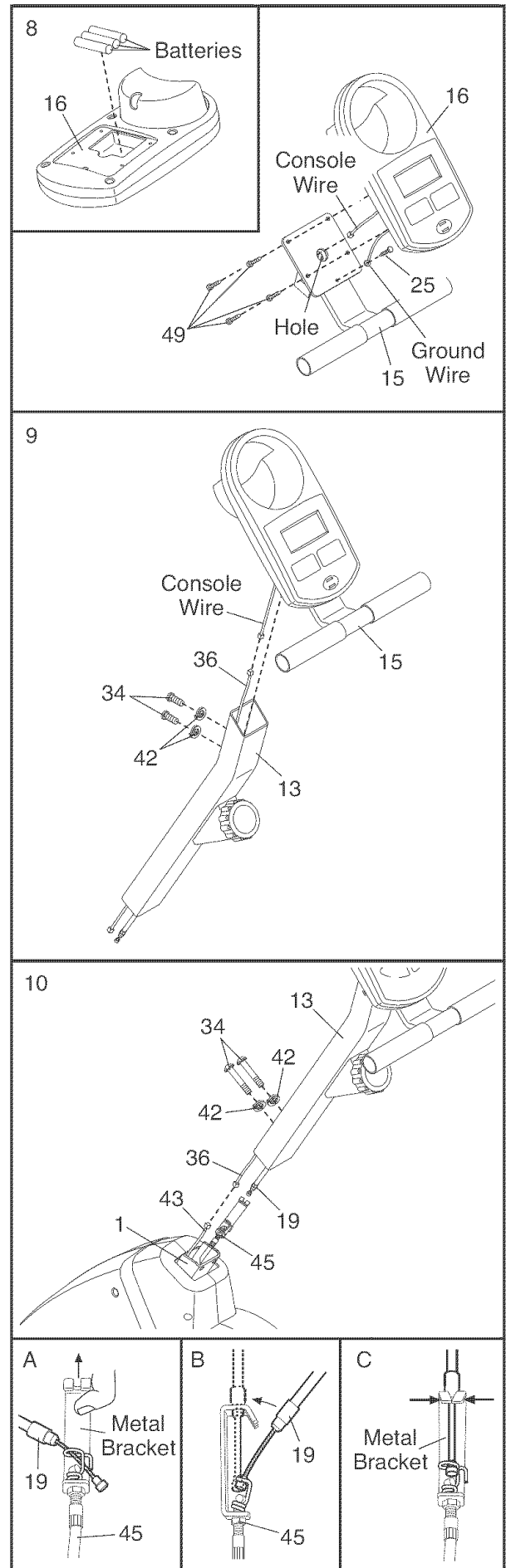

11. Identify the Left Pedal (24), which is marked with an "L." Using an adjustable wrench, firmly tighten the Left Pedal **counterclockwise** into the left arm of the Crank (21). Tighten the Right Pedal (not shown) **clockwise** into the right arm of the Crank. **Important: Tighten both Pedals as firmly as possible. After using the exercise cycle for one week, retighten the Pedals. For best performance, the Pedals must be kept tightened.**

Adjust the left Pedal Strap (58) to the desired position, and press the end of the Pedal Strap onto the tab on the Left Pedal (24). Adjust the right Pedal Strap (not shown) in the same way.

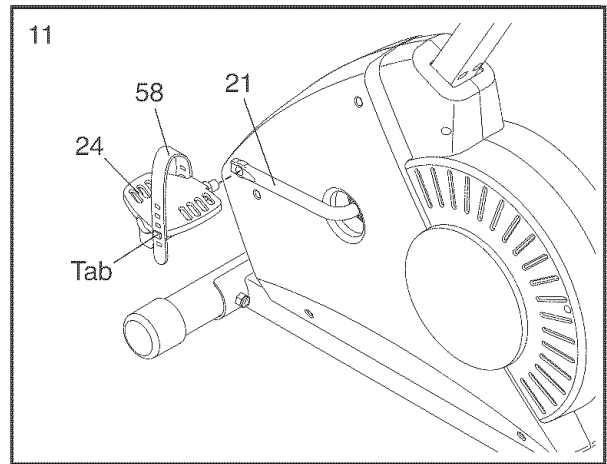

12. **Make sure that all parts are properly tightened before you use the exercise cycle.** Note: After assembly is completed, some extra parts may be left over. Place a mat beneath the exercise cycle to protect the floor.

HOW TO OPERATE THE EXERCISE CYCLE

HOW TO ADJUST THE SEAT FRAME

For effective exercise, the seat should be in the proper position. As you pedal, there should be a slight bend in your knees when the pedals are in the farthest forward position. To adjust the seat, loosen the adjustment knob, slide the seat frame forward or backward, and then retighten the adjustment knob.

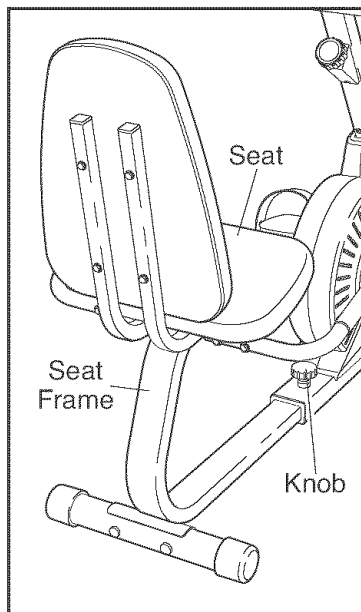

HOW TO ADJUST THE PEDALING RESISTANCE

To increase the resistance of the pedals, turn the resistance knob clockwise; to decrease the resistance, turn the knob counterclockwise. **Important: Stop turning the knob when turning becomes difficult, or the exercise cycle may become damaged.**

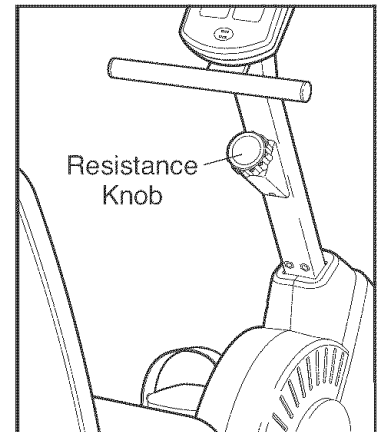

FEATURES OF THE CONSOLE

The console features a selection of modes that provide instant exercise feedback during your workouts. The modes are described below:

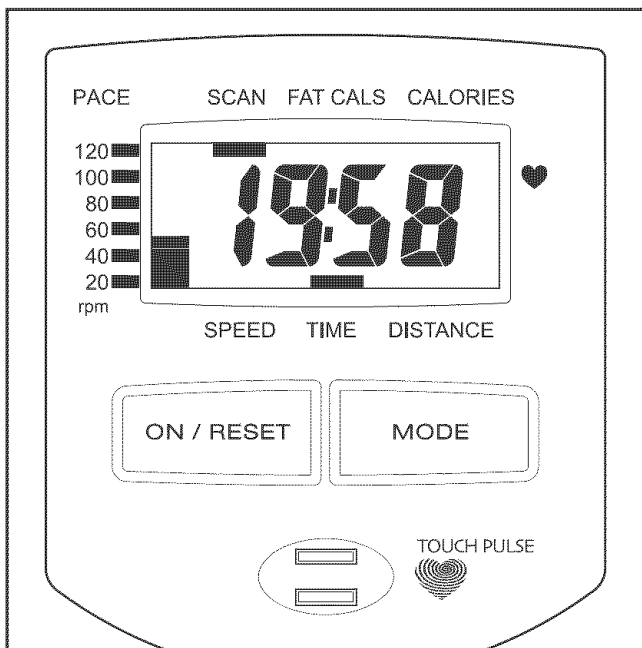

- **Speed**—This mode displays your pedaling speed, in miles per hour or kilometers per hour.
- **Time**—This mode displays the elapsed time. Note: If you stop pedaling for a few seconds, the time mode will pause.
- **Distance**—This mode displays the distance you have pedaled, in miles or kilometers.
- **Calories**—This mode displays the approximate number of calories you have burned.
- **Fat Calories**—This mode displays the approximate number of fat calories you have burned (see **FAT BURNING** on page 12).
- **Pulse**—This mode displays your heart rate when you use the pulse sensor.
- **Scan**—This mode displays the speed, time, distance, calories, fat calories, and pulse modes, for a few seconds each, in a repeating cycle. Note: The pulse mode will be displayed only while the pulse sensor is being used.
- **Pace**—The pace bar on the left side of the display shows your pedaling pace, in revolutions per minute (RPM). Note: The pace mode will always be displayed while you are pedaling.

HOW TO OPERATE THE CONSOLE

Make sure that there are batteries in the console (see **BATTERY REPLACEMENT** on page 11). If there is a sheet of clear plastic on the console, remove it.

Follow the steps below to operate the console.

1. To turn on the console, press the **ON/RESET** button or begin pedaling. All numbers in the display will appear briefly; the console will then be ready for use.
2. Select one of the modes:

Scan mode—

When the power is turned on, the scan mode will be selected automatically. One mode indicator will appear below the word **SCAN**, and a second mode indicator will show which mode is

currently displayed. Note: If you have selected a different mode, press the **MODE** button repeatedly to reselect the scan mode.

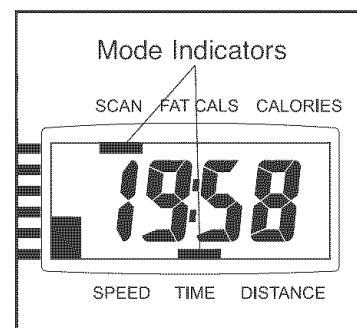

Speed, time, distance, calories, or fat calories mode—

To select one of these modes for continuous display, press the **MODE** button repeatedly. The mode indicators will show which mode is

selected. Make sure that there is not a mode indicator below the word **SCAN**.

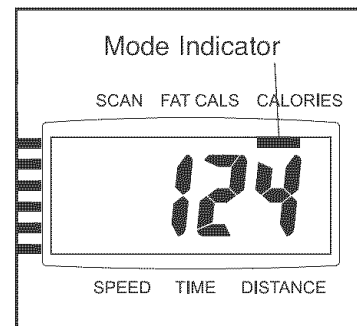

To reset the display, press the **ON/RESET** button.

Note: The console can display speed and distance in either miles or kilometers. To change the unit of measurement, press the ON/RESET button for about five seconds. The letters mph or km/h will appear in the display to show which unit of measurement is selected. When the batteries are replaced, it may be necessary to reselect the desired unit of measurement.

3. Measure your heart rate if desired.

To measure your heart rate, **stop pedaling** and place your thumb on the pulse sensor as shown. **Do not press too hard, or the circulation in your thumb will be restricted and your pulse will not be detected.** After a few seconds, the heart-shaped indicator in the display will flash steadily, two dashes will appear, and then your heart rate will be shown. Hold your thumb on the pulse sensor for about 15 seconds for the most accurate reading.

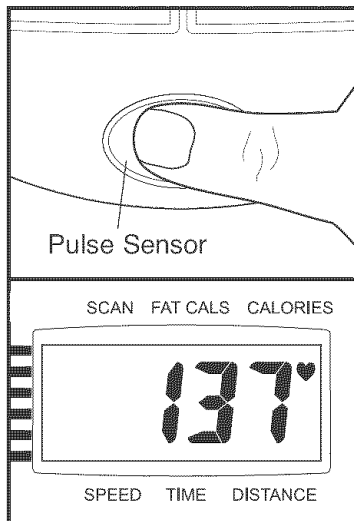

If the displayed heart rate appears to be too high or too low, or if your heart rate is not displayed, lift your thumb off the pulse sensor for a few seconds. Then, place your thumb on the pulse sensor as described above.

Make sure that you are applying the proper amount of pressure to the pulse sensor. Try the pulse sensor several times until you become familiar with it. Remember to sit still while measuring your heart rate.

▲ WARNING: The pulse sensor is not a medical device. Various factors may affect the accuracy of heart rate readings. The pulse sensor is intended only as an exercise aid in determining heart rate trends in general.

4. To turn off the console, simply wait for a few minutes. **The console has an “auto-off” feature. If the pedals are not moved and the console buttons are not pressed for a few minutes, the power will turn off automatically to save the batteries.**

MAINTENANCE AND TROUBLESHOOTING

Inspect and properly tighten all parts of the exercise cycle regularly. Replace any worn parts immediately.

To clean the exercise cycle, use a damp cloth and a small amount of liquid dish soap. **Important: To avoid damage to the console, keep liquids away from the console and keep the console out of direct sunlight.**

BATTERY REPLACEMENT

If the console display becomes dim, the batteries should be replaced; most console problems are the result of low batteries. To replace the batteries, first see assembly step 8 on page 7 and remove the console from the handlebar. Next, insert three batteries into the console. Reattach the console to the handlebar, being careful not to pinch the wires.

HOW TO ADJUST THE REED SWITCH

If the console does not display correct feedback, the reed switch should be adjusted. To adjust the reed switch, you must first remove the Left Side Shield (17). Using an adjustable wrench, turn the Left Pedal (24) clockwise and remove it. Next, remove the five M4 x 25mm Screws (41) and the M4 x 16mm Screw (49) from the Left Side Shield. Then, carefully remove the Left Side Shield.

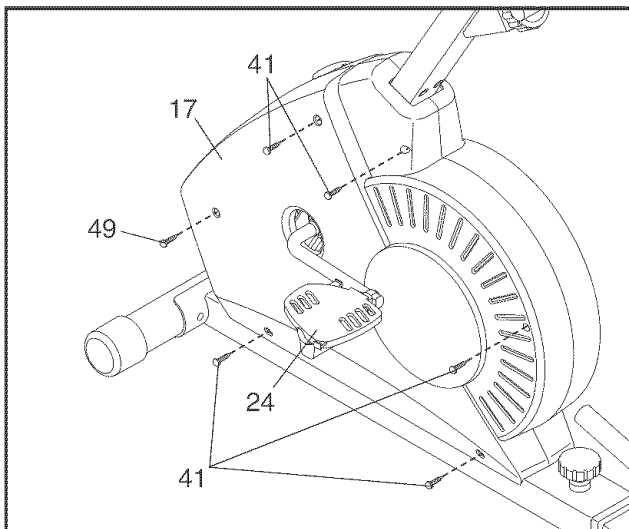

With the left side shield removed, locate the Reed Switch (43). Turn the Crank (21) until the Magnet (38) is aligned with the Reed Switch. Next, loosen, but do not remove, the indicated M4 x 16mm Screw (49). Slide the Reed Switch slightly closer to or away from the Magnet, and then retighten the Screw. Turn the Crank for a moment. Repeat until the console displays correct feedback. When the Reed Switch is correctly adjusted, reattach the left side shield and the left pedal.

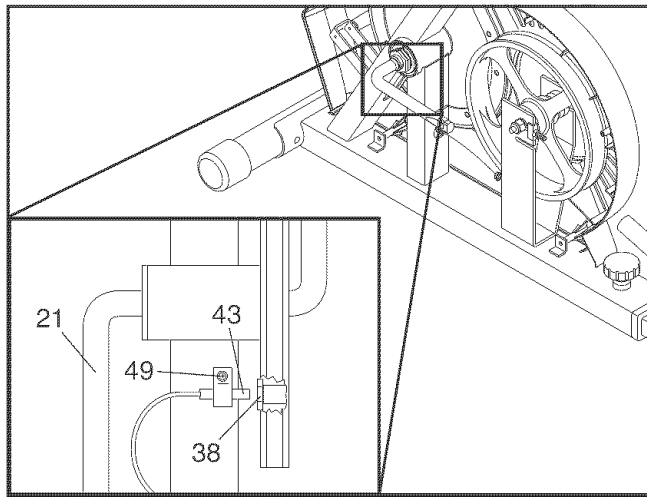

CONDITIONING GUIDELINES

The following guidelines will help you to plan your exercise program. Remember that proper nutrition and adequate rest are essential for successful results.

⚠ WARNING: Before beginning this or any exercise program, consult your physician. This is especially important for persons over the age of 35 or persons with pre-existing health problems.

The pulse sensor is not a medical device. Various factors may affect the accuracy of heart rate readings. The pulse sensor is intended only as an exercise aid in determining heart rate trends in general.

EXERCISE INTENSITY

Whether your goal is to burn fat or to strengthen your cardiovascular system, the key to achieving the desired results is to exercise with the proper intensity. The proper intensity level can be found by using your heart rate as a guide. The chart below shows recommended heart rates for fat burning, maximum fat burning, and cardiovascular (aerobic) exercise.

165	155	145	140	130	125	115	♥
145	138	130	125	118	110	103	♥
125	120	115	110	105	95	90	♥
<hr/>							
20	30	40	50	60	70	80	

To find the proper heart rate for you, first find your age at the bottom of the chart (ages are rounded off to the nearest ten years). Next, find the three numbers above your age. The three numbers are your “training zone.” The lowest number is the recommended heart rate for fat burning, the middle number is the recommended heart rate for maximum fat burning, and the highest number is the recommended heart rate for aerobic exercise.

Fat Burning

To burn fat effectively, you must exercise at a relatively low intensity level for a sustained period of time.

During the first few minutes of exercise, your body uses easily accessible *carbohydrate* calories for energy. Only after the first few minutes of exercise does your body begin to use stored *fat* calories for energy. If your goal is to burn fat, adjust the intensity of your exercise until your heart rate is near the lowest number in your training zone as you exercise.

For maximum fat burning, adjust the intensity of your exercise until your heart rate is near the middle of your training zone as you exercise.

Aerobic Exercise

If your goal is to strengthen your cardiovascular system, your exercise must be “aerobic.” Aerobic exercise is activity that requires large amounts of oxygen for prolonged periods of time. This increases the demand on the heart to pump blood to the muscles, and on the lungs to oxygenate the blood. For aerobic exercise, adjust the intensity of your exercise until your heart rate is near the highest number in your training zone.

WORKOUT GUIDELINES

Each workout should include the following three parts:

A warm-up, consisting of 5 to 10 minutes of stretching and light exercise. A proper warm-up increases your body temperature, heart rate, and circulation in preparation for exercise.

Training zone exercise, consisting of 20 to 30 minutes of exercising with your heart rate in your training zone. Note: During the first few weeks of your exercise program, do not keep your heart rate in your training zone for longer than 20 minutes.

A cool-down, with 5 to 10 minutes of stretching. This will increase the flexibility of your muscles and will help to prevent post-exercise problems.

EXERCISE FREQUENCY

To maintain or improve your condition, plan three workouts each week, with at least one day of rest between workouts. After a few months of regular exercise, you may complete up to five workouts each week, if desired. Remember, the key to success is make exercise a regular and enjoyable part of your everyday life.

SUGGESTED STRETCHES

The correct form for several basic stretches is shown at the right. Move slowly as you stretch—never bounce.

1. Toe Touch Stretch

Stand with your knees bent slightly and slowly bend forward from your hips. Allow your back and shoulders to relax as you reach down toward your toes as far as possible. Hold for 15 counts, then relax. Repeat 3 times. Stretches: Hamstrings, backs of knees, and back.

2. Hamstring Stretch

Sit with one leg extended. Bring the sole of the opposite foot toward you and rest it against the inner thigh of your extended leg. Reach toward your toes as far as possible. Hold for 15 counts, then relax. Repeat 3 times for each leg. Stretches: Hamstrings, lower back, and groin.

3. Calf/Achilles Stretch

With one leg in front of the other, reach forward and place your hands against a wall. Keep your back leg straight and your back foot flat on the floor. Bend your front leg, lean forward, and move your hips toward the wall. Hold for 15 counts, then relax. Repeat 3 times for each leg. To cause further stretching of the achilles tendons, bend your back leg as well. Stretches: Calves, achilles tendons, and ankles.

4. Quadriceps Stretch

With one hand against a wall for balance, reach back and grasp one foot with your other hand. Bring your heel as close to your buttocks as possible. Hold for 15 counts, then relax. Repeat 3 times for each leg. Stretches: Quadriceps and hip muscles.

5. Inner Thigh Stretch

Sit with the soles of your feet together and your knees outward. Pull your feet toward your groin as far as possible. Hold for 15 counts, then relax. Repeat 3 times. Stretches: Quadriceps and hip muscles.

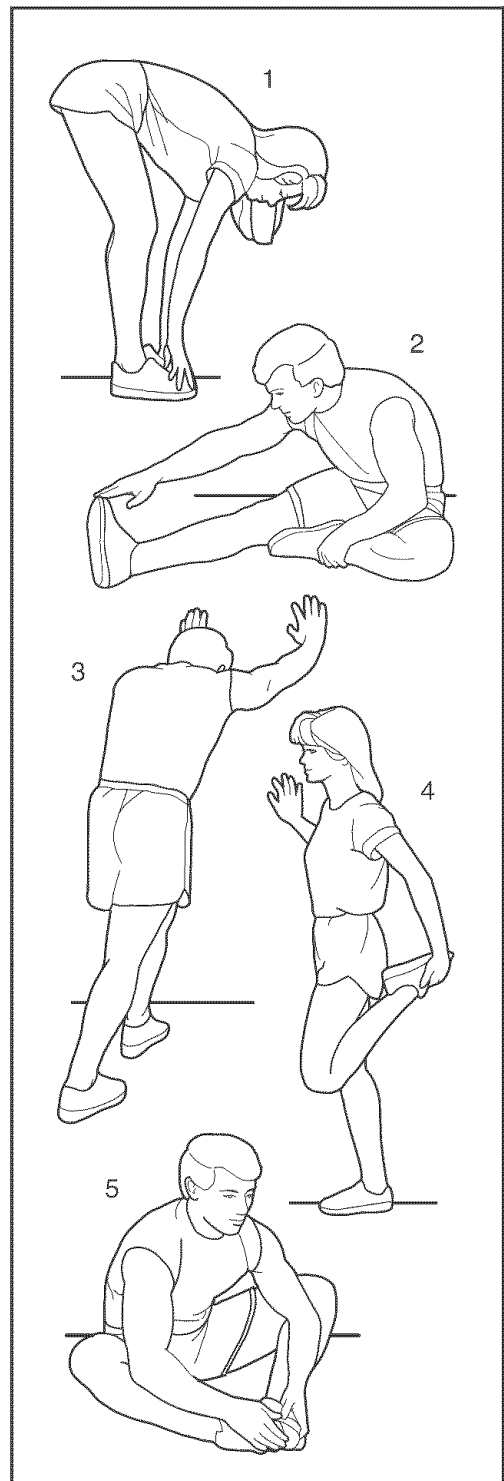

PART LIST—Model No. 831.21520.0

R0405A

Key No.	Qty.	Description	Key No.	Qty.	Description
1	1	Frame	37	1	Flywheel
2	2	Stabilizer	38	1	Magnet
3	1	Flange Nut	39	1	Flywheel Axle
4	4	Stabilizer Endcap	40	2	Bearing
5	1	Seat Frame	41	5	M4 x 25mm Screw
6	1	11.5mm Spacer	42	4	M8 Split Washer
7	4	Handlebar Endcap	43	1	Reed Switch/Wire
8	4	Foam Grip	44	1	Crank Bearing Set
9	1	Adjustment Knob	45	1	Lower Cable
10	4	M8 Nylon Locknut	46	1	Resistance Cable
11	1	C-magnet	47	1	Return Spring
12	1	Seat	48	1	Spring
13	1	Upright	49	8	M4 x 16mm Screw
14	4	M8 Washer	50	2	Seat Handle
15	1	Handlebar	51	1	Inner Frame Bushing
16	1	Console	52	1	Left Seat Bracket
17	1	Left Side Shield	53	1	Right Seat Bracket
18	1	Right Side Shield	54	1	Backrest
19	1	Resistance Control/Cable	55	4	Seat Bracket Endcap
20	1	Seat Frame Bushing	56	1	Seat Frame Endcap
21	1	Crank/Pulley	57	2	M8 x 115mm Bolt
22	1	Reed Switch Clamp	58	2	Pedal Strap
23	2	M10 Washer	59	1	13mm Spacer
24	1	Left Pedal	60	8	M6 x 30mm Screw
25	1	M4 x 12mm Screw	61	8	M6 Washer
26	1	Right Pedal	62	4	M6 x 26mm Bolt
27	1	Resistance Knob	63	4	M6 Nylon Locknut
28	2	U-bracket	64	2	M4 x 8mm Screw
29	1	Crank Nut	65	2	M4 x 5mm Screw
30	4	M10 x 65mm Carriage Bolt	66	2	Bumper
31	2	Eyebolt	67	2	M6 Zinc Nut
32	4	M6 Nut	68	1	M6 x 40mm Bolt
33	4	M10 Nylon Locknut	69	1	M8 x 61mm Shoulder Bolt
34	4	M8 x 15mm Screw	70	2	M4 x 16mm Flat Head Screw
35	1	Belt	#	1	User's Manual
36	1	Extension Wire	#	2	Allen Wrench

Note: # indicates a non-illustrated part. Specifications are subject to change without notice. **If a part is missing, call toll-free 1-866-699-3756.** See the back cover of this manual for information about ordering replacement parts.

EXPLODED DRAWING—Model No. 831.21520.0

R0405A

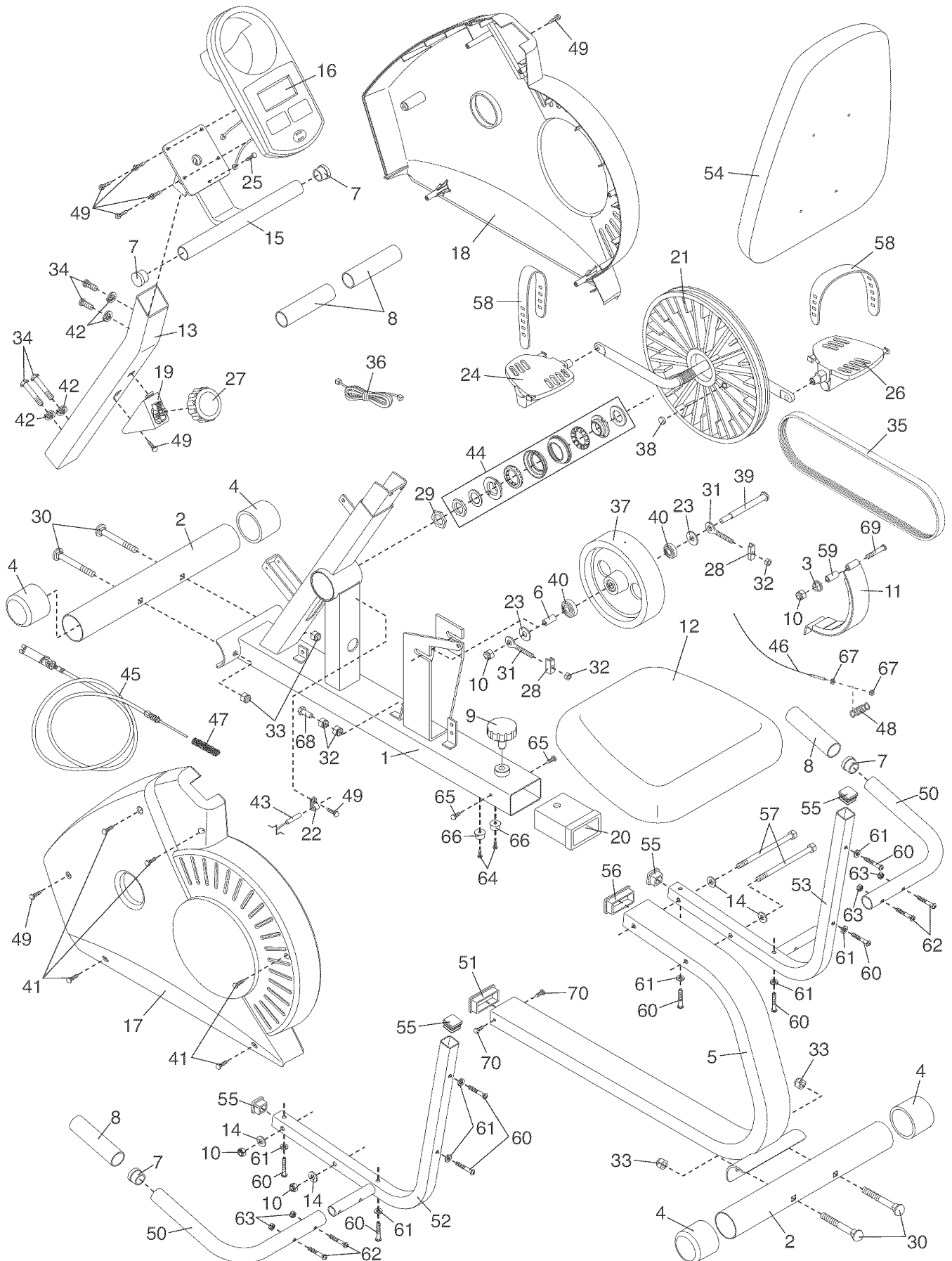

Get it fixed, at your home or ours!

Your Home

For repair – **in your home** – of **all** major brand appliances, lawn and garden equipment, or heating and cooling systems, **no matter who made it, no matter who sold it!**

For the replacement parts, accessories, and user's manuals that you need to do-it-yourself.

For Sears professional installation of home appliances and items like garage door openers and water heaters.

1-800-4-MY-HOME®

(1-800-469-4663)

www.sears.com

Anytime, day or night

(U.S.A. and Canada)

www.sears.ca

Our Home

For repair of carry-in products like vacuums, lawn equipment, and electronics, call or go on-line for the location of your nearest **Sears Parts and Repair Center.**

1-800-488-1222 Anytime, day or night (U.S.A. only)

www.sears.com

To purchase a protection agreement (U.S.A.) or maintenance agreement (Canada) on a product serviced by Sears:

1-800-827-6655 (U.S.A.)

1-800-361-6665 (Canada)

Para pedir servicio de reparación a domicilio, y para ordenar piezas:

1-888-SU-HOGARSM (1-888-784-6427)

SEARS

® Registered Trademark / ™ Trademark / ℠ Service Mark of Sears, Roebuck and Co.
® Marca Registrada / ™ Marca de Fábrica / ℠ Marca de Servicio de Sears, Roebuck and Co.

FULL 90 DAY WARRANTY

For 90 days from the date of purchase, if failure occurs due to defect in material or workmanship in this Sears Bike Exerciser, contact the nearest Sears Service Center throughout the United States and Sears will repair or replace the Bike Exerciser, free of charge.

This warranty does not apply when the Bike Exerciser is used commercially or for rental purposes.

This warranty gives you specific legal rights, and you may also have other rights which vary from state to state.

Sears, Roebuck and Co., Dept. 817WA, Hoffman Estates, IL 60179